

DRAFT

PLANNING FOR THE AIRPORT AND ITS ENVIRONS:  
THE SEA-TAC SUCCESS STORY

Prepared For  
The Federal Aviation Administration  
Office of Environmental Quality  
Washington, D.C.

Prepared By  
Peat, Marwick, Mitchell & Co.  
San Mateo, California

September 1977

DRAFT

## TABLE OF CONTENTS

I.	INTRODUCTION . . . . .	1
	<i>The Airport</i> . . . . .	2
	<i>The Sea-Tac Communities</i> . . . . .	8
	<i>The Project</i> . . . . .	11
II.	ANSWERS TO KEY QUESTIONS. . . . .	17
	<i>What Events or Issues Prompted the Port of Seattle, King County, and the FAA to Undertake the Sea-Tac Project?</i> . . . . .	17
	<i>What Was the Stated Purpose of the Sea-Tac Project?</i> . . . . .	22
	<i>Who Participated in the Project and How?</i> . . . . .	23
	Policy Advisory Committee (PAC) . . . . .	23
	Technical Advisory Committee (TAC). . . . .	24
	Study Team . . . . .	26
	<i>How Was the Community Involvement Process Handled?</i> . . . . .	26
	<i>How Was the Complex Issue of Noise Exposure Treated?</i> . . . . .	34
	<i>Why Were Some Noise Remedy Actions Taken Prior to Full Completion and Adoption of the Plan?</i> . . . . .	44
	<i>What Environmental Concerns Were Addressed During the Sea-Tac Project in Addition to Noise Exposure and Why?</i> . . . . .	46
	Water Quality and Drainage. . . . .	46
	Air Quality Analysis . . . . .	49
	Land Utilization. . . . .	52
	Community Attitudes Survey. . . . .	55
	<i>What Techniques Were Used to Evolve a Plan That Was Generally Acceptable to All Parties of Interest?</i> . . . . .	59
	Regular Meeting Format. . . . .	60
	Good Data Collection and Dissemination. . . . .	61
	Citizen Involvement . . . . .	63
	Forecast Coordination . . . . .	64
	Airline Inputs. . . . .	65
	Plan Alternatives Process . . . . .	67

## Table of Contents (cont.)

II.	ANSWERS TO KEY QUESTIONS (cont.)	
	<i>What Techniques Were Used to Evolve a Plan That Was Generally Acceptable to All Parties of Interest? (cont.)</i>	
	Improvement Program Terminology . . . . .	69
	Sector-By-Sector Public Meetings . . . . .	71
	A Single Airport and Communities Plan. . . . .	72
	<i>Who Was Designated to Fund and Carry Out Plan Recommendations? With What Resources? . . . . .</i>	73
	<i>Was the Sea-Tac Communities Plan Formally Adopted? By Whom? In What Form? . . . . .</i>	74
	<i>Has the Plan Been Followed During the Time That Has Passed Since Its Adoption? . . . . .</i>	76
	<i>Which Project Activities Proved to be Especially Useful? Which Ones Were Unproductive? What Else Should Have Been Done? . . . . .</i>	79
III.	CONCLUSION . . . . .	83
	<i>Why the Sea-Tac Project Was Successful . . . . .</i>	83
	<i>Is the Sea-Tac Approach Applicable Elsewhere? . . . . .</i>	84
	<i>Some Important Lessons . . . . .</i>	85
	REFERENCES . . . . .	R-1

## LIST OF FIGURES

1	Sea-Tac Communities Plan Study Area. . . . .	3
2	Sea-Tac International Airport . . . . .	5
3	Generalized Flow Diagram . . . . .	12
4	Sea-Tac Project Management . . . . .	14
5	ANE Values for 1973, 1978, 1983, and 1993. . . . .	38
6	ANE Grid Cells . . . . .	40
7	Sea-Tac Project: Plan Alternative Process . . . . .	70

## I. INTRODUCTION

*"The Sea-Tac Communities Plan is the first of its kind to be undertaken through the Planning Grant Program of the Federal Aviation Administration. It brought together the Port of Seattle, owner of the Sea-Tac Airport, and King County, the political entity responsible for land use in the area surrounding the airport, in a joint venture to determine how to best achieve compatibility between the airport and the surrounding communities. These two organizations, in developing the plan, encouraged the highest possible level of citizen participation through local meetings, an extensive information program, working groups, questionnaires and participation in both the technical and policy advisory committees. The citizen input as well as inputs from the airlines and other aviation interests, local businesses, and all levels of government, were utilized to develop imaginative and innovative solutions to the problems involved in achieving compatibility. Some of the solutions include acquisition, conversion and reinforcement of areas surrounding the airport to retain a viable community. Proposed noise solutions include acquisition, purchase assurance, easements, insulation of noise affected structures, development controls by public agencies, and property advisory services.*

*The study results and the cooperative effort that went into it can serve as a model for other communities nationwide that are beset with similar airport-community compatibility problems. For the Sea-Tac Communities the blueprint has been drawn. There now remains the opportunity to implement those plans."*

  
Robert O. Brown  
Chief, Airports Division  
NW Region, FAA

The preceding statement appeared as a foreword to the Sea-Tac Communities Plan report<sup>1</sup> completed in early 1975 as the chief end-product of an innovative two-year planning study co-sponsored by the Port of Seattle and King County, Washington. Funded in part by a grant from the Federal Aviation Administration (FAA), the study concentrated on the development of

a coordinated master plan for Sea-Tac International Airport and its environs, a 44-square mile area adjoining Puget Sound between the cities of Seattle and Tacoma (see Figure 1).

As indicated by Mr. Brown, the Sea-Tac Project can well serve as a model for other locales that are objectively trying to achieve maximum compatibility between a busy airport and the surrounding community. In recognition of this point of view, the FAA has determined that a detailed evaluation of the Project could be of value to many interests. Such an evaluation is contained in this document, together with a summary version<sup>2</sup> of the original Sea-Tac Communities Plan.

General descriptions of the Airport, its environs area, and the planning project are set forth in Part One of the report. Part Two provides answers to some 12 key questions that may be and often are posed relative to the study. Part Three concludes with observations as to why the Sea-Tac Project was successful, its application in other parts of the United States, and some important lessons that were learned as a result of this pioneering effort.

#### *THE AIRPORT*

Owned and operated by the Port of Seattle, the Sea-Tac International Airport occupies a 2,200-acre site located in Southwestern King County approximately 15 miles to the south of Downtown Seattle.

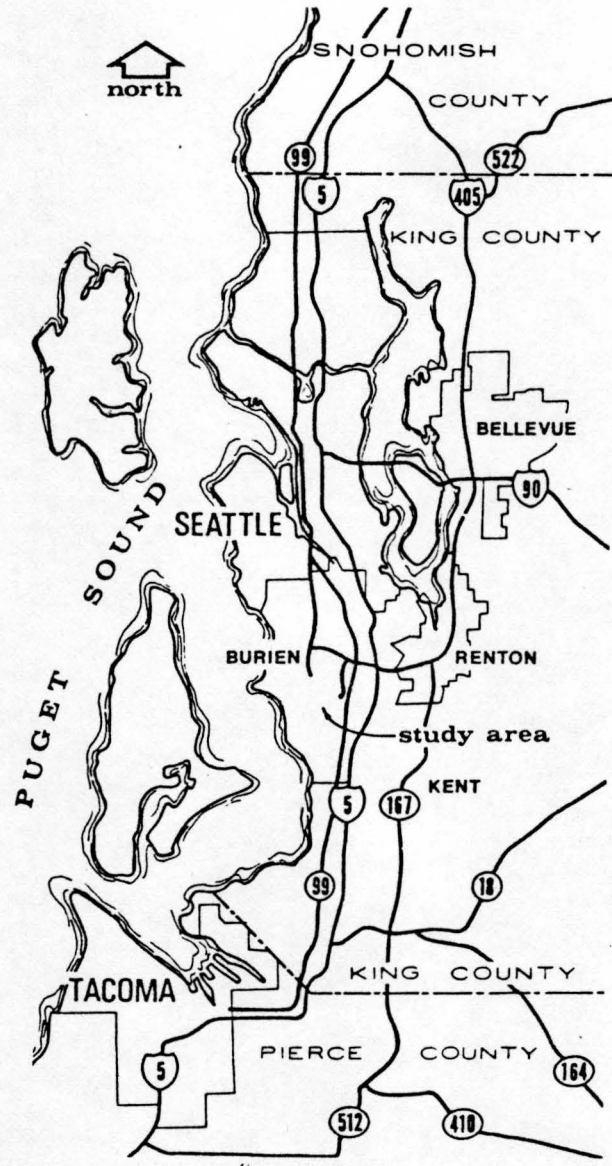

figure 1. SEA-TAC COMMUNITIES PLAN STUDY AREA

As one of two dozen or so large hub airports in the United States, the Sea-Tac facility handled nearly 7 million passengers and 115,000 air carrier aircraft operations in 1976. It is currently served by ten certificated air carriers and two foreign flag carriers. The U.S. carriers include Alaska Airlines, Braniff International, Continental Air Lines, Eastern Air Lines, Flying Tiger Line, Hughes Air West, Northwest Orient Airline, Pan American World Airways, United Air Lines, and Western Air Lines. Pacific Western Airlines and the Scandinavian Airline System are the foreign air carriers. United Air Lines is the dominant carrier at Sea-Tac as it enplanes nearly one-half of all passengers and accounts for about 40% of all air carrier aircraft departures.

The airfield system at Sea-Tac International Airport (see Figure 2) features two close parallel air carrier runways, one of which is 11,900 feet in length and has a concrete surface (16L-34R), while the other is 9,425 feet long and has an asphalt surface (16R-34L). The airfield also includes a general aviation runway (17-35), as well as appropriate taxiways, lighting, all-weather marking, and advanced navigation aids. Due in part to the presence of nearby Boeing Field, there is only one fixed base operator (FBO) and no based general aviation aircraft at the Sea-Tac facility.

An expansion and improvement program completed in 1973 resulted in a terminal complex at Sea-Tac that is capable of handling



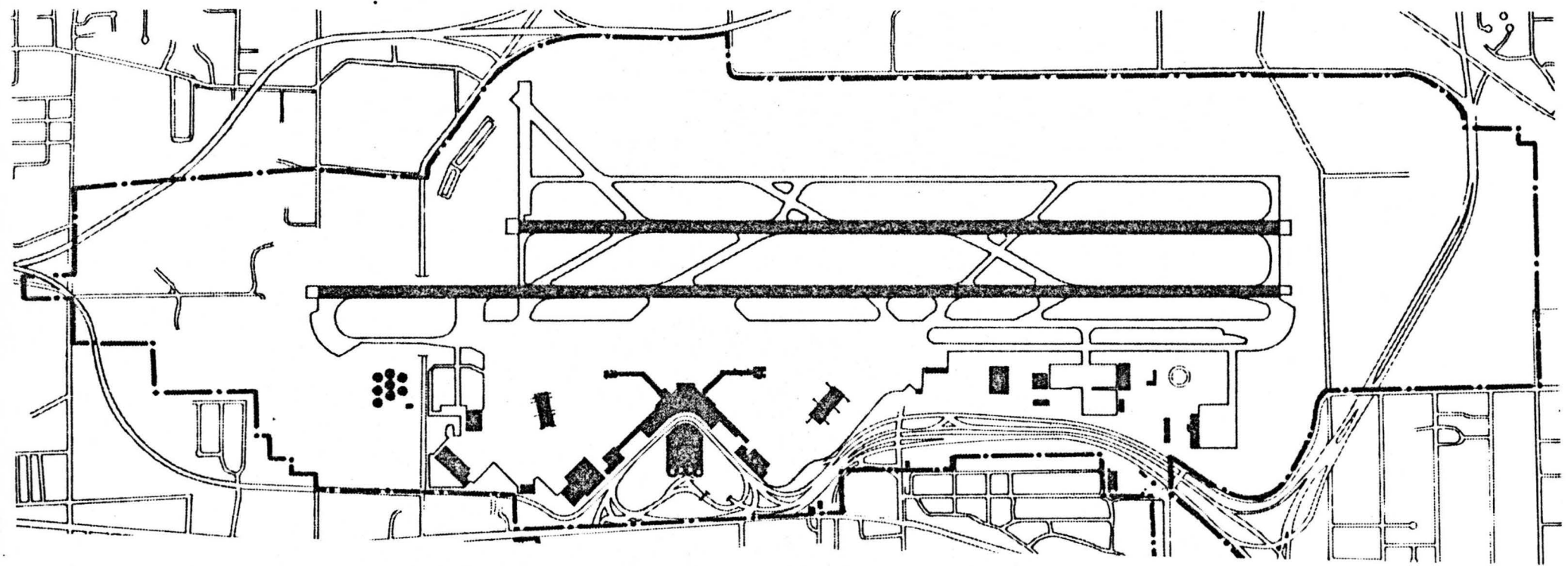

  
north

figure 2. SEA-TAC INTERNATIONAL AIRPORT

up to 20 million passengers per year. Consisting of two satellite units which are connected to the main terminal by a modern underground transit system, the overall complex includes gate positions for up to 65 aircraft, 35 of which are currently in operation. The South Satellite has been designed for and is operated solely as an international arrival and departure terminal.

A seven-story parking garage adjacent to the terminal contains 4,150 public parking spaces (one level of the garage is presently utilized for rental car parking and servicing only). In addition, a remote surface lot is provided for employee use. This lot can accommodate more than 1,000 vehicles.

Ground access to Sea-Tac is generally excellent due to the nearness of Interstate Highway 5 which is connected to the Airport by means of State Highway 518 on the north and S. 188th Street on the south. As might be expected of the largest airport in the Pacific Northwest, the Sea-Tac installation has extensive air cargo handling accommodations as well as fire station, fuel storage, waste disposal, utility system, and similar airport support facilities.

Economic implications of Sea-Tac International Airport on the community and region were most recently documented in a 1974 report<sup>3</sup> prepared by the Port of Seattle Planning and Research

Department. Highlights of that report included the following items of interest:

- Book value of the Airport increased from \$5,000,000 in 1942 to \$204,000,000 in 1973.
- The original 906-acre Airport site was purchased at an average cost of \$702 per acre (unimproved) in 1942. When additional land was acquired in 1954, the price was \$3,600 per acre. By 1962, the cost of improved land purchased adjacent to the Airport had risen to \$15,600. In 1973, similar improved land had climbed to \$98,000 an acre!
- More than 15,200 jobs accounting for a gross annual payroll of over \$160,000,000 and \$390,000,000 in yearly business activity in King County are related (as of 1973-74) to the commercial traffic of Sea-Tac International Airport.
- Some 38,000 King County residents relied directly or indirectly on the Airport for their livelihood in 1973. Based on activity forecasts available at that time, this figure may be as high as 64,000 persons by 1990.

As indicated by the foregoing data and information, the Sea-Tac Airport is a major public installation of considerable importance to King County, the Puget Sound Region, and the State of Washington. Because of its very size, presence, and operation, the Airport most directly affects--and is affected by--a host of neighboring communities. These communities are described in the next section.

*THE SEA-TAC COMMUNITIES*

Based upon the most recent population estimates, that part of King County which has been termed the Sea-Tac Communities area now contains some 140,000 residents. Encompassing more than 44 square miles of territory, this area is bounded by the Seattle corporate limits on the north, the Green River Valley/ Interstate Highway 5 corridor on the east, S. 288th Street on the south, and Puget Sound on the west.

In 1940, shortly before the Civil Aeronautics Administration (now the FAA) selected an airport site near swampy Bow Lake, the above area had a total population of just 15,000. By 1950, due primarily to World War II and the related growth of defense activities and industries--especially the Boeing Airplane Company--some 45,000 persons lived in the area. The population more than doubled again between 1950 and 1960.

Although originally settled in a pattern of small farms and logging villages, the Sea-Tac Communities locale is essentially an urban residential area at the present time. It includes several small cities such as Des Moines and Normandy Park, as well as portions of the cities of Kent and Tukwila. The largest concentration of homes and businesses occurs at Burein, an unincorporated community situated just to the northwest of Sea-Tac International Airport.

Ranging in elevation from 350 to 450 feet with very abrupt slopes falling off to the east, northeast, and west, the Sea-Tac Communities area may be topographically characterized as a gently rolling plateau. Several small creeks on the plateau's east side, together with the larger Des Moines, Miller, and Salmon Creek drainage basins on the west side, have created numerous rugged wooded ravines as they course down from the uplands to either Puget Sound or the industrialized Green River Valley.

As stated in the Summary Plan report, much of the single-family home development now in existence within the Sea-Tac Communities took place during and as part of the area's most rapid growth period, e.g., between 1940 and the early 1960s. In recent years, more duplex and apartment units have been constructed than detached single-family homes, a trend projected to continue.

Also of interest is the fact that high-rise office buildings are beginning to appear along Highway 99 near the entrance to the Sea-Tac terminal complex. Indeed, an extensive strip of commercial uses--motels, restaurants, car rental agencies, service stations, etc.--has grown up on both sides of Highway 99 in direct response to the Airport's development over the years.

Other uses of note within the overall area include a community college, several public parks and golf courses, some low income public housing projects, and a variety of "rural" activities

such as horticultural nurseries, commercial truck gardens, and small pastures for horses and cattle.

As will be referred to later in this report, certain characteristics of the resident population are of importance. Apart from the still-suburbanizing area south of the Airport, the environs population is aging and will continue to do so, according to the King County planners who participated in the Project. At present, only 9% of the total population is under 5 years of age.

Elderly people make up a high percentage of the residents located directly to the east and northeast of Sea-Tac due to the existence in these areas of modest, long-established homes where older persons of limited means can still afford to live. A number of the elderly also live in trailer parks, retirement homes, and specialized housing projects situated within the Airport vicinity.

According to the County planners, the Sea-Tac Communities area is generally occupied by a population that is (a) predominantly white; (b) somewhat more mobile and less educated than the corresponding averages for King County as a whole; and (c) considered to be middle income for the most part. In addition, the residents of this area tend to be concerned about and interested in the development of their particular neighborhoods.

This latter factor was largely responsible for the successful citizen involvement program that was mounted and sustained as part of the Sea-Tac Project.

#### *THE PROJECT*

Organized in general conformity with FAA guidelines for the development of an airport master plan,<sup>4</sup> the Sea-Tac Communities Plan Project was initiated in March of 1973 and fully completed some 24 months later. The Project was sponsored and/or funded by the following governmental entities:

- Port of Seattle, owner and operator of the Sea-Tac International Airport. The Port's multi-faceted affairs are directed by a five-member commission elected by the citizens of King County.
- King County, the general purpose government most responsible for overall planning, land use regulation, and the provision of public facilities within the Airport environs area. County functions are managed by an elected County Executive and seven-member County Council.
- Federal Aviation Administration, an agency of the U.S. Department of Transportation. FAA activities in the states of Washington, Oregon, and Idaho are supervised by the Northwest Regional Office located in Seattle.

Two-thirds (\$427,978) of the approved \$642,000 project budget was provided by the FAA under terms and provisions of the Planning Grant Program (PGP) authorized by the U.S. Congress as part of the Airport & Airway Development Act of 1970. The remaining one-third local share was provided by the Port and County in the form of designated staff time and services.

Although the agreed-upon Project Work Program<sup>5</sup> did track the required PGP format, the focus and direction of this Study was significantly different than previous efforts by other airport sponsors. Instead of concentrating solely on the development of an airport master plan, the Sea-Tac Project emphasized (1) extensive measurement and analysis of key environmental conditions such as community attitudes, noise exposure, air quality, water quality, and solid waste management; (2) off-Airport land use planning and regulation; (3) meaningful citizen involvement in the planning process; and (4) the evolution of a composite Airport/Environs master plan.

As depicted by Figure 3, the planning process followed to produce the Sea-Tac Communities Plan involved five major forms of activity: airport planning; vicinity or community planning; specialized environmental studies; community involvement; and project coordination. The Plan's evolution was based on a deliberate blending of airport and community plans that were dependent to a large extent upon environmental conditions. Community involvement and coordination components were on-going throughout all phases of the study.

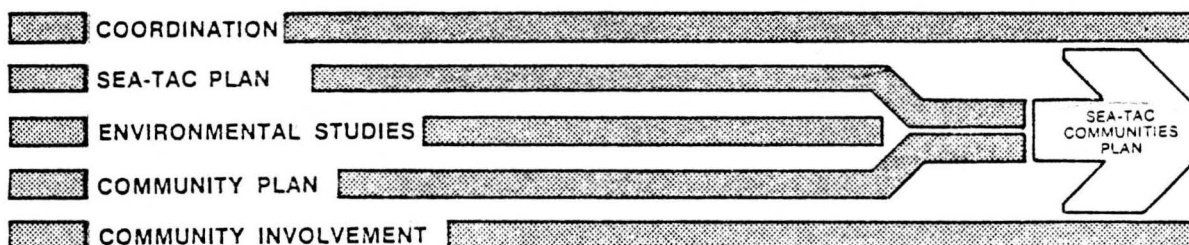

figure 3. GENERALIZED FLOW DIAGRAM



The format used to manage the Sea-Tac Project is outlined on Figure 4. Technical and/or supportive aspects of all activities were handled by a Study Team composed of Port and County planning, engineering, and research personnel, together with several specialized consultants. Study Team functions were supervised by the overall Project Director (from the Port of Seattle), who was aided by a Technical Advisory Committee and individual Project Managers from the Port Planning Staff, County Land Use Management Staff, and Peat, Marwick, Mitchell & Co. The latter firm served as General Coordinating Consultant for the Sea-Tac Project.

The Technical Advisory Committee (or TAC) consisted of some 15-20 members representative of (a) various local, regional, state, and federal agencies; (b) local community organizations; and (c) aviation interests. As anticipated by the Project Study Design, the flow of input between the Project Director/Study Team and this group was in both directions. Advice and information about pertinent agency plans and programs was provided by TAC members who, in turn, received program reports, data, and information about contemplated programs or plans being developed by the Study Team. The aviation industry was strongly represented on the Committee in order to provide advice on such key matters as the formulation of valid technical criteria, forecasts of future airline passenger and aircraft operations

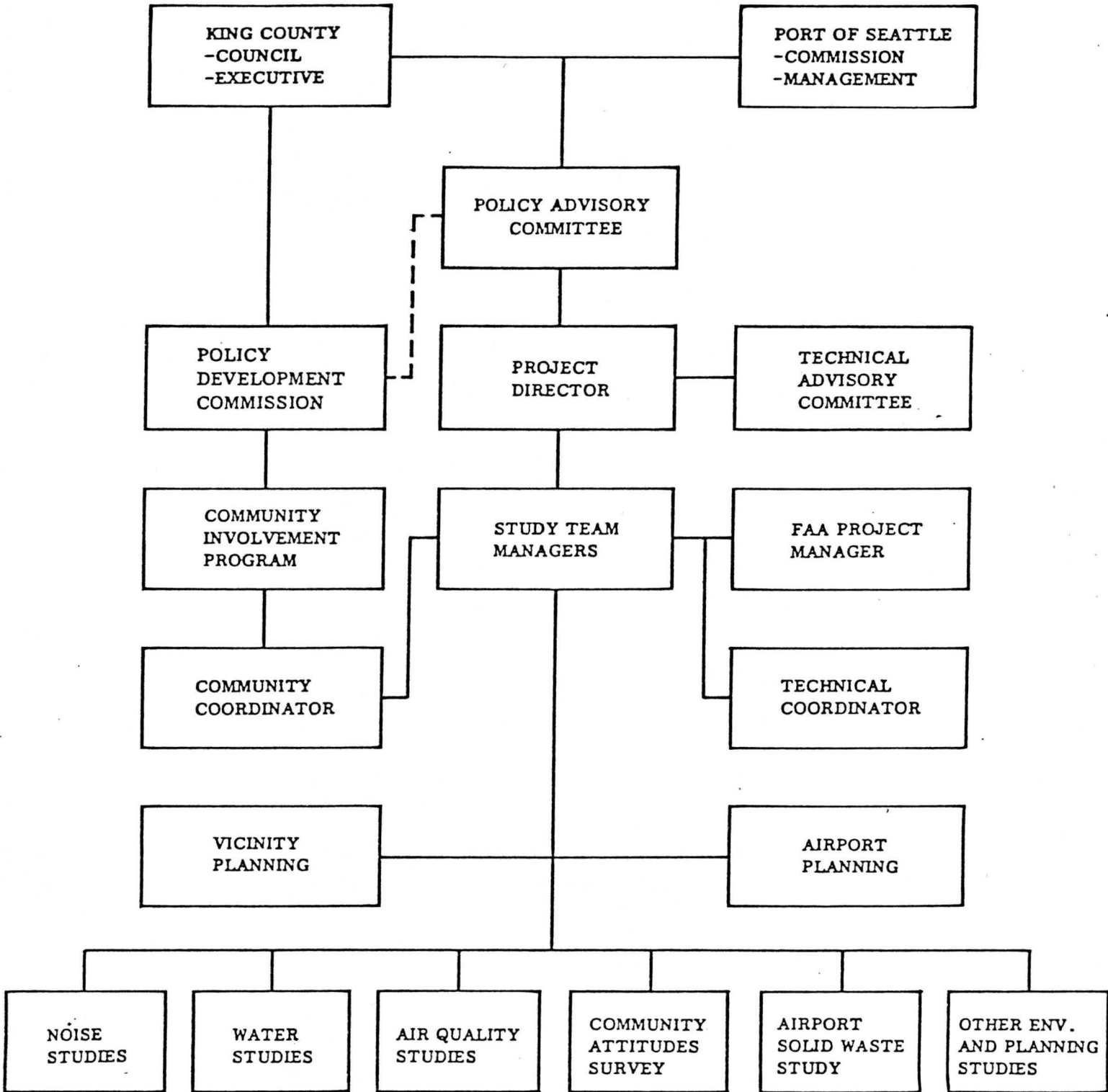

figure 4. SEA-TAC PROJECT MANAGEMENT

at the Airport, and anticipated technological improvements with respect to aircraft noise, size and type of aircraft, and flight procedures.

All proposals, conclusions, and recommendations of the Study Team were also reviewed and commented on by a Policy Advisory Committee (or PAC). This Committee included several citizen members, along with key representatives of those agencies or organizations responsible for the bulk of Plan implementation.

Due to the day-to-day relationships they had with their respective decision-making groups, the PAC representatives were able to provide direct and timely responses to the numerous courses of action (near- and long-term) that were proposed by the Study Team. It should also be noted that the Policy Advisory Committee was loosely structured and very flexible as to its make-up. Members were added as additional organizations or agencies having a relevant role to play in Plan implementation were identified during the Study.

As noted previously, an extensive and productive citizen involvement program was carried out as part of the Sea-Tac Communities Plan Project. The program was under the general direction of King County's Policy Development Commission (PDC), a broad-based organization of citizens who serve in an advisory capacity to the County Council. The PDC, through its Land Use Committee, agreed upon the following objectives as operational guidelines for this program:

- Promote community interest in the Sea-Tac Study.
- Include citizen participants in the day-to-day operations of the Community Involvement Program.
- Maximize public understanding of technical studies.
- Stimulate and respond to community concerns and ideas.
- Promote community expression of views on Study activities and plan alternatives.

More details of the program are included in Part II of this report.

## II. ANSWERS TO KEY QUESTIONS

The Sea-Tac Communities Plan Project was a most comprehensive and ambitious undertaking. As has been noted, it represented the first real attempt to determine how best to achieve maximum compatibility between a major air carrier airport and its neighbors. In general, the mission was successfully accomplished.

As a consequence of this success, numerous airport sponsors, community planners, state and federal agency representatives, and others have requested more information about the Sea-Tac study, especially as to how it worked and why. In response to such requests, this part of the report is designed to provide answers to a number of key questions concerning the Project. A question and answer format has been utilized for the benefit of those users who only need or want information about a specific point of interest, as well as for those who wish to gain an understanding of the overall effort.

### *WHAT EVENTS OR ISSUES PROMPTED THE PORT OF SEATTLE, KING COUNTY, AND THE FAA TO UNDERTAKE THE SEA-TAC PROJECT?*

Over the first fifteen years of its existence, the public facility now known as Sea-Tac International Airport enjoyed a reasonably harmonious relationship with the surrounding, primarily rural environment. However, the initiation of jet air carrier service in 1957 signaled the beginning of a difficult

period of discontent and even hostility between the Airport and its rapidly suburbanizing neighborhood.

Noise litigation became a "way of life" for the Port of Seattle and numerous property owners in the Airport vicinity who were (or claimed to be) bothered by excessive aircraft-generated noise. Between 1965 and 1970, approximately 525 parcels of land were involved in litigation relative to the one air carrier runway then in existence. Completion of a new parallel runway in 1970-71 stimulated numerous additional lawsuits.

As one of the first airport sponsors in the country to be sued over noise, the Port had little or no guidance from elsewhere as to how to deal with the problem. In the absence of such guidance, what may be termed a "let them sue" approach was essentially followed by the Port during the period from 1957 to 1972. Under this approach, every noise lawsuit was contested in court. If the Port won, no further action would be taken. However, if the property owner(s) was awarded damages, the Court would typically decree that the Port receive an avigation easement in return for the payment of such damages.

Prior to initiation of the Sea-Tac Project in 1973, the Port of Seattle had paid out some \$1.2 million as a result of all noise litigation to that date. While this sum was indeed substantial, it was viewed by Port management as being far less costly than other possible courses of action, such as outright

acquisition of noise-impacted property or moving the Airport to another location. Inasmuch as the Airport had always been run as an economic entity on a least cost basis, the unofficial "let them sue" policy appeared to have been prudent and effective after a decade or so of application.

With regard to the possibility of moving the Airport to a better location, a special study completed in late 1969<sup>6</sup> indicated that a new air carrier facility at any operationally feasible site within the Puget Sound Region would initially cost upwards of \$250 million (not counting required new ground access), and also encounter substantial environmental resistance. Coming at a time when the local economy was at a low ebb due to massive reductions in the aerospace work force, and while the Port was in the middle of a \$175 million expansion program at the Sea-Tac installation, the report inadvertently scuttled any further talk of a new airport for the Seattle area.

In the spring of 1971, a committee of residents who lived within what the FAA had previously delineated as a "zone three" noise impact area (based on the Composite Noise Rating or CNR system) formed to recommend that new policies be adopted by the Port of Seattle. As indicated in a League of Women Voters document "Sea-Tac & Its Neighbors,"<sup>7</sup> this Zone Three Committee wanted the Port to:

1. Recognize that a defined area around the Airport was not suitable for residential use.

2. Recognize that payment of damages to the individual does not solve the noise and pollution problem for the Port or the individuals.
3. Undertake cost surveys for the purchase of all properties in a defined area most adversely affected by the noise and pollution.
4. Explore the possibility of obtaining technical and financial assistance from federal agencies for establishment of a buffer zone against noise and pollution.

In support of their position, the Zone Three Committee circulated a petition that was signed by over 7,000 persons of voting age, representing some 2,700 households, the majority of which fell within the then designated CNR zone three area.

A variety of circumstances and conditions prevalent at the time helped to fuel this citizen-sparked fire, such as:

- The local Federal Housing Administration (FHA) office had refused to insure new home construction in zone three since 1969, and noise was considered to be a factor by FHA in all other appraisals within the impact area. Such a policy was in response to noise guidelines<sup>8</sup> promulgated by FHA's parent agency, the U.S. Department of Housing and Urban Development (or HUD).
- Recent property revaluations in the area had resulted in tax increases for most homeowners, some of whom were also having to cope with additional assessments for new sewer installations.
- Due to the long history of aircraft plant and testing operations at nearby Boeing Field, and also to the emergence of OSHA (Occupational Safety & Health Administration) activities, there was a community-wide concern about the health/safety of those who lived in close



proximity to the Sea-Tac Airport. Among other things, such concerns had been reflected in some of the early court settlements that involved the establishment of avigation easements over certain properties.

- Between 1968 and 1971, the local economy was in bad shape due primarily to a loss of some 70,000 aerospace jobs over this three-year period. At one point, the unemployment rate reached 15% and was the highest of any metropolitan area in the United States.
- The foregoing recession not only created personal economic difficulties for many who lived near the Airport, it also produced a sluggish local housing market which resulted in even further anxieties. At a time when taxes were up, the market was down and showed little evidence of improvement--even in areas with virtually no impact from aircraft noise.

In its role as operator of the largest and most visible public facility in the southwestern part of King County, the Port of Seattle was a ready-made "target" for vocal property owners with tax, employment, house sale, or noise problems. These citizen complaints, as well as Zone Three Committee activities, naturally received a good deal of news media attention in the form of newspaper articles, television programs, radio talk shows, and the like. As a consequence, the Port's elected and administrative officials became painfully aware of the fact that while the "let them sue" approach had been "cost effective," it had also helped to spawn a very negative attitude toward the Airport and its owners.

In 1972, top Port management decided to objectively deal with the problem by means of a cooperative, plan-oriented approach. Fortunately, King County was also willing, able, and ready to participate at that time in a detailed plan effort on behalf of the Highline/Sea-Tac area. In addition, a new policy which permitted the Seattle FAA office to commit funds for off-airport land use planning had just been adopted by the agency's central headquarters in Washington, D.C. All of these factors, as well as others, combined to make the Sea-Tac Project one "whose time had come."

*WHAT WAS THE STATED PURPOSE OF THE SEA-TAC PROJECT?*

The Sea-Tac Communities Plan Project was organized, funded, and carried out for the express purpose of determining how Sea-Tac International Airport and the surrounding area could best achieve maximum compatibility. Stated in another way, the overall goal of this undertaking was to "make the Airport and the Community better neighbors."

Four specific objectives were articulated in furtherance of the above goal:

- To develop a comprehensive Airport and Communities Master Plan that will improve relationships between Sea-Tac International Airport and its Environs.
- To incorporate detailed environmental inventories into the study such that all relevant environmental factors are assured full and careful consideration.

- To proceed in a manner which (a) fully addresses the advantages and disadvantages associated with each and every viable plan alternative, and (b) provides for adequate public involvement in all such deliberations.
- To develop final recommendations that are soundly based on all pertinent technical, economic, social, environmental, and financial factors, and which provide for the adoption of specific implementation policies by the Port of Seattle, King County, and other appropriate agencies, including the Federal Aviation Administration.

#### *WHO PARTICIPATED IN THE PROJECT AND HOW?*

A host of individuals and organizations took part in the evolution of a workable Sea-Tac Communities Plan. As outlined by Figure 4, the Port of Seattle Commission and the King County Executive and Council made all final decisions (including adoption of the Plan) in accordance with their respective functions as elected officials. Others who made direct contributions to the Project are generally described in the next several paragraphs.

#### Policy Advisory Committee (PAC)

This top echelon committee was charged with the following responsibilities:

- a. Monitor study progress in keeping with the grant agreement executed by and between the FAA and the co-sponsors (Port and County).

- b. Provide appropriate on-going liaison between the Study Team, the Project co-sponsors (Port and County), the FAA, other governmental agencies, and community interest groups.
- c. Function as a review forum or sounding board for various findings, proposals, alternatives and/or recommendations developed by the Study Team.
- d. Ensure continuous communication with policymakers to minimize possible conflicts and maximize implementable solutions.

The Director of Aviation for the Port of Seattle served as Chairman of the PAC group. King County's Director of Community and Environmental Development was the Vice-Chairman. Other members included:

Deputy General Manager-Port of Seattle  
 Director of Land Use Management Division-King County  
 City Manager-Des Moines, Washington  
 President-Highline Community College  
 Regional Director of Governmental Affairs-United Air Lines  
 Citizen Representative-Zone Three Committee  
 Citizen Representative-Highline Community Council  
 Citizen Representative-King County Policy Development Commission

#### Technical Advisory Committee (TAC)

An extensive Technical Advisory Committee was established at the outset of the Sea-Tac Project in order to:

- a. Serve as a vehicle for exchanging technical information and viewpoints between committee members and staff of the Port of Seattle, King County, and consultants.

- b. Provide regular contact and liaison between individual groups represented, and insure that all aspects of the Study were properly coordinated with relevant local, regional, state, or federal planning activities.
- c. Function as a review forum or "sounding board" for various findings, proposals, alternatives and/or planned recommendations that would be produced by the Study Team during the course of the Project.

The TAC was chaired by the Director of Planning and Research for the Port of Seattle (who also served as overall Project Director). Organizational representatives on this Committee were as follows:

Port of Seattle-Aviation, Engineering, Legal,  
 Planning and Research, Real Estate, and Public  
 Relations Departments  
 King County-Community and Environmental Develop-  
 ment, Park, and Public Works Departments  
 Federal Aviation Administration (FAA)  
 Federal Housing Administration (FHA)  
 Environmental Protection Agency (EPA)  
 Washington State Aeronautics Commission  
 Washington State Highway Department  
 University of Washington-Division of Community  
 Development and Department of Urban Planning  
 Puget Sound Governmental Conference  
 METRO (Metropolitan Transit and Sewer Authority)  
 City of Normandy Park, Washington  
 City of Seattle, Washington  
 City of Tukwila, Washington  
 Federal Way School District  
 Highline Public Schools  
 Various Special Districts (Fire, Water, Sewer)  
 Airline Pilots Association  
 Boeing Aircraft Company  
 Pacific Northwest Bell Company  
 United Air Lines

### Study Team

The approved Sea-Tac Project Work Program was essentially carried out by a Study Team that was led by the respective Project Managers for Peat, Marwick, Mitchell & Co. (General Coordinating Consultant), the Port of Seattle, and King County. This Study Team also included:

Project Manager-FAA  
 Technical Coordinator-Port of Seattle  
 Community Coordinator-King County  
 Airport Architect-The Richardson Associates (TRA)  
 Air Quality Consultant-Environmental Systems  
 Laboratories, Inc. (ESL)  
 Noise Consultants-Robin M. Towne & Associates  
 (RMTA) and Man Acoustics & Noise (MAN)  
 Public Opinion Research Consultant-Battelle  
 Institute Northwest  
 Solid Waste Consultant-Stevens, Thompson &  
 Runyan, Inc. (STR)  
 Water Quality and Drainage Consultant-STR, Inc.

Hundreds of citizens and property owners also contributed time, talent, and energy to the Sea-Tac Project. Their participation format is discussed next.

#### *HOW WAS THE COMMUNITY INVOLVEMENT PROCESS HANDLED?*

The community involvement program developed as an integral part of the Sea-Tac Communities Plan Project has been fully documented in a June 1975 report<sup>9</sup> prepared by the King County Policy Development Commission (PDC). A number of excerpts from that report have been selected and are reproduced below. While these

excerpts collectively provide an in-depth answer to the question as posed above, they do not cover all of the many details that are included in the full 37-page PDC publication.

"The area encompassed by the plan process can be characterized as a community without consensus. The community involvement program uncovered incredible levels of frustration and conflict. Not only has the community experienced frustration in dealing with King County and the Port of Seattle, but has also exhibited extreme conflict levels among its organizations and individual spokesmen. The two public meetings conducted at the outset of the plan was the first indicator of conflict and frustration within the community. At those meetings, over 1000 irate residents released a torrent of discontent, both with the Port and the County, and among themselves.

The Community Involvement Program responded to these circumstances by emphasizing, in its structure and activities, resolution of conflict. Functioning in an atmosphere of anger and distrust is not easy; the fact that the Sea-Tac Communities Plan Involvement Program has been as extensive, and has operated as successfully as it has, is testimony to the dedication of hundreds of citizens and the staff. The Program provided a forum in which King County and Port of Seattle officials and community residents could start talking to one another and begin to understand the position and problems of each. This brought about a reduction of distrust and afforded opportunities for channeling frustration into communications."

\* \* \* \*

"Approximately 300 citizens were actively involved in the project; some 220 working meetings were held. The number of meetings was not pre-planned at the onset of the project, mostly because the form of participation was in large part to be defined by the people involved. Most of the working meetings were relatively small, with five to fifteen persons attending. Bi-monthly committee meetings typically drew 25 to 40 persons. Every

attempt was made to involve the community in the project. It is estimated that approximately 3,000 people had contact with the Sea-Tac Communities Plan through the newsletter, questionnaires, committees and task forces, the community office, meetings, etc."

\* \* \* \*

"At the beginning of the study a local office was opened to serve as a focal point for community involvement for the duration of the project. The office has been managed by the community planner previously established in the area by the Division of Land Use Management; the community planner also served as community involvement coordinator. A full time planner from the Port of Seattle, two part time assistants, and many citizen volunteers have assisted in community functions at various times throughout the study. The establishment of a community office not only provided a visible sign of commitment to the community, but also served as a vital communication, information and activity center throughout the program."

\* \* \* \*

"The study was announced in metropolitan newspapers, in community newspapers and to community organizations. Further, all of the 36,000 property owners in the airport study area, received letters from the King County Division of Land Use Management (which provides staff assistance to the PDC) inviting their attendance at one of the initial two public meetings held to explain the purpose of the project. Also included was a questionnaire asking whether the recipient wished to participate in the project or to simply be kept informed on study progress.

The first two public meetings were attended by over 1,000 citizens. They were urged to fill out the questionnaire and over 400 did so. These people in turn received a second questionnaire asking them to state their preferred area of activity and involvement. From these responses, two general activity areas were defined: 1) airport and noise, and 2) community planning and water quality and drainage. This provided the basis for subsequent formation of ad-hoc citizen Air Transportation and Urban Development Subcommittees of the Land Use Committee.



These two sub-committees were the focal point of citizen involvement for the first six months of the project. Each was chaired by a member of the PDC Land Use Committee, with a community co-chairman. Membership on the two sub-committees exceeded 60. As the two sub-committees were taking shape, there were problems getting organized. There were the distrust, the hostility and frustration expressed by some of the participants and the problems of not really having much citizen activity while waiting for the inventory to be done by the staff.

The sub-committees, in the beginning, were to review the work done by staff, and it was a problem and source of real irritation for the community to have to start over each time new participants came to the meeting. Hearing the same gripes over and over again, i.e. 'The damn planes are so loud I can't hear the T.V.'. 'The vibrations are shaking my house to bits and pieces.'

Each sub-committee met on a regular basis; each defined its purpose and objectives. The two sub-committees reviewed technical presentations and studies, coordinated citizen efforts, developed action plans, performed studies, made recommendations, developed programs of benefit to the broader community, and organized special task forces. This early activity induced people to participate. Frustrations were released and a general cooling down occurred which allowed the community processes to become effective.

As the sub-committees began to become more familiar with the staff and the information available, certain activities were needed to help the major sub-committees function better. So task forces were formed, such as Administrative Task Force for Air Transportation, and Program Planning for Urban Development. These groups met with the staff to plan for the meetings, to assist in news releases, and for other duties as the need arose.

Some fifteen separate citizen task forces were formed at various times to discuss specific problem areas, and to provide advice to the project administration. Task forces met during the first six months of the study and reported their findings to the two sub-committees. The task forces served as catalysts that successfully broadened the base of

community involvement. The task forces brought the community together with representatives of all government agencies involved.

While data were being collected, people expressed concern that certain information was being overlooked. They would then get together to find out information, to write letters or talk to agencies to try and bring that information back to the sub-committees. Some examples of these task forces were the Historic Task Force, the Near Term Task Force, Real Estate & Taxes Task Force. Sometimes the task force would be only two or three persons. The Real Estate & Taxes Task Force wrote letters to banks and lending agencies to try and get an assessment of lending and mortgage policies around the Airport. The Near Term Task Force wrote letters to the Washington Congressional delegation attempting to get funds for acquisition. The Historic Task Force wanted to assure that the planning effort included the history of the area.

These task forces met as often as needed to meet their objectives. Their activities were effective because the citizens' expertise was utilized in the areas of their specialty. Individuals also felt a sense of accomplishment when one of their objectives was met."

\* \* \* \*

"Three half-hour video-tape programs on the environmental studies--noise, water quality, and land use--were produced by an Audio-Visual Task Force consisting of staff, citizens, and local audio-visual experts. This special activity was funded by King County and the Port of Seattle, exclusive of FAA funding. Titled Your 2 Cents Worth, these video-tape presentations were used as part of the Highline School District's Community Schools (Adult Education) Program.

The workshops were primarily intended to involve the broader community with the Sea-Tac Communities Plan. 24,000 brochures plus a clip and mail notice in the three local newspapers were used to inform the community of the workshops. About 150 persons signed up for the workshops and it is estimated that about 50 more dropped by with a friend, or through a spouse bringing along someone from their

family. The six-week program attracted the largest enrollment for a single series of classes in the history of the community schools program. Each of the six workshops was built around a particular issue, with information from available sources, such as the PDC, the League of Women Voters, Environmental Protection Agency. Each participant packet included a questionnaire/worksheet for discussion purposes."

\* \* \* \*

"How Would You Like to Sleep with a 747? was the provocative title of a television program produced as a public affairs function of one of Seattle's local TV stations. In conjunction with the presentation, surveys had been conducted and the results were discussed during the airing of the program. The intent of this effort was to acquaint the greater metropolitan area with the Sea-Tac Communities Plan, and to gather additional opinion through the survey. Sea-Tac citizens were involved in the planning and design of the questionnaire and the TV program. Of over 15,000 questionnaires distributed, more than 1,000 were returned -- an unusually good response."

\* \* \* \*

"At the end of Phase I [of the Project--data collection and forecasting], the results of community involvement activities of the first six months were published in a report entitled: I. Community Perceived Image, II. Community Expressed Concerns. This report indicated to the community that their concerns had been heard and noted and, although an interim report, it was visible evidence of their efforts."

\* \* \* \*

"After publication of the six month report, Phase II [plan development] was initiated. Participating citizens divided into four task forces according to their primary interests: Community Planning, Water Quality and Drainage, Airport Planning, or Noise Abatement. The task forces worked to define community needs, desires, and institutional constraints. These were translated into program ideas and combined into compatible sets. These in turn were examined and critiqued by the Analysts Task Force."

\* \* \* \*

"Each special task force would sift through ideas at one meeting and then the analysts (citizens from each task force and staff) would then go through each idea and also rate the ideas. Then the task force would review and rate the ideas. Sometimes there were several meetings in a week relating to a series of ideas. Many times after such discussion, several choices would be combined to become a goal. The task forces really were expressive and individuals were willing to pursue an idea. Strong feeling was expressed about individual preferences. The real commitment from the community was apparent when most of these citizens were at the task force meeting of their specific interest and many were at other task force meetings also."

\* \* \* \*

"At the initial meeting of the Community Planning Task Force, there were 110 possible program choices to work through. Each was an idea that someone wanted to promote. So meetings ran very late. The individual involvement was intense and many times the patience of other participants would wear thin. The citizens really complained when the meetings would get repetitious. However, the groups began to handle certain members when they considered them disruptive.

It was evident at these meetings that consensus was taking place and priorities were being established. However there were those who were in disagreement with some of the priorities that were being established by the group and there was sometimes impatience while new persons were brought up to date. Many times a person would come to one meeting, complain, and then leave. To the citizens who were working week after week this caused real frustration. They wanted to work through to a solution and not be just a center for complaints. Although they too were quick to do their own complaining if the staff got off of the groups priority."

\* \* \* \*

"The preferred alternative plans were presented to the community in a newspaper supplement entitled, Where Are We Going? included in four local newspapers with circulation totalling 70,000. The supplement explained the several alternatives and requested the readers to submit their reactions on an attached

questionnaire. Unfortunately, responses (slightly over 100) were not sufficient to reliably indicate trends in community opinion. However, the questionnaire did result in input from people who had been previously uninvolved in the program."

\* \* \* \*

"Applying the policy and plan alternatives to the geographic sub-areas was the major task of Phase III [plan assembly]. The participants were regrouped to represent the geographical areas north, south, east, and west of the Airport. The staff conducted meetings in the respective areas to gauge the effect of the proposed alternatives on specific neighborhoods. Citizen desires were then translated into implementation proposals and alternatives. By this time an increase of trust and respect between the community and planners had become more apparent."

\* \* \* \*

"To provide the community maximum access to information about the project, newsletters and 'fact sheets' on various studies and phases of the project were sent periodically to over 1500 residents. Articles in the local newspapers also appeared frequently describing progress on the project. Open houses were held on several occasions at the community office to encourage viewing of displays and to provide information. Additionally, field trips were arranged by staff to introduce interested citizens to various problem areas in the community."

\* \* \* \*

"The community office served as an outlet for loan copies of the working draft of the plan report. Throughout the writing period, revisions were made to these copies and loaned to interested citizens. Three community meetings were held in areas around the Airport during early June, 1975, to present the report. Questionnaires were used again, but centered on obtaining individual concerns on the plan's application to specific properties."

\* \* \* \*

"Citizens have influenced the planning process in the Sea-Tac project in several ways. Fundamental planning directions for the study area were developed from the citizen involvement described in this report. One of the most dramatic effects of citizen influence was the decision by the Port of Seattle to proceed immediately to develop acquisition plans for areas immediately adjacent to the Airport, instead of waiting until completion of the project to do so. Still another benefit is new pressure to establish and maintain on-going citizen involvement processes."

\* \* \* \*

"As is documented by this report, community involvement has been a thorough and continuing element of the Sea-Tac Communities Plan. It has demonstrated to the community and to the public agencies working together on the plan, the means by which concerned forces in a community can work together toward establishing appropriate goals and the means for moving together toward their realization. The Land Use Committee is pleased to confirm the achievement as described in this report."

\* \* \* \*

*HOW WAS THE COMPLEX ISSUE OF NOISE EXPOSURE TREATED?*

Although it was so organized as to permit every conceivable form of contact or "interface" between the Airport and the community to be evaluated--including such interesting subjects as tax base impacts, aesthetic considerations, solid waste management, and community attitudes--the Sea-Tac Study Work Program focused attention on the aircraft noise problem. This is not surprising in view of the litigational history associated with the Airport, strong citizen agitation for meaningful improvement in the noise environment, and a necessity to

make the Sea-Tac facility function as well as possible and for as long as feasible in its present location.

Since there was a great deal of confusion and misinformation in 1972 about the amount, type, and extent of noise attributable to the Airport, an extensive noise measurement program was included in the Study Work Program. Eventually involving some 4,400 measurements of individual aircraft operations under all weather conditions and during all seasons of the year, these measurements provided the basic input required for a detailed analysis of present and projected noise exposure patterns. Some of the more significant conclusions reached by the Project Noise Consultant as a result of this analysis<sup>10</sup> were as follows:

- Noise Exposure Forecast (NEF) methodology, with slight modification, is a reasonably accurate noise prediction model.
- The amount of territory impacted by aircraft noise will decrease over the 20-year planning time period (1973-1993).
- Fleet mix changes projected by the airlines which serve Sea-Tac<sup>11</sup> will have a beneficial effect in terms of noise reduction.
- Implementation of retrofit and flight operational alternatives (such as the two-segment approach) could significantly reduce the noise impact area beyond the reductions due solely to fleet mix changes.
- Selection of optimum runup sites and aircraft positioning can produce significant noise relief.

- At many locations throughout the Sea-Tac Study Area, vehicular and nonaircraft generated noises are equivalent to or greater than aircraft noise.

In essence, the noise analysis conducted as part of the Sea-Tac Project pointed up the fact that aircraft noise exposure had peaked and will be decreasing in the future. This is due largely to source changes in response to Federal Aviation Regulations Part 36 (Noise Standards).<sup>12</sup> Such changes include engine retrofitting, increasing use of new, quieter aircraft, and modification of current operating procedures. Moreover, the reduction in Sea-Tac generated noise exposure is projected to take place even though aircraft operations at the Airport are expected to double by 1993.

The use of refined NEF values based on actual measurements is another intriguing feature of the Sea-Tac Noise Analysis. These "calibrated" ANE (Adjusted Noise Exposure) values are more representative of prevailing local airport conditions than can be derived through the standard NEF process which utilizes noise-distance data generalized for different classes of aircraft. Furthermore, since the ANE margin of error is estimated to be  $\pm 2$  dB in contrast to the comparable NEF figure of  $\pm 5$ , the application of various noise control or noise remedy programs as part of an overall plan of improvement can be accomplished with a higher degree of confidence.



An additional variation employed by the Sea-Tac Study Team relative to noise exposure also needs to be described. Although aircraft noise was delineated on maps of the Study Area in the form of standard and adjusted NEF contours for each of the years 1973, 1978, 1983, and 1993, the use of a grid system to portray noise data proved to be of greater value in terms of plan implementation.

As partially illustrated by Figure 5, the Sea-Tac Airport noise consultants provided present and forecast ANE values for the midpoints of some 767 "cells", each of which represented 1/16th of a section, or 40 acres. These ANE cell values ranged from a low of 9 dB to a high of 58 dB. To cite one example, cell #0-9 (due north of principal Runway 16L-34R) moves from an ANE value of 45 in 1975 to 44 in 1978, 39 in 1983 (when full compliance with FAR-Part 36 is forecast), and 38 in 1993.

In terms of analytical capability and understanding, the grid system was more helpful than the standard NEF (or CNR) contour display for several reasons. First, an east-west/north-south gridiron format is similar to the way many communities lay out streets and subdivide property. This was indeed the case in King County and, as a result, a finer grain of land use analysis was possible.

Second, the ever-curving contour lines appear to delineate "absolutes" vis-a-vis noise exposure; that is, aircraft noise



is graphically portrayed as being a problem within the NEF 30 contour and not a problem outside of the contour. Although noise analysts can and usually do point out that such an interpretation is erroneous, community planners, public officials, and the lay public all too often do draw conclusions based on the "precise" locations of contour lines as shown on a map. A gridiron display more nearly reflects the fact that aircraft and other noise occurs over a wide territory and is not simply confined within certain "contoured" areas.

Third, the grid system aids in the determination of how to understand and thus deal with noise exposure conditions that are forecast to change over time. Figure 6 provides an illustration of this point. As may be noted, existing and projected noise exposure values for small or large areas can be readily indicated on a single illustration. The contour display process would require several transparent overlays (or one confusing multi-contour map) to depict the same information.

With regard to potential noise remedy programs that could possibly be applied to off-Airport areas--apart from aircraft operational changes--the Sea-Tac Study Team evaluated some sixteen different options. These options, which were also reviewed by numerous citizen and technical groups, can be consolidated into six categories of action. They are:

	N				O				P					
	40				44				37					
		39				43				36				
			37.8				40.5				35.0			8
				36				38				34		
					36				37				33	
1973 ANE	40				45				37					
1978 ANE		39				44				36				
SUSTAINED ANE			38.0				41.5				35.0			9
1983 ANE				37				39				34		
1993 ANE					36				38				33	
	40				46				38					
		39				46				37				
			38.0				42.8				35.8			
				37				40				34		10
					36				39				34	

figure 6. ANE GRID CELLS

1. Outright acquisition of noise-affected properties
2. Purchase assurance for impacted property owners
3. Acquisition of easements from impacted property owners
4. Insulation of noise-affected structures
5. Development controls by public agencies
6. Property advisory services

Of the six general categories listed, the purchase guarantee variation under #2 above received the greatest attention.

Through this type of program, residential property owners in prescribed noise exposure areas are to be given an opportunity to sell their holdings to the Port of Seattle if they desire to do so because of the aircraft noise problem. Once acquired, the Port will then sound insulate all living units, as appropriate, and offer the property for resale. An aviation easement will be attached to and become part of the property deed acquired by any new owner.

Such a program is to be concentrated in locations lying just beyond areas earmarked for outright acquisition where (1) a decline in aircraft noise to an "acceptable" level is slated to occur in the future, and (2) it is desirable from the public standpoint to preserve and reinforce a residential land use pattern. Affected property owners will have a choice as to whether they sell out or stay; if the latter, then they will

be eligible to receive a 100% noise insulation grant in exchange for an avigation easement, according to recommendations included in the adopted Sea-Tac Communities Plan.

Criteria for the application of all six categories of action have been developed with reference to the grid system of ANE values. As noted previously, Figure 6 indicates how these values were arranged for purposes of analysis on a portion of the Sea-Tac planning grid.

Based upon noise consultant findings and other sources, the Study Team developed specific criteria as to how and where the six noise remedy program categories could best be applied. Such criteria can be summarized as follows (refer to Figure 6):

1. Noise exposure areas permanently above ANE 40 (equivalent to an Ldn value of 75 dB) should be acquired outright to prevent any residential or other noise sensitive use. [Note: "Permanent" is defined as remaining at an ANE 40 or higher value throughout the 20-year planning period of the Sea-Tac Communities Plan.]
2. Areas exposed to sustained noise levels of ANE 40 or above should be eligible for purchase guarantee programs applied in conjunction with a residential soundproofing program and permanent or long-term avigation easements. [Note: A "sustained" level can be calculated by summing the four designated ANE values for a given cell and dividing by four. The resultant figure is not an average, but places somewhat more emphasis on present rather than future levels of exposure. In this instance, it defines exposure areas anticipated to fall below ANE 40 at some point during the planning period.]

3. For exposure areas permanently above ANE 35 (but below sustained ANE 40), a program of cost-sharing noise insulation assistance and easements should apply. Plan recommendations suggest that an eligible property owner could receive as much as 75% of all prescribed insulation costs in return for an appropriate easement. This is comparable to a British Airports Authority grants scheme now in effect around London's Heathrow Airport.<sup>13</sup>
4. For areas exposed to sustained noise levels of ANE 35 or above (but below permanent ANE 35), a program of cost-sharing insulation assistance and limited term easements should apply. Up to 50% of needed insulation costs could be granted to affected property owners under this particular criteria.
5. Programs involving special Development Controls (zoning, subdivision regulations, construction codes) and Property Advisory Services are to be applied within the Sea-Tac Airport Environs Area wherever an ANE value of 25 dB or higher is indicated.

The above criteria were then used to determine those areas within the Airport vicinity where one or more of the action programs are to be applied as soon as time, personnel, and dollar resources permit. In the adopted Plan version (see Sea-Tac Communities Plan Summary), some 481 acres were identified for potential acquisition by the Port of Seattle; 510 acres fell under the purchase guarantee category; 1,820 acres are deemed to qualify for cost-sharing insulation; and another 1,680 acres would be covered by a limited cost-sharing insulation program.

It should be noted that the citizens, technicians, and public officials who participated in the Sea-Tac Project ultimately

Faint, illegible text, possibly bleed-through from the reverse side of the page. The text is too light to transcribe accurately.



considered close to 70 different noise abatement program ideas. These ideas covered possible aircraft operational and technological changes, on-Airport ground operations and land use, airline industry policies, and off-Airport land use and development control techniques.

Note should also be made of the fact that every attempt was made to provide information in an understandable form to any participant who needed or desired such assistance. No question was viewed as being too complex to consider or too ridiculous to answer. It was this comprehensive and open approach to the aircraft noise problem that permitted the Study Team and others to gradually forge the consensus reflected in the adopted Sea-Tac Communities Plan.

*WHY WERE SOME NOISE REMEDY ACTIONS TAKEN PRIOR TO FULL COMPLETION AND ADOPTION OF THE PLAN?*

The Port of Seattle authorized an "Interim Acquisition Program" during Stage One of the Sea-Tac Communities Plan Project. Essentially a noise remedy action, this Program came into being during the fall of 1973 for several reasons, namely:

1. In June of 1972, the FAA approved the use of Airport Development Aid Program (ADAP) funds for the acquisition by local sponsors of certain lands adjacent to existing airport facilities. Sometimes referred to as "extended clear zones," eligible areas could be up to 5,000 feet in length (as measured from the end of a given runway's primary surface), and

as much as 2,500 feet in width (1,250 feet on either side of the runway centerline). Once acquired with FAA assistance, the land areas involved could only be used for activities or purposes that were compatible with present or projected airport activities.

2. Port management had wanted to expand the runway clear zones at Sea-Tac International Airport for some time in order to further improve the safety of aircraft approach and departure operations. However, the local cost of such an expansion was considered to be prohibitive prior to availability of the ADAP fund assistance described above.
3. Early meetings of the Sea-Tac Project had pointed up the fact that many citizens were extremely dissatisfied with Port policies relative to the aircraft noise problem. As documented elsewhere in this report, some of these citizens considered the Study itself to be simply a stalling tactic--they wanted positive action instead of a lengthy planning process.

An extensive program that encompassed the acquisition of 610 residential parcels and 75 acres of open lands located in high noise exposure areas was thus initiated in response to a combination of citizen pressure, operational need, and the availability of substantial federal fund assistance. With regard to the latter, estimates made at the time (1973) anticipated that some \$8 million out of a total projected cost of nearly \$16 million would be provided through the FAA.

Although the Study Team originally wanted to defer any acquisition effort until a definitive plan could be formulated, the decision made by the Port Commission to proceed with an interim

program proved to be correct. In the opinion of many participants, this early, positive action by the Port enabled the Sea-Tac Project to proceed in an orderly and productive fashion.

*WHAT ENVIRONMENTAL CONCERNS WERE ADDRESSED DURING THE SEA-TAC PROJECT IN ADDITION TO NOISE EXPOSURE AND WHY?*

The approved Work Program called for detailed water quality and drainage, air quality, and land utilization (including circulation) studies to be carried out during the initial 12 months of the Sea-Tac Project. In addition, a community attitudes survey was scheduled for completion within the first 90 days. Some key features of these special environmentally-oriented efforts are discussed over the next several pages.

Water Quality and Drainage

Much of Southwest King County was transformed from a rural to an urban area during the decades which followed the end of World War II. By 1973, citizens and governmental agencies in the Highline/Sea-Tac locale were trying to cope with a variety of problems that had been produced by this transformation.

Among other things, rapid airport, highway, and urban growth had created water quality and water quantity difficulties, especially in connection with the Miller Creek and Des Moines Creek waterways.

Since the Airport as well as nearby communities shared in this area of concern, the Sea-Tac Project was a logical vehicle for an in-depth study of water quality and drainage. As selected consultants for this study, the Seattle firm of Stevens, Thompson & Runyan, Inc. (STR) was charged with the responsibility of:

- a. Conducting a year-long (in order to account for seasonal variations) field study and sampling program that focused on chemical, biological, and hydrological properties of the subject creeks;
- b. Working with interested residents and property owners (primarily through the Citizens Water Quality and Drainage Task Force) in order to receive comments and ideas about problem areas, as well as to permit citizen review of study findings and recommendations; and
- c. Developing feasible solutions to water quality and drainage problems as part of the technical Study Team.

As documented in their report "Water Quality Analysis,"<sup>14</sup> STR in concert with the community, the Port, and the County, pinpointed a number of major problems. They were:

- Washington State Department of Ecology standards for Class A streams were violated at most of the chemical sampling stations; violations included temperature, dissolved oxygen, and coliform levels.
- The biological data indicated large populations of organisms tolerant of siltation and degraded water quality conditions in both creeks. Furthermore, few pollutant intolerant organisms were

found in either Miller or Des Moines Creeks, demonstrating an unbalanced and polluted ecosystem throughout the length of these streams.

- Based on staff gauge data, hydrologic measurements, and computer model runs, the two creeks were found to be grossly inadequate to handle even a relatively small storm; e.g., one having a duration of four hours and expected to occur an average of once every ten years.

In determining how best to deal with these problems, candidate solutions were considered in light of the desire by Study participants to (a) protect the natural function of streams and wetlands; (b) achieve and maintain natural stream flows; and (c) make the creeks suitable for recreational use. Qualities considered desirable for recreational waters are freedom from nuisance algal growths, noxious odors, and disease-producing organisms, while providing a resident fish population and a pleasant aesthetic experience for the observer.

With the above objectives in mind, a number of key policies were worked out to solve water quality and drainage problems. Stated in the form of action programs, some of these policies were as follows:

- Replace septic tank waste disposal facilities with sanitary sewer service as soon as possible.
- Assist permanent residential neighborhoods in the Sea-Tac Study Area to obtain sanitary sewers in conjunction with noise remedy programs.
- Contain and clean up accidental jet fuel spillage at or near the point of such spillage.

- Advise property owners (public and private) as to the proper use of fertilizers, fungicides, herbicides, and pesticides.
- Plant shade trees in unshaded areas of the upper reaches of Miller and Des Moines Creeks, and require shade tree planting along streams and wetlands in all new developments. In addition to their aesthetic value, the shade trees reduce water temperature which in turn helps the fish population.
- Require construction sites to have holding ponds for the temporary containment of storm water runoff.
- Coordinate roadway drainage systems with overall drainage plans and provisions.
- Establish a system of holding ponds to naturally control and maintain desirable stream flows. [The final land use plan clearly shows the holding pond system as recommended--see Sea-Tac Communities Plan Summary.]
- Monitor the effectiveness of water quality and water quantity solutions on a continual basis.

The Water Quality and Drainage component of the Sea-Tac Project was particularly well-received by all parties of interest. This was due to the availability of good technical data, a willingness to involve citizens in all parts of the process, and the emergence of logical and feasible improvement programs as end products.

#### Air Quality Analysis

A 12-month evaluation of air quality conditions in the vicinity of Sea-Tac International Airport was completed by the Sunnyvale, California, firm of Environmental Systems, Inc. (ESL).

Mobile vans and fixed stations were used to collect data on five air pollutants: particulates, carbon monoxide, hydrocarbons, nitrogen oxides, and oxidants.

The existing air quality in the Study Area and near the Airport passenger terminal was determined primarily from the measured data. In general, carbon monoxide and nitrogen dioxide were found to be below federal standards, while hydrocarbons and oxidants exceeded the national measures for such air pollutants.

In order to predict future pollution levels, ESL employed a computer model which required an emissions inventory and meteorological inputs (wind direction, speed, turbulence, and inversion) in addition to the above measured data. The emissions inventory included calculation of aircraft operation modes and times at the Sea-Tac facility, factors associated with each type of aircraft engine in use (now or in the future), and an analysis of pollutant quantities associated with the projected aircraft types and fleet mixes. Inputs to the model also encompassed pollutants typically generated by the operation of ground service vehicles; the storage and transfer of aircraft fuel; heating and other operations of the terminal complex; and the motor vehicles used by airport employees, passengers, and visitors.

The ESL model was employed to provide an indication of how air pollutants would likely be generated and dispersed about the Study Area in future years. This process involved "most probable" and "worst case" conditions based on air traffic forecasts and community plan alternatives. As was true with other parts of the Sea-Tac Project, numerous sessions were held with citizen groups to explain the process and to receive suggestions, ideas, and critical comments.

In their final report "Air Quality Analysis,"<sup>15</sup> ESL concluded that:

"The present and projected air quality near Sea-Tac Airport is not expected to pose any threat to human health as a result of airport operations. As the population expands and the communities around Sea-Tac grow, the combined effects of the Airport and communities may produce air pollution problems. Careful planning coupled with the implementation of available mitigation measures should prevent future air quality problems from developing."

Perhaps the chief value of the air quality study was the fact that everyone concerned about this particular subject had access to good data and a detailed analysis of the situation. For the first time, the role played by the Airport with respect to air quality in that part of King County was documented and reasonably understood. What had once been a confusing and potentially difficult issue was placed in proper perspective, as indicated by the above ESL conclusion. Moreover, the measurements taken during the study will serve as a baseline



against which future air quality conditions can be monitored and tested.

### Land Utilization

The King County Land Use Management Division of the Department of Community and Environmental Development executed a number of studies relating to the past, present, and potential utilization of land within the 44-square-mile Study Area. Existing trends and conditions were detailed in a preliminary document entitled "Six Month Report: Environmental Assessment."<sup>16</sup> Additional information was developed during subsequent phases of the Project and included as part of the final Sea-Tac Communities Plan report.

Both natural and man-made conditions were analyzed by the County planners in carrying out this part of the Project Work Program. With respect to natural factors that exert an influence on the utilization of available land resources, the analyses covered (a) the primary geologic processes responsible for surface relief; (b) predominant soil characteristics; (c) topographic and slope conditions; and (d) the type and nature of such potential hazards as landslides, erosion, and seismic disturbances. An extensive series of maps was also prepared by the County as a supplement to the "Six Month Report."

Man's prevailing land settlement and use patterns in the Area were similarly investigated and mapped. As noted in the final Plan document--

"Within the Sea-Tac area can be found commercial truck gardens, greenhouses, horticultural nurseries, small scattered pastures for horses and cattle, trailer parks, multi-story apartment houses, low income housing projects, luxurious mansions, large retirement home developments, lovely houses, ugly houses, a community college, public and private schools, playgrounds, parks, shopping centers, three large discount department stores, gaudy strip commercial developments, an outstanding library, cemeteries, golf courses, and a major international airport . . ."

Upon completion of land use and public facility surveys by the County in late 1973, it was determined that--

- Some 10,600 acres had been developed over time for single-family residential use at an overall average density of 3.02 dwelling units per acre.
- Although owner-occupied single-family homes represented the predominant residential form, approximately two-thirds of all new housing started in the 1960s involved duplex or apartment units.
- The largest business/commercial use concentrations occurred at Burein northwest of the Airport and along an eight-mile section of Pacific Highway South just east of the Sea-Tac boundary. The Burein complex contained some 450 retail stores at the time, while the highway strip consisted of a mixture of general and convenience business developments, including a cluster of motel/hotel uses near the passenger terminal entranceway.

- There was very little industrial development within the Study Area. As expected, the Sea-Tac installation was the single most significant nonresidential land use in the Area.
- A total of forty-three elementary schools, eleven junior high schools, seven senior high schools, and nineteen other educational facilities (including the 80-acre Highline Community College) were in operation at the time.
- The Area also contained eighteen County parks, seven municipal parks, a heavily used State park, eight County libraries, a district health center, and the King County Police Precinct #4 Headquarters at Burein.
- Fire protection throughout the Study Area was provided via nine special districts, four city fire departments, and the Sea-Tac Airport Fire Department.
- Five special districts, four municipalities, and the Airport proper had sewer collection and treatment systems, while water service was provided by means of fourteen incorporated water districts, three city systems, and the Airport.

The fact that numerous school facilities and a large number of special fire, water, and sewer districts were in existence within the Study Area turned out to be of major importance during plan development stages of the Sea-Tac Project. Airport land acquisition and clearance proposals were especially scrutinized by citizen, committee, and technical participants to ascertain the impact of such proposals on (a) tax revenue resources; (b) the type and level of public service that would remain (if any) after acquisition; and (c) the viability of affected residential neighborhoods.

### Community Attitudes Survey

A statistically valid community attitudes survey was carried out during Phase I of the Sea-Tac Project by the Battelle Institute Northwest in association with the University of Washington. Designed to produce an early, objective "reading" as to what citizens of the Highline/Sea-Tac area were especially concerned about, the survey was also undertaken to provide an indication of the extent to which aircraft noise was perceived to be a problem. The basic organization, conduct, and results of the survey may be summarized as follows:

- Three sample areas were selected for survey purposes.

The first area, designated as "Airport," was subdivided into high-, middle-, and low-noise zones (HNZ, MNZ, and LNZ) on the basis of actual measurements as provided by the Project Noise Consultant. The HNZ was defined as an area with noise exposure values in excess of NEF 35; the MNZ had NEF values of 25-35; and the LNZ was below NEF 25.

The second, or "Control," area was chosen because it lies some 40 miles south of the Airport (well out of range of aircraft-generated noise) and was similar in demographic characteristics to the Airport area.

Another comparison area, referred to as "County," involved a sampling of all residents of King County, including the City of Seattle.

- Some 302 interviews within the Airport area were conducted in person, as were 98 interviews in the Control area. A total of 316 County area residents were interviewed by telephone. Respondents were selected by means of accepted sampling techniques and

the following response rates were achieved: 84.1% (Airport); 83.7% (Control); and 67.1% (County).

- In order to prevent a respondent from being sensitized to the purpose of the survey, the schedule of questions contained no mention of the Airport, aircraft, or noise until the last part of the interview. Only if the respondent spontaneously mentioned noise as a disliked element or as a serious problem in the community did the interviewer pursue this topic further during the early part of the interview by asking for the perceived sources and effects of the noise. If the respondent did not spontaneously mention noise, the interviewer was instructed to broach this subject toward the end of the interview by asking: "Are you ever bothered by noise around here?" If the answer was yes, the interviewer then asked the same questions posed to the respondents who had mentioned noise at an earlier point.

Of particular importance in the study were specific questions about (a) the respondent's personal well-being and life-style, and (b) his or her views concerning the possibility of moving or remaining in the neighborhood under various conditions. A separate observational study was conducted in both the Airport and Control areas to obtain data on the manner in which aircraft noise might actually affect the outdoor living and recreational activities of residents in various neighborhoods.

In brief, the study compared the verbal and behavioral responses of residents living in communities that are relatively free of aircraft-related noise with those of residents who live in high-, medium-, and low-noise zones surrounding a major international airport.

- According to survey findings, aircraft noise was cited by 19.7% in the Airport sample as being the most important problem in the community. Additional concerns, as well as differences between the three test areas, are indicated below.

Responses to the Question, "What do you consider the most serious problem in this community right now?"

	Test Area		
	Airport	Control	County
1. No problem, satisfied, don't know	20.0%	32.7%	33.2%
2. Crime, vandalism, poor law enforcement	12.5%	13.1%	16.4%
3. Drugs	2.4%	2.2%	3.5%
4. Lack or failure of public services, sewers, drainage, fire, etc.	6.1%	1.1%	1.3%
5. Road and street maintenance and improvement	2.0%	2.2%	3.2%
6. Lack of recreation facilities and programs	2.0%	3.3%	.6%
7. Traffic	4.4%	4.3%	3.2%
8. Neighborhood not kept up, poor housing	2.4%	1.1%	4.2%
9. Noise, general, traffic, freeway	.7%	1.1%	2.9%
10. Airplane noise	19.7%	0.0%	2.9%
11. Taxes, school finance, economic	6.1%	16.3%	5.5%
12. Animal control	3.4%	4.3%	2.9%
13. Quality of people	2.7%	5.4%	2.3%
14. Poor planning	.3%	0.0%	1.3%
15. Poor public transportation	0.0%	3.3%	.6%
16. Miscellaneous	14.5%	10.1%	15.6%
Number of Observations	295	92	310
Number Missing	7	6	6

- The findings also yielded a clear correlation between noise level and those who reported noise as a problem or disliked feature in their community (HNZ-72.5%; MNZ-53.8%; and LNZ-31.8%). It was concluded by the Study Team, therefore, that objectively measured

aircraft noise correlates well with the reported experience of residents in the vicinity of Sea-Tac Airport.

- The proportion of residents who complained of various physical and psychological symptoms was nearly identical in noise-impacted areas around the Airport and in suburban or rural areas away from the facility, provided the respondents claimed to be bothered by noise. As observed in the Plan Report, "The source, nature, or amount of noise thus appears to be less important than the individual's vulnerability to noise."
- Responses to a question about who would remain in the local area if their home was sold also proved to be of more than passing interest, as reflected in the following table:

Percent of Respondents Who Would Remain  
in Local Area if Their Home Was Sold

Type of Response	Airport Area			Control Area	County Area	
	All	HNZ	MNZ			
1. Don't Know	1.4%	0.0%	1.2%	2.0%	1.2%	2.4%
2. Remain	45.0%	35.0%	48.8%	46.0%	64.2%	58.5%
3. Move Elsewhere	53.2%	65.0%	50.0%	52.0%	34.6%	39.2%
Total Observations	220				81	212
Number Missing	82				17	104

The above findings were particularly useful in determining the type of noise remedy programs that ultimately became part of the Sea-Tac Communities Plan.

Although the Attitude Survey was not completed as soon as originally scheduled, the results of this effort were deemed to be of significance and value to Project participants. Perhaps the best summary of the study appeared in the final Plan report . . .

"The effects of aircraft noise appear to be rather localized, although the specific effects on the life-style and psychological well-being of the resident are far from clear. A substantial proportion of respondents in the High Noise Zone complain about psychological effects as well as property damage. However, many others who choose to live there seem able to tune out the noise of airplanes or to ignore them in their daily lives.

"The residents in the High Noise Zone are obviously affected by aircraft noise and a seemingly deteriorating neighborhood. Beyond this, there is no marked evidence that the community attitudes toward the Port of Seattle, toward local government, or toward the environment, are strongly influenced by living in the general vicinity of the Airport. At least insofar as the data from this survey seem to indicate, the Airport appears to have relatively little adverse effect on the community lying outside the immediate areas of high noise impact."

*WHAT TECHNIQUES WERE USED TO EVOLVE A PLAN THAT WAS GENERALLY ACCEPTABLE TO ALL PARTIES OF INTEREST?*

With so many diverse interests involved, the ability to work out a consensus plan and improvement program represents one of the Sea-Tac Project's most singular achievements. While many, many individual factors could be cited to account for the reaching of consensus, a number of techniques employed during the Project proved to be especially helpful and worthy of



mention. These particular techniques are generally described over the next several pages.

#### Regular Meeting Format

Beginning in March of 1973, Study Team representatives met in Seattle on the first Monday of each month to discuss Work Program progress, coordination procedures, and any special problems or observations worthy of note. These meetings were prescheduled over the life of the Project (originally 18 months) and were conducted in addition to any work conferences that may have been needed in carrying out specific tasks.

Both the Technical Advisory Committee and the Policy Advisory Committee also met not less than once per month during the Project. The TAC was convened at 10:30 a.m. on the first Tuesday of each month in the Community Office (located at Burein), while the PAC got together on the same day at 2:00 p.m. in the Sea-Tac Airport Conference Room.

In addition to his many other responsibilities, the Technical Coordinator (a Port employee) distributed agendas in advance of the aforementioned meetings, and also saw to it that all who were interested received minutes in a timely fashion-- usually within two weeks. Then too, the Community Coordinator (a King County planner) briefed all three groups at their respective monthly sessions as to the Community Involvement Program. Note should also be made that all meetings were open;

citizens and/or others were not only permitted to attend, they were encouraged to do so.

As anticipated by the Project Study Design, the above meeting schedule, format, and process worked well. Among other things -

- Technical, advisory, and citizen participants moved together throughout the Project; all of the various interests received needed information in a generally uniform and timely fashion.
- The "open forum" atmosphere that was encouraged by the TAC and PAC Chairmen helped to produce a feeling of meaningful (rather than meaningless) participation, especially on the part of citizen members and attendees.
- The resolution of differences was facilitated by the fact that no group ever went for more than one month without a meeting. Little issues were taken care of in many instances before they could grow into major problems of a disruptive or Project-delaying nature.
- A flexible rather than rigid approach to committee membership was maintained throughout the Project. The PAC, for example, was originally composed of less than ten persons but had some 23 members at the end of the Sea-Tac Study. If an interest group was identified during the Study that needed to be represented on either the PAC or TAC, such representation was accommodated.

#### Good Data Collection and Dissemination

Prior to the Sea-Tac Project, a great deal of confusion existed within the Airport Environs Area with regard to basic data and information. As might be expected, the many and varied groups

active within (or on behalf of) the area frequently had differing views as to noise exposure, air quality, water quality, drainage, and/or traffic conditions. In some cases, competing interests had each employed "expert" sources who often reached conflicting conclusions as to what a given situation was or should be.

In recognition of this state of affairs, the Sea-Tac Project Work Program provided for a comprehensive data collection effort to be accomplished in an objective fashion by unbiased professionals preeminent in their respective fields. As has been reviewed, year-long noise exposure, air quality, and water quality measurements were openly obtained, organized, and disseminated to all who expressed a desire for such information. Newsletters, fact sheets, workshops, video tape programs, educational courses, newspaper articles, and many other techniques were employed during the Project as part of the dissemination process.

Moreover, the Study Team consciously tried to answer each and every question about technical matters in a satisfactory manner--even if the question appeared to be of the ridiculous or frivolous variety. In short, every effort was pursued to ensure that good information was first obtained and then made available to the maximum extent possible.

### Citizen Involvement

The extensive Citizen Involvement Program described earlier in this report clearly proved to be a major factor in the evolution of an acceptable Sea-Tac Communities Plan. However, a few additional comments need to be made in order to place this part of the overall Project in its proper perspective. They are:

- While the Program was structured to provide citizens with maximum opportunity to participate, and to permit them to take part in the planning process according to their own degree of interest and availability, it was not allowed to "take over" or dictate actual Work Program progress. Citizen participants were advised from the start that they would have to "keep up" with the Project Schedule.
- The success of the Community Office must be attributed to the dedication and enthusiasm of citizen volunteers and public employees who staffed this facility. Long, irregular hours involving many night and weekend meetings were the rule rather than the exception.
- To the maximum extent possible, every citizen question was answered and every citizen idea was given consideration during the Project. Nonetheless, the final Plan did not overly reflect citizen desires at the expense of public capabilities and priorities.
- Although some 140,000 persons resided within the original Study Area, just 3,000 were considered to have directly participated in the Sea-Tac Project. As a result of their involvement and education, however, these 3,000 activists were able to adequately represent citizen interests during every stage of the effort.

### Forecast Coordination

The Study Team recognized from the beginning that Work Program tasks relating to forecasts of future activity and change would be of prime importance in the development of a consensus plan for the Sea-Tac Airport and Communities Area. This was especially the case with regard to the anticipated future mix and volume of aircraft operations at Sea-Tac, since these particular forecasts provide the basis for making near- and long-term projections of aircraft noise exposure.

In order to properly coordinate this important forecast process, a number of day-long workshops were held during Phase I of the Project. In addition to Port of Seattle and King County planning, research, and legal personnel, these workshops included representation from:

- a. PMM&Co., the consulting firm responsible for producing forecasts of future aviation-related activity;
- b. The air carrier airlines serving Sea-Tac International Airport;
- c. RMTA and MAN Acoustics & Noise, the consulting firms responsible for noise measurement and analysis;
- d. Appropriate FAA components such as the Regional Airports Planning group and the Sea-Tac Tower staff;
- e. Airframe manufacturers (e.g., the Boeing Aircraft Company);
- f. Puget Sound Governmental Conference (PSGC), the agency then responsible for region-wide forecasts of population, employment, and aviation activity; and

- g. Key citizen groups such as the Zone Three Committee member on the Policy Advisory Committee.

Although the coordination workshops were somewhat lengthy and time-consuming, they unquestionably played a major role in the evolution of an acceptable Plan. Agreement was reached through these sessions as to (1) the number and type of aircraft (including potential new equipment) that could be expected to operate into and out of the Sea-Tac Airport in specified future years (1978, 1983, and 1993); (2) when full compliance with Federal Aviation Regulations Part 36 could be anticipated; and (3) what flight patterns and aircraft operating procedures could best be utilized in future years to reduce or better control noise generation.

Yet another prime benefit of the workshops was the education received by the various parties of interest. All who took part came away from the meetings with better knowledge of, and a healthy respect for, the complexities of forecasting change relative to a large hub international airport.

#### Airline Inputs

The air carrier airlines which serve Sea-Tac International Airport contributed to the Project in a timely and effective fashion. Coordination of airline inputs was handled by United Air Line's Director of Facilities and Airport Planning, a member of the Technical Advisory Committee. In addition to TAC,

the coordinator also worked closely with the airlines permanent Airport Affairs Committee, primarily through the latter's representative on the Sea-Tac Project's Policy Advisory Committee.

Three resource panels were formed to assist and advise the airlines coordinator. One of these panels focused on airside matters, a second on noise considerations, and a third on land-side factors. Air Transport Association (ATA) and aircraft manufacturing specialists were included in these resource groups in addition to airline expertise.

Airline participation during the Project focused on (a) review of Study findings and recommendations, and (b) resolution of questions on forecasts, noise study assumptions, and plan implementation. As noted by the coordinator on several occasions, airline participation was more extensive throughout the Project than at any other airport. This was due to a combination of factors such as:

- The Sponsors (Port of Seattle and King County) were seeking maximum participation through frequent meetings open to all--a situation that seldom exists.
- The amount and type of publicized litigation relative to Sea-Tac provided an indication of substantial pressure on the Port to purchase additional property in the Airport vicinity, a matter of financial import to the airlines.

- Then current (1973-74) studies at other airport locations often utilized faulty analyses as derived by consultants and others without the benefit of airline input. Among other things, this included the use of gross take-off weights when not appropriate, assuming excessive increase in daily movements, etc.

All in all, the thorough and professional manner in which airline inputs were made available during the Sea-Tac Project greatly aided in the development of consensus positions. Stated in another way, the Sea-Tac Communities Plan would not have been as complete, as practical, and as "do-able" in the absence of such inputs.

#### Plan Alternatives Process

An innovative process that allowed all interests to take part in the evolution and consideration of plan alternatives was developed for use during the Sea-Tac Project. Essential features of this process were as follows:

1. Overall planning standards or criteria to be used in the evaluation of plan alternatives were first agreed upon by the Port of Seattle, King County, and the FAA.
2. Four key program areas were also agreed upon: Community Planning; Airport Planning; Water Quality and Drainage; and Noise Abatement. A citizen task force supported by designated staff personnel was established in connection with each program area.
3. Future conditions based on a continuation of prevailing trends were projected by the County planning staff for the years 1978, 1983, and



1993. One purpose of these baseline futures was to determine minimum requirements necessary to meet or accommodate forecast changes in population, employment, housing, and land use.

4. The process of modifying the baseline futures by means of a coordinated Airport/Communities Plan was initiated through the assembly (by program area) of specific ideas for improvement. Essentially singular alternatives, these program ideas were derived from both technical and citizen sources. Each had a single purpose at this point in the Project, and had not been tested for its feasibility, interrelationships with other ideas, or its compatibility with certain given factors or conditions. A particular idea could relate to land use, circulation, aircraft operations, noise remedies, or any other subject pertinent to the Sea-Tac Project.
5. Program ideas were internally developed by the aforementioned citizen task force groups, who also considered suggestions by staff, outside resources (e.g., consultants, agencies, etc.), and the greater community. Ideas formulated and reviewed by the citizen groups were transmitted to a special Analyst Task Force which was comprised of (a) key Port, County, and consultant Study Team participants, (b) one representative from each of the four program task forces, and (c) a member of the King County Policy Development Commission's Land Use Committee.
6. The Analyst Task Force was charged with the responsibility of screening program ideas in light of factors derived by data analysis and knowledge of existing policies, opportunities, and limitations. Initial program choices were made by the Task Force and documented in the form of idea cards color-coded by program area. Each card carried one of the following notations:
  - Rejection (with justification)
  - Acceptance (with conditions)
  - Acceptance (with justification)

7. Individual program choices were reviewed by the Technical Advisory, Policy Advisory, and Land Use Committees, all of whom fed back their comments and suggestions to the Analyst Task Force. The latter then conducted detailed analyses of program choices that conceivably could be grouped together and applied as part of an overall plan of improvement. These "mix-n-match" analyses focused on cause-effect and cost-effectiveness relationships in order to achieve optimum combinations of program choices. Such combinations were referred to as program sets.
8. Following further review and feedback by Project committees and community groups, modified program sets provided the basis for development of the projected futures reflected in and by the finally agreed-upon Sea-Tac Communities Plan.

As illustrated by Figure 7, the above process of developing, considering, and selecting plan alternatives was iterative by design, a fact which greatly aided in the achievement of consensus. A new or revised program idea could still be recycled and receive proper consideration even if it emerged as late in the process as the "final" review by PAC of program-set recommendations.

#### Improvement Program Terminology

Residents, property owners, and other citizen interests understandably focused most of their attention on the environs part of the Sea-Tac Project. In recognition of this fact, the Study Team tried to use commonly understood terms wherever possible. For instance, the notion that "ideas" needed to be developed and reviewed during step one of the Plan Alternatives

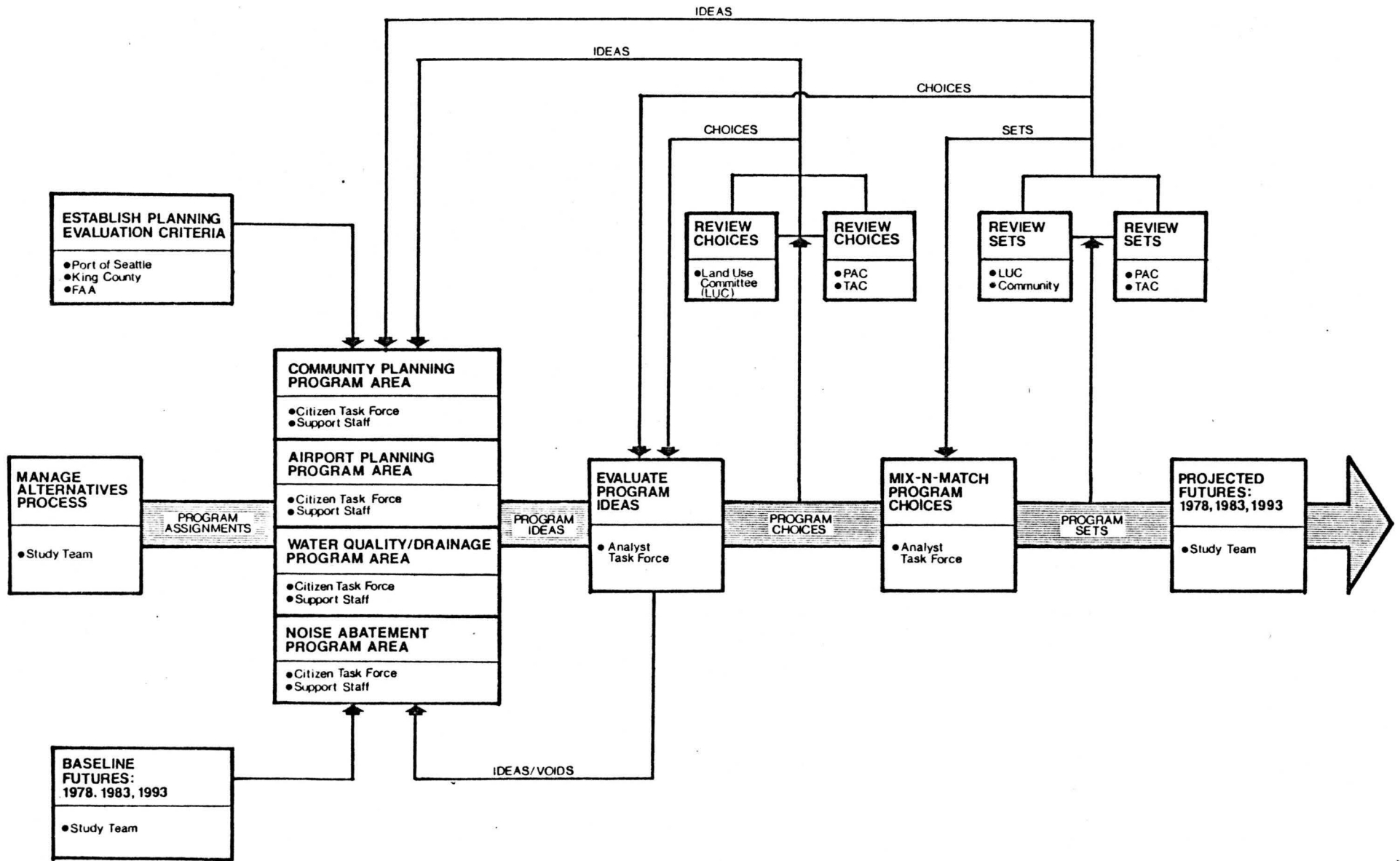

FIGURE 7. SEA-TAC PROJECT: PLAN ALTERNATIVES PROCESS

Process (Figure 7) was encouraged by the Team in contrast to the more typical goals/objectives/policies planning approach that might have been followed.

Also, the three primary community improvement programs that were agreed upon had names designed to promote understanding and thus consensus. They were:

1. Acquisition of land by a public authority--the most direct form of land use change encompassed by the Plan;
2. Conversion of property over time by private owners to uses that are as compatible as possible with the operation of a major airport; and
3. Reinforcement of existing land use patterns primarily by means of public program "sets" or combinations that are carried out by responsible governmental agencies.

As detailed in the final Plan report, the second program above is perhaps the most difficult to achieve, while a majority of citizen participants wanted the last program applied to their neighborhood as soon as possible. While not the only factor by any means, the term "reinforcement" was useful in promoting support for the public actions needed under this form of improvement program.

#### Sector-By-Sector Public Meetings

During final stages of the planning process, meetings were conducted on a sector-by-sector basis in order to encourage

maximum public review of Sea-Tac Communities Plan recommendations. These meetings were held during evening hours in convenient locations to the north, east, south, and west of Sea-Tac International Airport.

This localized approach permitted affected resident and property owners to focus on those suggested Plan improvement programs of greatest consequence to their particular interests. As a result, potential problems were identified and resolved more readily than would have been true via the use of only one location for such presentation and review sessions (e.g., the Community Office or the Airport Terminal).

#### A Single Airport and Communities Plan

Yet another tactic that aided in the development of consensus was the fact that the master plan for Sea-Tac Airport and surrounding communities was fully blended into a cohesive whole. Neither the Airport nor the communities received "feature billing" in the adopted Plan. Rather, a co-equal sharing of problems, opportunities, and future improvements was reflected in all parts of the Final Plan document. This important point is best indicated by the Land Use Plan illustration included in the Plan Summary. As may be noted, the actual Airport boundary is not represented in any way, form, or manner on this plan map.

To sum up, consensus was achieved when necessary during the Sea-Tac Project because the plan development process was (a) open and aboveboard, (b) factual and comprehensive, and (c) carried out by reasonable public officials, planning technicians, and citizen participants.

*WHO WAS DESIGNATED TO FUND AND CARRY OUT PLAN RECOMMENDATIONS?  
WITH WHAT RESOURCES?*

As clearly set forth in the Sea-Tac Communities Plan report, the Port of Seattle Commission and the King County Council will have the primary responsibility for implementation of recommended Plan programs, projects, and activities. However, full implementation of the Plan is contingent (in part) on the realization of certain basic assumptions. They are:

1. Both the Port of Seattle and King County will generally schedule and fund recommended projects via their normal budgeting and capital improvement procedures, rather than by special bond issues or increased tax levies.
2. The FAA's Airport Development Assistance Program (ADAP) will be utilized to the maximum extent possible in the funding of all eligible projects.
3. The rate of Plan implementation will of necessity be dependent upon the availability of required time, personnel and dollar resources of the Port, County, and other participants (public or private).

4. Results of proposed demonstration efforts (such as the acoustical insulation test project), as well as the ongoing noise exposure, water quality and air quality monitoring programs, may be expected to affect initial timing, cost, and responsibility assignments in future years.
5. Future Port Commissions and County Councils will continue to support needed Post-Plan administrative functions.

Total estimated costs (in 1975 dollars) over the 20-year period from 1976 to 1995 amount to some \$157,863,000. Of this total, over \$48 million is slated for noise remedy programs, nearly \$8 million for public projects within the Sea-Tac Communities Area, and in excess of \$101 million for on-Airport improvements.

*Was the Sea-Tac Communities Plan Formally Adopted? By Whom?  
In What Form?*

On June 8, 1976, the Seattle Port Commission adopted Resolution No. 2626, which was entitled "A RESOLUTION of the Port Commission of the Port of Seattle establishing certain planning and developmental policies and guidelines relating to Sea-Tac International Airport and its vicinity as developed in the Sea-Tac/Communities Plan."

A similar action was taken by the King County Council on September 20, 1976. At that time, the Council passed Ordinance No. 2883, to wit: "AN ORDINANCE adopting the Sea-Tac

Communities Plan as an addendum to the King County Comprehensive Plan for the future growth, development, and redevelopment of Sea-Tac International Airport and the surrounding communities."

As required by state law in Washington, an Environmental Impact Statement (EIS) which examined anticipated effects of the Sea-Tac Communities Plan was prepared prior to adoption of the Plan by either the Port or County. The preparation of this EIS required several weeks of time beyond completion of the Sea-Tac Project in mid-March of 1976.

The Plan report which was adopted in its entirety by both the Port Commission and County Council was produced in the form of a red-covered 3-ring binder notebook. This 3-inch thick notebook was subdivided into the following parts:

1. Overview of the Plan
2. Use of The Report
3. Background
4. Trends and Forecasts
5. The Environment
6. Plans, Policies and Programs
7. Implementation
8. References



In addition to the adopted Plan document, the EIS, and the Plan Summary previously mentioned, some 28 separate technical reports were produced during the Sea-Tac Project. Eight (8) special pamphlets were also developed by the County and Port for use during the plan alternatives process.

*HAS THE PLAN BEEN FOLLOWED DURING THE TIME THAT HAS PASSED SINCE ITS ADOPTION?*

In essence, the answer to this question is yes. Although the Port and the County have had some differences of opinion since the Plan was adopted in 1976, a wide variety of actions have been taken in accordance with Plan recommendations.

They include:

- Some \$12 million has been committed by the Port of Seattle and the FAA for the purpose of acquiring properties subject to high noise exposure (NEF 40 and above throughout the entire 20-year planning period).
- Of the 600 homes on 699 parcels of land scheduled for acquisition by the Port, some 350 have already been obtained. As required by the Uniform Relocation Act of 1970, relocation assistance in connection with the acquisition program has been provided by the Port. Indeed, a fulltime staff of six persons has been employed to deal with this important responsibility.
- The U.S. Department of Housing and Urban Development (HUD) is tailoring its home mortgage commitments to Plan recommendations. This has helped to relieve the "climate of uncertainty" that plagued property owners

prior to the Sea-Tac Project. Of course, a marked improvement in the overall Seattle area economy has been taking place since 1975. This has resulted in a strong demand for housing throughout the Puget Sound Region, including the Sea-Tac Airport/Highline area of King County.

- Additional authority to permit the Port of Seattle to expend funds for such off-Airport purposes as sound insulation has been granted by the Washington State Legislature.
- A pilot program designed to test the actual effects and costs of residential sound insulation is under development at the present time. This program will soon be initiated by the Port.
- An extensive noise monitoring system is also in final stages of development. Appropriate specifications have been prepared and bids are scheduled to be let this Fall (1977). Funds have already been budgeted for this purpose by the Port Commission.
- King County is now beginning work on zoning and building code revisions as recommended by the Sea-Tac Communities Plan. This task has been delayed somewhat by a recent reorganization of County departments, including the planning and land use management functions.
- The County has delineated specific park and recreation projects in accordance with the adopted Plan. In addition, holding pond and drainage improvement needs that were pinpointed during the Sea-Tac Project have been further detailed by King County as part of its current Highline Middle Plan effort. Among other things, consideration is being given to the establishment of an areawide drainage district with the power to levy a special tax based on the extent of pervious/impervious surface associated with a given piece of property.
- Some 25,000 trees have been planted within designated Airport buffer areas by local Boy Scout organizations.

- Aircraft runup positions on the Sea-Tac airfield have been changed in response to Plan recommendations. Also, such engine runup activities are no longer permitted during nighttime hours (11 p.m. to 7 a.m.).
- A special committee function has been established by the Port to assist in the consideration of "hardship" cases within the land acquisition area. Comprised of citizen members for the most part, the Committee reviews such cases and makes recommendations thereon to the Port's Real Estate department. Approval for earlier acquisition than called for by the schedule is granted in about one-half of the cases heard by this committee. The Port has earmarked some \$150,000 in support of the foregoing hardship process.
- According to the Real Estate Department, most of the people they now deal with are fully aware of the Sea-Tac Community Plan and understand its influence on them. Moreover, the Plan is increasingly being referred to and cited in those noise litigation cases still in process.

While the preceding list is impressive, not every aspect of Plan implementation has taken place as anticipated or programmed. As noted earlier, differences of opinion about the extent of certain Plan provisions have cropped up between the Port of Seattle and King County. These variances have focused on land use matters along the Airport's western boundary, on a small industrial area to the northeast of Sea-Tac, and on the question of whether the Port should or should not acquire and clear industrial/commercial properties as well as residential parcels within the acquisition program areas. In almost every instance, the differences can be

traced back to what seem to be conflicting passages in the final Plan report--a problem that probably could have been resolved by a better editing process.

As often seems to be the case when an acceptable and successful planning product is finally available for use, certain interests are dissatisfied with the pace of Plan implementations. Some of the citizen participants, for example, wonder when the Port intends to begin the Property Advisory Services Program outlined in the final report. Also, there is concern that the County has neglected its responsibilities somewhat due to its preoccupation with other pressing matters and issues.

When everything is considered, however, the subject Plan has unquestionably provided positive guidance to private and public interests alike since its adoption in 1976. As noted by one of those interviewed for this report, the Port of Seattle alone has already committed about \$30 million to the improvement over time of conditions within the Sea-Tac Airport environs area. In all likelihood, this sum of money would not have been budgeted except for the presence of a feasible course of action as embodied by the Sea-Tac Communities Plan.

*WHICH PROJECT ACTIVITIES PROVED TO BE ESPECIALLY USEFUL? WHICH ONES WERE UNPRODUCTIVE? WHAT ELSE SHOULD HAVE BEEN DONE?*

Several key participants in the Sea-Tac Project were interviewed for purposes of this evaluation report. Perhaps the

best way to answer the above three-part question is to outline the various suggestions that were obtained during this interview process. These suggestions, as listed below, are not arranged in any particular order of importance but they have been grouped according to general subject matter.

- More time and effort should have been devoted to the "education" of news media representatives who covered the Project.
- Response to the questionnaire contained in the newspaper supplement Where Are We Going? was very disappointing and of little value (see p. 32). This was due to the fact that most people lead busy lives and simply won't take the time required to fill in and mail a written questionnaire form.
- A glossary of technical terms and an explanation of same in lay terms would have been most helpful to citizen participants.
- The Sea-Tac Tower Chief benefited through his direct involvement with citizen interests and vice versa.
- Citizens need to be reminded often that their role is to provide input and advice to the Project and not to make actual policy decisions.
- A large, colored version of the Project Activity Flow Diagram proved to be a useful device to show citizens how the Project was progressing over time. In many instances, this diagram (located in the Community Office) was used by a citizen participant to explain the Project to one of his or her newer counterparts.

- The Community Attitudes Survey was not completed as scheduled (within three months after start of Project) and therefore was not as useful as it should have been.
- Two kinds of attitude surveys are needed--one up front to help structure the activity program and one later on to assist in the evaluation of plan alternatives.
- Airline input was of great importance and value to the success of the Project (comment by a citizen participant).
- Project committees should not be "saddled" with too many by-laws or procedures that are rigidly followed; flexibility as to membership and other organizational matters is more important.
- Citizen representatives on Project committees need to function as, and clearly reflect, general rather than special interests.
- The 40-acre grid size used in the noise analysis was too large; if possible, a 10-acre cell size is better for purposes of detailed planning.
- An easier-to-understand and more versatile noise descriptor system than the NEF process should be used, such as the Day-Night Average Level (DNAL--often called LDN) metric.
- Elective officials should have been more deeply involved in the Project's final stages than they were; unfortunately, other issues and programs began to interfere with the Sea-Tac Communities Plan review and approval process.
- The Project was almost too long--technical and citizen participants were tired after almost 24 months of continuous effort. A "let's get done with the job ASAP" philosophy prevailed at the end which, among other things, resulted in a final plan document that was not properly edited. As a consequence, disagreements between the Port and County as to the intent of certain plan recommendations have surfaced in recent months.

- The detailed plan report, as produced in a large three-ring binder format, has given some problems simply because subsequent changes have not been reflected as yet by appropriate replacement pages. Experience to date has also indicated that the final plan report should have been (a) more carefully edited, and (b) bound for the record upon adoption by the Port and County.
- Clearer reference to the Sea-Tac Airport Layout Plan (ALP) should have been included in the Plan report. Also, a reduced version of the ALP should have been produced and bound into the final document.
- The difference in timing between adoption of the Plan by the Port of Seattle (early June 1976) and King County (late September 1976) resulted in interpretive variations that have tended to delay Plan implementation to some degree.
- Ways and means to amend the Plan by either the Port of Seattle or King County were not addressed during the overall Study. This glaring omission has created certain problems and differences of opinion since the Plan was adopted in 1976.
- A contingency fund should be established in connection with projects as long and complex as the Sea-Tac effort. Among other things, such a fund could be used to pay for small special studies that cannot be identified in the beginning but become apparent as time passes. Examples include market analyses, housing studies, site design, additional surveys, etc.
- Implementation of noise remedy programs needs to occur on a "first things first" basis because of dollar limitations. That is, high priority land acquisition should take place prior to any noise insulation activities.

### III. CONCLUSION

#### *WHY THE SEA-TAC PROJECT WAS SUCCESSFUL*

No "magic," single reason can be given as to why the Sea-Tac Project turned out to be successful and worthy of study. As might be expected, many factors were involved, some of which have been noted in the answers to key questions provided in Part Two of this report. It is clear, however, that the Sea-Tac effort was:

1. Conceived at the right point in time for the Port of Seattle, King County, the FAA, and the residents of communities within the Airport environs area;
2. Guided by a Work Program comprehensive enough to deal with almost any concern or issue;
3. Conducted in an open, forthright manner that permitted maximum participation and also instilled confidence in the planning process;
4. Technically executed by competent professionals (public and private) whose experience permitted them to innovate where necessary in order to solve problems and capitalize on opportunities;
5. Positively affected by the observations, ideas, and time furnished by the many citizens who took an active part in the Project;
6. Improved as a result of the cooperation and assistance afforded by such interests as the King County Policy Development Commission, the Zone Three Committee, and the airlines which serve Sea-Tac International Airport; and
7. Strongly supported by top elected and/or administrative officials of the Port Commission, the County Council, and the Regional FAA Office.



Another measure of the Project's success is the belief by many that the four specific objectives listed on pages 22 and 23 were indeed accomplished after two years of hard work. However, the overall goal of making the Airport and Community better neighbors is heavily dependent on the degree to which the Sea-Tac Communities Plan is actually carried out. As a consequence, time must pass before judgments can be made about the long-term usefulness of the Sea-Tac Project.

*IS THE SEA-TAC APPROACH APPLICABLE ELSEWHERE?*

Numerous aspects of the Sea-Tac Plan development approach could be productively applied in other locations which have a need to address airport/environs conditions and issues. For instance, the use of a comprehensive work program and the plan alternatives process could well have value elsewhere, as could the notion that all planning activities and decisions should take place in an open rather than closed environment.

Of equal importance is the fact that many features of the Sea-Tac Project may not be pertinent in other settings. Only two major governmental bodies were required to sponsor and be actively engaged in the Seattle undertaking, whereas a similar effort in connection with Hartsfield International Airport in Atlanta would involve at least two counties and as many as eight separate municipalities. Among other things, the

Atlanta institutional framework would necessitate very different funding, project management, and decision-making arrangements than were employed in the Sea-Tac Project.

To state the obvious, each airport environ planning situation is unique and should be treated as such in determining how best to develop a coordinated plan of improvement. While the intent of this report is to provide detailed information about one project that worked, the Sea-Tac approach should not be blindly adopted just because it was successful. Rather, a comprehensive program of activities and participation should be tailored in accordance with local needs, desires, and conditions.

#### *SOME IMPORTANT LESSONS*

The Sea-Tac Communities Plan experience, as described in this report, is useful in many ways. In addition to the how, what, when, and who questions previously addressed in Parts One and Two, several additional lessons of importance that stemmed from the Sea-Tac Project need to be cited. In capsule form, these lessons are:

- The airport sponsor's attitude is critical. There was a distinct recognition by the Port of Seattle Commission and management that the issue of airport/community compatibility was so important that it required a substantial amount of time, attention, and dollars, as well as an open and cooperative approach.

- Maximum opportunity for citizen participation in the planning process is important. This does not imply one must go door-to-door and plead with people to take part, but it does mean that many techniques ought to be applied that both permit and encourage participation.
- Fair consideration must be given to all logical planning alternatives--including null or "do nothing" options. Unfortunately, plan alternatives as presented all too often reflect unrealistic economic features and/or inbred biases of the technicians responsible for the preparation of such alternatives. While this observation could be made with reference to almost any type of project, it has special relevance in the field of airport environs planning.
- Implementation of the numerous recommendations typically generated by the development of a comprehensive airport/environs plan must be addressed as a shared responsibility. The airport sponsor should not be expected to shoulder the entire financial and coordination burden. Appropriate local, regional, state, and federal governmental entities need to be involved in plan implementation, as do affected property owners, special interest groups (chambers of commerce, environmental protectionists, taxpayer organizations, etc.), and the general public.
- There should be a clear understanding that completion of a particular airport/environs plan does not signal an end to the process. The dynamics of airport and community development require the establishment of both a comprehensive and continuing effort to refine plan recommendations, monitor progress, and generally reflect change.

The difficulties and complexities of planning for a combined airport and environs area are substantial. This is especially true where the subject airport is a major air carrier facility

that has been in existence for some time and is required to function well into the future. Fortunately, the Sea-Tac Project was successful enough to serve as a general guide for future efforts of a similar nature.

## REFERENCES

1. Port of Seattle Commission and King County Council, *Sea-Tac Communities Plan* (Seattle: Port of Seattle, 1976).
2. Port of Seattle Commission and King County Council, *Sea-Tac Communities Plan Summary* (Seattle: Port of Seattle, 1976).
3. Port of Seattle Planning and Research Department, *Airborne Traffic of Sea-Tac International Airport and Its Impact On the Economy of King County* (Seattle: Port of Seattle, 1974).
4. Federal Aviation Administration Order 5900.1B, "Planning Grant Program (PGP)," U.S. Department of Transportation, Federal Aviation Administration, 1974 (as amended).
5. Port of Seattle Planning and Research Department, *Element 1.0 Report: Inventory* (Seattle: Port of Seattle, 1973).
6. Speas, R. Dixon & Associates, *Air Transportation System Advance Plan For Puget Sound Governmental Conference*, 1969.
7. "Sea-Tac and Its Neighbors," pamphlet prepared by the League of Women Voters of King County South, August 1973.
8. U.S. Department of Housing and Urban Development, *Noise Abatement and Control: Departmental Policy, Implementation Responsibilities, and Standards* (HUD Circular 1390.2).
9. King County Policy Development Commission, *Report on Community Involvement In the Sea-Tac Communities Planning Process* (Seattle: King County, 1975).
10. MAN-Acoustics & Noise, Inc., *Sea-Tac Communities Plan, Noise Study Final Report, Volume II* (Seattle: Port of Seattle, 1974).
11. Peat, Marwick, Mitchell & Co., *Aviation Demand Forecasts, Sea-Tac Communities Plan* (Seattle: Port of Seattle, 1974).
12. Federal Aviation Regulations, Volume III, Part 36, "Noise Standards: Aircraft Type and Airworthiness Certification," U.S. Department of Transportation, Federal Aviation Administration, December 1, 1969 (as amended).
13. "Noise Insulation Grants Scheme," pamphlet published by the Department of Trade & Industry for the British Airports Authority, 1972.
14. Stevens, Thompson & Runyon, Inc., *Water Quality Analysis* (Seattle: Port of Seattle, 1974).

## References (cont.)

15. Environmental Systems Laboratories, Inc., *Air Quality Analysis* Seattle: Port of Seattle, 1974).
16. King County Land Use Management Division, *Sixth Month Report: Environmental Assessment* (Seattle, Port of Seattle, 1973).