

Final

Natural Resource Mitigation Plan

Master Plan Update Improvements Seattle-Tacoma International Airport



December 2000

Parametrix, Inc.

AR 048591

**NATURAL RESOURCES MITIGATION PLAN
SEATTLE-TACOMA INTERNATIONAL AIRPORT
MASTER PLAN UPDATE IMPROVEMENTS**

Prepared for

PORT OF SEATTLE
Seattle-Tacoma International Airport
P.O. Box 69727
Seattle, Washington 98168-0727

Prepared by

PARAMETRIX, INC.
5808 Lake Washington Blvd. N.E., Suite 200
Kirkland, Washington 98033-7350

December 2000
556-2912-001 (03)

AR 048592

TABLE OF CONTENTS

	<u>Page</u>
EXECUTIVE SUMMARY	xii
1. INTRODUCTION	1-1
1.1 PURPOSE AND NEED FOR THE PROJECT	1-2
1.2 PROJECT LOCATION.....	1-3
1.3 PROJECT DESCRIPTION.....	1-6
1.3.1 Runways and Taxiways	1-10
1.3.2 Runway Safety Area Extensions / South 154 th Street Relocation	1-10
1.3.3 The South Aviation Support Area (SASA)	1-12
1.3.4 On-Site Borrow Source Areas.....	1-12
1.3.5 Other Support Facilities	1-14
1.4 RESPONSIBLE PARTIES	1-14
1.5 DOCUMENT ORGANIZATION	1-14
2. EXISTING CONDITIONS IN THE PROJECT AREA.....	2-1
2.1 WETLANDS	2-1
2.1.1 Wetland Delineation Methodology.....	2-1
2.1.2 Wetland Descriptions	2-7
2.2 STREAMS	2-7
2.2.1 Miller Creek Basin	2-7
2.2.2 Des Moines Creek Basin.....	2-15
2.2.3 Gilliam Creek	2-16
3. NATURAL RESOURCE IMPACTS SUMMARY.....	3-1
3.1 WETLANDS	3-1
3.2 STREAMS.....	3-10
3.3 FLOODPLAINS.....	3-10
3.4 DRAINAGE CHANNELS.....	3-10
3.5 WATER QUANTITY AND WATER QUALITY.....	3-13
4. MITIGATION, MONITORING, MAINTENANCE, AND CONTINGENCY OVERVIEW	4-1
4.1 MITIGATION	4-1
4.1.1 On-Site In-Basin Mitigation.....	4-11
4.1.2 Off-Site Mitigation.....	4-15
4.1.3 Replacement of Functions by the Mitigation Plan.....	4-16
4.2 MONITORING PLAN AND CONTINGENCY MEASURES.....	4-16
4.2.1 Monitoring Approach.....	4-16
4.2.2 Adaptive Management Approach	4-22
5. IN-BASIN MITIGATION PROJECTS	5-1
5.1 VACCA FARM MITIGATION	5-2

TABLE OF CONTENTS
(continued)

		<u>Page</u>
5.1.1	Miller Creek Relocation and Channel Restoration Plan.....	5-3
5.1.2	Vacca Farm Floodplain and Wetland Restoration Plan.....	5-26
5.1.3	Lora Lake Shoreline Enhancement.....	5-43
5.1.4	Implementation of the Vacca Farm Mitigation Projects.....	5-48
5.2	MILLER CREEK RIPARIAN AND INSTREAM ENHANCEMENT PROJECTS	5-58
5.2.1	Miller Creek Riparian Corridor Wetland and Buffer Enhancement Plan ..	5-59
5.2.2	Miller Creek Instream Habitat Enhancement Plan	5-71
5.2.3	Drainage Channel Replacement Plan.....	5-100
5.2.4	Wetland Restoration Plan for Temporary Construction Impacts	5-111
5.2.5	Miller Creek Basin Trust Fund for Watershed Rehabilitation	5-120
5.3	DES MOINES CREEK BASIN RESTORATION PROJECTS	5-124
5.3.1	Mitigation Plans	5-124
5.3.2	Des Moines Creek Basin Trust Fund for Watershed Rehabilitation	5-139
5.3.3	Indirect Impacts to Borrow Area Wetland Hydrology	5-142
6.	HYDROLOGIC IMPACTS AND MITIGATION	6-1
6.1	WATER QUANTITY	6-1
6.1.1	Stormflow Impacts	6-1
6.1.2	Base Flow Impacts	6-16
6.2	WATER QUALITY	6-17
7.	OFF-SITE HABITAT MITIGATION: AUBURN WETLAND MITIGATION	7-1
7.1	GOALS, OBJECTIVES, AND DESIGN CRITERIA	7-2
7.1.1	Goals and Objectives.....	7-5
7.2	WETLAND MITIGATION SITE	7-5
7.2.1	Site Description	7-5
7.2.2	Ownership	7-7
7.2.3	Rationale for Selection.....	7-9
7.2.4	Constraints.....	7-18
7.2.5	Ecological Assessment of the Mitigation Site	7-18
7.3	MITIGATION SITE DESIGN	7-43
7.3.1	Water Regime.....	7-43
7.3.2	Grading.....	7-47
7.3.3	Landscape Plan.....	7-54
7.3.4	Native Plant Communities	7-58
7.4	IMPLEMENTATION	7-67
7.4.1	Pre-construction Meeting.....	7-67
7.4.2	Site Preparation and Planting.....	7-67
7.4.3	Excavation and Grading.....	7-71
7.4.4	Construction Access Roads, Staging Areas, and Maintenance Roads	7-71
7.4.5	Erosion Control	7-72
7.4.6	Irrigation.....	7-73
7.4.7	Establish Native Wetland and Upland Buffer Vegetation.....	7-73
7.4.8	Record Drawings Report and Monitoring	7-73

TABLE OF CONTENTS
(continued)

		<u>Page</u>
	7.4.9 Construction Steps	7-74
7.5	MONITORING AND PERFORMANCE STANDARDS.....	7-77
	7.5.1 Record Drawings and Baseline Monitoring Report	7-77
	7.5.2 10-Year Monitoring Plan	7-78
7.6	SITE PROTECTION.....	7-82
7.7	MAINTENANCE AND CONTINGENCY PLANS	7-82
	7.7.1 Routine Maintenance	7-82
	7.7.2 Contingency Measures.....	7-83
	7.7.3 Performance Standards	7-90
8.	REFERENCES.....	8-1

APPENDICES

A THROUGH E	DESIGN DRAWINGS (UNDER SEPARATE COVER)
F	RESTRICTIVE COVENANTS
G	SEA-TAC THIRD RUNWAY – BORROW AREA 3 PRESERVATION OF WETLANDS
H	SAMPLE DATA SHEETS

LIST OF FIGURES

<u>Figure</u>		<u>Page</u>
1.2-1	Location of Seattle-Tacoma International Airport and Off-Site Wetland Mitigation Site.....	1-4
1.2-2	Locations of Existing Water Features, Stormwater Facilities, Watershed Boundaries, and Acquisition Area of STIA.....	1-5
1.3-1	Proposed Master Plan Update Improvement Projects at STIA	1-11
1.3-2	Existing and Relocated South 154 th /156 th Street	1-13
2.1-1	Wetland Study Area for the Master Plan Update at STIA	2-2
2.1-2	Wetlands in the Miller Creek Basin Near STIA.....	2-8
2.1-3	Wetlands in the Des Moines Creek Basin Near STIA	2-9
2.1-4	Jurisdictional Wetlands at the Vacca Farm Site	2-10
2.2-1	Location of Miller Creek, Walker Creek, and Des Moines Creek Near STIA.....	2-11
2.2-2	Miller Creek 100-year Floodplain	2-13
3.1-1	Wetland Impacts in the Miller Creek Basin Near STIA.....	3-4
3.1-2	Wetland Impacts in the Des Moines Creek Basin Near STIA	3-5
3.1-3	Locations of Potential Temporary Wetland Impacts in the Miller Creek Basin Near STIA	3-7

TABLE OF CONTENTS
(continued)

	<u>Page</u>
5.1-1 Vacca Farm Wetland Restoration Grading Plan.....	5-10
5.1-2 Sediment Transport Velocity vs. Sediment Diameter	5-13
5.1-3 Channel Cross Section Miller Creek Location	5-15
5.1-4 Representative Fish Habitat Enhancement Features.....	5-18
5.1-5 Vacca Farm Planting Plan.....	5-27
5.1-6 Typical Section of Miller Creek Floodplain Enhancement.....	5-29
5.1-7 Typical Planting Plan for Miller Creek Floodplain 1 and 2.	5-39
5.1-8 Typical Cross Section of the Lora Lake Buffer Enhancement.....	5-44
5.2-1 Miller Creek Instream and Buffer Enhancements	5-60
5.2-2 Typical Cross Section of Miller Creek Stream Buffer Enhancement	5-61
5.2-3 Typical Planting Plan for the Miller Creek Upland and Streamside Buffer Planting Zones	5-70
5.2-4 Instream Project 1 Existing Conditions	5-77
5.2-5 Instream Project 2 Existing Conditions	5-78
5.2-6 Instream Project 3 Existing Conditions	5-80
5.2-7 Instream Project 4 Existing Conditions	5-81
5.2-8 Instream Project 1 Proposed Conditions.....	5-83
5.2-9 Instream Project 2 Proposed Conditions.....	5-84
5.2-10 Instream Project 3 Proposed Conditions.....	5-85
5.2-11 Instream Project 4 Proposed Conditions.....	5-86
5.2-12 Representative Cross Sections of Miller Creek Reference Site	5-87
5.2-13 South 156 th Way Bridge Relocation Project.....	5-91
5.2-14 Location of Replacement Drainage Channel and Swales along the West Side of the Third Runway Embankment	5-102
5.2-15 Cross Section A-A' of the Replacement Drainage Channel Drainage Channel, Drainage Collection Swale, and Third Runway Embankment.....	5-104
5.2-16 Cross Section B-B' of the Replacement Drainage Channel, Drainage Collection Swale, and Third Runway Retaining Wall	5-105
5.2-17 Typical Planting Plan for Wetland 37 Restoration	5-115
5.2-18 Typical Planting Plan for Restoration of Temporary Impacts.....	5-116
5.3-1 Location of the Wetland Mitigation Site on the Tyee Valley Golf Course.....	5-125
6.1-1 Miller, Walker, and Des Moines Creek Watersheds	6-2
6.1-2 Detention Facilities for Master Plan Projects	6-9
6.1-3 Flow Duration Curve for Miller Creek at SR509	6-12
6.1-4 Flow Duration Curve for Walker Creek at South 12 th Street	6-13
6.1-5 Flow Duration Curve for Des Moines Creek at South 200 th Street.....	6-14
6.1-6 Flow Duration Curve for Miller Creek at MCDF.....	6-15
7.2-1 Aerial Photograph of the Auburn Wetland Mitigation Site (1999).....	7-6
7.2-2 Wetlands and Groundwater Monitoring Well Locations on the Wetland Mitigation Site ..	7-8

TABLE OF CONTENTS
(continued)

	<u>Page</u>
7.2-3 Potential Mitigation Sites Evaluated in the Miller Creek and Des Moines Creek Watersheds	7-13
7.2-5 Variations in Groundwater (Monitoring Well 1) and Daily Precipitation	7-23
7.2-6 Variation in Groundwater (Monitoring Well 3) and Daily Precipitation	7-24
7.2-7 Variations in Groundwater (Monitoring Well 5) and Daily Precipitation	7-25
7.2-8 Cross Section of Groundwater Elevation (February – August 2000) at the Wetland Mitigation Site	7-26
7.2-9 Groundwater Elevations on the Auburn Wetland Mitigation Site (December 2, 1999)....	7-28
7.2-10 Groundwater Elevations on the Auburn Wetland Mitigation Site (March 8, 2000).....	7-29
7.2-11 Groundwater Elevations on the Auburn Wetland Mitigation Site (June 2, 2000)	7-30
7.2-12 Soil Types on the Proposed Wetland Mitigation Site.....	7-31
7.2-13 Typical Profile at the Wetland Mitigation Site	7-32
7.2-14 Typical Successional Changes in Forested Wetland Vegetation Following Planting	7-41
7.3-1 Relationship of Seasonal Water Level Variations and Soil Surface Elevations to Proposed Wetland Vegetation Classes	7-45
7.3-2 Green River Flood Frequency by Month.....	7-46
7.3-3 Wetland Mitigation Grading Plan.....	7-48
7.3-4 Grading Cross Section for Off-Site Wetland Mitigation.....	7-49
7.3-5 Proposed Wetland Classes and Buffer Vegetation Types for the Wetland Mitigation Site.....	7-55
7.3-6 Proposed Plant Associations for the Wetland Mitigation Site.....	7-56
7.3-7 Typical Planting Plan for the Black Cottonwood Zone and Red Alder Salmonberry Planting Zones	7-59
7.3-8 Typical Planting Plan for the Oregon Ash and Mixed Forest Planting Zone.....	7-61
7.3-9 Typical Planting Plan for the Western Redcedar and the Shrub Planting Zones	7-64
7.3-10 Typical Planting Plan for the Emergent and the Upland Buffer Planting Zones	7-66

LIST OF TABLES

<u>Table</u>	<u>Page</u>
1.3-1 Proposed Master Plan Update improvement projects at Seattle-Tacoma International Airport.	1-6
2.1-1 Summary of wetland and other Waters of the U.S. areas in the Seattle-Tacoma International Airport Master Plan Update Area.	2-3
3.1-1 Summary of wetland impacts for Seattle-Tacoma International Airport Master Plan Update improvements by construction project.....	3-2
3.1-2 Summary of permanent wetland impacts by project and wetland category.....	3-6
3.1-3 Summary of temporary construction impacts to wetlands in the proposed Seattle-Tacoma International Airport Master Plan Update improvement area.	3-6

TABLE OF CONTENTS
(continued)

	<u>Page</u>
4.1-1 Summary of mitigation actions and their relation to National Environmental Policy Act, State Environmental Policy Act, and Clean Water Act mitigation sequencing requirements.	4-2
4.1-2 Summary of compensatory mitigation (on- and off-site) for watershed, wetland, and stream impacts at Seattle-Tacoma International Airport.	4-7
5.1-1 Summary of wetland mitigation areas at Vacca Farm.	5-3
5.1-2 Mitigation goals, design objectives, and design criteria for the Miller Creek relocation project.	5-4
5.1-3 Estimated base flow rates at the Miller Creek detention facility outlet structure.	5-6
5.1-4 Flood frequency estimates for Miller Creek at the Miller Creek detention facility control structure.	5-6
5.1-5 Estimated flow rates for Miller Creek channel design.	5-11
5.1-6 Flood frequency estimates for Miller Creek at the Miller Creek detention facility control structure.	5-11
5.1-7 Final performance standards, evaluation approaches, and contingency measures for mitigation projects at Vacca Farm.	5-21
5.1-8 Miller Creek relocation mitigation monitoring methods and schedule.	5-25
5.1-9 Mitigation goals, design objectives, and design criteria for the Vacca Farm wetland restoration project.	5-30
5.1-10 Groundwater monitoring well data on the Vacca Farm site.	5-32
5.1-11 Proposed seed mix for erosion control.	5-34
5.1-12 Proposed plant list for mitigation projects in Miller and Des Moines Creek basins.	5-37
5.1-13 Monitoring schedule for wetland restoration and floodplain enhancement at Vacca Farm.	5-42
5.1-14 Mitigation design objectives, and design criteria for the buffer enhancement projects at Lora Lake.	5-45
5.1-15 Proposed Implementation Timeline for Vacca Farm Mitigation Projects.	5-49
5.2-1 Mitigation goals, design objectives, and design criteria for the Miller Creek wetland and buffer enhancement project.	5-62
5.2-2 Enhancement planting approach along the Miller Creek buffer.	5-66
5.2-3 Final performance standards, evaluation approach, and contingency measures for wetland and buffer enhancement along Miller Creek.	5-67
5.2-4 Monitoring schedule for the Miller Creek buffer and wetland enhancement project.	5-72
5.2-5 Mitigation goals, design objectives, and design criteria for instream enhancement projects in Miller Creek.	5-73
5.2-6 Summary of existing conditions in Miller Creek between South 156 th Street and Des Moines Memorial Drive.	5-75
5.2-7 Habitat and geomorphic benefits of Miller Creek instream enhancement features.	5-82
5.2-8 Final performance standards, evaluation approach, and contingency measures for instream habitat enhancements in Miller Creek.	5-92
5.2-9 Monitoring schedule for the instream enhancement projects.	5-93

TABLE OF CONTENTS
(continued)

	<u>Page</u>
5.2-10 Proposed Implementation Timeline for Miller Creek In-Stream, Wetland, and Riparian Buffer Enhancements Projects.....	5-96
5.2-11 Mitigation goals, design objectives, and design criteria for replacement drainage channels.	5-101
5.2-12 Final performance standards, evaluation approach, and contingency measures for replacement drainage channels.	5-108
5.2-13 Monitoring schedule for the replacement drainage channels.	5-110
5.2-14 Summary of wetlands subject to temporary construction-related impacts.....	5-112
5.2-15 Mitigation design objectives and criteria for restoration of temporary wetland impacts.	5-112
5.2-16 Final performance standards, evaluation measures, and contingency measures for restoration of temporary wetland impacts.....	5-118
5.2-17 Monitoring schedule for restoration of temporary wetland impacts.	5-119
5.2-18 Potential trust fund projects in the Miller Creek watershed.	5-123
5.3-1 Mitigation goals, design objectives, and design criteria for wetland and buffer enhancement on the Tye Valley Golf Course.	5-126
5.3-2 Final Performance Standards, Evaluation Approach, and Contingency Measures the Tye Valley Golf Course and Des Moines Creek Buffer Mitigation Projects.....	5-133
5.3-3 Monitoring schedule for Des Moines Creek Basin Mitigation Projects.	5-134
5.3-4 Proposed Implementation Timeline for Tye Valley Golf Course and Des Moines Creek Buffer Projects.....	5-136
5.3-5 Summary of potential trust fund projects in the Des Moines Creek watershed.	5-141
5.3-6 Final Performance Standards, Evaluation Approach, and Contingency Measures for Monitoring Borrow Area Wetlands.	5-143
6.1-1 Summary of Miller, Walker, and Des Moines Creek drainage areas at STIA and change in impervious area between 1994 baseline and 2006 future conditions	6-5
6.1-2 Summary of required detention facility volumes.	6-8
6.1-3 Summary of flood peak flow frequency results for Miller/Walker Creek subbasins.....	6-10
6.1-4 Summary of flood peak flow frequency results for Des Moines Creek subbasins	6-11
6.1-5 Estimated Low Stream Flow Changes.....	6-16
7.1-1 Summary of wetland impacts and off-site compensatory design objectives for the proposed Master Plan Update improvements.	7-1
7.1-2 Mitigation goals with associated design objectives and design criteria for the Auburn Mitigation Site.....	7-3
7.2-1 Summary of reported bird strikes at Seattle-Tacoma International Airport (1979-1999)..	7-10
7.2-2 Summary of potential mitigation sites analyzed within the Miller Creek and Des Moines Creek watersheds	7-14
7.2-3 Plant species observed on the mitigation site and adjacent riparian areas during delineation site visits in October 1995 and 2000.	7-19
7.2-4 Wetland indicator status.	7-20
7.2-5 Drainage characteristics of soils occurring on the mitigation site.	7-27

TABLE OF CONTENTS
(continued)

	<u>Page</u>
7.2-6 Wildlife species expected to occur in the Auburn wetland mitigation site after construction.	7-35
7.2-7 Potential wildlife use of constructed wetland habitats.	7-37
7.2-8 Plant species to be planted at the Auburn wetland mitigation site.	7-38
7.3-1 Proposed wetland classes, elevation ranges, and hydrologic regimes.	7-44
7.3-2 Hydroseed mixtures.	7-53
7.3-3 Proposed plant species for the black cottonwood/willow association.	7-60
7.3-4 Proposed plant species list for the red alder/salmonberry association.	7-60
7.3-5 Proposed plant species list for the Oregon ash association.	7-62
7.3-6 Proposed plant species list for the mixed forest association.	7-62
7.3-7 Proposed plant species list for the western redcedar association.	7-63
7.3-8 Proposed plant species list for the willow/red osier dogwood shrub zone.	7-65
7.3-9 Proposed species list for the beaked sedge/water parsley emergent zone.	7-67
7.4-1 Proposed Implementation Timeline for Auburn Wetland Mitigation Projects.	7-68
7.5-1 Auburn Wetland Mitigation Site monitoring methods and schedule.	7-79
7.7-1 Final performance standards, evaluation approach, and contingency measures for the Auburn wetland mitigation project.	7-84

LIST OF ACRONYMS

Abbreviation/ Acronym	Formal Name
ACOE	U. S. Army Corps of Engineers
AMA	Aircraft Movement Area
AOA	Airport Operation Area
ARFF	Airport Rescue and Fire Fighting
ASDE	Airport Surface Detection Equipment
ASR	Airport Surveillance Radar
ASTM	American Society for Testing Materials
BMPs	Best Management Practices
BOD	Biochemical Oxygen Demand
cfs	Cubic feet per second
CWA	Clean Water Act
cy	Cubic yard
DNR	Washington Department of Natural Resources
DO	Dissolved oxygen
Ecology	Washington State Department of Ecology
EIS	Environmental Impact Statement
EPA	U.S. Environmental Protection Agency
ESA	Endangered Species Act
FAA	Federal Aviation Administration
FEIS	Final Environmental Impact Statement
FEMA	Federal Emergency Management Agency
FIRM	Flood Insurance Rate Map
FSEIS	Final Supplemental Environmental Impact Statement
FW	Farmed wetland
GIS	Geographical Information System
HPA	Hydraulic Project Approval
HSPF	Hydrologic Simulation Program—FORTRAN
ILA	Interlocal Agreement
IWS	Industrial Water System
IWTP	Industrial Waste Treatment Plant
JARPA	Joint Aquatic Resource Permit Application

Abbreviation/ Acronym	Formal Name
KCSWM	King County Surface Water Management
LWD	Large woody debris
MSE	Mechanically Stabilized Earth
NAVAIDS	Navigation Aids
NEPA	National Environmental Policy Act
NEPL	North Employees' Parking Lot
NPDES	National Pollutant Discharge Elimination System
NRMP	Natural Resource Mitigation Plan
OHW	Ordinary High Water
OHWM	Ordinary High Water Mark
PGIS	Pollution Generating Impervious Surface
Port	Port of Seattle
RDF	Regional Detention Facility
RM	River Mile
ROW	Right-of-way
RSA	Runway Safety Areas
SASA	South Aviation Support Area
SCS	Soil Conservation Service
SDS	Stormwater Drainage System
SEPA	State Environmental Policy Act
SMP	Stormwater Management Plan
SR	State Route
STEP	South Terminal Expansion Project
STIA	Seattle-Tacoma International Airport
STS	Satellite Transit Shuttle
SWPPP	Stormwater Pollution Prevention Plan
TESC	Temporary Erosion and Sediment Control
USDA-WSD	United States Department of Agriculture-Wildlife Services Division
USFWS	U.S. Fish and Wildlife Service
USGS	U.S. Geologic Survey
VFR	Visual Flight Rule
WAC	Washington Administrative Code

Abbreviation/ Acronym	Formal Name
WDFW	Washington Department of Fish and Wildlife
WHMP	Wildlife Hazard Management Plan
WQC	Water Quality Certification
WQS	Water Quality Standard
WSD	Wildlife Science Division
WSDOT	Washington State Department of Transportation

EXECUTIVE SUMMARY

As currently configured, Seattle-Tacoma International Airport (STIA) is unable to efficiently meet existing and future regional air travel demands. In response to growth forecasts for passenger and cargo volumes at STIA, a variety of facility improvements are planned to meet travel demands in the Puget Sound Region and to reduce the aircraft arrival delays during poor weather. These improvements were developed through a master planning process, then updated to reflect revised growth forecasts for passenger use. Some of the planned improvements will cause unavoidable impacts to wetlands, streams, floodplains, and drainage channels within the project area. This *Natural Resource Mitigation Plan (NRMP)* describes the mitigation actions that the Port of Seattle (Port) will implement to mitigate for unavoidable wetland and stream impacts associated with Master Plan Update improvements.

The STIA Master Plan Update improvements will affect wetlands, streams, floodplain, drainage channels, and stormwater in the Miller and Des Moines Creek basins. To construct the projects, fill material would be placed in approximately 980 linear ft of Miller Creek, approximately 5.24 acre-ft of the Miller Creek 100-year floodplain, approximately 18.37 acres of wetland, and about 1,290 linear ft of drainage channel. In addition, new impervious surfaces will affect stormwater runoff and water quality conditions.

Consistent with federal and state mitigation requirements, this plan describes actions the Port will take to:

- Avoid and minimize impacts to wetlands and streams by reducing impact areas through the use of retaining walls to minimize fill impacts, locate stormwater detention in uplands, and avoid wetlands in borrow areas.
- Restoring temporary impacts to wetlands caused by project construction, including construction stormwater management.
- Compensating for the impact by providing in-kind mitigation that replaces ecological functions lost by filling wetlands and streams.

Compensatory mitigation will restore and enhance ecological and hydrologic functions to over 134 acres of property. About 67 acres of this mitigation occurs on-site, restoring natural wetland and stream conditions to currently developed portions of the Miller and Des Moines Creek basins. Elements of the on-site mitigation will:

- Restore and enhance wetlands riparian to Miller and Des Moines creeks,
- Restore and enhance salmon habitat
- Enhance stream buffers,
- Remove existing land uses that are detrimental to adjacent wetlands and streams,
- Protect water quality and stream hydrology.

An additional 65 acres of mitigation to replace wildlife habitat function will occur at a mitigation site in Auburn, where existing degraded wetlands and abandoned farmland will be restored to a high quality, diverse wetland ecosystem.

A complete description of the goals and objectives of each mitigation project are described in this report. For each mitigation element, an engineering and landscape design is presented and discussed. The NRMP plan also provides detailed performance and monitoring standards, which as permit requirements, will be enforced by permitting agencies to assure that the projects are constructed, evaluated, and adaptively managed. Monitoring and adaptive management will assure that the hydrologic and ecological benefits described in the plan are ultimately achieved.

Overall, the Master Plan Update improvements design and mitigation will protect wetlands and aquatic resources. The substantial mitigation compensates for identified impacts to hydrology (peak flow and low flow), water quality, wetlands (temporary, permanent filling, and indirect), and streams. This mitigation prevents cumulative impacts, attributable to the proposed actions, from occurring.

1. INTRODUCTION

In response to growth forecasts for passenger and cargo volumes at Seattle-Tacoma International Airport (STIA), a variety of facility improvements are planned to meet the air transportation needs of the Puget Sound Region and to reduce the aircraft arrival delays during poor weather. These improvements were developed through a master plan process, then updated to reflect revised growth forecasts for passenger use. Some of the planned improvements will cause unavoidable impacts to wetlands, streams, floodplains, and drainage channels within the project area. This Natural Resource Mitigation Plan (NRMP) describes the mitigation actions that the Port of Seattle (Port) will implement to mitigate for potential unavoidable wetland and stream impacts associated with Master Plan Update improvements. Actions taken to mitigate potential stormwater and water quality impacts due to the proposed projects are summarized in this report (Chapter 6); however, the Stormwater Management Plan (SMP) is described in detail in the *Comprehensive Stormwater Management Plan for Seattle-Tacoma International Airport Master Plan Update Improvements* (Parametrix 2000a). The mitigation plan describes actions that will be implemented upon receipt of, and according to any special conditions of, the Clean Water Act (CWA) Section 404 Permit approval and Section 401 Water Quality Certification (WQC).

The mitigation plan includes two major elements: (1) mitigation actions (described in Chapters 1 through 7 of this document), and (2) detailed plan sheets that graphically depict the mitigation design (included as Appendices A through E of this report). Compensatory mitigation has been proposed to occur on approximately 134 acres, with about 67 acres of on-site mitigation within the Miller and Des Moines Creek basins, and about 65 acres of off-site mitigation at the Auburn mitigation site. Mitigation designs have been revised in response to: (1) comments received on the Public Notice of September 1999 regarding the type and amount of mitigation, and (2) issues raised by the Washington State Department of Ecology (Ecology), the U.S. Fish and Wildlife Service (USFWS), the U.S. Environmental Protection Agency (EPA), the Washington State Department of Fish and Wildlife (WDFW), the City of Auburn, and the U.S. Army Corps of Engineers (ACOE) on previous drafts of the mitigation plan. The plan describes specific actions taken to:

- *Avoid and minimize* impacts to wetlands and streams.
- *Replace wetland functions on-site* to the maximum extent practicable, by restoring and enhancing wetlands in the Miller and Des Moines Creek basins, where compatible with airport operations and where restoration will reduce wildlife attractants near the airport.
- *Enhance and restore stream habitat functions* through buffer restoration and instream habitat enhancement.
- *Restore wetland functions and create new, high quality wetlands off-site* to replace avian habitat functions in compliance with Federal Aviation Administration (FAA) Advisory Circular 150/5200-33.

The mitigation plan includes both in-basin and out-of-basin mitigation projects, and includes the following projects:

In-Basin

- Vacca Farm Restoration: Miller Creek Channel Relocation and Enhancement, Wetland and Floodplain Restoration, and Lora Lake Buffer Enhancement
- Miller Creek Instream Habitat, Wetland, and Riparian Buffer Enhancements
- Restoration of Temporary Construction Impacts
- Replacement of Drainage Channels Adjacent to Miller Creek
- Tyee Valley Golf Course Wetland Mitigation and Des Moines Creek Riparian Buffers
- Trust funds for stream restoration projects

Out-of-Basin

- Wetland Mitigation in Auburn

1.1 PURPOSE AND NEED FOR THE PROJECT

As currently configured, STIA is unable to efficiently meet existing and future regional air travel demands. The airfield operates inefficiently during poor weather because it accommodates aircraft in a single arrival stream only. As a result, significant arrival delay occurs during poor weather. Aircraft are either held on the ground in their originating city, slowed en route, or they are placed in holding patterns to await clearance to land at STIA. These conditions result in inefficient operation of the existing airfield, as described in (FAA 1996,1997a).

With or without airport improvements, airport activity is expected to increase as a result of regional population growth. As aviation demand grows, aircraft operating delay will increase exponentially. The increased passenger, cargo, and aircraft operations demands will place increasing burdens on the existing terminal and support facilities. Without improvements, the roadway system, terminal space, gates, cargo, and freight processing space would become more inefficient and congested, and the quality of service reduced.

While STIA currently has sufficient operation capability during good weather conditions, the existing runway capabilities cause arrival delays during poor weather. For instance, when weather worsens from Visual Flight Rule 1 (VFR 1) to VFR 2, average arrival delay increases by more than ten fold (from 1 minute to 11.4 minutes). Delays further worsen when Instrument Flight Rule (IFR 1/2/3) conditions occur. In these cases, average arrival delay increases more than twenty fold over VFR 1 (from 1 minute to 21.7 minutes). Because these statistics represent averages, some flights experience less delay, while others experience greater delays. The Federal Aviation Administration's (FAA's) National Plan of Integrated Airport Systems concludes that when annual average delays exceed 9 minutes, an airport is experiencing severe delay.

Using average aircraft operating costs developed by the FAA, STIA aircraft delays are estimated to cost the airlines about \$42 million annually under 1992 demand levels. When annual aircraft

operations reach 425,000, delay costs are anticipated to exceed \$176 million annually. Without the third parallel runway, at this level of activity, average VFR 2 arrival delay would exceed 40 minutes and IFR delay would exceed 70 minutes. A third parallel runway, located 2,500 ft west of the existing 16R/34L runway, would permit staggered dual-stream arrivals in poor weather conditions. It would decrease average arrival delays by about 80 percent, as compared to taking no action, and result in a saving of \$132 million per year.

Based on this analysis, and as a result of planning for the Master Plan Update improvements, regional officials have identified the following needs for STIA:

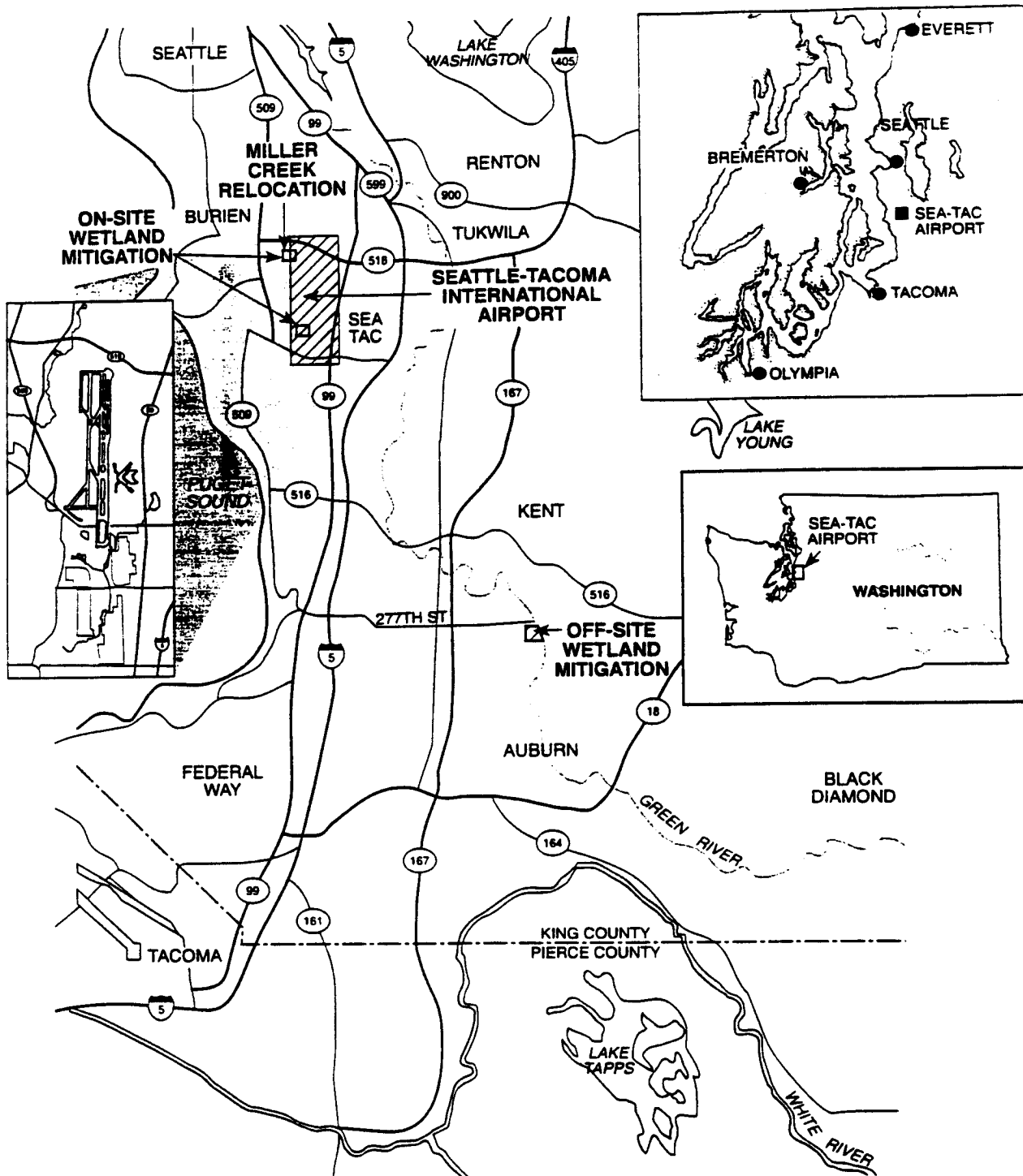
- Improve the poor weather airfield operating capability (over 85 percent of total STIA delays are incurred by aircraft arriving during poor weather).
- Provide sufficient runway length to accommodate warm weather operations and payloads for aircraft types operating to the Pacific Rim.
- Provide Runway Safety Areas (RSAs) that meet FAA standards.
- Provide efficient and flexible land-side facilities to accommodate future aviation demand.

1.2 PROJECT LOCATION

STIA is located within the City of SeaTac in King County, Washington, situated 12 miles south of downtown Seattle (Sections 20, 21, 28, 29, 32, and 33, Township 23N, Range 4E; and Sections 4 and 5, Township 22N, Range 4E, W.M.) (Figure 1.2-1). On-site mitigation projects are located in the vicinity of STIA, while the out-of-basin mitigation project is located southeast of STIA in the City of Auburn, Washington (see Figure 1.2-1).

Mitigation for the Master Plan Update improvements is proposed on land currently owned by the Port within the acquisition area at STIA (Figure 1.2-2), or at the site in Auburn, Washington, which the Port has owned since 1995 (see Figure 1.2-1). The Auburn mitigation site is located on the west side of the Green River and south of South 277th Street (SE¼ Section 31, Township 22N, Range 4E SE, W.M.).

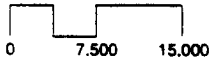
The Port is also proposing to establish two trust funds to be used to support local stream restoration efforts in both the Des Moines and Miller Creek basins. Stream restoration projects may occur on property not owned by the Port.



Port of Seattle/Natural Resource Migration Plan/556-2912-001/01/03) 12/00 (K)

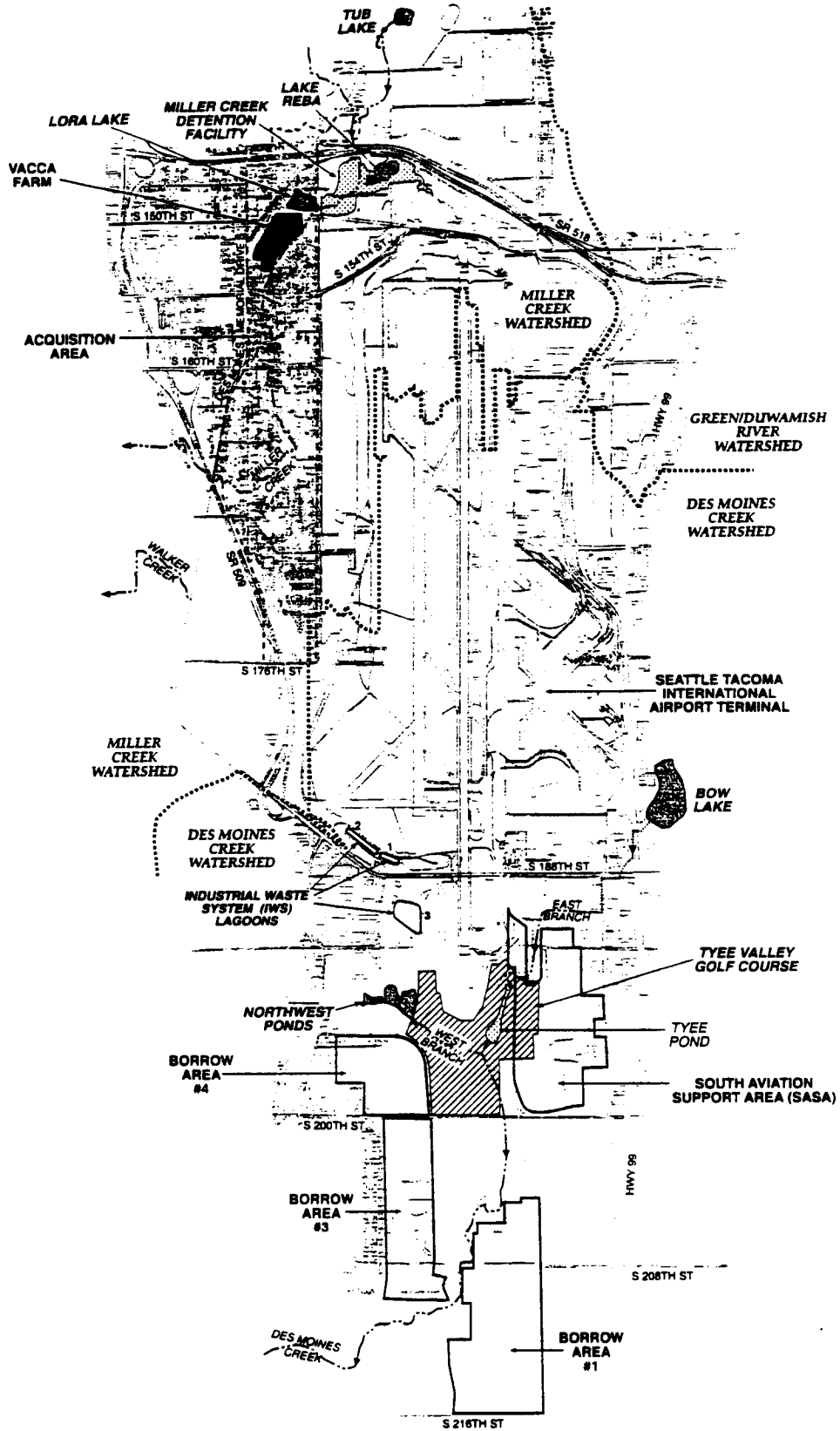


SCALE IN FEET



**Figure 1.2-1
Location of Seattle-Tacoma
International Airport and
Off-Site Wetland Mitigation Site**

AR 048610



Port of Seattle-Natural Resource Mitigation Plan/556-2912-001/0103/ 12/00 (A)

SCALE IN FEET
0 900 1,800



- Approximate Acquisition Area
- Water Features
- Stream
- Current Watershed Boundaries
- Detention Facility
- Tyee Valley Golf Course
- Vacca Farm
- Piped Stream

Figure 1.2-2
Locations of Existing Water Features, Stormwater Facilities, Watershed Boundaries, and Acquisition Area of STIA

1.3 PROJECT DESCRIPTION

The Master Plan Update improvements include construction activities that will fill approximately 18.37 acres of wetlands in the Miller Creek¹ and Des Moines Creek watersheds. Master Plan Update improvements are summarized in Table 1.3-1. Elements of the project that will result in wetland, floodplain, stream, and drainage channel impacts include the following:

- Adding an 8,500-ft-long third parallel runway (16X/34X) with associated taxiway and navigational aids
- Establishing standard RSAs for existing runways 16R/34L and 16L/34R
- Relocating South 154th Street north of extended RSAs and the new third runway
- Developing the South Aviation Support Area (SASA) for cargo and/or maintenance facilities
- Using on-site borrow sources for the third runway embankment
- Relocating, redeveloping, and expanding support facilities (passenger terminal facilities, stormwater facilities [including outfalls], electrical substations, utility corridors, etc.)

These elements of the project are described more fully below.

Table 1.3-1. Proposed Master Plan Update improvement projects at Seattle-Tacoma International Airport.

Project	Description
Runway and Taxiway Projects	
Property Acquisition, Street and Utility Vacation	Includes purchasing property and demolishing existing structures between existing STIA boundary west to Des Moines Memorial Drive and SR 509. Required for third runway embankment fill and construction impact mitigation. Acquisition and demolition is also required for the south runway protection zone (RPZ).
Embankment Fill	Embankment for third runway, constructed using imported fill. Approximately 16.5 million cubic yards (cy) will be placed over a 5- to 7-year period. Existing roads and streets under embankment footprint will be removed.
Interconnecting Taxiways	New connecting taxiways between existing runway and third runway. Project is located on existing airfield, requiring only minimal grading.
Runway 16X/34X	Paving of third runway after completion of embankment fill.
Extension of Runway 34R by 600 ft	Extend runway by 600 ft for improved warm weather and large aircraft operations. Project is located at the southern end of the east runway.
Additional Taxiway Exits on 16L/34R	Construction of new ramps to the existing terminal apron.
Dual Taxiway 34R	Improvements to taxiways serving the SASA area and south apron.
Borrow Sites	
Borrow Sites	Sources of fill for third runway embankment, located on STIA property south of the airport. Approximately 6.7 million cy of material to be excavated from three sites and transported across airport property to the embankment.

¹ References to Miller Creek watershed include Walker Creek.

Table 1.3-1. Proposed Master Plan Update improvement projects at Seattle-Tacoma International Airport (continued).

Project	Description
Runway Safety Areas (RSAs)	
Runway 34R Safety Fill	Extend runway safety fill to meet FAA standards.
RSAs 16R/16L	Extend safety fills by 1,000 ft to meet FAA standards.
Relocation of Displaced Threshold on Runway 16L	Airfield taxiway improvements. The runway threshold (i.e., the emergency landing pad at end of runway pavement) to be relocated onto new RSA.
Miller Creek Sewer Relocation	Relocate sewer for third runway embankment and runway safety fills. New sewer to run along new alignment of South 154 th Street.
FAA Navigation Aids (NAVAIDS)	
New Airport Traffic Control Tower	New air traffic control tower to be located in existing developed area near terminal.
Relocate Airport Surveillance Radar (ASR), Airport Surface Detection Equipment (ASDE), NAVAIDS	Existing radar and navigation equipment will be relocated to allow construction of third runway.
Airfield Building Improvements	
New Snow Equipment Storage	New building to house snow removal equipment.
Weyerhaeuser Hangar Relocation	Relocate existing hangar on west side of airfield to allow construction of third runway. New hangar will be located near south end of third runway.
Terminal/Air Cargo Area Improvements	
Relocation of Airborne Cargo	Relocate existing cargo building from air traffic control tower site to north cargo area. Located in existing developed area near terminal.
Central Terminal Expansion	Passenger terminal remodel. Located in existing developed area at terminal.
South Terminal Expansion Project (STEP)	Passenger terminal remodel. Located in existing developed area to the south of the main passenger terminal.
Northwest Hangar Relocation	Relocate Northwest hangar to site now occupied by Delta hangar. Located in existing developed area.
Satellite Transit Shuttle (STS) System Rehabilitation	Remodel and upgrade underground transit system linking terminal to satellites.
Redevelopment of North Air Cargo	New or expanded air cargo facilities along Air Cargo Road at north end of airport.
Expansion of North Unit Terminal (North Pier)	Addition to new passenger terminal located north of existing terminal. Located in existing developed area (Doug Fox parking lot and airport access freeway).
New Airport Rescue and Fire Fighting Facility (ARFF)	Replaces facility displaced by new North Terminal. The new facility will be located to the north of the North Terminal.
Cargo Warehouse at 24 th Avenue South	New air cargo facility located north of SR 518 on 24 th Avenue South.
Westin Hotel	New hotel located immediately north of main passenger terminal. Located in existing developed area at terminal.
Roads¹	
Temporary SR 518 and SR 509 Interchanges	Temporary access ramps to serve construction of third runway embankment and runway safety fill; to be removed after project completion.

Table 1.3-1. Proposed Master Plan Update improvement projects at Seattle-Tacoma International Airport (continued).

Project	Description
Roads¹ (continued)	
154 th /156 th Street Relocation	Relocate public roadway to allow construction of third runway embankment and runway safety fills. Existing road to be demolished.
154 th /156 th Street Bridge Replacement	Relocate existing South 156 th Street bridge over Miller Creek to accommodate the third runway footprint and South 154 th /156 th Street relocation. In-water work associated with this project is limited to the removal of the existing bridge and bank restoration.
Improvements to Main Terminal Roads	Transportation circulation, seismic and other improvements to roadway systems serving terminal.
Improved Access and Circulation Roadway Improvements	Improvements to existing roadway system serving passenger terminal, garage, and air cargo facilities.
North Unit Terminal Roadways	Improvements to existing roadway system to serve the new North Terminal and garage.
Improvements to South Access Connector Roadway (South Link)	Improvements to existing roadway system serving passenger terminal, garage, and air cargo facilities. Will connect terminal and garage area to South Access roadway and SR 509 extension south of airport.
Parking	
Main Parking Garage Expansion	Expand parking facility at main passenger terminal on north and south sides (existing developed areas), and add floors to portions of existing garage.
The North Employees Parking Lot (NEPL), Phase 1	New parking facility for employees, located north of SR 518.
North Unit Parking Structure	Construction of new garage serving new North Terminal facility. Facility will be located at existing Doug Fox parking lot.
The South Aviation Support Area (SASA)	
The SASA and Access Taxiways	New airport support facility for cargo and/or maintenance, located at the south end of the airport south of the Olympic Tank Farm and South 188 th Street. Airplane access will be by new parallel taxiway constructed along Runway 34R.
Relocation of Existing Facilities to the SASA	Airport operation support facilities will be relocated to the SASA once SASA site development is completed. Many of these facilities must be relocated from their present locations due to main terminal expansion (i.e., STEP and North Terminal), including Northwest hangar, ground support equipment, ground and corporate aviation facilities, new airport maintenance building, and United maintenance complex.
Stormwater Facilities²	
SASA Detention Pond	Create regional stormwater detention pond for the SASA project and other sites. Pond is 33.4 acre-ft and discharges to Des Moines Creek.
NEPL Vault	A 13.9 acre-ft vault to retrofit the NEPL; discharges to Miller Creek via Lake Reba.
Third Runway Vaults and Ponds	Stormwater detention vaults and ponds at the north, west, and south sides of the airport, discharging to Miller, Walker, and Des Moines Creeks.
STIA Retrofit Facilities	Detention vaults or ponds to provide flow control retrofitting for existing STIA discharges to Des Moines Creek. Vaults to be constructed in combination with third runway facilities when possible.
Cargo Vault	Detention vault for North Cargo Facility (4.5 acre-ft discharging to Miller Creek via Lake Reba).

Table 1.3-1. Proposed Master Plan Update improvement projects at Seattle-Tacoma International Airport (continued).

Project	Description
Natural Resources	
Miller Creek Relocation	Approximately 980 ft of Miller Creek immediately downstream of the Miller Creek Detention Facility will be relocated to accommodate third runway embankment and runway safety fill.
Miller Creek Buffer and Wetland Enhancement	Establish a 100-ft buffer (average) along approximately 6,500 linear ft of Miller Creek and riparian wetlands associated with Miller Creek within the acquisition area. Enhance approximately 7.4 acres of existing wetlands along the stream.
Miller Creek Floodplain and Wetland Restoration	Excavate approximately 9,600 cy from the Vacca Farm site adjacent to Miller Creek to compensate for approximately 8,500 cy of floodplain fill for third runway embankment and north safety fill. Restore and enhance approximately 17 acres of stream habitat, floodplain wetlands, aquatic habitat in Lora Lake, and buffers at Vacca Farm.
Miller Creek Instream Habitat Enhancement	<p>Project 1: South of the Vacca Farm site, approximately 235 ft of channel. Remove rock riprap, footbridges, and trash. Place large woody debris (LWD) throughout this section of the stream. Plant riparian areas along the stream with native wetland and upland plant species.</p> <p>Project 2: Approximately 150 ft upstream of South 160th Street, approximately 235 ft of channel. Install LWD in the stream channel, grade a small section of the west bank of the stream to create a gravel bench in the floodplain, remove two rock weirs to improve fish passage, and plant the upland area with native trees and shrubs.</p> <p>Project 3: Immediately downstream of South 160th Street, approximately 380 ft of channel. Grade a section of the east bank, remove a rubber-tire bulkhead and install LWD in the stream and on its banks. Plant buffer areas with native trees and shrubs.</p> <p>Project 4: Miller Creek immediately upstream of 8th Avenue South, approximately 420 ft of channel. Grade portions of both banks. Remove footbridges and portions of concrete block walls. Install LWD in the stream and on its banks. Plant buffer areas with native trees and shrubs.</p> <p>In addition to these specific enhancements, debris such as tires, garbage, and fences will be removed throughout the entire stretch of Miller Creek from the Vacca Farm site south to Des Moines Memorial Drive. In areas where access is readily available, LWD will be selectively placed throughout the stream to improve instream habitat conditions.</p>
Drainage Channels Relocation	Relocate a minimum of 1,290 linear ft of drainage channels to accommodate the third runway embankment. Plant buffers along the drainage channels with native grass and shrubs.
Restoration of Temporarily Impacted Wetlands	Approximately 2.05 acres of wetland located west of the third runway embankment, north of relocated South 154 th Street, and west of the Miller Creek relocation project, will be temporarily filled or disturbed during embankment construction. When construction activities are completed, remove fill material, restore pre-disturbance topography, and plant wetlands with native shrub vegetation.
Tyee Valley Golf Course Wetlands Enhancement and Des Moines Creek Buffer Enhancement	<p>Restore approximately 4.5 acres of emergent wetland area and approximately 1.6 acres of buffer located within Tyee Valley Golf Course to a native shrub vegetation community. The enhancement actions would be integrated into plans to construct a Regional Detention Facility (RDF) on the golf course (King County Capital Improvement Project Design Team 1999). The enhancement would convert the existing turf wetland to native shrub wetland community.</p> <p>Enhance approximately 3.4 acres (average 100 ft wide) of buffer and 1.0 acre of existing wetland along Des Moines Creek.</p>

Table 1.3-1. Proposed Master Plan Update improvement projects at Seattle-Tacoma International Airport (continued).

Project	Description
Wetland Habitat (including Avian Habitat) near the Green River in Auburn	Restore wetland functions to a 67-acre parcel near the Green River in the City of Auburn. Create and/or restore approximately 17.2 acres of forest, 6.0 acres of shrub, 6.2 acres of emergent, and 0.60 acre of open-water wetland. Enhance protective buffers totaling about 15.90 acres.

- ¹ Temporary roads used to haul fill material from three on-site borrow areas to construction sites are included in the analysis of the borrow areas and not listed here.
- ² Des Moines Creek Basin Plan Committee will construct a Regional Detention Facility (RDF) on Tyee Golf Course to provide regional flow control. This project would eliminate the need for STIA retrofit facilities described above. As this is a cumulative action subject to future federal action, it is not a Master Plan Update improvement.

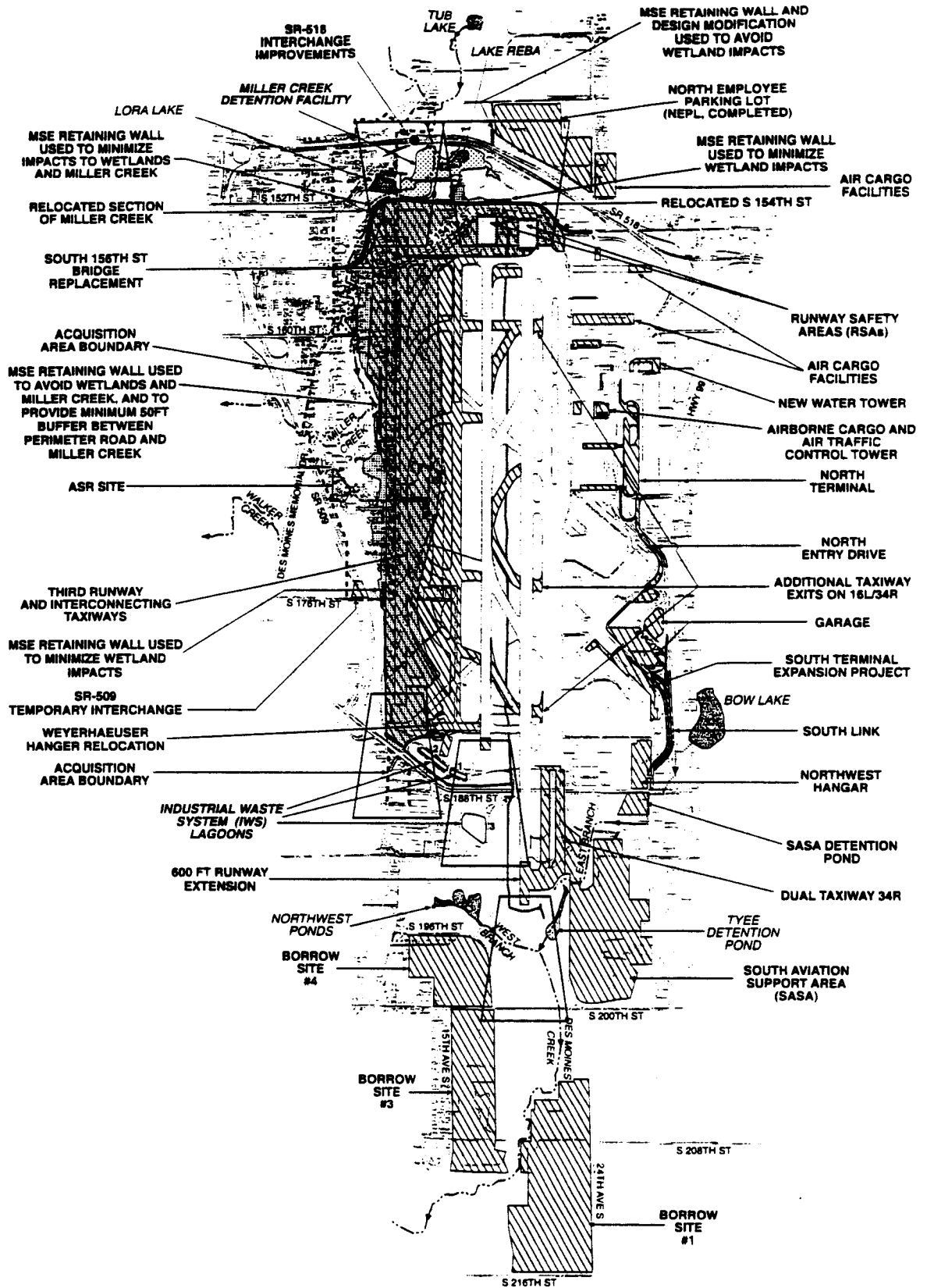
1.3.1 Runways and Taxiways

To overcome aircraft arrival congestion during poor weather conditions, the Port proposes to build a new 8,500-ft runway on approximately 16.5 million cubic yards (cy) of fill on the west side of the existing STIA airfield (Figure 1.3-1). The existing airfield plateau will be extended west over 12th Avenue South. The current location of 12th Avenue South will be the approximate centerline of the new runway. To construct the third runway and extend the airfield plateau, a large embankment with four mechanically stabilized earth (MSE) retaining walls will be constructed. The MSE retaining walls are located at the northern, central, and southern portions of the embankment (see Figure 1.3-1), and have been designed to avoid and minimize direct impacts from the embankment to Miller Creek and associated wetlands. Security and emergency access roads will be constructed around the runway perimeter. New and relocated interconnecting taxiways will also be constructed.

To accommodate the third runway embankment, stormwater management facilities, and a neighborhood noise abatement area, the Port has purchased land west of the existing runway. Most of this land consists of private residences. In this report, this area is referred to as the “acquisition area.” The acquisition area is generally bounded by State Route (SR) 518 to the north, South 176th Street to the south, Des Moines Memorial Drive to the west, and 12th Avenue South to the east (see Figure 1.3-1). Several parcels in and adjacent to the acquisition area are voluntary acquisitions and may or may not be acquired by the Port. However, no additional action, other than demolitions, will be taken in the voluntary acquisition areas. At the north end of the third runway, South 154th Street would be relocated to accommodate the new runway (see below).

1.3.2 Runway Safety Area Extensions / South 154th Street Relocation

RSA extensions are necessary for the existing runways and the new third runway to ensure that they meet current FAA standards. The RSA extensions are to be created at the north end of the existing airport runways south of SR 518, and at the southern end of the new third runway. The RSA extensions at the north end of the two existing runways, as well as the new third runway construction, will require relocating South 154th Street (Figure 1.3-2). The relocated road section will be located approximately 55 to 650 ft north of the current alignment. The new alignment will be north and west of the third runway embankment, connecting with South 156th Street at Des Moines Memorial Drive. In addition, a portion of an existing sewer line will be relocated to parallel the new road alignment.



Part of State/Nature Resource Integration Plan 564-2012-001/01(03) 12/00 (4)

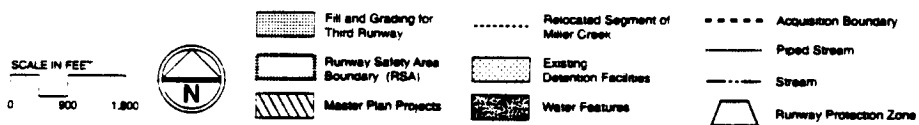


Figure 1.3-1
Master Plan Update
Improvement Projects
at STIA

AR 048617

South 156th Street currently crosses over Miller Creek on an existing timber bridge. The existing bridge will be replaced with a new bridge that spans the stream and floodplain of Miller Creek as part of the South 154th Street relocation (see Figure 1.3-2).

An MSE retaining wall will be constructed along the north side of the relocated road to minimize filling of the forested wetlands located north of the roadway (see Figure 1.3-2). The MSE wall at this location will extend up to approximately 50 ft in height.

1.3.3 The South Aviation Support Area (SASA)

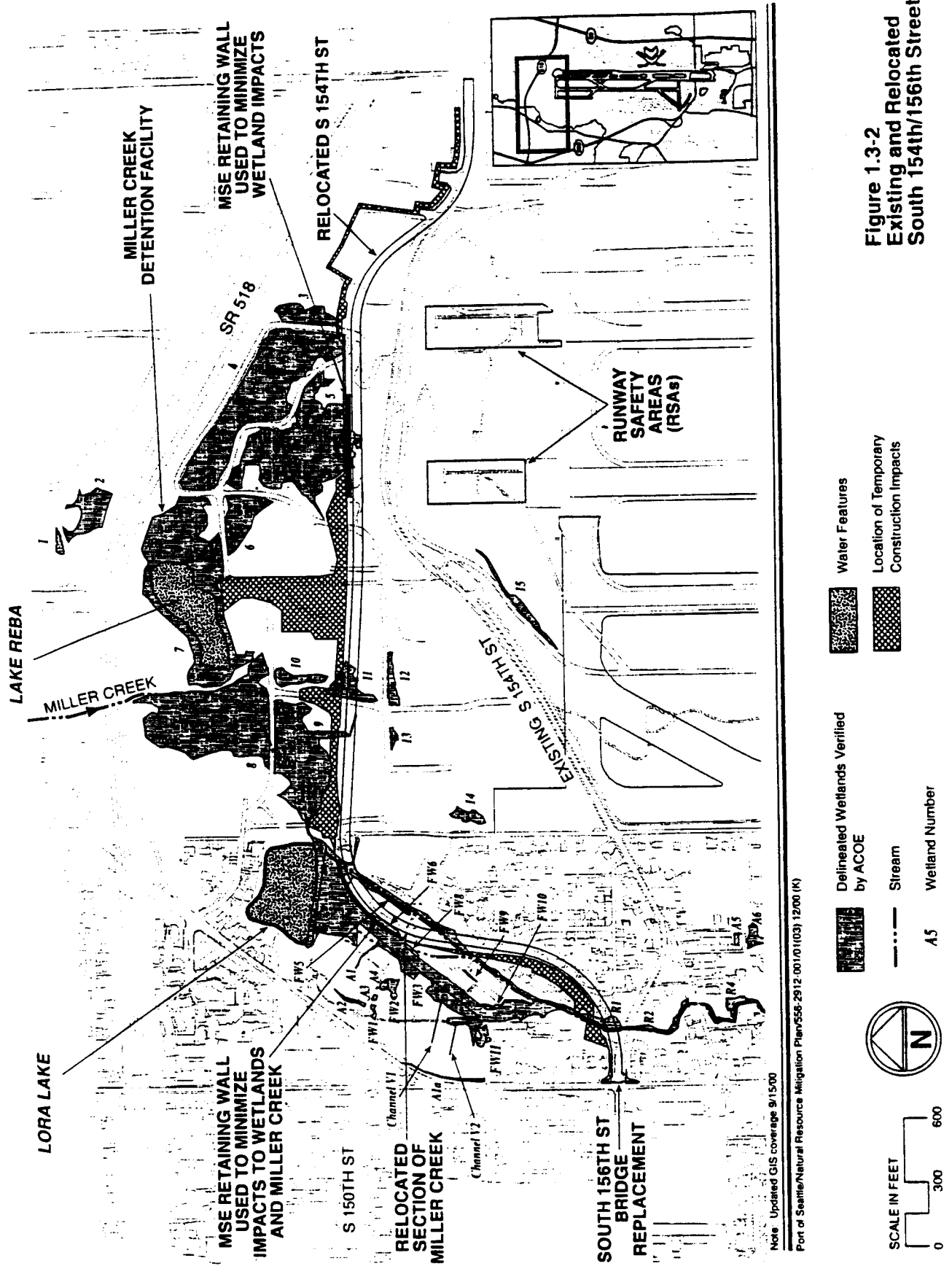
The SASA (see Figure 1.3-1) will provide space for aircraft maintenance/support and air cargo facilities. The FEIS for the Master Plan Update improvements identified several existing uses that would be moved to the SASA, primarily due to the expansion of the Main Terminal. These uses include Northwest Airlines aircraft maintenance and hangar, the U.S. Post Office airmail facility, and possibly Airborne cargo. The SASA will also allow for the expansion of air cargo and aircraft maintenance requirements of airlines and other tenants. The SASA facility will accommodate:

- Relocated line maintenance and cargo facilities that must be moved prior to the expansion of passenger terminal facilities
- Line maintenance requirements
- Aircraft maintenance facilities in response to existing and/or future market demands
- Expansion of cargo handling and maintenance capabilities
- Other aircraft support facilities

1.3.4 On-Site Borrow Source Areas

On-site borrow areas are proposed to be excavated as a source of fill to be used to construct portions of the runway embankment. Three on-site borrow areas are located on airport property between 24th Avenue South and 15th Avenue South, and between South 196th and South 216th Streets (see Figure 1.3-1). These borrow areas are planned to supply approximately 6.7 million cy of fill material. Current engineering estimates suggest that Borrow Site 1 will supply up to 4.2 million cy, and Borrow Sites 3 and 4 will supply 2.5 million cy.

An additional 2.4 million cy is available from on-site sources within the third runway footprint. This fill material will be obtained through excavation at the south end of the third runway, where materials are stockpiled and where the existing ground elevation is above the final grade for the runway. The fill material from these sources has been tested for structural integrity and found to be suitable for use in the RSAs and portions of the infield.



Note: Updated GIS coverage 9/15/00
 Part of Seattle/Natural Resource Mitigation Plan 556-2912-0010(103) 12/00 (K)

1.3.5 Other Support Facilities

Stormwater, electrical, water, sewer, and other utilities must be provided to new or reconstructed airport facilities. Utilities that will result in unavoidable wetland impacts include the placement of stormwater detention facilities for the runway embankment, relocation of a sewer line, and the SASA detention pond. These wetland impacts are discussed in more detail in Chapter 3 of this report, and in the *Wetland Functional Assessment and Impact Analysis* (Parametrix 2000b).

1.4 RESPONSIBLE PARTIES

The Port is the applicant and owner of this project. The name and phone number of the Port representative in charge of environmental permitting and compliance for the project is: Ms. Elizabeth Leavitt, Manager-Aviation Environmental Programs; Port of Seattle; P.O. Box 68727; Seattle, WA 98168-0727; (206) 433-7203.

1.5 DOCUMENT ORGANIZATION

The organization of this document is based on the *Guidelines for Developing Freshwater Wetlands Mitigation Plans and Proposals* (Ecology 1994a). Following the introduction to the project and mitigation actions in Chapter 1, Chapter 2 describes existing ecological conditions, and in particular, existing conditions of wetlands and streams within the project area. Chapter 3 summarizes the direct and indirect impacts of the project to wetlands and other Waters of the U.S. (described in detail in Parametrix 2000b).

Chapter 4 provides a summary of the mitigation and performance monitoring plan. The mitigation sequencing approach and specific mitigation projects are described. The overall monitoring approach, methods, and schedules required to assure the ecological benefits of the mitigation is summarized. A description of the adaptive management approach that will be used to implement maintenance and contingency measures at the mitigation sites is also provided. Chapter 4 also describes the integrated weed management strategy that will be used to control invasive non-native species. Finally, Chapter 4 summarizes the relationship between the *Wildlife Hazard Management Plan* (WHMP) for controlling wildlife hazards near the airport, and each mitigation project.

Chapter 5 provides detailed mitigation plans, performance standards, monitoring approach, and implementation schedules for the on-site mitigation in the Miller and Des Moines Creek basins. Chapter 5 also describes mitigation to replace functions of drainage channels, mitigation for temporary construction impacts, and the monitoring of wetlands adjacent to the construction projects.

The stormwater management plan that is proposed to avoid, minimize, and mitigate for impacts to water quantity and/or quality in Miller and Des Moines Creeks is described in Chapter 6. Chapter 7 describes the mitigation plans, performance standards, monitoring approach, and schedules for the off-site wetland mitigation in Auburn.

Appendices A through E provide detailed plan drawings of key elements of each mitigation project. Appendix F includes the restrictive covenant language for mitigation sites. Appendix G contains the report on indirect hydrology impacts and mitigation at Borrow Area 3 produced by Hart Crowser (Hart Crowser 2000e). Appendix H includes samples of data sheets that would be used collecting information on wetlands during the monitoring period.

2. EXISTING CONDITIONS IN THE PROJECT AREA

This chapter describes the wetlands, streams, floodplains, and drainage channels in areas that will be temporarily or permanently impacted as a result of Master Plan Update improvements. The wetlands within the project area are described in detail in the *Wetland Delineation Report for Seattle-Tacoma International Airport Master Plan Update Improvements* (Parametrix 2000c), and the *Wetland Functional Assessment and Impact Analysis Report* (Parametrix 2000b). Additional detailed information on species listed under the Endangered Species Act is provided in the *Biological Assessment* (FAA 2000). Detailed information on existing ecological conditions relevant to the mitigation design at each site is included with the descriptions of each mitigation project in Chapters 5 and 7.

2.1 WETLANDS

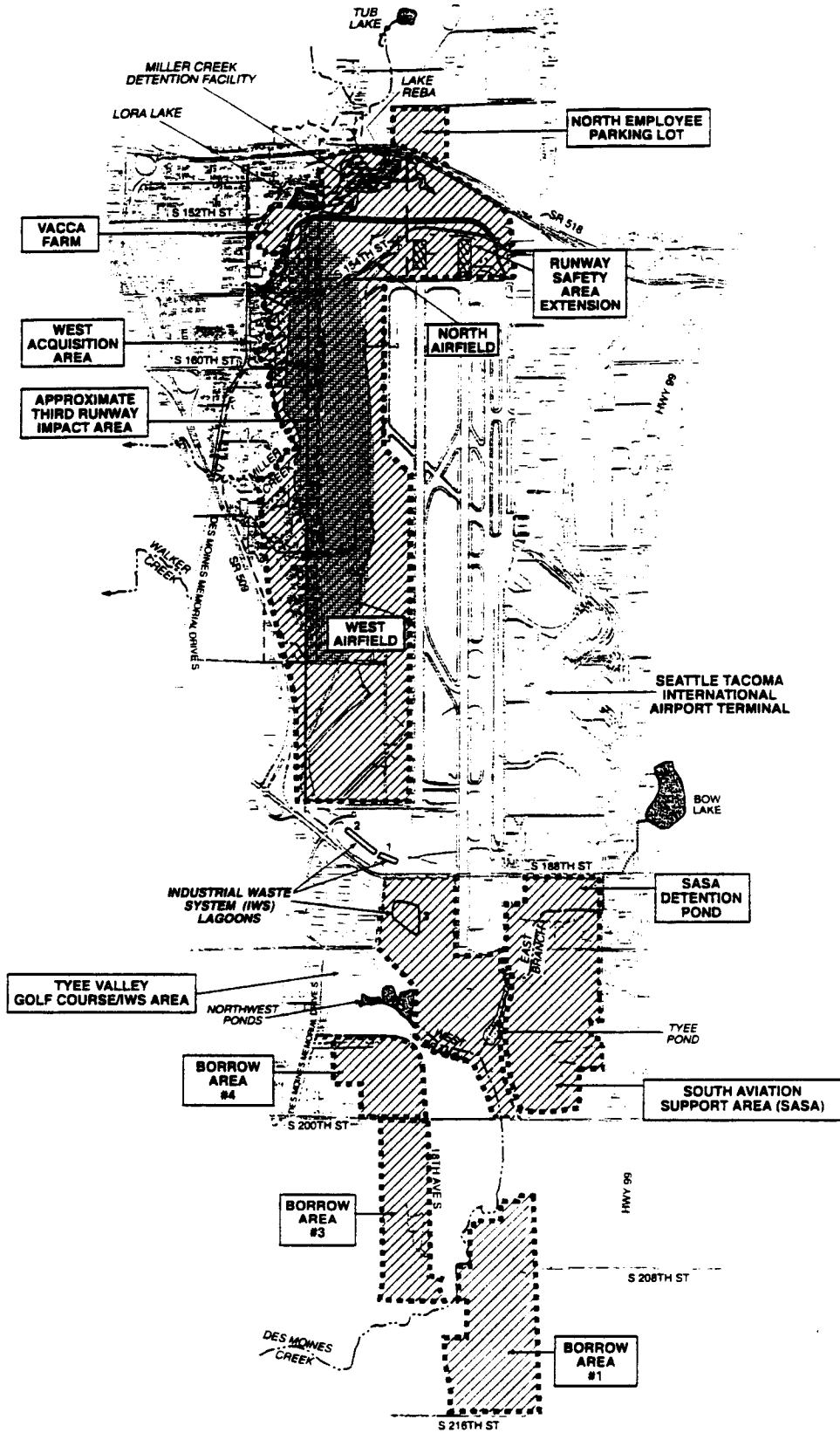
Wetland delineations have been completed throughout the project area (FAA 1996; Parametrix 2000c). ACOE has verified the wetland delineations on all properties within the acquisition area, with the exception of parcels containing Wetland A20.

2.1.1 Wetland Delineation Methodology

Parametrix staff completed field investigations to identify and delineate wetlands in the acquisition area between March 1998 and November 2000. During these site visits, they inspected the project area (Figure 2.1-1) for wetland characteristics and related drainage features. Project staff identified and delineated wetlands in the project area using the Routine Determination Method outlined in the *Washington State Wetland Identification and Delineation Manual* (Ecology 1997) and the *U.S. Army Corps of Engineers Wetland Delineation Manual* (Environmental Laboratory 1987). The delineation methodology incorporated the following regulatory guidance letters and memoranda: ACOE Regulatory Guidance Letters 82-2, 86-9, and 90-7 (ACOE 1982, 1986, 1990); 3-92 Memorandum (ACOE 1992); 5-94 Public Notice (ACOE 1994); Ecology, 3/95 Public Notice (Ecology 1995).

To be considered a wetland, under normal circumstances, an area must have hydrophytic (wetland) vegetation, hydric soils, and wetland hydrology (Ecology 1997; Environmental Laboratory 1987). Areas that do not exhibit indicators for one or more of these three parameters are generally not regulated wetlands. However, in some cases when normal circumstances do not hold, all three parameters may not be present. Additional evaluations were completed to identify wetlands in disturbed and farmed areas (Parametrix 2000c).

ACOE made site visits to confirm wetland identifications and boundary delineations between July 1998 and November 2000. Modifications to delineated wetland boundaries that were requested by ACOE during those site visits have been made and are reflected in the mapping and analysis presented in this report. A summary of all the wetlands identified in the study area is presented in Table 2.1-1.



Port of Seattle Natural Resource Management Plan 556-2912-001(01)(02) 12/00 (R)



Figure 2.1-1
Wetland Study Area for the
Master Plan Update at STIA

AR 048623

Table 2.1-1. Summary of wetland and other Waters of the U.S. areas in the Seattle-Tacoma International Airport Master Plan Update Area.

Wetland ¹	Classification ²	Area (Acres)	Drainage Basin
North Employee Parking Lot Area			
1	Forest	0.07	Miller
2	Forest	0.73	Miller
	Subtotal	0.80	
Runway Safety Area Extension			
3	Forest	0.56	Miller
4	Forest	5.00	Miller
5	Forest/Scrub-Shrub	4.63	Miller
6	Scrub-Shrub	0.86	Miller
	Subtotal	11.05	
Third Runway Project Area			
North Airfield			
7 ³	Forest/Open Water/Emergent	6.68	Miller
8	Scrub-Shrub/Emergent	4.95	Miller
9	Forest/ Emergent (40/60)	2.83	Miller
10	Scrub-Shrub	0.31	Miller
11	Forest/Emergent (80/20)	0.50	Miller
12	Forest/Emergent (20/80)	0.21	Miller
13	Emergent	0.05	Miller
14	Forest	0.19	Miller
West Airfield			
15	Emergent	0.28	Miller
16	Emergent	0.05	Miller
17	Emergent	0.02	Miller
18	Forest/Scrub-Shrub/Emergent (50/20/30)	3.56	Miller
19	Forest	0.56	Miller
20	Scrub-Shrub/Emergent (90/10)	0.57	Miller
21	Forest	0.22	Miller
22	Scrub-Shrub/Emergent (90/10)	0.06	Miller
23	Emergent	0.77	Miller
24	Emergent	0.14	Miller
25	Forest	0.06	Miller
26	Emergent	0.02	Miller
W1	Emergent	0.10	Miller
W2	Forest/Emergent (20/80)	0.22	Miller
	Other Waters of the U.S.	0.02	Miller
Vacca Farm Site			
FW1	Farmed Wetland	0.03	Miller
FW2	Farmed Wetland	0.09	Miller

Table 2.1-1. Summary of wetland and other Waters of the U.S. areas in the Seattle-Tacoma International Airport Master Plan Update Area (continued).

Wetland ¹	Classification ²	Area (Acres)	Drainage Basin
FW3	Farmed Wetland	0.59	Miller
FW5	Farmed Wetland	0.08	Miller
FW6	Farmed Wetland	0.07	Miller
FW8	Farmed Wetland	0.03	Miller
FW9	Farmed Wetland	0.01	Miller
FW10	Farmed Wetland	0.02	Miller
FW11	Farmed Wetland	0.11	Miller
	Other Waters of the U.S.	0.02	Miller
West Acquisition Area			
35a-d	Forest/Emergent (40/60)	0.67	Miller
37a-f	Forest/Emergent (70/30)	5.73	Miller
39	Forest/Scrub-Shrub/Emergent (25/50/25)	0.90	Miller
40	Scrub-Shrub	0.03	Miller
41a and b	Emergent/Open Water	0.44	Miller
44a and b	Forest/Scrub-Shrub (70/30)	3.08	Miller
A1	Forest/Scrub-Shrub/Emergent (15/15/70)	4.66	Miller
A2	Scrub-Shrub	0.05	Miller
A3	Scrub-Shrub	0.01	Miller
A4	Scrub-Shrub	0.03	Miller
A5	Emergent	0.03	Miller
A6	Forest	0.16	Miller
A7	Forest	0.30	Miller
A8	Forest/Scrub-Shrub (30/70)	0.38	Miller
A9	Scrub-Shrub	0.04	Miller
A10	Scrub-Shrub	0.01	Miller
A11	Scrub-Shrub	0.02	Miller
A12	Scrub-Shrub	0.11	Miller
A13	Forest	0.12	Miller
A14a and b	Forest/Scrub-Shrub/Emergent (50/25/25)	0.19	Miller
A15	Emergent	0.04	Miller
A16	Scrub-Shrub/Emergent (20/80)	0.09	Miller
A17	Forest/Scrub-Shrub/Emergent (20/80)	2.66	Miller
A18	Scrub-Shrub	0.01	Miller
A19	Emergent	0.04	Miller
Lora Lake	Open Water	3.06	Miller
	Other Waters of the U.S.	0.33	Miller
Riparian Wetlands			
R1	Emergent	0.17	Miller
R2	Scrub-Shrub/Emergent (70/30)	0.12	Miller
R3	Scrub-Shrub	0.02	Miller
R4	Emergent	0.11	Miller
R4b	Forest/Emergent (25/75)	0.11	Miller

Table 2.1-1. Summary of wetland and other Waters of the U.S. areas in the Seattle-Tacoma International Airport Master Plan Update Area (continued).

Wetland ¹	Classification ²	Area (Acres)	Drainage Basin
R5	Emergent	0.05	Miller
R5b	Forest/Emergent (25/75)	0.07	Miller
R6	Forest/Emergent (25/75)	0.21	Miller
R6b	Emergent	0.09	Miller
R7	Forest/Emergent (25/75)	0.04	Miller
R7a	Emergent	0.04	Miller
R8	Scrub-Shrub/Emergent (40/60)	0.40	Miller
R9	Forest	0.38	Miller
R9a	Forest/Scrub-Shrub/Emergent (25/50/25)	0.74	Miller
R10	Scrub-Shrub	0.04	Miller
R11	Emergent	0.42	Miller
R12	Forest	0.03	Miller
R13	Emergent	0.12	Miller
R14a	Scrub-Shrub/Emergent (25/27)	0.13	Miller
R14b	Emergent	0.08	Miller
R15a	Forest/Scrub-Shrub/Emergent (25/65/10)	0.79	Miller
R15b	Forest/Emergent (25/75)	0.25	Miller
R17	Forest	0.31	Miller
	Subtotal	51.33	
Borrow Area 1			
32	Emergent	0.09	Des Moines
48	Forest/Emergent (20/80)	1.58	Des Moines
B1	Forest/Scrub-Shrub (30/70)	0.27	Des Moines
B4	Scrub-Shrub	0.07	Des Moines
B11	Emergent	0.18	Des Moines
B12 ⁴	Scrub-Shrub	0.63	Des Moines
B14	Scrub-Shrub/Emergent (70/30)	0.78	Des Moines
B15 a and b ⁴	Scrub-Shrub	2.05	Des Moines
	Other Waters of U.S.	0.01	Des Moines
	Subtotal	5.66	
Borrow Area 3			
29	Forest	0.74	Des Moines
30	Forest/Scrub-Shrub (80/20)	0.88	Des Moines
B5	Forest/Scrub-Shrub (40/60)	0.08	Des Moines
B6	Forest/Scrub-Shrub (30/70)	0.55	Des Moines
B7	Forest/Scrub-Shrub (30/70)	0.03	Des Moines
B9	Forest	0.05	Des Moines
B10	Forest	0.02	Des Moines
	Subtotal	2.35	

Table 2.1-1. Summary of wetland and other Waters of the U.S. areas in the Seattle-Tacoma International Airport Master Plan Update Area (continued).

Wetland ¹	Classification ²	Area (Acres)	Drainage Basin
South Aviation Support Area (SASA)/Tyee Valley Golf Course			
28 ⁴	Scrub-Shrub/Emergent/Open Water (50/30/20)	35.45	Des Moines
52	Forest/Scrub-Shrub/Emergent (80/20/20)	4.70	Des Moines
53	Forest	0.60	Des Moines
G1	Emergent	0.05	Des Moines
G2	Emergent	0.02	Des Moines
G3	Emergent	0.06	Des Moines
G4	Emergent	0.04	Des Moines
G5	Emergent	0.87	Des Moines
G6	Emergent	0.01	Des Moines
G7	Forest/Scrub-Shrub (30/70)	0.50	Des Moines
G8	Emergent	0.04	Des Moines
WH	Open Water	0.25	Des Moines
DMC	Forest/Scrub-Shrub/Emergent	1.08	Des Moines
	Subtotal	43.67	
IWS Area			
IWS a and b	Forest	0.67	Des Moines
	Subtotal	0.67	
South Aviation Support Area Detention Pond			
E1	Forest	0.23	Des Moines
E2	Forest	0.04	Des Moines
E3	Forest	0.06	Des Moines
	Subtotal	0.33	Des Moines
TOTAL		115.86	

¹ Wetlands are labeled according to the following protocol:

- Wetlands with only numerical designations (e.g., Wetland 35 or Wetland 44) were described by Shapiro and Associates, Inc. (FAA 1995).
- Wetlands with an 'A' designation (e.g., Wetland A5 or A10) are wetlands occurring within the west acquisition area.
- Wetlands with an 'R' designation (e.g., Wetland R5 or R6) are riparian wetlands occurring within the west acquisition area.
- Wetlands with a 'W' designation (e.g., Wetland W1 or W2) are wetlands occurring within the west airfield area.
- Wetlands with a 'G' designation (e.g., Wetland G5 or G6) are wetlands occurring within the Tyee Valley Golf Course or the SASA areas.
- Wetlands with an 'E' designation (e.g., Wetland E1 or E2) are wetlands occurring within the SASA detention pond area.
- Wetlands with an 'IWS' designation (e.g., IWSa and IWSb) are wetlands occurring near the IWS lagoon.
- Wetlands with a 'B' designation (e.g., Wetland B5 or B10) are wetlands occurring within the borrow sites.
- Wetland numbers followed by a small case letter designate subsections of a larger wetland (i.e., Wetland 35a, or 35b) where constructed features (i.e., driveways) fragment a larger wetland.

² Numbers indicate approximate percentage of cover by respective wetland classes (Cowardin et al. 1979).

³ Includes Lake Reba.

⁴ Portions of the wetland area are estimated.

2.1.2 Wetland Descriptions

About one hundred seventeen wetlands totaling about 115 acres were identified within the study area in the Miller and Des Moines Creek basins (see Table 2.1-1; Figures 2.1-2, 2.1-3, and 2.1-4). These wetlands range in size from 0.01 to about 35 acres (see Table 2.1-1), and include slope, depression, and riparian wetlands (Brinson 1993). Palustrine forested, scrub-shrub, emergent, and open-water wetland classes are present within the project area (see Table 2.1-1). A detailed description of all wetlands found within the study area is provided in the *Wetlands Delineation Report* (Parametrix 2000c). Many of the wetlands in the project area are small, degraded by past and ongoing human disturbance, and isolated from other wetlands by areas of unsuitable habitat (e.g., roadways, buildings). Ecological functions of wetlands within the study area are described in the *Wetland Functional Assessment and Impact Analysis Report* (Parametrix 2000b). Mitigation for impacts to the ecological functions that the wetlands provide will be mitigated as described in this document (see Chapter 5).

2.2 STREAMS

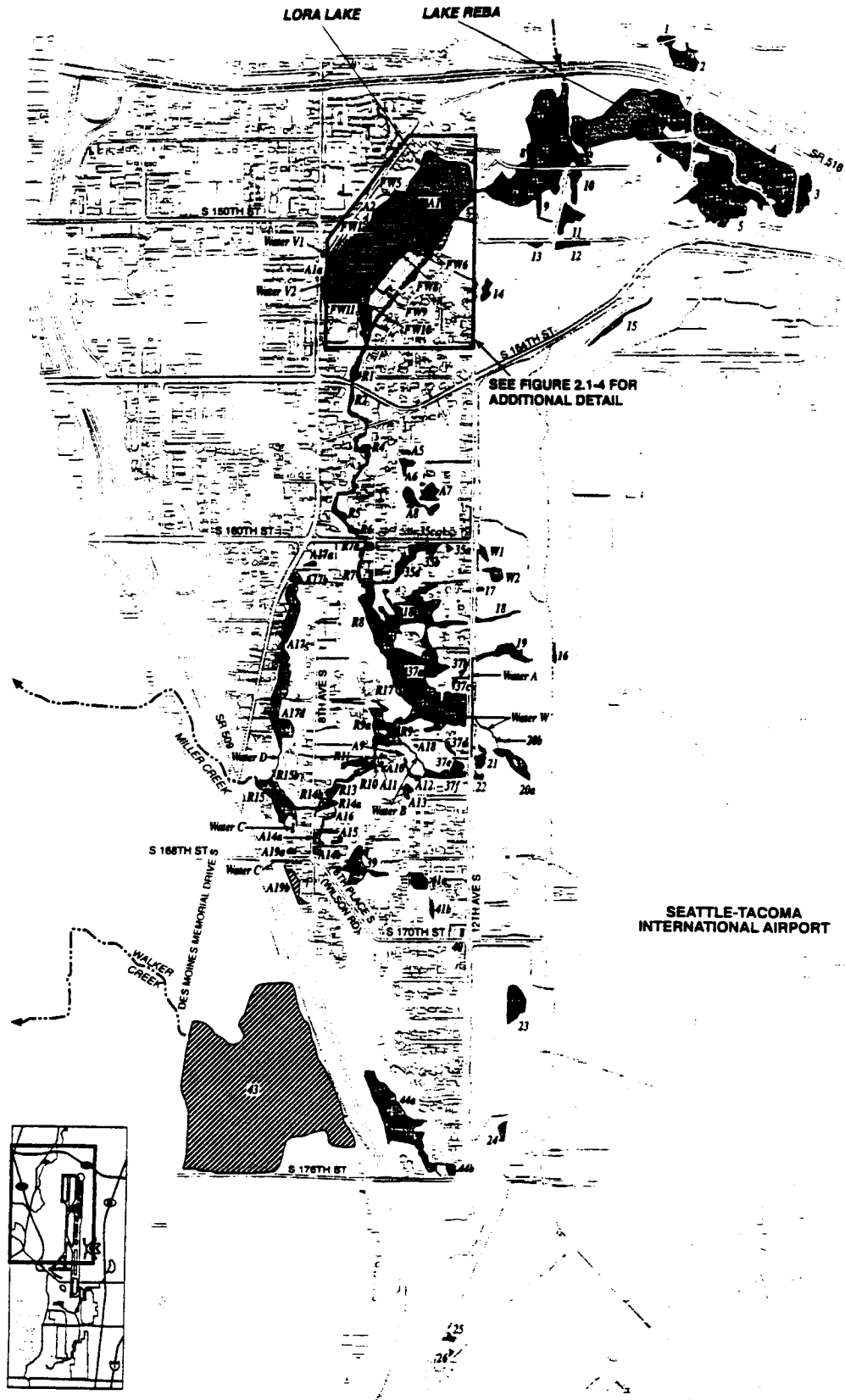
Several stream systems (Walker, Miller, Des Moines, and Gilliam Creeks) occur in the project area. These have been evaluated as part of the environmental review for the Master Plan Update improvements (FAA 1996, 1997; KCSWM 1987; Hillman et al 1999; Parametrix 2000d). The following sections describe these stream systems. Additional detailed information on existing ecological conditions in the streams is provided in the *Biological Assessment* (Parametrix 2000d), as well as in the detailed mitigation plan descriptions in Chapter 5.

2.2.1 Miller Creek Basin

Miller and Walker Creeks, the two streams located in the Miller Creek basin, are near or within the project area. Miller Creek originates at Arbor Lake (near the corner of 5th Avenue, south of South 124th Street) and flows approximately 5.3 miles to Puget Sound. Walker Creek originates in Wetland 43 west of SR 509 (U.S. Geologic Survey [USGS] Des Moines Quadrangle 1995) and flows into Miller Creek approximately 500 ft upstream of its mouth at Puget Sound (Figure 2.2-1). While a portion of the Walker Creek drainage basin is located within the study area, the stream itself is located approximately 1,000 ft downslope of, and west of, the project area.

2.2.1.1 Miller Creek

Miller Creek is located in southwest King County and has a basin size of approximately 8 square miles. The Miller Creek basin lies within the Cities of SeaTac and Burien. Flows in Miller Creek originate at three locations: (1) the Arbor, Burien, Tub, and Lora Lakes complex; (2) Lake Reba; and (3) seeps located on the west side of STIA. Miller Creek generally flows south and southwest toward Puget Sound. On the west side of the airport, a number of drainage channels convey water from the plateau and hillslope to the stream. These channels (King County 1990) have been ditched, and function primarily as surface or groundwater conveyance channels.



Note: Unshaded GIS coverage 11/2000

Port of Seattle/Airport Resource Integration Plan/95-2012-00101001 1200 (R)

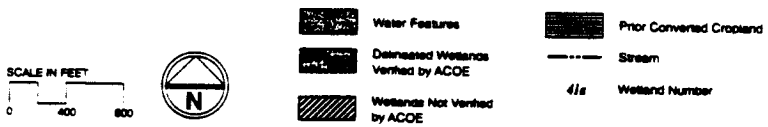
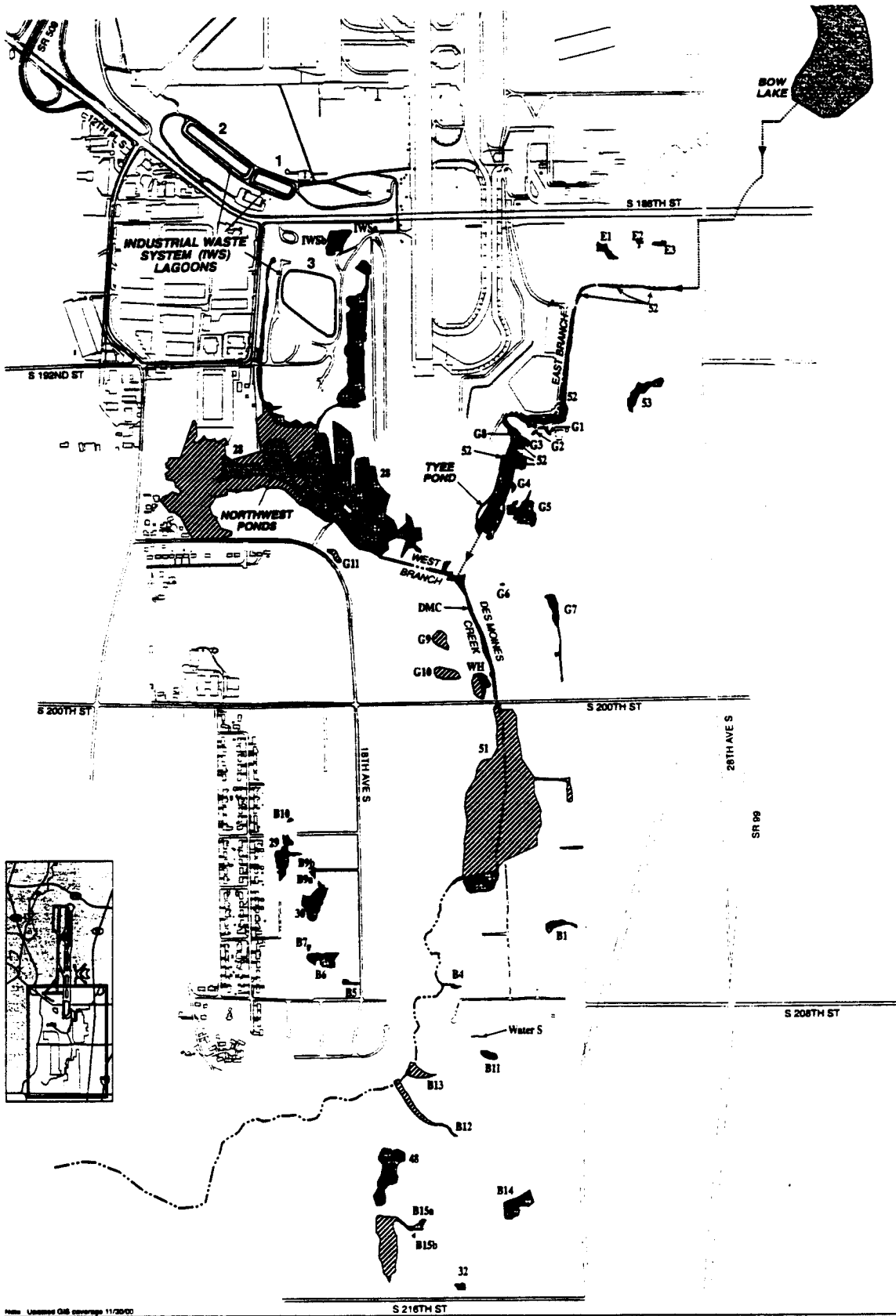
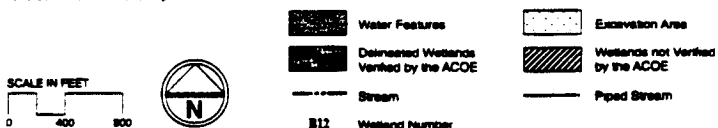


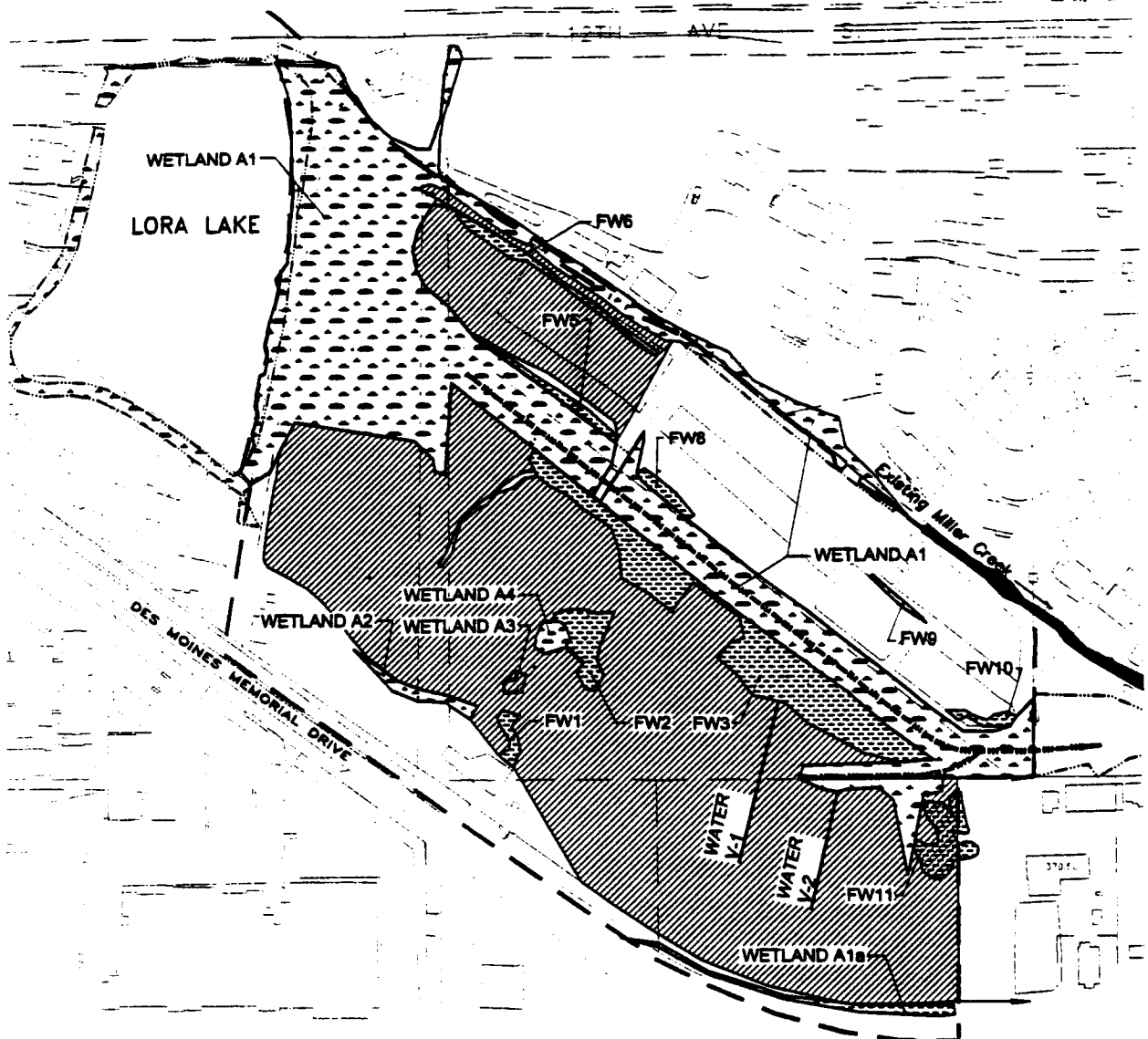
Figure 2.1-2
Wetlands in the
Miller Creek Basin
Near STIA



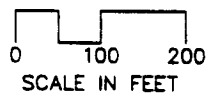
Note: Updated GIS coverage 11/20/00
 Part of Sediment/Resource Management Plan/95-2912-001/01/02/ 12/00 (R)



**Figure 2.1-3
 Wetlands in the
 Des Moines Creek Basin
 Near STIA**



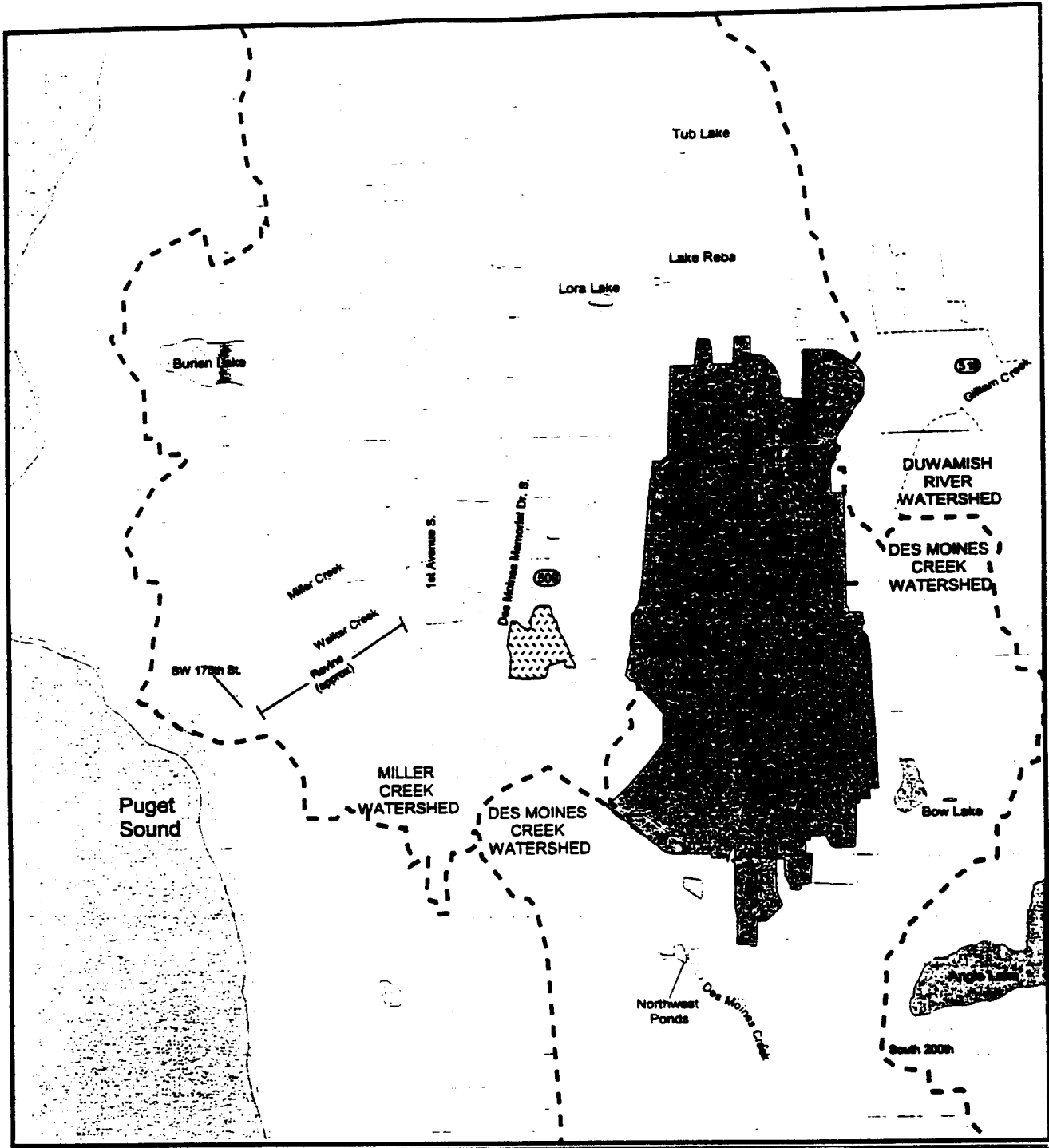
FILE: 291203_F2.2-5
 DATE: 11/27/00



LEGEND:

- Detail Area
- Drainage Ditch
- Vegetated Wetlands
- Farmed Wetlands (FW), 14 Day Inundation (Observed, 3/98)
- Prior Converted Wetlands

**Figure 2.1-4
 Jurisdictional Wetlands
 on the
 Vacca Farm Site**



Puget Sound, Inc./See-Too Airport Environmental Management Plan 200-201-01-001-001 Rev. 04/2010
 Source: Data based on King County data. Water bodies derived from 1980 topographic data. Watershed natural boundaries are based on field observations by Puget Sound, Inc.
 Land use data referenced from 1980 DTA aerial photography (color) and aerial, 1980, black and white photography.
 Note: Suburban boundaries occur outside of STA area and are shown for reference only.

Figure 2.2-1
Location of
Miller Creek,
Walker Creek,
and Des Moines
Creek Near STA



Most of the 5,050-acre Miller Creek watershed is developed with residential and commercial properties. Approximately 62 percent of the land use in the basin is residential, 15 percent is commercial, 3 percent is STIA² (excluding the Industrial Water System (IWS) drainage area, which treats stormwater runoff prior to being discharged to Puget Sound), and the remaining 20 percent is undeveloped (Montgomery Water Group 1995). Much of the undeveloped land in the watershed is owned by the Port. Commercial land uses are scattered along Des Moines Way, Ambaum Boulevard, and First Avenue South. Some agricultural uses are also found in the upper watershed. Although urbanization throughout the basin has altered the stream and riparian ecosystems, Miller Creek continues to support fish and wildlife species.

Stream Classification

WDFW has classified the lower reaches of Miller Creek as Class II salmon-bearing waters. Miller Creek is designated as an extraordinary (Class AA) quality water body by the Water Quality Standards for Surface Waters of the State of Washington (WAC 173-201). However, Miller Creek has failed to meet some of the state water quality standards (FAA 1996). Occasional violations of Class AA water quality standards for pH, dissolved oxygen, and ammonia have also occurred in the basin (FAA 1996). Runoff from residential, commercial, and agricultural properties has contributed to water quality degradation. Pollutants such as nutrients, organics, metals, fecal coliform bacteria, and suspended solids commonly associated with urban runoff, have been found in Miller Creek and contribute to occasional violations of state and federal water quality standards.

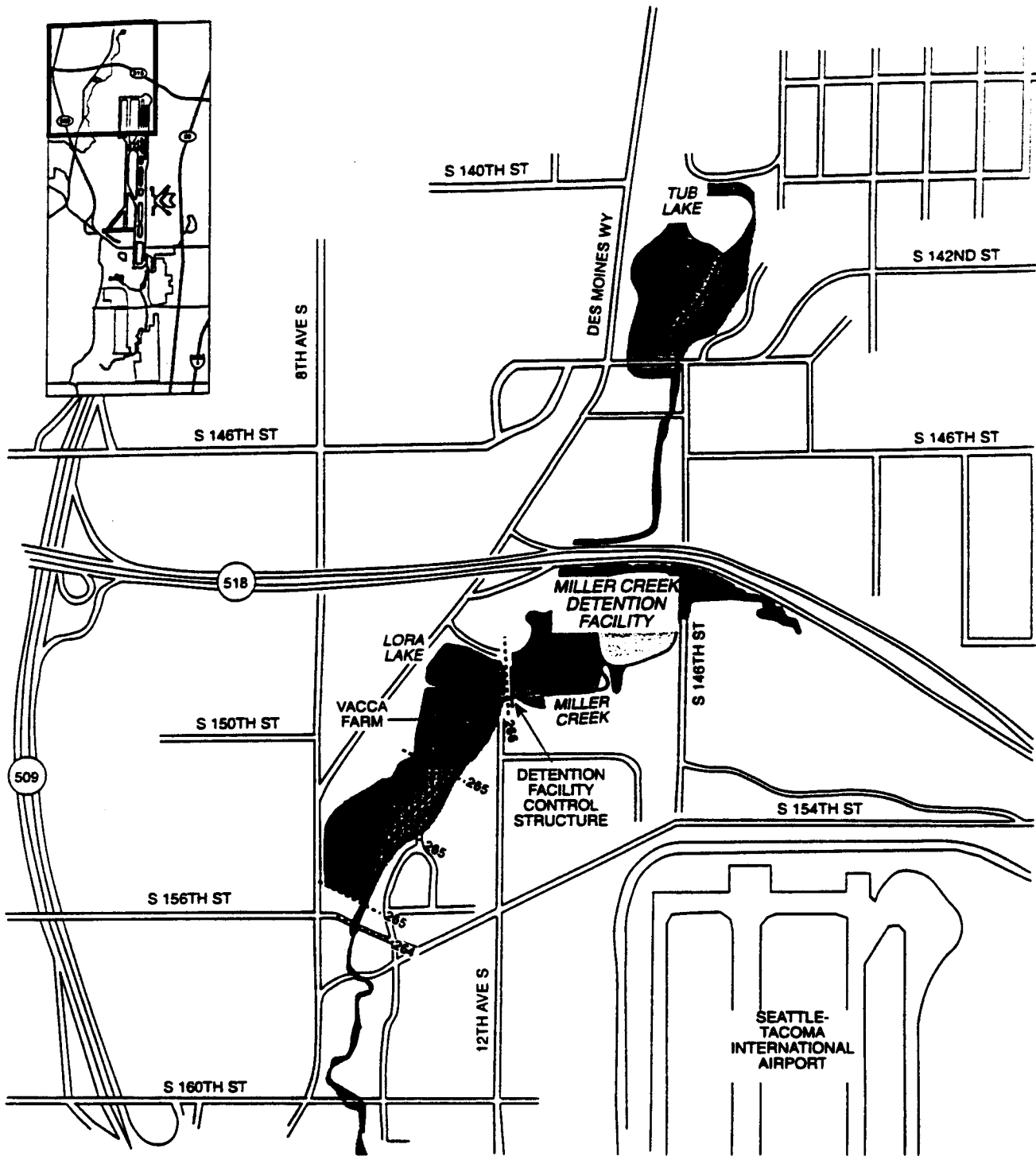
The floodplain in the stream reach between South 156th Street and South 160th Street is relatively confined to the channel ravine and is approximately 60 to 100 ft wide. In the stream reach south of South 160th Street, the floodplain is approximately 80 to 150 ft wide in the upper reaches. However, further downstream, it widens to approximately 200 to 250 ft.

Urbanization and agriculture have significantly altered the floodplains associated with Miller Creek. The wetland filling, riparian vegetation removal, culvert installation, and streambank armoring have reduced stream channel and floodplain capacities. Increased development and impervious surface areas in the basin result in increased stormwater runoff rates and volumes.

The 100-year floodplain in the vicinity of the Vacca Farm site is several acres in size (Figure 2.2-2). The wetland area and poor drainage that existed prior to land agricultural drainage activities are evident from the 100-year floodplain estimated by the Federal Emergency Management Agency (FEMA). The approximate 100-year flood elevations, determined by FEMA as part of its study, vary from 266 ft at the Miller Creek detention facility outlet, to approximately 265 ft at the downstream end of the Vacca Farm site (see Figure 1.2-2). A floodway has also been delineated and mapped in a portion of the floodplain.

The floodplain in the reach between South 156th Street and South 160th Street is relatively confined to the channel ravine and is approximately 60 to 100 ft wide. In the reach south of South 160th Street, the floodplain is approximately 80 to 150 ft wide in the upper reaches. However, further downstream, it widens to approximately 200 to 250 ft.

² This area will increase to 9 percent with acquisition of west side property.



Source: FEMA 1995

Port of Seattle/Natural Resource Mitigation Plan/566-2912-001/01(03) 11/00 (K)



NOT TO SCALE

- 100-year Flood Elevation (approximately 265.4 ft)
- ▨ Floodway
- 100-Year Floodplain

**Figure 2.2-2
Miller Creek
100-Year Floodplain**

AR 048634

Miller Creek Tributary Drainage Channels

Five intermittent water drainage channels (referred to as Waters A, B, C, D, and W) are located within the Miller Creek basin in the acquisition area on the west side of the existing runway (see Figure 2.1-2). These channels are regulated as Waters of the U.S. by ACOE, and portions of them are mapped by the *King County Sensitive Areas Portfolio* (King County 1990).

Water A is an approximately 814-ft-long by 5-ft-wide (0.09-acre) drainage ditch. This ditch collects surface water runoff from 12th Avenue South, the airport security road, and several upslope wetlands (Wetlands 19, 21, and 22). A portion of Water W, which originates in Wetland 20, also drains westward into Water A. These waters drain into Wetland 37 through a culvert under 12th Avenue South and convey channelized flow through a continuation of Water W for approximately 494 feet (0.03 acre) to Miller Creek. Water A and portions of Water W are mapped in the King County sensitive area map folio (King County 1990) as an unclassified stream.

Water B is an approximately 314-ft-long by 4-ft-wide (0.03-acre) incised channel that conveys water from the west end of Wetland 37f northwest to riparian Wetland R9, which, in turn, drains to Miller Creek.

Water C is a discontinuous ditch that flows through culverts or cement-lined channels on Parcel 251. The exposed ditch totals approximately 170 linear feet (0.01 acre) from South 168th Street to Miller Creek.

Water D is an intermittent stream that begins east of Des Moines Memorial Drive and north of South 160th Street. The channel flows approximately 1,830 linear feet (0.16 acre) through several sections of Wetland A17 and enters Miller Creek on Parcel 243, approximately 200 feet upslope of Des Moines Memorial Drive.

2.2.1.2 Walker Creek

Walker Creek is the major tributary of Miller Creek and originates in Wetland 43 west of SR 509. Several small seep areas located east of SR 509 feed into Wetland 43. Walker Creek flows for approximately 1.3 miles southwest and generally parallel to Miller Creek before joining Miller Creek less than 500 ft upstream of Puget Sound (see Figure 2.2-1). Land use in the Walker Creek basin consists of residential and commercial development in densities similar to those described for Miller Creek. A small portion of Port property drains to Walker Creek. However, no portion of the active runway, airfield, or airport operations area drains to Walker Creek.

The contributing basin to Walker Creek, including Wetland 43, is shown in Figure 2.2-1. Stream flow rates are typically highest between October and April during the wet season and lowest between May and September (FAA 1996). Walker Creek receives stormwater runoff originating from residential and commercial development within the basin, which has likely increased the frequency and magnitude of peak flows. Upstream of Southwest 175th Street, the Federal Emergency Management Agency (FEMA) classified the floodplain as areas where the 100-year flood depth is less than 1.0 ft, or the drainage area is less than 1 square mile. FEMA also mapped a more extensive (several acres) floodplain from the confluence of Walker and Miller Creeks to Puget Sound.

In the lower gradient upper reaches, Walker Creek flows through confined rocky hardened banks, several culverts, and along roadside ditches. As the gradient increases, Walker Creek flows through a ravine (downstream of 1st Avenue South); however, field evaluations of this area could not be conducted due to limited access to private property. As the gradient decreases below the ravine and above the confluence with Miller Creek, the stream is again confined by urban development, including yards, ditches, and culverts. Walker Creek has riparian cover along most of its length. Trees and shrubs are the dominant vegetation type, however mowed lawn is also common along the banks (Hillman et al. 1999).

Walker Creek is unclassified by King County, however, it would likely be classified as a DNR type 3 stream due to stream size and salmonid use. No studies have measured water quality in Walker Creek; it is likely that the stream has pollutant loads typical of streams in Puget Sound lowland urbanized watersheds, and similar to Miller Creek. Walker Creek supports coho and chum spawning, although a recent survey found that approximately 75 percent of the coho spawning in the stream were from hatcheries (Hillman et al. 1999). The stream has limited large woody debris, undercut banks, or other types of cover features (Hillman et al. 1999), which in turn limits fish habitat in the stream.

2.2.2 Des Moines Creek Basin

The Des Moines Creek drainage basin consists of about 3,525 acres situated primarily south and southeast of the airport (see Figure 1.2-2). The Des Moines Creek watershed is largely urbanized and includes portions of the Cities of Des Moines, Normandy Park, SeaTac, and Burien. STIA occupies approximately 23 percent of the watershed (excluding other Port properties such as Tyee Valley Golf Course and noise abatement areas). The area directly southeast of the airport, once residential, has largely been purchased by the Port as part of the Noise Remedy Program. The Tyee Valley Golf Course occupies the area immediately south of the airport. The remainder of the watershed is mixed residential, commercial, and industrial uses.

2.2.2.1 Des Moines Creek

The east branch of Des Moines Creek originates from Bow Lake, and the west branch originates from the Northwest Ponds. From the confluence of the two branches on the Tyee Valley Golf Course, Des Moines Creek extends about 3.5 miles southeast to Puget Sound. In that distance it drops about 300 ft in elevation. Two unnamed tributaries enter the stream at about river miles (RMs) 0.7 and 1.9 (Williams et al. 1975).

Des Moines Creek is designated as an extraordinary (Class AA) quality water body by the Water Quality Standards for Surface Waters of the State of Washington (WAC 173-201). From the west branch downstream of the Northwest Ponds, it is a Class II salmon-bearing stream.

2.2.2.2 Drainage Channel

A small drainage channel (Water S) is present in Borrow Area 1, South of South 208th Street and east of Des Moines Creek (see Figure 2.1-3). Water S, classified as a Water of the U.S., contains

intermittent flow, but does not contain wetland soil or vegetation. Water S is a 90-ft-long by 3-ft-wide (0.01-acre) channel that conveys water from a small spring into a 4-inch drainage pipe.

2.2.3 Gilliam Creek

Gilliam Creek³ is a small stream that receives runoff from STIA, and discharges to the Green/Duwamish River in the vicinity of the city of Tukwila (see Figure 2.2-1). This stream is used primarily by resident fish because of migration barriers that limit anadromous fish passage (Taylor Associates 1996 in City of Tukwila 1997). Gilliam Creek, which has been impacted by development, is extensively culverted and receives stormwater runoff that causes high peak flows and low base flows. Access by fish to the lower reaches of Gilliam Creek is restricted by a culvert and flap gate where the stream drains into the Green/Duwamish River. Culverts limit adult salmonid access to much of this tributary, although juvenile chinook and coho salmon have been reported in the stream. The resident fishes expected to inhabit this stream and long piped sections include cutthroat trout (*Oncorhynchus clarki clarki*), western brook lamprey (*Lampetra richardsoni*), carp (*Cyprinus* sp.), peamouth (*Mylocheilus caurinus*), largescale sucker (*Catostomus macrocheilus*), threespine stickleback (*Gasterosteus aculeatus*), and sculpin (*Cottus* sp.).

About 50 percent of Gilliam Creek is contained in culverts, and much of the remainder of the stream flows in constructed ditches. Riparian vegetation is lacking along most of the stream corridor or is predominantly herbaceous and provides little shade.

Urban developments within the watershed have altered native soils and vegetation, resulting in increased scour and sedimentation in Gilliam Creek. Changes such as stream channelization and the removal of large woody debris have increased stream degradation and fine sediment input. Scour and erosion characterize the upper reaches of the stream, resulting in downstream sedimentation in the lower reaches. Base flow measurements of water quality indicated that concentrations in Gilliam Creek do not meet Washington State Class A water quality standards for pH, dissolved oxygen, dissolved copper, dissolved lead, dissolved zinc, and fecal coliform bacteria (Herrera and RW Beck 2000).

³ Gilliam Creek is described in this section. Master Plan Update improvements do not add new impervious area or alter any wetlands or stream channels in this basin. For these reasons, no natural resource mitigation in this basin is necessary.

**Natural Resource
Impacts**

AR 048638

3. NATURAL RESOURCE IMPACTS SUMMARY

The STIA Master Plan Update improvements will affect wetlands, streams, floodplain, drainage channels, and stormwater in the Miller and Des Moines Creek basins. To construct the projects, fill material would be placed in approximately 980 linear ft of Miller Creek, approximately 5.24 acre-ft of the Miller Creek 100-year floodplain, approximately 18.37 acres of wetland, and about 1,290 linear ft of drainage channel. In addition, new impervious surfaces will affect stormwater runoff and water quality conditions. The impacts of these actions, which are the basis for the mitigation described in Chapters 4, 5, and 7 of this report, are described in the FSEIS (FAA 1997a) for the project. Wetland and stream impacts resulting from STIA Master Plan Update improvements are summarized in the discussion that follows. Detailed analyses of these impacts are presented in the following documents:

- *Wetland Functional Assessment and Impact Analysis* (Parametrix 2000b)
- *Comprehensive Stormwater Management Plan for Seattle-Tacoma International Airport Master Plan Improvements* (Parametrix 2000a)
- *Final Supplemental Environmental Impact Statement for the Proposed Master Plan Update Development Actions at Seattle-Tacoma International Airport* (FAA 1997a)

3.1 WETLANDS

The FSEIS for the Master Plan Update improvements identified 12.23 acres of wetland that would be directly affected by Master Plan Update improvements (FAA 1997a; Parametrix 1996a). These determinations represented the best available information at the time of publication. Information supporting these determinations was obtained through field delineations and aerial photographic interpretation. Aerial photographic interpretation was used in the west side acquisition area where the Port lacked the access to properties necessary to conduct wetland delineations and subsequent agency review.

Since the publication of the FSEIS, the Port has purchased property and delineated wetlands that are subject to temporary or permanent impacts from the runway embankment, construction activities, and stormwater management (see *Wetland Delineation Report*, Parametrix 2000c). All wetlands within the acquisition area have been delineated.

Permanent wetland impact from Master Plan Update improvements would affect about 18.37 acres (Table 3.1-1, Figures 3.1-1 and 3.1-2, and the *Wetland Functional Assessment and Impact Analysis* [Parametrix 2000b]). Mitigation for these impacts is described in Chapters 4 (overview), 5 (in-basin for non-habitat wetland functions), and 7 (out-of-basin for habitat mitigation).

Permanent wetland impacts (fill and potential indirect) include approximately 8.17 acres of forest, 2.98 acres of shrub, and 7.22 acres of emergent habitat. Lower quality wetlands (Category III and Category IV) account for about 50 percent of the wetlands impacted by fill (Table 3.1-2). The remaining wetland impact areas affect higher quality Category II wetlands. All impacted wetlands have been subjected to significant historical or ongoing disturbances that have reduced their ecological value and ecosystem function (Parametrix 2000b).

Table 3.1-1. Summary of wetland impacts for Seattle-Tacoma International Airport Master Plan Update improvements by construction project (all values are in acres).

Wetland Number	Vegetation Type ¹	Indirect Impact (acres)	Direct Impact (acres)	Total Impact (acres) ²	Vegetation Types Impacted (acres)		
					Forested	Shrub	Emergent
Runway Safety Area Extension							
5	Shrub	0.00	0.14	0.14	0.07	0.07	0.00
	Subtotal	0.00	0.14	0.14	0.07	0.07	0.00
Third Runway Project Area							
<u>North Airfield</u>							
9	Forested/Emergent	0.00	0.03	0.03	0.01	0.00	0.02
11	Forested/Emergent	0.16	0.34	0.50	0.40	0.00	0.10
12	Forested/Emergent	0.00	0.21	0.21	0.04	0.00	0.17
13	Emergent	0.00	0.05	0.05	0.00	0.00	0.05
14	Forested	0.00	0.19	0.19	0.19	0.00	0.00
<u>West Airfield</u>							
15	Emergent	0.00	0.28	0.28	0.00	0.00	0.28
16	Emergent	0.00	0.05	0.05	0.00	0.00	0.05
17	Emergent	0.00	0.02	0.02	0.00	0.00	0.02
18	Forested/Shrub/ Emergent	0.55	2.29	2.84	1.28	0.75	0.81
19	Forested	0.00	0.56	0.56	0.56	0.00	0.00
20	Shrub/Emergent	0.00	0.57	0.57	0.00	0.51	0.06
21	Forested	0.00	0.22	0.22	0.22	0.00	0.00
22	Shrub/Emergent	0.00	0.06	0.06	0.00	0.01	0.05
23	Emergent	0.00	0.77	0.77	0.00	0.00	0.77
24	Emergent	0.00	0.14	0.14	0.00	0.00	0.14
25	Forested	0.00	0.06	0.06	0.06	0.00	0.00
26	Emergent	0.00	0.02	0.02	0.00	0.00	0.02
W1	Forested/Emergent	0.00	0.10	0.10	0.00	0.00	0.10
W2	Forested/Emergent	0.00	0.22	0.22	0.04	0.00	0.18
<u>West Acquisition Area</u>							
35a-d	Forested/Emergent	0.04	0.63	0.67	0.27	0.00	0.40
37a-f	Forested/Emergent	0.36	3.75	4.11	2.86	0.00	1.25
40	Forested	0.00	0.03	0.03	0.00	0.03	0.00
41a and b ³	Emergent	0.00	0.44	0.44	0.00	0.00	0.44
44a and b	Forested	0.00	0.26	0.26	0.18	0.08	0.00
A5	Emergent	0.02	0.01	0.03	0.00	0.00	0.03
A6	Forested	0.09	0.07	0.16	0.16	0.00	0.00
A7	Forested	0.00	0.30	0.30	0.30	0.00	0.00
A8	Forested/Shrub	0.00	0.38	0.38	0.07	0.31	0.00
A12	Shrub	0.06	0.02	0.08	0.00	0.08	0.00
A 18	Shrub	0.01	0.00	0.01	0.00	0.01	0.00

Table 3.1-1. Summary of wetland impacts for Seattle-Tacoma International Airport Master Plan Update improvements by construction project (all values are in acres) (continued).

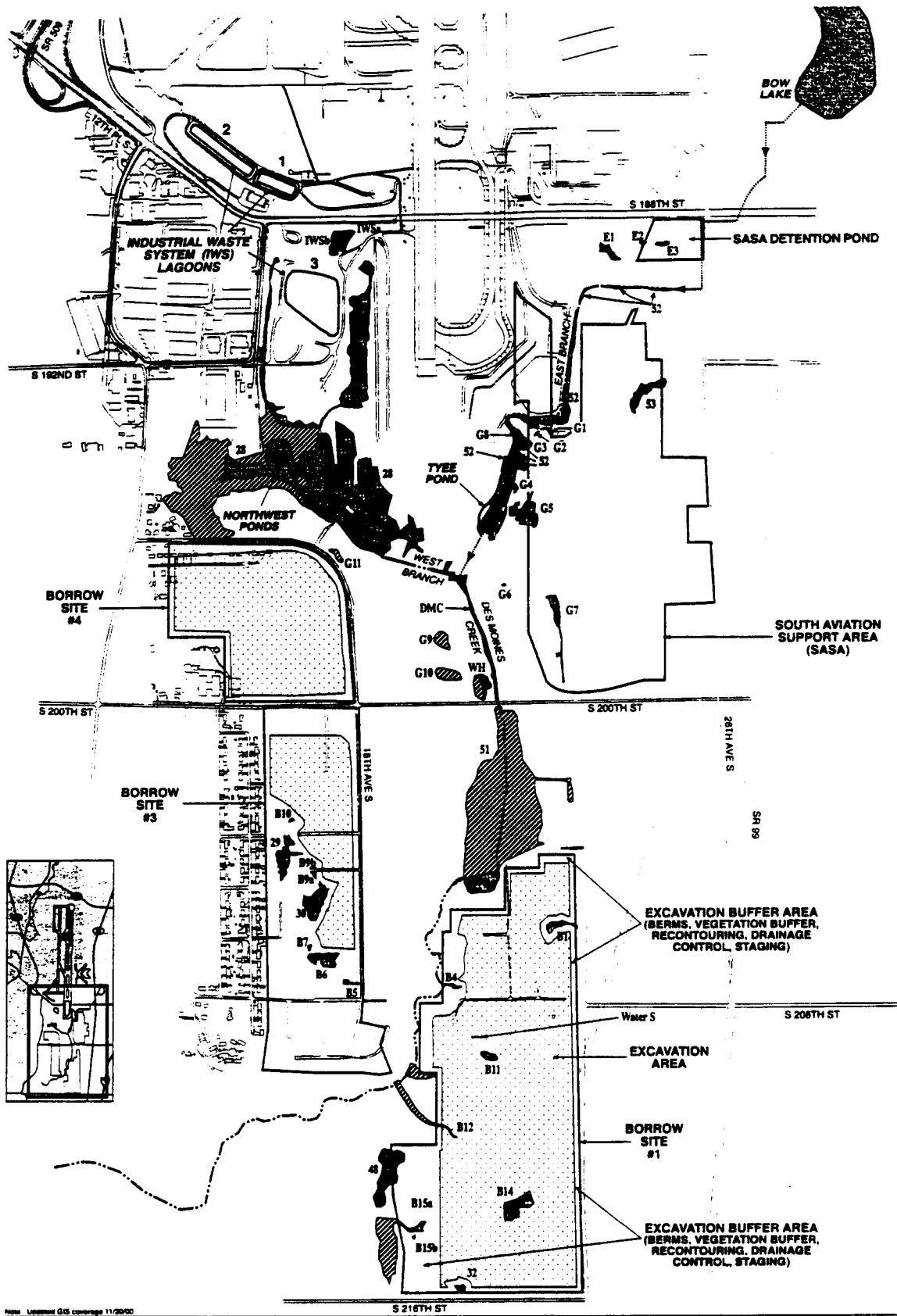
Wetland Number	Vegetation Type ¹	Indirect Impact (acres)	Direct Impact (acres)	Total Impact (acres) ²	Vegetation Types Impacted (acres)		
					Forested	Shrub	Emergent
Vacca Farm Site							
A1	Forested/Shrub/ Emergent	0.00	0.59	0.59	0.09	0.09	0.41
FW 5	Farmed Wetland	0.00	0.08	0.08	0.00	0.00	0.08
FW 6	Farmed Wetland	0.00	0.07	0.07	0.00	0.00	0.07
Riparian Wetland							
R1	Emergent	0.00	0.13	0.13	0.00	0.00	0.13
	Subtotal	1.29	12.94	14.23	6.73	1.87	5.63
South Aviation Support Area (SASA)/Tyee Valley Golf Course							
52	Forested/Shrub/ Emergent	0.54	0.00	0.54	0.54	0.00	0.00
53	Forested	0.00	0.60	0.60	0.60	0.00	0.00
E2	Forested	0.00	0.04	0.04	0.04	0.00	0.00
E3	Forested	0.00	0.06	0.06	0.06	0.00	0.00
G1	Shrub (Slope)	0.00	0.05	0.05	0.00	0.05	0.00
G2	Emergent	0.00	0.02	0.02	0.00	0.00	0.02
G3	Emergent	0.02	0.04	0.06	0.00	0.00	0.06
G4	Emergent	0.04	0.00	0.04	0.00	0.00	0.04
G5	Emergent	0.47	0.40	0.87	0.00	0.00	0.87
G7	Forested/Shrub	0.00	0.50	0.50	0.13	0.37	0.00
	Subtotal	1.07	1.71	2.78	1.37	0.42	0.99
Borrow Area and Haul Road							
28	Emergent	0.00	0.07	0.07	0.00	0.00	0.07
B11	Emergent	0.00	0.18	0.18	0.00	0.00	0.18
B12	Forested	0.04	0.03	0.07	0.00	0.07	0.00
B14	Shrub	0.00	0.78	0.78	0.00	0.55	0.23
	Subtotal	0.04	1.06	1.10	0.00	0.62	0.48
Mitigation⁴							
Auburn area 7	Emergent	0.00	0.02	0.02	0.00	0.00	0.02
Auburn area 9	Emergent	0.00	0.03	0.03	0.00	0.00	0.03
Auburn area 10	Emergent	0.00	0.07	0.07	0.00	0.00	0.07
	Subtotal	0.00	0.12	0.12	0.00	0.00	0.12
TOTAL		2.40	15.97	18.37	8.17	2.98	7.22

¹ All wetlands are palustrine, based on USFWS wetland classification system (Cowardin et al. 1979).

² Values are rounded to two significant figures. Wetland impact may be subject to minor changes.

³ Includes 0.18 acre of open water habitat.

⁴ Impacts result from access roads.



Note: Utilized GIS coverage 11/20/00
 Part of Soils/Water Resources Mapsheet P49168-2912-001/01/001 12/00 (R)

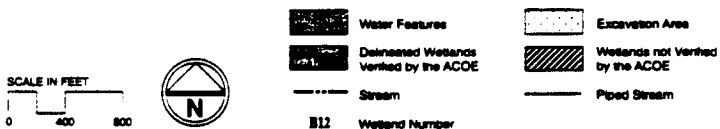


Figure 3.1-2
 Wetland Impacts in the
 Des Moines Creek Basin
 Near STIA

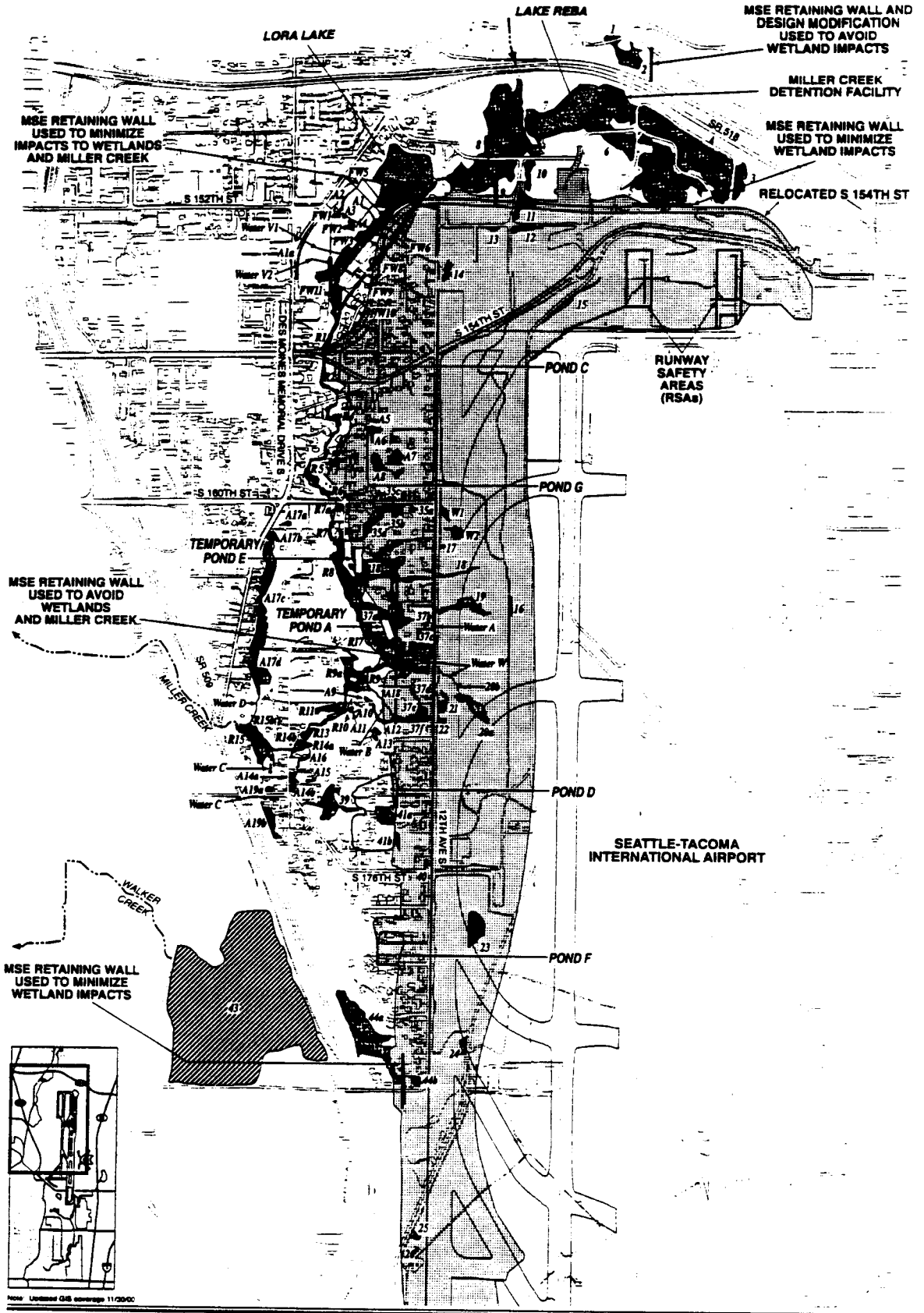


Figure 3.1-1
Wetland Impacts in the
Miller Creek Basin
Near STIA

Table 3.1-2. Summary of permanent wetland impacts by project and wetland category¹ (in acres).

Project	Category II	Category III	Category IV	Total
RSA	0.00	0.14	0.00	0.14
Third Runway	8.37	4.89	0.97	14.23
Borrow Area 1 and Haul Rd	0.14	0.96	0.00	1.10
SASA	0.54	1.20	1.04	2.78
Off-site Mitigation ²	0.00	0.12	0.00	0.12
TOTAL	9.05	7.31	2.01	18.37

¹ Ecology (1993)

² Impacts result from a permanent access road in an emergent wetland at the Auburn mitigation project.

During Master Plan Update improvement project construction, about 2.05 acres of wetland could temporarily be disturbed by construction activities, stormwater management, and temporary erosion and sediment control facilities (Table 3.1-3 and Figure 3.1-3) (Parametrix 2000b). Upon completion of construction, temporarily impacted areas will be restored. Restoration activities will include removing invasive plant species, planting native species, and regrading of temporarily impacted emergent wetlands to create higher quality forest, shrubs, and open water wetlands.

Additional impacts to wetlands that result from implementing the mitigation projects include constructing temporary and permanent access roads in wetlands and use of wetlands for temporary construction staging. Areas subject to temporary construction impacts will be regraded and replanted following construction.

Table 3.1-3. Summary of temporary construction impacts to wetlands in the proposed Seattle-Tacoma International Airport Master Plan Update improvement area.

Wetland	Classification ¹	Total Temporary Impact Area (acres)	Vegetation Type Impacted (acres)		
			Forest	Shrub	Emergent
Runway Safety Area Extension					
4	Forested ²	0.20	0.20	0.00	0.00
5	Forested/Shrub ²	0.20	0.10	0.10	0.00
Third Runway					
9	Forested/Emergent	0.16	0.11	0.00	0.05
18	Forested/Shrub/Emergent	0.22	0.04	0.07	0.11
37	Forested/Shrub/Emergent	0.71	0.50	0.10	0.11
44a	Forested/Shrub	0.28	0.18	0.10	0.00
A1	Forested/Shrub/Emergent ²	0.05	0.01	0.01	0.03
A12	Shrub	0.03	0.00	0.03	0.00
A13	Forested	0.01	0.01	0.00	0.00
R2	Emergent	0.02	0.00	0.00	0.02
South Aviation Support Area					
52	Forested/Shrub/Emergent ²	0.17	0.00	0.05	0.12
TOTAL		2.05	1.15	0.46	0.44

¹ All wetlands are palustrine, based on USFWS wetland classification system (Cowardin et al. 1979).

² Temporary impacts will be limited to installation of sediment fencing and standard BMPs.

Approximately 40.49 acres of wetland will be disturbed during mitigation activities (Table 3.1-4) (Parametrix 2000b).

Table 3.1-4. Summary of wetlands disturbed during mitigation activities.

Wetland	Vegetation Types	Total Area (acres)	Vegetation Type Disturbed (acres)		
			Forest	Shrub	Emergent
Temporary impacts to wetlands associated with implementing mitigation that includes excavation or installation of temporary roads					
FW 1, 2, 3, 8, 9, 10, and FW 11 ¹	Farmed Wetlands	0.88	0.00	0.00	0.88
A1 ¹	Forest/Shrub/Emergent	3.74	0.56	0.56	2.62
A2 ¹	Shrub	0.05	0.00	0.05	0.00
A3 ¹	Shrub	0.01	0.00	0.01	0.00
A4 ¹	Shrub	0.03	0.00	0.03	0.00
Auburn Area 1 ²	Emergent	1.55	0.00	0.00	1.55
Auburn Area 2 ³	Emergent	0.06	0.00	0.00	0.06
Auburn Area 3 ³	Emergent	5.11	0.00	0.00	5.11
Auburn Area 4 ³	Emergent	0.99	0.00	0.00	0.99
Auburn Area 5 ³	Emergent	3.27	0.00	0.00	3.27
Auburn Area 6 ³	Emergent	0.35	0.00	0.00	0.35
Auburn Area 8 ³	Emergent	0.60	0.00	0.00	0.60
Auburn Area 11 ³	Emergent	0.01	0.00	0.00	0.01
Auburn ⁴	Emergent	2.20	0.00	0.00	2.20
	Subtotal	18.85	0.56	0.65	17.64
Temporary impacts in wetlands associated with enhancement planting					
18 ⁵	Forest/Shrub/Emergent	1.27	1.27	0.00	0.00
28 ⁶	Forest/Shrub/Emergent	4.50	0.00	0.00	4.50
37a ^{5,9}	Forest/Emergent	1.96	1.50	0.00	0.46
A1 ^{5,9}	Forest/Shrub/Emergent	0.34	0.34	0.00	0.00
A9 ^{5,9}	Shrub	0.04	0.00	0.04	0.00
A10 ^{5,9}	Shrub	0.01	0.00	0.01	0.00
A11 ^{5,9}	Shrub	0.02	0.00	0.02	0.00
A13 ^{5,9}	Forest	0.12	0.12	0.00	0.00
A16 ^{5,9}	Shrub/Emergent	0.05	0.00	0.00	0.05
R1 ⁵	Emergent	0.04	0.00	0.00	0.04
R2 ^{5,9}	Shrub/Emergent	0.12	0.00	0.06	0.06
R3 ^{5,9}	Shrub	0.02	0.00	0.02	0.00
R4 ^{5,9}	Emergent	0.11	0.00	0.00	0.11
R4 ^{2,5,9}	Forest/Emergent	0.11	0.03	0.00	0.08
R5 ^{5,9}	Emergent	0.05	0.00	0.00	0.05
R5 ^{2,5,9}	Forest/Emergent	0.07	0.02	0.00	0.05
R6 ^{5,9}	Forest/Emergent	0.21	0.05	0.00	0.16
R6 ^{2,5,9}	Emergent	0.09	0.00	0.00	0.09
R7 ^{5,9}	Forest/Emergent	0.04	0.04	0.00	0.00
R7 ^{1,5,9}	Emergent	0.04	0.04	0.00	0.00
R8 ^{5,9}	Shrub/Emergent	0.40	0.00	0.20	0.20
R9 ^{5,9}	Forest	0.38	0.38	0.00	0.00

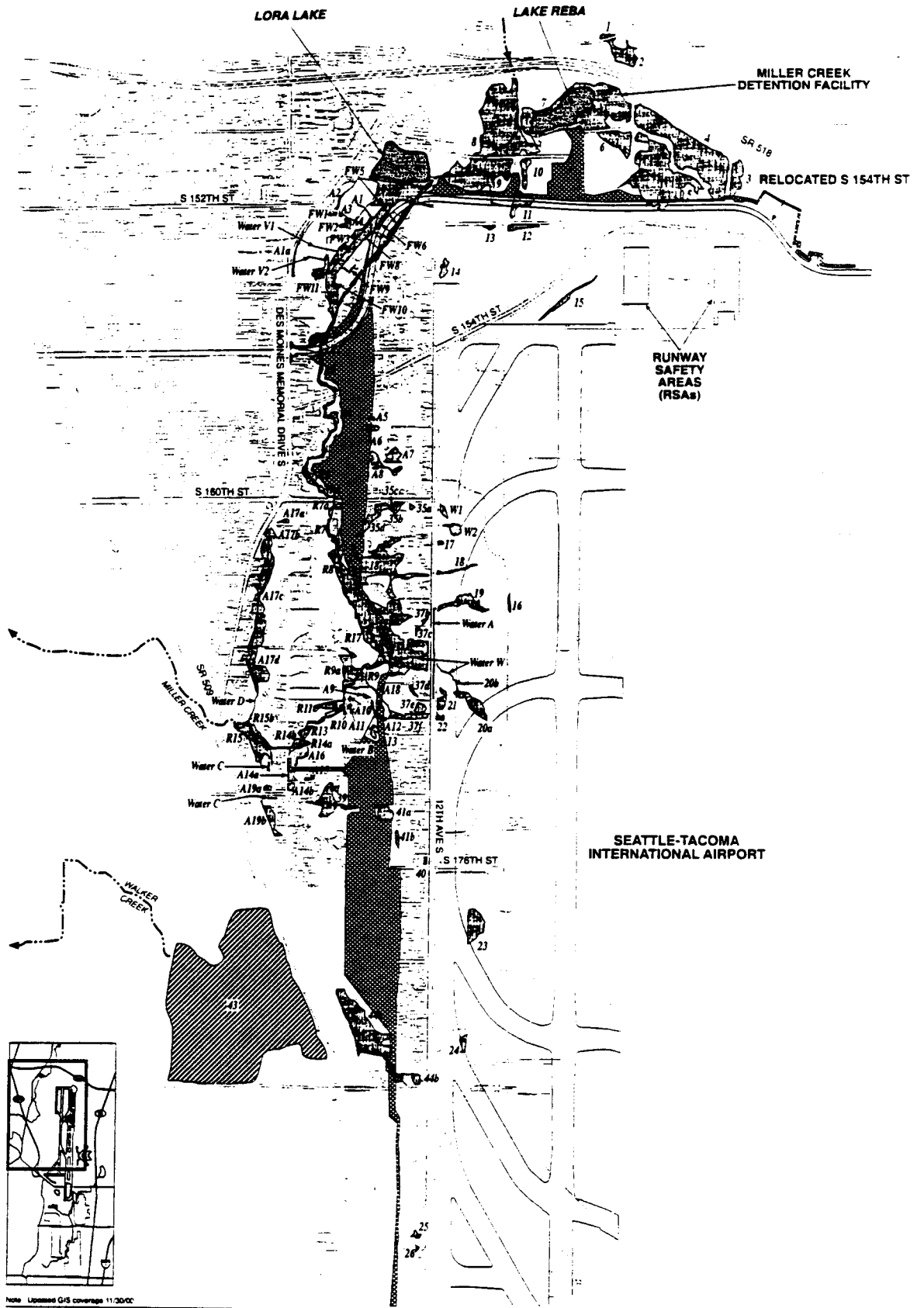
Table 3.1-4. Summary of wetlands disturbed during mitigation activities (continued).

Wetland	Vegetation Types	Total Area (acres)	Vegetation Type Disturbed (acres)		
			Forest	Shrub	Emergent
R9 ^{1,5,9}	Forest/Shrub/Emergent	0.30	0.30	0.00	0.00
R10 ^{5,9}	Shrub	0.04	0.04	0.00	0.00
R11 ^{5,9}	Emergent	0.42	0.00	0.00	0.42
R12 ^{5,9}	Forest	0.03	0.03	0.00	0.00
R13 ^{5,9}	Emergent	0.12	0.00	0.00	0.12
R14 ^{1,5,9}	Shrub/Emergent	0.13	0.13	0.00	0.00
R14 ^{2,5,9}	Emergent	0.08	0.00	0.00	0.08
R15 ^{1,5,9}	Forest/Shrub/Emergent	0.79	0.25	0.40	0.14
R15 ^{2,5,9}	Forest/Emergent	0.25	0.06	0.00	0.19
R17 ^{5,9}	Forest	0.31	0.31	0.00	0.00
Waters B, V1 ⁷ , V2 ⁷	Open Water	0.05	0.00	0.00	0.05
Auburn ⁸	Emergent	9.13	0.00	0.00	9.13
	Subtotal	21.64	4.91	0.75	15.98
TOTAL		40.49	5.47	1.40	33.62

- ¹ Temporary impacts associated with restoration activities at the Vacca Farm site.
- ² Temporary impacts result from constructing temporary roads to provide access to the mitigation site.
- ³ Excavation in wetlands at off-site mitigation site to increase habitat diversity/complexity, construction of temporary roads to access the interior portion of the site to conduct monitoring and maintenance activities, and approximately 3 acres of temporary staging area.
- ⁴ Maximum of 2.20 acres of existing off-site ditches and farmed wetland will be converted to a wetland drainage channel that connects the mitigation site to the 100-year floodplain of the Green River.
- ⁵ Enhancements in these wetlands may include excavation for temporary irrigation systems.
- ⁶ Planting and removal of culverts in wetland located at the Tyee Valley Golf Course.
- ⁷ Existing drain tiles will be removed and natural wetland topography restored.
- ⁸ Mowing, discing, and planting in an existing low quality emergent wetland.
- ⁹ Wetlands in the Miller Creek and Riparian buffer.

Where fill impacts to wetlands result in small fragments of remaining wetlands, the remaining wetland area has been considered permanently impacted, and tabulated in Table 3.1-1. For example, the small areas of Wetland A6 and A8 located between the runway embankment and proposed stormwater detention facilities may not persist as functioning wetland following completion of the project.

The calculated permanent impacts to wetlands (18.37 acres) also include about 2.4 acres of indirect wetland impacts (see Table 3.1-1) that could occur in certain locations where there are changes to wetland hydrology, shading, or fragmentation resulting in loss of wetland functions (Parametrix 2000b). While these indirect impacts could result in the loss of some wetland functions from an area, they may not necessarily remove all functions. For example, where the SASA bridge crosses Wetland 52, shading will eliminate wetland vegetation and wildlife habitat, however, the corridor and hydrologic functions provided by this area will remain. In other areas, if wetland hydrology is reduced or eliminated, existing vegetation will remain and wildlife habitat will continue to be provided. However, these indirect impacts are mitigated at ratios of 3:1.



Note: Updated GIS coverage 11/20/02

Part of Seattle/Hastings Resource Mapping Plan 946-2912-001(01)(02) 12/00 (R)

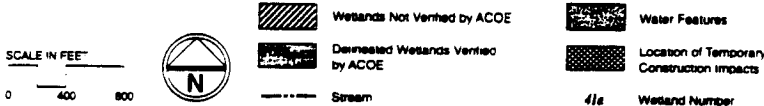


Figure 3.1-3
Location of Temporary Wetland
Impacts in the Miller Creek
Basin Near STIA

Other indirect impacts to wetlands that could affect their function include noise and human disturbance, changes in water quality impacts, and changes in surface hydrology. These impacts could alter or reduce the level of some functions, but would not eliminate the wetlands themselves or their functions. These impacts are also mitigated by this plan because, in most cases, land use conditions that have degraded these wetlands are removed, and restoration actions are implemented to enhance wetland function (Parametrix 2000b).

3.2 STREAMS

Impacts to streams resulting from Master Plan Update improvements include filling approximately 980 ft of Miller Creek (Figure 3.2-1). Filling a portion of Miller Creek to accommodate the runway embankment and road relocations would result in loss of surface water conveyance that must be replaced through mitigation (see Section 5.2). The section of Miller Creek to be relocated, adjacent to the Vacca Farm site, is an artificial (ditched) stream channel. The natural stream was moved to its present location and constructed as a straight channel to improve the area for farming.

3.3 FLOODPLAINS

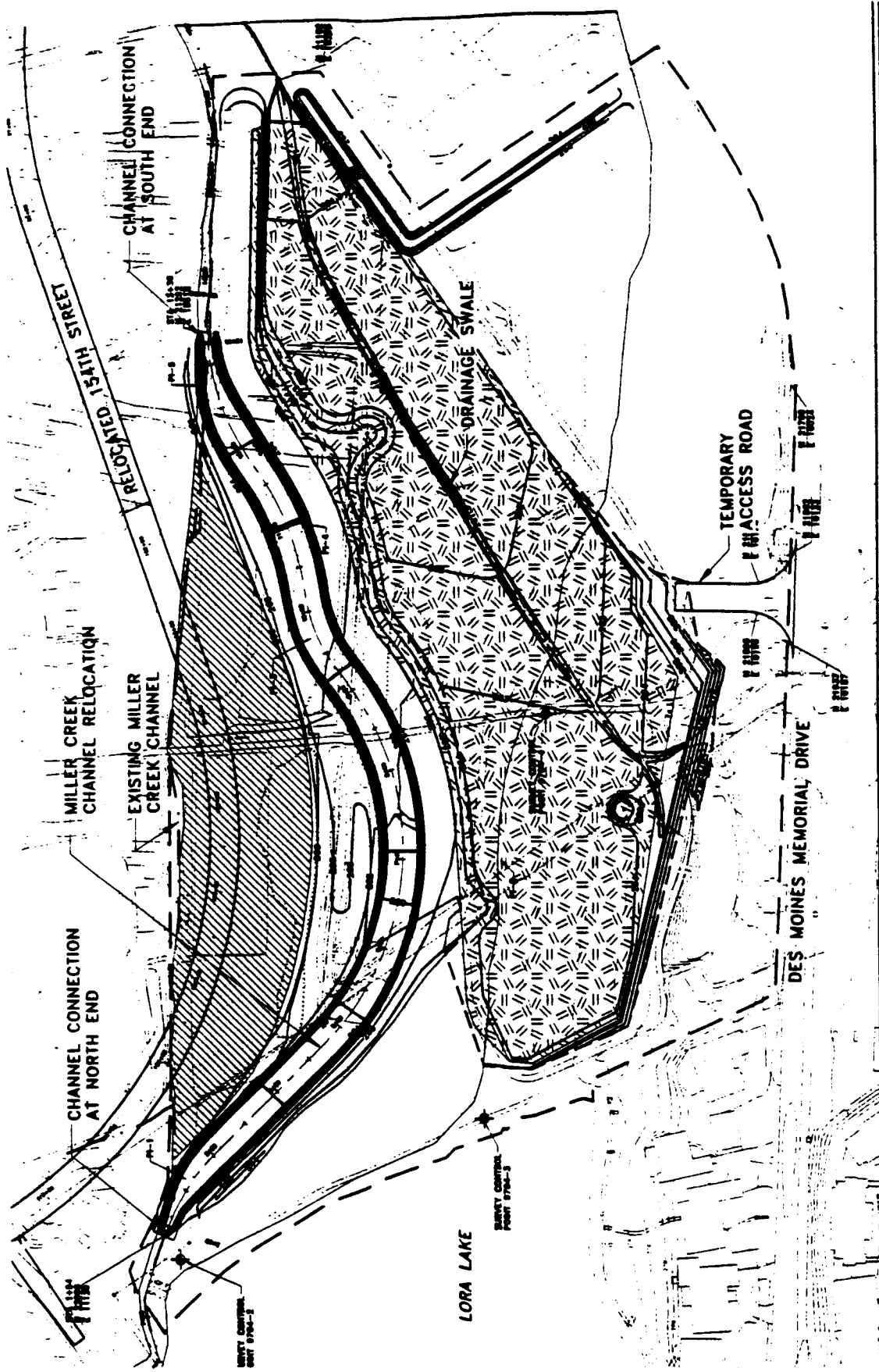
Fill for the proposed Master Plan Update improvements would result in the loss of approximately 5.24 acre-ft of floodplain storage where the segment of Miller Creek will be relocated (see Figures 1.3-2 and 3.2-1). Without mitigation, encroachment on the floodplain would result in loss of flood storage capacity and potential increases in flooding in downstream areas.

Flooding impacts in the Miller Creek basin as a result of the project are unlikely because required mitigation will include adherence to floodplain development standards and floodway management requirements of FEMA, FAA, Ecology, King County, and the City of SeaTac. Floodplain development standards prohibit any reduction in the 100-yr floodplain or base flood storage volume. Compensatory mitigation is required for any proposed filling of the 100-yr floodplain so as to achieve no net loss in flood storage capacity.






Temporary floodplain impacts during construction could include temporary fill for construction access roads and construction in the floodplain as floodplain and wetland mitigation plans are implemented. Since construction would occur during the dry season when the probability of a significant flood is very low, this potential impact is not significant.

3.4 DRAINAGE CHANNELS

Construction of the runway embankment will fill approximately 1,290 ft of three drainage channels near 12th Avenue (Figure 3.4-1) and portions of an agricultural drainage channel at the Vacca Farm site. Portions of Channels A, W, and B will be filled to accommodate the embankment for the third runway (see Figure 3.4-1). These channels do not contain fish habitat. Their primary function is to convey roadside runoff and seepage flow from the hill slopes to the riparian wetlands adjacent to Miller Creek. Without mitigation, filling these channels could result in reduced base flows reaching Miller Creek; however, mitigation actions to reroute seepage and stormwater flow to the riparian wetlands will continue to provide comparable base flow to the stream. Because appropriate mitigation actions will be implemented (see Section 5.2.3), no impacts to Miller Creek will occur from filling these drainage channels.



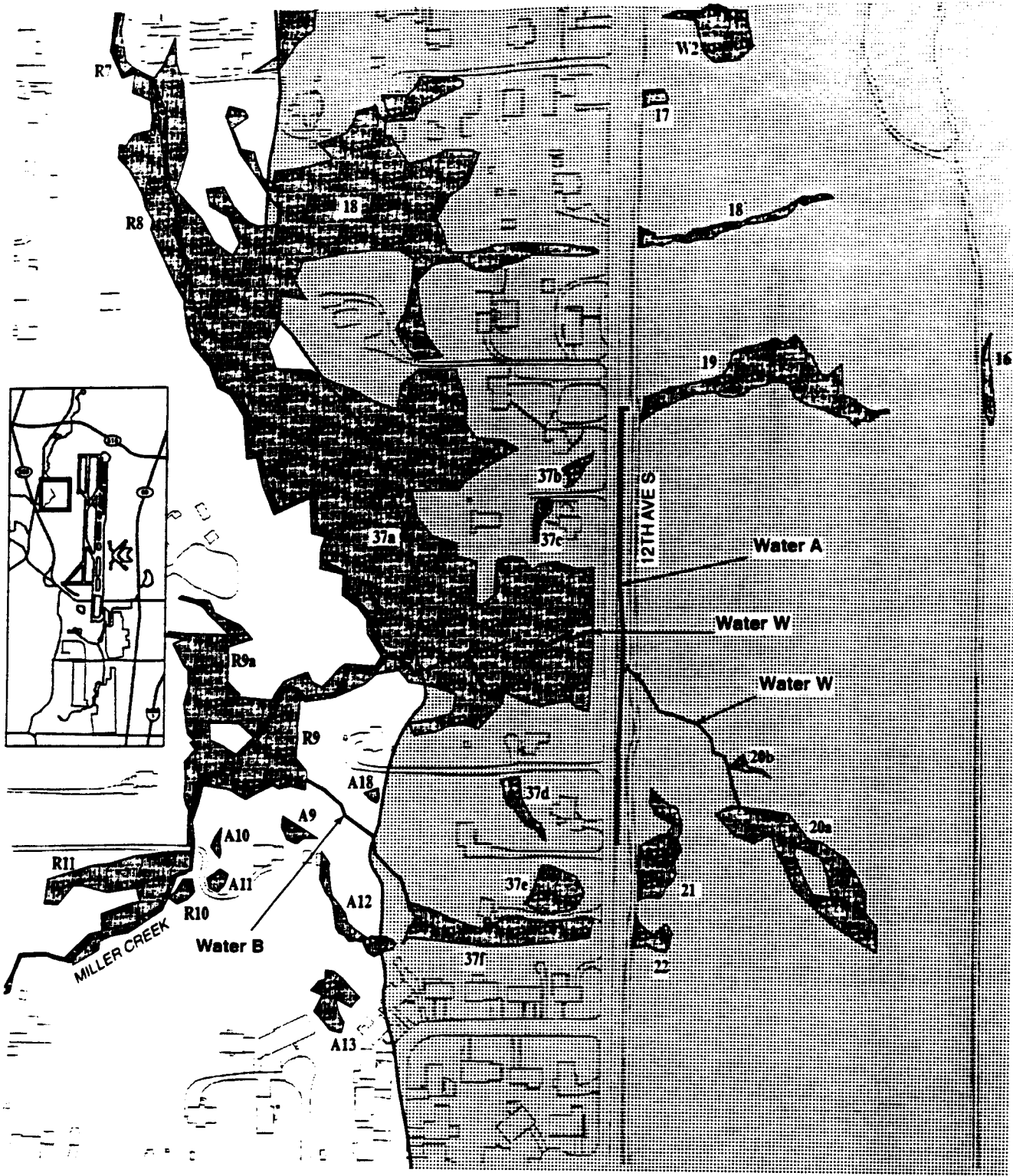
**Figure 3.2-1
Miller Creek
Relocation and Floodplain
Grading at the Vacca Farm Site**

	Existing Floodplain	(Elevation ±284.5)
	Impacted Floodplain	8,455 c.y. (5.24 ac-ft.)
	Floodplain Excavation	9,589 c.y. (5.94 ac-ft.)
	Vacca Farm Site	
	Proposed Grade	

FILE: 29720333-1
DATE: 11/03/00



0 75 150
Scale in Feet



Port of Seattle/Natural Resource Mitigation Plan/556-2912-001/01(03) 12/00 (K)

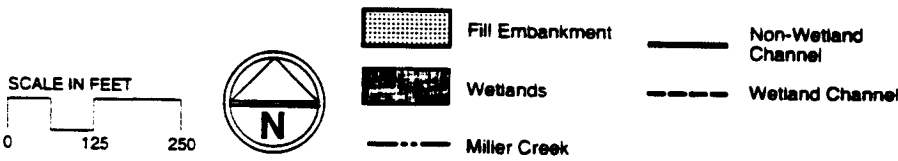


Figure 3.4-1
Location of Drainage
Channel Impacts in
the Miller Creek Basin

A drainage ditch located in the Vacca Farm site (see Figure 2.1-4) parallels Miller Creek for approximately 800 ft. The ditch, which is part of Wetland A1, provides positive drainage for the adjacent farmland, connecting to Miller Creek near South 156th Way. A portion of the channel (approximately 400 ft) would be restored to natural wetland grades and vegetation.

3.5 WATER QUANTITY AND WATER QUALITY

The permanent activities associated with implementation of the Master Plan Update improvements will include grading, filling, paving new streets and runways, and constructing new buildings. These improvements would increase impervious surface areas in the Miller Creek and Des Moines Creek watersheds. Details describing stormwater quality and quantity can be found in Section 6.

Additional impervious surfaces could further increase stormwater runoff rates and volumes, and pollutant loads to the receiving streams. Unless mitigated, changes in runoff would be expected to increase flooding and erosion, and would degrade instream habitat and water quality in Miller Creek downstream of stormwater inputs from the improved areas. The impervious surface areas could reduce the groundwater recharge occurring in the development footprints, resulting in less groundwater seepage during low-flow periods.

Operational impacts to water quality from fuel spills that could occur where fuel is routinely handled are routed to the IWS by an established drainage system. Such spills do not enter the stormwater system and thus do not discharge to wetlands, streams, or other surface waters. Emergency fuel spills that occur outside the fuel handling areas could enter the stormwater drainage system, where they can be controlled and treated through emergency actions.

In the Miller Creek Basin, Master Plan Update improvement projects will result in a net increase of 105.6 acres⁴ of impervious surface area, increasing the overall impervious area in the basin by about 1 percent above the existing baseline condition (about 23 percent of impervious surface [Parametrix 1999]). In the Walker Creek Basin, Master Plan Update improvements will result in an increase of 6.2 acres. In the Des Moines Creek Basin, Master Plan Update improvements will result in an increase of 128.2 acres of impervious surface, increasing the overall impervious area in the basin by about 4 percent above the existing base condition (approximately 32 percent impervious [Parametrix 1999]). A total of 417 acres will drain to the IWS under future conditions.

The new impervious surfaces could increase stormwater runoff rates (FAA 1996) and volumes. Unless mitigated, changes in runoff would be expected to increase flooding and erosion and would degrade instream habitat and water quality in Des Moines and Miller Creeks downstream of stormwater inputs from the improved areas. Chinook salmon critical habitat in the estuaries of Miller and Des Moines Creeks will not be directly altered by runoff from new impervious surfaces in the Master Plan Update. In addition, existing hydrologic impacts from existing impervious surfaces will be mitigated.

⁴ The net change in impervious area includes a reduction of approximately 50 acres of impervious surfaces (streets, driveways, and rooftops) that will result when existing houses and streets are removed in the acquisition area. Demolition in these areas is ongoing and is expected to be completed by 2002.

The impacts of these actions are further discussed in the project EIS, and in the *Comprehensive Stormwater Management Plan* (Parametrix 2000a). Without the proposed mitigation identified in Section 6.1 of this report, this new impervious surface could cause increased flooding, erosion, and habitat and water quality degradation in the Miller and Des Moines Creek watersheds. The *Preliminary Comprehensive Stormwater Management Plan* summarizes the 1994 base watershed drainage area conditions and future conditions for Miller Creek and Des Moines Creek (Parametrix 1999).

4. MITIGATION, MONITORING, MAINTENANCE, AND CONTINGENCY OVERVIEW

This chapter provides an overview of the mitigation, performance monitoring, maintenance, and contingencies actions incorporated into the Master Plan Update to mitigate adverse project impacts to wetlands, streams, floodplains, and drainage channels. In addition, the Port has made extensive efforts throughout the Master Plan Update planning process to avoid, minimize, and rectify, as well as compensate for, adverse impacts. Table 4.1-1 summarizes the comprehensive approach that the Port has taken to avoid, minimize, rectify, and compensate for impacts to wetlands and aquatic resources (Figures 4.1-1 and 4.1-2). Compensatory mitigation projects are summarized in Table 4.1-2, and are the focus of this plan.

The mitigation plan focuses on those compensatory mitigation actions proposed to replace wetland and stream functions impacted by the project (Parametrix 2000b). Thus, key elements of the compensatory mitigation plan are targeted at restoring functions in-basin and include sediment and nutrient retention (water quality), organic carbon production and export, surface water storage (flood water detention and storage), and aquatic habitat functions (e.g., instream aquatic habitat and riparian habitat).

On-site (i.e., in-basin) mitigation actions are summarized in this chapter (Section 4.1.1), and described in detail in Chapter 5 (for aquatic habitat, floodplain, stream, and wetland restoration) and Chapter 6 (for water quality and water quantity). The off-site wetland mitigation is summarized in this chapter (Section 4.1.2), and described in detail in Chapter 7. A description of the overall functional replacement resulting from the mitigation projects is provided in Section 4.1.3.

The Port's mitigation plans include enforceable performance standards and a long-term monitoring plan, which are described in Section 4.2. Monitoring and evaluation of the projects against these performance standards will allow the success of the mitigation projects to be evaluated by the Port and regulatory agencies and provide assurance that the ecological benefits of the mitigation are ultimately achieved. The monitoring section discusses the adaptive management approach that the Port will use to evaluate performance of the mitigation site and implement contingency measures if performance standards are not met. In addition, Section 4.2 summarizes the monitoring methods to evaluate hydrology, vegetation and wildlife habitat on the mitigation sites, the monitoring and control of hazard wildlife (Port of Seattle 2000), and an integrated weed management strategy for managing invasive non-native plant species.

4.1 MITIGATION

The recommended preference for selecting wetland mitigation sites in Washington is as follows: (1) on-site and in-kind; (2) off-site, within the watershed, and in-kind; (3) off-site, out of the watershed, and in-kind; and (4) off-site, out of the watershed, and out-of-kind (Ecology 1990). The Port's proposed mitigation for wetland impacts has followed these recommendations where possible. Therefore, most mitigation for impacts to wetland function is on-site and in-kind in the Miller and Des Moines Creek basins.

Table 4.1-1. Summary of mitigation actions and their relation to National Environmental Policy Act, State Environmental Policy Act, and Clean Water Act mitigation sequencing requirements.

Mitigation Requirement	Proposed Mitigation Action
New Third Runway	
Avoid the impact by not taking a certain action or parts of an action.	Avoid fill in wetlands and Miller Creek by designing the runway to meet the minimum operational, engineering, safety, and maintenance standards. Locate, where feasible, permanent stormwater detention ponds in uplands. Avoid excavation within 50 ft of Category II and III wetlands in Borrow Area 3. Avoid wetlands in Borrow Area 1 where practical.
Minimize the impact by limiting the degree or magnitude of the action.	Construct retaining walls at the northwest end of the runway to reduce impacts to Miller Creek and Category II wetlands (Wetlands 8, 9, and A1) located at the north end of the project. Install a retaining wall near the west-central portion of the embankment to reduce impacts to Category II Wetlands 18 and 37 and avoid relocating a second segment of Miller Creek. Place a retaining wall near the southwest end of the runway to reduce impact to a Category II wetland (Wetland 44). Design Borrow Areas 1 and 3 with a 150- to 200-ft setback from Des Moines Creek to minimize potential impact to the stream and its buffers. Implement stormwater pollution prevention plans (SWPPPs) prior to any construction project.
Rectify the impact by restoring the affected environment.	Remove temporary stormwater management facilities located in wetlands following construction. These disturbed areas will be restored to pre-construction conditions
Reduce the impact over time by preservation and maintenance actions during the life of the action.	Establish and enhance a 100-ft average (minimum 50-ft) forested buffer on both banks of Miller Creek to reduce potential construction and operational impacts to riparian wetlands and aquatic resources. Maintain hydrology to wetlands by directing seepage water from the embankment to wetlands downslope of the embankment. Provide water quantity and water quality mitigation to protect aquatic habitat in Miller Creek from stormwater impacts during operation.
Compensate for the impact by replacing, enhancing, or providing substitute resources.	Restore the Vacca Farm wetland/floodplain area, including creating new floodplain, restoring wetland hydrology and vegetation, and providing protective buffers. Restore and enhance Miller Creek instream habitat in the Vacca Farm area. Restore natural channel morphology to a ditched and channelized reach of the stream. Enhance instream habitat and place large woody debris in Miller Creek and enhance adjacent riparian buffers between Vacca Farm and Des Moines Memorial Drive. Enhance wetlands along Miller Creek within the 100-ft buffer by restoring native vegetation and removing invasive non-native species. Construct replacement drainage channels west of the embankment to replace filled drainage channels.

Table 4.1-1. Summary of mitigation actions and their relation to National Environmental Policy Act, State Environmental Policy Act, and Clean Water Act mitigation sequencing requirements (continued).

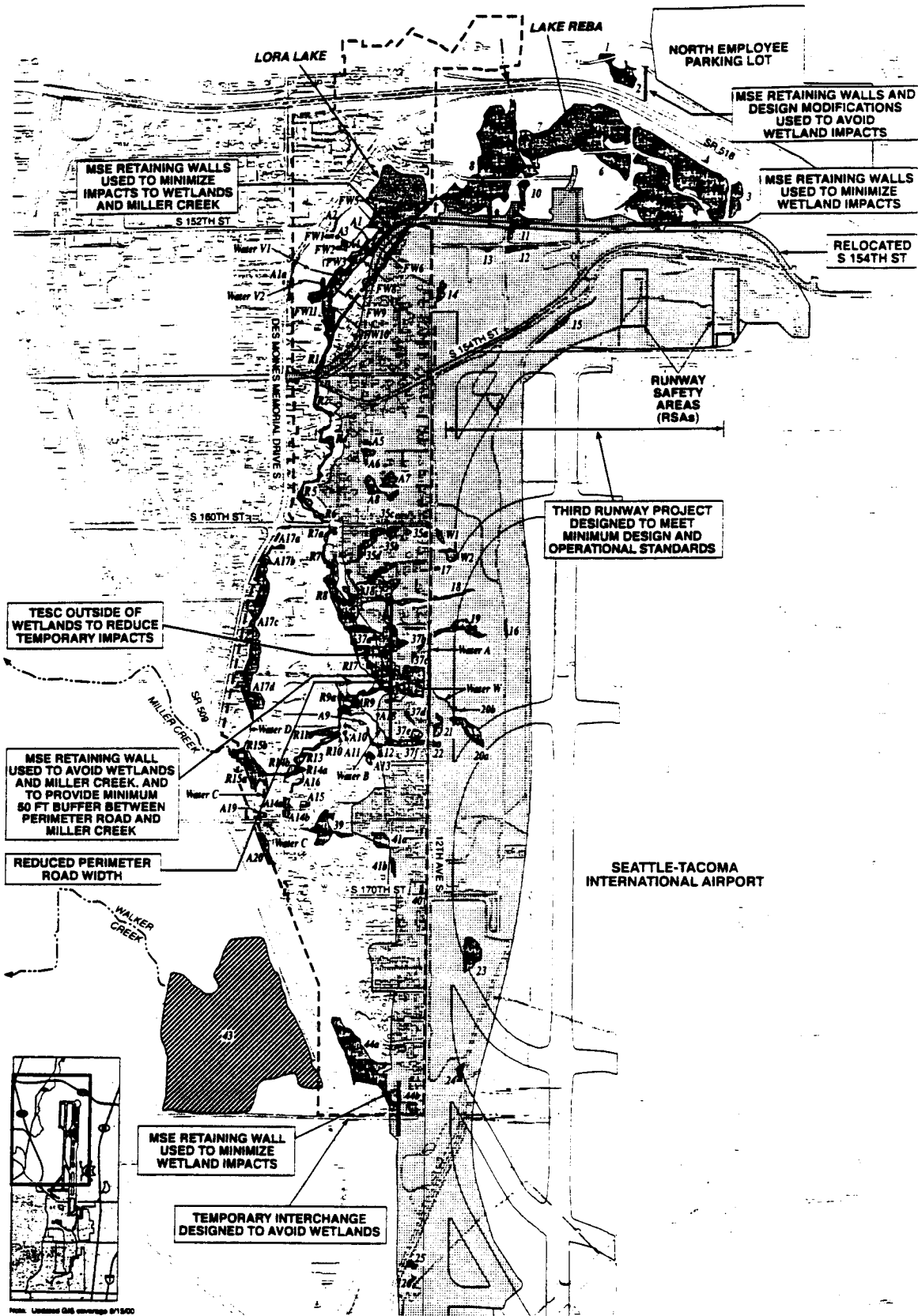
Mitigation Requirement	Proposed Mitigation Action
Compensate for the impact by replacing, enhancing, or providing substitute resources (con't).	<p>Restore wetlands on the Tyee Valley Golf Course including restoring wetland vegetation to reduce wildlife hazards and improve water quality.</p> <p>Enhance aquatic habitat in Des Moines Creek by restoring a 100-ft wide forest/shrub buffer along the stream between the Northwest Ponds and the proposed SR 509 right-of-way (ROW).</p> <p>Provide a \$300,000 trust fund to enhance fisheries habitat in Miller Creek and Des Moines Creek.</p> <p>Create replacement wetlands at an off-site location for the loss of wildlife habitat within 10,000 ft of the airport runways.</p> <p>Monitor mitigation projects for compliance with performance standards and other permit conditions.</p> <p>Monitor stormwater runoff for compliance with National Pollutant Discharge Elimination System (NPDES) requirements.</p> <p>Monitor remaining wetlands downslope of the new embankment (i.e., between the embankment and Miller Creek) for indirect impacts to wetland hydrology.</p>
Runway Safety Areas	
Avoid the impact by not taking a certain action or parts of an action.	Construct retaining walls to support a relocated South 154 th Street and avoid permanent fill in Wetlands 3 and 4.
Minimize the impact by limiting the degree or magnitude of the action.	Construct retaining walls to support a relocated South 154 th Street and reduce permanent fill and minimize temporary impacts in Wetland 5. Implement SWPPPs prior to any construction project.
Rectify the impact by restoring the affected environment.	Restore wetland areas temporarily impacted by required temporary erosion and sediment control facilities.
Reduce the impact over time by preservation and maintenance actions during the life of the action.	Provide water quantity and water quality mitigation to protect wetlands and other receiving waters from stormwater impacts during operation.
Compensate for the impact by replacing, enhancing, or providing substitute resources.	Restore the Vacca Farm wetland/floodplain area to provide hydrologic and water quality functions. Create replacement wetlands for wildlife habitat (greater than 10,000 ft from the airport runways at the Auburn site).
Monitor the impact and take appropriate corrective actions.	Monitor remaining wetlands for indirect impacts to hydrology. Monitor mitigation projects for compliance with performance standards and other permit conditions. Monitor stormwater runoff for compliance with NPDES requirements.
South Aviation Support Area	
Avoid the impact by not taking a certain action or parts of an action.	Design the SASA footprint to avoid relocation of Des Moines Creek. Temporary impacts to Des Moines Creek and Wetland 52 are not anticipated.

Table 4.1-1. Summary of mitigation actions and their relation to National Environmental Policy Act, State Environmental Policy Act, and Clean Water Act mitigation sequencing requirements (continued).

Mitigation Requirement	Proposed Mitigation Action
Minimize the impact by limiting the degree or magnitude of the action.	Design the SASA to avoid direct impacts to forested wetland (Wetland 52) that provides groundwater discharge functions.
Reduce the impact over time by preservation and maintenance actions during the life of the action.	Design water quantity and water quality mitigation to protect wetlands from stormwater impacts.
Rectify the impact by restoring the affected environment.	Restore potential temporary impacts to Des Moines Creek and Wetland 52.
Compensate for the impact by replacing, enhancing, or providing substitute resources.	Restore wetlands on the Tyee Valley Golf Course to provide water quality and hydrologic benefits to replace lost wetland functions. Construct replacement wetlands for wildlife habitat (greater than 10,000 ft from the airport runways at the Auburn site). Enhance and restore a 100-ft-wide forest/shrub buffer along Des Moines Creek to enhance aquatic habitat. Provide a trust fund for enhancement of fisheries habitat of Des Moines Creek.
Monitor the impact and take appropriate corrective actions.	Monitor Wetland 52 for indirect impacts to wetland hydrology. Monitor mitigation projects for compliance with performance standards and other permit conditions. Monitor stormwater runoff for compliance with NPDES requirements.
On-site Borrow Source Areas	
Avoid the impact by not taking a certain action or parts of an action.	Redesign development areas within Borrow Areas 1 and 3 to avoid excavation of twelve wetlands (Wetlands B1, B4, B5, B6, B7, B9, B10, B15a, B15b, 29, 30, and 48).
Minimize the impact by limiting the degree or magnitude of the action.	Establish a 150- to 200-ft buffer between Borrow Area 1 and Des Moines Creek to avoid impacts to stream hydrology and riparian buffers. Follow a Temporary Erosion and Sediment Control Plan (TESCP) to eliminate siltation reaching wetlands or Des Moines Creek from excavation activities. Establish final surface grades in Borrow Area 1, and construct interceptor swale system in Borrow Area 3, to direct surface water runoff and groundwater seepage to wetlands near borrow areas, and minimize and avoid indirect hydrology impacts.
Reduce the impact over time by preservation and maintenance actions during the life of the action.	Maintain Best Management Practices (BMPs) throughout the operating period to ensure adjacent wetlands will be protected from adverse construction-related activities.
Compensate for the impact by replacing, enhancing, or providing substitute resources.	Restore wetlands on the Tyee Valley Golf Course to compensate for water quality and hydrologic support functions impacted in the Des Moines Creek basin. Enhance a 100-ft-wide forest/shrub buffer along Des Moines Creek to enhance aquatic habitat. Provide a trust fund for enhancement of fisheries habitat of Des Moines Creek.
Monitor the impact and take appropriate corrective actions.	Monitor Wetlands B1, B4, B5, B6, B7, B9, B10, B15a, B15b 29, and 30 and 48 for potential indirect impacts to wetland hydrology from excavation activities. Monitor stormwater runoff and TESC for compliance with NPDES requirements.

NEPA = National Environmental Policy Act

SEPA = State Environmental Policy Act



Note: Unfilled GIS coverage 0/1500

Part of Seattle Natural Resources Management Plan 986-2912-001(01)(02) 11/02 (R)

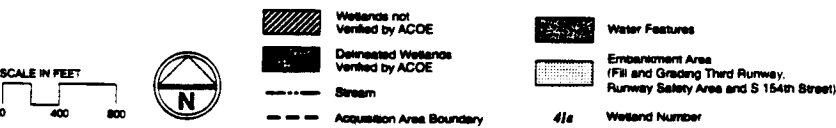
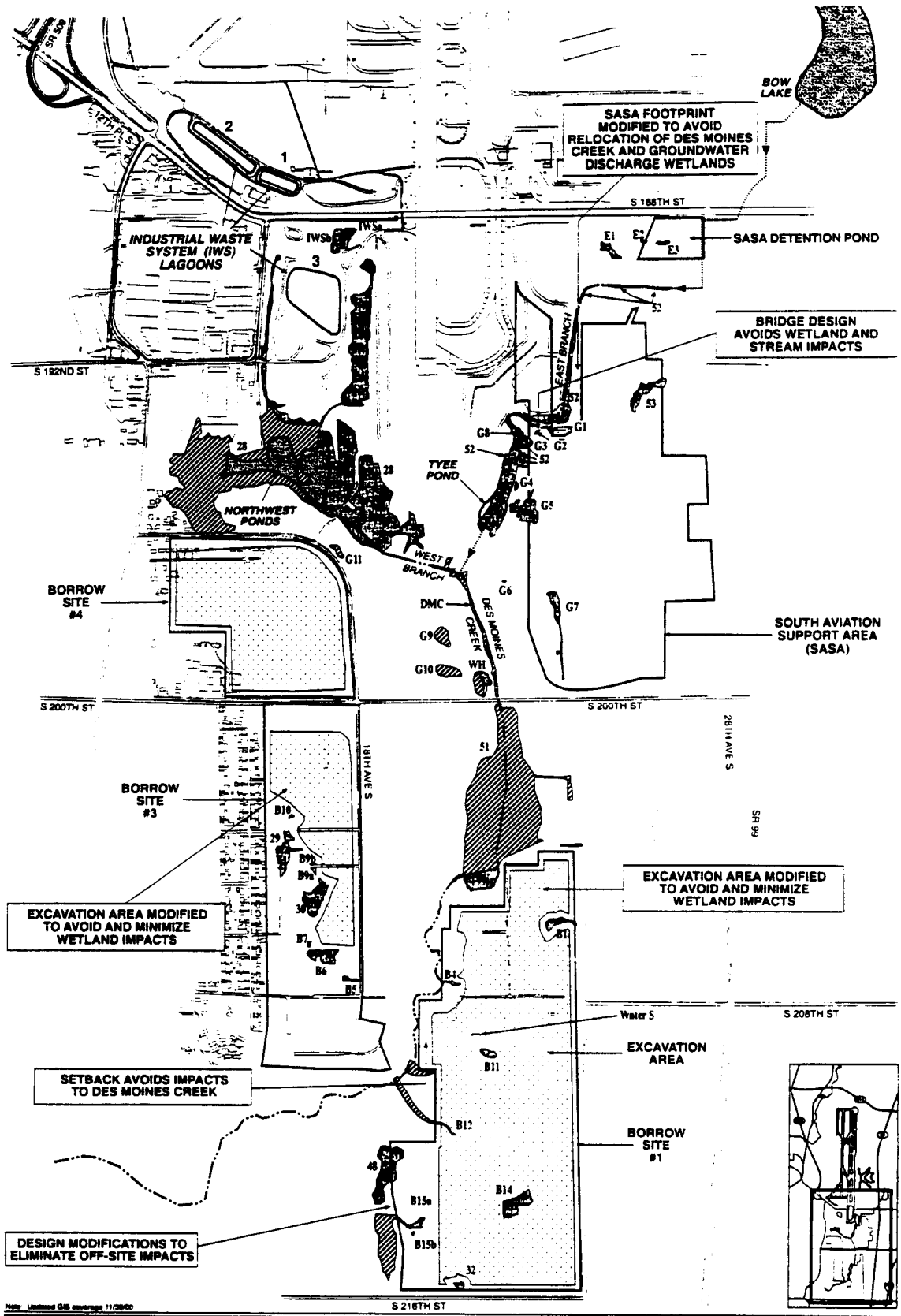


Figure 4.1-1
Avoidance of Wetland and Stream Impacts in the Miller Creek Basin



Note: Limited G6 coverage 11/20/00
 Part of Seattle-Natural Resource Integration Plan/066-2812-001/01/03/ 1200 (R)

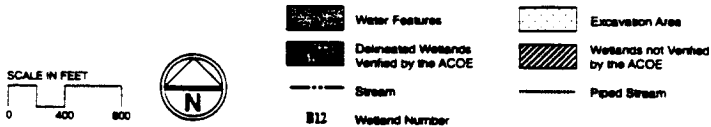


Figure 4.1-2
 Avoidance of Wetland and Stream Impacts in the Des Moines Creek Basin

Table 4.1-2. Summary of compensatory mitigation (on- and off-site) for watershed, wetland, and stream impacts at Seattle-Tacoma International Airport.

Description of Impact	Mitigation Action	Explanation/Comment
On-Site Mitigation¹		
Permanent Impacts		
Fill approximately 980 linear ft of Miller Creek channel to accommodate third runway embankment.	Relocate approximately 1,080 ft of Miller Creek channel.	Channel relocation will enhance aquatic habitat by providing stream buffers, and instream habitat features, and increase channel length by approximately 100 ft. Establish a buffer around the channel relocation project with native trees and shrubs. (This buffer extends into the floodplain area.)
Fill drainage channels to accommodate third runway embankment.	Create new permanent drainage channels and establish protective buffers.	Create approximately 1,290 ft of new permanent drainage channel(s) with associated buffer habitat.
Fill approximately 8,500 cy of Miller Creek floodplain to accommodate third runway embankment and South 154 th Street relocation.	Replace lost floodplain.	Excavate approximately 9,600 cy to achieve storage of 5.94 acre-ft from the Vacca Farm site, providing an excess of 0.7 acre-ft of floodwater storage.
Impact approximately 18.37 acres of wetland during construction of the third runway embankment and other construction-related projects.	Restore Vacca Farm to historic floodplain shrub wetland.	Approximately 9.0 acres of prior converted cropland, farmed wetland, and existing low quality wetlands will be graded and planted with native trees, shrubs, and emergent species (Refer to Table 5.1-1 in Chapter 5). Restoration of the area will stabilize soils, improve water quality, and enhance Miller Creek habitat. It will reduce wildlife habitat attractants and conform to FAA mandates regarding wildlife attractants for airport safety. Remove bulkheads and restore 25-ft buffer around Lora Lake. Restoration of entire Vacca Farm site will provide approximately 17 acres of enhanced stream habitat, floodplain wetlands, aquatic habitat in Lora Lake, and buffers (Refer to Table 5.1-1 in Chapter 5).
	Establish a buffer between the floodplain enhancement area and Des Moines Memorial Drive.	The buffer will be established and enhanced by planting native upland trees and shrubs to provide approximately 1.5 acres of upland buffer. Enhance approximately 7.4 acres of wetlands along Miller Creek by removing structures and restoring native wetland vegetation (Table 4.1-3).

Table 4.1-2. Summary of compensatory mitigation (on- and off-site) for watershed, wetland, and stream impacts at Seattle-Tacoma International Airport (continued).

Description of Impact	Mitigation Action	Explanation/Comment
	Restore wetlands on the Tyee Valley Golf Course.	Plant approximately 4.5 acres of historic peat wetlands in the Tyee Valley Golf Course Mitigation Area and 1.0 acre of wetland in the west branch Des Moines Creek buffer with native shrub communities (see Table 4.1-3). Plant native shrubs in approximately 1.6 acres of buffer in the Tyee Valley Golf Course mitigation area and approximately 3.4 acres in the west branch Des Moines Creek buffer. These enhancement will be coordinated with Des Moines Creek Basin Committee planned RDF. The enhancement and RDF will improve hydrologic functions of the watershed, reduce wildlife attractants near the airfield, and restore a peat wetland.
<u>Temporary Impacts</u>¹		
Construct temporary stormwater management ponds and other construction impacts, which may impact up to 2.05 acres of wetland.	Restore wetland areas after construction is complete.	Wetlands that will be temporarily filled or disturbed will be restored. Restoration will include establishing pre-disturbance topography and planting with native shrub vegetation.
<u>Indirect and Cumulative Impacts</u>¹		
Filled wetlands near Miller Creek reduce aquatic habitat value of the stream.	Establish and enhance buffers along Miller Creek corridor between South 156 th Street and Des Moines Memorial Drive. Establish a 25-ft buffer around Lora Lake.	Establish a 100-ft buffer (on average) on both sides of Miller Creek; minimum buffer width on the east side of the stream will be 50 ft. These buffers and the enhanced Miller Creek Wetlands will provide approximately 40 acres of riparian buffer habitat (see Table 4.1-3). Approximately 0.60 acre of buffer around Lora Lake will be converted from lawn to native wetland and upland shrub vegetation (refer to Table 5.1-1 in Chapter 5)..
Additional development in the watersheds could result in additional cumulative impacts.	Participate in developing and implementing Miller Creek and Des Moines Creek basin plans.	These planning processes will identify effective, long-term solutions to restore additional fish habitat to Miller and Des Moines Creeks. The Port will contribute both staffing resources and funds, and work with other cooperating jurisdictions to plan and implement appropriate watershed restoration projects.

Table 4.1-2. Summary of compensatory mitigation (on- and off-site) for watershed, wetland, and stream impacts at Seattle-Tacoma International Airport (continued).

Description of Impact	Mitigation Action	Explanation/Comment
The runway fill or borrow area excavation may eliminate water sources that contribute to remaining wetlands down slope of the runway.	Design internal drainage and conveyance channels. Monitor wetlands adjacent to the third runway embankment and borrow areas.	Subsurface and surface replacement channels will continue to collect and distribute groundwater currently surfacing near 12 th Avenue South to Miller Creek and associated wetlands. Surface drainage patterns and conveyance swales will be designed to collect and distribute groundwater seepage and surface runoff to wetlands downslope of the borrow areas. Wetlands subject to potential indirect impacts will be monitored to determine if unmitigated indirect impacts have occurred. If significant new wetland impacts are verified, corrective actions will be implemented.
Off-Site Mitigation		
Permanent Impacts		
Loss of approximately 18.37 acres of wetland wildlife (avian) habitat.	Replace high quality wetland and avian habitat functions off-site at an overall ratio of 2:1.	Due to conflicts with avian habitat and aviation safety concerns, new wetlands habitat will be created at a 67-acre site in Auburn, Washington. This wetland creation will increase overall avian and other wildlife use and diversity in an area that will not compromise aviation safety.

¹ All mitigation areas (including, but not limited to, streams, wetlands, buffers, and floodplains) located within 10,000 ft of a runway shall be subject to the provisions of the Port's *Wildlife Hazard Management Plan* (USDA 2000) for the management of wildlife and wildlife attractant areas.

Table 4.1-3. Summary of wetland mitigation credit for Seattle-Tacoma International Airport Master Plan Update improvements

Mitigation	Mitigation Area (acres)	Mitigation Credit
In-Basin		
<u>Wetland Restoration</u> – Credit ratio 1:1		
Vacca Farm (prior converted cropland and other upland)	6.60	6.60
<u>Wetland Enhancement</u> – Credit ratio 1:2		
Vacca Farm (Farmed Wetland, Other Wetlands, Lora Lake)	5.70	2.85
Wetlands in Miller Creek Wetland and Riparian Buffer	7.40	3.70
Tyee Valley Golf Course	4.50	2.25
Wetland in Des Moines Creek Buffer	1.01	0.51
Subtotal	25.21	12.61
<u>Buffer Enhancement</u> - Credit ratio 1:5		
Miller Creek Buffer, South of Vacca Farm	32.00	6.40
Vacca Farm	4.58	0.92
Lora Lake	0.27	0.05
Tyee Valley Golf Course Mitigation Area Buffer	1.57	0.31
West Branch Des Moines Creek Buffer	3.38	0.68
Subtotal	41.80	8.36
Total In-Basin Mitigation^{1, 2}	67.01	20.97
Out-of-Basin		
<u>Wetland Creation³</u> - Credit ratio 1:1		
Forested (17.20 ac), shrub (6.0 ac), emergent (6.20 ac), and open water (0.60ac)	29.98	29.98
Wetland Enhancement - Credit ratio 1:2	19.50	9.75
Buffer Enhancement - Credit ratio 1:5	15.90	3.18
Total Out-of-Basin Mitigation	65.38	42.93
Total Mitigation⁴	134.39	63.90

¹ Mitigation credit has not been assigned for relocating a portion of Miller Creek channel, instream enhancement projects, drainage channel replacement, Des Moines Creek buffer enhancement, or \$300,000 trust fund for watershed restoration.

² Mitigation areas in the Des Moines and Miller Creek watersheds are 10.46 acres and 56.55 acres respectively; in-basin mitigation area divided by wetland impact (18.37 acres) provides 3:1 aerial replacement ratio.

³ Based on maps of hydric soils, mitigation can be also characterized as restoration.

⁴ Total mitigation area divided by wetland impact (18.37 acres) provides a 7.3:1 aerial replacement ratio; total mitigation credit divided by wetland impact (18.37) provides a 3.5:1 replacement ratio.

However, all mitigation areas (including but not limited to wetlands, streams, buffers, and floodplains) and other lands located within 10,000 ft of a runway are subject to the provisions of the Port's WHMP (USDA 2000) for management of wildlife and wildlife attractants (FAA Advisory Circular 150/5200-33). No open-water habitat can be created within 10,000 ft of the airfield as part of this mitigation plan. On-site mitigation is planned to reduce certain existing wildlife hazards to comply with FAA mandates regarding wildlife attractants near airports. Mitigation for wildlife habitat (bird and small mammals), is provided off-site. The off-site mitigation is designed to provide a large, high-quality, diverse wetland system and is located in the City of Auburn. At this site, habitat mitigation can be provided that is consistent with the FAA Record of Decision (1997) and Advisory Circular 150/5200-33 regarding wildlife attractants near airports.

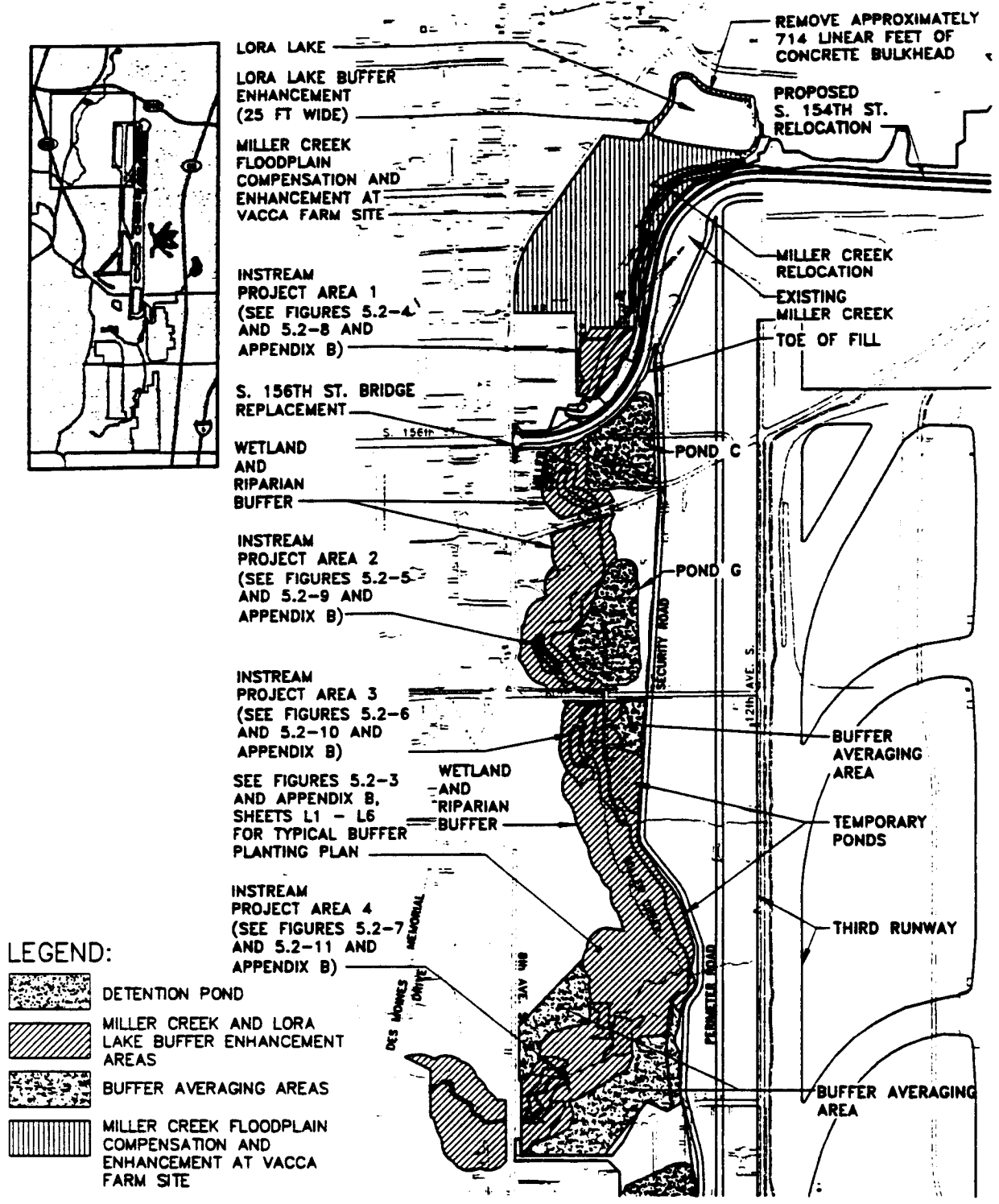
4.1.1 On-Site In-Basin Mitigation

Following the recommended preference for on-site, in-basin mitigation, a number of on-site mitigation elements are proposed to compensate for Master Plan Update improvements affecting wetlands, hydrology, water quality, and aquatic habitat in the Miller and Des Moines Creek basins. Mitigation projects in Miller and Des Moines Creek basins are designed to replace all lost wetland functions with the exception of avian habitat. In-basin mitigation is also directed toward removing certain existing land use conditions that, over time, have contributed to degraded wetland and aquatic habitats in these basins. The mitigation projects designed for the Master Plan Update improvements (Figure 4.1-3 and see Table 4.1-2) have been developed in direct response to agency guidelines for in-basin functional mitigation.

4.1.1.1 Miller Creek Basin

The focus of mitigation in the Miller Creek basin is to restore and enhance ecosystem functions to the aquatic/wetland systems along a significant portion of Miller Creek. Mitigation actions in the Miller Creek basin will restore wetland, stream and riparian functions to a 1.4 mile reach, or approximately one third of the entire length of Miller Creek.

The Miller Creek watershed has been modified and habitats degraded by historical and on-going agricultural, residential, commercial, and industrial development. Approximately 80 percent of the watershed has been converted from its original forested condition to residential or commercial land uses (Parametrix 2000a). Increased impervious surfaces have resulted in increased runoff rates and volumes which have contributed to erosion and downcutting in high energy reaches, and increased sedimentation and habitat degradation in low gradient reaches (FAA 1996; KCSWM 1994). Runoff from residential, commercial, and agricultural areas have increased inputs of sediment, nutrients, and pollutants to the stream. Upland and wetland riparian areas adjacent to the stream have been altered from the original forest and/or shrub cover to impervious surfaces, agricultural fields, residential lawns, or ornamental landscaping. Native plant and animal habitats have been reduced in size and fragmented, resulting in a loss of species diversity.



FILE: 291203F_4.1-3
DATE: 11/27/00

0 350 700
SCALE IN 1"=700'



**Figure 4.1-3
Locations of Mitigation
Projects in the
Miller Creek Basin**

The natural channel morphology of Miller Creek has been altered, particularly in reaches above South 160th Street. Extensive areas of the channel have been armored with riprap or retaining walls, and dredged or straightened to protect property adjacent to the stream or to drain land for agricultural uses. For much of its length, Miller Creek lacks connections to adjacent floodplains, floodplain wetlands, or riparian areas due to filling of adjacent wetlands, as well as dredging and straightening the channel to increase conveyance. These changes have resulted in a lack of habitat complexity, a lack of woody debris in the channel, a lack of shading from riparian vegetation, the loss of surface water storage, and degraded water quality and biotic integrity in much of the basin.

To replace functions impacted by the Master Plan Update improvements and to restore and enhance aquatic and wetland functions in the Miller Creek basin, the Port proposes the following specific mitigation:

- Restore *natural channel morphology, habitat complexity, and instream habitat* along an approximately 1.4-mile reach of Miller Creek extending from south of Lora Lake to Des Moines Memorial Drive.
- Restore *floodplain, floodplain wetlands, and riparian areas* along the upper reaches of Miller Creek, and re-integrate floodplains and adjacent wetlands with the stream.
- Restore, replace, and enhance *wetland and aquatic habitat functions* to the currently degraded, lacustrine, stream, floodplain, and riparian wetland system along the upper reaches of Miller Creek.
- *Maintain wetland hydrology and baseflow* function in wetlands adjacent to the embankment fill by providing surface water drainage features to convey groundwater and surface water runoff from the new embankment to downslope wetlands.
- *Restore and enhance wetland and aquatic functions, and protect the long-term viability* of these systems, by establishing native forested buffers around wetlands and aquatic systems from Lora Lake to Des Moines Memorial Drive.
- *Restore habitat connectivity* in the upper reaches of the Miller Creek basin by providing a continuous forested wetland and riparian corridor connecting currently fragmented wetland, aquatic, and riparian habitats between Lora Lake and Des Moines Memorial Drive.

To accomplish these objectives, mitigation projects will be concentrated in two areas along the upper reaches of Miller Creek: (1) Lora Lake and the Vacca Farm and (2) Miller Creek and its riparian zone between Lora Lake and Des Moines Memorial Drive.

In addition to these projects, the Port will establish watershed trust funds to fund local stream restoration projects in the Miller Creek basin.

4.1.1.2 Des Moines Creek Basin

Mitigation projects for the Des Moines Creek basin are designed to mitigate for unavoidable project impacts to wetlands and aquatic resources by restoring wetland and stream functions, and by providing mitigation for potential indirect effects to wetland hydrology. Mitigation actions in the Des Moines Creek basin will increase infiltration adjacent to the stream, reduce pollutant runoff,

increase sediment retention, and improve nutrient cycling functions in the wetland adjacent to Des Moines Creek. To replace functions impacted by Master Plan Update improvements and to restore and enhance aquatic and wetland habitat in the Des Moines basin, the Port proposes the following specific mitigation:

- *Restore and enhance wetland and aquatic habitat* by replacing the existing turfgrass wetland with a native shrub wetland at the Tyee Valley Golf Course adjacent to Des Moines Creek
- *Enhance water quality, fish habitat and restore stream conditions* in Des Moines Creek by establishing a forested buffer along a 870 ft reach of west branch Des Moines Creek
- *Avoid, minimize, and mitigate* potential indirect hydrology impacts to wetlands adjacent to the Borrow Areas by directing groundwater seepage and/or surface water runoff to wetlands near the Borrow Areas

In addition to these projects, the Port will establish watershed trust funds to fund local stream restoration projects in the Des Moines Creek basin.

4.1.1.3 In-basin Stormwater Mitigation

The Port will construct the necessary stormwater conveyance, detention, and treatment facilities to manage runoff from both newly developed project areas and existing airport areas. These facilities will not only mitigate new construction impacts, as required by current stormwater regulations and mitigation goals identified during the environmental review process, but they will also help to reduce flood peaks in these basins to further mitigate the impacts of airport stormwater discharges.

In-basin stormwater facilities will be constructed in Miller, Walker, and Des Moines Creek basins, at 14 separate locations and provide approximately 326 acre-ft of new storage. The following sections describe specific mitigation to reduce stormwater impacts from Master Plan Update improvements. Detailed information on mitigation for stormwater quantity and quality is included in the *Stormwater Management Plan* (Parametrix 2000a).

Stormwater Detention Based on Higher Stormwater Standards

Detention storage provided for Master Plan Update improvement projects will exceed that normally required by local regulations, and result in additional mitigation of stormwater impacts from Master Plan Update improvement project areas, including reduced peak stormwater runoff impacts on Miller, Walker, and Des Moines Creeks.

Reduce Runoff from Existing Airport Areas With Stormwater Detention

To control runoff from areas of the airport developed prior to 1994, stormwater detention will be provided to mitigate existing runoff impacts. Proposed detention facilities on Miller, Walker, and Des Moines Creeks include stormwater detention to mitigate impacts of pre-1994 development. In the retrofit analysis, the pre-development flow rates assumed that existing land cover is 10 percent impervious area, 75 percent forest, and 15 percent grass (also known as the pre-development "target flow regime"). Stormwater detention designs for retrofitting in Miller, Walker, and Des Moines Creeks are based on the Level 2 flow control.

Provide Infiltration at Stormwater Detention Facilities

Further improvements to low stream flows will be achieved by infiltrating stormwater at the detention facilities. Because site conditions must be favorable for infiltration to be feasible, the Port has evaluated infiltration for stormwater detention facility design. Ponds in the Miller Creek Basin will use infiltration.

Water Quality Mitigation

The STIA Master Plan Update improvement projects are not expected to impact existing water quality because (1) the quality of STIA runway stormwater has been shown to be comparable to or better than regional urban stormwater, and (2) in contrast to existing land uses, all Master Plan improvements will be served by BMPs in compliance with the Stormwater Management Manual for Puget Sound (Ecology 1992) (e.g., bioswales, filter strips, wet vaults, infiltration).

Since Miller, Walker, and Des Moines Creeks drain urban watersheds, they have been subject to cumulative impacts of heavy metals, oils, and grease from nearby urban highways; fecal coliform from failing residential septic systems and adjacent farms; suspended solids and litter carried in urban runoff; and increased levels of phosphorus and nitrogen from fertilization of cultivated areas. These impacts are typical of an urban environment supporting an assortment of residential, commercial, and industrial activities. Sources of many of these pollutants will be removed as part of the Master Plan Update improvements within the approximately 258-acre acquisition area. Because actions to mitigate impacts to water quality will be in place, the quality of stormwater runoff in the future will be equal to or better than current stormwater quality. A detailed discussion of water quality benefits and mitigation is included in the *Comprehensive Stormwater Management Plan* (Parametrix 2000a).

4.1.2 Off-Site Mitigation

Off-site mitigation is proposed because FAA regulations prohibit the siting of potential wildlife attractants (including wetland mitigation) within 10,000 ft of active runways. The Port searched for wetland mitigation sites in the Des Moines and Miller Creek watersheds that could be used to provide replacement wildlife habitat; however, these watersheds are almost totally within the 10,000-ft exclusion area for wildlife habitat mitigation. Areas within these two watersheds that are more than 10,000 ft from existing runways were found not to be suitable for mitigation due to their small size, developed nature, forested condition, or the lack of hydrologic conditions necessary to support wetlands.

To mitigate for the loss of wildlife habitat due to the Master Plan Update improvements, the Port will construct wetland mitigation off-site on a 67-acre parcel in the City of Auburn. This wetland mitigation area will replace lost wetland functions at a minimum 2:1 replacement ratio. This mitigation provides the opportunity to create, restore, and enhance high quality, diverse forested, shrub, emergent, and open water wetland habitats and functions to a site where these functions are currently absent or degraded. Approximately 17.2 acres of forest, 6.0 acres of shrub, 6.2 acres of emergent, 0.60 acre of open water, and 19.50 acres of enhanced emergent wetland habitat will be created or restored. Overall habitat functions will be enhanced by providing approximately 11.9 acres of forested buffers around the perimeter of the site and approximately 4.0 acres of upland habitat within the interior portion of the site. Wetland functions in existing wetlands will be

enhanced by replacing non-native pasture grasses with native forested, shrub and emergent wetland plant communities.

4.1.3 Replacement of Functions by the Mitigation Plan

Mitigation for unavoidable impacts to wetlands proposed in this plan meets or exceeds requirements to mitigate for lost wetland area and functions (See Table 4.1-3). In Miller and Des Moines Creek basins, the Port proposes to restore and enhance non-avian habitat wetland functions in 25.21 acres of wetlands and aquatic habitat, providing mitigation for impacts to 18.37 acres. Buffers associated with restored streams and wetlands in the basin will total approximately 42 acres. Out-of-basin mitigation at the Auburn mitigation site will consist of creating approximately 30 acres of new wetlands, enhancing 19.5 acres of existing emergent wetlands, and enhancing approximately 15.9 acres of forest habitat.

Additional mitigation to replace functions will be provided in the form of funding for stream enhancement and provision of extensive buffers and in-basin water quality and water quantity controls on stormwater runoff. These mitigation actions provide further assurance that all wetland functions potentially impacted are replaced, and there is significant ecological restoration of the impacted watersheds.

4.2 MONITORING PLAN AND CONTINGENCY MEASURES

Effective monitoring, adaptive maintenance, and contingency actions are planned to evaluate if performance standards are met, and to correct deficiencies if needed. Monitoring and reporting of monitoring results for agency review and concurrence will assure that appropriate contingency actions are taken, and ecological benefits are ultimately achieved. This section describes the monitoring of mitigation sites that will occur over a 10-year period to verify that each project is meeting established performance standards and permit conditions. The monitoring approach for all mitigation projects is described here. Specific monitoring requirements for individual projects are included in Chapter 5 (on-site) and Chapter 7 (off-site). If monitoring demonstrates that performance standards are not met, then contingency actions will be evaluated and implemented to assure that the desired wetland functions are ultimately provided by the mitigation projects.

4.2.1 Monitoring Approach

The monitoring plan describes steps that the Port will take to ensure that the mitigation projects meet design goals, objectives, performance standards, and permit conditions. Monitoring will be used to evaluate conditions at each mitigation site relevant to mitigation success, including overall site conditions, site hydrology, vegetation, wildlife, invasive species, and when applicable for specific projects, channel morphology and instream habitat features. Measures of factors indicating ecological function (such as percent cover of native vegetation, percent survival of planted stock, channel bed material size distribution, channel profiles, density of large woody debris in streams, and frequency and size of pools in streams) will be used to quantify site conditions and allow comparisons with performance standards.

Performance standards are measured using standard field techniques, and are thus enforceable by permitting agencies. Performance standards developed for the Port's mitigation plan reflect reviews by ACOE and Ecology.

Monitoring results will be used to evaluate appropriate contingency measures in cases where performance standards are not met. Contingency measures will be implemented following an adaptive management approach, described in Section 4.2.2. The adaptive management approach depends on monitoring data to:

- Evaluate the locations and need for contingency measures
- Develop appropriate contingency measures
- Adapt contingency measures as necessary to meet performance standards
- Evaluate the success of contingency measures following implementation

4.2.1.1 Monitoring Period

Monitoring of the mitigation sites includes monitoring before, during, and after mitigation construction. The Port has conducted regular monitoring of the acquisition area during the acquisition and mitigation design phases to ensure that no wetlands or aquatic resources are impacted by nearby construction or survey activities. Pre-construction monitoring includes steps such as ensuring that wetlands and/or stream boundaries are clearly marked or fenced, inspecting sediment and erosion control measures, and regular site inspections to ensure that construction or survey operations are avoiding wetlands and streams. In addition, groundwater hydrology monitoring will be initiated in wetlands near the new embankment and borrow areas prior to project construction to allow the Port to evaluate any potential indirect impacts. This monitoring will allow the Port to detect potential indirect hydrology impacts, and implement appropriate contingency measures to maintain hydrology in these wetlands.

The Port will also monitor all mitigation sites during construction. Construction monitoring is essential to ensure that mitigation designs are implemented according to plans and specifications in this mitigation plan, and in the final construction documents. Construction monitoring will also ensure that construction activities are consistent with federal, state, and local permit conditions. Construction monitoring will include regular and periodic inspections of the project site, regular meetings with contractors, and site visits during implementation of critical design elements (e.g., diverting flows to the new Miller Creek channel). Inspection activities during regular visits will include, for example, verifying that appropriate sediment and erosion control measures are in place, plants are being installed correctly and consistent with the plans, and that habitat features are installed consistent with the plans. If changes to the planting design or plant schedule are required (as a result of new information about site conditions), they will be reviewed and approved by the wetland scientist or landscape architect appointed by the Port prior to implementation. Any modifications that affect the ability of the project to meet performance standards will be presented to ACOE for approval prior to implementation.

Construction monitoring will also ensure that elements of mitigation construction are coordinated with other site activities. Because mitigation construction will often be coordinated with Master

Plan Update improvement construction activities, construction monitoring will also ensure that Master Plan Update construction-related activities do not result in impacts to mitigation sites. For example, mitigation planting zones that are adjacent to Master Plan Update construction sites (e.g., Miller Creek relocation and South 154th Street relocation) will be protected and monitored to ensure that plants installed on the mitigation sites are not damaged or disturbed by Master Plan Update construction.

All mitigation projects will be monitored for at least a 10-year period following completion of mitigation construction and approval of record drawings by the agencies. Monitoring is currently scheduled to take place at a minimum during years 0 (baseline), 1, 2, 3, 5, 7, 9, and 10, and monitoring reports will be submitted to the agencies (i.e., ACOE, Ecology) each year monitoring is conducted.

Baseline monitoring data will be collected following completion of mitigation construction. The baseline monitoring report will include a summary of site conditions immediately following mitigation construction, as well as the documentation of the protocol to be used to monitor the mitigation sites (e.g., sampling methodology, locations of all monitoring wells, photo points, vegetation sampling plots). Post-construction monitoring methods, parameters to be measured, and specific monitoring schedules for each of the mitigation projects are included in this document in the individual sections describing each mitigation project (Chapters 5 and 7).

4.2.1.2 Monitoring Reports

Baseline Monitoring Report

On completion of construction for each mitigation project, record drawings will be submitted to EPA, USFWS, Ecology, and ACOE. Record drawings will document the final design of the mitigation sites, and any minor changes to mitigation plans that may have occurred during construction. For example, record drawings will include the following:

- Final site topography
- Site boundaries and location of perimeter fencing and signs
- Planting plans showing species composition, spacing and sizes, and location of planting zone boundaries
- Photographs taken of the mitigation site from permanent reference points
- Locations of all monitoring sample points and/or transects (e.g., vegetation transects and plots, permanent photo points, groundwater monitoring well locations, staff gauge locations, etc.)

A baseline monitoring report will also be prepared to document initial post-mitigation site conditions for hydrology, wildlife, vegetation, invasive species, channel morphology, and instream habitat features for each mitigation project as they apply. These baseline conditions will allow the Port and agencies to evaluate changes on the mitigation site over time, and progress toward meeting mitigation objectives and final performance standards.

A report including the record drawings of the mitigation site and locations of monitoring sampling locations will be submitted within 60 days of the completion of the final planting for a given mitigation site. The baseline monitoring report will be submitted within 120 days of the completion of the final planting for a given mitigation site.

Post-construction Monitoring Reports and Reporting Schedule

Monitoring of all mitigation sites (including temporary impacts that involve fill or clearing of vegetation in wetlands) will be conducted for a period of not less than 10 years, consistent with the monitoring plans, methods, and schedules described in this document. Regular monitoring periods for post-construction monitoring will be in years 0 (baseline), 1, 2, 3, 5, 7, 9, and 10. Monitoring reports will summarize the monitoring information collected during each monitoring period. Reports will also compare results from each monitoring period to baseline conditions, previous monitoring year results, and performance standards, and discuss any recommended contingency actions. Monitoring reports will be submitted by the end of the year (i.e., December 31st) of each monitoring period, or at a time mutually agreed upon by the Port and agencies. Monitoring schedules specific to each mitigation project are included in the individual project descriptions in Chapter 5 and Chapter 7 of this document.

Reporting of Hazard Wildlife Monitoring Results

In addition to performance monitoring that will be conducted specifically for the mitigation sites, the Port of Seattle conducts regular monitoring as part of the WHMP. Monitoring activities and results regarding hazard wildlife in the area of the mitigation projects will be included as an attachment to the mitigation monitoring reports. The purpose of this attachment will be to document the status of the mitigation projects near the airport with regard to hazard wildlife.

4.2.1.3 Monitoring Methods

Hydrology

Groundwater and/or surface water hydrology will be monitored at mitigation sites for a 10-year period following completion of all mitigation construction. The hydrology in wetlands located adjacent to the runway embankment, SASA, Borrow Area 1, and Borrow Area 3 will also be monitored. The primary purpose of monitoring groundwater levels in mitigation areas is to verify that groundwater, which maintains wetland conditions on most of the mitigation sites, is present and continues to support wetland conditions. The evaluation will include determining that groundwater levels and periods of saturation are sufficient to support the wetland plant communities present on each site. Monitoring wetland hydrology in wetlands adjacent to the Master Plan Update improvements will be completed to verify that indirect impacts to wetland hydrology do not occur, and to implement contingency actions if they are found.

Permanent groundwater monitoring wells will be installed to monitor seasonal groundwater levels at each site. The number and location of monitoring wells will be established following an assessment of post-grading site conditions at each mitigation site. However, well numbers and locations will be sufficient to ensure that groundwater hydrology can be measured in each planting zone, and in all wetlands at each mitigation site. Well locations will be surveyed and included on site base maps.

Final well numbers and locations will be included in the record drawings. All monitoring wells will be installed by a licensed well driller and recorded with Ecology.

Depths to groundwater will be measured monthly during the first 3 years following completion of grading and then seasonally (i.e. four times a year) thereafter. These data will be used to evaluate the depth, frequency, and duration of inundation, and/or soil saturation on the mitigation sites, and determine whether wetland hydrology performance standards are met. These data will also be used to determine appropriate contingency measures if performance standards are not met, and to evaluate adaptive management or maintenance needs.

Groundwater monitoring will also be used to evaluate any potential indirect impacts to wetland hydrology in wetlands between the new third runway embankment and Miller Creek, and wetlands downslope of the borrow areas. Master Plan Update improvements have been designed to avoid and minimize any indirect impacts to wetland hydrology, and hydrology in these wetlands will be monitored to verify that indirect impacts have not occurred.

Surface water levels and/or flows will be monitored at selected mitigation sites where flow rates or the extent, frequency, or duration of inundation are important components of the mitigation (e.g., Miller Creek channel relocation, replacement drainage channels, Auburn open water habitat, Wetland 30 near Borrow Area 3). Surface water levels will be evaluated using staff gages. Surface water depths and/or flow rates will be measured during regular monitoring visits. Flow rates will be measured using depth and velocity methods.

Wetland Indicators

Wetlands at each mitigation site will be evaluated to verify that these areas continue to meet jurisdictional wetland criteria following mitigation. Methods consistent with the ACOE 1987 Manual (Environmental Laboratory 1987) for delineating wetlands will be used to verify that hydric soils, hydrology indicators, and hydrophytic vegetation are present in the wetland areas.

Vegetation

Vegetation monitoring will be used to determine if native plant communities are established in accordance with the specific performance standards for each site, and to provide guidance for the implementation of contingency measures when necessary. A range of variables will be evaluated, including percent survival, canopy cover by strata, height by strata, number of vegetation strata, species composition and richness, evidence of herbivore damage or disease, recruitment (i.e., the number of newly establishing individuals), and canopy cover and number of invasive, non-native species.

Immediately after completion of plant installation, the landscape architect or wetland scientist will inspect the site to evaluate the planted stock for overall health. If necessary, re-planting will be recommended to ensure that the site has been planted according to the plans and specifications. Following this inspection, record drawings will be completed to show the location of the installed plant material, the species composition, density and spacing of plants in each planting zone, and average height of each strata in each zone. Permanent vegetation photo points, sampling plots, and/or transects will be established in the field and shown on the record drawings. Vegetation data will be collected to establish baseline conditions on the monitoring site. Record drawings and

baseline conditions establish a benchmark against which future changes in the vegetation can be compared. The photo points will provide a visual representation of plant cover, species composition, and general health.

The timing of the baseline monitoring will depend on construction schedules, and subsequent monitoring visits will be scheduled such that at least one full growing season occurs between monitoring dates. Vegetation sampling should occur in the late spring or early summer (June through early July). A combination of plot and plotless vegetation sampling techniques will be used following standard vegetation sampling protocols (Kent and Coker 1994). Vegetation sampling plots and/or transects will be located to ensure a representative sample of the entire mitigation site (i.e., in each planting zone, in representative locations throughout the site).

Plant survival is a key indicator of the success of native vegetation establishment and of the maintenance of target densities on the mitigation sites. A minimum survival rate of 80 percent for planted stock (calculated as percent of original individuals planted) will be required for the first 3 years of the monitoring period.

Due to the difficulty in locating and tracking individual plants over time, plant cover rather than survival or density will be evaluated following year 3. After year 3, cover of native species will more accurately reflect the ultimate habitat conditions desired on the mitigation sites. After year 3, performance standards will target a density and/or cover measure so that plant abundance can be evaluated even if plant numbers cannot be accurately estimated.

Natural colonization on the mitigation site is an important measure of the success of the mitigation. Plants that colonize the site (i.e., recruitment) following mitigation construction will be included in several of the variables used in the vegetation monitoring (e.g., density, species composition and richness measures, and percent cover).

Wildlife

Port wildlife managers will monitor the mitigation sites near STIA to determine hazard wildlife use (USDA 2000). Mitigation areas will be monitored according to the Port's WHMP. Information obtained from the hazard wildlife studies will be used to determine hazard wildlife use of the mitigation area, and any conflicts with FAA requirements regarding wildlife attractants near airports. Monitoring activities may include seasonal bird counts to determine levels of use and presence/absence of specific avian species. If results of the monitoring activities suggest that hazard birds are using the mitigation site, corrective actions regarding planting schemes and/or hydrologic regimes may be implemented following procedures identified in the wildlife monitoring plan. Any measures to control hazard wildlife that are recommended as a result of this monitoring will be reported to the agencies in the regular post-construction monitoring reports to ACOE and Ecology.

Mitigation sites will also be monitored for non-hazard wildlife (e.g., amphibians) during annual monitoring visits. Wildlife will be evaluated by assessing wildlife habitat components (i.e., vegetation structure, diversity and cover, or habitat elements such as coarse woody debris), and to determine if performance standards are met. There are no performance standards that require monitoring of wildlife use or populations. However, during monitoring visits, observations of wildlife will be made and reported rather than directly sampling wildlife populations.

Channel Morphology and Instream Habitat

Channel morphology and instream habitat will be evaluated using standard methods in stream ecology (Hauer and Lamberti 1996). These methods will be used to measure variables such as channel profiles, cross sections, substrate size, type and amount of large woody debris, canopy cover from riparian vegetation, and type and number of habitat features (e.g., undercut banks, side channels, pools). Channel morphology and instream habitat features will be evaluated during regular monitoring visits, as well as following storm events. In addition, biological monitoring will be conducted in Miller Creek to evaluate changes in the Benthic Index of Biotic Integrity (BIBI) over the 10-year monitoring period (Karr and Chu 1999). Visual inspections and photo documentation will also be used to evaluate channel morphology, the stability of habitat features, and evidence of erosion or scouring.

Sample Data Sheets

Sample data sheets in Appendix H show the general format and type of information to be recorded during regular monitoring visits. These data sheets reflect typical measurements of hydrology, wildlife, photographic documentation, plant cover, and plant growth that will be measured during monitoring visits.

4.2.2 Adaptive Management Approach

Implementation of contingency actions and other management activities on the mitigation sites will be based on an adaptive management strategy using performance standards to trigger contingency and management actions. "Adaptive Management" recognizes that since the best contingency and management actions cannot always be predicted in advance and for all potential site deficiencies, they are determined on a case-by-case basis. Monitoring results will be used to identify any areas in which mitigation sites are not meeting performance standards, evaluate the reason(s) performance standards are not being met, and design and implement appropriate contingency actions.

If necessary, the first step following monitoring will be to determine why performance standards are not being met, and to identify key contributing factors (e.g., unusual drought, inadequate hydrology, invasive species, small mammal damage). Once contributing factors are identified, appropriate contingency measures to remove or ameliorate the contributing factors will be designed and implemented. Effects of contingency measures will be monitored to ensure that they have the desired result. The results of monitoring the efficacy of contingency measures will be used to fine-tune or adjust contingency measures to increase their effectiveness. Any planned contingency actions, as well as the results of implementing specific contingencies will be fully documented and reported in the regular post-construction monitoring reports. Additional information is provided in the following sections on the weed management strategy for all mitigation sites and the relationship of the WHMP (USDA 2000) to the mitigation sites in the Miller and Des Moines Creek basins.

4.2.2.1 Maintenance and Contingency

The mitigation projects are designed to be self-sustaining over the long term and are not anticipated to require significant routine maintenance following the 10-year monitoring period. However, during the monitoring period, some maintenance actions will be required on the mitigation sites.

Both routine maintenance tasks (e.g., maintaining irrigation systems) and adaptive management/contingency measures (e.g., weed management, replacing plants) will be required during the monitoring period to ensure that overall objectives and goals are met.

Routine Maintenance

Routine maintenance will include maintaining temporary irrigation systems, repairing or maintaining TESC measures, removing trash, repairing fences and signs, replacing dead plant material, maintaining herbivore deterrents (e.g., geese exclusion devices, herbivore collars), and methods for control of invasive plant species. For the first year following planting, the landscape contractor will be responsible for ensuring the health of planted material and for replacing dead or severely stressed plant material. After the first year, the Port will be responsible for maintaining plants and will replace plants as needed based on performance standards and consistent with specified contingency measures. Additionally, if any of the trees planted in mitigation projects within 10,000 ft of STIA runways create prime roosting habitat for starlings, blackbirds, crows, or raptors, the Port may remove these trees to conform with FAA mandates regarding aircraft safety and bird hazards. In this eventuality, the Port will replace these plants with small trees or shrubs, consistent with the WHMP.

Routine invasive plant species control includes actions such as maintaining areas of mulching or weed fabric around planted stock, application of herbicide and/or mowing areas in between planted stock. Routine weed control does not include contingency measures that are needed to meet the invasive species performance standard for re-vegetated areas of no more than 10 percent cover at monitoring year 10. Additional weed control methods are discussed below under contingencies.

The need for maintenance is anticipated to decline during the monitoring period, as the mitigation has been designed to be self-sustaining in the long term. Maintenance will continue as needed for as long as the compliance monitoring period (i.e., at least 10 years).

4.2.2.2 Contingency Measures

Specific contingency measures have been developed for each performance standard at each mitigation site. Contingency measures will be implemented following the adaptive management approach in cases where performance standards are not being met. Proposed contingency actions will be fully discussed in monitoring reports submitted to the agencies, and all contingency measures will be monitored and evaluated to verify that they are achieving the desired result. Project-specific contingency measures are included with the individual project descriptions in Chapter 5 and Chapter 7 of this document. The Port will consult with ACOE and Ecology prior to implementing any additional contingency measures that may be required, but that are not included in this document.

Control of invasive non-native plant species will likely require contingency measures on most of the mitigation sites during the first several years following construction. Specific control measures will depend on the invasive species of concern and site conditions. The Port will use an integrated, adaptive weed management strategy to control invasive non-native species on the mitigation sites. This strategy is explained in Section 4.2.2.4.

4.2.2.3 Wildlife Hazard Management

Monitoring and maintenance/contingency actions for the in-basin mitigation areas adjacent to STIA will be coordinated with the Port's WHMP. Regular reports on the results of monitoring for hazard wildlife at the mitigation sites will be included in the mitigation monitoring reports submitted to regulatory agencies.

The mitigation and implementation plans have been designed to be consistent with the FAA-approved WHMP, while providing for the restoration of wetland and stream functions potentially impacted by the project. Because the specific requirements of the WHMP (e.g., choice of plant species) were incorporated into the mitigation designs to avoid wildlife hazards at the mitigation sites, it is not anticipated that alterations to the mitigation sites will be necessary to comply with the requirements of the WHMP. The Port will monitor the mitigation sites regularly as part of its routine hazard wildlife monitoring program. Activities on the mitigation site for the purposes of wildlife hazard management would be consistent with permit conditions. The mitigation monitoring reports will identify hazard wildlife management activities (if any) on the mitigation sites.

In the event that the FAA determines that the mitigation measures have created a wildlife hazard to aircraft based on information obtained from the wildlife monitoring program, the wildlife hazard will be addressed according to the WHMP. The process will be as follows:

- The FAA will consult with the United States Department of Agriculture – Wildlife Science Division (WSD).
- The WSD will recommend a list of strategies that can be used to eliminate the problem.
- The Port and WSD will implement the strategies to eliminate the hazard.
- Implementation will be consistent with the wildlife hazard, and depending on the nature of the action, agencies will be properly notified.

4.2.2.4 Integrated Weed Management

An integrated weed management strategy will be used at all mitigation sites that will allow the successful establishment of native vegetation and prevent long-term dominance of the site by invasive and non-native plants.⁵ The goal of the weed management plan can be accomplished by a combination of the following steps:

- Reducing existing on-site sources of invasive non-natives by measures such as stripping the soil surface to remove above and below-ground plant parts, mowing and/or applying herbicide
- Planting rapidly growing native species that will quickly establish cover and shade on the mitigation site to reduce weed invasion in the short-term

⁵ The plan assumes that complete eradication of non-native plants, especially invasive non-native plants, is not possible because the mitigation sites are surrounded by large sources of non-native seeds. A variety of bird species are also expected to import native and non-native plant species to the sites. The presence of some non-native species will likely be a permanent feature of the mitigation sites.

- Using hydroseed/mulch to establish an initial “weed barrier” to provide initial plant cover on the site, and reduce colonization by invasive species
- Using sterile mulch around new plantings as a weed barrier
- Monitoring the site for new weed invasions and controlling or removing invasive species before they are allowed to dominate the site

Control of invasive plants will be most important during the initial years (i.e., 1 through 7) of the monitoring period while the native vegetation is becoming established. Control methods include, but are not limited to, using manual/mechanical methods to mow, cut, grub, or girdle plants, and selective use of EPA-approved herbicides. Use of herbicides will be minimized. However, limited herbicide use in combination with other control methods may be necessary to control some of the aggressive invasive species likely to occur on the site (e.g., Himalayan blackberry [*Rubus discolor*], reed canarygrass [*Phalaris arundinacea*]).

Miller Creek Rehabilitation/
Vocals Park Restoration

AR 048679

5. IN-BASIN MITIGATION PROJECTS

This chapter describes in-basin mitigation projects that are designed to restore and enhance physical and biological functions in Miller and Des Moines Creeks and nearby wetlands. The Port will provide on-site (i.e., in-basin) mitigation in both the Miller Creek and Des Moines Creek basins to compensate for unavoidable project impacts to wetland, stream, and hydrologic functions. In developing this plan, the Port utilized agency guidance to identify in-basin mitigation activities that will compensate for project impacts to wetland and stream functions. Elements of the mitigation plan are specifically targeted at restoring in-basin functions that will be impacted by the project, such as sediment and nutrient retention (water quality), organic carbon production and export, surface water storage (flood water detention and storage), and aquatic habitat functions (e.g., instream aquatic habitat and riparian habitat).

The mitigation plan will result in increased functional performance of the wetlands, streams, and stream buffers in the mitigation sites relative to their degraded existing conditions. For example, wetlands currently dominated by non-native ornamental vegetation and turf grasses will be restored to forested systems containing a greater diversity of native species and habitats. Along Miller and Des Moines Creeks, water storage, nutrient and sediment retention, instream habitat, and non-avian wildlife habitat functions will all be improved relative to existing conditions.

The in-basin mitigation projects described below include the following projects.

Miller Creek Basin

Vacca Farm Mitigation: Miller Creek Relocation (Section 5.1.1), Vacca Farm Wetlands and Floodplain Restoration (Section 5.1.2), and Lora Lake Buffer Shoreline Enhancement (Section 5.1.3)

Miller Creek Wetland and Riparian Buffer Enhancement (Section 5.2.1)

Miller Creek Instream Habitat Enhancements (Section 5.2.2)

Drainage Channel Replacement (Section 5.2.3)

Restoration of Temporary Construction Impacts (Section 5.2.4)

Des Moines Creek Basin

Tyee Valley Golf Course Wetland Enhancement (Section 5.3.1)

Des Moines Creek Buffer Enhancement (Section 5.3.2)

The sections in this chapter provide descriptions and plans for each of the in-basin mitigation projects. Section 5.1 describes relocation and restoration of a portion of the Miller Creek channel; restoration and enhancement of the Lora Lake shoreline; and restoration of wetlands, floodplain, and buffers on the Vacca Farm site. Section 5.2 describes mitigation projects to restore and enhance wetlands and riparian buffers along a 6,500-ft reach of Miller Creek, and to enhance instream

habitat along this reach. In addition, mitigation actions to restore wetlands temporarily impacted by construction the design and replacement drainage channels (Section 5.2) that mitigate for filling of existing ditches and drainage channels are described.

The describes restoration projects in the Des Moines Creek (Section 5.3) basin are designed to enhance existing wetlands on the Tyee Valley Golf Course and to enhance the riparian buffer along sections of Des Moines Creek. Plans to minimize and mitigate potential indirect hydrology impacts to wetlands near the borrow areas are also provided.

For each mitigation project described in this chapter, the mitigation plans are organized following Ecology guidance (Ecology 1994). The mitigation plan, goals, and objectives are introduced first, followed by a description of the project site, existing ecological conditions, the rationale for selecting the project, and any constraints on the proposed mitigation. Next the mitigation design is described in detail, with reference to figures and the plan sheets in Appendices A through E. Performance standards, monitoring schedules, and maintenance and contingency measures necessary to ensure mitigation success, are described next. The final section for each project describes the specific construction steps, methods, and sequencing required to implement the mitigation design.

5.1 VACCA FARM MITIGATION

Mitigation actions at the Vacca Farm site are designed to enhance approximately 17 acres of aquatic and riparian habitats by restoring natural channel morphology to Miller Creek, integrating the channel with its floodplain, removing bulkheads along the Lora Lake shoreline, and restoring functions to wetlands, farmed wetlands, prior converted croplands, and riparian and upland buffers on the site (Table 5.1-1; Appendix A). These actions will enhance fish habitat in Miller Creek, improve water quality (provide shade, ameliorate elevated water temperatures, increase dissolved oxygen, provide inputs of organic matter, improve sediment retention, and remove potential sources of fertilizer or pesticide inputs), provide no net loss of floodplain storage, and enhance the diversity and complexity of wetland habitats. Mitigation projects in the Vacca Farm area have also been designed to reduce the potential wildlife hazards that currently exist on the site, consistent with FAA Advisory Circular 150/5200-33. The major mitigation elements for the Vacca Farm site include the following:

- Relocation of a channelized portion of Miller Creek
- Restoration of natural channel morphology and instream habitat to the relocated reach
- Restoration and enhancement of riparian buffers along Miller Creek
- Restoration and enhancement of floodplain wetlands on the Vacca Farm site
- Restoration and enhancement of upland buffers around the Vacca Farm site
- Restoration and enhancement of wetland and upland buffers along the Lora Lake shoreline
- Removal of bulkheads from the Lora Lake shoreline, and restoration of a more natural shoreline along the lake

Table 5.1-1. Summary of wetland mitigation areas at Vacca Farm.

Mitigation Area at Vacca Farm	Wetland Area (acres)
Wetland Restoration	6.60
Wetland Enhancement	
Wetlands (A1, A1a, A2, A3, A4)	1.59
Farmed Wetlands (1, 2, 3, 9, 10, 11)	0.73
Lora Lake shoreline	0.32
Lora Lake aquatic habitat	3.06
Subtotal	5.70
Buffer Enhancement	
Des Moines Memorial Drive Buffer	1.54
Stream Buffer	3.04
Lora Lake Buffer	0.27
Subtotal	4.85
Total Restoration Area	17.15

5.1.1 Miller Creek Relocation and Channel Restoration Plan

To accommodate the embankment for the third runway, the RSAs, and the relocation of South 154th Street, approximately 980 ft of Miller Creek will be realigned and relocated. The new stream channel will be constructed approximately 200 ft west of the existing channel, through the Vacca Farm site. The channel reach to be relocated has been dredged and straightened, lacks complexity (e.g., straight uniform channel bed, no undercut banks, no side channels, no pool/riffle morphology, uniform silty substrate), there are few instream habitat features (e.g., no large woody debris, no pools or backwater areas), and the riparian vegetation provides little shade or organic matter to the channel.

Relocating the stream will increase the channel length to approximately 1,080 ft. A low-flow channel will meander within a larger high-flow channel, and the new channel will include instream habitat features (e.g., large woody debris). The channel will be designed to be connected to the floodplain by overbank flooding with approximately a 1-year return interval. Channel banks will be planted with native shrub plant communities and the new channel will have a native forested riparian zone to ameliorate water quality, and provide shade and large woody debris.

5.1.1.1 Goals, Objectives, and Design Criteria

The overall goals of this plan are to provide a new, longer stream channel with enhanced habitat features and a more natural channel morphology compared to the existing channel that will be filled. The channel design is constrained by the existing high and low flow conditions in Miller Creek and the very gradual slope of the channel through this reach. The goals of the design are focused on the need for the relocated channel to continue to convey base flows, to maintain sufficient depths during summer low-flow periods for fish passage, to prevent deposition of fines and scouring to maintain

fish habitat, and to allow flood flows greater than annual peak flows to overtop the channel banks and flow onto the floodplain. Specific goals for the design of the relocated channel are:

- The stream continues to provide base flow conveyance.
- Minimum flow velocity remains high enough to minimize fine sediment deposition.
- The new channel accommodates peak flows up to the 100-year flow with no net reduction of 100-year floodplain storage or floodway conveyance.
- The new channel provides improved fish habitat.
- The new channel replaces or enhances riparian habitat function.
- The channel does not attract wildlife (such as waterfowl or flocking birds).

The goals are prioritized from the most critical hydrologic functions that the existing channel provides to enhancements that will improve channel and riparian habitat.

To implement the general goals identified above, specific objectives and design criteria were developed (Table 5.1-2). Specific performance standards, monitoring approach, and contingency measures for the channel relocation are discussed in more detail in Section 5.1.1.10.

Table 5.1-2. Mitigation goals, design objectives, and design criteria for the Miller Creek relocation project.

Goals and Design Objectives	Design Criteria
Goal 1: The stream will continue to provide base flow conveyance	
Provide flow depths to allow fish passage, prevent fish stranding, and provide habitat.	Construct low flow channel 8 feet wide with 1:1 slopes and 0.5 ft deep to convey summer base flows. Construct high flow channel 32 feet, side slopes of 2:1 (typical) from depths of 0.5 to 1.0 ft to provide capacity for wet season base flow.
Goal 2: Low flow velocity should minimize fine sediment deposition	
Minimize sedimentation with minimum flow velocity.	The channel cross section will provide an average dry season base flow velocity that is greater than the silt transport velocity (0.7 ft/sec). Design a natural channel with stable gravel bottom.
Minimize channel scouring at the maximum design flow velocity.	Channel flow velocity cannot exceed the gravel movement velocity (4 ft/sec) for the 100-year flow.
Goal 3: The channel will accommodate peak flows, including the 100-year flow	
Accommodate the 100-yr-peak flow.	Flows greater than the annual peak flow will overtop the channel and inundate the adjacent floodplain restoration.
Goal 4: The new channel will provide enhanced fish habitat	
Provide enhanced fish habitat without fish passage barriers.	Provide a natural channel configuration. Increase channel length by about 10 percent and a meandering low flow channel. Provide habitat features, including instream features such as deflectors and overhanging logs as needed to maximize available habitat.

Table 5.1-2. Mitigation goals, design objectives, and design criteria for the Miller Creek relocation project (continued).

Goals and Design Objectives	Design Criteria
Goal 5: The channel will replace and enhance riparian habitat function	
Provide riparian habitat.	Provide a minimum 50ft vegetated buffer on the east side of the channel. Establish native vegetation along channel banks and the riparian zone of the new channel.
Goal 6: The channel will not attract wildlife	
	Densely plant woody vegetation along the new channel to cover open water and reduce use of the area by waterfowl.

5.1.1.2 Ecological Assessment of Miller Creek at Vacca Farm

Overall conditions in the Miller Creek basin are described in Chapter 2. In this section, existing conditions at the Vacca Farm site relevant to the mitigation design are described in more detail. Miller Creek originates north of SR 518, flows south through the Miller Creek detention facility along the southeast side of Lora Lake, and then south along the eastern edge of the Vacca Farm site. The Miller Creek detention facility detains and stores flood waters from the upper reaches of the Miller Creek basin during periods of high flow. Vacca Farm sits in a broad, flat valley of alluvial sands, silts, and peat soils located south of Lora Lake. Through the Vacca Farm site, portions of Miller Creek have been channelized and straightened to improve drainage on the site. From the Vacca Farm site, Miller Creek continues south and west through residential areas and ultimately empties into Puget Sound (see Figure 2.1-2 and 2.2-1).

The Miller Creek channel between the Miller Creek detention facility outlet to South 156th Way has been dredged and straightened to drain wetlands for farmland reclamation. Topographic conditions, peat soils, and seasonally high water tables along this reach indicate that this area was historically a wetland. The channel currently overflows its banks with at least a 2-year frequency with full flow velocity of 1.7 ft per second (see Figure 2.2-2)(FAA 1996). Frequent flooding is primarily the result of limited channel capacity, in part due to channel slope.

Miller Creek is approximately 4 to 10 ft wide and 2 ft deep below the outfall of the Miller Creek detention facility. The bank is lined with large rocks in the upper segments near Lora Lake, and the channel has a very silty substrate. The section of the stream within the Vacca Farm site that will be relocated is a ditched reach with a silty bottom substrate. Downstream of South 156th Street, the channel contains natural meanders that vary from approximately 5 to 10 ft in width and the substrate consists of areas of sand and gravel with some silt.

A side channel (ditch) in the Vacca Farm site runs parallel to and west of the main channel. The side channel does not drain runoff from a distinct subbasin area nor does it provide additional channel capacity to the main channel. Rather, it provides positive drainage for a portion of the relatively flat farmland located west of Miller Creek.

Hydrology

Urbanization and development of the watershed have led to increased runoff rates and volumes that have contributed to erosion and downcutting. Increased erosion and downcutting have also resulted in sedimentation and habitat degradation in the low-gradient areas (FAA 1996). In 1990, King County constructed the Miller Creek detention facility to alleviate some of these impacts (see Figure 1.3-1).

Since 1982, King County Surface Water Management (KCSWM) has monitored flow rates at the outlet of the Miller Creek detention facility (KCSWM 1994). The available flow data provide a good record of base flows, normal wet and dry season flows, and annual peak flows. Stream flow rates are typically highest between October and April and lowest between May and September (FAA 1996). Montgomery Water Group (1995) modeled hydrologic characteristics in the basin and found that in some years no flow occurs in the upper watershed areas during portions of the summer (i.e., 1-in-10 year low flow). They also reported that summer flows are 0.5 cubic feet per second (cfs) less than about 10 percent of the time. Flows during the dry season and wet season are shown in Table 5.1-3. Table 5.1-4 summarizes data for flood frequency estimates in Miller Creek at the Miller Creek detention facility.

Table 5.1-3. Estimated base flow rates at the Miller Creek detention facility outlet structure.

Season	Flow Rate (cfs)
Dry (May – September)	0.5
Wet (October – April)	5.0
Approximate Annual Peak	40.0

Source: KCSWM (1994)

Table 5.1-4. Flood frequency estimates for Miller Creek at the Miller Creek detention facility control structure.

Return Period (years)	Peak Flow Rate (cfs)
1.01	21
1.11	40
2	75
10	125
20	141
50	161
100	175

Source: Montgomery Water Group (1995)

Existing Fish Habitat

Historically, Miller Creek supported anadromous fish runs of coho salmon (*Oncorhynchus kisutch*), chum salmon (*O. keta*), and sea-run cutthroat trout (*O. clarki clarki*), as well as resident populations of pumpkinseed sunfish (*Lepomis gibbosus*), sculpin, and cutthroat trout (FAA 1996). A qualitative

electrofishing survey conducted in August 1996 identified cutthroat trout, pumpkinseed sunfish, and three-spine stickleback (*Gasterosteus aculeatus*) in reaches between South 160th Street and the outlet of Lake Reba (Aquatic Resource Consultants 1996). One coho smolt was captured downstream of the culvert under South 160th Street during a 1996 electrofishing survey. In addition, three cutthroat trout were found north of a natural waterfall above South 160th Street during another electroshocking study on November 10, 1998 by Parametrix, Inc.

The stream currently supports a small coho salmon run maintained by annual releases of hatchery-reared fingerlings raised by the Des Moines Chapter of Trout Unlimited (FAA 1996; Hillman et al. 1999). No spawning activity was observed during surveys conducted in 1996 by WDFW. However, the Des Moines Chapter of Trout Unlimited reported 91 coho spawners in a recent survey. The Port has prepared a Biological Assessment which evaluates the affect of the MPU improvement projects on fish species recently listed under the Endangered Species Act (ESA) (Parametrix 2000d).

Residential development in the watershed has resulted in a general deterioration of fish habitat due to removal of native riparian vegetation, stream channelization and bank armoring, filling of riparian wetlands, reduction of the availability of large woody debris, and increased runoff rates and non-point source pollution loading. The expansion of impervious surface area in the basin has caused increased volumes and velocities of stormwater runoff resulting in increased bank erosion, and downcutting. These factors have contributed to a general lack of (1) instream cover, (2) available low- and high-flow habitat or refuge, (3) available spawning habitat in the basin, (4) habitat complexity, and (5) high-quality water (KCSWM 1987; and FAA 1996).

Natural, unaltered stream reaches in the Miller Creek basin are essentially nonexistent, while major portions of the main stem and associated drainage ditches are channelized or otherwise modified (KCSWM 1987). The portion of the stream crossing the Vacca Farm site, which has been channelized, lacks woody debris, and provides limited habitat complexity. This reach is dominated by low-velocity flows, and excessive sedimentation, which appears to be partially caused by agricultural runoff. FAA (1996) estimated that 10 tons of sediment are transported to the stream annually from approximately 11 acres of adjacent agricultural land. These factors contribute to the lack of pools, and therefore a lack of refugia for fish during high-flow events.

Several natural and man-made barriers appear to limit fish access to the upper basin; however, they are not barriers under all flow conditions. The most prominent barrier on Miller Creek is a natural 8-ft-high waterfall about 0.2 mile upstream of South 160th Street that restricts upstream fish passage. Several corrugated metal and concrete box culverts, such as a culvert located at South 160th Street, appear to be barriers under certain flow conditions.

These barriers, combined with habitat availability, likely contribute to the current fish distributions in Miller Creek; salmonids occupy primarily downstream reaches while other species occur upstream. Recent studies (FAA 1996; Hillman et al. 1999) have found that suitable coho salmon spawning habitat and evidence of coho salmon spawning is limited to the area downstream of First Avenue South, while suitable cutthroat trout spawning habitat was scattered in small patches between South 156th Way and First Avenue South. Areas upstream of First Avenue South consisted predominantly of a fine silt and sand substrate, which is more suitable habitat for the non-salmonid fish species that occur there.

Existing Riparian Vegetation

Downstream of the Miller Creek detention facility, about 200 linear ft of the stream are bordered by small tree and shrub riparian vegetation. Riparian vegetation consists of stands of red alder saplings (*Alnus rubra*) with an understory of hardhack (*Spiraea douglasii*), Himalayan blackberry (*Rubus discolor*), and field horsetail (*Equisetum arvense*).

Throughout most of the Vacca Farm site, riparian vegetation associated with Miller Creek is typically a narrow band less than 50 ft wide. Riparian vegetation is dominated by reed canarygrass (*Phalaris arundinacea*), climbing nightshade (*Solanum dulcamara*), and introduced grass species. Scattered throughout this area are black cottonwood (*Populus trichocarpa*), and willow (*Salix* spp.) trees and saplings. This narrow band of low-quality riparian vegetation separates the stream from the adjacent cultivated farmland.

5.1.1.3 Ownership

Property at the Vacca Farm site and along Lora Lake needed for the stream relocation has been purchased by the Port as part of the larger property acquisition program for the proposed Master Plan Update improvements.

5.1.1.4 Rationale for Selection

The Miller Creek relocation mitigation provides the opportunity to restore both high quality stream habitat and floodplain wetland habitat that will result in on-site, in-kind replacement for stream and wetland functions impacted by the MPU projects. The existing portion of Miller Creek that will be relocated was moved from its original location within the floodplain at the Vacca Farm site to increase the amount of floodplain suitable for farming. The original channel was moved to the east, straightened, and dredged to facilitate drainage and increase agricultural land on the site. As a result, although the channel still floods, it lacks the connection with its floodplain and floodplain wetlands that it historically had. The channel does not meander across the floodplain and there are no side channels, sloughs, or backwater areas. The existing channel lacks complexity (e.g., straight uniform channel bed, no undercut banks, no side channels, no pool/riffle morphology, uniform silty substrate), there are few instream habitat features (e.g., no large woody debris, no pools or backwater areas), and the riparian vegetation provides little shade or organic matter to the channel.

Relocation and restoration of channel morphology therefore provides the opportunity to restore both aquatic habitat and floodplain wetland functions on the site. The mitigation plan for the channel relocation will restore channel morphology and instream habitat. In addition, the connection between channel and floodplain wetlands will be restored to the extent possible, while avoiding the creation of new hazard wildlife attractants near the airport. Integration of channel and floodplain will be designed to allow the channel to flood periodically, but to avoid standing water in floodplain wetlands.

5.1.1.5 Constraints

Relocation of Miller Creek must occur on-site in proximity to the existing channel. The Vacca Farm site is nearly level, with only a few feet of grade change from north to south. The alignment for the new channel has been designed to facilitate meeting design criteria for flow and velocity given the existing site topography. Meeting these criteria requires that the stream relocation reach be as short as possible to ensure that the maximum channel slope is maintained. The length of the relocated stream reach cannot be increased and still meet the minimum gradient for required flow velocities and depth. As a consequence of constraints on channel length, the new channel will remain fairly close to the re-aligned roadway and the embankment. The buffer width between the relocated stream and South 154th Street is constrained by the maximum length of the new stream channel (Figure 5.1-1). Constraints on the channel design are described in detail in Section 5.1.1.6, Channel Relocation Mitigation Design.

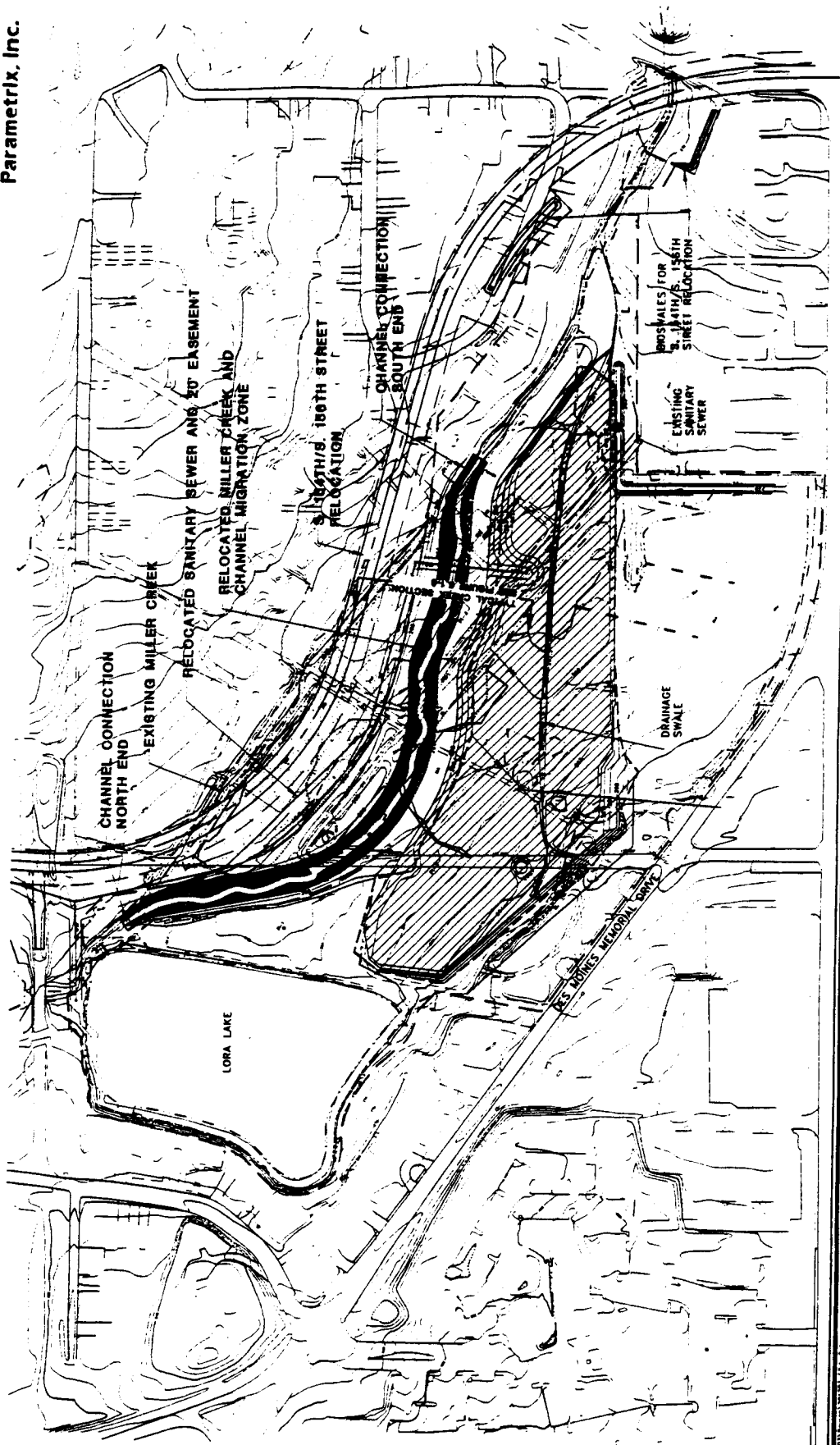
No other apparent constraints outside of the Port's control could affect the success of the stream relocation. No plans exist to change the Miller Creek detention facility's operation procedure. Stormwater management is now planned to occur in new facilities (i.e., vaults and/or ponds located in upland areas) that are independent of the Miller Creek detention facility (for details, refer to the *Stormwater Management Plan*, Parametrix 2000a). However, even if the existing detention facility were enlarged to provide more flood storage, this would not be expected to change flow rates in Miller Creek. The detention facility could be enlarged to provide greater stormwater storage without increasing the maximum elevation of water storage or peak discharge rates. This could be accomplished by excavating uplands that are located south of the facility to an elevation within the operating range of the facility to provide new storage. This will not affect the mitigation design because stream hydrology, specifically base flow and normal seasonal flow, will not be significantly modified, and it is unlikely that peak stormflows will be increased.

5.1.1.6 Channel Relocation Mitigation Design

The goals of the design are focused on the need for the relocated channel to continue to convey base flows, to maintain sufficient depths during summer low-flow periods for fish passage, to prevent deposition of fines and scouring to maintain fish habitat, and to allow flood flows greater than annual peak flows to overtop the channel banks and flow onto the floodplain.

Channel Design

The channel design process evaluated and adjusted design variables and constraints (e.g., channel depth, width, flow velocity, channel slope, etc.) to meet the design goals and criteria. The critical variables in new channel design are channel slope, flow velocities (i.e., dry and wet season base flows, annual peak flows, and flood flows above annual peak flows), maximum design flow, channel depth and bottom width, channel roughness, and channel length. Initial channel slope was determined using the available drop in elevation along the new reach. The corresponding channel bottom width was determined and adjusted until the minimum flow depth (0.25 ft) was achieved. The slope was then adjusted until the base flow velocity was high enough to move sediment particles smaller than sand to reduce siltation and fining of the bed. Using the adjusted slope, the channel was then designed to convey peak flows (in connection with maximum depths and channel configurations described in the following sections). Channel widths and flow depth were then adjusted to assure that peak flow velocities were less than the transport velocity for gravel.



FILE: \\s:\projects\103103\103103.dwg
DATE: 12/11/200

0 80 160'
SCALE IN FEET

LEGEND
 RELOCATED SANITARY SEWER
 EXISTING SANITARY SEWER
 WETLAND BOUNDARY
 EXISTING CONTOUR
 PROPOSED CONTOUR
 LIMIT OF CONSTRUCTION
 FILLED FLOORPLAN
 8,455 CY (574 AC.-FT.)
 WETLAND (VERMONT)
 PROPOSED FLOORPLAN EXCAVATION
 9,589 CY (594 AC.-FT.)

Figure 5.1-1
Vacca Farm Wetland Restoration
Grading Plan

Hydrology

The hydrologic design criteria for the Miller Creek relocated channel design are listed in Table 5.1-2. Design criteria for determining base flow, annual peak flow, and 100 year flow conditions were established from data gathered by KCSWM. These flow rates were determined from data gathered at the outlet of the Miller Creek detention facility (which includes Lake Reba), which is several hundred feet upstream of the mitigation site. Data have been gathered at this location since 1988 (KCSWM 1994). These flow data provide a good record of normal base flows, seasonal peak flows, average flows by season, and extreme flows during near-record events. Design criteria for base flow and annual peak flow conditions were established from these data (Table 5.1-5). Statistical analysis of the flow monitoring data was not conducted.

Table 5.1-5. Estimated flow rates for Miller Creek channel design.

Flow Regime	Flow Rate (cfs)
Dry season base flow	0.5
Wet season base flow	5
Stormflow	10
Annual peak flow	40
2-year peak flow	75
10-year peak flow	125
100-year peak flow	175

Source: Montgomery Water Group (1995); with additional data compiled by Parametrix.

In addition to monitored flow rate data, a detailed hydrologic modeling study was prepared (Montgomery Water Group 1995) that calculated peak flow rates for flood frequencies up to the 100-year flood (Table 5.1-6). The flood return frequencies were calculated assuming that the Miller Creek detention facility detention system and control structure is in place. The calculated flow rates appear to be consistent with the flow monitoring data. The peak monitored flow rate (225 cfs) on November 24, 1990 was in excess of the current predicted 100-year flood flow. The control structure was constructed after the 1990 storm; it is likely that the peak flow rate of November 1990 would have been reduced by the detention system. Because stormwater runoff would be mitigated in separate stormwater management facilities, this plan does not increase channel capacity for increased flows.

Table 5.1-6. Flood frequency estimates for Miller Creek at the Miller Creek detention facility control structure.

Return Period (years)	Peak Flow Rate (cfs)
1.01	21
1.11	40
2	75
10	125
20	141
50	161
100	175

Source: Montgomery Water Group (1995).

Stream Hydraulics

Stream hydraulics are the existing or proposed physical conditions that influence the direction, depth, and flow velocity in the proposed relocated stream. Several factors influence hydraulics, including flow rates, channel slope, channel cross section, channel roughness, and flow depth. While several of these features will be designed, factors such as flow rate or average channel slope cannot be modified. The following sections discuss the design parameters that apply to all channel segments, and the proposed channel configuration for each segment.

Flow Velocity

Channel flow velocity is the primary variable influencing channel design and fish habitat. The low flow goal is to minimize fine-grained (sands and finer) material sedimentation in the proposed channel during normal dry season base flows. Conversely, the flow velocity at peak flows must not exceed rates that would erode the channel banks or scour loose substrate larger than small gravel.

The relationship between flow velocity and sediment transport velocity is shown in Figure 5.1-2. If the flow velocity equals or exceeds that shown for each grain size, the sediment can be expected to move until the velocity decreases. If the maximum velocity of a specific section of a stream channel is known, an estimate of the size of the bed material that would be relatively stable can be determined. These relationships are used to determine the size of stream substrate materials and their long-term stability. The Miller Creek channel design thus balances a minimum base flow velocity designed to prevent sedimentation, with a maximum peak flow velocity designed to prevent scouring. Using Figure 5.1-2, the channel parameters were adjusted to maintain base flow velocity greater than the silt movement velocity, but less than the gravel movement velocity for peak flow. Preventing gravel movement in the new reach will prevent scouring of the substrate.

Channel Slope

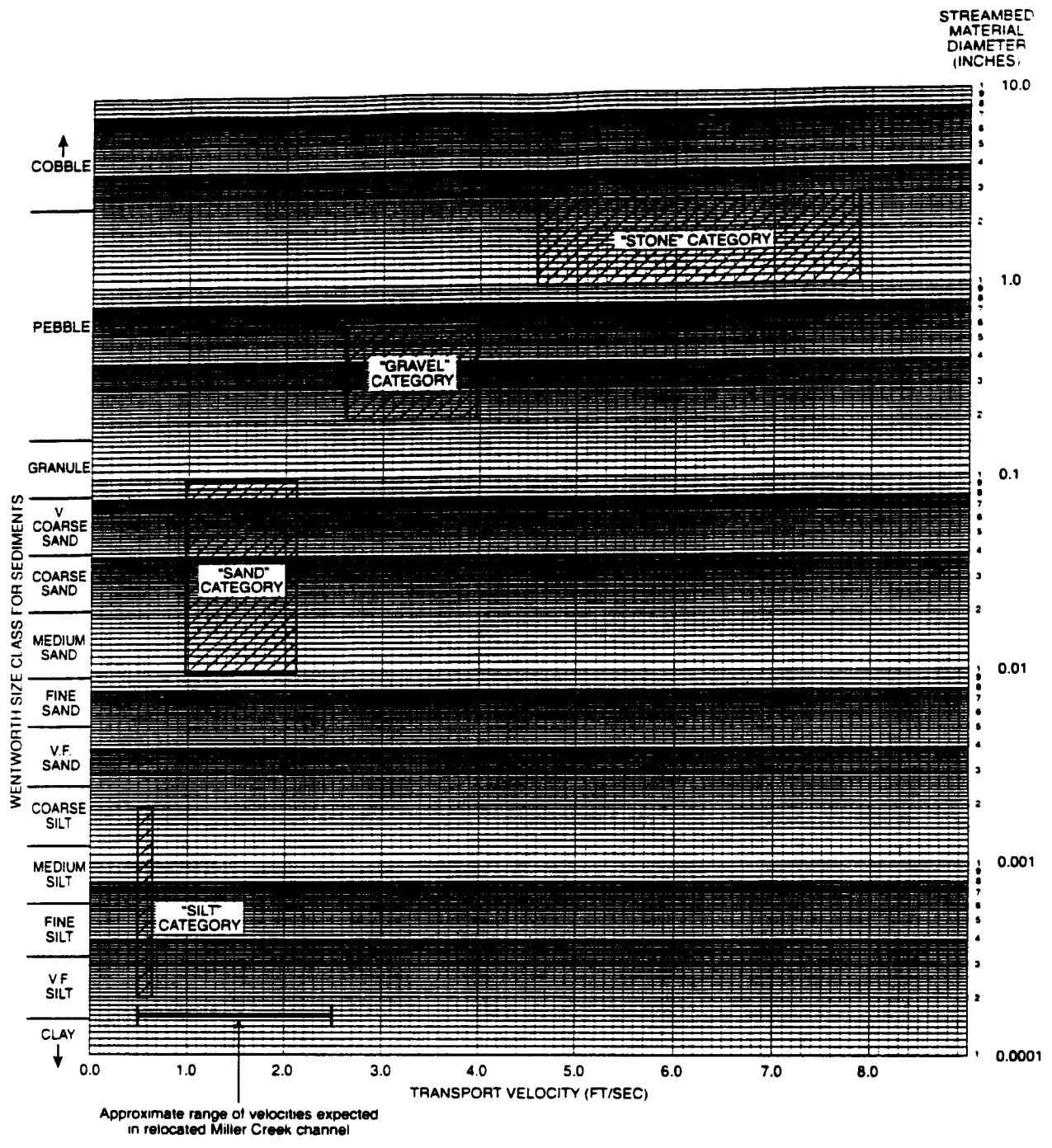
The average channel slope in the relocated reach is determined by physical constraints (i.e., topography) of the Vacca Farm site. The proposed channel drops 2.5 ft in approximately 1,118 ft for an average channel slope of 0.22 percent. The approximate elevation at the point where the relocated stream rejoins the existing channel is 260.0 ft. However, the natural land slope along the proposed stream channel does not drop continuously. Due to the small vertical drop over the relocated segment, a relatively uniform grade is proposed for Miller Creek.

Channel Flow Depth

Given the goals for fish habitat, desired substrate characteristics, and stream hydrology, flow depth standards have been determined. These flow standards are: (1) a dry season water depth of at least 0.25 ft; (2) a wet season water depth of 1 ft; (3) a maximum depth of 2 ft at the mean annual flow rate, and (4) flows greater than the annual maximum flow rate (40 cfs) will overflow the streambanks, flooding the Vacca Farm site.

Maximum Design Channel Flow

The topography and available channel slope in the project area limit constructing a large channel that can convey the 100-year storm while maintaining a minimum flow depth for dry season base flows. Therefore, the channel will overflow onto the floodplain at flows greater than approximately 40 cfs. The floodplain and floodway are designed to convey the 100-year flows of 175 cfs.



Source: Fisheries and Oceans (1980)

Pon of Seattle/Natural Resource Mitigation Plan/556-2912-001/01(03) 12/00 (K)

**Figure 5.1-2
Sediment Transport Velocity
vs. Sediment Diameter**

Channel Bottom Width

The channel bottom width for the relocated channel is largely controlled by the minimum low-flow depth of 0.25 ft. During the dry season, the water depth must average at least 0.25 ft to provide minimum depth for fish movement. To determine the channel bottom width, the base flow rate, slope, roughness, and side slopes were fixed, and the bottom width was adjusted until the flow depth was at least 0.25 ft. The results were checked to ensure that no other design criteria were changed to exceed design parameters. Results indicate that a channel bottom width ranging from 4 to 10 ft meets the design criteria for minimum flow depth. Thus, a low-flow channel between 4 and 10 ft wide will maintain a minimum flow depth of 0.25 ft during summer low flows to allow fish passage while conveying wet season base flows (Figure 5.1-3).

Channel Roughness and Side Slopes

Channel roughness, described by using Manning's roughness factor (n), is a key factor in determining channel capacity. The Manning's channel roughness factor for a natural stream channel with a gravel or stony bottom and limited instream vegetation is 0.0035. This factor was used for calculating channel capacity for the relocated reach. The Miller Creek relocated channel will consist of a high-flow or bench area and a low-flow channel. The low-flow channel will have an 18- to 24-inch-deep gravel streambed, and will be generally 4 to 10 ft wide by 6 inches deep. It will meander within the 32-ft-wide high-flow channel, forming a channel migration zone (see Figure 5.1-3). The low-flow channel is designed to convey base flows and to overtop its banks approximately once a year during annual peak flows (i.e., between approximately 20 and 40 cfs). The annual peak flows will be accommodated within the 32-ft high-flow channel. Flood flows greater than the annual peak flows (i.e., greater than 40 cfs) will overflow the streambanks onto the floodplain.

The new channel is located in an area with peat soils; however, the channel will not be constructed directly in peat soils without bank stabilization (see Figure 5.1-3). The streambanks will be constructed using blended soils and gravels wrapped in an erosion control fabric. The toe of the channel banks will be protected by installation of prefabricated logs made of dense coconut fibers wrapped in erosion control fabric. This construction method provides immediate erosion protection while also providing a rooting substrate that will facilitate revegetation of the banks. The area adjacent to the channel banks will be sloped toward the channel at 2 to 10 percent grade for positive drainage.

The side slopes of the low flow channel will be 1:1, which is required to maintain minimum flow depths of 0.25 ft for fish passage. This design will also allow some minor undercutting of channel banks over time to increase shelter for fish. Low flow channels of natural streams in the Puget Sound region typically have vertical side slopes (Rosgen 1994; Montgomery and Buffington 1993), and the design thus mimics natural stream channels. The side slopes of the new channel will be stabilized with bioengineering and the planting of native vegetation (i.e., primarily willow stakes). The low channel gradient and design of the low-flow channel to overflow into the larger channel during storms greatly decrease the likelihood of erosive flows.

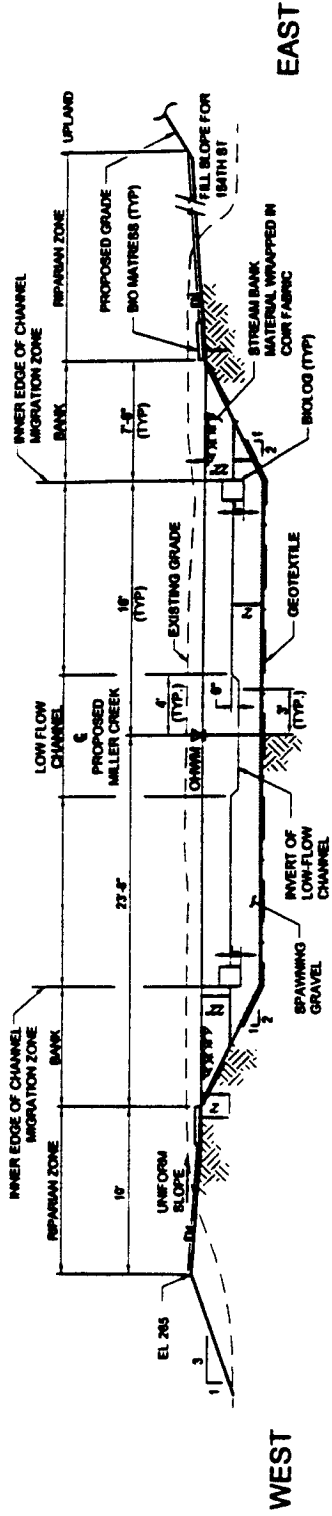


Figure 6.1-3
Channel Cross Section
Miller Creek Location

FILE: 201203_2531-1.dwg
DATE: 12/17/00
SCALE: HORIZONTAL 1"=10'
VERTICAL 1"=10'

Channel Alignment

The channel will be constructed to meander within the limits of the stream corridor as shown in plan and cross section in Figures 5.1-1 and 5.1-3. The extent of meandering is limited by the need to maintain a minimum channel slope to meet flow velocity goals.

Sewer Line Relocation

Relocation of Miller Creek (design and construction) will be coordinated with the realignment of the sewer line required by the relocation of South 154th Street. The sewer line will parallel the new road alignment (outside of the mitigation site boundary) and will cross under the new channel (see Figure 5.1-1). The sewer line will be approximately 4 ft below the invert of the new channel. The trench in which the sewer line lies will be backfilled with compacted fill material that will provide a stable surface over the sewer line. The Port has analyzed the need for additional stabilization below the new channel to protect the sewer line and the channel. This analysis indicates that because of the depth of the sewer line, the flat topography of the site, and the small size of the channel, no extra measures will be required to stabilize the channel over the sewer line. The new channel will be located in a portion of the Miller Creek floodplain that is more or less flat; stream velocities are low in this portion of the stream, and there is no potential for significant downcutting within the new channel reach. During periods of high flows, the channel is designed to overtop its banks and flow onto the floodplain, which further reduces any potential for downcutting.

The 20-ft easement for the relocated sewer will be located outside of the mitigation site boundaries, except where the line crosses under the stream. A maintenance access road will be located within the easement along the east side of the mitigation site; however, the access road will not go through the mitigation site (Appendix A, Sheet C2).

Wildlife Considerations

Design and implementation of mitigation for STIA must meet flight safety issues and FAA requirements. Collisions between birds and aircraft are a serious safety issue. Open-water areas, wetlands, and tall trees can create an aviation hazard by attracting waterfowl, small flocking birds (such as European starlings), and raptors. Fish can also attract birds, such as raptors or herons, that pose hazards to aviation. When these habitat features are within 10,000 ft of airport runways, the potential for collisions with aircraft can be serious. For these reasons, mitigation projects within 10,000 ft of STIA runways are designed, where feasible, to reduce existing wildlife hazards and avoid creating new hazards.

Fish habitat design standards for Miller Creek were developed based on the habitat requirements of cutthroat trout.⁶ The planned features include:

- Shading to minimize temperature increases during the summer
- Higher velocity riffles to maintain oxygen levels and reduce sedimentation

⁶ While coho salmon may find suitable rearing habitat in this area, flow conditions are not anticipated to be suitable for spawning coho.

- Placement of logs, rocks, or other structures to provide refuge
- Shading of the channel with native vegetation

Channel shading will enhance the stream habitat and also decrease the stream's visibility to birds of prey (e.g., herons, raptors) that would use the stream to collect food. Riparian vegetation will thus help reduce potential wildlife hazards along the channel. The following sections describe how the stream design will meet cutthroat trout habitat criteria and FAA requirements for aviation safety.

Instream Habitat

The instream habitat criteria used in the relocated channel design are based on general habitat requirements of the resident salmonid cutthroat trout and coho salmon, which could potentially use the site. Although anadromous salmonids have not been observed in the proposed impact areas, resident cutthroat trout are present. These criteria are used to provide the highest quality fish habitat possible. Designing the relocated stream to meet habitat requirements of salmonids helps ensure that the best possible fish habitat is created.

In general, salmonids require cool, well-oxygenated water; spawning gravel that is free of accumulated silt; and abundant instream cover for habitat. In addition, because habitat requirements vary as life stages change, habitat complexity within the stream is also necessary. General physical habitat requirements include access to critical habitat features, stable flows, appropriate stream substrate, and riparian and instream cover.

Salmonids require cover provided by such features as undercut banks, logs, boulders, deep pools, and overhanging riparian vegetation for feeding, hiding, and resting. In addition, these features help stabilize streambanks and substrate during high-flow periods. The relocated channel, which is designed with vertical banks in the low-flow depth range, will encourage minor undercutting to provide cover during low-flow periods. Large woody debris (e.g., deflector logs, angle logs, and root wads), and boulders will be used to stabilize the substrate, protect the upper banks from excessive erosion, and provide hiding and holding habitat for fish during higher flow periods (Figure 5.1-4).

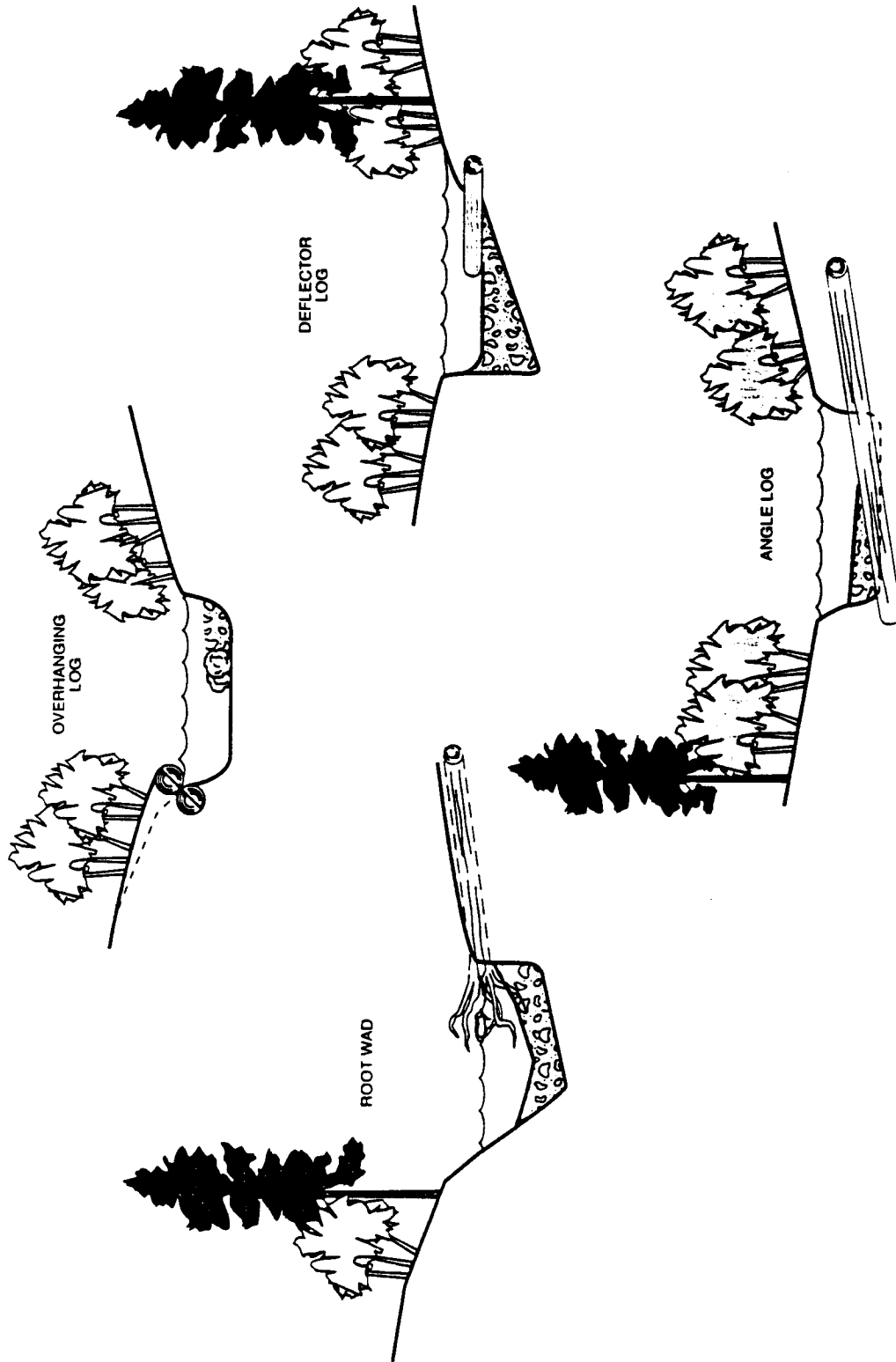
Fish Access

Adequate fish access throughout the entire relocated stream section will be provided by the minimum design depth requirements (i.e., 0.25 ft during dry season base flows). Accessible habitat includes protected areas (i.e., low-velocity pockets) during high flows. The channel is also designed to avoid habitat features that could cause stranding problems during low-flow conditions.

This minimum depth requirement should allow fish access to habitat throughout the length of the channel, thus limiting stranding problems during low-flow periods.

Stable Flow

Stable flows ensure habitat access and protect the habitat against erosion or scouring; they also minimize fish displacement to less preferred habitats. The channel width and bank slope criteria incorporated in the design will help maintain relatively stable flow velocities throughout the range of flows expected in the new channel.



Data Compiled by Parametrix

Port of Seattle/Natural Resource Mitigation Plan/556-2912.001/01(03) 12/00 (K)

Figure 5.1-4
Representative Fish Habitat
Enhancement Features

Stream Substrate

Cutthroat trout require stable gravel and sand substrates largely free of accumulated silt for spawning and during early rearing life stages. This substrate also contributes to the optimum production of desired prey. Substrate in the relocated channel will consist of gravel, coarse sands, and cobble material to provide stable spawning and rearing habitat. However, portions of the channel will naturally accumulate sand over time. The flow velocity criteria for the channel were set to maintain suitable substrate for fish by minimizing the accumulation of fine-grained material in the channel during low-flow periods and preventing excessive scouring of the substrate during high flows. Since flow velocities are not constant along the entire channel, sedimentation is expected to occur on the inside of bends and in deeper pools during low-flow periods. However, these sediments will flush out again during higher flows.

Floodplain Conveyance

The 100-year floodplain elevation and floodway delineation in the proposed project area were determined by FEMA when the Flood Insurance Rate Maps (FIRM) were prepared. The proposed channel capacity was checked for the 100-year flow rate peak capacity. No impacts are expected to flood conveyance since the floodplain storage does not decrease (see Section 5.1.2) and the floodplain has adequate capacity to convey the 100-year flood.

Channel Planting and Riparian Buffer

The new channel banks will be stabilized and cover will be provided to the stream by planting the banks with native willows. A forested buffer will also be planted along the stream riparian zone to maximize stream shade and provide overhanging cover as habitat. These planting plans are described in Section 5.1.2.8. Upland trees and shrubs will also be planted on the roadway slope east of the new channel. These plantings will buffer the stream from the road but no mitigation credit will be sought for this area (Appendix A, Sheet C1.1).

5.1.1.7 Implementation

Construction of the third runway, which requires the relocation of Miller Creek, is currently scheduled as part of the first phase of the proposed Master Plan Update implementation. Channel relocation construction is currently anticipated to begin the first construction season (i.e., summer) following granting of the permits for the project. After the new channel is complete, Miller Creek will be diverted and monitoring will begin. Instream work associated with new channel construction must occur during low flow periods and be consistent with Hydraulic Project Approval (HPA) permit conditions as specified by WDFW. Construction of the channel relocation will be coordinated with construction of the third runway, South 154th Street/South 156th Street relocation, the sewer line relocation, and construction of Vacca Farm floodplain projects. A detailed description of implementation, construction methods, and construction steps for the Vacca Farm projects, including the stream relocation, is included in Section 5.1.4.

5.1.1.8 Monitoring and Performance Standards

The Miller Creek relocation project will be monitored consistent with the approach and schedule outlined in Chapter 4 of this document. Detailed performance standards and contingency measures

for the Miller Creek channel are included in Table 5.1-7, which summarizes performance standards and monitoring methods and parameters for all of the Vacca Farm mitigation projects. The general monitoring schedule for the Vacca Farm projects is provided in Table 5.1-8. Monitoring of the new channel includes routine inspections and emergency inspections following major floods.

Hydrology and Hydraulics

The effectiveness of the relocated stream will be evaluated in several ways. Because erosion and sedimentation are the primary indicators of stream hydraulic conditions, they are the critical criteria to be included in the proposed monitoring plan. The following activities will be included in the stream monitoring plan to determine whether specific performance standards are being met (see Tables 5.1-7 and 5.1-8):

- Inspect the constructed habitat features (log weirs, root wads, etc.) to ensure that they have not been damaged or displaced (to the extent that they are not providing habitat).
- Inspect the substrate to ensure that sedimentation and erosion prevention goals are met.
- Inspect for erosion or scouring.
- Evaluate substrate material to determine if particle sizes remain stable, and there is no evidence of excessive siltation or scouring.
- Inspect stream structures and channel after major storms, as monitored by the KCSWM gage.
- Inspect for adverse flooding impacts and ponding water.

The site perimeter of all mitigation sites will be protected by fencing approved by the ACOE. Site perimeters will also be marked by permanent signs that clearly designate the area as a protected wetland mitigation site. Signs will be inspected regularly and maintained in good condition by the Port.

Channel Bank and Riparian Buffer

Vegetation along the new channel will be monitored to ensure that channel and riparian plantings meet design goals and become successfully established along the relocated stream. Performance standards, variables to be evaluated (e.g., survival, cover), and specific contingency measures for riparian vegetation are included in Table 5.1-7.

Instream Habitat

Instream habitat conditions in the relocated channel section will be described based on a variety of monitoring data collected using standard methods for ecological evaluations of streams. Hydrologic conditions important to habitat that will be described include water depths, velocities, profile and area of wetted channel. Substrate conditions (size and type) will be evaluated and described by site observations and pebble counts. The amounts and types of large woody debris in the stream channel will be described, including the special habitat conditions (undercut banks, side channels, and pools) this large woody debris creates. The influence of riparian vegetation on instream habitat will be described based on surveys of plant cover overhanging the high and low flow channels. Methods for collecting and evaluating this information are provided in Table 5.1-8.

Table S.1-7. Final performance standards, evaluation approaches, and contingency measures for mitigation projects at Vacca Farm.

Design Criteria	Performance Standard	Evaluation Approach	Contingency Measures ¹
Relocation of Miller Creek			
Construct low flow channel 8 feet wide with 1:1 slopes and 0.5 ft deep to convey summer base flows.	Maintain at least a minimum dry season water depth of 0.25 ft (at about 0.5 cfs).	Dry and wet season measurements of water depths and velocities.	Evaluate factors responsible for not meeting performance standards.
Construct high flow channel 32 feet, side slopes of 2:1 (typical) from depths of 0.5 to 1.0 ft to provide capacity for wet season base flow.	Wet season (October to April) average base flow depth is approximately 1 ft (at 5 cfs).	Survey of constructed channel cross sections and flow measurements.	Adjust channel low flow depth or channel bottom width using habitat features such as logs, boulders, root wads, etc. or regrading channel if necessary.
The channel cross section will provide an average dry season base flow velocity that is greater than the silt transport velocity (0.7 ft/sec).	Flows during most low flow periods will exceed 0.7cfs.	Dry and wet season velocity measurements.	Reduce width of low-flow channel using woody debris or boulders.
Design a natural channel with stable gravel bottom.	Riffle substrate will be composed of substrate suitable for spawning of cutthroat trout with no greater than 20% fine sediments (i.e., sand or smaller).	Volumetric assessment of substrate (eg. McNeil core or bulk sample) to document substrate conditions.	Re-grade if constructed channel does not meet performance standard. If fine sediments are present, evaluate sources and potential stabilization methods to control or eliminate.
Channel flow velocity cannot exceed the gravel movement velocity (4 ft/sec) for the 100-year flow.	Bed material shall be spawning size gravels appropriate for cutthroat trout; bed material size will not increase significantly compared to as-built conditions. Scoured channel bottom sections, if present, shall not exceed 10 linear feet.	Volumetric assessment of substrate (eg. McNeil core or bulk sample) to document substrate conditions. Velocity measurements. Channel survey to evaluate evidence of scouring or erosion.	Adjust stream bottom width to increase velocity (using woody debris or boulders). Adjust width of channel, replace spawning gravels, and repair any eroded channel banks with bioengineering or additional streambank planting
Flows greater than the annual peak flow will overtop the channel and inundate the adjacent floodplain restoration.	Flows greater than the annual peak flow of about 40 cfs will overflow the streambanks.	Measure water elevations in floodplain and relate to gauged stream data.	Adjust bank height, channel morphology, or roughness to alter amounts of overbank flow. Regrade if necessary.
Provide a natural channel configuration. Increase channel length by about 10 percent and a meandering low flow channel.	Channel has pool/riffle morphology for about 1,080 feet in length. Baseflow channel is non-linear.	Review record drawings for as-built condition. Monitor channel condition.	Reconstruct to conform to required design.

Table 5.1-7. Final performance standards, evaluation approaches, and contingency measures for mitigation projects at Vacca Farm (continued).

Design Criteria	Performance Standard	Evaluation Approach	Contingency Measures ¹
Provide habitat features, including instream features such as deflectors and overhanging logs as needed to maximize available habitat.	Meets design criteria for channel habitat features (e.g., LWD, overhanging logs, deflector logs, undercut banks). Density or abundance of habitat features should remain stable or increase compared to as-built conditions.	Measure abundance, sizes, and location of LWD in the new channel.	If losses of LWD occur, evaluate factors contributing to reduction in LWD (e.g., high flows) and address. Add LWD to channel as necessary.
Provide approximately 3.0 acres of vegetated buffer on the east side of the channel. Establish native vegetation along channel banks and the riparian zone of the new channel.	Establish 3.0 acres of native shrub/forested riparian zone and upland buffers with an average tree density of at least 280 stems/acre and shrub density of at least 2,100 individuals per acre in the first 3 monitoring years. Average survival of planted trees and shrubs in the first 3 monitoring years shall be at least 80%; cover of native species will be 80% by year 10. Cover of non-native invasive species will be no greater than 10% by monitoring year 10.	Vegetation sampling (plots, transects, or plotless techniques) to measure stem density plant cover, count live and dead plants and measure cover of exotic species.	Install additional plants if necessary. Identify substitute native species that are adapted to site conditions. Eliminate or reduce the abundance of non-native invasive species. Install protective collars to reduce herbivore damage.
Densely plant woody vegetation along the new channel to cover open water and reduce use of the area by waterfowl.	Canopy coverage over the stream channel will be 80 percent by the end of the 10-year monitoring period.	Vegetation sampling to determine tree and shrub cover.	Add additional plants if areas of exposed stream channel are present.
Wetland Enhancement and Restoration	Excavate approximately 9,600 cy of soil between elevation 262 ft and 266 ft. Excavate drainage swales to provide positive drainage from the floodplain and prevent standing water during non-flood periods. Floodplain grades will slope towards drainage swales which connect to Miller Creek.	Record drawings and hydrologic monitoring.	Regrade area if not excavated to specifications. Modify design of swales to improve drainage conditions if necessary.

Table 5.1-7. Final performance standards, evaluation approaches, and contingency measures for mitigation projects at Vacca Farm (continued).

Design Criteria	Performance Standard	Evaluation Approach	Contingency Measures¹
Use excavated material from grading the secondary swales to create topographic variation in the floodplain.	Topographic features (mounds, ridges) will be constructed at a density of approximately 4 per acre.	Determine density from record survey.	Construct additional features if project has not been built to specifications.
Eliminate farming activities and remove existing structures from restoration site.	Farming leases and activities will be terminated. All structures will be removed from the site.	Record reviews to verify restrictive covenants prohibit farming.	
Remove ditches and drains. Grade floodplain to elevations that restore wetland hydrology.	Groundwater/soil saturation levels in the floodplain wetlands will demonstrate saturation near the surface during March through May during years of normal precipitation.	Hydrologic monitoring using shallow wells Compare changes in hydrology to rainfall trends.	Modify grading, drainage swales, or channel configuration to decrease or promote soil saturation.
Restore and enhance approximately 9.24 acres of farmed wetlands, wetland, and prior converted cropland in the floodplain and wetlands around Lora Lake with native vegetation. Enhance approximately 1.8 acres of floodplain and Lora Lake shoreline buffer with native vegetation (see Table 5.1-1). Plant native shrub species at densities of approximately. Intersperse native trees in this area. Shrubs will be planted at a density greater than 2,100 per acre.	The restoration area will be a minimum of 11 acres. Shrub and tree survival will average at least 80% in the first 3 monitoring years. At that time, at least 2,100 shrubs/acres will remain. Percent canopy cover of native species will be at least 80% by year 10. Non-native invasive species cover will be no more than 10% by year 10 in newly planted areas. By the end of year 3, plant diversity in each stratum will not decrease by more than 10% from the number and type of plants installed at baseline.	Determine area from record survey. Vegetation sampling (plots, transects, or plotless techniques) to estimate mortality. Vegetation sampling (plots, transects, or plotless techniques) measure cover. Vegetation sampling (plots, transects, or plotless techniques) to estimate canopy cover	Modify construction if not built as specified. If standards are not met: <ul style="list-style-type: none"> Select species that are better adapted to existing hydrologic conditions. Install additional plant material. Install protective collars to reduce herbivore damage. See above. Install additional plant material. Install protective collars. Control/reduce non-native invasive species.
Plant the floodplain with native trees, shrubs, and tall grasses (see Table 5.1-1 and 5.1-12) to deter waterfowl.	Percent canopy cover of native species will be at least 80% by year 10.	Vegetation sampling (plots, transects, or plotless techniques) to estimate canopy cover	See above.

Table S.1-7. Final performance standards, evaluation approaches, and contingency measures for mitigation projects at Vacca Farm (continued).

Design Criteria	Performance Standard	Evaluation Approach	Contingency Measures¹
Enhance existing forested wetland south of Lora Lake with native trees and shrubs. Total density of planted material will be greater than 250 stems/acres (trees) and 1,700 individuals per acre (shrubs).	Percent canopy cover of native species will be at least 80% by year 10.	Vegetation sampling (plots, transects, or plotless techniques) to estimate canopy cover	See above.
Lora Lake Buffer Enhancement			
Plant a 25-ft buffer (0.60 acre) around Lora Lake with native trees and shrubs.	Lora Lake will have a 25-ft wide (0.60 acres) protected by restrictive covenants.	Verify records to assure covenant is in place.	Remove remaining structures if not completed per design.
All structures within the 25-ft buffer will be demolished and failing septic systems (if present) will be removed shrubs.	Record drawings and photo documentation verify that no structures remain within the buffer area around Lora Lake.	Record drawings and site inspections.	Contingency measures for vegetation performance standards are described above.
Plant native tree species at densities of greater than 280 per acre. Plant native shrub species at densities of greater than 2,100 per acre.	Average survival of planted stock will be at least 80% in the first 3 monitoring years. At the time at least 280 trees per acre and 2,100 shrubs per acre will remain.	Vegetation sampling (plots, transects, or plotless techniques), as described above.	
	Percent canopy cover of native species will be at least 80% by year 10.		
	By the end of year 3, plant diversity in each stratum will not decrease by more than 10% from the number and type of plants installed at baseline.		
	Non-native invasive species cover will be no more than 10% by year 10 in newly planted areas.		
Concrete bulkhead will be removed and shoreline graded to a stable slope configuration.	Record drawings and photo documentation verify that the concrete bulkhead has been removed.	Record drawings to verify removal and bulkheads and slope of shoreline.	Remove all structures and bulkhead areas to be consistent with design. Re-grade as necessary to be consistent with design.
	New shoreline of Lora Lake will have a slope of 3:1 or less.		

¹ For all performance standards, monitoring periods may be extended if performance standards are not met.

Table 5.1-8. Miller Creek relocation mitigation monitoring methods and schedule.

Feature	Activity	Duration	Years Following Construction										
			0	1	2	3	4	5	6	7	8	9	10
Habitat Structures	Visual inspection, photodocumentation	Annually (May), or after flows in excess of the 2-year peak flow (during the first 3 years)	X	X	X	X		X		X		X	X
Channel Morphology	Measured cross sections, longitudinal profiles, photodocumentation	Annually (May), or after flows in excess of the 2-year peak flow (during the first 3 years)	X	X	X	X		X		X		X	X
Substrate	Pebble counts	Semi-annually (February/August)	X	X	X	X		X		X		X	X
Erosion or Scouring	Evaluate materials and scouring	Annually (May), or after flows in excess of the 2-year peak flow (during the first 3 years)	X	X	X	X		X		X		X	X
Adverse Flooding	Inspect floodplain for ponded water	Twice yearly (February/ November)	X	X	X	X		X		X		X	X
Channel Plantings	Vegetation sampling	Semi-annually (May/June & September/October)	X	X	X	X		X		X		X	X

5.1.1.9 Site Protection

The Port will execute and file restrictive covenants on the mitigation projects at Vacca Farm site. Copies of restrictive covenants that have been approved by the ACOE, Ecology, FAA, and U.S. Department of Agriculture – Wildlife Services Division (USDA-WSD) are included in Appendix F.

5.1.1.10 Maintenance and Contingency Plans

A key design objective for the stream channel is that it shall function as a natural channel, requiring little or no maintenance. To ensure that this goal is achieved, the monitoring plan and contingencies have been designed to allow the channel to perform within a range of conditions. If the performance standards indicate that the channel is not within this acceptable range, periodic maintenance may be required to change or remove the factors responsible. Specific contingency measures for the channel relocation are included in Table 5.1-7.

The proposed channel configuration has two basic conveyance criteria that need to be maintained to meet performance standards: (1) maintain minimum flow depths and velocity for fish passage, water quality, and sedimentation; and (2) provide flow capacity for peak flows. If there were to be future changes in flow rates in Miller Creek compared to design flows, contingency measures may be required for the project to continue to meet goals and objectives. The Port does not anticipate that contingency measures will be needed due to future changes in flow rates for the following reasons. Flow rates are unlikely to differ from the design flows used to develop this plan because the design flows were derived from detailed data (including a calibrated HSPF model), and because

of the extensive stormwater management plans developed for the project (see Chapter 6 and Parametrix 2000a). Possible contingency measures that would be implemented in the case of altered flow rates could include:

- Widening the base flow channel to reduce velocities and improve capacity
- Narrowing the base flow channel with logs or boulders to increase base flow depth and velocity
- Widening the flood flow portion of the channel (above 0.5 ft) to improve capacity and reduce velocity
- Adding log weir steps to flatten stream slope, reducing velocity and increasing base flow depth
- Adding a bypass flow channel to convey peak flows past the main channel.

5.1.2 Vacca Farm Floodplain and Wetland Restoration Plan

To mitigate for wetland impacts and the loss of floodplain storage (approximately 5.24 acre-ft) and wetland impacts in the Miller Creek basin, the floodplain and wetlands in the Vacca Farm area will be restored (see Table 5.1-1). Restoration of the historic floodplain and wetlands will include providing approximately 5.94 acre-ft of flood storage, restoring wetland hydrology, and re-establishing native vegetation in approximately 12 acres of existing cultivated farmland and aquatic habitat of Lora Lake. Existing degraded wetlands on the Vacca Farm site will be enhanced by replacing non-native vegetation with native plant communities. Functions in the restored wetlands will be further enhanced by planting forested upland buffers around the perimeter of the Vacca Farm site (Figure 5.1-5). Approximately 5 acres of upland buffers will enhance and protect the floodplain wetlands by increasing infiltration and supporting wetland hydrology and stream base flows, removing sediments and nutrients, and providing physical protection and visual screening from adjacent properties. The Vacca Farm mitigation allows significant wetland functional restoration to occur in proximity to, and in the same basin as, project impacts.

Vacca Farm contains areas which historically were wetland but have altered hydrology due to prior agricultural activities. The floodplain and wetland restoration would restore wetland hydrology to the site by removing existing drainage features and excavating part of the floodplain to bring seasonal groundwater levels closer to the surface. Native wetland plant communities will be restored to the floodplain wetlands and existing degraded emergent wetlands will be enhanced to forested or shrub wetlands (see Figure 5.1-5). These actions will enhance hydrologic (i.e., surface water storage) and water quality functions at the Vacca Farm site, as well as reduce the volume of eroded soil, pesticide and fertilizer runoff reaching Miller Creek.

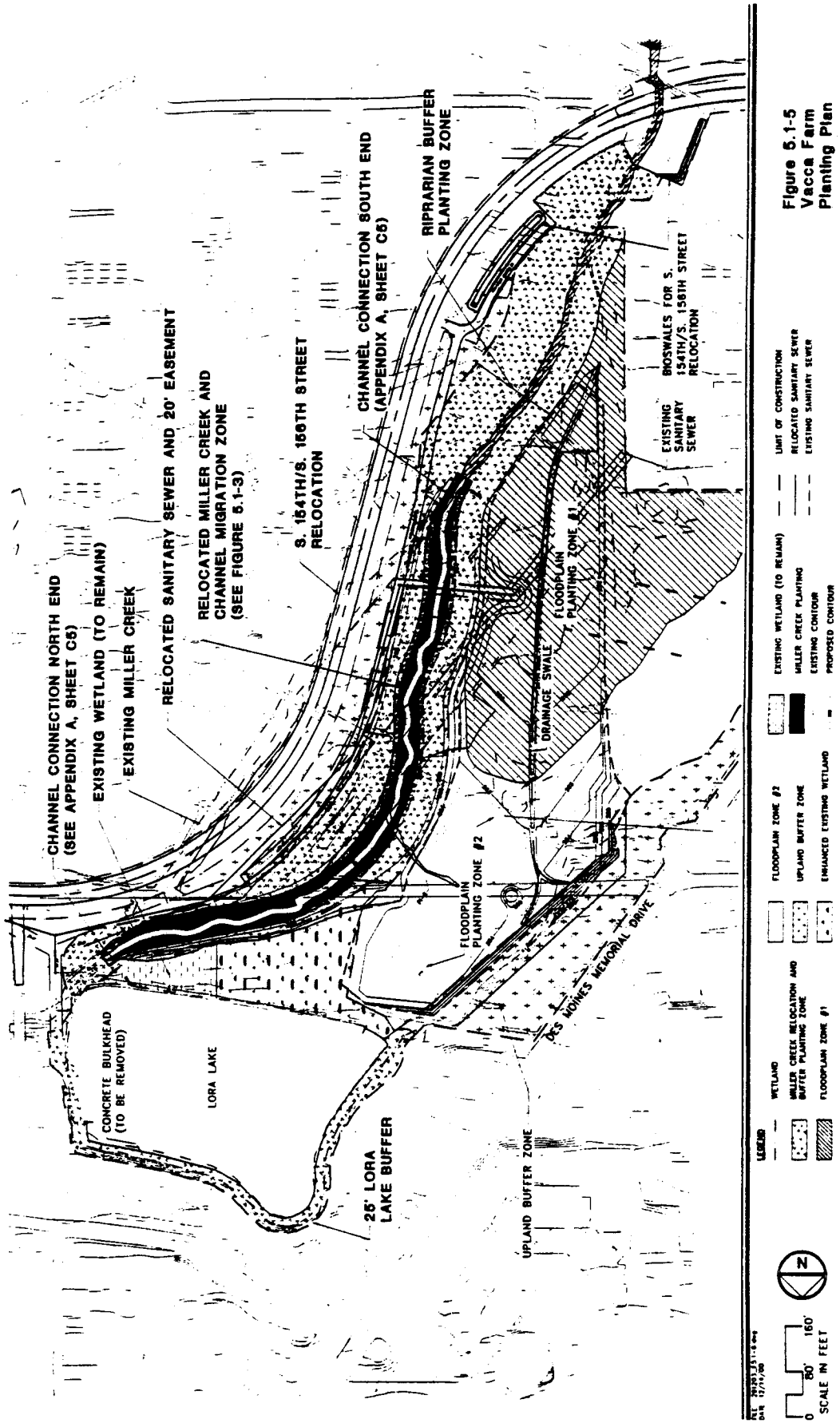


Figure 5.1-5
Vacca Farm
Planting Plan

To protect aquatic habitat in Miller Creek and to protect and enhance functions of floodplain wetlands, forested buffers will be established and enhanced. An upland buffer area will be established along the east side of the relocated Miller Creek between the riparian zone of the stream and the relocated roadway for South 154th Street (Figure 5.1-6; and see Figure 5.1-5). The buffer will reduce human intrusion into the riparian zone, screen riparian habitats from human activity, and protect water quality and aquatic habitat. A second upland buffer will be established between the floodplain enhancement area and Des Moines Memorial Drive on the west side of the Vacca Farm site (see Figure 5.1-5). The forested buffer in this area will provide a physical buffer between the road and the enhanced shrub floodplain wetlands and restored stream.

5.1.2.1 Goals, Objectives, and Design Criteria

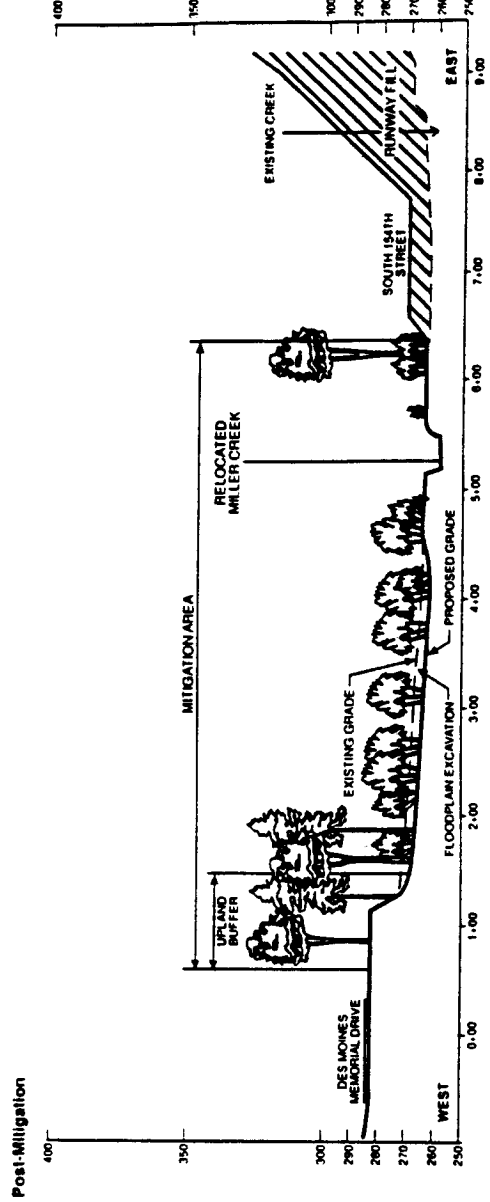
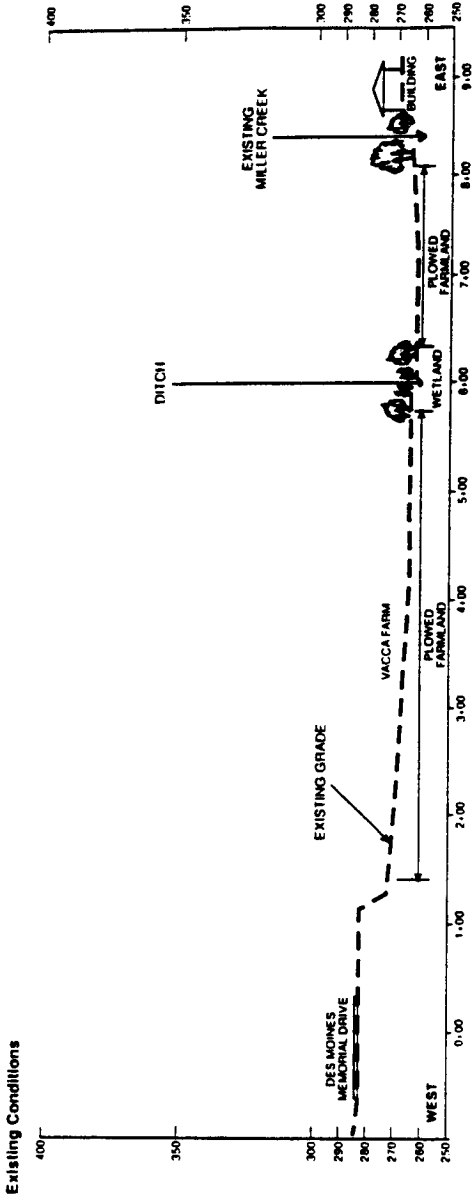
Three specific goals have been identified for the Vacca Farm floodplain and wetlands mitigation:

- Goal 1: Compensate for loss of floodplain habitat, flood storage, and wetlands in the Miller Creek basin.
- Goal 2: Restore and enhance floodplain and wetland functions adjacent to Miller Creek in the Vacca Farm site by restoring historic floodplain and wetland hydrology and vegetation. Enhance floodplain, wetland, and stream functions by providing forested riparian and upland buffers.
- Goal 3: Grade the floodplain and create a planting plan for the wetland community in the floodplain area that does not attract waterfowl and flocking birds, and reduces existing wildlife hazards.

Specific objectives and design criteria that have been developed to achieve these wetland mitigation goals are listed in Table 5.1-9.

5.1.2.2 Mitigation Site Description

The Miller Creek Floodplain and Wetland Restoration project will be located at the Vacca Farm site, northwest of the existing airfield. The Vacca Farm site includes Lora Lake and the area to the south of Lora Lake between the existing Miller Creek channel and Des Moines Memorial Drive (see Figures 2.1-2 and 2.1-4). Vacca Farm contains upland areas around the perimeter of the site, agricultural fields, some scattered farm structures, a system of drainage ditches and tile drains, farmed wetlands, and forested, shrub and emergent wetlands (Parametrix 2000c). A large ditch runs through the middle of the Vacca Farm site, parallel to the existing Miller Creek channel, flowing into Miller Creek at the south end of the site (see Figure 2.1-4).



Port of Seattle/Natural Resources Mitigation Plan/556-2912-001/01(03) 12/09 (K)

**Figure 5.1-6
Typical Cross Section of Miller Creek
Floodplain Enhancement**

VERTICAL SCALE 1" = 60'
HORIZONTAL SCALE 1" = 150'

Table 5.1-9. Mitigation goals, design objectives, and design criteria for the Vacca Farm wetland restoration project.

Goals and Design Objectives	Design Criteria
Goal 1: Compensate for loss of floodplain and flood water storage	
Provide additional floodplain area by excavating approximately 9,600 cy on the Vacca Farm site.	Excavate approximately 9,600 cy of soil between elevation 262 ft and 266 ft. Drainage swales to provide positive drainage from the floodplain and prevent standing water during non-flood periods. Use excavated material from grading the secondary swales to create topographic variation in the floodplain.
Goal 2: Increase functional linkages between historic wetlands and Miller Creek	
Remove existing agricultural uses from the floodplain area on the Vacca Farm site.	Eliminate farming activities and remove existing structures from restoration site.
Restore wetland hydrology to farmed wetlands and prior converted croplands.	Remove ditches and drains. Grade floodplain to elevations that restore wetland hydrology.
Plant floodplain with native trees and shrubs.	Restore 11 acres of floodplain (see Table 5.1-1) with native vegetation. Plant native shrub species at densities of approximately. Intersperse native trees in this area. Shrubs will be planted at a density greater than 2,100 per acre.
Goal 3: Create a planting plan for the wetland community in the floodplain area that does not attract waterfowl and flocking birds	
Deter flocking waterfowl, from using the site.	Plant the floodplain with native trees, shrubs, and tall grasses (see Table 5.1-11 and 5.1-12) to deter waterfowl.

5.1.2.3 Ownership

The Port owns all of the property on the Vacca Farm site.

5.1.2.4 Rationale for Selection

The Vacca Farm site allows significant wetland functional restoration to occur in proximity to, and in the same basin as, project impacts. Mitigation at this site provides the opportunity to restore wetland hydrology and wetland habitat to areas that historically were wetlands, but have altered hydrology due to prior agricultural activities. In addition, because the site has been farmed, the site is dominated by non-native plants, and there are no extensive areas of existing forest or invasive species, and the site is relatively flat. Therefore, minimal grading would be required, and natural vegetation communities would not be disturbed by mitigation activities. The floodplain and wetland restoration will also reduce wildlife hazards near the airport by replacing emergent wetlands with forested and shrub wetlands. These actions will enhance hydrologic (surface water storage) and water quality functions at the Vacca Farm site, as well as reducing the volume of eroded soil, pesticide, and fertilizer runoff reaching Miller Creek.

5.1.2.5 Constraints

No constraints have been identified that would preclude implementing this plan.

5.1.2.6 Ecological Assessment of the Vacca Farm Mitigation Site

Ecological conditions important to the mitigation design and implementation are summarized below. Historically the Vacca Farm site likely was a mosaic of forested and shrub wetlands. These wetlands developed on peat soils that formed in a wide floodplain along a low-gradient, frequently flooded reach of Miller Creek. The site currently consists of uplands, agricultural fields, farmed wetlands, and forested, shrub and emergent wetlands.

Miller Creek Floodplain

The 100-year floodplain in the vicinity of the Vacca Farm is quite extensive (see Figure 2.2-2). The wetland area and poor drainage that existed prior to agricultural drainage activities are evident from the 100-year floodplain estimated by FEMA. The approximate 100-year flood elevations, determined by FEMA as part of its study, vary from 266 ft at the Miller Creek detention facility outlet to approximately 265 ft at the downstream end of the Vacca Farm site. A floodway has also been delineated and mapped in a portion of the floodplain on the Vacca Farm site.

Hydrology

Wetland hydrology on the Vacca Farm site is supported primarily by high local groundwater levels, and secondarily by precipitation and overbank flooding in Miller Creek. Four groundwater-monitoring wells were installed at the Vacca Farm site on May 14, 1997 to evaluate site hydrology. Groundwater levels were then measured during 16 separate site visits between May 30, 1997 and November 12, 1997 (Table 5.1-10). During this period, groundwater levels averaged approximately 1.5 to 2 ft below the ground surface. The largest fluctuation occurred at monitoring well P-1, located in the existing forested and shrub wetland. At this well, the groundwater table was lowest during the dry summer months, and as expected, higher groundwater levels occurred in the spring and fall. For the past several years (1996 to 2000) during the winter and early spring months, the Vacca Farm site was temporarily flooded, and soils were saturated to the surface. These data were used to estimate hydrologic conditions expected to occur in the floodplain restoration site once drainage ditches are removed and excavation in the floodplain area is complete.

Soils

The Soil Survey for King County Area Washington (Snyder et al. 1973) has not mapped soils within the project area. However, Parametrix, Inc. and HWA GeoSciences, Inc. (1998) have evaluated existing soil conditions on the Vacca Farm site. Results of the soil investigations revealed that most of the soils on the site are underlain by soft, saturated peat that overlies layers of alluvial sands, silts, and dense, glacially deposited material. These conditions indicate that the area was largely a historic wetland that has now been partially drained and highly modified. Typical soil profiles in peat dominated areas on Vacca Farm are shown in Appendix A, Sheet C6.1. Soils in the upland areas on the Vacca Farm are predominantly silty loams with scattered inclusions of sandy loams.

Table 5.1-10. Groundwater monitoring well data¹ on the Vacca Farm site.

Sampling Date	Well Numbers and Surveyed Elevation (ft) ²			
	P-1 (263.7)	P-2 (265.1)	P-3 (262.9)	P-4 (273.1)
5/30/1997	-0.9	-2.0	-1.3	-2.5
6/05/1997	-0.5	-1.5	-0.4	-2.3
6/11/1997	-0.8	-1.8	-0.6	-2.3
6/19/1997	-1.0	-1.9	-0.7	-2.4
7/03/1997	-	-2.0	-0.6	-2.4
7/10/1997	-0.5	-1.6	-0.4	-2.3
7/25/1997	-2.0	-2.2	-1.3	-2.5
7/31/1997	-	-2.3	-1.6	-2.5
8/07/1997	-2.6	-2.4	-1.8	-2.5
8/14/1997	-2.7	-2.6	-2.1	-2.5
9/04/1997	-	-2.4	-1.8	-2.5
9/18/1997	-0.1	-1.1	-0.5	-2.2
9/26/1997	-1.0	-1.7	-0.5	-2.3
10/03/1997	-0.6	-1.2	-0.3	2.2
10/16/1997	-0.8	-1.6	-0.3	-2.2
11/12/1997	-0.5	-1.4	-0.2	-2.2

¹ Data are represented as depth to groundwater in ft.

² Elevations are represented as ft above mean sea level.

Upland Vegetation

Upland areas on the Vacca Farm site primarily consist of recently cultivated cropland; no native plant communities are present. Limited areas on the edge of the cultivated fields on the south and west side of the site are dominated by Scots broom (*Cytisus scoparius*), Himalayan blackberry, Canada thistle (*Cirsium arvense*), and various grass species such as orchardgrass (*Dactylis glomerata*) and common velvetgrass (*Holcus lanatus*).

The upland area in the southern portion of the site contains a gravel fill pad covered with various grass species and a dense Himalayan blackberry thicket. Some of the upland areas surrounding Miller Creek and drainage swales were created from side cast material from past dredging and maintenance activities in the stream and swales. Cultivated areas have been ditched and drained.

Farmed Wetland Vegetation

Nine farmed wetlands are present on the Vacca Farm site (FWs 1, 2, 3, 5, 6, 8, 9, 10, and 11; see Figure 2.1-4). Farmed wetlands are areas that contain wetland hydrology and soils, but lack wetland vegetation because of farming activities. Additional descriptions of the farmed wetlands

can be found in the *Wetland Delineation Report* (Parametrix 2000c). Due to the site's agricultural history, an extensive network of drainage ditches and tile drains exists on the site.

These areas have hydric soils and soil saturation within 12 inches of the soil surface for more than 15 consecutive days during the growing season. It is likely that these areas were wetlands before being converted to active farmland. However, these areas lacked inundation for at least 15 consecutive days during the early growing season and therefore do not meet the criteria for farmed wetlands according to the Food Security Act (Section 514.22).

Forested, Shrub, and Emergent Wetland Vegetation

A single large wetland (Wetland A1, approximately 4.66 acres) occurs in the central portion of the Vacca Farm site (see Figure 2.1-4). Wetland A1 is a forested, shrub, and emergent wetland complex located south of Lora Lake and extending south through the center of the Vacca Farm site. The northern portion of this wetland contains red alder and black cottonwood in the tree canopy with willow, hardhack, and common cattail (*Typha latifolia*) in the understory. A narrow band of Wetland A1 continues south and contains scrub-shrub and emergent wetland habitat that bisects the farmed agricultural fields. This wetland area is associated with a large north-south drainage ditch that parallels Miller Creek and ultimately drains into Miller Creek to the south (see Figure 2.1-4). Dominant species in wetlands associated with the ditch include Pacific willow (*Salix lucida*), Himalayan blackberry, common cattail, and reed canarygrass.

Wetlands A2, A3, and A4 are seasonally saturated shrub wetlands located in the center of the Vacca Farm site, in tilled farmland. These wetland islands are dominated by Himalayan blackberry with creeping buttercup (*Ranunculus repens*) around the edges.

5.1.2.7 Vacca Farm Floodplain and Wetland Restoration Design

This mitigation plan will replace lost flood storage by excavating approximately 9,585 cy of soil that is currently above the 100-year floodplain on the Vacca Farm site. This action will compensate for lost floodplain storage and wetland impacts from construction activities for the third runway fill embankment and portions of relocated South 154th Street. The farmed fields at the Vacca Farm site will be regraded to restore wetland hydrology and planted with native tree, shrub, and herbaceous plant species to restore the historic riparian/floodplain wetland. In addition, a portion of an existing forested, shrub, and emergent wetland (Wetland A1) will be enhanced by planting native shrubs in the area currently dominated by non-native blackberry species. Key elements of the mitigation design are presented below. Specific details on construction sequencing and construction methods for the project are included in the implementation section for Vacca Farm projects (Section 5.1-4).

Grading Design

Prior to grading, existing structures and fences will be removed from the site and existing ditches and drains will be filled or removed to restore site hydrology. The mitigation design objectives for the floodplain grading will be achieved by excavating and grading approximately 6 acres of the Vacca Farm site between elevations 262 and 266. An initial step will be to remove the top 6 inches of topsoil where floodplain grading will occur to remove potential pesticide residues from past farming activities. This soil will be disposed of off-site at an approved upland disposal facility.

To prevent water from accumulating on the new floodplain surface and potentially attracting waterfowl, a primary drainage swale with secondary side channels will be graded through the middle of the floodplain. The primary channel will be centrally located and approximately 1 to 2 ft wide. Side cast material from creating these channels will be incorporated into the site grading plan to create microtopographic relief. Microtopography will consist of mounds and ridges at a density of approximately 4 features per acre. Depressional areas will not be created due to the potential for attracting hazard wildlife. This microtopographic relief provides habitat complexity that will increase the diversity of plant species that can be supported on the site (Appendix A, Sheet C7.1). Large woody debris will also be added to the floodplain to increase habitat complexity and increase organic matter on the floodplain (Appendix A, Sheet C1.1).

Immediately after grading, the two floodplain wetland planting zones (see Figure 5.1-5) will be hydroseeded with a native grass mix to establish understory plants in these zones. All other areas that have been graded will be hydroseeded with a seed mixture designed to prevent soil erosion and sedimentation to Miller Creek and/or Lora Lake (Table 5.1-11). The seed mixture will stabilize any exposed soils that will not be brought to final grade or permanent vegetation cover within 30 days of exposure. This seed mix should be applied during the period between April 1 through June 30 and September 1 through October 31. If seeding occurs between July 1 and August 31, irrigation may be required to ensure germination and establishment.

Table 5.1-11. Proposed seed mix for erosion control.

Scientific Name	Common Name	Percent by Weight
<i>Agrostis alba</i>	Redtop	10
<i>Lolium multiflorum</i>	Annual rye	40
<i>Festuca rubra</i> var. <i>commutata</i>	Chewings red fescue	40
<i>Trifolium repens</i>	White clover	10

All soils left exposed for greater than 48 hours from October 1 through March 31 (or greater than 7 days from April 1 through September 30) will be covered with jute matting, or other appropriate BMPs.

As described above, soils at the Vacca Farm site consist primarily of peat and some mineral topsoil. Therefore, it is anticipated that soil amendments will not be necessary after grading activities occur. To the extent practicable, existing organic soils (below the top 6 inches) and sands from the site will be used to create a suitable planting medium, and match the proposed final graded surface (Appendix A, Sheet C6). Where use of existing organic soils is not practicable, a prepared topsoil will be tilled into the subgrade and match proposed graded surface prior to planting. Newly graded slopes will be tracked at right angles to the contour to reduce soil erosion.

Temporary irrigation will be installed following grading to provide flexibility in plant installation and to maximize successful establishment, survival, and early growth of hydroseeded cover crops and plant stock. It is important to note that irrigation will not be used to provide site hydrology (see below), but to ensure success during the initial critical stages of plant establishment. The system will be designed so that above-ground portions can be removed after a few years, when the option to

use irrigation will no longer be needed. Irrigation will use municipal water purchased by the Port. Use of the irrigation system is described more fully in the Implementation section, Section 5.1-4.

Expected Hydrology

The high groundwater table throughout the Vacca Farm site suggests that post-construction hydrology will result in soils that are saturated to the surface from the onset of autumn rains through early summer (early to mid July). Standing water, ranging in depth from 2 to 6 inches, is also expected to occur for short periods during the fall, winter, and spring months. To deter waterfowl from using areas of standing water, dense shrub plantings will be located throughout the site. The upland zones may become saturated during some winter months in years of normal rainfall, but would likely be dry by early summer. Because of a high water table on the site, dewatering may be necessary before grading activities occur (see Implementation Section, Section 5.1.4).

Wildlife Considerations

Flocking birds, raptors, and waterfowl pose the greatest concern for aircraft safety at STIA. Therefore, a landscape planting approach has been developed to aid in deterring these species from using the new mitigation sites as foraging areas or roost sites. Guidance obtained from Port wildlife managers and information gathered through literature searches have directed development of the overall landscape planting plan. For example, Lyon and Caccamise (1981) found that roost stands for European starlings were generally composed of deciduous trees 18 to 35 years of age with stem densities greater than 290 trees per acre (average of about 700 trees per acre). The minimum roost size was 0.32 acre, although the average was about 4.5 acres. Conclusions from this study indicate that these birds typically select roost sites composed of dense stands of young trees that allow the birds to roost in a compact formation, and also provide some thermal protection after leaf fall.

Waterfowl typically prefer to forage in open areas, such as open water, emergent marshes, or mowed lawn, because their view of potential predators is unobstructed. An obstructed view is perceived as dangerous and waterfowl will not typically forage in such an area. Therefore, the planting plan will focus on installing dense shrubs with scattered small trees to obstruct views and landing paths. This strategy will also exclude waterfowl during the winter by creating a dense barrier of stems to cover standing water that is likely to be present.

Geese or waterfowl exclusion measures will likely be necessary during the initial years of the mitigation because the site will be dominated by low vegetation and will be fairly open. Geese exclusion measures will include dense planting of trees and shrubs on the restoration site and the elimination of areas of open, ponded water. During the monitoring period, geese exclusion may also include physical barriers to prevent geese from landing or entering the site.

Landscape Plan

Planting Plan

Six planting zones will be created in the Miller Creek floodplain enhancement and wetland restoration area: Upland Buffers, Existing Wetland Enhancement, Floodplain Zone 1, Floodplain Zone 2, Miller Creek Riparian Buffer, and Miller Creek Channel Planting (see Figure 5.1-5; and Table 5.1-11; Appendix A, Sheet L1). To minimize wildlife hazards, all the planting plans for the

in-basin mitigation actions are designed to be unattractive to flocking birds and waterfowl. Plants used in the in-basin mitigation areas (Table 5.1-12) produce few fruits, berries, or nuts.

Upland Buffers

Upland Buffers (see Figure 5.1-6; Appendix A, Sheet L1) are located east and west of the floodplain area, and will be planted with species adapted to seasonally wet, upland soil conditions. Upland buffers will typically be located above the 100-year floodplain (approximately at the 265-ft elevation). The landscape plan for the upland area will focus on planting trees and shrubs in a dense vegetated buffer to protect the floodplain enhancement area from surrounding land uses. Installed tree densities will be at least 280 stems per acre. Trees will be installed according to the planting plan and field locations will be approved by the landscape architect or wetland biologist. Installed shrub densities will be greater than 2,100 individuals per acre (see Table 5.1-7). The planting scheme in the upland areas will place coniferous and deciduous tree species in patches to create a broken canopy.

Existing Wetlands to be Enhanced

Existing wetlands on the Vacca Farm site will be enhanced by removing non-native invasive species in selected areas and infill planting with native tree and shrub species. A portion of Wetland A1, south of Lora Lake, contains an area that historically has been disturbed by agricultural and other activities. As a result of this disturbance, non-native invasive species such as Himalayan blackberry have become dominant in this portion of the wetland. Therefore, an enhancement plan has been developed for this area to promote a native wetland vegetation community. Patches of blackberry will be removed and the wetland will be planted with native small tree and shrub species (primarily willows) to create a native shrub/tree community and to reduce cover of non-native species. Planting densities for infill tree planting will be greater than 250 stems per acre and for shrub planting will be greater than 1,700 individuals per acre. Infill planting densities are slightly lower than planting densities in cleared and/or graded areas because some native vegetation already exists in areas to be infill planted.

Floodplain Wetlands (Planting Zone 1 and Planting Zone 2)

Floodplain wetlands will be restored to native small tree and shrub wetland plant communities following grading. The landscape plan for the wetland floodplain restoration area will be similar to that described above with regard to wildlife attractants. Shrubs will be planted in dense patches to provide continuous shrub cover, with western redcedar and some deciduous trees on microtopographic high points interspersed in the shrub planting (Figure 5.1-7). Floodplain Zone 1 is the wettest zone on the floodplain and will be planted with species tolerant of the prolonged saturation and periods of inundation that will occur below elevation 262.5 ft. Floodplain Zone 2 will be slightly drier than Zone 1 and will consist of wetland plant species tolerant of the wet and saturated soil conditions that occur between elevations 262.5 ft and 265 ft. Figure 5.1-6 and Sheet C1.2 in Appendix A show a typical cross section of the Vacca Farm floodplain following grading and planting.

Table 5.1-12. Proposed plant list for mitigation projects in Miller and Des Moines Creek basins.

Scientific Name	Common Name	Size and Condition ¹	Approximate Spacing (ft/oc) ²	Approximate			
				Upland Zone	Floodplain Zone 1	Floodplain Zone 2	Riparian Zone
Trees							
<i>Abies grandis</i>	Grand Fir	3 - 4' B&B	10 to 15	X			
<i>Acer macrophyllum</i>	Bigleaf maple	3 - 4' B&B	10 to 15	X		X	X
<i>Alnus rubra</i> ³	Red alder	3 - 4' D&B	10 to 15	X			X
<i>Fraxinus latifolia</i>	Oregon ash	3 - 4' D&B	10 to 15		X	X	X
<i>Picea sitchensis</i> ³	Sitka spruce	3 - 4' B&B	10 to 15	X		X	
<i>Populus trichocarpa</i>	Black cottonwood	3 - 4' B&B/live stake	10 to 15			X	X
<i>Pseudotsuga menziesii</i> ⁴	Douglas fir	3 - 4' D&B	10 to 15	X			
<i>Rhamnus purshiana</i>	Cascara	3 - 4' B&B	10 to 15			X	X
<i>Thuja plicata</i>	Western redcedar	3 - 4' B&B	10 to 15	X		X	
<i>Tsuga heterophylla</i>	Western Hemlock	3 - 4' B&B	10 to 15	X			
Shrubs							
<i>Acer circinatum</i>	Vine maple	2 gal	4 to 6	X			X
<i>Philadelphus lewisii</i>	Mock Orange	2 gal	4 to 6	X			
<i>Physocarpus capitatus</i>	Pacific ninebark	2 gal	4 to 6			X	X
<i>Rosa nutkana</i>	Nootka rose	2 gal	4 to 6	X			
<i>Rosa pisocarpa</i>	Clustered rose	2 gal	4 to 6			X	X
<i>Salix hookeriana</i>	Hooker willow	live stake ⁴	4 to 5		X	X	X
<i>Salix lucida</i>	Pacific willow	live stake ⁴	4 to 5		X	X	X
<i>Salix sitchensis</i>	Sitka willow	live stake ⁴	4 to 6		X	X	X
<i>Salix scouleriana</i>	Scouler's willow	live stake ⁴	4 to 5			X	X
<i>Spiraea douglasii</i>	Hardhack spirea	2 gal	4 to 5		X	X	
Grasses							
<i>Agrostis exarata</i>	Spike bentgrass	Seed			X		X
<i>Beckmannia syzigachne</i>	Slough grass	Seed			X		

5-37

Natural Resource Mitigation Plan
Seattle-Tacoma International Airport
Master Plan Update

December 2000
556-2912-001 (01) (03)

G:\DATA\working\3912513\W13010\happal\2000 NARMP\4\arcm\versions\Master_2.doc

AR 048716

Table 5.1-12. Plant list for mitigation projects in Miller and Des Moines Creek basins (continued).

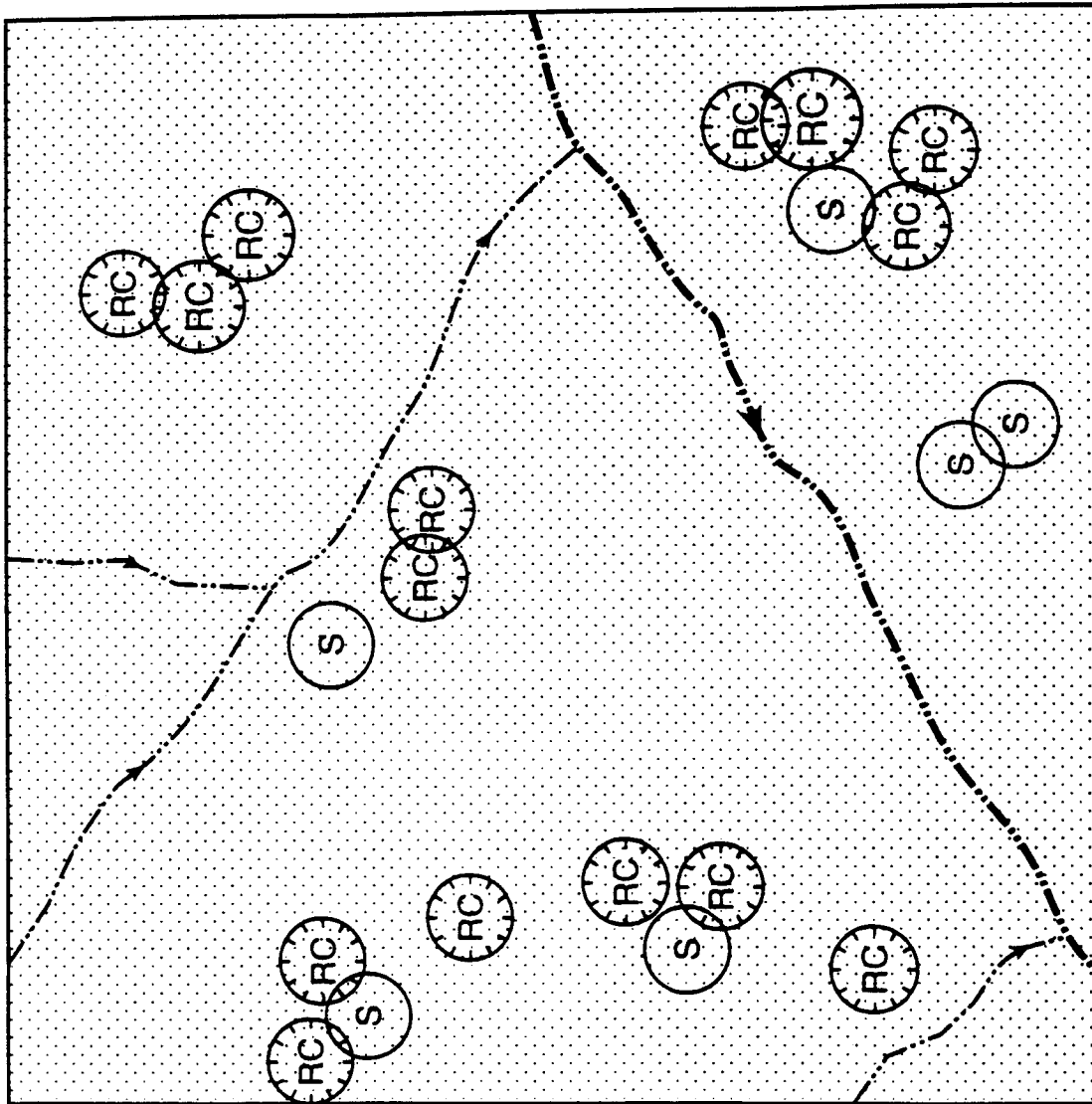
Scientific Name	Common Name	Size and Condition ¹	Approximate Spacing (ft/oc) ²	Upland Zone	Floodplain Zone 1	Floodplain Zone 2	Riparian Zone
<i>Calamagrostis canadensis</i>	Canada reed	Plug or seed	2	X	X	X	
<i>Deschampsia cespitosa</i>	Tufted hairgrass	Seed		X		X	
Sedges and Rushes							
<i>Carex amplifolia</i>	Ample-leaved sedge	Seed		X	X	X	
<i>Carex praticola</i>	Meadow sedge	Seed		X	X	X	
<i>Carex stipata</i>	Sawbeaked sedge	Plug/seed	2	X	X	X	
<i>Scirpus cyperinus</i>	Wool-grass	Seed		X	X	X	
Herbaceous							
<i>Aster subspicatus</i>	Douglas aster	Seed				X	X
<i>Solidago canadensis</i>	Canada goldenrod	Seed				X	X

¹ Depending on availability and season, plant condition may be substituted. B&B refers to ball and burlap.

² All shrub plantings for the Miller Creek floodplain wetland restoration, Miller Creek drainage channel replacement, and Tyee Valley Golf Course will be planted 3 to 4 ft on center.

³ These species will not be a dominant component of the planting plan in order to limit the potential to attract flocking birds.

⁴ Live stake material will typically be used in the Miller Creek relocation buffer planting and in other buffer/floodplain plans, where appropriate. Spacings for line stakes may range from 18 inches to 3 ft on-center.



- Sitka Spruce
- Western Redcedar
- Mixed Shrub
- Drainage Swale
- Secondary Drainage Swales

Note: See Appendix A Sheets L1 and L2 for details
 Part of Seattle/Natural Resource Mitigation Plan/556 2012 001/0103/ 12/00 (R)

Figure 5.1-7
 Typical Planting Plan for the
 Miller Creek Floodplain, Zone 2

Installed tree densities will be at least 280 stems per acre. Trees will be installed according to the planting plan and field locations will approved by the landscape architect or wetland biologist. Installed shrub densities will be greater than 2,100 individuals per acre.

Herbaceous understory species will be established in the two floodplain wetland zones by hydroseeding a native grass/sedge/forb mix in these zones in early fall, following grading (see Table 5.1-11). The hydroseed mix will contain seeds and a wood fiber mulch/tackifier to stabilize soils and enhance germination. Plant species included in the mix are designed to provide for rapidly germinating species that can provide initial cover, as well as later germinating species that will add to the cover and species diversity of the herbaceous vegetation of the floodplain communities.

Miller Creek Riparian Buffer and Channel Planting

In addition to the upland buffers along the northwest and east sides of the site, riparian buffers will be established along Miller Creek and around Lora Lake (see Figure 5.1-5; Appendix A, Sheets L1 and L2). Species proposed to be planted in the riparian buffer include black cottonwood, Pacific willow, Sitka willow, Scouler's willow, bigleaf maple, Oregon ash, red alder, Pacific ninebark, and vine maple. An average 50-ft buffer will be established on both sides of the relocated segment of Miller Creek, although in some areas, the buffer will be less than 50 ft wide due to the location of the embankment and South 154th Street/South 156th Way. The immediate channel banks of the newly relocated channel will be planted with live willow stakes (Appendix A, Sheets L1 and L2). A typical cross section of the proposed buffer area around Miller Creek appears in Figure 5.1-6 and in Appendix A, Sheet C1.2.

Planting Approach

Planting will occur whenever possible in late fall (October to November) or early spring (March or April), when soil moisture and plant conditions are optimal for installing plants. However, it may not always be possible or desirable to plant only during the winter months. For example, soils may be frozen or too wet at times during the winter months, limiting the amount of planting that can take place. Irrigation will be installed on the site to make it possible to plant during times of the year other than winter or early spring. Planting will take place during summer or early fall months only if irrigation is available. Trees of varying heights (between approximately 36 and 48 inches) will be planted to provide height diversity, and trees and shrubs will be planted in a mosaic of species and heights to simulate natural patchiness. Trees and shrubs will be planted at densities (see Table 5.1-12) sufficient to attain the performance standards in Table 5.1-7. A landscape architect or wetland scientist will be on-site to observe placement and installation of the plant material to ensure that plants are installed according to the planting plan and specifications.

To reduce potential competition with non-native species, mulch or landscape fabric will be placed around the base of trees and shrubs. Girdling or other damage from small or large mammal grazing will be reduced or prevented through the use of collars, or the stems of installed plant material may be painted with a mixture of pruning wax and a natural deterrent such as cayenne pepper.

5.1.2.8 Monitoring and Performance Standards

The Vacca Farm floodplain and wetland mitigation site will be monitored consistent with the approach and schedules outlined in Chapter 4 of this document. Specific performance standards and contingency measures for the Vacca Farm floodplain are included in Table 5.1-7. The general monitoring schedule for the Vacca Farm projects is provided in Table 5.1-8. Monitoring objectives specific to the Vacca Farm site are designed to evaluate the functioning of the relocated channel (discussed above in Section 5.1.1.8), floodplain hydrology, wetland indicators, and the establishment of the upland and wetland plant communities (Table 5.1-13). Monitoring for hazard wildlife will also be conducted at the Vacca Farm site, as described above in Chapter 4.

Floodplain Hydrology

Floodplain groundwater hydrology will be monitored at the Vacca Farm site for at least a 10-year period following completion of all mitigation construction. The primary purpose of monitoring groundwater levels is to verify that shallow groundwater continues to support wetland hydrology on the site, and that seasonal groundwater levels are sufficient to support the wetland plant communities planted on the site. Groundwater hydrology will be monitored at the Vacca Farm site consistent with the methods and approach outlined in Chapter 4 of this document.

Vegetation Monitoring

Vegetation will be monitored in all planting zones at the Vacca Farm site to verify that performance standards are being met, and to develop contingency measures as necessary (see Table 5.1-7, Table 5.1-13). Vegetation monitoring will be consistent with the approach, methods, and schedules provided in Chapter 4 of this document.

5.1.2.9 Site Protection

The Port will execute and file a restrictive covenant for the mitigation area. Copies of proposed restrictive covenants are included in Appendix G.

The perimeter of all mitigation sites will be protected by fencing approved by ACOE. Site perimeters will also be marked by permanent signs that clearly designate the area as a protected wetland mitigation site. Signs will be inspected regularly and maintained in good condition by the Port.

5.1.2.10 Maintenance and Contingency Plans

Routine maintenance tasks (e.g., maintaining irrigation systems, removing trash, mulching, mowing), and adaptive management contingency measures (e.g., re-planting, weed control) will be implemented consistent with the approach outlined in Chapter 4. If the Vacca Farm site does not meet performance standards during the monitoring period, contingency measures will be implemented using the adaptive management approach outlined in Chapter 4. Specific contingency measures are provided for each performance standard in Table 5.1-7.

Table S.1-13. Monitoring schedule for wetland restoration and floodplain enhancement at Vacca Farm.

Feature	Activity	Timing	Data Collection Year																	
			0	1	2	3	4	5	6	7	8	9	10							
Floodplain Storage	A topographic survey of the site.	Immediately after grading is complete	X																	
Hydrology	Measure the maximum depth and approximate duration of inundation.	Monthly	X	X	X	X														
		Once during winter, late spring/early summer, and fall					X	X	X	X	X	X	X	X	X	X	X	X	X	X
Establishment of Vegetation	Calculate percent plant survival.	Monthly	X	X	X	X														
		Once during winter, late spring/early summer, and fall					X	X	X	X	X	X	X	X	X	X	X	X	X	X
Achieve an early successional wetland plant community	Vegetation mapping. Measure tree/shrub cover.	Once late spring to early summer	X	X	X	X														
		Once in late spring to early summer					X	X	X	X	X	X	X	X	X	X	X	X	X	X
Photographic documentation and walk-through survey.	Photographic documentation and walk-through survey.	Once in spring	X	X	X	X														
		Once in late spring to early summer in year 3, 5, 7, 10					X	X	X	X	X	X	X	X	X	X	X	X	X	X

Meeting the performance standards for non-native invasive species at Vacca Farm will likely require implementation of contingency measures during the 10-year monitoring period. Potential invasive species of concern at the Vacca Farm site include, but are not limited to, reed canarygrass, Himalayan blackberry, Japanese knotweed, and purple loosestrife. These species are a concern because they already occur at Vacca Farm and may be difficult to eliminate, or because propagules of these plants are likely to continuously re-invade the site from upstream aquatic sources or from the surrounding area. Successfully establishing native vegetation on the site will be a key component in reducing and controlling invasive species in the long term at the mitigation site. In the short term (i.e., during the 10-year monitoring period), contingency measures specified in Table 5.1-7 will be implemented as necessary to control invasive species on the site.

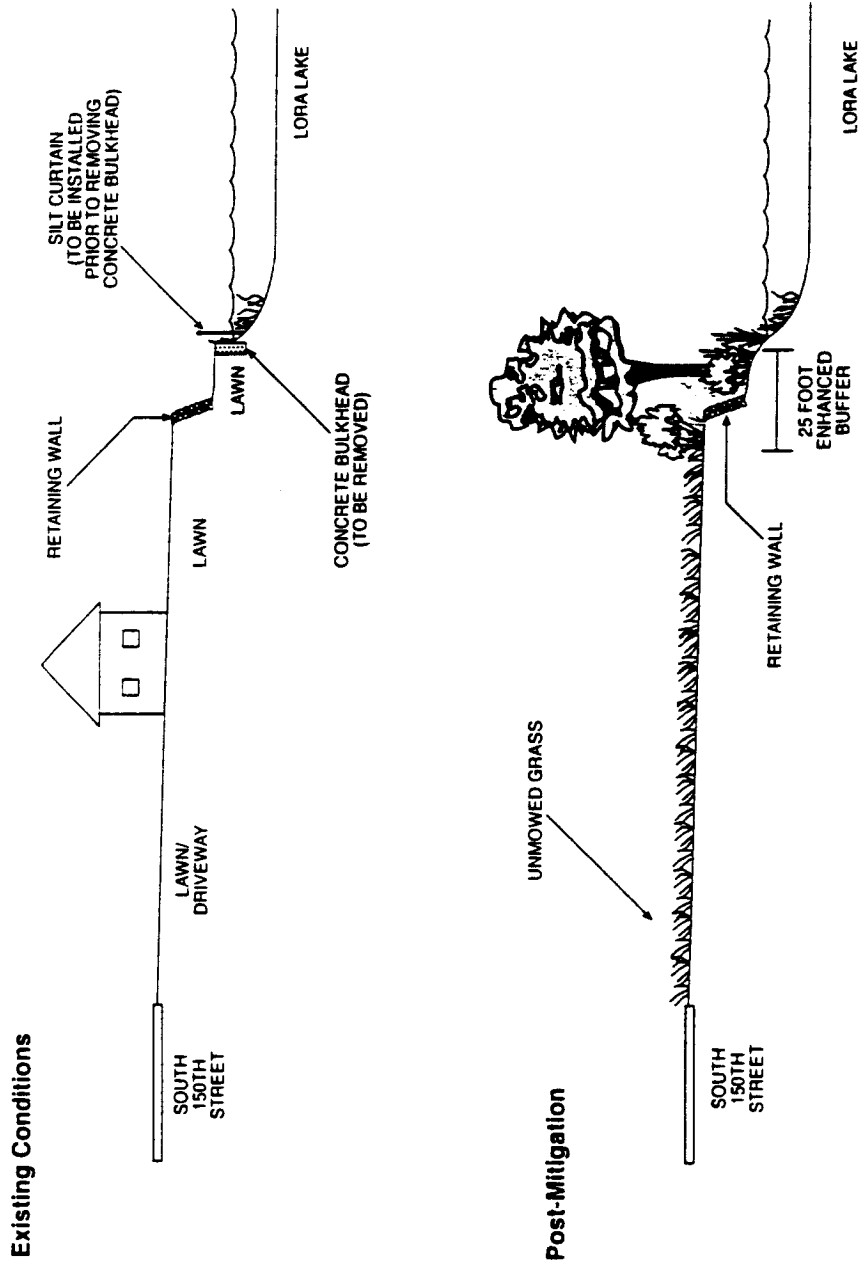
Possible contingency measures that may be implemented to reduce hazard wildlife attractants specific to Vacca Farm are included in Table 5.1-7. Contingencies include eliminating areas of standing water on the floodplain by planting shrubs or minor regrading to eliminate depressions. Measures to control wildlife hazards will be consistent with the Port's WHMP approach described in Chapter 4.

Examples of the types of contingency actions that may need to be implemented at Vacca Farm include:

- If topographic surveys reveal inadequate floodplain storage capacity, additional grading will be undertaken to replace the lost floodplain area.
- If standing water persists on the site for extended periods such that waterfowl use of the site is regular, then corrective actions will be taken to plant densely with shrubs or create positive flow of surface water off the site to Miller Creek.
- If invasive species cover is greater than specified in the performance standards, or if native plant survival is reduced by competition with non-native invasive species, then invasive species removal and/or control will be implemented.
- Replacement plants will be installed if survival is less than 80 percent in the first 3 years.
- If plant species exhibit greater than 20 percent mortality within the first 3 years, site conditions would be re-evaluated to determine whether the conditions could support the species. If the site cannot support the original plant species, then those species may be replaced with species of similar form and function and tolerance to hydrologic conditions on the site.

5.1.3 Lora Lake Shoreline Enhancement

Mitigation at Lora Lake includes removing a concrete bulkhead from the west and north shore of the lake, removing residential structures from the area adjacent to the shoreline, and planting a 25-ft forested buffer around the lake (Figure 5.1-8; Appendix A, Sheet C3.3)(see Table 5.1-1). Replacing concrete bulkheads with a vegetated shoreline, and establishing forested buffers around Lora Lake provide the opportunity to enhance water quality in Lora Lake and Miller Creek. Buffers around the lake will also enhance the functions and viability of the restored wetlands in the Vacca Farm floodplain. Removal of existing residences, lawns, and structures will eliminate future sources of



Port of Seattle/Natural Resource Mitigation Plan/556-2912.001/01(03) 12/00 (K)

**Figure 5.1-8
Typical Cross-Section of Lora Lake
Buffer Enhancement**

VERTICAL SCALE 1" = 40'
HORIZONTAL SCALE 1" = 40'

nutrients and pollutants to the lake and stream. Mitigation at this site also provides an opportunity to reduce existing hazard wildlife attractants near the airport by reducing habitat for waterfowl that graze on the existing lawn around the lake.

5.1.3.1 Goals, Objectives, and Design Criteria

The goal of the buffer enhancement project is to protect and enhance the aquatic habitats in Lora Lake and the upper reaches of Miller Creek by removing shoreline bulkheads and planting native vegetation. Specific design objectives are described in Table 5.1-14.

Table 5.1-14. Mitigation design objectives, and design criteria for the buffer enhancement projects at Lora Lake.

Goals and Design Objectives	Design Criteria
Improve ecological function of the Lora Lake shoreline to the aquatic habitat of the Lake.	<p>Plant a 25-ft buffer (0.60 acre) around Lora Lake with native trees and shrubs.</p> <p>All structures within the 25-ft buffer will be demolished and failing septic systems (if present) will be removed shrubs.</p> <p>Plant native tree species at densities of approximately 280 per acre).</p> <p>Plant native shrub species at densities of approximately 2,100 per acre.</p>
Restore more natural shoreline to Lora Lake by removing concrete bulkhead.	Concrete bulkhead will be removed and shoreline graded to a stable slope configuration.

5.1.3.2 Lora Lake Mitigation Site Description

Lora Lake is a man-made pond excavated from a natural wetland and located in the northern portion of the Miller Creek floodplain. Lora Lake flows into Miller Creek via a 12-inch concrete culvert on the southeast corner of the lake or via flow over the earthen berm that forms the southern shore of the lake.

The area surrounding the lake consists of cement block bulkhead and riprap retaining walls around most of the shoreline on the north and west sides of the lake. Upland areas are located behind the retaining wall and consist of single-family residences, outbuildings, landscaping, mowed lawn, and impervious surfaces such as roads and driveways. Existing septic systems, runoff from roads and rooftops, lawn fertilizers, and pesticides are existing sources of potential pollutants to Lora Lake and Miller Creek. Residential lawns along the lake also attract waterfowl that graze on the turf grasses.

A narrow band of emergent wetland extends around Lora Lake between the cement bulkhead and the riprap retaining wall, and along the south shore of the lake. Just south of Lora Lake is a large deciduous forested wetland (Wetland A1). Detailed descriptions of Lora Lake and Wetland A1 are included in the *Wetland Delineation Report* (Parametrix 2000c).

5.1.3.3 Ownership

The Port owns all of the parcels within the mitigation area surrounding Lora Lake.

5.1.3.4 Rationale for Selection

Enhancing the shoreline and buffers around Lora Lake provides the opportunity to enhance water quality in Lora Lake and Miller Creek, as well as to enhance the function of the restored wetlands in the Vacca Farm floodplain. Removal of existing residences, lawns, and structures will eliminate future sources of nutrients and pollutants to the lake and stream. The overall function of the Vacca Farm projects will be enhanced by providing buffer protection around the lake and the upper reaches of Miller Creek. Mitigation at this site also provides an opportunity to reduce existing hazard wildlife attractants near the airport.

5.1.3.5 Constraints

There are no constraints associated with implementing this mitigation action.

5.1.3.6 Ecological Assessment of the Mitigation Site

Vegetation

Cement block and riprap bulkheads are located around most of the shoreline on the north and west sides of the excavated lake. Most of the area surrounding Lora Lake on the north and west is impervious surface (i.e., turf grass lawn or buildings and roadways). Vegetation is predominantly non-native turf grasses and ornamental landscaping.

A vegetated berm is located along the southern shore of the lake, with a deciduous forested wetland located south of the berm (Wetland A1). An upland shrub area is located to the east. Dominant species on the vegetated berm include red alder, Himalayan blackberry, and various grass species. The forested wetland contains a prevalence of red alder, black cottonwood, willow, Himalayan blackberry, hardhack, and common cattail. The upland shrub area consists of some Douglas fir, with red alder and dense thickets of Himalayan blackberry.

Soils

Soils in the wetland areas surrounding Lora Lake and Miller Creek are composed of organic peat deposits from 3.5 ft to 10 ft thick, interbedded with alluvial sands and silts. Fill material associated with buildings around Lora Lake comprises most of the soils in the upland areas. Soils in the area immediately south of Lora Lake have been amended with sands and organic material imported from off-site to improve the soils for farming.

5.1.3.7 Lora Lake Mitigation Design

To enhance the aquatic functions of Lora Lake, a 25-ft buffer will be established and enhanced around portions of the Lora Lake shoreline, and the concrete bulkhead lining the shoreline will be removed. Figure 5.1-8 shows a typical cross section of Lora Lake before and after restoration.

Demolition and Grading

Residences and various outbuildings, the majority of which are located around Lora Lake, will be demolished prior to implementing this plan. The design includes necessary BMPs to be used throughout demolition activities to prevent sediment from entering the lake or associated wetlands.

Minor grading activities will be associated with establishing the buffers. Prior to planting the buffer areas, grading activities may include roughening the surface, removing portions of lawn, or tilling soil that has been compacted during demolition activities or construction staging. During and following grading, standard TESC measures such as tracking soil surfaces on slopes parallel to the contours, will be implemented to prevent erosion.

Expected Hydrology

It is anticipated that the area located below elevation 265.4 immediately adjacent to Lora Lake will become inundated during 100-year flood events. The groundwater table is high immediately adjacent to the lake shore and this area is expected to be wetland.

Wildlife Considerations

The landscape plan has been designed to be consistent with the WHMP and to avoid attracting flocking birds, raptors, and waterfowl. Dense plantings of shrubs broken by scattered trees will discourage use by flocking birds and waterfowl. To deter raptor use of the mitigation sites, deciduous and coniferous trees with stiff branches (such as Sitka spruce or Douglas fir) will be planted in limited quantities. These species will also break up the deciduous tree canopy. This will limit roosting habitat for raptors such as red-tailed hawks. The primary coniferous tree species used in the upland and transitional zones will be western redcedar because its limp branches do not provide ideal raptor perching habitat.

Landscape Plan

Species to be planted in the Lora Lake buffer are identified in Table 5.1-11. The planting plan for the buffer is shown in Figure 5.1-5 and 5.1-8 and included in Appendix A, Sheets L1 and L2. The Lora Lake buffer includes species such as black cottonwood and willows for the wetter areas immediately adjacent to the lake shore, as well as species such as bigleaf maple and red alder for the drier areas of the buffer.

5.1.3.8 Implementation

Implementation details for Lora Lake are included with the rest of the Vacca Farm projects in Section 5.1.4.

5.1.3.9 Monitoring and Performance Standards

Monitoring for the Lora Lake buffers will follow the overall monitoring approach described in Chapter 4. Detailed performance standards and contingency measures for the Lora Lake buffer are included in Table 5.1-7. Post-construction monitoring will occur for 10 years after installation of the plant material consistent with the schedule in Table 5.1-13.

Monitoring of Lora Lake will focus primarily on vegetation monitoring to evaluate establishment of native vegetation, consistent with the approach described in Chapter 4. The Lora Lake site will also be monitored for hazard wildlife, consistent with the monitoring approaches described in Chapter 4.

5.1.3.10 Site Protection

The Port will execute and file restrictive covenants for the mitigation area. Copies of proposed restrictive covenants are included in Appendix G.

The site perimeter will be protected by fencing approved by ACOE. Site perimeters will also be marked with permanent signs that clearly designate the area as a protected wetland mitigation site. Signs will be inspected regularly and maintained by the Port.

5.1.3.11 Maintenance and Contingency Plans

A maintenance plan will be developed for the Lora Lake buffers, as described in Chapter 4, to guide routine maintenance tasks. Specific contingency measures will be implemented as necessary, consistent with the adaptive management approach. Contingency measures for Lora Lake are listed in Table 5.1-7.

5.1.4 Implementation of the Vacca Farm Mitigation Projects

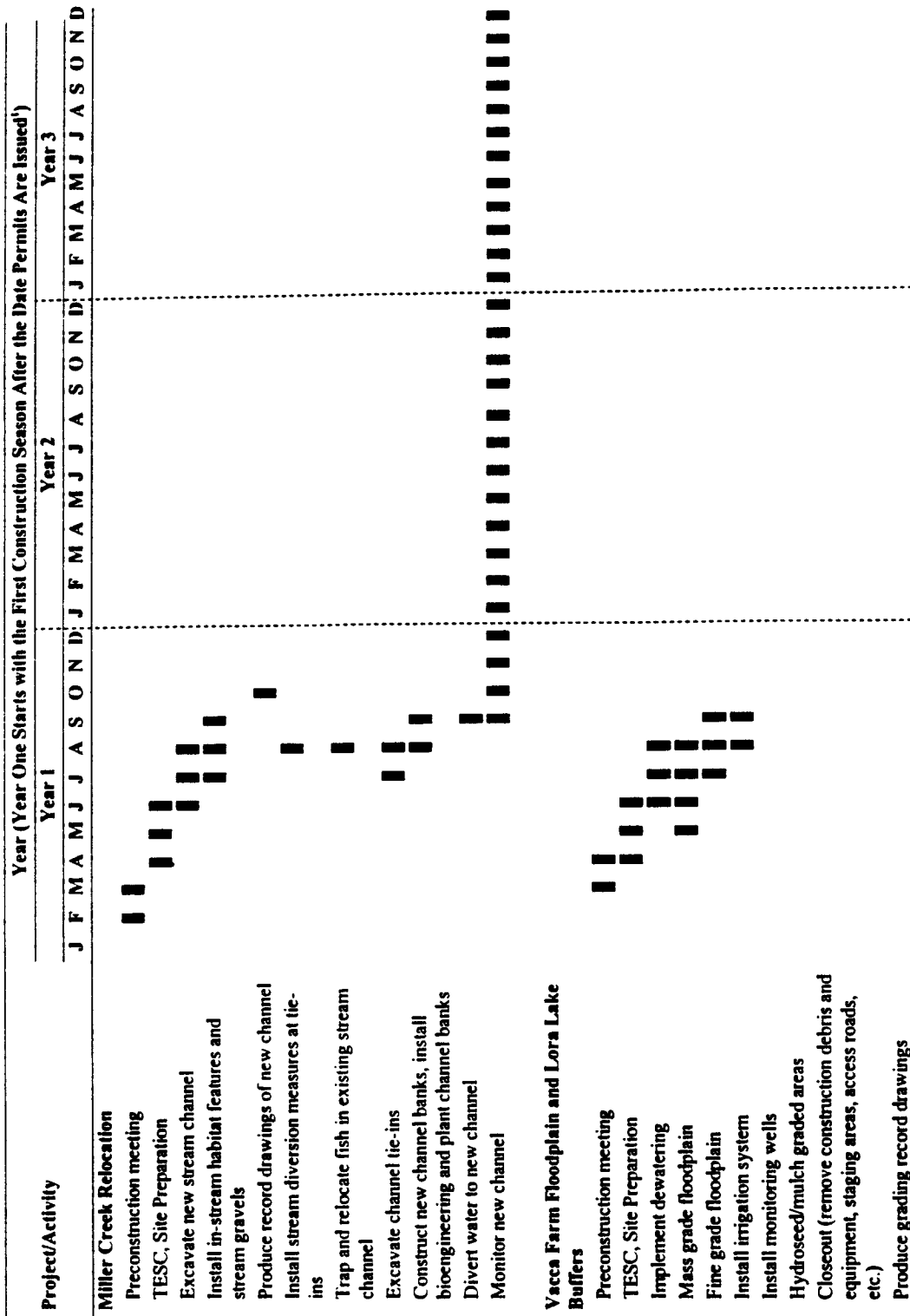
Construction associated with building the proposed third runway, including the relocation of the South 154th Street roadway and sewer line, will be part of the first phase of the proposed MPU implementation. Relocation of Miller Creek must occur prior to embankment construction, which will fill a portion of the existing channel. The new stream channel must be constructed and stabilized before stream flow can be diverted from the existing channel and before the existing channel can be filled. Construction of the Vacca Farm mitigation projects is therefore currently scheduled to begin during the first construction season (i.e., early summer) following issuance of permits for the project. A general schedule for implementation of the Vacca Farm projects is provided in Table 5.1-15. Detailed plan sheets for the Vacca Farm projects are included in Appendix A; design details for the grading and restoration of the banks of Miller Creek at the South 154th/South 156th bridge relocation are included in Appendix B, Sheets P1 through P3.

5.1.4.1 General Construction Sequencing

Construction of the Vacca Farm projects is currently scheduled to begin during the 2001 construction season (see Table 5.1-15), but the actual schedule is dependent on receipt of federal, state, and local permits (e.g., Clean Water Act [CWA] Section 404 and 401). Excavation and grading for the floodplain and stream channel is expected to occur during the driest time of the year, taking approximately 15 weeks, beginning in late June and ending by early October. Instream work associated with the channel relocation will be subject to permit conditions associated with the HPA, and will likely occur between July 15 and September 15.

Construction of the mitigation site will be coordinated with the embankment construction, the South 154th Street relocation (including South 156th bridge relocation), and the relocation of the sewer line to ensure that these projects do not impact the mitigation site. In particular, prior to commencing plant installation, contractors will be required to complete all other work on the site to ensure that plants are not damaged once they are installed.

Table S.1-15. Proposed Implementation Timeline for Vacca Farm Mitigation Projects.



AR 048728

Table 5.1-15. Proposed Implementation Timeline for Vacca Farm Mitigation Projects (continued).

Project/Activity	Year (Year One Starts with the First Construction Season After the Date Permits Are Issued ¹)																																				
	Year 1												Year 2												Year 3												
	J	F	M	A	M	J	J	A	S	O	N	D	J	F	M	A	M	J	J	A	S	O	N	D	J	F	M	A	M	J	J	A	S	O	N	D	
Install plants in Vacca Farm floodplain and buffer, and along Miller Creek riparian zone																																					
Install plants in Lora Lake buffer																																					
Produce planting plan record drawings																																					
Conduct baseline monitoring																																					
Begin maintenance/monitoring period																																					

¹ Plant procurement for all projects will be implemented 6 to 12 months prior to the anticipated planting date to ensure that plants in the specified quantities and species are available by the scheduled planting date. Implementing mitigation projects may vary from this proposed schedule depending upon coordination with other MPU projects and contract obligations.

Construction of Vacca Farm projects will likely take place in several phases. Phase 1 will include most of the earthwork for the Miller Creek channel relocation and floodplain. During Phase 1, the Vacca Farm floodplain will be graded and irrigation installed, the new channel will be excavated, and the channel banks stabilized with bioengineering and planted with live stakes. After the new channel grading is complete, tie-ins will be constructed at either end of the new channel where it connects with the existing channel (Appendix A, Sheets C1.1 and C5). Connecting the new channel to the existing channel will require installing water control devices to divert water to the new channel, and implementing measures to protect fish in the existing channel during construction. The connection of the existing stream channel to the new channel and the diversion of water into the new channel, and stabilizing will occur during the first construction season. Grading of the Miller Creek floodplain adjacent to the new channel will occur concurrently with channel excavation. Removal of Lora Lake bulkheads and grading of the Lora Lake shoreline may also be included in Phase 1 (Appendix A, Sheet C2), although this work is not dependent on the Miller Creek relocation.

Following completion of Phase 1 earthwork, all open areas on the site (i.e., the channel, floodplain areas and Lora Lake buffers) will be hydroseeded and mulched to provide weed barrier and erosion control prior to winter rains and plant installation. Hydroseeding and mulch should be applied by mid-September to ensure that the site is adequately stabilized before the rainy season.

During Phase 2, the old channel will be filled for construction of the runway embankment, and planting floodplain wetlands and buffers during the first fall and/or winter following completion of grading. Completion of buffer planting east of Miller Creek will be coordinated with roadway relocation and will likely not be completed until roadway construction is complete. Phase 2 planting includes the enhancement planting of the existing wetlands, planting the newly graded areas of the floodplain and riparian zone of Miller Creek, and planting new and enhanced buffer areas along Lora Lake, and the east and west sides of the mitigation site (Appendix A, Sheets L1 and L2). Plant installation in these areas may require more than one construction season to complete.

Phase 1: Site Preparation, Grading, and Channel Relocation

Earthwork for this phase includes site preparation, installation of sediment and erosion control measures, dewatering if necessary, grading, installation of irrigation, and site stabilization following grading.

Site Preparation and Erosion Control

No work will begin until the TESC plan is implemented (Appendix A, Sheets TE1 and TE2), nor until any protected or restricted access areas (e.g., wetlands or streams) have been flagged and/or fenced. The TESC plan includes installation of silt fences around the existing wetlands to be enhanced southeast of Lora Lake, and the Lora Lake shoreline, to prevent sediment from the construction site entering these waters (Appendix A, Sheet TE1). A temporary berm will be constructed and a silt fence installed to protect adjacent properties to the south of the mitigation site and prevent water from the construction site from entering the drainage ditch that runs through the center of Wetland A1.

Water from the construction site will likely be directed to the temporary sediment settling pond at the lowest (i.e., southern) end of the proposed floodplain (Appendix A, Sheet TE1). Water from this pond will be allowed to settle until particulates and sediment have settled out. Water from the site can then be discharged via the outlet, quarry spalls, and straw bale filters to Miller Creek (Appendix A, Sheet TE2). Alternatively, construction stormwater runoff may be diverted or pumped to TESC Pond C. Water in the sediment ponds and discharge will be monitored to ensure that turbid water is not discharged to the stream.

Additional TESC measures include placing silt fence around work areas and staging areas, and placing straw bales at key locations within the project limits. Clearing and brush removal will be limited to only those work areas that the contractor is scheduled to begin within the following 2 weeks.

Prior to the start of grading, construction access, staging, and stockpile areas will be set up, and dewatering may be necessary. Temporary access routes and staging areas identified on the western side of the site will be set up and flagged (Appendix A, Sheets C2, TE1). The site will be cleared of debris (e.g., existing tile drains, storm drains and piping, trash, structures).

Construction sequencing of the mitigation site and the roadway/embankment will be carefully coordinated to prevent impacts to the completed mitigation site from roadway construction. Measures to protect the mitigation site from adjacent construction may include orange barrier fencing, sediment and erosion control fencing, and possibly the temporary installation of ecology blocks or rock gabions to prevent the intrusion of construction machinery into the mitigation site.

Dewatering

Due to the high groundwater table throughout the Vacca Farm site, excavation of the floodplain and new channel will likely require dewatering. The dewatering pumps, temporary storage ponds, and sediment and erosion control measures will be installed prior to the start of new channel excavation or floodplain grading. The dewatering system may include excavating dewatering trenches and installing French drains or sumps. The exact location of dewatering trenches and temporary storage ponds will be determined by the contractor. The location of these dewatering features may change as the excavation and final grading of the floodplain proceeds; however, all dewatering wells, temporary storage ponds, and/or trenches will be within the area to be excavated for the floodplain grading (Appendix A, Sheets C2, TE2). In addition, all water from dewatering areas will be directed to sediment settling ponds and any sediment will be allowed to settle prior to being discharged via a quarry spall outfall and straw bale filters to Miller Creek (see Appendix A, Sheet TE2). All dewatering features will either be removed as a consequence of the ongoing excavation (e.g., trenches, drains) or removed and the area graded once they are no longer needed (e.g., temporary storage ponds).

New Channel Excavation and Floodplain Grading

New channel construction includes excavation of the new channel, stabilization of channel banks, installation of stream gravels and woody debris, implementation of fish protection measures, construction of the tie-ins to the existing channel, diversion of water to the new channel, and filling in the old channel. Construction in the existing channel will likely take place between July 15 and September 15, consistent with conditions in the HPA.

The new channel will be excavated and water diverted from the existing channel within the same construction season. The new channel banks are expected to be adequately stabilized to carry dry and wet season flows for the following reasons. The new channel banks will be stabilized using bioengineering (e.g., coir lifts with live stakes, erosion control fabric) (Appendix A, Sheets C5 and L2). Channel banks will be planted densely with willow stakes to provide additional stabilization and channel roughness. The dry and wet season base flows in this portion of Miller Creek are typically low (< 5 cfs) and the new channel slope is very gradual. Therefore, even during storm events, flows in Miller Creek through this reach will not have large amounts of energy. Furthermore, the channel has been designed with a low flow channel inside a wider channel meander zone, which can accommodate up to annual peak flows (Appendix A, Sheet C5). Flows greater than annual peak flows will flood onto the floodplain, rapidly attenuating the energy and erosive force of stormflows.

The sequence of steps required to divert existing flows to the new channel will be consistent with HPA permit conditions and will be conducted to reduce stress and impacts on aquatic organisms. Prior to constructing tie-ins and diverting Miller Creek to the new channel, the section of the existing channel to be diverted will be closed off, and fish within the existing channel will be captured and relocated to a point downstream of South 160th Street where suitable habitat exists. Fish capture and relocation will be done under the supervision of a qualified fish biologist with a collection permit from the WDFW.

Immediately following fish capture, the tie-ins will be constructed, and flow from the existing channel will be intermittently introduced to the new channel section to allow the streambed gravels to sort and stabilize. Flows will be intermittently introduced to the new channel with a gate valve or other control structure to allow flows to be metered. During this time a collection sump located at the downstream end of the new channel will collect water. Turbid water will be conveyed to a sediment pond until the new channel flows clear. After diversion of stream flow has been successfully completed, the existing channel will be filled during embankment construction.

Excavation of the floodplain grades at Vacca Farm may occur concurrently with the new channel excavation. Floodplain grading will begin as soon as the contractor can control the groundwater sufficiently for excavation. Grading will occur on all areas of the mitigation site with the exception of the existing wetland to the east of Lora Lake (i.e., between Lora Lake and Miller Creek) and the area of upland buffer along the western portion of the site (Appendix A, Sheets C1.1 and L1). Existing drainage ditches on the site will be filled and removed during grading to restore site hydrology. A swale will be constructed through the floodplain to allow the floodplain to drain gradually to the south (Appendix A, Sheet C2) and to prevent standing water on the floodplain (Appendix A, Sheet C2). Cross sections are provided in the plan sheets that show the proposed site elevations following grading (Appendix A, Sheets C1.2 and C4). In addition to floodplain grading, existing bulkheads along the north and west shoreline of Lora Lake will be removed and a more gradual slope will be restored to the lake shoreline. Removal of the bulkheads prior to planting buffer vegetation will enhance the function of the buffer to be planted along Lora Lake.

Installation of Temporary Irrigation and Site Stabilization

Once the new floodplain grades have been established and verified by field survey, the temporary irrigation system will be installed. A temporary irrigation system will be used to provide flexibility

in the planting schedule, to provide contingencies against seasons of extreme drought during the first few growing seasons, and to maximize plant survival and growth during the initial years of the mitigation. Allowing for maximum plant growth during the first years of the restoration will result in more rapid establishment of cover and shade on the site, as well as more rapid production of biomass, vertical habitat structure, and organic litter. The use of irrigation is a standard feature of wetland mitigation construction in the Puget Sound Lowlands due to the region's pronounced summer drought. Irrigation will be designed for the entire area to be graded at Vacca Farm; however, irrigation may not be necessary in some areas. If, following grading, the wetland scientist determines that irrigation is not needed in some areas, it will not be installed. Irrigation will be accomplished using city water. The irrigation system will be decommissioned and all above-ground parts removed at the direction of the wetland scientist following two to three growing seasons.

The site will be stabilized following completion of grading and prior to the onset of winter rains. A hydroseed/mulch mix designed to provide temporary erosion control and a weed barrier will be applied to the graded floodplain areas by mid-September.

Phase 2: Establish Native Vegetation in the Miller Creek Channel, Floodplain, and Buffer

Planting plans submitted in the Mitigation Plan have been refined based on the ongoing design, comments received on the Public Notice, and agency consultation (Appendix A, Sheets L1 and L2). The channel area will be planted as soon as channel excavation is complete. In areas with irrigation, planting will not be limited to fall or winter planting seasons, but in areas lacking irrigation, planting will occur only during the fall and/or winter months. Planting of the stream buffer and adjacent floodplain can occur as soon as site grading and irrigation installation are complete and hydroseed has become established.

It is anticipated that floodplain and buffers, stream riparian zone and buffers, and Lora Lake buffer planting will begin the first fall (i.e., October or November) following completion of grading and irrigation installation. Planting of the entire site will likely require more than 1 year to complete. Immediately following plant installation, the area between plants will be mulched or covered with a weed control fabric to reduce establishment of weeds. Plant collars or other herbivore deterrents may be installed to reduce damage from rodents and other herbivores.

Soils on the Vacca Farm site are a mix of interbedded peats, sands, silts, and gravels below the plowed layer. Following excavation and grading, the material exposed at the surface will likely vary from predominantly peat to a mix of sands, gravels, and silts. To ensure a medium suitable for plant establishment, 12 to 14 inches of prepared topsoil will be spread over the surface following grading. Where feasible, the prepared topsoil will be comprised of native materials from the site, mixed to obtain a topsoil with a 3:1 mineral to organic material mix. Where not feasible, prepared topsoil will be a 3:1 mix of clean sand with organic compost that is free of weed seed or other unsuitable material.

Plant material used in the mitigation will be obtained from commercial nurseries. Nurseries will be required to certify that the plant material is legally procured and from the appropriate geographic sources. The appropriate geographic sources for plant material used in the mitigation is the area that is bounded on the north by the Fraser River Valley of British Columbia, on the east by the 1,000-

foot elevation of the Cascades, on the west by the 1,000-foot elevation in the Olympic or Coast ranges, and on the south by the Willamette Valley.

5.1.4.2 Construction Steps

The following sections provide a general outline of the construction and post-construction steps necessary to implement the Mitigation Plan for the Vacca Farm area.

General Conditions

- On award of the contract, the contractor will provide the Port with any required pre-construction submittals, work plans, and schedules.
- A pre-construction meeting will be held with the contractor, architect/engineer, and wetland scientist to review submittals, work plans, schedules, and permit conditions.
- The contractor will be responsible for ensuring that the work is performed in compliance with all permit conditions and shall maintain a copy of permits on-site.
- Work will be coordinated to avoid re-entry and damage to areas that have previously been planted; work will be conducted so that no other work will impact completed landscape work.
- Areas where any landscape work has been completed will be off limits to all vehicular traffic, and pedestrian traffic will be strictly limited.
- All site work will be performed in accordance with permit conditions; any instream work or work below Ordinary High Water (OHW) will take place only during the allowable work times, consistent with HPA permit conditions (i.e., July 15 to September 15).
- Plant procurement shall be coordinated with the grading and irrigation installation schedules and be done 6 to 12 months prior to the scheduled planting season to ensure that plants are available in the quantities and species required by the planting plan.

Site Preparation

- Establish vertical and horizontal site controls and maintain through construction to record drawings.
- Identify and flag limits of work for mitigation site.
- Identify staging areas and temporary access/haul roads.
- Implement TESC plan, install TESC measures for all projects, including the Miller Creek channel relocation, floodplain grading, Lora Lake buffer planting, and Miller Creek buffer enhancement areas.
- Identify and flag sewer manholes and sewer easement.
- Install fencing (orange barrier) around areas to be protected (e.g., existing wetlands, outlet ditches, sewer manholes).
- Maintain security of the site through construction.

- Establish temporary access/haul roads.
- Establish staging and stockpile areas.
- Implement a spill control plan and identify fueling areas.
- Install site dewatering equipment and structures (e.g., pumping wells, manifold piping, temporary storage ponds, discharge structure).

Clearing, Excavation, and Grading

- Clear and grub the site.
- Implement dewatering for new channel construction, if necessary.
- Fill in or remove drainage ditches.
- Excavate new channel subgrades (except at tie-in areas).
- Confirm new channel subgrades with field survey.
- Install log weirs and quarry spalls.
- Place streambed material and grade low-flow channel.
- Confirm new channel finish grades.
- Construct new channel banks; install coir fabric-wrapped streambank material.
- Install coir logs and coir mattresses.
- Install instream habitat features in new channel.
- Install channel plantings and bioengineering.
- Remove weeds (e.g., grub out blackberry and reed canarygrass; apply herbicide if appropriate per specifications) and clear brush in wetland buffer enhancement areas.
- Mass and fine grade floodplain.
- Install microtopography/large woody debris on floodplain.

Construct New Channel Tie-Ins to Existing Channel

- Implement fish-protection and erosion control measures for tie-in construction.
- Install sheeting and base flow stream diversion sumps at tie-in areas.
- Excavate new channel grades at tie-in areas.
- Install transition area log weirs and quarry spalls at tie-in areas.
- Place streambed (spawning) gravel and grade low-flow channel at tie-in areas.
- Confirm new channel finish grades.
- Construct new channel banks.
- Install coir logs and coir mattresses at tie-in areas.
- Install bioengineering.

- Divert water into new channel.
- Place fill in existing channel at tie-in areas.
- Prepare grading record drawings for new channel and floodplain; modify planting plans as needed to match as-built grades and site conditions

Irrigation and Landscaping

- Install and test irrigation system in floodplain.
- Apply hydroseed to graded portion of the floodplain.
- Winterize irrigation system.
- Begin planting in fall/winter following grading.
- Plant riparian/buffer zone of new channel.
- Plant Miller Creek floodplain and other wetland enhancement areas.
- Plant upland buffer adjacent to floodplain and Lora Lake buffers.
- Place sterile organic mulch (e.g., wood fiber) 4 to 6 inches deep between planted stock as a weed barrier.

Closeout

- Complete site cleanup by removing temporary haul/access roads, TESC berm, and staging areas.
- Remove construction equipment and debris.
- Hydroseed and/or install plants in temporary staging areas or access roads within the mitigation site boundaries.
- Hydroseed erosion control mix in temporary staging areas/access roads outside the mitigation boundaries.

Record Drawings, Monitoring, and Maintenance

- Produce record drawings (including grading, instream habitat, and planting) for all project areas (e.g., Lora Lake buffers and shoreline, Miller Creek floodplain, relocated channel, and Miller Creek buffer between new channel and South 154th Street/South 156th Street Bridge).
- Complete a baseline report, including record drawings and final monitoring plan (e.g., locations of monitoring plots, baseline conditions).
- Begin compliance monitoring during the first growing season after all grading and planting are complete; submit annual monitoring reports for 10-year monitoring period.
- Conduct maintenance (e.g., weed management, WHMP) and implement any necessary contingency measures to meet performance standards.

5.2 MILLER CREEK RIPARIAN AND INSTREAM ENHANCEMENT PROJECTS

Mitigation along Miller Creek from the Vacca Farm site to Des Moines Memorial Drive is designed to establish a large, contiguous habitat corridor extending approximately 6,500 ft along the stream, connecting habitats that are currently fragmented by urban land uses. Within this corridor, instream, wetland, and non-wetland riparian habitats will be restored and enhanced. Instream habitat in Miller Creek will be restored by removing channel armoring, restoring more natural channel morphology, and installing habitat features. Riparian wetlands along Miller Creek will be enhanced by removing structures and impervious surfaces, removing non-native vegetation, and planting with native wetland vegetation. Non-wetland riparian buffers along Miller Creek will be enhanced to stabilize soil; retain sediments and nutrients; and provide shade, organic matter and woody debris to the stream.

Mitigation measures along Miller Creek will also be implemented to compensate for filling existing drainage channels, to maintain the hydrology of wetlands between Miller Creek and the new runway embankment, and to mitigate for temporary construction impacts to wetlands. These mitigation actions are designed to prevent indirect hydrologic impacts to wetlands downslope of the embankment. Replacement drainage channels will be constructed to maintain inputs from surface water runoff and groundwater seepage to wetlands downslope of the new embankment, and wetlands temporarily impacted by construction will be restored to pre-construction conditions.

To compensate for unavoidable project impacts to wetlands and streams, the Miller Creek buffer and instream enhancement projects include the following specific mitigation actions:

- Restoring and enhancing functions in approximately 7.4 acres of riparian wetlands along both sides of a 6,500-ft reach of Miller Creek between the Vacca Farm site and Des Moines Memorial Drive.
- Restoring and enhancing a native, forested riparian buffer corridor along the east and west sides of this 6,500-ft section of Miller Creek, to protect and improve aquatic habitat in the stream, associated drainage channels, and riparian wetlands.
- Establishing a large, contiguous, protected riparian habitat corridor connecting the upper and lower reaches of Miller Creek.
- Restoring fish and aquatic habitat to degraded, highly modified reaches of Miller Creek by adding LWD and boulders, reconstructing natural stream channels, removing man-made obstructions, and reshaping or stabilizing streambanks (Section 5.2.2).
- Replacing approximately 1,290 linear ft of drainage channels near 12th Avenue to compensate for existing drainage channels that will be filled by the third runway embankment (Section 5.2.3).
- Restoring approximately 2.05 acres of riparian wetland that will be temporarily impacted by construction of the runway embankment (Section 5.2.4).
- Encouraging and promoting additional local stream restoration efforts in the basin; the Port will create a \$150,000 trust fund to be used for stream restoration projects in the Miller Creek basin (Section 5.2.5).

5.2.1 Miller Creek Riparian Corridor Wetland and Buffer Enhancement Plan

The physical and biological functions provided by riparian vegetation will be enhanced along approximately 6,500 ft of Miller Creek. Protection and enhancement of the buffer will enhance the physical functions forested buffers provide, including reducing stream water temperatures, reducing erosion and suspended sediment releases to streams, influencing channel morphology by contributing large woody debris to the channel, and stabilizing the banks. Riparian restoration will also enhance biological functions of stream buffers, such as increasing nutrient cycling and retention, increasing organic carbon export to the stream, and providing habitat and food resources to aquatic organisms.

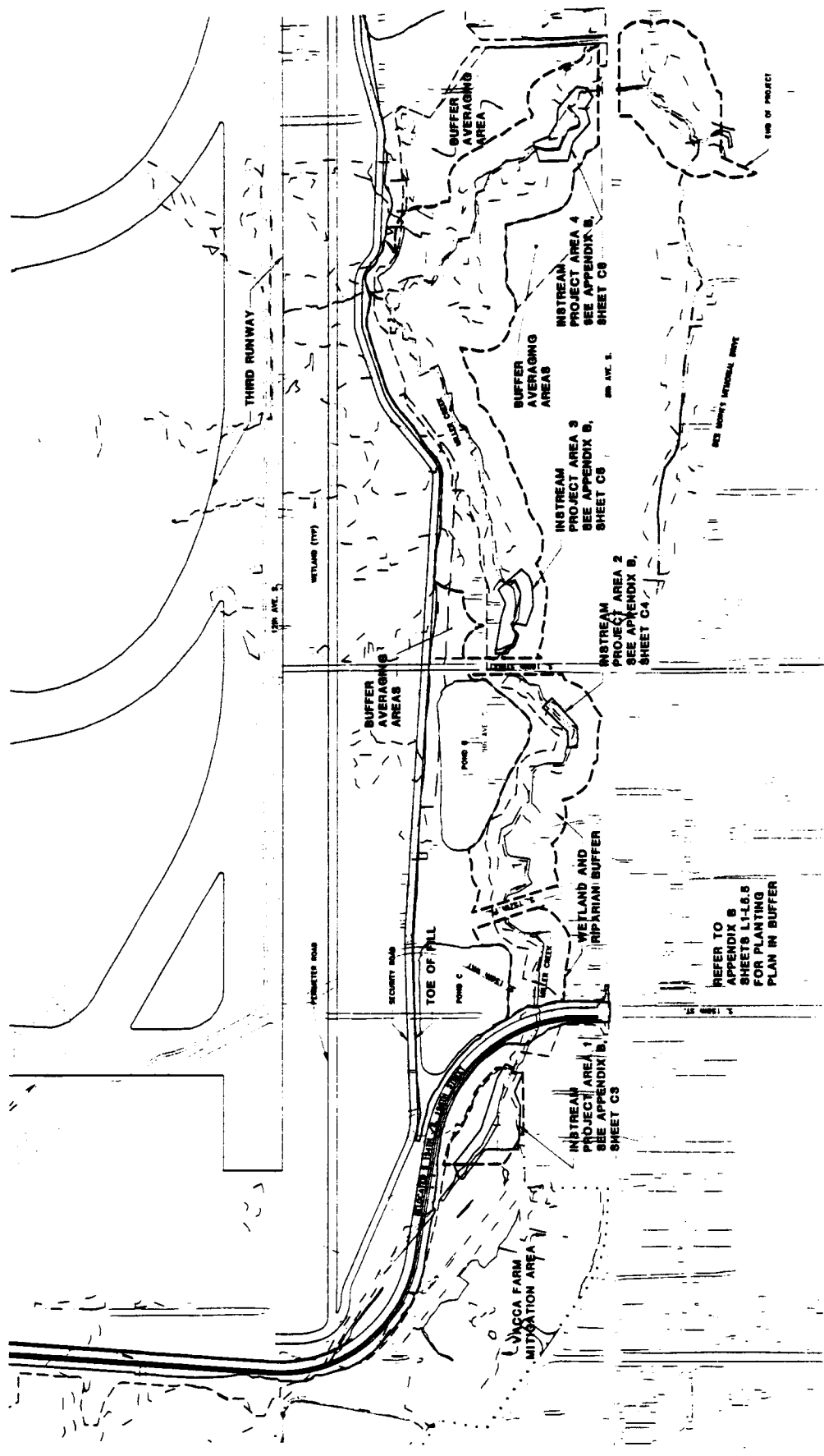
As a consequence of past development in the Miller Creek watershed, buffers have been removed or degraded along much of the stream. Native forested vegetation has been replaced by impervious surfaces, ornamental turf grasses, or landscaping. These alterations reduce the ability of the existing buffer to support the biological and physical functions necessary to maintain quality habitat in adjacent streams.

To restore functions to aquatic resources, riparian wetlands, and buffer along Miller Creek, a buffer area that averages 100 ft wide on both banks of the stream (approximately 40 acres) will be enhanced (Figure 5.2-1; Appendix B). Approximately 7.4 acres of riparian wetland habitat and approximately 32 acres of buffer will be enhanced. Buffer and wetland enhancement activities along Miller Creek include removal of all residential structures and associated impervious surfaces, underground oil storage tanks, and septic systems. Non-native, invasive species will be removed from wetlands and riparian areas where they would prevent the establishment of native vegetation, and where removal will not destabilize stream banks or result in increased sedimentation. These specific areas are shown as shaded zones in Appendix B, Sheets L1 through L5. The wetlands and riparian buffer will be enhanced by planting areas of existing lawn, predominantly non-native vegetation, or disturbed areas (i.e., from which structures or impervious surfaces have been removed) with native, predominantly forested vegetation (Figure 5.2-2 and in Appendix B, Sheet L1 through L5.1). Wetland or riparian buffer areas which currently have predominantly native forested or shrub vegetation will be enhanced with in-fill planting of native trees or shrubs.

Design of the Miller Creek wetland and riparian buffer enhancements has been coordinated with the design and location of stormwater detention ponds, the South 156th Way bridge replacement, location of airport security roads and utility easements, as well as with design of replacement drainage channels (see Section 5.2.3). Appropriate BMPs will be implemented and construction activities sequenced to ensure that there are no impacts to buffer enhancement projects from other mitigation or MPU construction activities (see Implementation, Section 5.2.2.10 for details).

5.2.1.1 Goals, Objectives, and Design Criteria

The primary goals of the buffer enhancement plan are to enhance functions in riparian wetlands and in aquatic habitat within and downstream of the Miller Creek riparian corridor by restoring a forested buffer along the entire length of Miller Creek in the acquisition area Table 5.2-1).



**Figure 5.2-1
Miller Creek Instream and
Buffer Enhancement**

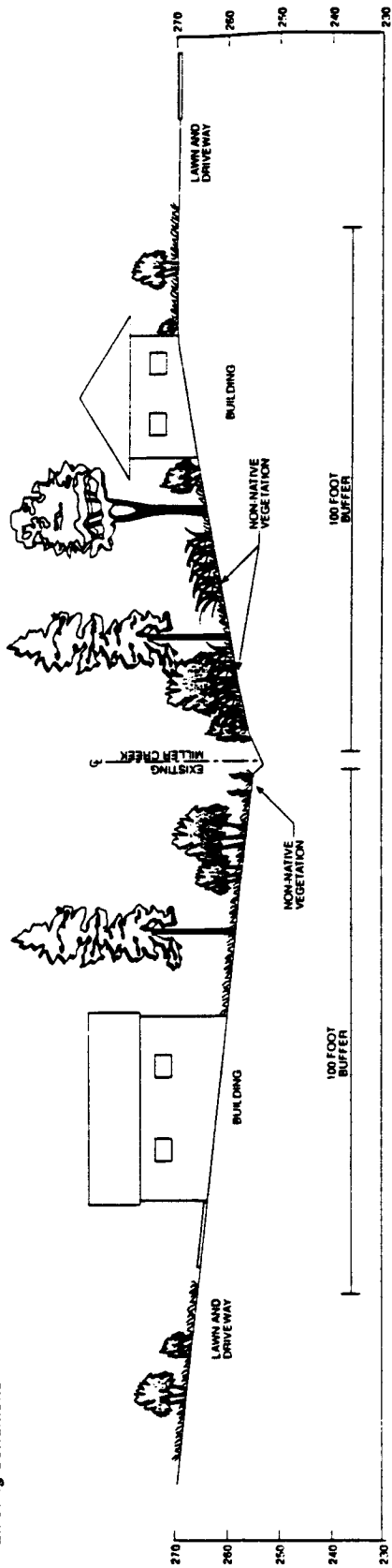
- NOTES:
1. ACCESS TO PROJECT SITES BY APPROVAL OF ENGINEER
 2. WETLAND AREAS NOT TO BE DISTURBED BY EQUIPMENT. WETLAND AREAS WILL BE STAKED AND MARKED IN THE FIELD BY THE ENGINEER OR SURVEYOR.

- LEGEND
- MILLER CREEK
 - WETLANDS
 - BUFFER AVERAGING AREA
 - INSTREAM PROJECT AREA
 - VACCA FARM MITIGATION AREA
 - WETLAND AND RIPARIAN BUFFER

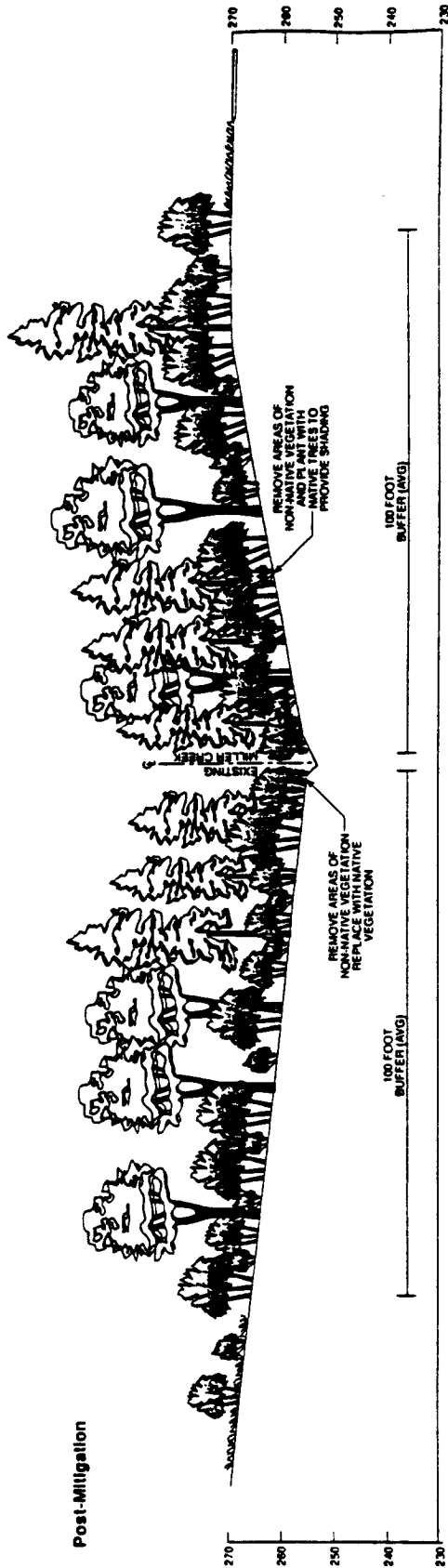


SCALE IN FEET
0 175 350

Existing Conditions



Post-Mitigation



Part of Seattle/Natural Resource Mitigation Plan/556-2912-001/01(03) 12/00 (K)

**Figure 5.2-2
Typical Cross Section of Miller Creek
Stream Buffer Enhancement**

VERTICAL SCALE 1" = 30'
HORIZONTAL SCALE 1" = 30'

Table 5.2-1. Mitigation goals, design objectives, and design criteria for the Miller Creek wetland and buffer enhancement project.

Goals and Design Objectives	Design Criteria
Goal: Enhance aquatic habitat in the Miller Creek by establishing a forested buffer.	
Restore approximately 40 acres of riparian buffer along Miller Creek.	Demolish existing structures, remove maintained lawn, landscaping, and portions of non-native vegetation located within 100 ft of Miller Creek (or its adjacent wetlands), and buffer averaging areas (40-acres total). Remove potential water quality impacts such as failed septic systems and untreated stormwater runoff from the buffer area.
Enhance wetland and riparian.	Riparian buffer areas that are cleared or disturbed during demolition will be planted with native forested and shrub vegetation. Plant native tree species at densities of greater than 280 per acre. Plant native shrub species at densities of greater than 2,100 per acre. Lawn areas and other areas dominated by non-native species, will be enhanced by planting native forested vegetation.
Increase shade and detritus input to the aquatic environment.	Densely plant the portion of the buffer adjacent to the stream with native trees and shrubs where applicable to provide overhanging vegetation to provide future sources of LWD to the stream.
Reduce erosion and sedimentation to Miller Creek.	Remove existing structures, such as riprap walls and bridges, to reduce channel scouring. Increase sediment retention in the buffer by planting trees and shrubs.
Provide long term protection to the Miller Creek Buffer.	Establish restrictive covenants to permanently protect buffer. Install fencing and signs to designate area as protected mitigation site.

5.2.1.2 Mitigation Site Description

The section of Miller Creek included in the riparian enhancement projects is located along both sides of Miller Creek between the southern portion of the Vacca Farm site and where the stream flows under Des Moines Memorial Drive (Appendix B, Sheet C2).

The Miller Creek buffer was established by adding a 100 ft buffer from the OHWM of Miller Creek or from the edge of riparian wetlands (riparian wetlands are those that are directly associated with Miller Creek). Approximately 4.8 acres of permanent detention ponds, relocated South 154th/South 156th Street, and the third runway embankment encroached into this buffer. Additionally, an existing sanitary sewer line and a 20-ft easement, totaling approximately 1.7 acres, was calculated as an encroachment. Buffer averaging was applied at three locations along the stream to compensate for these encroachments. The buffer and buffer averaging areas total approximately 40 acres (Appendix F).

The riparian buffer vegetation consists primarily of turf grass lawns, areas of ornamental non-native landscaping, or non-native invasive plant species such as Himalayan blackberry, English ivy (*Hedera helix*), and Japanese knotweed (see Figure 5.2-2). Existing land uses in the buffer area include residential structures (such as houses and outbuildings), roads, small stock farms, and horse pastures. In small patches along the channel and in several wetland areas adjacent to the stream, native tree and shrub species occur such as red alder, black cottonwood, Pacific (*Salix lasiandra*) and Sitka willow (*Salix sitchensis*), hardhack, lady fern (*Athyrium felix-femina*), horsetail (*Equisetum* sp.), and various native and non-native grasses.

Twenty-one wetlands are present within the proposed Miller Creek wetland, Riparian buffer and buffer averaging areas (see Table 3.1-4). These wetlands are 18, 37a, A1, A9, A10, A11, A13, A16, R1, R2, R3, R4, R4b, R5, R5b, R6, R6b, R7, R7a, R8, R9, R9a, R10, R11, R12, R13, R14a, R14b, R15a, R15b, and R17. A complete description of these wetlands is provided in the *Wetland Delineation Report Master Plan Update Improvements Seattle-Tacoma International Airport* (Parametrix 2000c).

5.2.1.3 Ownership

All parcels within the riparian wetland and buffer enhancement area shown in Figure 5.2-1 are owned by the Port.

5.2.1.4 Rationale for Selection

Restoring the riparian habitat along this reach of Miller Creek provides on-site and in-kind mitigation opportunities to replace wetland and stream functions impacted by the project. Despite past degradation, the downstream reaches of Miller Creek contain habitat for salmonids. Acquisition, permanent protection, and restoration of a significant portion of Miller Creek has the potential to significantly enhance wetland and aquatic habitats in the Miller Creek basin, including downstream segments not within the project area. Removing residential land uses and associated non-point source pollution and physical impacts, such as clearing and dumping, will enhance the wetland and riparian plant communities, as well as water quality and aquatic habitat within the stream.

The planned restoration and enhancement of the Miller Creek riparian corridor provides an exceptional opportunity to remove anthropogenic impacts, and to establish a large contiguous riparian habitat corridor within a highly urbanized watershed. Few such opportunities exist to perform habitat restoration at this scale on significant salmonid-bearing streams in urban environments.

5.2.1.5 Constraints

There are no constraints to implementing the mitigation as proposed. Specific mitigation actions have been limited in portions of the mitigation area affected by steep slopes or existing native vegetation. For example, in areas that cannot be accessed without causing increased erosion, or disturbance to desirable vegetation, enhancement actions are not planned.

5.2.1.6 Ecological Assessment of the Mitigation Site

Ecological conditions relevant to the mitigation design and implementation are discussed in this section.

Hydrology

The majority of the proposed buffer zone contains uplands and areas of riparian wetlands. Seasonal soil saturation can occur in some of the upland areas near the stream. Inundation of some riparian wetlands occurs during the high flow periods that may occur in late fall, winter, and spring. Soils in most of the riparian wetlands remain moist during the summer months, and portions of some wetlands (e.g., Wetland 18 and 37) remain perennially saturated. Non-riparian wetlands in the buffer area are typically saturated during the late fall through early summer period.

Evaluations of project impacts to wetlands (Parametrix 2000b) demonstrate that, with the proposed mitigation, groundwater will continue to be available to support wetlands protected by the Miller Creek buffer. Mitigation to further protect and monitor these wetlands is discussed in Section 5.2.3.

Soils

The project area has not been mapped by the Soil Survey of King County Area Washington (Snyder et al. 1973). However, various soil test pits were dug during field investigations for wetland delineations within the Miller Creek area. Alluvial soils with high organic matter were found in the small riparian wetlands. Soils throughout the remainder of the Miller Creek riparian corridor, south of the Vacca Farm site, are disturbed due to residential development, but appear to be typical Alderwood soils (Snyder et al. 1973). Alderwood series are primarily made up of moderately well-drained soils forming on glacial till. In some areas, soils were predominantly a sandy loam, with a soil profile that corresponds to Indianola soils (Snyder et al. 1973).

Vegetation

South of the Vacca Farm site, between South 156th Street and South 160th Street, the riparian vegetation is a complex mix of types. Areas of residential landscaping, such as lawns and ornamental plantings, and areas of non-native invasive vegetation, are intermixed with areas of native upland and wetland vegetation. Non-native dominant plants include such invasive species as Himalayan blackberry, Japanese knotweed (*Polygonum cuspidatum*), and English ivy.

Riparian vegetation south of South 160th Street is more often dominated by native plant species than the area between Vacca Farm and South 160th Street. Common species identified in the canopy layer include red alder, western redcedar (*Thuja plicata*), English holly (*Ilex aquifolium*), and some Douglas fir (*Pseudotsuga menziesii*). Dominant species in the shrub layer consist of Himalayan blackberry, salmonberry (*Rubus spectabilis*), willow, and Indian plum (*Oemleria cerasiformis*), with horsetail species, lady fern, swordfern (*Polystichum munitum*), and various upland and wetland grasses in the herbaceous layer.

To assess the extent of non-native vegetation located within 100 ft of the stream, a vegetation survey was conducted along each parcel that borders Miller Creek. Detailed descriptions of the vegetation in each parcel within the riparian buffer are provided in Appendix B, Sheets L1 through L6.

5.2.1.7 Miller Creek Wetland and Riparian Buffer Enhancement Mitigation Design

Conditions along Miller Creek vary widely in terms of existing vegetation, presence of structures, and percent cover of non-native invasive species. Due to this variation, a single mitigation design is not appropriate for the entire buffer area. Given the range of existing conditions, four different buffer-enhancement actions will be implemented, depending on site-specific conditions (Table 5.2-2 and Appendix B, Sheets L1 through L5). Specific performance standards for the buffer enhancement area are provided in Table 5.2-3. Depending on existing conditions in a given part of the buffer, mitigation actions may include one of the following:

- Removing structures and/or existing non-native invasive vegetation, and re-planting with native vegetation (i.e., clearing and re-planting).
- Controlling and managing patches of non-native invasive vegetation, and re-planting with native vegetation (i.e., invasive management and re-planting).
- Retaining the existing native vegetation matrix but infill planting to increase species diversity and habitat structure (i.e., infill planting).
- Retaining and protecting existing native vegetation with the designated buffer (i.e., protection).

Removal of Structures and Impervious Surfaces

All structures, underground storage tanks and septic systems, roads, and driveways within the proposed buffer along the Miller Creek riparian corridor will be demolished and removed. If abandoned underground pipes or other structures do not pose risks to water quality, they may be left plugged and in place.

Demolition will be designed to minimize disturbance to existing native vegetation and soils. The contractor responsible for demolition of structures within the stream buffer areas will follow BMPs to prevent erosion and sedimentation to the stream. The Port has already demolished many residential structures within the stream buffer using sediment and erosion control BMPs to prevent erosion and sedimentation to the stream or wetlands. Standard practice prior to any demolition activity is to install an orange barrier fence and a sediment fence between the demolition site and any wetland or water feature. These standard BMPs will continue to be used throughout the demolition activities associated with the Miller Creek buffer enhancement plan. Materials removed from the buffer area during demolition will be disposed of off-site at an approved upland disposal facility.

Grading and/or Clearing

Grading activities will include removing existing structures, fill material, and driveways in the designated buffer areas. Additional minor grading will remove landscape features such as retaining walls. Clearing of large patches of non-native invasive species from accessible areas along the stream is proposed. On parcels where large areas of blackberry or other invasive species will be removed (such as Parcels 255, 256, and 260), the top 6 to 12 inches of topsoil may be tilled and removed if necessary to remove the root stocks of invasive species.

Table 5.2-2. Enhancement planting approach along the Miller Creek buffer.

Enhancement Activity	Explanation and Comments
Remove structures and/or non-native invasive vegetation and re-planting.	<p>This enhancement approach includes planting disturbed areas after structures have been removed from the site. Activities may include grading within the existing buffer to remove houses, driveways, and other structures. If necessary, soil will be scarified and/or amended with organic material.</p> <p>Non-native invasive species such as Himalayan and evergreen blackberry (<i>Rubus laciniatus</i>), Japanese knotweed, bamboo (<i>Bambusa</i> sp.), English holly will be removed from certain portions of the buffer; these areas are shown as shaded areas in Appendix B, Sheets L1 through L5.1. Removal of non-native invasive plants will depend upon vehicular access, the potential risk of sedimentation in wetlands or Miller Creek from vegetation removal, and whether or not invasive species can be controlled adequately without removal. Areas of non-native invasive species will be wholly removed only where there is appropriate access and if existing desirable vegetation will not be adversely affected.</p> <p>Re-vegetation will consist of planting native trees and shrubs in areas, such as lawns associated with residences, that do not currently have an overstory of vegetation. Under-planting will occur under existing tree canopies where an understory is absent or lacks diversity. Native trees and shrubs to be used in these enhancements are listed in Table 5.1-12.</p>
Invasive vegetation control and/or management, and re-planting with native vegetation.	<p>Non-native invasive species such as Himalayan and evergreen blackberry, Japanese knotweed, bamboo, English holly will be controlled and managed in certain portions of the buffer where removal is not necessary or possible. For example, invasive species within the buffer may be left in place if removal could cause erosion or sedimentation to the stream or adjacent wetlands.</p> <p>In some areas, patches of invasive species may be treated with herbicide and/or physically removed. These patches may range in size from approximately 200 to 600 ft². Coniferous tree species will be planted in the open area to promote reforestation that would eventually shade out invasive species. These plantings will also provide diversity, seed stock, and recruitment of LWD into the riparian buffer.</p>
Infill planting in existing native/non-native vegetation.	<p>Native trees and shrubs will be planted to increase (1) the amount of shade over Miller Creek, (2) LWD recruitment, and (3) colonization of native trees.</p> <p>Native trees and shrubs will be planted to increase (1) the amount of shade over Miller Creek, (2) LWD recruitment, and (3) colonization of native trees.</p>
No enhancement action needed.	<p>These areas either (1) contain well-vegetated buffer that does not require enhancement activities, (2) are inaccessible or cannot be enhanced without causing harm to desirable vegetation.</p>

Table 5.2-3. Final performance standards, evaluation approach, and contingency measures for wetland and buffer enhancement along Miller Creek.

Design Criteria	Performance Standard	Evaluation Approach	Contingency Measures ¹
Demolish existing structures, remove maintained lawn, landscaping, and portions of non-native vegetation located within 100 ft of Miller Creek (or its riparian wetlands), and buffer averaging areas (40-acres total).	Structures, landscaped lawns, gardens, etc and gardens will be absent from the 40 acre Miller Creek wetland and buffer enhancement area. The enhancement area will total 40 acres.	Verify with record drawings and field surveys.	If necessary remove additional structures to be consistent with design. Add additional area if as-built condition is not consistent with design.
Remove potential water quality impacts such as failed septic systems.	No septic systems will remain in the buffer area.	Verify with demolition records.	Remove any additional septic tanks if present.
Riparian buffer areas that are cleared or disturbed during demolition will be planted with native forested and shrub vegetation (these are shaded in Appendix B, Sheets L.1 through L.5.1). Plant native tree species at densities of greater than 280 per acre. Plant native shrub species at densities of greater than 2,100 per acre.	Average survival of planted stock will be at least 80% in the first 3 monitoring years. At this time, tree density will be at least 280 stems/acre; shrub density will be at least 2,100 individuals per acre. By the end of year 3, plant diversity in each stratum will not decrease by more than 10% from the number and type of plants installed at baseline. Canopy cover of native species will be at least 80% at monitoring year 10. Canopy cover of non-native, invasive species will not be more than 10% at monitoring year 10 (see Appendix B, Sheets L.1 through L.5.1 for locations where this standard will apply).	Vegetation sampling (plots, transects, or plotless techniques) to estimate cover, density, mortality, and invasive species.	If standards are not met: <ul style="list-style-type: none"> Select species that are better adapted to existing hydrologic conditions. Install additional plant material. Install protective collars to reduce herbivore damage..
Lawn areas and other areas dominated by non-native species, will be enhanced by planting native forested vegetation.	Average survival of planted stock will be at least 80% in the first 3 monitoring years. At this time, tree density will be at least 280 stems/acre; shrub density will be at least 2,100 individuals per acre. By the end of year 3, plant diversity in each stratum will not decrease by more than 10% from the number and type of plants installed at baseline.	See above.	See above.

Table 5.2-3. Final performance standards, evaluation approach, and contingency measures for wetland and buffer enhancement along Miller Creek (continued).

Design Criteria	Performance Standard	Evaluation Approach	Contingency Measures¹
	Canopy cover of native species will be at least 80% at monitoring year 10.		
Densely plant the portion of the buffer adjacent to Miller Creek with native trees and shrubs where applicable to provide future sources of LWD to the stream.	Percent of stream with overhanging canopy cover is the same as or greater than baseline (as-built) conditions. Density of trees in buffer is at least 280 stems/acre.	See above.	See above.
Remove existing structures, such as riprap walls and bridges, to reduce channel scouring.	Natural channel banks will be present in the buffer, as shown on plans.	Record drawings and field surveys.	Remove any structures found inconsistent with design sheets.
Establish restrictive covenants to permanently protect buffer.	A minimum of 40 acres of buffer is protected by restrictive covenants.	Record survey and comparison to design sheet. Verify restrictive covenants have been filed.	Implement any enhancement shown on plan sheets.
Install fencing and signs to designate area as protected mitigation site.	Signs and fencing clearly mark the buffer edge as a protected mitigation site.	Check signs and fencing during annual monitoring visits	Repair and/or re-install damaged or missing signs.

¹ For all performance standards, monitoring periods may be extended if performance standards are not met.

Expected Hydrology

The hydrologic regime within the buffer area along Miller Creek varies widely because of topography, soil conditions, and proximity to the stream or associated wetlands. Surface grades will be changed as little as possible to retain existing drainage and flow patterns. Therefore, no changes to the existing hydrologic regime are anticipated to occur from implementing this mitigation plan.

Hazard Wildlife Considerations

A landscape planting approach has been developed consistent with the WHMP to aid in deterring flocking birds, raptors, and waterfowl from using the buffer areas along Miller Creek as habitat. Mitigation actions in the buffer, such as replacing the existing open areas (i.e., lawns) along the stream with forested and shrub vegetation, will reduce hazard wildlife attractants by covering and screening open water.

To deter raptor use of the mitigation sites, deciduous and coniferous trees with stiff branches (such as Sitka spruce or Douglas fir) will be planted in limited quantities to limit roosting habitat for raptors such as red-tailed hawks. The primary coniferous tree species used in the upland and transitional zones will be western redcedar because its limp branches do not provide ideal raptor perching habitat.

Landscape Plan

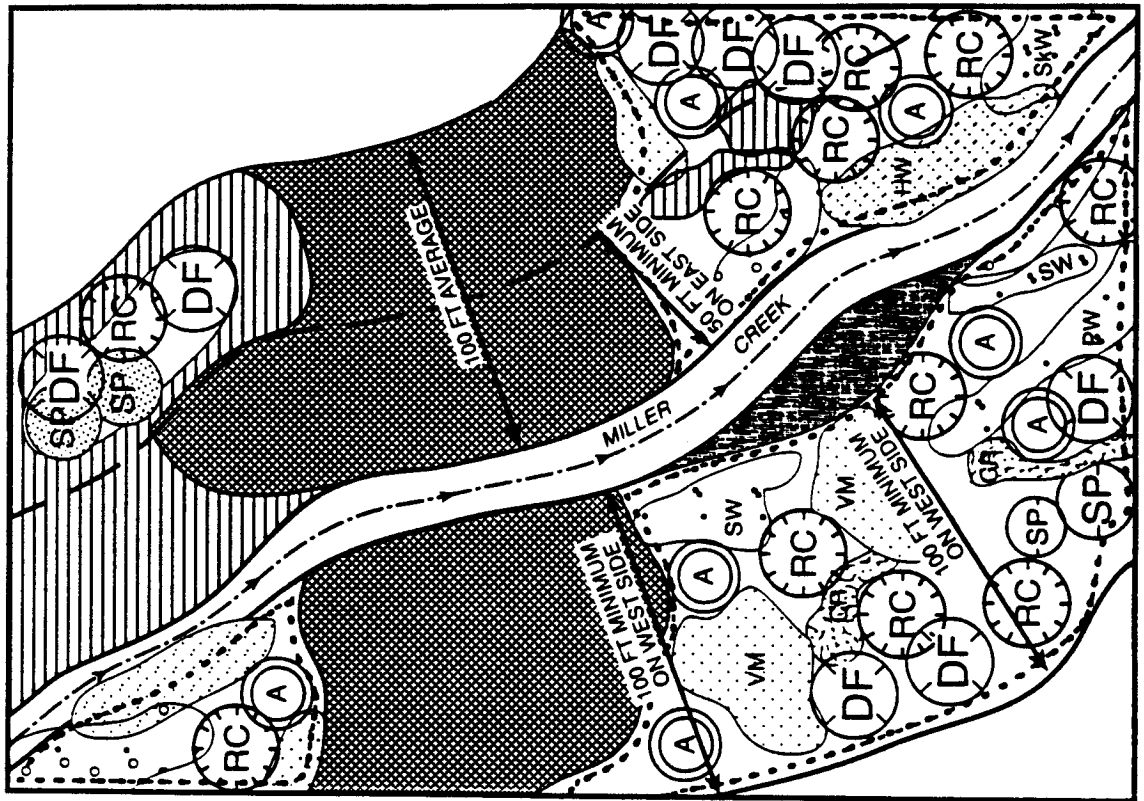
Specific planting plans for each area within the buffer have been designed using the buffer area inventory and the four enhancement alternatives (see Table 5.2-2). Plant communities and specific planting zones are shown in detail on plan sheets included in Appendix B, Sheets L1 through L5.1.




A list of plant species similar to that identified for the Miller Creek floodplain and wetland restoration (see Table 5.1-12) will be used in the Miller Creek riparian corridor buffer enhancement plan. Sun-tolerant species, such as Douglas fir and red alder, will be planted in open sunny areas, while species that prefer shade, such as vine maple (*Acer circinatum*), will be planted in shady areas under existing vegetation. A typical planting plan (Figure 5.2-3) depicts how these planting approaches will be applied.














Temporary irrigation will be provided within the buffer areas. Irrigation will only be used during the plant establishment phase and will either be removed (if installed above ground) or abandoned in place (if installed below ground).

5.2.1.8 Implementation

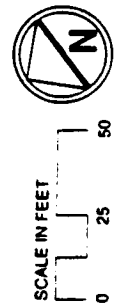
Miller Creek buffer projects will be closely coordinated with the instream enhancement projects, as well as related Master Plan Update improvements, such as construction of the embankment. Construction methods, sequencing, and steps necessary to implement both the riparian wetland and buffer enhancement projects and the instream enhancement projects are discussed in Section 5.2.2.10.



-  Existing vegetation to remain
-  Area of existing non-native invasive plant species to be removed and replaced with native riparian trees and shrubs
-  Areas for partial non-native plant removal. Native coniferous trees will be planted to provide shading

Riparian Floodplain Zone	Upland Zone
TREES	TREES
 Western Redcedar	 Douglas Fir
 Red Alder	 Sitka Spruce
 Oregon Ash	 Western Red Cedar
SHRUBS	 Red Alder
 Sitka Willow	SHRUBS
 Pacific Willow	 Vine Maple
 Hooker's Willow	 Clustered Rose
 Hydroseed Mix/ Natural Colonization	

Port of Seattle/Natural Resource Mitigation Plan#556 2912.001/01(03) 12/00 (K)



**Figure 5.2-3
Typical Planting Plan
for the Miller Creek Upland and
Streamside Buffer Planting Zones**

5.2.1.9 Monitoring and Performance Standards

Monitoring for the wetland and riparian buffer projects will be consistent with the monitoring approach and schedule outlined in Chapter 4. Specific performance standards will be evaluated regularly during the monitoring period to ensure that the wetland and riparian buffer enhancement projects are meeting project goals and objectives (see Table 5.2-3). If performance standards are not met, specific contingency measures listed in Table 5.2-3 may be implemented, following the adaptive management approach described in Chapter 4. Monitoring schedules specific to the riparian buffer are provided in Table 5.2-4.

5.2.1.10 Site Protection

The Port will execute and file a restrictive covenant for the Mitigation area. Copies of proposed restrictive covenants are included in Appendix F.

The Miller Creek buffer mitigation will be marked with permanent signs and protected by fencing as approved by ACOE. Signs will clearly mark the area as a protected wetland mitigation site. The Port will inspect and maintain signs and fencing on a regular basis.

5.2.1.11 Maintenance and Contingency Plans

Routine maintenance tasks (e.g., maintaining irrigation system, removing trash) and adaptive management/contingency measures (e.g., weed management, replacing plants) will be implemented consistent with the approach outlined in Chapter 4. Specific contingency actions for each wetland and riparian buffer performance standard are provided in Table 5.2-3.

5.2.2 Miller Creek Instream Habitat Enhancement Plan

Four major instream enhancement projects, as well as general instream habitat enhancements to restore and improve the quality of fish habitat in Miller Creek. Instream habitat quality is currently degraded as a result of historic residential land uses and overall urbanization in the basin (see Chapter 2).

The section of Miller Creek between the Vacca Farm site and Des Moines Memorial Drive was surveyed in February and March 1999 to identify areas within the stream channel that would benefit from habitat enhancement. As a result of this survey, four enhancement projects have been identified (Appendix B, Sheet C2). Habitat enhancement in these four projects includes removal of channel armoring, weirs, concrete walls, and footbridges, and installing instream features such as root wads, gravel, and large woody debris. In addition to these four instream enhancement projects, large woody debris will be added at selected locations along the 6,500-ft section of Miller Creek to enhance overall channel function and habitat (Appendix B, Sheets C7 and C10). Instream enhancement projects will be coordinated with the wetland and riparian buffer enhancement projects. The streambed and bank of Miller Creek adjacent to the South 156th Street bridge will also be restored after the existing bridge over South 156th Street is removed and reconstructed as part of relocating South 154th Street (see Figure 5.2-1).

Table 5.2-4. Monitoring schedule for the Miller Creek buffer and wetland enhancement project.

Feature	Method	Duration	Data Collection Year																	
			0	1	2	3	4	5	6	7	8	9	10							
Plant survival	Calculating plant survival.	Once late spring to early summer	X	X	X	X	X													
Tree and shrub density/cover	Vegetation sampling	Once late spring to early summer	X	X	X	X	X													
Vegetation structure	Describe from walk-through surveys, incorporating data from above analysis as available.	Once late spring to early summer	X	X	X	X	X													

AR 048751

Natural Resource Mitigation Plan
 Seattle-Tacoma International Airport
 Master Plan Update

5-72

December 2000
 556-2912-001 (01) (03)

G:\DATA\workings\912555\912555\9103\regul_2000\NRM\PC\current\version\Master_2.doc

5.2.2.1 Goals, Objectives, and Design Criteria

The overall goal of the Miller Creek instream enhancement projects is to alleviate historic human disturbances by increasing the amount, quality, and continuity of instream fish habitat. Specific design objectives in the instream enhancement projects are:

- Enhance instream fish habitat by increasing channel complexity.
- Stabilize bed and bank erosion along Miller Creek.
- Remove instream man-made debris and channel armoring.
- Enhance instream substrate conditions for fish and invertebrates.
- Restore the streambed and bank after relocating the bridge over South 156th Street.

To implement the goal identified above, specific objectives and design criteria were developed (Table 5.2-5).

Table 5.2-5. Mitigation goals, design objectives, and design criteria for instream enhancement projects in Miller Creek.

Goals and Design Objectives	Design Criteria
Goal 1: Enhance habitat by increasing channel complexity	
Create pools and riffle habitat.	Remove cemented riprap along banks, encourage natural formation of meander bends and cut benches.
Create undercut banks and other habitat features for juvenile rearing and high-flow refugia.	Increase the amount of geomorphically stable large organic debris in the channel.
Create instream diversity.	
Goal 2: Stabilize bed and bank erosion	
Identify locations of in-channel or bank erosion and stabilize those areas.	Stabilize those areas of excessive erosion by using native vegetation and large woody debris.
Goal 3: Remove trash	
Channel will be free of trash.	Remove all trash from the channel that could be harmful to fish habitat aesthetics, and water quality.
Goal 4: Enhance instream substrate	
Enhance substrate.	Add gravel to degraded reaches where natural recruitment is limited.
Goal 5: Restore the bed and bank after relocating the bridge at South 156th Street	
Reduce fine sediment load.	Reduce upstream erosion by vegetating banks and replanting the Vacca Farm site.

5.2.2.2 Mitigation Site Description

The four instream enhancement projects, and the general habitat enhancements are located in Miller Creek between the Vacca Farm site and Des Moines Memorial Drive (see Figure 5.2-1; Appendix B, Sheet C2).

Between Vacca Farm and South 160th Street, the stream channel is slightly less altered than the ditched and channelized reach on the Vacca Farm site. South of Vacca Farm, the stream contains some meanders, pools and riffles, and some large woody debris in the channel. The substrate is predominantly silty, mixed with areas of sand and till in the northern portions of this reach. Further downstream the substrate consists largely of gravel and gravel-sand bars. Unconfined channel widths in this reach range from 7 to 10 ft and gravel bars are approximately 5 ft wide. Because this stream reach has been surrounded by residences and yards, several stream portions are modified with riprap, retaining walls, bridge abutments, footbridges, and other bank-side structures that restrict natural channel morphology. The vegetated upland buffer in this area mostly consists of lawn and some bushes and trees planted by homeowners, but there is very little native riparian vegetation.

The stream channel between South 160th Street and SR 509 is less disturbed than the upstream reaches, with channel widths ranging from 7 to 10 ft. With the exception of a few small stretches within this reach, which have been modified with riprap, tire walls, or fences, this reach is characterized by meanders, large woody debris jams, riparian vegetation, pools and riffles, and gravel bars. Generally, residential development is located farther from the stream than in the upstream reaches. As a result, long stretches of the stream have intact riparian vegetation on both banks, reducing the impact of urbanization. Gravel and sandbars are present in many portions of this reach and substrate in the majority of the channel is gravel.

5.2.2.3 Ownership

The Port owns the entire area to be included in the Miller Creek riparian and instream enhancement mitigation.

5.2.2.4 Rationale for Selection

Mitigation sites for the specific instream enhancement projects were selected based on several criteria. An initial survey of existing conditions was conducted to identify locations where development adjacent to the channel or alterations to the channel were directly impairing habitat and/or water quality in Miller Creek. These sites were then evaluated based on the severity and type of impact and opportunity for restoration. Type of impact included the loss of habitat complexity, channel armoring, erosion, man-made debris in the channel, and unstable or uniform geomorphology. Opportunity for significant improvement at potential enhancement sites was determined based on benefits to upstream and downstream reaches, access to the site, coordination with buffer revegetation projects, and potential negative impacts during construction.

5.2.2.5 Constraints

There are no significant constraints to the implementation of the mitigation projects. However, instream work must be performed during low-flow periods, and all work will be designed and performed consistent with conditions of the HPA permit for the projects.

5.2.2.6 Ecological Assessment of the Enhancement Sites

Urban development in the Miller Creek watershed has degraded instream habitat and water quality throughout the basin. Specifically, within the project reach, aquatic habitat has been degraded by altered hydrology; channelization; excess fine sediments; altered water quality due to inputs of pollutants, stormwater discharges, and agricultural and residential herbicides, pesticides, and fertilizers; loss of habitat complexity; and loss of vegetated buffers (Table 5.2-6). However, Miller Creek continues to support populations of coho salmon, anadromous and resident cutthroat trout, three-spine sticklebacks, white crappie (*Pomoxis annularis*), and pumpkinseed sunfish.

Table 5.2-6. Summary of existing conditions in Miller Creek between South 156th Street and Des Moines Memorial Drive.

Parameter	Description
Fish Habitat	Pool habitat and high-flow refugia quality are relatively poor, which is related to the lack of LWD in the channel. This problem (and other factors) may limit the sizes of resident and anadromous fish populations supported by Miller Creek.
Fine Sediment	High turbidity was observed (and reported) in Miller Creek during winter base flow rates. This problem is primarily found in the upper reaches where the channel has been straightened and confined by riprap on both banks.
Geomorphic Complexity	Numerous footbridges and riprap confine the stream to a narrow straight channel in many reaches.
Man-made Debris	Man-made debris (tires, shopping carts, metal pipes, and car parts) and fences that restrict upstream and downstream fish movement are common throughout the stream.

Between South 156th Street and the South 160th Street culvert, Miller Creek has been degraded by substantial development adjacent to the banks. Segments of the stream have been straightened and the banks in these reaches are lined with riprap or cement. Substrate in this reach consists of silt and fine sands. Numerous footbridges and weirs influence channel morphology and reduce habitat complexity. Most of the footbridges confine the channel, creating straightened reaches of high-velocity flows and bed scouring. Riparian vegetation consists primarily of lawn and some trees adjacent to the channel; however, the vegetation does not provide shade, bank stabilization, or habitat complexity. A fish survey conducted in 1998 found that sticklebacks were the dominant fish in this reach; white crappies were also found (Parametrix 1998). Although cutthroat trout were found upstream of waterfall north of 160th Street during an electroshocking fish survey on November 10, 1998 (Parametrix 1998), they were not found during that survey in the upper reaches of Miller Creek north of South 156th Street.

Specific conditions in each of the four instream project reaches are described in the following section.

Instream Enhancement Project 1

Instream Project 1 is located between the downstream end of the Miller Creek relocation project and South 156th Street (see Figure 5.2-1). The project area includes approximately 650 ft of Miller Creek, which is confined along most of the project length by riprap (Figure 5.2-4; Appendix B, Sheet C3). Historically, this area was a wetland that may have lacked a defined streambed. When this area was drained for farmland, Miller Creek was channelized along the eastern edge of Wetland A1. A small side channel, or ditch, draining Wetland A1 flows into Miller Creek at the south end of Wetland A1 (see Figure 5.2-4). This project is located on Parcels 63, 87, 88, 89, 90, 91, 97, 98, 100, and 101.

In this reach Miller Creek is a low-gradient stream, although the valley becomes more confined downstream of the confluence with the side channel. The project site has two distinct areas: upstream of the confluence with the side channel (Parcels 88, 89, and 90), and downstream of the confluence where the valley narrows (Parcels 91, 99, 100, and 101). Substrate in the upstream reach is composed primarily of silt and fine gravel; however, some coarse gravel exists where riprap has fallen into the channel and created a riffle. Substrate in the side channel and downstream of the confluence consists of fine silt. Five footbridges cross Miller Creek upstream of the confluence, and a fence crosses the channel at the upstream end of the project site. Two footbridges and a fence cross the side channel.

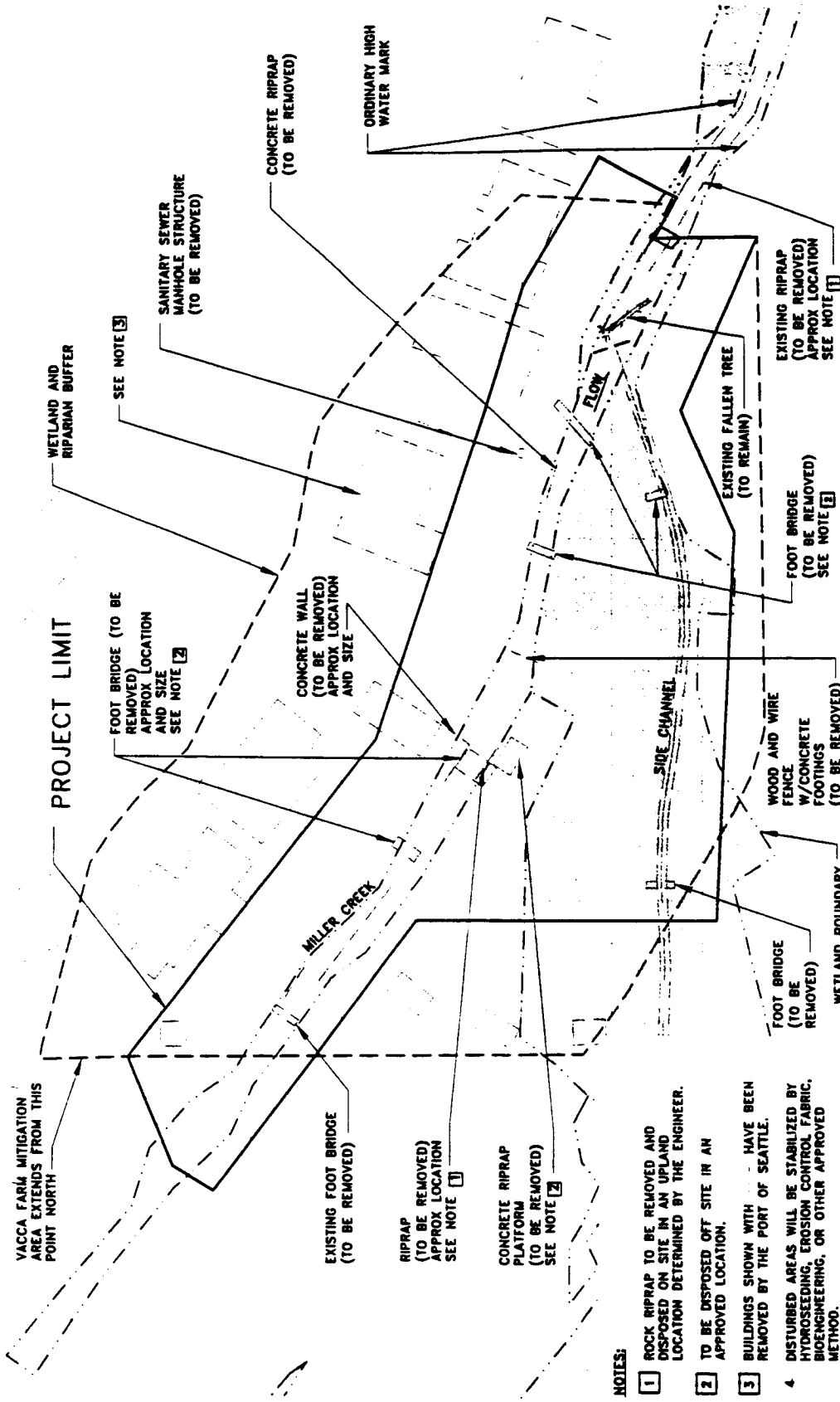
During high-flow events, both Miller Creek and the side channel overtop their banks and flood the adjacent wetland. Vegetation within this reach is predominantly grass; the site also has several large western redcedar trees and some non-native and invasive species. Downstream of the confluence several large trees are located along the channel; however, the remainder of vegetation is lawn and invasive or exotic species.

Existing Conditions: Instream Enhancement Project 2

Instream Project 2 is located approximately 150 ft upstream of South 160th Street (see Figure 5.2-1). A narrow ravine confines Miller Creek and its floodplain throughout this reach.

Construction of two weirs in this reach has altered the channel profile and resulted in a uniform channel with little habitat diversity (Figure 5.2-5; Appendix B, Sheet C4). The first (downstream) weir is approximately 3 ft high and constructed of large boulders. The second (upstream) weir is constructed of cement, located approximately 70 ft upstream of the first weir, and is approximately 2 ft high. A footbridge crosses Miller Creek just upstream of the second weir. Miller Creek is confined by riprap on both banks downstream of the first weir and upstream of the second weir. Both weirs may impede fish passage at summer low flows.

Between the weirs, riprap armors the left bank, while the right bank is covered with lawn. During storm events, a pool forms behind the downstream weir and floods the right bank. An emergent wetland lies adjacent to the left bank of Miller Creek throughout the project area.

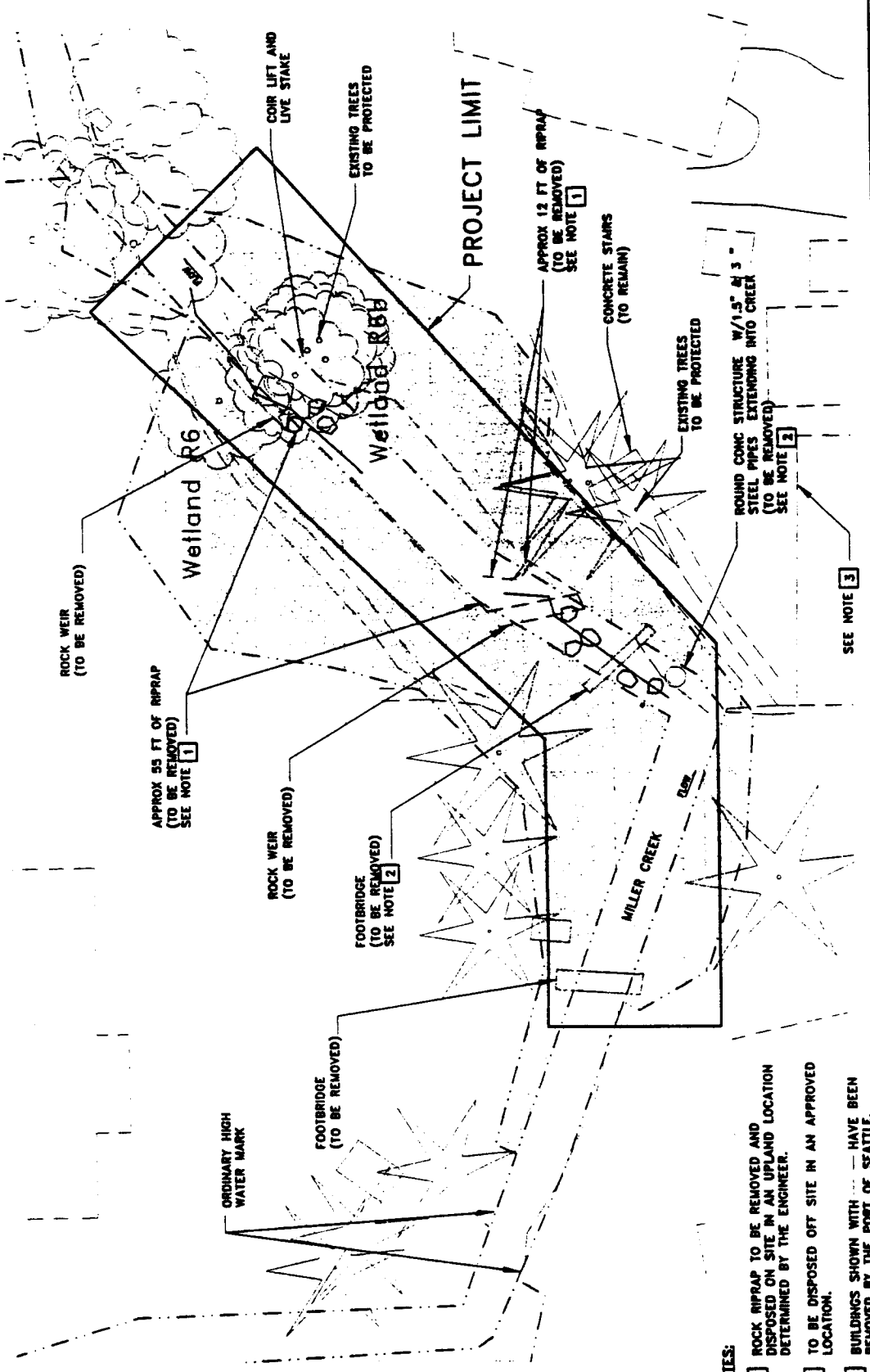


- NOTES:**
- 1 ROCK RIPRAP TO BE REMOVED AND DISPOSED ON SITE IN AN UPLAND LOCATION DETERMINED BY THE ENGINEER.
 - 2 TO BE DISPOSED OFF SITE IN AN APPROVED LOCATION.
 - 3 BUILDINGS SHOWN WITH [] HAVE BEEN REMOVED BY THE PORT OF SEATTLE.
 - 4 DISTURBED AREAS WILL BE STABILIZED BY HYDROSEEDING, EROSION CONTROL FABRIC, BIOENGINEERING, OR OTHER APPROVED METHOD.

FILE: 201203_FS.2-4.DWG
DATE: 11/28/00



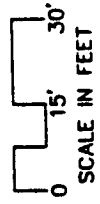
**Figure 5.2-4
Instream Project 1
Existing Conditions**



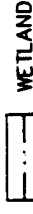
NOTES:

- 1 ROCK RIPRAP TO BE REMOVED AND DISPOSED ON SITE IN AN UPLAND LOCATION DETERMINED BY THE ENGINEER.
- 2 TO BE DISPOSED OFF SITE IN AN APPROVED LOCATION.
- 3 BUILDINGS SHOWN WITH --- HAVE BEEN REMOVED BY THE PORT OF SEATTLE.

FILE: 291203/52-5
DATE: 11/28/00



SCALE IN FEET



WETLAND



MILLER CREEK CHANNEL

**Figure 5.2-5
Instream Project 2
Existing Conditions**

Vegetation in the project area is predominantly turf grass lawns; however, a stand of large cottonwood trees is located on the right bank near the downstream weir. The project site is easily accessible on the right bank, although heavy equipment access may be limited by a retaining wall on the left bank.

Instream Enhancement Project 3

The site of Instream Project 3 extends from a scour pool and debris area immediately downstream of a culvert at South 160th Street to approximately 600 ft downstream (see Figure 5.2-1; Appendix B, Sheets C2 and C5). This project is located on Parcels 256, 257, 258, 259, 260, and 276. Miller Creek is confined in the middle and upper portions of this site by a narrow ravine. However, along the lower project reaches, the valley widens and an extensive floodplain and wetland are associated with the stream.

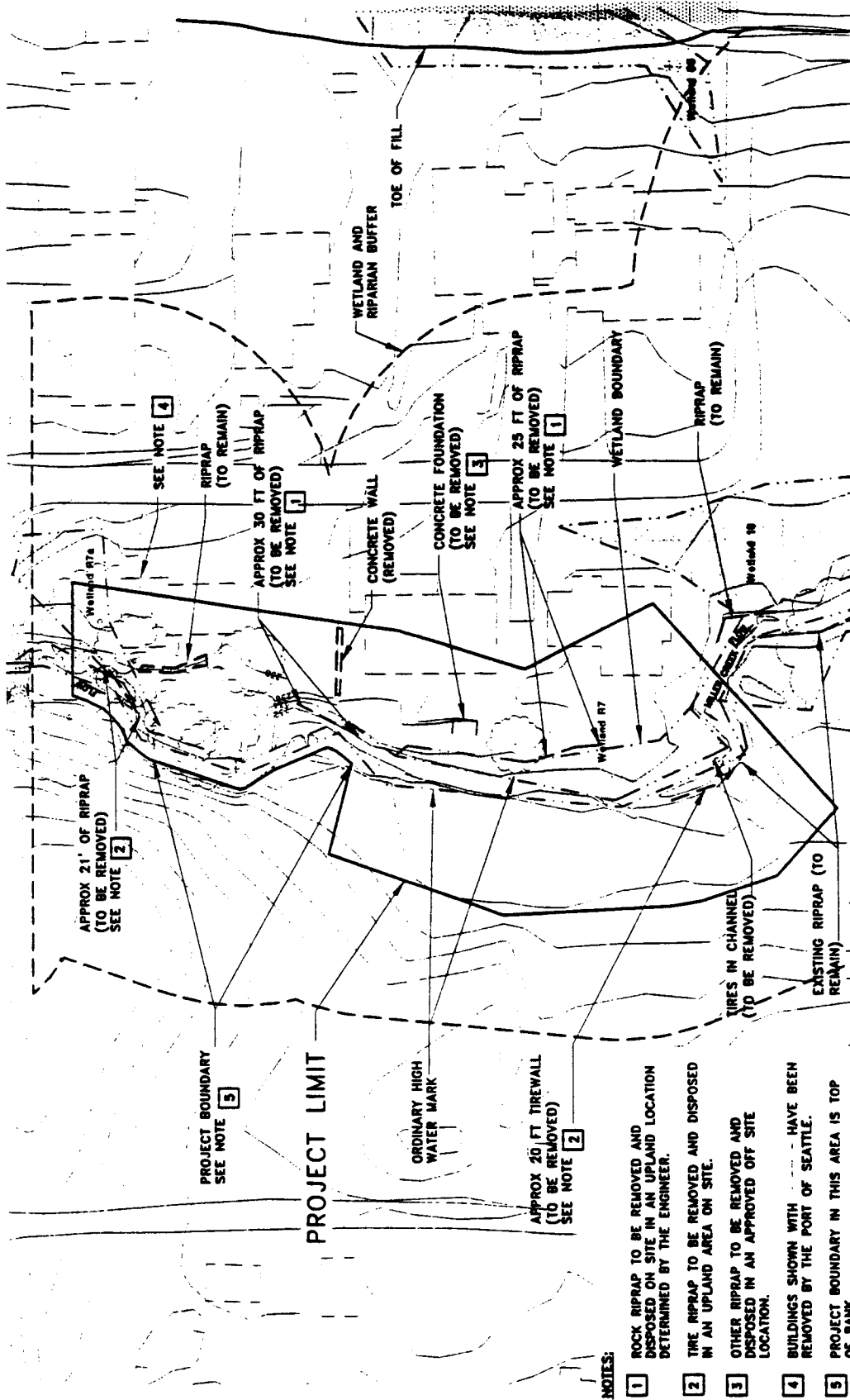
Tire riprap has been placed along the left bank downstream of the scour pool, while the right bank is steep and shows evidence of erosion and downcutting. In the middle of the project site, Miller Creek becomes confined to a narrow channel, the gradient increases to a slope of approximately 3 percent, and the velocity increases. At the lower end of the steep reach, Miller Creek has a sharp meander bend that is protected by riprap (Figure 5.2-6; Appendix B, Sheet C5). Tire riprap lines the channel approximately 40 ft upstream of this meander. A deep scour pool with large cobble substrate has formed on the outside edge of the meander. Another meander immediately downstream has also been lined with riprap.

Vegetation throughout this reach is dominated by blackberry species and turf grass lawn, with a few large trees scattered along the banks. Access to the site is limited by steep banks on the right bank immediately downstream of the culvert. However, the project area is easily accessible along the left bank.

Instream Enhancement Project 4

Enhancement Project 4 extends from a point east of 8th Avenue South to a private driveway approximately 820 ft upstream (see Figure 5.2-1). Project 4 is located on Parcels 314, 316, 317, and 321. Many reaches of Miller Creek throughout this project area are unconfined by riprap and have pool and riffle sequences; small pieces of in-channel wood are present throughout this reach as well. Riprap lines the bank downstream of the private driveway (Figure 5.2-7; Appendix B, Sheet C6). Large cement pieces line Miller Creek on the right bank, constricting the channel. A collapsed footbridge has created a backwater pool and trapped debris on the upstream side during winter base flow conditions. At the downstream portion of the project area, two rock walls line the stream and a fence spans the channel. The upstream wall, located along the left bank, influences the flow pattern of the stream; however, there is evidence of bank erosion downstream of this wall. Miller Creek is channelized by the second wall, which lines both banks.

Riparian vegetation in the project site includes many large (>30 ft) western redcedar and red alder trees; however, little understory exists, and ground cover is primarily grass, gravel, and invasive species such as blackberry. Steep banks at specific locations on the left bank would limit site access. Miller Creek is easily accessible in most places along the right bank.



NOTES:

- 1 ROCK RIPRAP TO BE REMOVED AND DISPOSED ON SITE IN AN UPLAND LOCATION DETERMINED BY THE ENGINEER.
- 2 TIRE RIPRAP TO BE REMOVED AND DISPOSED IN AN UPLAND AREA ON SITE.
- 3 OTHER RIPRAP TO BE REMOVED AND DISPOSED IN AN APPROVED OFF SITE LOCATION.
- 4 BUILDINGS SHOWN WITH DASHED LINES HAVE BEEN REMOVED BY THE PORT OF SEATTLE.
- 5 PROJECT BOUNDARY IN THIS AREA IS TOP OF BANK.

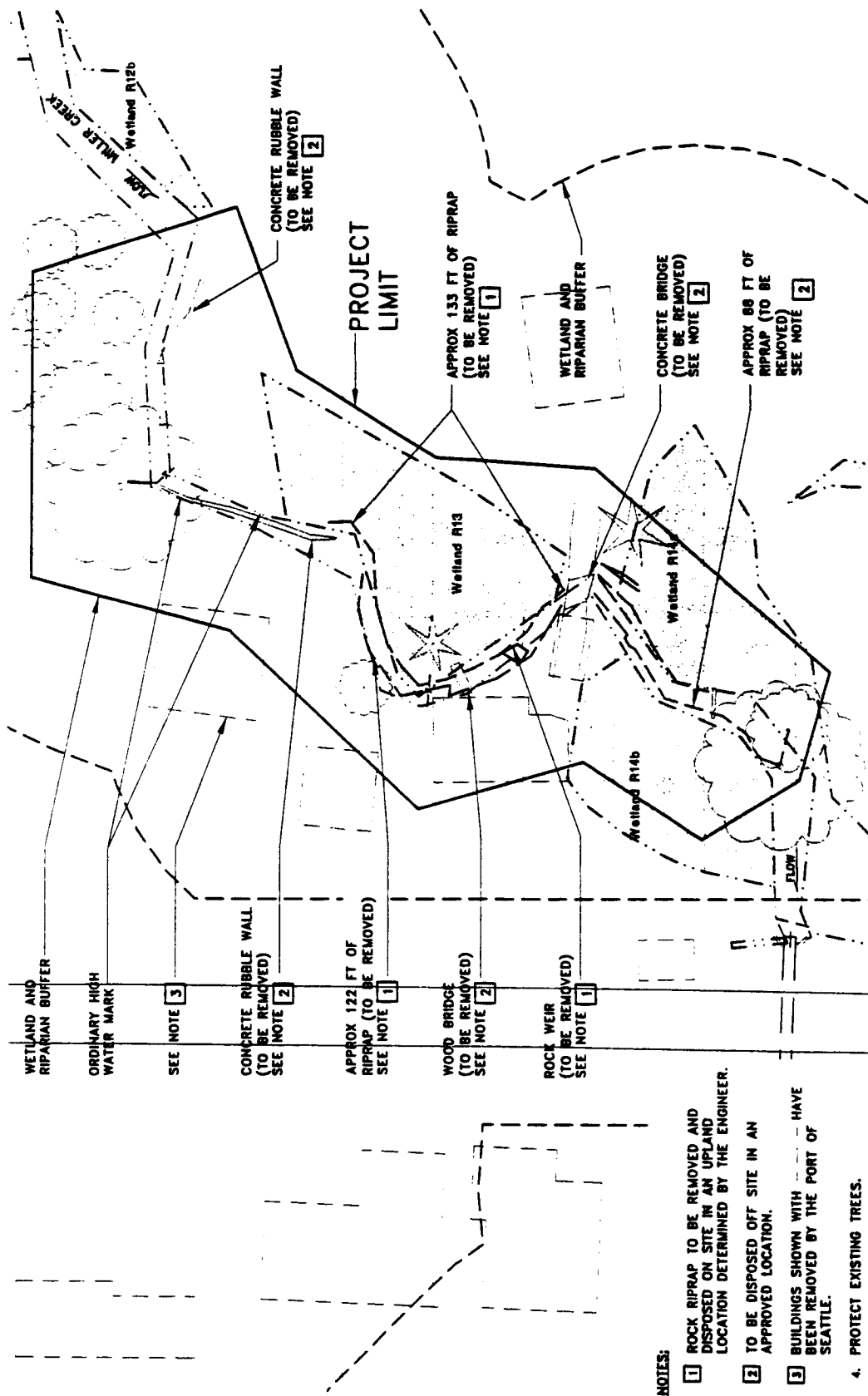
FILE: 201203_05.2-4
DATE: 11/27/00



- WETLAND
- MILLER CREEK CHANNEL

Figure 5.2-6
Instream Project 3
Existing Conditions

Parametrix, Inc.



NOTES:

- 1 ROCK RIPRAP TO BE REMOVED AND DISPOSED ON SITE IN AN UPLAND LOCATION DETERMINED BY THE ENGINEER.
- 2 TO BE DISPOSED OFF SITE IN AN APPROVED LOCATION.
- 3 BUILDINGS SHOWN WITH --- HAVE BEEN REMOVED BY THE PORT OF SEATTLE.
- 4. PROTECT EXISTING TREES.

FILE: 201203.J5
DATE: 11/28/00



**Figure 5.2-7
Instream Project 4
Existing Conditions**

5.2.2.7 Instream Habitat Enhancements Mitigation Design

The following sections describe the mitigation actions proposed for the four specific instream habitat enhancement projects, the general in-stream habitat enhancement along Miller Creek, and the restoration of the stream for the South 156th Street bridge relocation.

Most channel armoring, rock walls, weirs, and footbridges along this reach of Miller Creek will be removed. For example, the existing rock weirs located at Instream Project 2 will be removed because they impede fish passage. However, at several locations some riprap will be left in the channel to avoid creating significant erosion or construction impacts (Figures 5.2-8 through 5.2-11).

Prior to developing the enhancement designs, cross sections were surveyed in three relatively undisturbed reaches in Miller Creek. These cross sections (Figure 5.2-12) are used as reference sites for proposed instream enhancement projects. The geomorphic and habitat benefits associated with each enhancement feature are summarized in Table 5.2-7.

Table 5.2-7. Habitat and geomorphic benefits of Miller Creek instream enhancement features.

Enhancement Feature	Geomorphic Function	Habitat Function
Large Woody Debris (LWD)	Stabilizes banks	Increases habitat complexity
	Promotes deposition of fine sediment	Promotes pool formation Provides instream cover
Riparian Vegetation	Stabilizes banks	Moderates temperature
	Provides a source for LWD recruitment	Provides organic matter
	Increases roughness, promotes deposition of fine sediment	Promotes undercut banks Provides instream cover
Meander Bends	Creates pool/riffle sequences	Increases habitat complexity
	Promotes overbank flows, reduces channel incision	Creates spawning reaches
	Creates variations in flow regime	
	Creates depositional areas	
Boulders	Promotes variation in channel width	Provides instream cover
	Creates variations in flow regime	Creates variations in flow regime
Erosion Control	Reduces sediment loading	Reduces spawning habitat degradation
	Stabilizes banks	Increases macroinvertebrate production
Remove Instream Barriers	Promotes natural geomorphic processes (i.e., widening, meandering, deposition)	Increases habitat availability/continuity
Debris Removal	NA	Enhances aesthetics
		Reduces potential pollutants
Remove Footbridges/Riprap	Allows for natural channel movement (i.e., widening, meandering, deposition)	Increase habitat complexity

NA = Not applicable

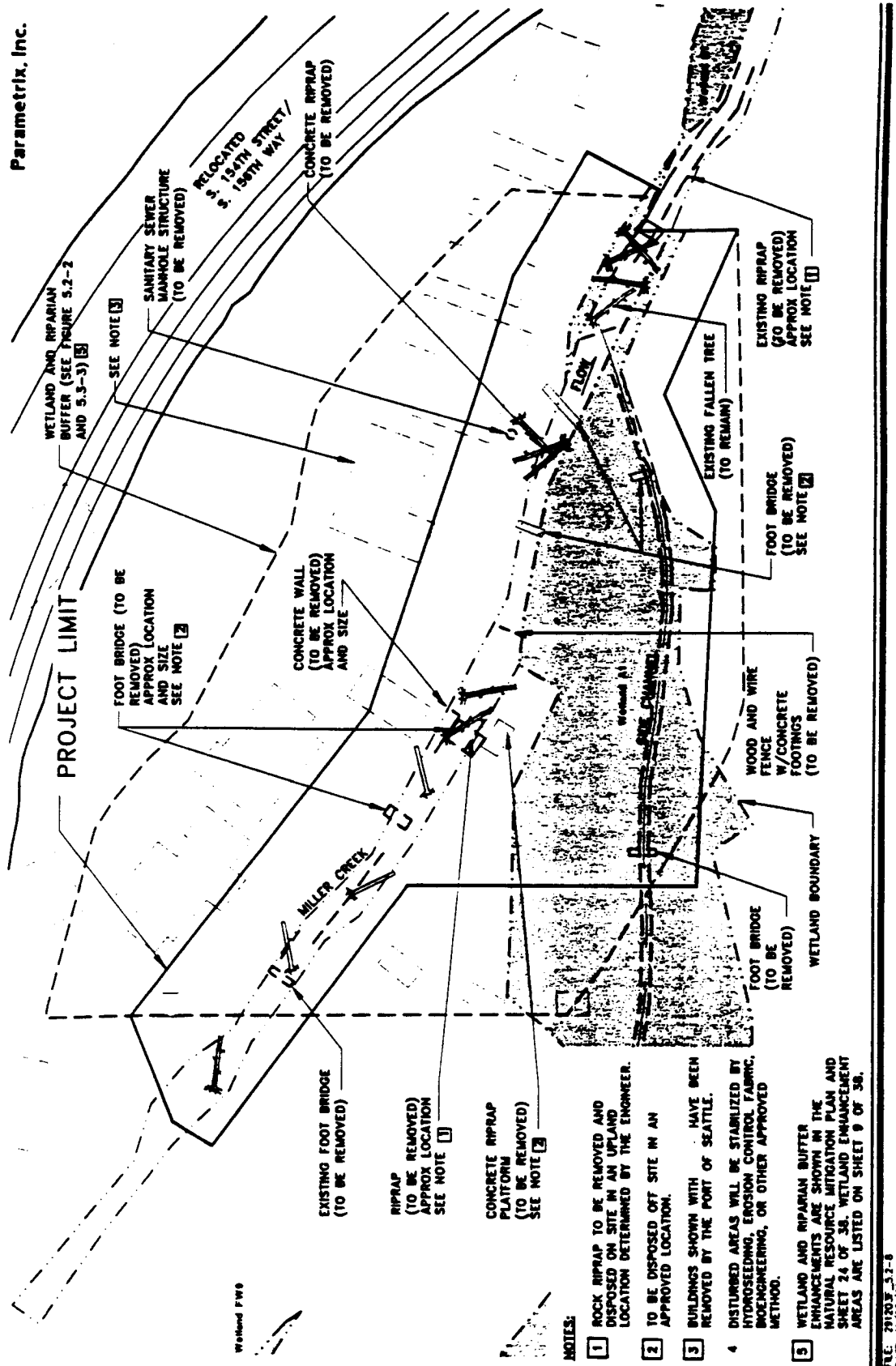


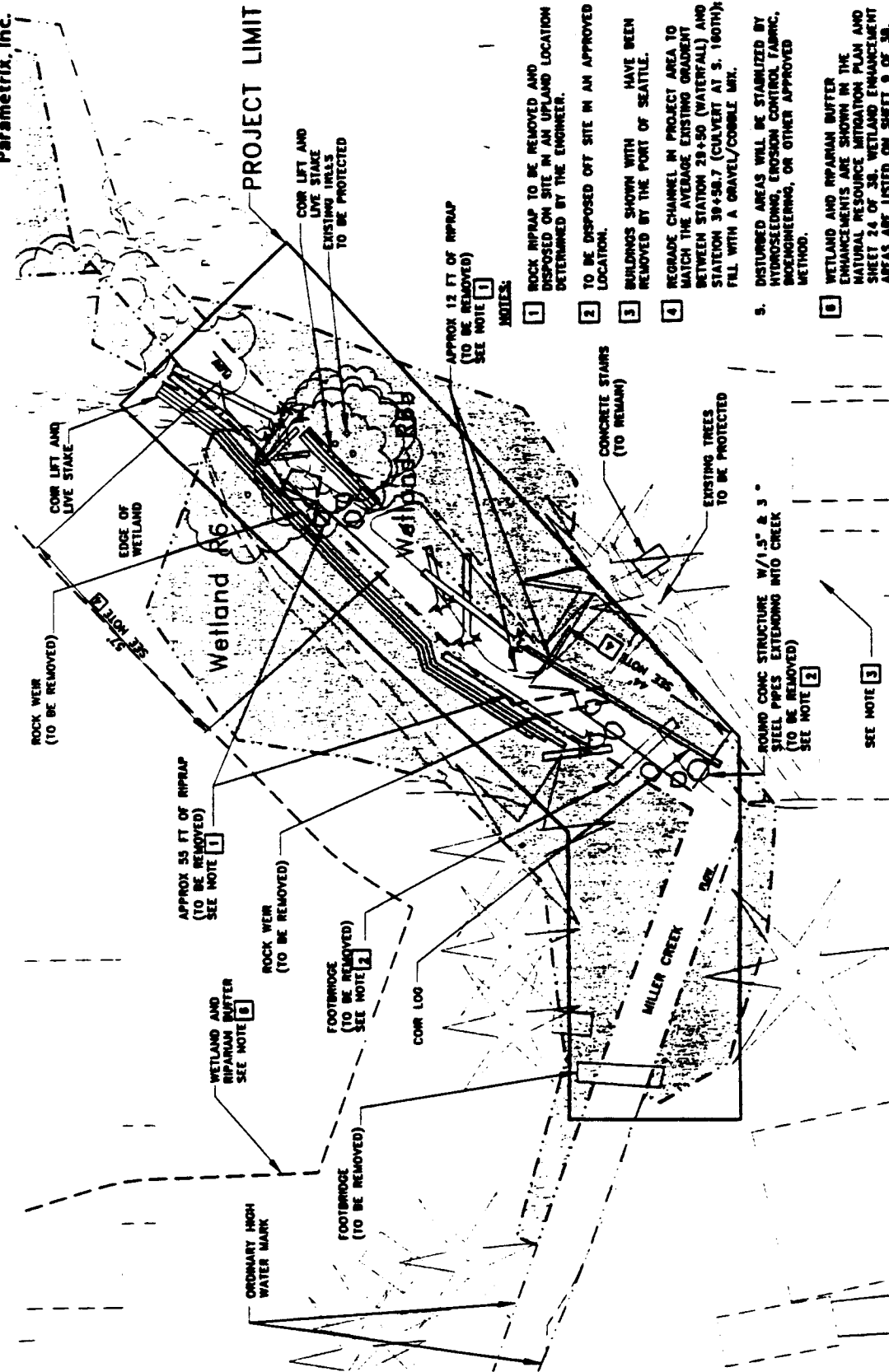
Figure 5.2-8
 Instream Project 1
 Proposed Condition

- NOTES:**
- 1 ROCK RIPRAP TO BE REMOVED AND DISPOSED ON SITE IN AN UPLAND LOCATION DETERMINED BY THE ENGINEER.
 - 2 TO BE DISPOSED OFF SITE IN AN APPROVED LOCATION.
 - 3 BUILDINGS SHOWN WITH HAVE BEEN REMOVED BY THE PORT OF SEATTLE.
 - 4 DISTURBED AREAS WILL BE STABILIZED BY HYDROSEEDING, EROSION CONTROL FABRIC, BIOENGINEERING, OR OTHER APPROVED METHOD.
 - 5 WETLAND AND RIPARIAN BUFFER ENHANCEMENTS ARE SHOWN IN THE NATURAL RESOURCE MITIGATION PLAN AND SHEET 24 OF 38. WETLAND ENHANCEMENT AREAS ARE LISTED ON SHEET 9 OF 38.

FILE: 171933_5.2-8
 DATE: 11/26/00

0 30 60
 SCALE IN FEET

WETLAND
 MILLER CREEK CHANNEL



- NOTES:**
- 1 ROCK RIPRAP TO BE REMOVED AND DISPOSED ON SITE IN AN UPLAND LOCATION DETERMINED BY THE ENGINEER.
 - 2 TO BE DISPOSED OFF SITE IN AN APPROVED LOCATION.
 - 3 BUILDINGS SHOWN WITH HAVE BEEN REMOVED BY THE PORT OF SEATTLE.
 - 4 REGRADE CHANNEL IN PROJECT AREA TO MATCH THE AVERAGE EXISTING GRADE BETWEEN STATION 29+50 (WATERFALL) AND STATION 39+58.7 (CULVERT AT S. 160TH); FILL WITH A GRAVEL/COBBLE MIX.
 - 5 DISTURBED AREAS WILL BE STABILIZED BY HYDROSEEDING, EROSION CONTROL FABRIC, SODDING, OR OTHER APPROVED METHOD.
 - 6 WETLAND AND RIPARIAN BUFFER ENHANCEMENTS ARE SHOWN IN THE NATURAL RESOURCE MITIGATION PLAN AND SHEET 24 OF 38. WETLAND ENHANCEMENT AREAS ARE LISTED ON SHEET 9 OF 38.

**Figure 5.2-9
Instream Project 2
Proposed Conditions**

FILE: 211207.3.2-9
DATE: 11/28/00



LEGEND

- WETLAND
- MILLER CREEK CHANNEL

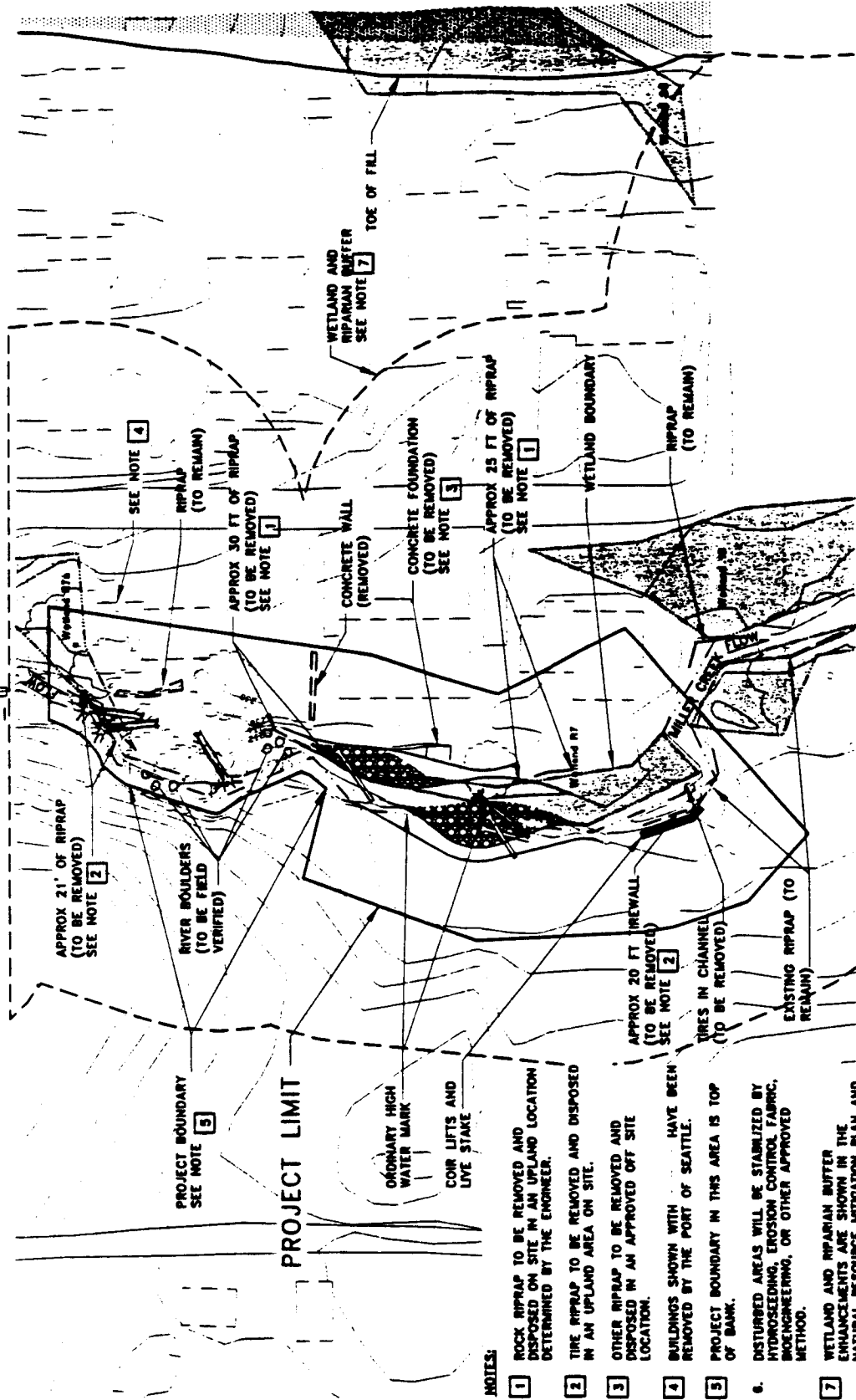


Figure 5.2-10
Instream Project 3
Proposed Conditions

NOTES:

- 1 ROCK RIPRAP TO BE REMOVED AND DISPOSED ON SITE IN AN UPLAND LOCATION DETERMINED BY THE ENGINEER.
- 2 TIRE RIPRAP TO BE REMOVED AND DISPOSED IN AN UPLAND AREA ON SITE.
- 3 OTHER RIPRAP TO BE REMOVED AND DISPOSED IN AN APPROVED OFF SITE LOCATION.
- 4 BUILDINGS SHOWN WITH ... HAVE BEEN REMOVED BY THE PORT OF SEATTLE.
- 5 PROJECT BOUNDARY IN THIS AREA IS TOP OF BANK.
- 6 DISTURBED AREAS WILL BE STABILIZED BY HYDROSEEDING, EROSION CONTROL FABRIC, BIOENGINEERING, OR OTHER APPROVED METHOD.
- 7 WETLAND AND RIPARIAN BUFFER ENHANCEMENTS ARE SHOWN IN THE NATURAL RESOURCE MITIGATION PLAN AND SHEET 24 OF 38. WETLAND ENHANCEMENT AREAS ARE LISTED ON SHEET 9 OF 38.

FILE: 291203_5.2-10
DATE: 11/29/00

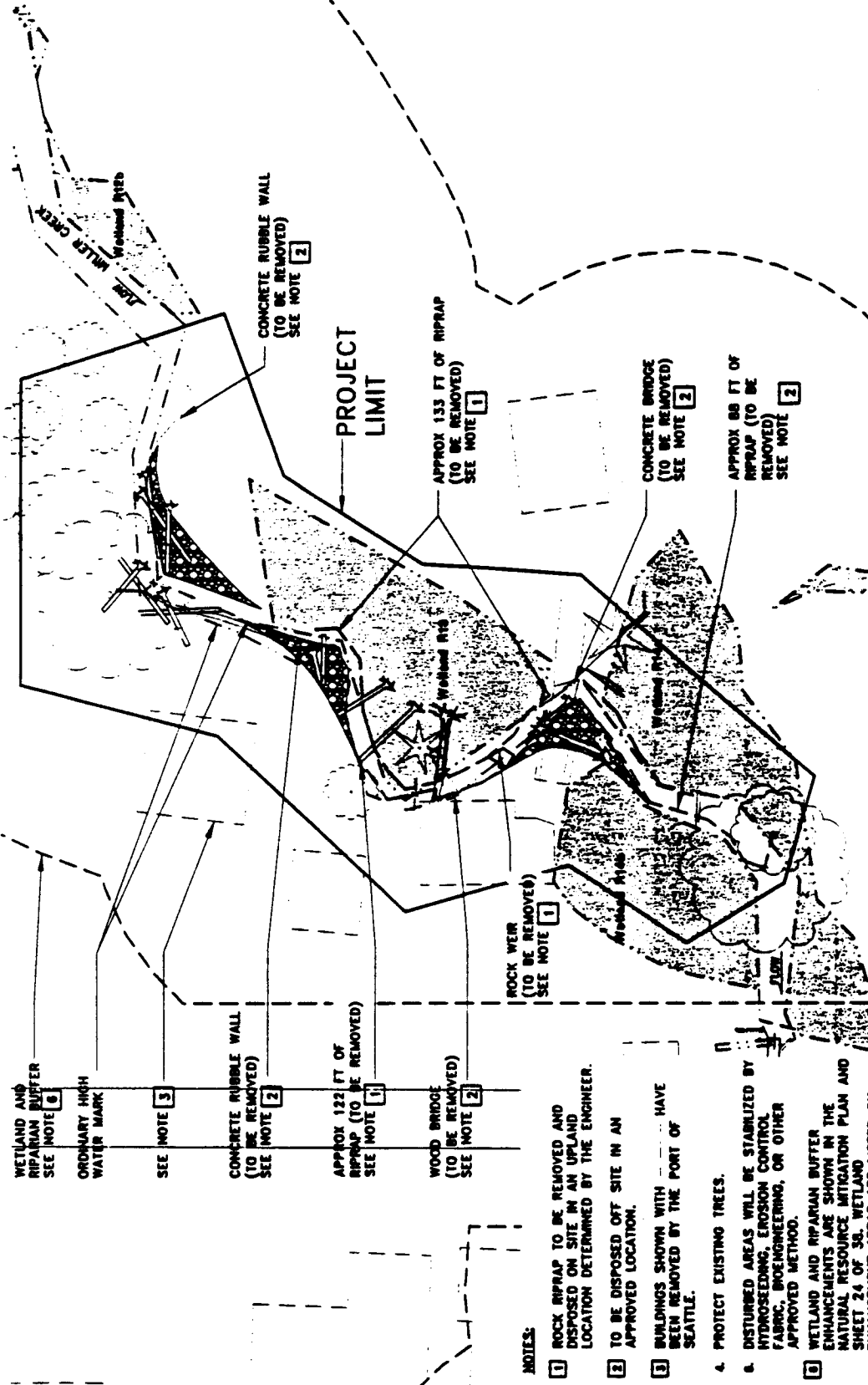
WETLAND

 MILLER CREEK CHANNEL

 GRAVEL BAR

SCALE IN FEET

Parametrix, Inc.



WETLAND AND RIPARIAN BUFFER SEE NOTE 6

ORDINARY HIGH WATER MARK

SEE NOTE 3

CONCRETE RUBBLE WALL (TO BE REMOVED) SEE NOTE 2

APPROX 122 FT OF RIPRAP (TO BE REMOVED) SEE NOTE 1

WOOD BRIDGE (TO BE REMOVED) SEE NOTE 2

ROCK WEIR (TO BE REMOVED) SEE NOTE 1

CONCRETE BRIDGE (TO BE REMOVED) SEE NOTE 2

APPROX 88 FT OF RIPRAP (TO BE REMOVED) SEE NOTE 2

- NOTES:**
- 1 ROCK RIPRAP TO BE REMOVED AND DISPOSED ON SITE IN AN UPLAND LOCATION DETERMINED BY THE ENGINEER.
 - 2 TO BE DISPOSED OFF SITE IN AN APPROVED LOCATION.
 - 3 BUILDINGS SHOWN WITH --- HAVE BEEN REMOVED BY THE PORT OF SEATTLE.
 4. PROTECT EXISTING TREES.
 6. DISTURBED AREAS WILL BE STABILIZED BY HYDROSEEDING, EROSION CONTROL FABRIC, BIOENGINEERING, OR OTHER APPROVED METHOD.
 - 6 WETLAND AND RIPARIAN BUFFER ENHANCEMENTS ARE SHOWN IN THE NATURAL RESOURCE MITIGATION PLAN AND SHEET 24 OF 30. WETLAND ENHANCEMENT AREAS ARE LISTED ON SHEET 9 OF 30.

FILE: 201203 5.2-11
DATE: 11/26/00

- WETLAND
- MILLER CREEK CHANNEL
- GRAVEL BAR



**Figure 5.2-11
Instream Project 4
Proposed Conditions**

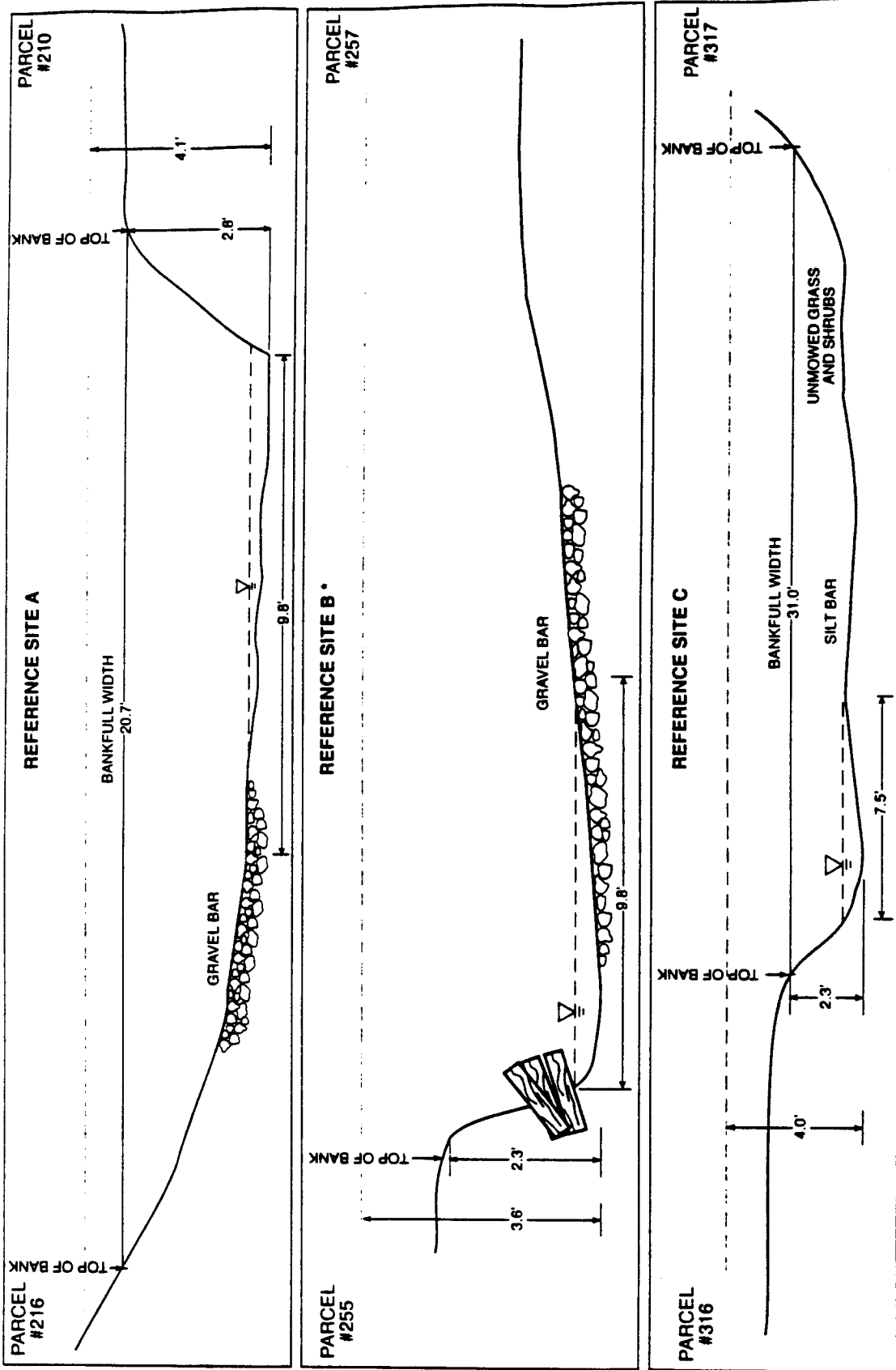


Figure 5.2-12
Representative Cross Sections of Miller Creek
Reference Sites (Surveyed at Parcels 210, 216, 255, 257, 316, and 317)

--- FEMA - 100 year floodplain in elevation
 - - - Water surface elevation at winter base flow (4/28/99)
 * Bankfull width not determined for reference site B
 NOT TO SCALE

Instream Enhancement Project 1

Activities at Instream Project 1 will enhance approximately 470 ft of Miller Creek and 300 ft of a side channel extending from the Miller Creek relocation and Vacca Farm project to the downstream side of the existing South 156th Street bridge (see Figures 5.2-1 through 5.2-8). The primary goal of the enhancement features is to create a geomorphically stable, low-gradient stream. Other goals include increasing the frequency of overbank flow for sediment deposition, enhancing instream habitat, and enhancing the side channel.

Project 1 includes removing riprap, footbridges, railroad ties, and fences along Miller Creek and placing woody debris in the channel to increase instream habitat complexity (see Figure 5.2-8; Appendix B, Sheet C3). Riprap currently located upstream of the South 156th Street bridge will be removed as part of the bridge replacement project. Portions of the area may be regraded to match grading associated with the Vacca Farm project and to promote flooding near the confluence with the side channel. The reach currently located under the existing bridge will be restored by adding some wood and large rocks, providing erosion control along the banks, and replanting the riparian area once this bridge has been replaced.

Addition of woody debris and native vegetation will create more diverse instream habitat for fish and other aquatic organisms. Native riparian and wetland vegetation will be planted along the banks. The side channel will be enhanced by adding woody debris and planting native vegetation adjacent to the banks.

The entire project site is easily accessible to people and heavy equipment on both banks. Therefore, construction of instream enhancement features and replanting of riparian vegetation would be unrestricted. Specific access routes will be identified in the field to protect sensitive areas located within the project boundary.

Instream Enhancement Project 2

Proposed enhancements at Instream Project 2 include removing riprap and the two instream weirs, placing large woody debris and river boulders in the channel, and replanting with native wetland and riparian vegetation (see Figure 5.2-9; Appendix B, Sheet C4). The goal of this project is to improve fish passage and enhance instream and riparian habitat along approximately 234 ft of Miller Creek. Approximately 100 ft of the channel profile will be regraded to match average upstream and downstream gradients.

Approximately 55 ft of riprap will be removed along the left bank between the two weirs and approximately 12 ft of riprap will be removed along the right bank. All of the riprap associated with the two weirs, as well as the two weirs, will be removed from the stream. Two footbridges will also be removed. Coir logs and coir lifts will be used to restabilize areas where riprap is removed (Appendix B, Sheets C4 and C9). Stream gravel will be placed in the channel and large woody debris and river boulders will be used to stabilize the regraded reach. Native wetland and riparian vegetation will be planted to provide shade and reduce bank erosion.

A temporary diversion of Miller Creek and dewatering of an approximately 120-ft section will be required to remove the instream weirs and install new grade controls in the channel (Appendix B, Sheet TE2). Diversion and dewatering are necessary to prevent sedimentation impacts to

downstream portions of the stream during removal of the weirs. Diversion of the stream and construction steps to remove weirs will be implemented only during low-flow conditions and will be consistent with conditions of the HPA permit for the project.

Measures to protect fish (e.g., trapping and relocating fish) in the section of the stream to be dewatered will be implemented prior to diverting flows and will be conducted by a qualified fish biologist consistent with conditions of the HPA permit. To divert the stream, the section of stream to be dewatered would be temporarily blocked with silt curtains, fish trapped and relocated, and the water diverted via a temporary dam, pumps, and pipes. The project area will then be dewatered, weirs and riprap removed and new grade controls installed, banks stabilized, and the stream diverted back into the project area. If necessary, the initial portions of the re-introduced flow would be captured downstream of the project area and pumped into upland areas for biofiltration prior to discharging back into Miller Creek. Diversion of the stream will be conducted only during the work hours when the weirs are being removed (i.e., one or two work days). At the end of each work day, work will be complete enough to allow water to be diverted back into the existing channel.

Instream Enhancement Project 3

Major factors degrading the stream along this reach are erosion and downcutting upstream of a riprapped meander located approximately 300 ft downstream of the South 160th Street culvert. The primary goals of the enhancement are to remove constrictions that channelize flow (i.e., instream tire retaining walls) and stabilize the profile of Miller Creek. Other goals at this site include adding erosion control features along the banks, replanting native riparian and wetland species, removing riprap along both banks, removing a fence along the left bank, and enhancing instream habitat (see Figure 5.2-10; Appendix B, Sheet C5).

All instream tires will be removed throughout this reach, including tires along the left bank immediately downstream of the South 160th Street culvert and those that currently provide erosion control on the right bank upstream of the meander. Erosion control measures and replanting of native vegetation will be used to stabilize the banks where they have been disturbed during construction activities. Upstream of the riprapped meander, the banks will be regraded to create a high-flow channel and two gravel bars (see Figure 5.2-10; Appendix B, Sheet C5). Large woody debris and river boulders will be used to stabilize the channel and reduce velocities. Large woody debris and boulders will also enhance instream habitat. The removal of riprap will allow the stream to naturally meander. The high-flow benches will be planted with native vegetation. Non-native and invasive species will be replaced at the site with native riparian species.

Instream Enhancement Project 4

Gravel bar enhancement features are included in Project 4 (see Figure 5.2-11; Appendix B, Sheet C6). The primary goal of this project is to reduce channel constrictions, which are causing bank erosion and scour, and enhance existing instream and riparian habitat. Two rock walls along the left and right streambanks, as well as an existing driveway, will be removed. Removal of the rock walls and driveway will restore natural channel geomorphology in this reach. Erosion control measures (e.g., sediment fencing and straw bales, erosion control fabric) will be used along the banks if needed. Large woody debris will be placed in the channel and on the gravel bars to maintain the existing channel grade, reduce erosion, and enhance instream habitat.

Removal of the two concrete rubble walls in the downstream reaches will enhance stream morphology and create more diverse instream habitat with pools and bars. It will also require erosion control along the banks; placement of woody debris will be used to stabilize gravel bars and promote deposition of suspended sediment.

Native riparian vegetation and wetland vegetation will be planted along the right bank within the project area and along the left bank where the site is accessible. The planted vegetation will provide shade and bank stability, as well as structural and species diversity to the riparian understory and forest. Invasive and non-native species will be removed from the site.

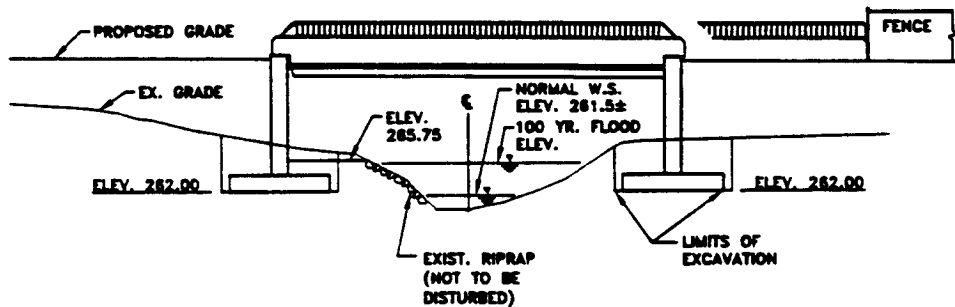
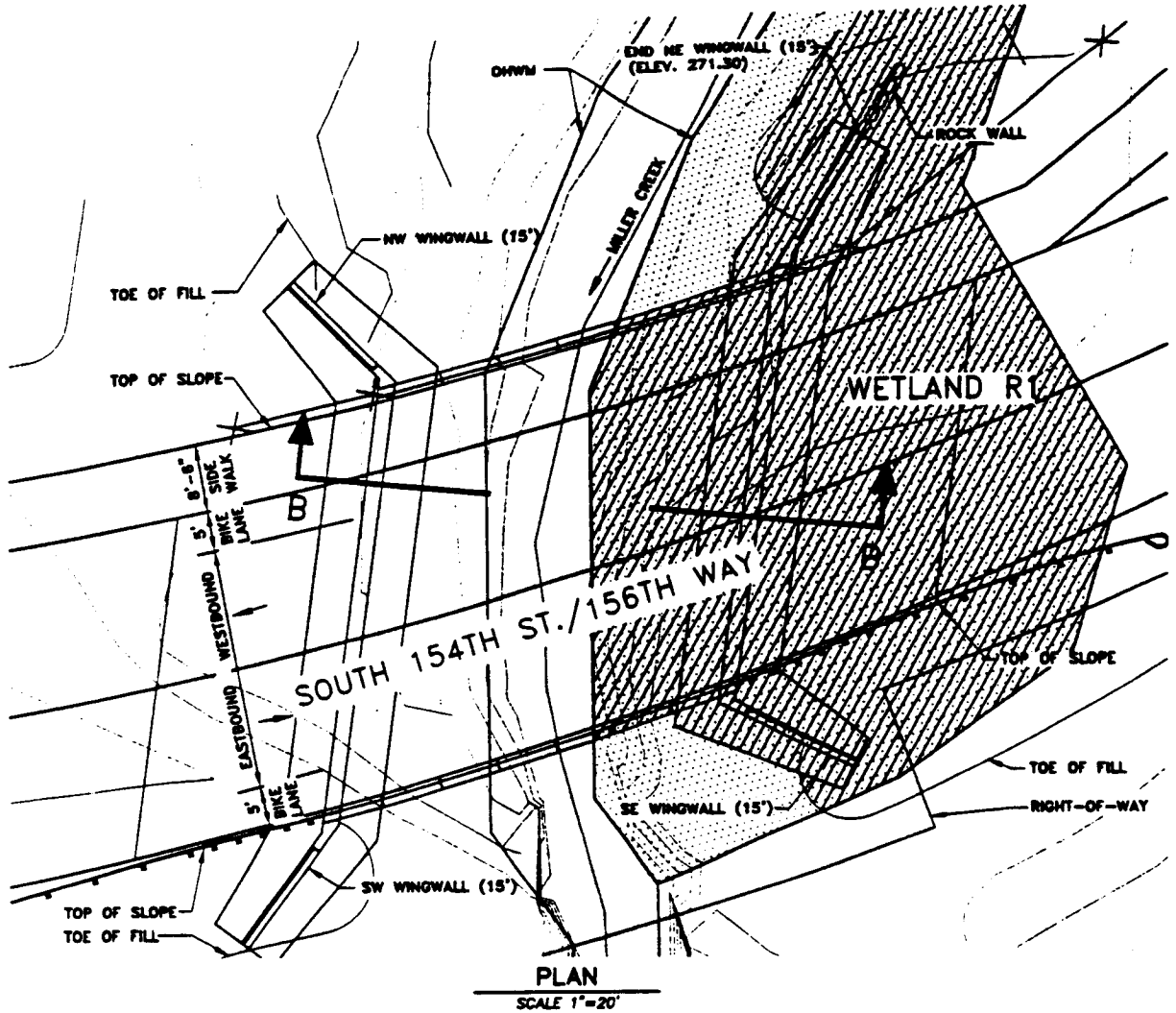
General Instream Habitat Enhancement

Large woody debris placement will generally conform to existing WDFW guidelines and be consistent with conditions of the HPA permit. The species (western redcedar, Douglas fir, and western hemlock [*Tsuga heterophylla*]) and size will be determined during the final design. The number and location of woody debris at each project site is shown on the detailed plan sheets in Appendix B (Sheets C3 through C6), and large woody debris will be field-placed by the project engineer or habitat biologist during construction. Large woody debris will be designed to be stable in the stream. Natural anchoring methods, such as partially burying or locating the woody debris outside the low-flow channel, will be preferred over conventional anchoring methods (Appendix B, Sheet C10). The general locations of large woody debris will vary from site to site, depending on the design objective. Much of the woody debris can be salvaged from existing forested areas on the MPU project site that will be filled by embankment construction. This salvage woody debris will have root wads attached.

South 154th Street/156th Way Bridge Relocation

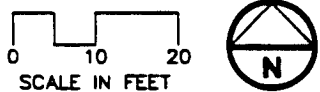
To accommodate the RSAs for the third runway, it will be necessary to relocate South 154th Street north and west of its current alignment. The existing and proposed alignment of South 154th Street connects with South 156th Way. As a result of relocating this roadway, it will be necessary to replace and relocate the existing bridge over Miller Creek at South 156th Way. The existing timber bridge will be removed and replaced with a new bridge that will span the 100-year floodplain of the stream (see Figure 5.2-1; Appendix B, Sheets L1, L1.1, P1, and P2).

Elements of this bridge relocation will require restoring the streambanks after the existing timber bridge is removed. The existing stream channel under the bridge is armored with riprap and confined by the timber walls of the bridge. As a result of construction for the timber bridge, this segment of the stream was widened, and the channel bed here is wider than the segments to the north and south. After removing the bridge, restoration activities will focus on re-establishing the streambanks. To accomplish this, a portion of the channel will be filled to restore the natural channel width (Figure 5.2-13; Appendix B, Sheet P1). Loose riprap will remain along the edge of the stream channel under the bridge segments only to provide stabilization under the bridge (see Figure 5.2-13; Appendix B, Sheets P1 and P2). Streambanks will be planted with native riparian vegetation (Table 5.2.8).



NOTE:
ALL DISTURBED AREAS WILL BE STABILIZED USING APPROPRIATE BMPs.

FILE 291203_5.2-13.dwg
DATE 11/28/00



LEGEND

	WETLAND R1
	WETLAND IMPACTS

Figure 5.2-13
South 156th Way
Bridge Relocation

Table S.2-8. Final performance standards, evaluation approach, and contingency measures for instream habitat enhancements in Miller Creek.

Design Criteria	Performance Standard	Evaluation Approach	Contingency Measures ¹
Remove cemented riprap along banks, encourage natural formation of meander bends and cut benches.	Channel reach in project area is free of man-made debris that could affect water quality (e.g., tires, metal debris). Channel armoring, walls, and riprap are removed from the channel in each project reach per design specifications.	Record drawings to verify removal of riprap and other in-channel structures consistent with design. Baseline monitoring to establish as-built number and type of habitat features (pools and riffles).	Remove riprap or other structure consistent with design. Add LWD to create additional channel complexity and promote formation of pools and riffles.
Increase the amount of geomorphically stable large woody debris in the channel.	Number of large woody debris features in stream remains stable or increases compared to baseline (as-built) conditions.	Record survey and visual inspection of channel	Add LWD to create additional channel complexity.
Stabilize those areas of excessive erosion by using native vegetation and large woody debris.	Number and density of habitat features (e.g., pools, riffles, bars, undercut banks) remain stable or increase compared to baseline (as-built) conditions. Streambank vegetation in enhancement areas provides at least 50% cover on channel banks.	Record survey and visual inspections. Measure density and number of habitat features Site inspections and record drawings.	Add LWD to create additional channel complexity and promote formation of pools and riffles. Repair damaged bank if necessary. Stabilize banks with bioengineering, planting live stakes, or seeding.
Remove all trash from the channel that could be harmful to fish habitat, and water quality.	No evidence of bank erosion (for example rill, surface scour, or sediment deposition) is present, above the OHWM. Channel reaches in project area are free of debris (e.g., tires, metal debris, wire, pipe, etc.).	Site inspections.	Clear any remaining trash in the buffer.
Add gravel to degraded reaches where natural recruitment is limited.	Substrate is predominantly gravel on bars and benches.	Assess substrate composition with pebble counts. Visual inspection	Evaluate source of sediment and remove/control. Add channel features (e.g., large wood, and boulders) to reduce bedload movement. Repair damaged bank if necessary. Stabilize banks with bioengineering, planting live stakes, seeding, or erosion control material.
Reduce erosion by vegetating banks and replanting the Vacca Farm site.	No evidence of surface erosion in newly planted stream buffers.	Site inspections.	Repair damaged bank if necessary. Stabilize banks with bioengineering, planting live stakes, seeding, or erosion control material.

¹ For all performance standards, monitoring periods may be extended if performance standards are not met.

5.2.2.8 Monitoring and Performance Standards

The monitoring approach, methods, schedules, and reporting for the instream habitat projects will be consistent with the approach outlined for all MPU mitigation projects (Chapter 4). Specific performance standards developed for the instream projects will be evaluated to ensure that the projects are meeting overall objectives and goals (Table 5.2-9).

Table 5.2-9. Monitoring schedule for the instream enhancement projects.

Feature	Activity	Frequency	Data Collection Year										
			0	1	2	3	4	5	6	7	8	9	10
Habitat Structures	Inspection, stability of habitat features	Annually (May), or after flows in excess of the 2-year peak flow during the first 3 years	X	X	X	X		X		X		X	X
Substrate	Pebble counts	Semiannually (February/August)	X	X	X	X		X		X		X	X
Erosion or Scouring	visual evidence of erosion or scouring	Annually (May), or after flows in excess of the 2-year peak flow during the first 3 years	X	X	X	X		X		X		X	X
Structures	Evidence of cavitation or scouring	Annually (May), or after flows in excess of the 2-year peak flow during the first 3 years	X	X	X	X		X		X		X	X
Adverse Flooding	Inspect channel banks and riparian zone for ponded water	Twice yearly (February/November)	X	X	X	X		X		X		X	X

Instream Habitat Conditions

Instream habitat will be monitored and evaluated against performance standards to ensure that these features provide the desired habitat and bank stabilization functions, and that instream large woody debris is stable, creating pools and meanders as designed. Table 5.2-8 lists specific performance standards, methods/parameters, and contingency measures for ensuring that the instream enhancements are meeting project goals and objectives. Monitoring for instream habitat enhancement projects will focus primarily on evaluating parameters related to aquatic habitat quality such as habitat complexity (e.g., pool/riffle morphology, undercut banks), habitat features (e.g., large woody debris, gravel bars), and overall stream condition (e.g., lack of sedimentation or erosion, lack of man-made debris).

Monitoring methods and schedule for the instream enhancement projects are listed in Table 5.2-9. The schedule includes routine inspections and emergency inspections to be conducted following major flood events.

Biological Conditions

The instream enhancement projects are designed to enhance biological as well as physical functions in Miller Creek and therefore, as part of the monitoring program for the Miller Creek instream projects, biological conditions will be evaluated and compared to existing or baseline conditions in the stream. Biological conditions will be assessed using the benthic index of biotic integrity (BIBI) (Kerans and Karr 1994; Fore et al. 1995; Kleindl 1995). Aquatic invertebrate populations will be sampled from representative riffles in Miller Creek, and the data will be analyzed to determine the BIBI score. The BIBI score integrates several physical and chemical conditions in the stream and watershed.⁷

Information gathered from this study will be used to evaluate changes in the invertebrate assemblages and relate them to other monitoring parameters and changes at the mitigation sites through the monitoring period. The BIBI scores obtained each year during the monitoring period will be compared to baseline values obtained from Miller Creek prior to mitigation, as well as to values obtained in other urban streams in the Puget Sound region. Since this methodology has not been widely applied to mitigation, BIBI data will be used to generally assess how the mitigation projects affect biotic integrity, but will not be linked to performance standards.

Vegetation

Riparian and channel vegetation installed as part of the instream projects will be monitored and evaluated against the performance standards for the wetland and riparian buffer plantings described in Table 5.2-3. Monitoring methods and schedule for evaluating riparian vegetation at the instream projects are listed in Table 5.2-4.

5.2.2.9 Maintenance and Contingency Plans

Routine maintenance and contingency measures will be implemented consistent with the approach described in Chapter 4. A design goal for the instream enhancement features is that each enhanced reach function as a natural channel, requiring little or no maintenance. As indicated in Tables 5.2-8 and 5.2-9, periodic maintenance may be required to correct a variety of detrimental conditions to ensure that the projects meet performance standards.

In the event that contingency measures are necessary, the Port will use an adaptive management plan, as outlined in Chapter 4, to assess factors contributing to poor performance and design appropriate measures to change the contributing factors. Specific contingency measures for each of the performance standards for the instream projects are listed in Table 5.2-8.

All of the proposed enhancement projects have similar basic criteria for performance standards: (1) maintain minimum flow depths and velocities for fish passage, water quality, and sedimentation; (2)

⁷ The BIBI is a numerical analysis of stream invertebrate data that is used to assess the degree to which macroinvertebrate populations have been altered by human disturbance. A strong correlation between levels of urbanization and BIBI scores exists (Fore et al. 1996; Horner et al. 1996). While BIBI measurements will monitor changes in the invertebrate assemblages in the stream, the values will also reflect activities in the watershed upstream of the mitigation, and thus cannot be used to unequivocally determine the effect of mitigation actions.

provide capacity for peak flows; and (3) reduce erosion of the bed and banks. The enhancement features were designed to meet these criteria; however, if flow rates and stream hydraulics differ substantially from the design flows used to develop the enhancement features, these features may not function as designed. If this occurs, reaches with enhancement features can be modified by:

- Modifying channel widths to reduce velocities and improve capacity.
- Adding additional bank stabilization and erosion control methods.
- Adding or modifying channel profile structures (e.g., log weirs) to reduce velocities.

5.2.2.10 Implementation of Buffer and Instream Enhancement Projects

Implementation of the buffer and instream projects along Miller Creek will be coordinated with each other, and will be constructed in a manner consistent with federal, state, and local permits (e.g., CWA 404, HPA). In addition, construction of the mitigation projects will be coordinated with construction of the third runway embankment, security roads, utility relocations, South 156th Street bridge relocation, and stormwater management facilities to ensure that implementation of the mitigation projects is not impacted by other construction activities. A proposed implementation time line is resented in Table 5.2-10. Details regarding implementation steps, construction methods, and sequencing are included in this section.

General Construction Sequencing

Landscape work for the buffer enhancement will be coordinated with the instream enhancement projects (Section 5.2.2). Wetland and riparian enhancements will start with installation of TESC measures, demolition of existing structures (e.g., buildings, driveways, fences), clearing and grubbing the site to remove non-native vegetation, and preparing the site for planting. Temporary irrigation may be installed for some enhancement areas if necessary. Wetland and riparian vegetation will be planted in the fall immediately following site preparation (Appendix B, Sheets L1 through L6). BMPs for sediment and erosion control during these activities will minimize impacts to the stream and adjacent wetlands (Appendix B, Sheets TE1 through TE5). Measures include placing silt fence around work areas and staging areas, and placing straw bales at key locations within the project limits. Clearing and brush removal will be limited to only those work areas that the contractor is scheduled to begin within the following 2 weeks. The disturbed areas will be stabilized immediately after work in that area is completed. TESC measures will remain in place and be maintained until the entire site has stabilized.

Instream work will be scheduled during dry weather, when base flows are at a minimum, and will be restricted to allowable work times consistent with the HPA (i.e., July 15 to September 15). Prior to the start of any other construction activities, the TESC plan for the instream projects will be implemented and the TESC elements will be in place (Appendix B, Sheets TE1 through TE5). Once the temporary facilities are in place, the contractor will implement a plan for controlling water in areas requiring instream work. This may include excavating dewatering trenches, French drains, and sumps.

Table S.2-10. Proposed Implementation Timeline for Miller Creek In-Stream, Wetland, and Riparian Buffer Enhancements Projects

Project/Activity	Year (Year One Starts with the First Construction Season After the Date Permits Are Issued)																							
	Year 1				Year 2				Year 3															
	J	F	M	A	M	J	J	A	S	O	N	D	J	F	M	A	M	J	J	A	S	O	N	D
Miller Creek In-Stream Enhancements																								
Preconstruction meeting																								
TESC, Site Preparation																								
Install silt curtains and silt fencing																								
Clear site and grade per plan																								
Remove bridges, channel rip-rap or other structure per plan																								
Install LWD, stream gravel, bioengineering																								
Hydroseed/implement planting plan																								
Remove silt curtain and TESC measures																								
Produce record drawings, conduct baseline monitoring																								
Begin compliance monitoring																								
Wetland and Riparian Buffer Enhancements																								
Preconstruction meeting																								
TESC, Site Preparation																								
Remove debris and structures per plan																								
Remove non-native plants per plan																								
Install plants per planting plan																								
Produce record drawings																								
Conduct baseline monitoring																								
Begin maintenance and compliance monitoring																								

1 Plant procurement for all projects will be implemented six to twelve months prior to the anticipated planting date to ensure that plants in the specified quantities and species are available by the scheduled planting date. Implementing mitigation projects may vary from this proposed schedule depending upon coordination with other MPU projects and contract obligations.

Temporary berms (using sandbags or other structures that would not be driven into the channel) may be used to divert flows around bank work. Silt curtains will be installed prior to any LWD placement except for channel spanning LWD (Appendix B, Sheet TE5). Silt curtains would extend completely around the project site. Any turbid water inside the silt curtain would be pumped out and directed through settling ponds and straw bale filters prior to being discharged back into the stream. All instream work will be performed in a manner to protect fish and other aquatic organisms, consistent with the HPA permit conditions.

Large woody debris will be anchored without the use of cables or ecology blocks by excavation and partial burial (Appendix B, Sheet C10). Placement and excavation for LWD will be accomplished by hand tools or from the streambank using equipment with extendable arms (e.g., backhoe). No equipment will be allowed to drive into or cross the stream channel. Access to project sites will avoid wetlands where possible. If access through non-wetland areas is infeasible, protective plywood mats will be placed over access paths and work areas to protect wetlands and the stream. Silt fences will be installed along all access routes. Vegetation clearing will be limited, and vegetation will be mowed rather than removed wherever possible to gain access to project sites. Access routes will be stabilized and revegetated immediately following construction.

Plant material used in the mitigation will be obtained from commercial nurseries. Nurseries will be required to certify that the plant material is legally procured and from the appropriate geographic source. The appropriate geographic source for plant material used in the mitigation is defined as the area that is bounded on the north by the Fraser River Valley, British Columbia; on the east by the 1,000-foot elevation of the Cascades; on the west by the 1,000-foot elevation in the Olympic or Coast ranges; and on the south by the Willamette Valley.

Construction Steps

Construction steps required to implement the instream and buffer enhancement projects are provided below. General construction steps, as well as construction steps for each of the four instream projects and placement of large woody debris in the stream within the project area, are included.

General Conditions

- On award of the contract, the contractor will provide the Port with any required pre-construction submittals, work plans, and schedules.
- A pre-construction meeting will be held with the contractor, architect/engineer, and wetland scientist to review submittals, work plans, schedules, and permit conditions.
- The contractor will be responsible for ensuring that the work is performed in compliance with all permit conditions and shall maintain a copy of permits on-site.
- Work will be coordinated to avoid re-entry and damage to areas that have previously been planted; work will be conducted so that no other work will impact completed landscape work.
- Areas where any landscape work has been completed will be off-limits to all vehicular traffic, and pedestrian traffic will be strictly limited.

- Construction will take place during the dry season; any instream work or work below the OHWM will take place only during the allowable work times, consistent with HPA permit conditions (i.e., July 15 to September 15).
- Plant procurement shall be coordinated with the grading schedules, and irrigation installation if necessary, and be secured 6 to 12 months prior to the scheduled planting season to ensure that plants are available in the quantities and species required by the planting plan.

Site Preparation

- Establish vertical and horizontal site controls and maintain through construction to record drawings.
- Identify and flag limits of work for mitigation site.
- Identify staging areas and temporary access/haul roads.
- Implement TESC plan and install TESC measures.
- Install fencing (orange barrier) around areas to be protected (e.g., stream channel, existing wetlands, vegetation/trees to be retained).
- Maintain security of the site through construction.
- Establish temporary access/haul roads.
- Establish staging and stockpile areas.
- Implement a spill control plan and identify fueling areas.

Clearing, Excavation, and Grading

- Clear and grub portions of the site as specified; clear structures and impervious surfaces and existing non-native vegetation in selected areas.
- In selected areas, grade per specifications.
- Install irrigation as specified in selected areas.

Instream Project 1 (Appendix B, Sheets C3, C9, C10, and TE1)

- Install silt curtains and silt fencing per specifications. This can be done in phases as approved by the engineer.
- Remove riprap, footbridges, railroad ties, and fences identified on plan sheet.
- Regrade portions of the area as needed to meet grading from Vacca Farm projects.
- Install LWD in the main channel and side channel.
- Implement planting plan for the main channel and side channel.
- Seed disturbed areas (including any access roads and staging areas).
- Maintain TESC measures adjacent to restored stream bank until adjacent riparian buffer has been planted and stabilized.

- Remove silt curtain and TESC measures once the site is stabilized and approved by the engineer and wetland scientist.

Instream Project 2 (Appendix B, Sheets C4, C8 through C10, TE2)

- Install silt curtains and silt fencing per specifications.
- Clear and grade the minimum area required for construction of the project.
- Remove two footbridges identified on plan sheet.
- Remove riprap associated with two weirs; remove the two weirs.
- Install coir logs and coir lifts to stabilize areas where riprap is removed.
- Install LWD, river boulders, and stream gravel.
- Seed disturbed areas.
- Implement planting plan for stream banks, wetland, and riparian areas adjacent to project site.
- Remove silt curtain and TESC measures once the site is stabilized and approved by the engineer and wetland scientist.

Instream Project 3 (Appendix B, Sheets C5, C8 through C10, TE3)

- Install silt curtains and silt fencing per specifications.
- Clear and grade the minimum area required for construction of the project.
- Remove instream tires lining left and right banks; remove riprap.
- Construct high-flow benches and gravel bars.
- Install LWD, river boulders, and stream gravel.
- Install coir lifts, coir logs and plant banks with live stakes to stabilize new banks.
- Seed disturbed areas.
- Implement planting plan for channel banks, wetland, and riparian areas adjacent to the project site.
- Remove silt curtain and TESC measures once the site is stabilized and approved by the engineer and wetland scientist.

Instream Project 4 (Appendix B, Sheets C6, C8 through C10, TE4)

- Install silt curtains and silt fencing per specifications.
- Clear and grade the minimum area required for construction of the project.
- Remove riprap rock walls and existing driveway.
- Construct three high-flow benches and gravel bars; construct new channel banks.
- Install LWD, river boulders, and stream gravel.
- Place geotextile over new banks.

- Seed disturbed areas.
- Implement planting plan for new channel banks, wetland, and riparian areas adjacent to the project site.
- Remove silt curtain and TESC measures on the east bank once the site is stabilized and approved by the engineer and wetland scientist.

Closeout

- Complete site cleanup by removing temporary haul/access roads and staging areas.
- Remove construction equipment and debris.
- Hydroseed and/or install plants in any temporary staging areas or access roads within the mitigation site boundaries.
- Hydroseed erosion control mix in temporary staging areas/access roads outside the mitigation boundaries.
- Install permanent fence and/or signs along buffer boundary.

Record Drawings, Monitoring, and Maintenance

- Produce grading record drawings (i.e., 'as-builts') for instream enhancement projects and planting plan record drawings for wetland and buffer enhancement areas.
- Complete a baseline report, including record drawings, buffer boundaries along Miller Creek, and final monitoring plan (e.g., locations of monitoring plots, baseline conditions).
- Begin compliance monitoring during the first growing season after planting is complete. Submit annual monitoring reports for the 10-year monitoring period.
- Conduct maintenance (e.g., weed management, WHMP) and implement any necessary contingency measures to meet performance standards.

5.2.3 Drainage Channel Replacement Plan

Three small intermittent drainage channels (Waters or Drainage Channels A, B, and W) are located in the acquisition area on the west side of the existing runway (see Chapter 2, Figure 2.1-2).⁸ These drainage channels currently convey water (groundwater and surface water) from the hillside on the western edge of the airport to Miller Creek and the wetlands adjacent to Miller Creek. Channel A is located immediately east of 12th Avenue South in a roadside drainage ditch. Channel B originates in Wetland 37f and is located west of 12th Avenue. Channel B provides a surface water connection between Wetland 37f and Wetland R9. Channel W is located east of the existing perimeter road within the current Airport Operation Area (AOA). This channel originates in Wetland 20b and flows northwest through a culvert and under the perimeter road; it ultimately empties into Channel A.

⁸ A ditch on the Vacca Farm (see Section 3.4) is not included in this mitigation because its functions are enhanced as part of the Vacca Farm Restoration Projects (see Section 5.1).

Approximately 1,290 linear ft of existing drainage channels will be filled as a result of third runway construction (Chapter 3). The Port proposes to mitigate for filling these channels by replacing and restoring their functions on-site. A subsurface drainage system in the fill embankment will collect water infiltrating the embankment and direct this water to surface water channels at the base of the embankment. Water from the replacement drainage channels will be directed to riparian wetlands along Miller Creek (Figure 5.2-14). The surface water channels will be designed to replace the 100-year flow conveyance capacity of the channel lengths being filled. Replacement drainage channels will be permanent features and their construction will be coordinated with the Miller Creek buffer enhancement projects, embankment construction activities, and stormwater facility construction.

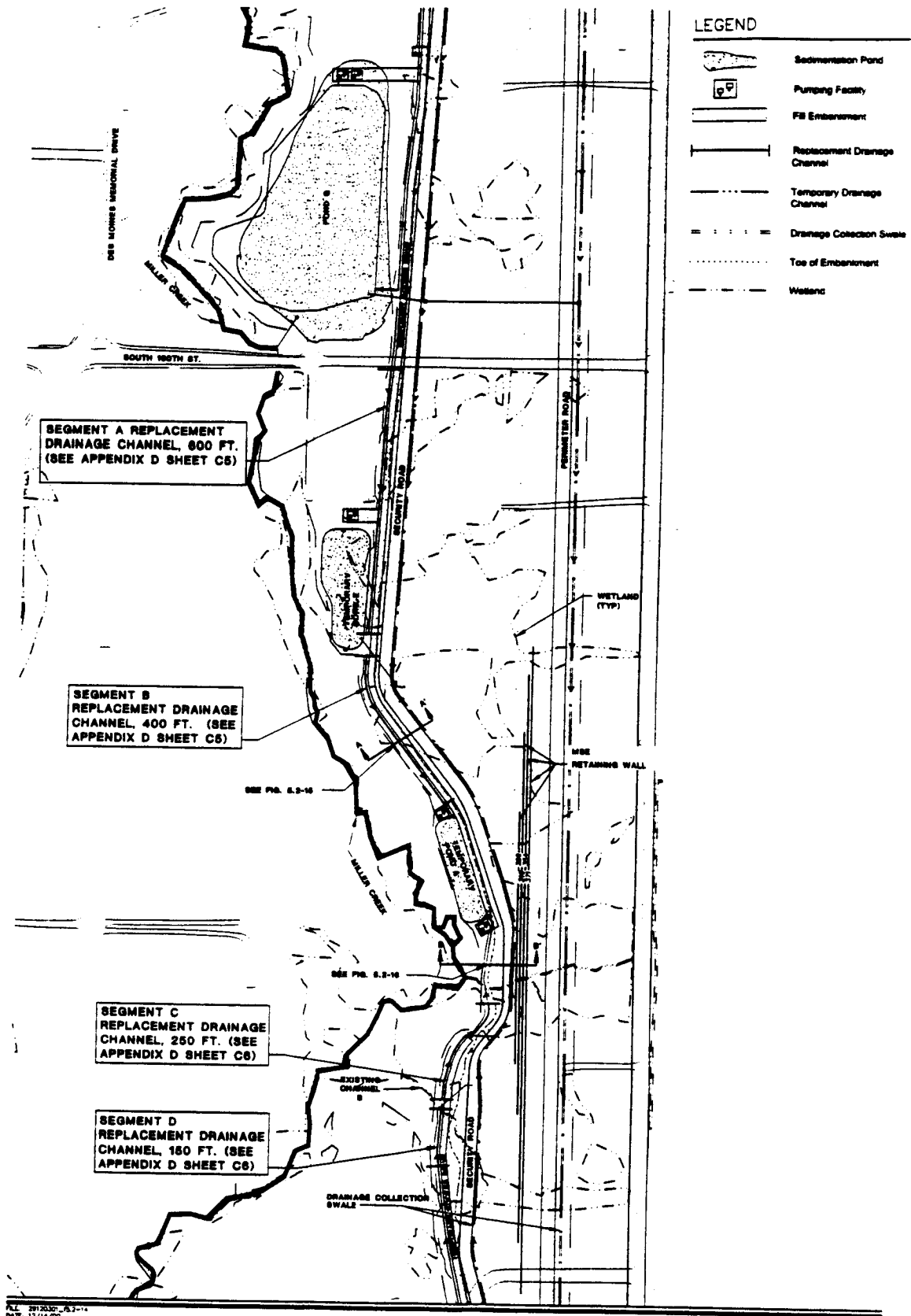
5.2.3.1 Goals, Objectives, and Design Criteria

To replace the functions of existing channels, four replacement drainage channel areas will be designed along the west side of the perimeter roadway at the base of the fill embankment. The goals of this mitigation action are listed below and described in Table 5.2-11.

- The replacement drainage channels will provide adequate flow (100-year flow) conveyance functions.
- The replacement drainage channels will collect seepage from the embankment to maintain base flows in Miller Creek and hydrology of down slope wetlands.
- The replacement drainage channels will provide open channel lengths equivalent to the existing drainage channels lengths.
- The replacement drainage channels will be planted with a vegetated buffer to provide shade to enhance water quality in Miller Creek and other wetlands.

Table 5.2-11. Mitigation goals, design objectives, and design criteria for replacement drainage channels.

Design Objectives	Design Criteria
Goal 1: The replacement drainage channels will provide adequate flow conveyance functions (100-year flow)	
Provide channel flow capacity for expected runoff.	Construct the replacement channel to convey the 100-year, 24-hour design storm. Channel depths will be a minimum of 2 ft deep with side slopes of 3:1 or flatter; or if slopes are steeper, log and rock weirs will protect channel banks.
Goal 2: The replacement channel will collect seepage to maintain base flows and wetland hydrology	
Integrate channel into embankment drainage layer so groundwater can be collected.	Construct channel down gradient and hydrologically connected to the drainage layer of the embankment.
Convey water to riparian wetlands down slope from the embankment.	Direct water in drainage channels to discharge points in or adjacent to riparian wetlands along Miller Creek (Wetlands A13, 18, 37, 39, 44a, and A9).
Goal 3: The replacement channels will provide an open channel of equivalent length as the existing channel	
Construct new channels with equivalent length, substrate, and streamside vegetation.	Construct new channels with a minimum length of 1,290 ft. Channel substrate will be stable, and have slopes of less than 3:1. Where steeper channel slopes are required, protect from downcutting with log weirs.
Goal 4: Plant a vegetated buffer along the length of channel to provide shade which will enhance water quality	
Provide a vegetated buffer along the length of the mitigation channel.	Plant native shrubs at greater than 2,100 individuals per acre along channel banks. Plant native trees greater than 280 trees per acre along channel banks.



SEGMENT A
REPLACEMENT DRAINAGE CHANNEL, 800 FT.
(SEE APPENDIX D SHEET C6)

SEGMENT B
REPLACEMENT DRAINAGE CHANNEL, 400 FT.
(SEE APPENDIX D SHEET C6)

SEGMENT C
REPLACEMENT DRAINAGE CHANNEL, 250 FT.
(SEE APPENDIX D SHEET C6)

SEGMENT D
REPLACEMENT DRAINAGE CHANNEL, 150 FT.
(SEE APPENDIX D SHEET C6)

LEGEND





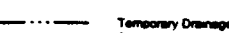



-  Sedimentation Pond
-  Pumping Facility
-  FB Embankment
-  Replacement Drainage Channel
-  Temporary Drainage Channel
-  Drainage Collection Swale
-  Toe of Embankment
-  Wetland

Figure 5.2-14
Location of Replacement Drainage Channel and Swales along the West Side of the Third Runway Embankment

5.2.3.2 Mitigation Site Description

The replacement channels will be located in areas that are currently predominantly residential lawns, upland forest, or emergent wetlands. The replacement drainage channels will be constructed on the west side of the perimeter road that will run immediately west of the new embankment for the third runway (see Figure 5.2-14).

5.2.3.3 Ownership

The Port owns the property where the replacement drainage channels will be relocated.

5.2.3.4 Rationale For Selection

The drainage channel mitigation replaces the water conveyance functions of the channels that will be impacted by the project. Replacement drainage channels will be constructed as close to the original channel location as possible. The existing channels currently convey water from the hillslope to the west of STIA to downgradient wetlands and Miller Creek. The channels are designed to ensure that the discharge of water to wetlands adjacent to Miller Creek continues.

5.2.3.5 Constraints

There are no constraints that affect implementation of the planned mitigation action.

5.2.3.6 Ecological Assessment of the Mitigation Site

The replacement channels will be located in areas that are currently residential, upland forest, or emergent wetlands. A detailed description of ecological conditions at these sites is given in the *Wetland Delineation Report* (Parametrix 2000c).

5.2.3.7 Replacement Drainage Channel Mitigation Design

A permanent drainage collection swale will be constructed at the toe of the embankment to intercept surface water runoff from the embankment, which will be directed to the stormwater facilities. The replacement drainage channels on the west side of the security road will receive water from the underdrain system that will collect water infiltrating into the embankment or from the collection swale at the base of the embankment (see Figure 5.2-14 through 5.2-16; Appendix D, Sheet C3.1). The replacement channels will then direct this water to down slope wetlands.

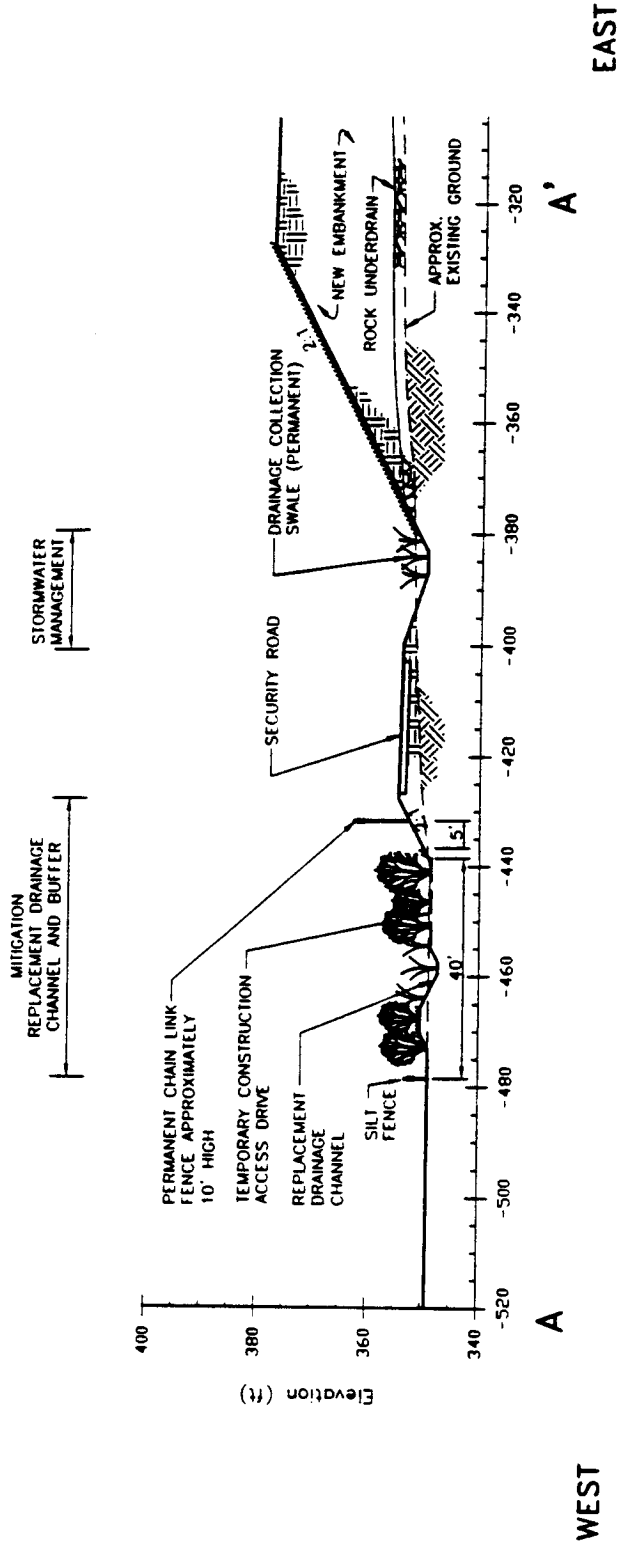


Figure 5.2-15
Cross Section A-A' of the Replacement
Drainage Channel, Drainage Collection
Swale, and Third Runway Embankment

FILE: 21/001/5.2-15
 DATE: 12/17/00

SCALE: HORIZONTAL 1"=30'
 VERTICAL 1"=30'

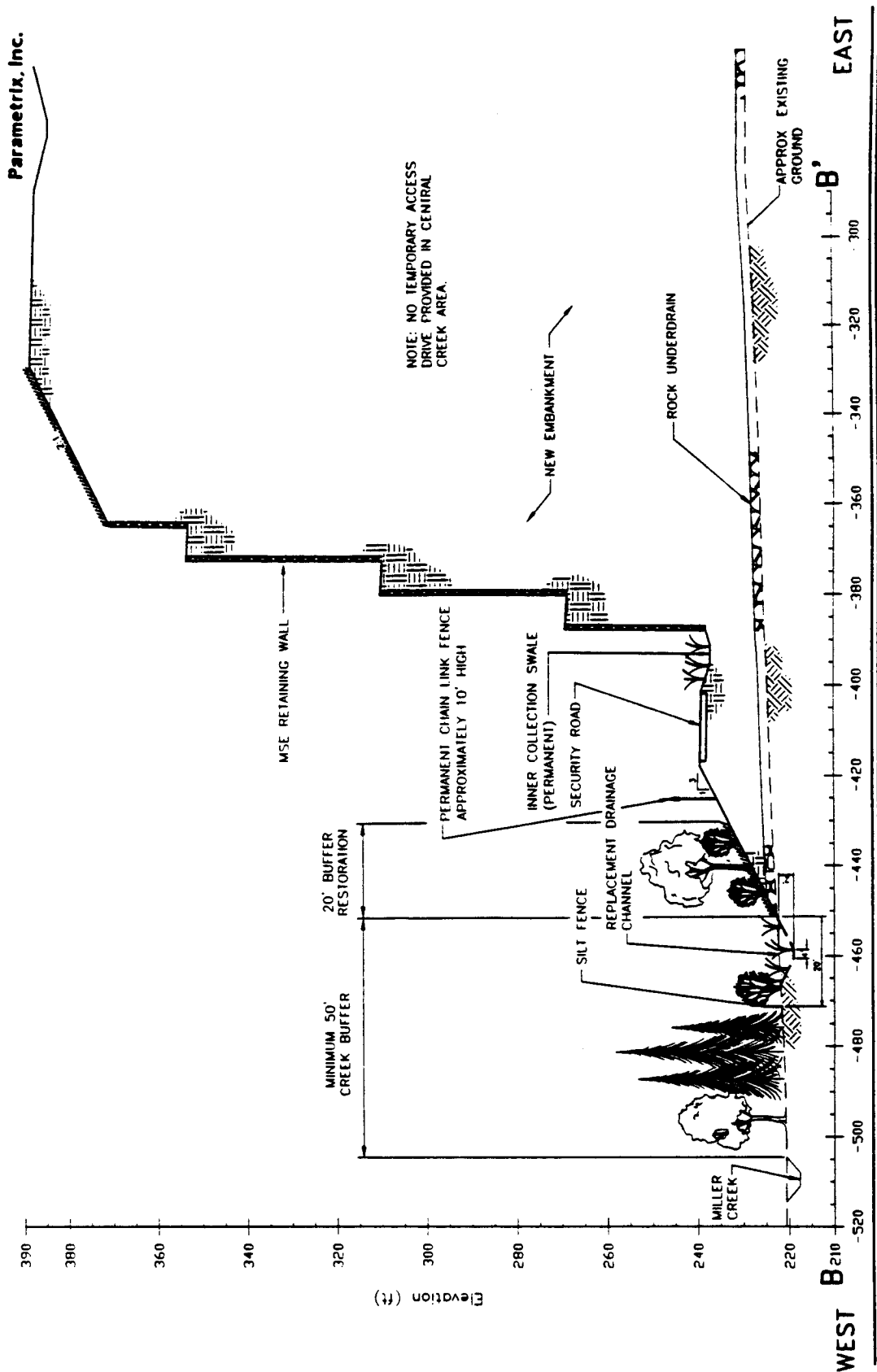


Figure 5.2-16
Cross Section B-B' of the Replacement
Drainage Channel, Drainage Collection
Swale, and Third Runway Retaining Wall

SCALE: HORIZONTAL 1"=30'
 VERTICAL 1"=30'

FILE: 287203_07-18
 DATE: 12/14/00
 SOURCE: FH16

During construction of the embankment and retaining wall west of the third runway, the collection swale will collect construction runoff from the outermost portion of the embankment and route the water to a sedimentation and water treatment facility. After construction of the embankment and retaining walls is complete, the collection swale will be retained to intercept surface water runoff from the embankment and direct it to the replacement drainage channels via culverts under the perimeter road. The replacement drainage channels (a minimum of 1,290 linear ft) will convey groundwater and seepage from the embankment and runoff water to adjacent wetlands (see Figure 5.2-14; Appendix D, Sheet C3, and Sheets C5 through C8).

Channel Size and Slope

The drainage channels will be designed to convey the 100-year peak flow rate. The maximum flow depth in the channel will be determined by anticipated flow conditions; the channel depth will range from 2 to 4 ft with 3:1 side slopes. The bottom width will be controlled by the flow minimum design depth (0.5 ft) and channel slope, but will be a minimum of 3 ft wide. Check dams, log weirs, or channel widening will be used to prevent erosion, sedimentation, scouring, and downstream deposition impacts.

Discharge Points

The drainage channels will discharge into selected wetlands to maintain wetland hydrology and base flows in Miller Creek (i.e., Wetlands A13, 18, 37, 39, 44a, and R9; Appendix D, Sheets C4 through C7). At the discharge points, the channels will be designed to prevent erosion or scouring impacts in the receiving channel or wetlands through the use of dispersal trenches or similar construction. These designs will include installing log weirs and/or bank stabilization (i.e., live stakes, branch packs) at discharge points to prevent erosion.

Groundwater Seepage and Hydrology

Existing channels convey seepage and stormwater to downstream wetlands and Miller Creek. The replacement drainage channels will collect seepage water that discharges from the embankment and distribute it to downslope wetlands using rock berms or infiltration swales. The hydrology of wetlands down slope of the new embankment will be monitored following construction to ensure that wetland hydrology is maintained.

5.2.3.8 Implementation

The replacement drainage channel will be constructed as part of the stormwater facilities for the third runway embankment. Channel construction and planting of the vegetated buffers will be coordinated with construction of the embankment and stormwater facilities, the Miller Creek riparian wetland and buffer enhancements, and temporary restoration of wetland impacts. Implementation of the replacement drainage channel is described in Section 5.2.5.

Landscape Plan

The landscape plan for the replacement channels has been designed to be consistent with the Port's WHMP. The side slopes and buffers along the channels will be planted with native vegetation to provide shade. The vegetation will also contribute organic matter to the drainage channels and ultimately to Miller Creek. The vegetated buffer will extend from the edge of the channel to

approximately 10 ft west of the security road (see Figures 5.2-15 and 5.2-16; Appendix D, Sheets C5 and C8). This distance is designed to provide a minimum of 5 ft of unvegetated area on either side of the perimeter fence as required for airport security. Native plant species that will not attract hazard wildlife (see Table 5.1-12) will be planted adjacent to the channel. Monitoring and Performance Standards

The drainage channels will be monitored consistent with the monitoring approach, methods, schedules, and reporting outlined in Chapter 4. Hazard wildlife will be monitored consistent with the Port's WHMP (Port of Seattle 2000). Monitoring and performance standards for the replacement drainage channels will evaluate not only the functioning of the drainage channels (flow conveyance, stability of substrate, evidence of erosion) and the vegetated buffers, but the hydrology of down slope wetlands as well. Specific performance standards, types of parameters to evaluate, and contingency measures for the replacement drainage channels are provided in Table 5.2-12. Replacement drainage channels will be monitored following the schedule and methods provided in Table 5.2-13.

Hydrology

The replacement drainage channel design provides surface water to support the hydrology of down slope wetlands to ensure that existing wetland functions are maintained. The depth and duration of soil saturation will be monitored periodically during the 10-year monitoring period in wetlands between the embankment and Miller Creek (i.e., Wetlands 18 and 37). Groundwater monitoring will use standard groundwater monitoring wells installed in the wetlands between the embankment and Miller Creek. Groundwater levels will be monitored monthly for the first 5 years of the monitoring period, and then every other month for the remainder of the monitoring period. Specific performance standards and contingency measures for maintaining hydrology in down slope wetlands are included in Table 5.2-12.

Vegetation

Vegetation in the drainage channel buffers will be monitored to evaluate plant survival, native plant cover, invasive species cover, plant density, and overall health and vigor consistent with the approach outlined in Chapter 4.

5.2.3.9 Site Protection

The channels will be protected from adjacent airport development by fencing and signs that designate the area as permanently protected mitigation sites. The area will be covered by the restrictive covenants drafted to permanently protect the mitigation sites (Appendix G).

Table 5.2-12. Final performance standards, evaluation approach, and contingency measures for replacement drainage channels.

Design Criteria	Performance Standard	Evaluation Approach	Contingency Measures ¹
Construct the replacement channel to convey the 100-year, 24-hour design storm. Channel depths will be a minimum of 2 ft deep with side slopes of 3:1 or flatter; or if slopes are steeper, log and rock weirs will protect channel banks.	Replacement channels will meet or exceed design criteria for high flow. No evidence of channel erosion (bank cutting or scour) will be present.	Verify with record drawings. Monitor flows in channel.	Enlarge channel if conveyance is inadequate. Re-contour side slopes if greater than 3:1.
Construct channels down gradient and hydrologically connected to the drainage layer of the embankment.	Drainage channel is hydrologically connected to the drainage layer of the embankment.	Verify with record drawings	Modify channel to meet design standards.
Direct water in drainage channels to discharge points in or adjacent to riparian wetlands along Miller Creek (Wetlands A13, 18, 37a, 39, 44a, R9).	Flowing water will be present in the lower portions of the channels from December to June in years of normal rainfall. Water is directed to downslope wetlands and the hydrology of downslope wetlands will be maintained: <ul style="list-style-type: none"> Wetlands with predominantly organic soils (Portions of Wetland 18, 37a, R14a, A14b, and 44a) will have soils saturated in the upper part to mid-June in years of normal rainfall. Other wetlands with predominantly mineral soils will have soils saturated in the upper part to mid-April in years of normal rainfall. 	Measurements of channel baseflow by installing weirs that allow quantity of water flowing through channels to be determined. Monitor duration and depth to water table in wetlands to determine if wetland hydrology persists.	Modify discharge points from channel to wetlands to meet performance standards. Divert treated stormwater from up slope stormwater ponds to drainage channels. Improve drainage paths to convey water to wetlands. Remove obstructions and/or enlarge channels as needed. Reconfigure drainage channels to maintain flows (i.e., longer drainage channels to collect more water for distribution to wetlands). Divert treated stormwater from up slope stormwater ponds to drainage channels (the source of this stormwater could be from biofiltration swales, filter strips, etc. treating runoff from the perimeter road). Reconfigure discharge (i.e., location, size and number of discharges that distribute water to wetlands from drainage channels). Construct channel length according to design plans.
Construct new channels with a minimum length of 1,290 ft.	A total of 1,290 ft of new channel lengths will be constructed.	Record drawings.	

Table 5.2-12. Final performance standards, evaluation approach, and contingency measures for replacement drainage channels (continued).

Design Criteria	Performance Standard	Evaluation Approach	Contingency Measures ¹
Channel substrate will be stable.	Substrate materials will be a mix of sands and gravel. No evidence of erosion (sloughing banks) or scouring of substrate.	Visual observations following flood events and during monitoring visits to determine if scour is present.	Install additional bioengineering and bank stabilization. Install log weirs, check dams to prevent erosion in channels.
Plant native shrubs at greater than 2,100 individuals per acre and native trees greater than 280 trees per acre, along channel banks.	Channel depths will be a minimum of 2 ft deep with side slopes of 3:1 or flatter; or where slopes are steeper, log weirs will protect channel banks. Shrub density will be at least 2,100 individuals per acre. Tree density will be at least 280 stems per acre. Average tree and shrub survival will be at least 80% in the first 3 monitoring years. Average canopy cover of native species will be at least 80% by monitoring year 10. By the end of year 3, plant diversity in each stratum will not decrease by more than 10% from the number and type of plants installed at baseline. Canopy cover of non-native invasive species will be no more than 10% by monitoring year 10.	Record drawings. Vegetation sampling (plots, transects, or plotless techniques) to estimate cover, density, mortality, and invasive species.	Reconstruct to meet design criteria. If standards are not met: <ul style="list-style-type: none"> • Select species that are better adapted to existing hydrologic conditions. • Install additional plant material. • Install protective collars to reduce herbivore damage.

¹ For all performance standards, monitoring periods may be extended if performance standards are not met.

Table 5.2-13. Monitoring schedule for the replacement drainage channels.

Feature	Method	Frequency of Inspection	Data Collection Year (calculated as years following completion of mitigation)												
			0	1	2	3	4	5	6	7	8	9	10		
Substrate	Inspect for evidence of erosion or scouring	Annually (May) or after 2-year storm during the first 3 years	X	X	X	X	X	X	X	X	X	X	X	X	X
Hydrology	Inspect following flood events; measure base flow	Twice yearly (February/November)	X	X	X	X	X	X	X	X	X	X	X	X	X
Downslope Wetlands	Groundwater monitoring	Monthly	X	X	X	X	X	X	X	X	X	X	X	X	X
Buffer Vegetation	Vegetation sampling	Annually (late spring or early summer)	X	X	X	X	X	X	X	X	X	X	X	X	X

AR 048789

5.2.3.10 Maintenance and Contingency Plans

Routine maintenance and contingency measures will be implemented for the replacement drainage channels consistent with the overall approach outlined in Chapter 4.

Specific contingency measures for the drainage channels are provided in Table 5.2-12. If flow rates and hydrology are substantially different from the design flows used to develop this plan, the channels may not function as designed and the channel section can be modified by:

- Widening the base flow channel to reduce velocities and improve capacity
- Narrowing the base flow channel with logs or boulders to increase base flow depth and velocity
- Widening the flood flow portion of the channel (above 0.5 ft) to improve capacity and reduce velocity
- Adding log weir steps—to flatten stream slope, reducing velocity and increasing base flow depth
- Adjusting discharge points to Wetlands A13, 18, 37a, 39, 44a and R9 or other wetlands as necessary

5.2.4 Wetland Restoration Plan for Temporary Construction Impacts

Construction of the third runway embankment will result in some temporary wetland impacts (described in Section 5.2.4.2). Temporary impacts to wetlands are those that do not involve permanent filling or excavation, and include clearing of wetland vegetation; use of a wetland for temporary construction access roads, staging areas, or temporary stormwater management ponds; or minor disturbances associated with placement of barrier and sediment fencing. Temporary impacts will last 1 to 5 years. A maximum of 2.05 acres of wetlands (including 1.15 acres of forest, 0.46 acres of shrub, and 0.44 acres of emergent wetland) may be impacted temporarily by construction activities (Table 5.2-14). However, not all of these wetlands will necessarily be impacted by construction activities. During construction, all practicable means will be used to minimize and avoid temporary impacts, for example by reducing staging area or access road footprints, minimizing pond sizes, or re-routing access roads. Therefore, actual temporary construction impacts may be less than 2.05 acres. All wetlands temporarily impacted by construction activities will be restored and monitored to ensure performance standards are met (Table 5.2-15).

Following construction, wetlands temporarily impacted by clearing or filling will be restored by removing all temporary fill material, re-establishing pre-disturbance conditions, and planting with native forested and shrub vegetation. Wetlands with only minor disturbances that do not involve clearing of vegetation or filling (e.g., sediment fencing placed along the edge of a wetland) will be restored by removing sediment fencing, removing any other construction debris, and replacing any wetland vegetation disturbed by these activities.

Table 5.2-14. Summary of wetlands subject to temporary construction-related impacts.

Wetland	Classification ¹	Total Temporary Impact Area (acres)	Vegetation Type Impacted (acres)		
			Forest	Shrub	Emergent
Runway Safety Area Extension					
4	Forested ²	0.20	0.20	0.00	0.00
5	Forested/Shrub ²	0.20	0.10	0.10	0.00
9	Forested/Emergent	0.16	0.11	0.00	0.05
Third Runway					
18	Forested/Shrub/Emergent	0.22	0.04	0.07	0.11
37	Forested/Shrub/Emergent	0.71	0.50	0.10	0.11
44a	Forested/Shrub	0.28	0.18	0.10	0.00
A1	Forested/Shrub/Emergent ²	0.05	0.01	0.01	0.03
A12	Shrub	0.03	0.00	0.03	0.00
A13	Forested	0.01	0.01	0.00	0.00
R2	Emergent	0.02	0.00	0.00	0.02
South Aviation Support Area					
52	Forested/Shrub/Emergent ²	0.17	0.00	0.05	0.12
TOTAL		2.05	1.15	0.46	0.44

¹ All wetlands are palustrine, based on USFWS wetland classification system (Cowardin et al. 1979).

² Temporary impacts will be limited to installation of sediment fencing and other standard BMPs such as temporary seeding, straw mulch, interception swales, etc.

Table 5.2-15. Mitigation design objectives and criteria for restoration of temporary wetland impacts.

Goal and Design Objectives	Design Criteria
Restore wetlands to pre-construction conditions.	Grade areas to pre-construction elevations if pre-construction grades have been modified, amend soils with topsoil.
Provide wetland hydrology appropriate for each wetland vegetation cover type.	Grade to reestablish pre-construction hydrology. If removal of fill and/or grading does not re-establish wetland hydrology, water from the replacement drainage channels will supplement hydrology.
Re-vegetate impacted wetland areas.	Restore impacted areas with native forest vegetation. Emergent wetland communities will be replanted with forest vegetation to increase wetland functions and reduce potential use by waterfowl.
Stabilize soils in upland areas adjacent to restoration areas.	Disturbed ground within 50 ft of the wetlands will be hydroseeded or otherwise stabilized to prevent erosion impacts to the wetland.

5.2.4.1 Goal, Objectives, and Design Criteria

The primary goal of this plan is to ensure no net loss of wetland functions by restoring wetlands temporarily impacted by construction activities to their pre-construction size with an overall increase in function (e.g., replace non-native emergent vegetation with native forested vegetation).

Design objectives and design criteria were developed (see Table 5.2-15) to ensure that restoration goals have been met at the end of the 10-year monitoring program.

5.2.4.2 Wetlands Site Description

A total of 11 wetlands (see Table 5.2-14) may be temporarily disturbed by MPU project construction activities (see Figure 3.1-3; Appendix D, Sheets C2 and C3 through C7). These wetlands lie within three general project areas: the RSA and South 154th Street relocation, the third runway embankment and the SASA. Wetlands subject to temporary construction related impacts are listed in Table 5.2-14. A complete description of these wetlands is included in the *Wetland Delineation Report* (Parametrix 2000c).

Runway Safety Areas and South 154th Street Relocation

Wetlands 4 and 5 are located near the north end of the existing runways where required RSA extensions will be built. As part of the safety extensions, South 154th Street will be relocated several hundred feet to the north, adjacent to these wetlands. Temporary disturbance to small portions of Wetlands 4 and 5 (about 0.40 acre) could result from placement of silt fences and required temporary erosion and sediment control actions.

Third Runway Embankment

Eight wetlands occur near the edge of fill for the third runway embankment. Temporary disturbance will occur in portions of Wetlands A1 (0.05 acre), A12 (0.03 acre), A13 (0.01 acre), R2 (0.02), 18 (0.22 acre), and 44a (0.28 acre) outside the area of permanent fill. During the relocation of South 154th Street, portions (0.16 acre) of Wetland 9 will be temporarily disturbed by construction activity. Minor disturbance could occur in limited portions of these wetlands as a result of installing silt fences around the construction area.

In addition to the impacts described above, approximately 0.71 acre of Wetland 37a will be directly disturbed from the construction of temporary stormwater management facilities, including a detention pond. The pond will be used to temporarily store construction stormwater that is pumped to an upland sedimentation pond. These stormwater facilities will be removed and the wetland area restored after the completion of the third runway. Permanent stormwater facilities will be located outside of wetland areas.

South Aviation Support Area (SASA)

Wetland 52 (i.e., Tyee Pond) is adjacent to the SASA project. Temporary impacts (approximately 0.17 acre) may occur during construction of the taxiway connecting the SASA to the airfield. Impacts to the wetland could include minor sedimentation or soil disturbance resulting from construction.

Temporary Impacts Resulting from Mitigation Projects

Approximately 38.8 acres of wetland area (in both on- and off-site mitigation areas) will be subject to enhancement and restoration activities such as grading, weed control, and planting (see Table 3.1-4). In general, these activities occur to Category III or Category IV wetlands that are farmed or dominated by non-native vegetation. For example, approximately 3.74 acres of Wetland A1, a

Category II riparian wetland, would be temporarily disturbed by construction associated with the relocation of Miller Creek, floodplain grading, and planting. Two emergent Category III wetlands at or near the off-site mitigation area in Auburn, Washington (see Chapters 4 and 7) will be altered by the placement of temporary construction access roads. All of these wetlands will be enhanced or restored by the proposed mitigation actions, with an overall increase in wetland function resulting from the mitigation action. These actions are described in detail in the sections discussing the individual mitigation projects.

5.2.4.3 Rationale for Selection

Those wetlands temporarily impacted from construction activities will be restored on-site. Mitigation of temporary impacts provides the opportunity to enhance or restore functions in wetlands that are currently degraded. Following mitigation of temporary impacts, these wetlands will be vegetated with native forested and shrub wetland species, and wetlands will be protected by 50-ft-wide upland buffers where possible.

5.2.4.4 Constraints

No significant constraints have been identified that would preclude implementing restoration plans for temporarily impacted wetlands.

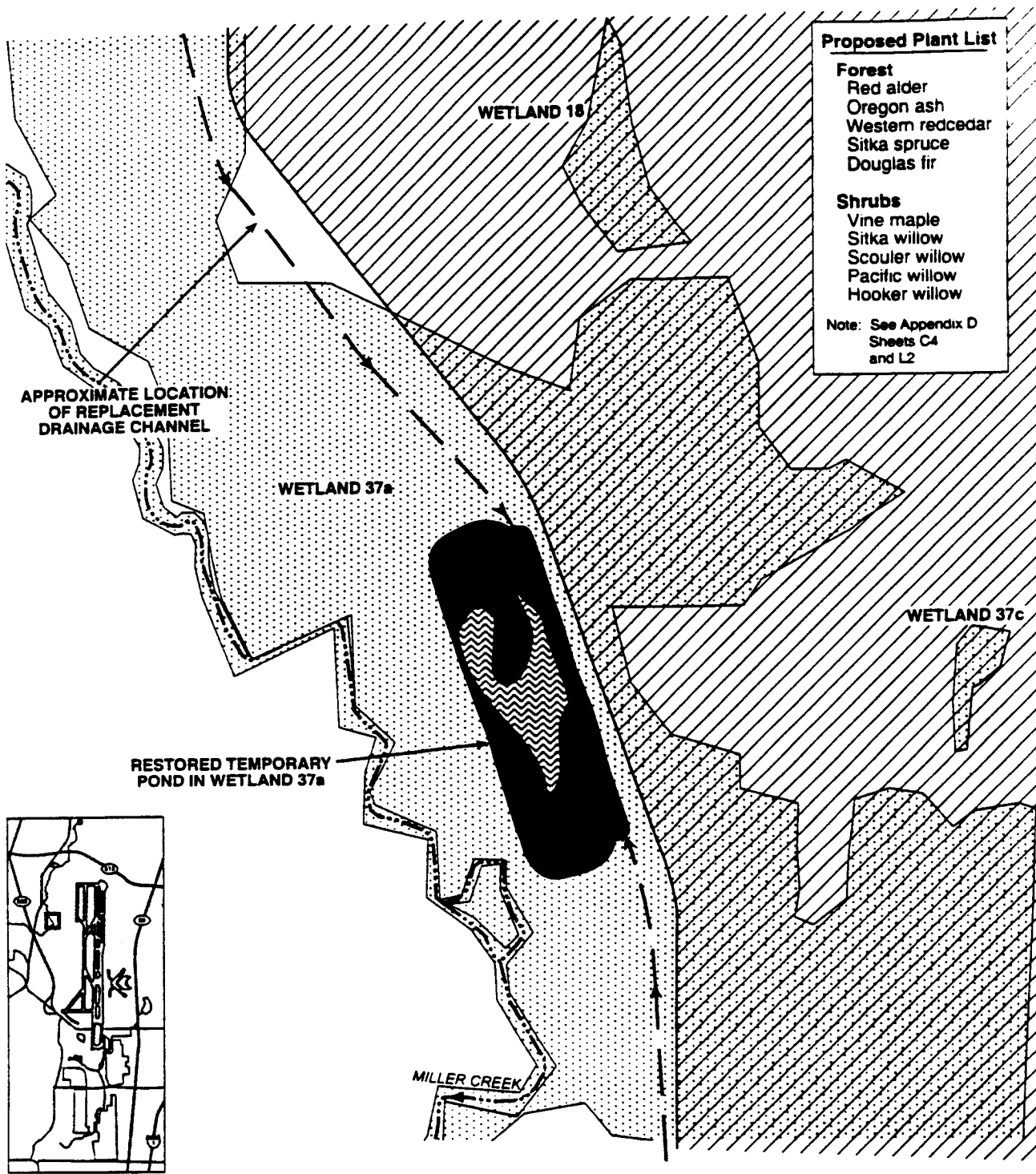
5.2.4.5 Ecological Assessment of the Mitigation Sites

Ecological conditions in the temporarily impacted wetlands are discussed in detail in the *Wetland Delineation Report: Seattle-Tacoma International Airport Master Plan Update Improvements* (Parametrix 2000c). A general description of existing conditions in these wetlands is included in Chapter 2 of this report.

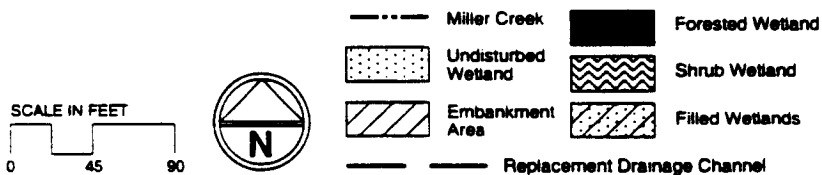
5.2.4.6 Temporary Impact Mitigation Design

Mitigation of temporary impacts varies on the nature of the impact, and specific mitigation plans are included in Appendix D. On completion of construction, all fill material and any construction material, equipment, or debris will be removed from the wetland. The area will be regraded if necessary to re-establish pre-disturbance topography. Hydrology will be re-established, if impacted, by directing seepage from the fill slopes to the wetlands via the replacement drainage channels. If necessary, tilling or discing of the soils to loosen compacted soils and addition of soil amendments will ensure a suitable planting medium. Native forested and shrub wetland vegetation will be restored by planting species such as Sitka spruce, black cottonwood, western redcedar, Pacific willow, Oregon ash, Pacific ninebark, and Sitka willow (Figures 5.2-17 and 5.2-18).

Wetlands with temporary impacts that do not include clearing of vegetation or temporary filling (i.e., installation of sediment or barrier fencing) will be restored by removing all construction materials or debris. Vegetation disturbed by construction activities in these areas will be replaced.



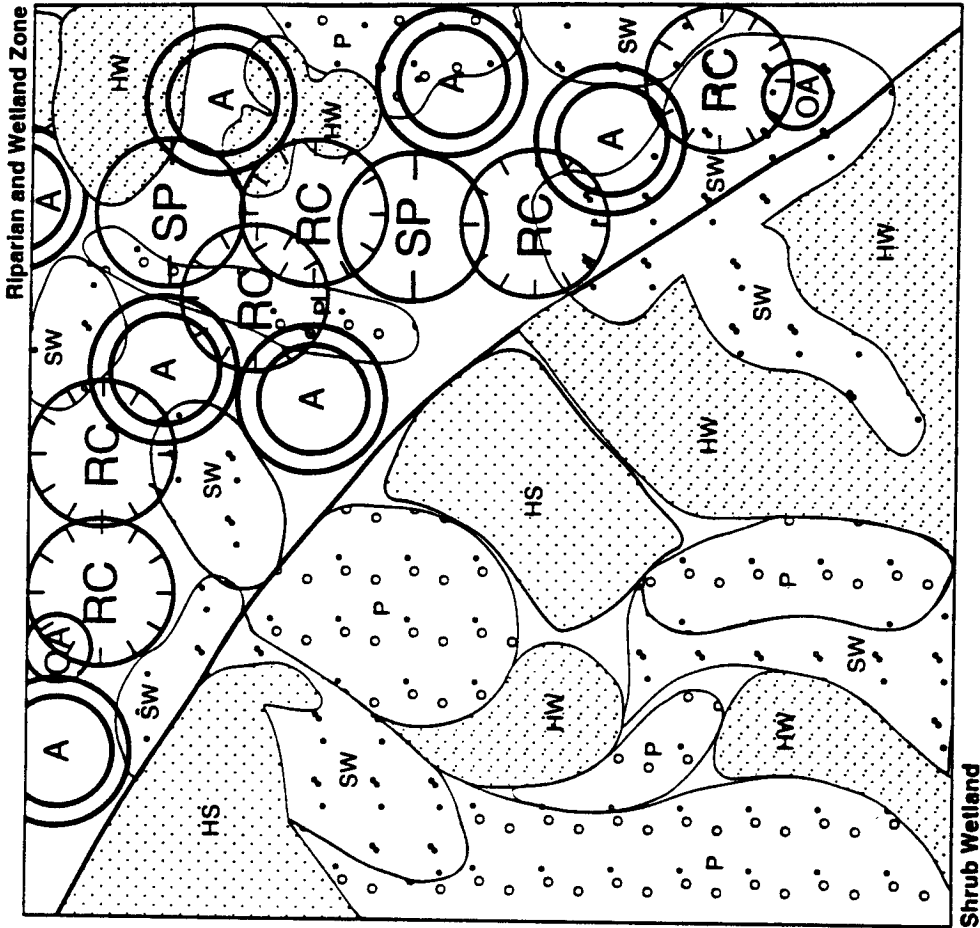
Port of Seattle/Natural Resource Mitigation Plan/556-2912-001/01(03) 12/00 (K)



**Figure 5.2-17
 Typical Planting Plan for
 Wetland 37 Restoration**

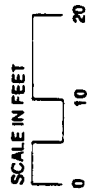
Riparian and Wetland Zone

- Western Redcedar
 - Red Alder
 - Oregon Ash
 - Scouter's Willow
 - Sitka Spruce
 - Hooker's Willow
 - Pacific Willow
- Shrub Wetland**
- Scouter's Willow
 - Hooker's Willow
 - Pacific Willow
 - Hardhack Spirea



Note: See Appendix D Sheet L2

Part of Seattle/Natural Resource Mitigation Plan 556-2912-00101(03) 1100 (K)



**Figure 5.2-18
Typical Planting Plan
for Restoration of Temporary
Wetland Impacts**

Finally, any areas outside of wetlands or wetland buffers that are disturbed by construction will be hydroseeded with a standard erosion control seed mix to stabilize the soils and prevent erosion. Hydroseeding will also provide ground cover and reduce the amount of habitat available for non-native weedy species that could affect the success of the wetland mitigation sites.

Mitigation plans for temporary wetland impacts will be coordinated as needed with the mitigation actions for the adjacent Miller Creek wetland and riparian buffer enhancement projects (Sections 5.2.1 and 5.2.2).

Wildlife Considerations

Planting plans developed for the temporary impact mitigation are similar to those developed for the Miller Creek wetland and riparian buffer enhancement projects. These plans are consistent with the Port's WHMP and include species that are not likely to attract hazard wildlife (see Table 5.1-12; Appendix D, Sheet L1).

Landscape Plan

Specific landscape plans for temporarily disturbed wetland areas are shown in Appendix D, Sheet L1. A typical planting plan (see Figure 5.2-18) shows how the wetland areas will be replanted after construction is completed.

Expected Hydrology

All temporarily impacted wetlands will be restored to pre-disturbance conditions (including topography) and therefore it is anticipated that hydrology in the restored wetlands will be similar to pre-construction conditions. The replacement drainage channel system is designed to ensure that hydrology in wetlands down slope of the embankment will be maintained. Performance standards and monitoring for wetlands down slope of the embankment are provided in Tables 5.2-11 and Table 5.2-12.

5.2.4.7 Performance Standard and Contingency

Performance standards, types of parameters measured, and contingency measures for temporary impact mitigation are listed in Table 5.2-16. The monitoring schedule for temporarily impacted mitigation sites is provided in Section 5.2.4.9.

5.2.4.8 Implementation

Temporary impact mitigation projects will be coordinated with third runway construction activities, as well as with Miller Creek riparian wetland and buffer enhancement projects. Implementation of the replacement drainage channels and the temporary impacts mitigation is described in Section 5.2.4.12.

Table 5.2-16. Final performance standards, evaluation measures, and contingency measures for restoration of temporary wetland impacts.

Design Criteria	Performance Standard	Evaluation Methods	Contingency Measures ¹
Grade areas to pre-construction elevations if pre-construction grades have been modified, amend soils with topsoil.	Pre-disturbance wetland topography is restored, as determined by comparing to pre-construction contour maps.	Comparison of pre- and post-construction topography.	Minor regrading if necessary.
Grade to reestablish pre-construction hydrology. If removal of fill and/or grading does not re-establish wetland hydrology, water from the replacement drainage channels will supplement hydrology.	Wetland areas will meet wetland criteria (hydrophytic vegetation, hydric soils, hydrology) following restoration. Soils in wetlands will be saturated in the upper 10 inches for a minimum of 2 weeks during the growing season, in years of normal rainfall.	Monitor the depth to and the duration of soil saturation.	Install additional plant material. Install protective collars. Control/reduce non-native invasive species.
Restore impacted areas with native forest vegetation. Emergent wetland communities will be replanted with forest vegetation to increase wetland functions and reduce potential use by waterfowl.	Average survival of planted stock will be at least 80% in the first 3 monitoring years. Canopy cover of native species will be at least 80% by the end of the 10-year monitoring period. In re-vegetated wetlands, canopy cover of non-native invasive species will be no more than 10% at the end of the 10-year monitoring period. Re-vegetated wetlands will be a tree density of at least 280 stems per acre and a shrub density of at least 2,100 individuals per acre.	Vegetation sampling (plots, transects, or plotless techniques) to estimate mortality, cover, density, and presence of invasive species.	If standards are not met: Select species that are better adapted to existing hydrologic conditions. Install additional plant material. Install protective collars to reduce herbivore damage.
Disturbed ground within 50 ft of the wetlands will be hydroseeded or otherwise stabilized to prevent erosion impacts to the wetland.	By the end of year 3, plant diversity in each stratum will not decrease by more than 10% from the number and type of plants installed at baseline. No evidence of soil erosion (rilling, scour) or sediment transport (deposition) in the wetland is visible.	Verify with record drawings; monitor wetlands for evidence of erosion or sediment deposition	Install erosion control fabric. Install additional hydroseed or plants in uplands areas.

¹ For all performance standards, monitoring periods may be extended if performance standards are not met.

5.2.4.9 Monitoring and Performance Standards

The overall monitoring approach for the temporary impact mitigation will be consistent with the monitoring approach outlined for all MPU mitigation projects in Chapter 4 of this report. Monitoring tasks specific to the temporary impact mitigation projects are described in this section. Performance standards, methods and parameters, and contingency measures for the temporary impact mitigation are listed in Table 5.2-16. The monitoring schedule for temporarily impacted mitigation sites is provided in Table 5.2-17.

Table 5.2-17. Monitoring schedule for restoration of temporary wetland impacts.

Feature	Activity	Frequency	Data Collection Year											
			0	1	2	3	4	5	6	7	8	9	10	
Wetland hydrology	Groundwater monitoring	Monthly	X	X	X									
		Once winter, late spring/ early summer, and fall				X	X	X	X	X	X	X	X	X
Vegetation communities	Vegetation sampling	Once late spring or early summer	X	X	X	X		X		X				X

Hydrology

Monitoring of temporarily impacted wetlands, as well as wetlands between the embankment and Miller Creek will focus particularly on evaluating wetland hydrology. To ensure that performance standards are met, and to aid in determining appropriate contingency measures, monitoring will include a pre-construction topographic survey and groundwater monitoring. A topographic survey of all wetlands within the temporarily impacted area will be conducted before grading for the runway embankment. This survey will be used as a baseline to re-establish pre-construction contours. Shallow groundwater monitoring wells will be installed within restored wetlands following mitigation regrading and planting. Groundwater levels will be monitored monthly to determine presence of wetland hydrology sufficient to maintain existing or planted vegetation.

Vegetation

Temporarily impacted wetlands that are replanted will be restored as palustrine forested wetlands and therefore will be monitored for at least 10 years. Vegetation will be monitored using the approach outlined in Table 5.2-16.

5.2.4.10 Site Protection

Areas subjected to temporary impacts will be protected as established in the restrictive covenants (Appendix G) and other federal, state, and local regulations that protect wetlands.

5.2.4.11 Maintenance and Contingency Plans

Routine maintenance and contingency measures will be implemented for the temporarily impacted mitigation sites consistent with the overall approach outlined in Chapter 4.

Contingency measures for each performance standard for the temporary impact mitigation projects are listed in Table 5.2-16. Contingency measures will be consistent with the adaptive management approach outlined in Chapter 4.

5.2.4.12 Implementation of Replacement Drainage Channel and Temporarily Impacted Mitigation Projects

The locations of the wetlands subject to temporary impacts and drainage channel mitigation sites are shown in Appendix D. Implementation of mitigation activities for temporarily impacted wetlands is dependent on phasing for the construction of the third runway embankment and decommissioning of temporary stormwater detention ponds for the runway embankment construction. Drainage channel construction will occur before and during construction of the embankment (approximately 2000 to 2005). Temporary wetland impact restoration will occur immediately after completion of individual projects impacting wetlands (i.e., South 154th Street relocation embankment).

Prior to the start of construction, a pre-construction meeting between the contractor, engineer, and wetland scientist will determine the exact areas needed for construction activities. These temporary construction impact areas will be located to avoid and minimize impacts to wetlands. Construction limits will be clearly marked in the field to avoid impacts to wetlands outside the temporarily impacted areas.

On completion of construction, all construction debris and equipment will be removed from temporarily impacted areas. Any temporary access roads will be removed. Any fill material will be removed. Temporarily impacted areas will be returned to pre-disturbance conditions and drainage channels will be graded per specifications (Appendix D, Sheets L1 and C9). Soils that have been compacted by construction activities will be deep ripped if necessary, and will be tilled to a depth of 10 to 14 inches to provide suitable conditions for planting. Disturbed areas will be hydroseeded to stabilize the soil and native plant species installed to establish forested wetland vegetation (Appendix D, Sheets L1 and C9). Planting will occur during the early fall following temporary mitigation or drainage channel construction. Sediment and erosion control measures may be removed 1 full year after planting if these sites are stable. Replacement drainage channel buffers will also be planted with native trees and shrubs. Temporarily impacted and drainage channel mitigation sites will be monitored annually for a period of 10 years to ensure they are meeting performance standards.

5.2.5 Miller Creek Basin Trust Fund for Watershed Rehabilitation

To provide opportunities for additional restoration projects in the Miller Creek basin, the Port will establish a trust fund to support watershed rehabilitation projects. The trust fund will focus on portions of Miller Creek not owned by the Port, and where the Port is unable to independently implement stream enhancement projects. The Port will make these trust funds available and defer

to other governmental agencies or interested groups in the selection of appropriate projects. Restoration or enhancement projects supported by the trust fund are independent of the environmental review and permit process for MPU projects (e.g., CWA 404/401, HPA), and would not be covered by any permit conditions on Port MPU construction or mitigation projects.

5.2.5.1 Goal

The goal of this mitigation action is to provide a funding source to local agencies and groups to enhance instream or riparian habitat for salmonids and other aquatic organisms in the Miller Creek basin. The trust fund provides an opportunity to involve the local community and community groups (i.e., Trout Unlimited) in planning meaningful restoration for Miller Creek.

5.2.5.2 Description

The trust fund for watershed restoration will provide \$150,000 for restoration projects in the Miller Creek basin. Potential projects eligible for funding by the trust fund are based on information provided in the Stream Survey Report for Miller Creek (Appendix F of the Final EIS for the Master Plan Update Projects [Port of Seattle 1997]). The projects identified below are a preliminary list and are proposed to address habitat problems in Miller Creek identified in the stream survey. Examples of projects eligible for full or partial funding could include instream fisheries habitat improvements similar to those proposed for Miller Creek in this plan (see Figures 5.2-8 through 5.2-11), riparian buffer enhancement, removal of fish passage barriers, and removal of failed septic systems.

While specific projects are not selected, a suite of potential projects is identified with their respective goals, general performance standards, and general monitoring requirements. Additional planning and engineering of selected projects will result in specific project designs, performance standards, monitoring requirements, and contingency measures.

The trust fund will have a sunset period of 2 years, with the 2-year period beginning once permits are issued for the MPU projects. If after a 2-year period trust fund projects are not designed and environmental permits sought,⁹ the Port will use the money to implement projects in the Miller Creek basin that would provide water quality or aquatic habitat benefits. The projects to be implemented will be at the discretion of the Port, but with approval from Ecology and ACOE.

5.2.5.3 Eligibility

The Port, or the designated administrator of the trust fund, will consider requests for monies from the watershed trust fund to implement stream habitat enhancement projects. Requests must be made by King County, City of SeaTac, City of Des Moines, City of Burien, City of Normandy Park, special districts, tribal governments, non-profit organizations, or combinations of such governments through inter-local agreements. Organizations requesting funding must comply with general liability insurance requirements established by the Port.

⁹ Project proponents will be responsible for obtaining all federal, state, and local permits required to implement habitat enhancement projects.

Key criteria to be used to evaluate proposals to implement projects in Table 5.2-18, as well as other projects within the watershed, are:

- A demonstrated benefit to salmon or aquatic habitat without creating significant avian wildlife habitat within 10,000 ft of runways at STIA.
- Consistency with watershed management plans, or with prescriptions/recommendations identified using watershed analysis or stream assessment procedures.
- Clearly defined project goals, implementation plans, performance standards, and post-project monitoring.
- Preference for resolving underlying causes of problems rather than treating symptoms.
- Cost-effectiveness.

5.2.5.4 Implementation

The Miller Creek Basin Committee, the King County Watershed Coordinator, or other responsible entity will administer the fund. The administrator will establish eligible project criteria, create application forms, set project cost limits, and set implementation and monitoring requirements. The Port will review and approve all project goals, plans, performance standards, and monitoring requirements to enhance ultimate success of the projects.

5.2.5.5 Site Protection

Site protection measures for enhancement projects will be coordinated with property owners and the fund administrator.

5.2.5.6 Monitoring and Contingency Plans

The fund administrator will review project design, implementation, and the as-built plans to verify that intended benefits have been built. Contingency actions associated with establishment or operation of the fund will be reviewed with the Port, ACOE, Ecology, and the fund administrator.

Table 5.2-18. Potential trust fund projects in the Miller Creek watershed.

Project	Goals	Description	Performance Standards	Monitoring
Pool Habitat Improvements (RM 2.0 to 3.3)	Increase high-flow refugia and over-wintering habitat for resident and anadromous fish species.	Modify stream channel to increase size, depth, and cover of existing pools. Create additional pools through placement of LWD complexes (4 to 6 logs each) instream channel.	Established pools and riffles will remain stable, or pool/riffle ratio shall remain within 10% of established value over 10 years.	Assess functions of pool/riffle complex annually at the end of the wet season to determine habitat quality of existing and created pools.
Streambank Stabilization (RM 2.0 to 3.3)	Increase quality spawning gravels and escape cover for juvenile salmonids and habitat for aquatic invertebrates by increasing stability of streambanks prone to slump and landslide activity.	Apply prescriptive stabilization designs to eroding banks, landslide areas, slumps, and debris jams that are major contributors to sediment loading.	Streambank stabilization projects shall remain intact for the 10-year monitoring period.	Assess stabilized streambanks annually at the end of the wet season, noting soil stability, evidence of sediment loading in the stream channel, and potential for sediment loading.
Streambank Re-vegetation (RM 2.0 to 3.3)	Decrease seasonal water temperature fluctuation through shading stream channel with native vegetation.	Install native riparian vegetation to provide overhead cover and shading of stream channel.	Installed plant materials shall have minimum 80% survival after 3 years, and shall provide a minimum of 80% cover of native species by year 10.	Assess installed plant materials and percent cover of non-native invasive vegetation species annually at the end of the growing season.

**Des Moines Creek
Restoration Project**

AR 048803

5.3 DES MOINES CREEK BASIN RESTORATION PROJECTS

MPU improvement projects will result in approximately 3.88 acres of permanent wetland impacts in the Des Moines Creek basin (Borrow Area 1, Haul Road, and SASA; see Table 3.1-2). These unavoidable impacts will result from the development of the SASA and excavation activities in the borrow areas. Therefore, to mitigate for these impacts in the Des Moines Creek basin, the Port proposes restoration and enhancement projects designed to increase wetland function, enhance aquatic habitat, and improve stream conditions within Des Moines Creek. These mitigation projects are designed to ensure that new wildlife hazards are not created near the airport. This integrated set of projects is designed to meet the following overall objectives:

- Restore wetland functions to a portion of the Tye Valley Golf Course by restoring a native wetland shrub community.
- Enhance aquatic habitat and improve stream functions by restoring a forested riparian buffer along a 870-ft of the west branch Des Moines Creek, also located on the Tye Valley Golf Course.
- Establish a \$150,000 trust fund for restoration projects located in the Des Moines Creek basin.
- Provide for additional stream enhancement projects and local restoration efforts.

To provide additional protection to Des Moines Creek, the Port will plant a 100-ft buffer along Des Moines Creek from the edge of the wetland mitigation site at the Tye Valley Golf Course south to the proposed South Access Freeway ROW. This buffer is not included as mitigation credit for project impacts, but is an action the Port will take to provide additional protection to the aquatic habitat in Des Moines Creek.

5.3.1 Mitigation Plans

Projects in the Des Moines Creek basin are designed to mitigate for unavoidable project impacts to wetlands and aquatic resources by restoring wetland and stream functions. To mitigate for wetland impacts and improve aquatic habitat in the Des Moines Creek watershed existing emergent wetland at the Tye Valley Golf Course will be enhanced by establishing a native shrub wetland community (Figure 5.3-1). Approximately 4.5 acres of wetland enhancement will occur in the Tye Valley Mitigation area and approximately 1.0 acre will occur in the west branch Des Moines Creek buffer. This mitigation will increase infiltration, reduce pollutant runoff, increase sediment retention, improve nutrient cycling functions in the wetland, and improve water quality and habitat in adjacent Des Moines Creek. Replacing the existing golf course turf grass by planting a native shrub community will also decrease hazard wildlife attractants within 10,000 ft of the airfield (as required by the FAA), by reducing use of the golf course by waterfowl.

To enhance water quality and aquatic habitat in Des Moines Creek, approximately 5 acres of buffers will be established along Des Moines Creek at the Tye Valley Golf Course. A 100-ft buffer (approximately 3.4 acres) will be enhanced on both sides of the west branch of Des Moines Creek (see Figure 5.3-1) and approximately 1.7 acres within the Tye Valley Golf Course Mitigation Area. These buffers will be planted with native forested and shrub riparian vegetation. Species planted in the buffer will be selected to avoid attractants to hazard wildlife, consistent with the Port's WHMP.

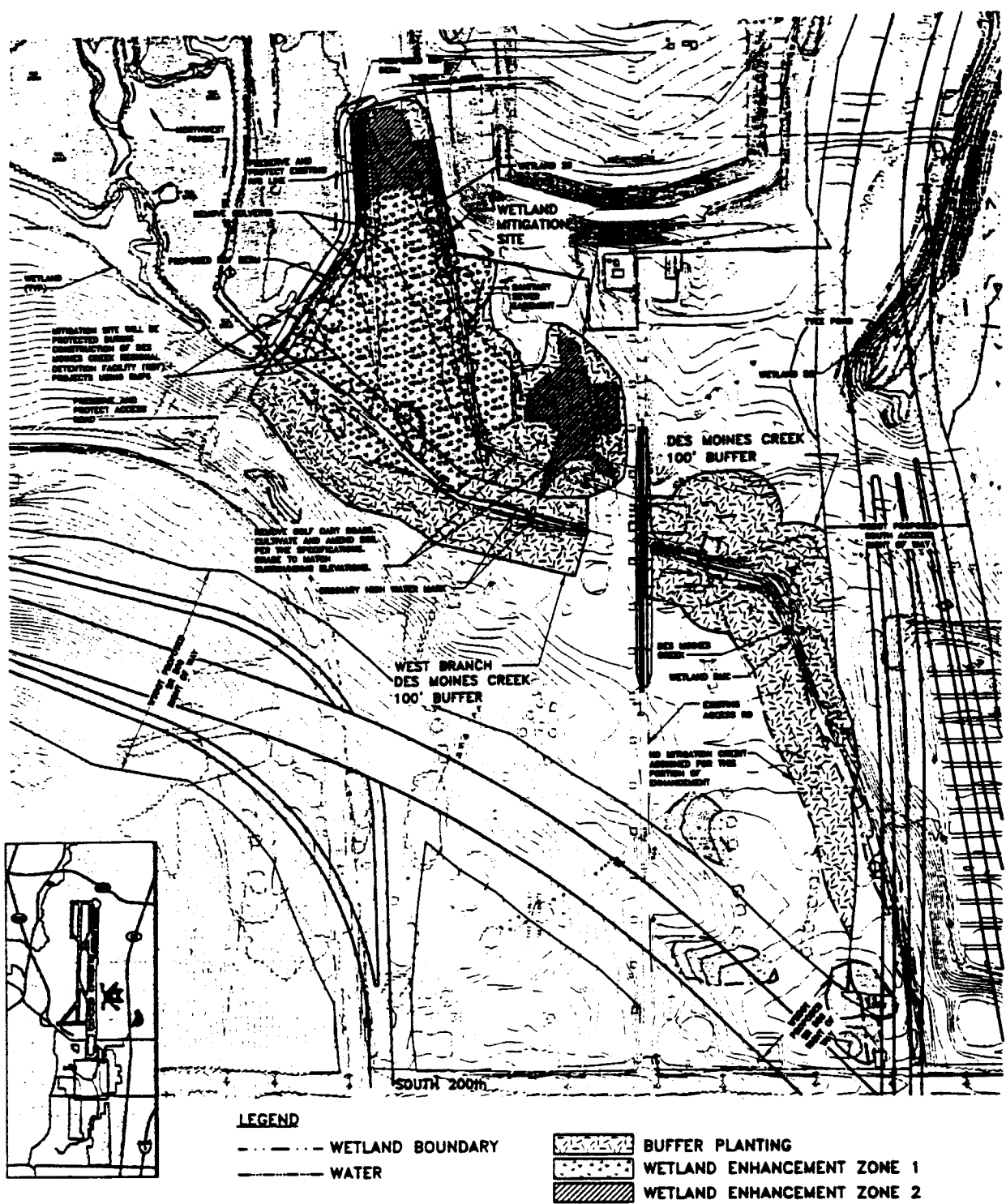


Figure 5.3-1
Location of Wetland Enhancement
On the Tye Valley Golf Course,
Des Moines Creek Basin

Enhancement of this buffer will increase infiltration in the buffer area; reduce sediment, nutrient, and pollutant inputs to the stream; and provide shade, large woody debris, and organic matter inputs to Des Moines Creek.

5.3.1.1 Goals, Objectives, and Design Criteria

The following section describes the goals, objectives, and design criteria identified for the Des Moines Creek projects. Goals identified for this plan include:

- Establish a total of 5.5 acres of native shrub wetland in a currently degraded emergent wetland (i.e., golf course turf) to improve water quality, fish habitat, and stream conditions in Des Moines Creek (4.5 acres in Tyee Valley Golf Course Mitigation Area and 1.0 acre in west branch Des Moines Creek buffer; see Table 4.1-3).
- Reduce hazard wildlife (e.g., Canada goose and other waterfowl species) use of the golf course area by replacing turf grass wetland with shrub wetland.
- Improve water quality and aquatic habitat in Des Moines Creek by planting a 100-ft forested buffer along both banks of an 870-ft section of Des Moines Creek.

Specific design objectives and criteria developed to ensure that the Des Moines Creek projects meet mitigation goals are listed in Table 5.3-1.

Table 5.3-1. Mitigation goals, design objectives, and design criteria for wetland and buffer enhancement on the Tyee Valley Golf Course.

Goals and Design Objectives	Design Criteria
Goal 1: Enhance degraded wetlands to provide improved water quality and aquatic habitat functions to Des Moines Creek	
Enhance existing turf-dominated wetland at the Tyee Valley Golf Course.	Plant 5.5 acres of the golf course wetland with native wetland shrub species (include wetland area on left and right bank west branch Des Moines Creek). Shrub and small trees planted density will be 3,375 individuals per acre
Goal 2: Reduce waterfowl use of the golf course area	
Reduce habitat value of the mitigation area for water fowl.	Plant area with shrub vegetation to discourage use of wetland by waterfowl.
Goal 3: Improve water quality and aquatic habitat in Des Moines Creek by restoring riparian buffers.	
Establish protected buffers 100 ft wide riparian buffers.	Plant 100-ft-wide riparian buffers on each side of Des Moines Creek (approximately 3.38 acres of buffer area). Plant native riparian forested and shrub plant species within the 100-ft buffer along Des Moines Creek.

5.3.1.2 Mitigation Site Descriptions

Tyee Valley Golf Course

The Tyee Valley Golf Course is an active golf course located at the southern end of the STIA runways (see Figure 2.1-1). The golf course occurs in the eastern portion of Wetland 28, an approximately 35-acre wetland complex associated with the Northwest Ponds and Des Moines Creek. The portion of the wetland associated with the Northwest Ponds (west of the golf course) contains forest, shrub, emergent, and open-water wetland habitat. The golf course portion of Wetland 28 contains an approximately 9.75-acre emergent turf-grass wetland. Wetland enhancement will occur in emergent turf-grass wetland (see Figure 5.3-1). A detailed description of Wetland 28 is provided in the *Wetland Delineation Report* (Parametrix 2000c).

Des Moines Creek

The west branch of Des Moines Creek originates at the Northwest Ponds or Wetland 28 (see Figure 2.1-3). The Northwest Ponds, located southwest of the existing runways between South 192nd Street and South 196th Street, were excavated as a source of peat by the previous property owners, and subsequently incorporated into the airport's stormwater management system. The east fork of Des Moines Creek originates in Bow Lake, east of the airport, and flows south, mostly via closed pipes, to the Tyee Valley Golf Course detention pond (Tyee Pond; Wetland 52). From Tyee Pond, the east branch flows through a culvert to join the west branch southeast of the proposed wetland mitigation site (see Figure 5.3-1). South of the confluence, Des Moines Creek flows through the Tyee Valley Golf Course to South 200th Street and then generally south to Puget Sound.

5.3.1.3 Ownership

The Port owns the property in the Des Moines Creek mitigation areas (i.e., golf course, buffer zone of Des Moines Creek). The golf course is currently leased to a golf course operation, which will cease before implementation.

5.3.1.4 Rationale for Selection

The Des Moines Creek mitigation projects provide an opportunity to mitigate for wetland impacts on-site in the Des Moines Creek basin. Mitigation will occur through restoring portions of a historic peat wetland adjacent to the upper reaches of Des Moines Creek, enhancing riparian buffers along Des Moines Creek, and mitigating for potential indirect impacts to wetlands down slope of the project area.

Historic land uses resulted in converting a native peat wetland to a golf course, as well as replacing forested wetlands and riparian areas along Des Moines Creek with open turf grass areas or areas of non-native invasive species. These alterations have degraded aquatic habitat in Des Moines Creek, increased sediment and nutrient inputs to the stream, and removed the buffering influence of riparian vegetation. Using the Tyee Valley Golf Course as a mitigation site provides a unique opportunity to enhance an existing wetland and restore a native wetland shrub habitat adjacent to a salmon-bearing stream. This mitigation site also provides the opportunity to improve the aquatic habitat of Des Moines Creek by reducing pollutant runoff, increasing sediment retention, and increasing nutrient cycling by restoring both wetlands and riparian buffers along the stream.

Finally, the turf grass and seasonal flooding that occur on the Tyee Valley Golf Course attract a large number of waterfowl (e.g., Canada geese and widgeon) that forage on the mown lawn of the golf course. These waterfowl pose a threat to aircraft operation and safety, and establishing shrub vegetation will eliminate waterfowl from portions of the golf course and reduce aviation hazards.

5.3.1.5 Constraints

Mitigation design for these projects is constrained by the proximity of the mitigation sites to the airfield and runways. Proximity to the airfield affects the choice of plant species used in the design to ensure that wildlife hazards are not created. The size of buffer areas is constrained by nearby RSAs and embankments. Two separate and unrelated construction projects are also potential constraints that have affected the design and implementation of the Des Moines Creek projects. These projects are the King County Regional Detention Facility (RDF) proposed at the Northwest Ponds and the Washington State Department of Transportation (WSDOT) SR 509 extension and South Access Freeway.

These constraints will not prevent the plan from being implemented, but they could affect implementation steps (e.g., construction sequencing) or design (e.g., protective barriers around mitigation plantings). In addition, concerns have been raised by ACOE and Ecology regarding the hydrology of the wetland mitigation area. Although this is not a constraint on the mitigation, these concerns are addressed in this section. Finally, there are no constraints on mitigation for indirect hydrology impacts at the borrow areas.

Buffer Size

Site constraints preclude the installation of extensive forested buffers around the wetland mitigation site. Within the wetland mitigation site itself, there are shrub buffers on the north side of the enhanced wetland edge and the surrounding golf course (Appendix C, Sheet C2). On the south side, 100-ft buffers along Des Moines Creek will protect the wetland mitigation site and the stream. Wetland buffers cannot be enhanced east of the wetland mitigation site because these areas are within designated RSAs and runway embankment. In this area, emergency and non-emergency access, flexibility to maintain or modify vegetation, vegetation height limits, and the flexibility to maintain or supplement navigation equipment or other airfield facilities must be retained for the safe operation of the airport. However, these restrictions will preclude high-impact uses near the wetland mitigation site, thereby providing an effective land use barrier.

Wildlife Hazards

The FAA and USDA-WSD staff have evaluated the mitigation proposed for the Des Moines Creek basin for potential wildlife hazards to aviation. These agencies have determined that the mitigation results in a decrease in wildlife hazards near the airfield. New road construction (i.e., SR 509 extension and South Access Freeway) near the airport is not expected to increase wildlife hazards. Overall, modification of waterfowl habitat through the Port's mitigation (planting of existing emergent wetlands and buffers with shrub and forested vegetation) will reduce wildlife hazards.

Site Hydrology and Relationship to the King County/Des Moines Creek Regional Detention Facility

Hydrology

The Tyee Valley Golf Course wetland mitigation will occur on an existing peat wetland that historically supported forested and shrub vegetation. Existing soils and hydrology on the site would support forested or shrub wetland under existing conditions, in the absence of active measures to maintain the emergent turf grass vegetation of the golf course. Existing wetland conditions at the mitigation site are maintained by high groundwater and by precipitation during the winter months. Grading will not be necessary to create the hydrologic conditions necessary to restore shrub wetlands at the Tyee Valley Golf Course site because the site already has wetland hydrology sufficient to support native shrub wetlands.

Regional Detention Facility

The Des Moines Basin Planning Committee identified a preferred alternative for the RDF in November 1999. The objective of the RDF is to control erosive flows reaching Des Moines Creek and thereby restore salmon habitat (King County Capitol Improvement Project Design Team 1999). The proposal includes increasing storage capacity in the Northwest Ponds and some channel reconstruction in Des Moines Creek to deepen the channel south of the wetland mitigation site.

Wetland hydrology of the mitigation site will not be affected by the operation of the RDF because hydroperiods within the mitigation site will not be significantly affected by the RDF. The Tyee Valley Golf Course currently is inundated by overbank flow from Des Moines Creek to some extent during flood events. The 100-year floodplain of Des Moines Creek (under existing conditions) is entirely within the mitigation site, and within the boundaries of Wetland 28 (Appendix C, Sheet C3). Construction of the RDF will result in a slight decrease in flooding on the mitigation site because of proposed reconstruction of the stream channel adjacent to the mitigation and increased water storage in Wetland 28.

Using data from the King County RDF plan (King County Capital Improvement Design Team 1999), King County compared current water levels on the mitigation site as a result of the 10-year, 25-year, and 100-year floods, with water levels predicted to occur during these flood events after construction of the RDF. In all cases, water levels and the extent of inundation on the site are somewhat lower with the proposed RDF than under current conditions (Appendix C, Sheets C3 and C4). For example, under existing conditions without the RDF, 100-year flood elevations are approximately at the 250.5-ft contour, while with the RDF, the 100-year flood elevations are a foot lower, at the 249.5-ft contour. Under existing conditions, inundation by the 100-year flood at the mitigation site is approximately 3.1 acres, while with the RDF in operation, the 100-year flood would inundate approximately 2.1 acres. Therefore, construction of the RDF will slightly decrease inundation of the site during flood events. However, because wetland hydrology on the site is not driven by flood events, this decrease will not affect implementation of the mitigation plan. Even with the slightly lower levels of inundation during flood events predicted after construction of the RDF, the Tyee site will support the planned wetland shrub vegetation. The site will continue to support wetland vegetation and hydrology because the current wetland is maintained by a high groundwater table that results in saturated soil conditions, and not by overbank flooding.

The preferred alternative for the RDF includes a berm adjacent to the west side of the Tyee Valley Golf Course mitigation site and enhancement of a portion of Des Moines Creek south of the wetland mitigation site (Appendix C, Sheet C2). The Port will protect the wetland mitigation site from RDF construction by placing sediment fencing or other TESC measures, and orange barrier fencing at the edge of the mitigation site to ensure that any potential impacts from construction are avoided. Protection will include ecology blocks or rock gabions to protect the wetland mitigation site during RDF construction activities to ensure that construction equipment does not enter the wetland mitigation site or riparian buffer.

Riparian buffer enhancement (the area extending out a horizontal distance of 100 ft from the OHWM of the stream or from the edge of riparian wetlands, whichever is greater), along Des Moines Creek will be coordinated with construction of the RDF and will be planted by the end of 2004.

SR 509 Extension/South Access Freeway

The WSDOT SR 509 extension and South Access Freeway project will not constrain implementation of the Port's mitigation plan in the Des Moines Creek basin. These two projects involve extending SR 509 south of the proposed RDF and construction of an access road between SR 509 and the airport terminal ramps. All wetland mitigation has been designed to avoid conflicts with the preferred alternative for these projects.

The Port's proposed mitigation at the Tyee Valley Golf Course and along Des Moines Creek avoids the preferred alternative for SR 509 and the South Access Freeway (Appendix G). Surface water runoff from these roadways can be collected, treated, and diverted to prevent runoff impacts to the mitigation sites. Therefore, these projects would not affect the hydrologic or riparian functions desired for the mitigation site.

5.3.1.6 Ecological Assessment of the Mitigation Area

Detailed additional descriptions of wetlands, Borrow Areas, and Des Moines Creek in the mitigation projects area are provided in the *Wetland Delineation Report* (Parametrix 2000c).

Des Moines Creek

The west branch of Des Moines Creek originates at the Northwest Ponds, flows through the golf course to the confluence with the east branch, and the mainstem then flows south to Puget Sound. The channel and riparian zone of Des Moines Creek upstream of South 200th Street have been significantly altered as a result of golf course development. Des Moines Creek is on the 303(d) list for fecal coliform of unknown origin. The channel substrate in the reach of Des Moines Creek through the golf course is predominantly composed of sands and silts, with some scattered areas of gravels and cobble, and some areas of heavy accumulation of fine sediments. Riparian vegetation along Des Moines Creek in the golf course area is primarily turfgrass. Between the confluence and South 200th Street, there is a riparian zone approximately 25 ft wide vegetated with trees and shrubs. Existing riparian vegetation provides very little shade or organic matter inputs to Des Moines Creek.

Reduced use of the site by geese following conversion of the golf course to shrub wetland will reduce inputs of fecal coliform and nutrients to the stream. In addition, planting the golf course with native shrubs, as well as establishing a forested/shrub buffer along Des Moines Creek, will increase

nutrient cycling and retention in the buffer and is likely to further reduce nutrient inputs to the stream.

Tyee Valley Golf Course Wetland (Wetland 28)

Historically, the Tyee Valley Golf Course was a peat wetland that was farmed until about 1970. At this time, portions of the original wetland were converted to a golf course and stormwater management ponds.

Vegetation

The proposed wetland mitigation site is located on an active golf course consisting primarily of fairways, greens, and roughs. Several roadways used for emergency access or golf cart roads are constructed on fill and cross the mitigation site. Vegetation on the Tyee Valley Golf Course is predominantly non-native turf grasses (e.g., *Poa* sp., *Agrostis* sp.), with scattered patches of coniferous and deciduous trees. No native wetland plant communities currently exist on the golf course. Portions of Wetland 28 to the west of the proposed mitigation site are dominated by native shrubs such as Pacific and Sitka willows and red elderberry (*Sambucus racemosa*), with some scattered trees such as black cottonwood and red alder.

Soils

In the golf course area of Wetland 28, the wetland soil is primarily a black or dark brown histic peat to a depth of greater than 18 inches. Small areas of the site consist of very dark gray silty loam mineral soils, or very dark mucks and loams (Parametrix 2000c). Upland soils are very dark grayish brown silty loams.

Hydrology

Hydrology within the wetland is maintained by a high groundwater table, occasional flooding from Des Moines Creek, and precipitation. Wetland hydrology in the western portion of the golf course is supported by groundwater and some overbank flow from Des Moines Creek. Wetland hydrology in the eastern portion of the wetland is primarily maintained by shallow groundwater and precipitation that perches above a relatively impermeable layer of clay. Groundwater seeps are also found along the northern arm and in the southwest portion of the wetland. Soils in these wetland areas are typically saturated to the surface during the fall, winter, and spring months.

5.3.1.7 Mitigation Design

Tyee Valley Wetland Mitigation

The design for the wetland mitigation site is to plant a minimum of 4.5 acres of the golf course area wetland, which is currently dominated by non-native turfgrass, with native shrub species (see Figure 5.3-1; Appendix C, Sheets C2 and L1). Additionally, approximately 1.6 acres of upland area adjacent to the wetland will be planted with native shrub species

Clearing and Site Preparation

The design for the wetland mitigation site does not include significant changes to site topography by grading or excavation on the site. Prior to installing plants, culverts and golf cart roads will be removed. Very minor grading may take place attendant to the removal of golf course roads and

existing culverts. Appropriate TESC measures will be installed prior to site preparation or clearing activities to protect the adjacent wetland and stream.

Expected Hydrology

The wetland enhancement area typically would be saturated to the surface during the fall, winter, and spring months. Soil saturation and wetland hydrology, which is maintained by high seasonal groundwater levels, will not be affected by the mitigation design. As discussed previously under Constraints, if the RDF is constructed, flood levels during storm events will be slightly lower than they are now.

Landscape Plan

The planting plan consists of native shrub or small tree species that tolerate water level fluctuations, tolerate saturated soils during the fall-spring months, are typically found growing in peat soils, and are unlikely to attract significant numbers of avian wildlife (see Section 5.1.2.8; Appendix C, Sheet C2 and L1). Species tolerant of such conditions include hardhack and willows (Taylor 1993). Pacific willow, Sitka willow, and hardhack commonly occur in floodplain wetlands and are tolerant of flooding and inundation for prolonged periods. Plants will be installed in patches of varying species compositions and heights to provide the mosaic of vegetation heights that is consistent with reducing hazard wildlife attractants (Port of Seattle 2000). A temporary irrigation system may be installed in the drier portions of the golf course mitigation site to provide flexibility in planting schedules and to optimize growth rates during the initial plant establishment phase. Irrigation would use municipal water purchased by the Port.

Des Moines Creek Buffers

The reach of the west branch of Des Moines Creek south of the Tyee Valley Golf Course wetland mitigation site will be enhanced by planting native riparian trees and shrubs along both banks of the stream (Appendix C, Sheet C2). The riparian buffers¹⁰ will extend 100 ft from the OHWM of the stream. Buffer plants will include black cottonwood, red alder, western red cedar, vine maple, and Nootka rose.

A temporary irrigation system will be installed in the Des Moines Creek buffer to provide flexibility in planting schedules and to optimize growth rates during the initial plant establishment phase. Irrigation would use municipal water purchased by the Port.

5.3.1.8 Performance Standard and Contingency

Performance standards, variables to be evaluated (e.g., survival, cover) and specific contingency measures for Des Moines Creek projects are included in Table 5.3-2 and the monitoring schedule is presented in Table 5.3-3.

¹⁰ A buffer area will be designated around the Tyee Pond (Appendix C); however, no enhancement or mitigation credit is sought for this area.

Table 5.3-2. Final Performance Standards, Evaluation Approach, and Contingency Measures the Tyee Valley Golf Course and Des Moines Creek Buffer Mitigation Projects.

Design Criteria	Performance Standard	Evaluation Approach	Contingency Measures ¹
Plant 5.5 acres of the golf course wetland with native wetland shrub species includes wetland area on left and right branch Des Moines Creek.	Shrub wetland vegetation will be planted on 5.5 acres of golf course. Upland shrub vegetation will occur in about 1.57 acres of buffer.	Verify area requirements with record drawings	Plant additional areas if as-built conditions are not consistent with design
Shrub and small trees planted density greater than 3,375 stems per acre	Soils will be saturated within 10 inches of the surface (for at least 2 weeks during the growing season) in years of normal rainfall. Average survival of planted stock will be at least 80% in the first 3 monitoring years. Canopy cover of native species will be at least 80% by monitoring year 10. Canopy cover of non-native invasive species will be no more than 10% by monitoring year 10.	Monitor depth and duration of soil saturation. Vegetation sampling (plots, transects, or plotless techniques) to estimate mortality, cover, density, and presence of invasive species. See above.	Wetland hydrology currently exists on this site, and no changes are likely. Modify surface drainage features If standards are not met: <ul style="list-style-type: none"> Select species that are better adapted to existing hydrologic conditions. Install additional plant material. Install protective collars to reduce herbivore damage. See above.
Plant are with woody vegetation to discourage use of wetland by waterfowl.	Woody vegetation will provide 80% to 100% cover in the wetland mitigation area. No emergent wetland areas will be present occur on the mitigation site.	See above.	See above.
Plant 100-ft-wide riparian buffers on each side of Des Moines Creek (approximately 3.38 acres of buffer area).	Designated buffers will total about 3.38 acres and will be outside the location of preferred alternatives for SR 509, South Access Freeway, and RDF construction.	Record drawings and review of planning documents. See above.	Redesign buffer design drawing. See above.
Plant native riparian forested and shrub plant species within the 100-ft buffer along Des Moines Creek.	Average survival of planted stock will be at least 80% in the first 3 monitoring years. At this time, tree density will be at least 280 stems per acre and shrub density will be at least 2,100 individuals per acre. By the end of year 3, plant diversity in each stratum will not decrease by more than 10% from the number and type of plants installed at baseline. Tree and shrub canopy cover will be at least 80% by monitoring year 10. Cover of non-native invasive species will not be more than 10% at monitoring year 10.	See above.	See above.

¹ For all performance standards, monitoring periods may be extended if performance standards are not met.

Table 5.3-3. Monitoring schedule for Des Moines Creek Basin Mitigation Projects.

Feature	Activity	Duration	Data Collection Year																	
			0	1	2	3	4	5	6	7	8	9	10							
Hydrology	Permanent shallow-groundwater measurements will be installed in the planting area.	Monthly for the first three years;	X	X	X	X														
		Semi-monthly thereafter						X	X	X	X	X	X	X	X	X	X	X	X	X
Vegetation	Measure plant survival	Late spring or early summer	X	X	X	X														
		Vegetation sampling to determine cover	X	X	X	X														

5.3.1.9 Implementation of Des Moines Creek Projects

The Tyee wetland mitigation and Des Moines Creek buffer enhancements will be coordinated with construction of the RDF. The Port will protect the mitigation sites from RDF construction impacts by placing TESC measures and orange barrier fencing at the edge of the mitigation sites. Ecology blocks will be used to further protect the mitigation sites from RDF construction impacts. Inspections will take place throughout the mitigation construction period to ensure that plans are being implemented as specified, permit conditions are met, and BMPs are installed and operating properly.

A proposed implementation plan for Tyee Wetland Mitigation and Des Moines Creek buffer commencements are presented in Table 5.3-4. Plants in both the wetland mitigation and riparian buffer projects will be installed to reduce hazard wildlife attractants. A landscape architect or wetland scientist will observe plant installation to ensure that plants are installed correctly and according to the plans and specifications.

Plant material used in the mitigation will be obtained from commercial nurseries. Nurseries will be required to certify that the plant material is legally procured and from the appropriate geographic source. The appropriate geographic source for plant material used in the mitigation is defined as the area that is bounded on the north by the Fraser River Valley, B.C.; on the east by the 1,000-foot elevation of the Cascades; on the west by the 1,000-foot elevation in the Olympic or Coast ranges; and on the south by the Willamette Valley.

5.3.1.10 Construction Steps

General Conditions

- On award of the contract, the contractor will provide the Port with any required pre-construction submittals, work plans, and schedules.
- A pre-construction meeting will be held with the contractor, architect/engineer, and wetland scientist to review submittals, work plans, schedules, and permit conditions.
- The contractor will be responsible for ensuring that the work is performed in compliance with all permit conditions and shall maintain a copy of permits on-site.
- Work will be coordinated to avoid re-entry and damage to areas that have previously been planted; work will be conducted so that no other work will impact completed landscape work.
- Areas where any landscape work has been completed will be off-limits to all vehicular traffic, and pedestrian traffic will be strictly limited.

Plant procurement shall be completed 6 to 12 months prior to the scheduled planting season to ensure that plants are available in the quantities and species required by the planting plan.

Table 5.3-4. Proposed Implementation Timeline for Tyee Valley Golf Course and Des Moines Creek Buffer Projects.

Project/Activity	Year (Year One Starts with the First Construction Season After the Date Permits Are Issued ¹)																							
	Year 1				Year 2				Year 3															
	J	F	M	A	M	J	J	A	S	O	N	D	J	F	M	A	M	J	J	A	S	O	N	D
Tyee Valley Golf Course and Des Moines Creek Buffers																								
Preconstruction meeting																								
TESC, Site Preparation																								
Conduct minor site grading as necessary per plans																								
Install plants per planting plan																								
Produce record drawings																								
Conduct baseline monitoring																								
Begin maintenance and compliance monitoring																								

¹ Plant procurement for all projects will be implemented six to twelve months prior to the anticipated planting date to ensure that plants in the specified quantities and species are available by the scheduled planting date. Implementing mitigation projects may vary from this proposed schedule depending upon coordination with other MPU projects and contract obligations.

Pre-construction Meeting and Site Preparation

- Establish vertical and horizontal site controls and maintain through construction to record drawings.
- Identify and flag limits of work for mitigation site.
- Identify staging areas, stockpile areas, and temporary access/haul roads.
- Implement TESC plan and install TESC measures.
- Install orange barrier fencing around the site and any vegetation to be protected.
- Install fencing and TESC measures around wetlands to be avoided in borrow areas.
- Maintain security of site through construction.
- Implement a spill control plan and identify fueling areas if needed.

Clearing, Excavation, and Grading

- Clear roads and/or culverts from the wetland mitigation site; clear and grub the riparian buffer site.
- Install hydrology monitoring wells at the wetland mitigation site.
- Prepare grading record drawings; modify planting plans as needed to match as-built grades and site conditions.

Irrigation and Landscaping

- Install and test irrigation (irrigation will be designed for the wetland mitigation and buffers; however it may not be needed at the wetland mitigation site).
- Apply hydroseed to any areas of exposed soils.
- Winterize the irrigation system.
- Plant shrub wetland and forested buffer vegetation in fall/winter following grading.
- Place sterile organic mulch (e.g., wood fiber) 4 to 6 inches deep between planted stock as a weed barrier.

Closeout

- Complete site cleanup by removing temporary haul/access roads and staging areas.
- Remove construction equipment and debris.
- Hydroseed and/or install plants in temporary staging areas or access roads within the mitigation site boundaries.
- Hydroseed erosion control mix in temporary staging areas/access roads outside the mitigation boundaries.
- Install permanent fence and/or signs along mitigation site boundary.
- Install barrier fencing, rock gabions, or ecology blocks at the mitigation site boundary if necessary to protect the site from RDF construction activities.

Record Drawings, Monitoring, and Maintenance

- Produce grading and planting record drawings (i.e., 'as-builts') for wetland mitigation site and riparian buffers.
- Complete a baseline report, including record drawings and final monitoring plan (e.g., locations of monitoring plots, baseline conditions), for the wetland site, riparian buffers, and borrow areas.
- Begin compliance monitoring during first growing season after planting (or excavation for borrow areas) is complete; submit annual monitoring reports for 10-year monitoring period.
- Conduct maintenance (e.g., weed management, WHMP) and implement any necessary contingency measures to meet performance standards.

5.3.1.11 Monitoring and Performance Standards

Monitoring for the Des Moines Creek projects will be performed consistent with the approach, methods, and schedule outlined in Chapter 4 of this report. The focus of monitoring for the Des Moines Creek basin mitigation projects will be to:

- Evaluate the establishment of native wetland and riparian vegetation in the Tyee Valley Golf Course wetland and the Des Moines Creek buffers.
- Monitor groundwater and surface water levels at the Tyee Valley Golf Course wetland mitigation site.

Hydrology, vegetation and hazard wildlife monitoring will be conducted consistent with the approach and methods described in Chapter 4. Groundwater monitoring will be conducted on the Tyee Valley Golf Course mitigation site to evaluate seasonal variation in groundwater levels on the site.

Hydrologic Monitoring

A series of permanent shallow-groundwater monitoring wells will be installed in the enhanced wetland area at the Tyee Valley Golf Course to evaluate seasonal variation in groundwater levels on the site. Groundwater levels will be recorded monthly for the first 5 years of the mitigation and every other month thereafter. The exact number and location of the wells will be determined after location of the enhancement area has been established. Wells will be installed by a licensed well-driller and recorded with Ecology.

Vegetation Monitoring

The plantings at the Tyee Valley Golf Course wetland mitigation site and within the Des Moines Creek riparian buffer will be monitored over a minimum 10-year period that begins when plant installation is complete. Monitoring activities will take place n years 0, 1, 2, 3, 5, 7, 9, and 10 to determine species composition, survivorship, height, percent cover, density, and general health and vigor (see Table 5.3-3). Specific performance standards, parameters to measure and contingency measures for the Des Moines Creek projects are given in Table 5.3-2. Vegetaion monitoring will follow standard vegetaion sampling protocols as described in Chapter 4.

Wildlife Monitoring

The Port will perform wildlife monitoring in the wetland enhancement area according to requirements of the Wildlife Hazard Management Plan (Port of Seattle 2000). Based on the results of the wildlife monitoring, alterations to vegetation or hydrologic conditions may be necessary to comply with FAA requirements and the Wildlife Hazard Management Plan.

5.3.1.12 Site Protection

The Port will execute and file a restrictive covenant for the Des Moines Creek mitigation area. Copies of proposed restrictive covenants are included in Appendix G.

5.3.1.13 Maintenance and Contingency Plan

Routine maintenance tasks (e.g., maintaining irrigation system, removing trash) and adaptive management/contingency measures (e.g., weed management, re-placing plants) will be required during the monitoring period. Routine maintenance and contingency measures will be implemented consistent with the approach described in Chapter 4. Specific contingency actions for each wetland and riparian buffer performance standard are given in Table 5.3-2.

5.3.2 Des Moines Creek Basin Trust Fund for Watershed Rehabilitation

The Port will establish a trust fund for watershed rehabilitation projects in the Des Moines Creek basin in direct response to requests by the public and agencies to implement additional mitigation actions that would enhance stream and aquatic habitat throughout the Des Moines Creek watersheds. The trust fund would focus on portions of Des Moines Creek not owned by the Port. The Port is committed to making the funds available and deferring to other governmental agencies and interested groups in the selection of appropriate projects.

5.3.2.1 Goals

The goal of this mitigation action is to enhance instream or riparian habitat for salmonids and other aquatic organisms of Des Moines Creeks on land not owned by the Port.

5.3.2.2 Description

The trust fund for watershed restoration provides \$150,000 for restoration projects in the Des Moines Creek basin. Project information for potential projects eligible for funding by the trust fund is based on information provided in the Des Moines Creek Basin Plan (Des Moines Creek Basin Committee 1997) (Table 5.3-5). The trust fund would be established by the Port to fund watershed projects that result in direct habitat benefits to aquatic life in the streams or to remove documented water quality impacts.

Examples of projects eligible for full or partial funding could include instream fisheries habitat improvements (e.g., see Figures 5.2-8 through 5.2-11) riparian buffer enhancement, removal of fish passage barriers, and removal of failed septic systems. Additional planning and engineering of selected projects would result in specific project designs, performance standards, monitoring requirements, and contingency measures.

The trust fund would have a sunset clause of 2 years following issuance of MPU permits. If after a 2-year period projects are not designed and permits have not been sought,¹¹ the Port would use the money to implement those project(s) identified in the Des Moines Creek Basin Plan that provide water quality or aquatic habitat benefits. Project proponents will be responsible for obtaining any federal, state, and local permits required to implement the projects. The project(s) to be implemented would be at the discretion of the Port, but with approval from Ecology and the ACOE.

5.3.2.3 Eligibility

The Port, or designated administrator, will consider requests for monies from the watershed trust fund to implement stream habitat enhancement projects. Requests must be made by King County, the cities of SeaTac or Des Moines, tribal governments, non-profit organizations, or combinations of such governments through interlocal agreements. Organizations requesting funding must comply with general liability insurance requirements established by the Port.

Key criteria to be used in evaluating proposals to implement projects in Table 5.3-5, as well as other projects within the watershed include the following:

- A demonstrated benefit to salmon or aquatic habitat without creating significant avian wildlife habitat within 10,000 ft of runways at STIA
- Consistency with watershed management plans, or with prescriptions/recommendations identified using watershed analysis or stream assessment procedures
- Clearly defined project goals, implementation plans, performance standards, and post-project monitoring
- Preference for resolving underlying causes of problems rather than treating symptoms
- Cost-effectiveness

5.3.2.4 Implementation

The Des Moines Creek Basin Committee, the King County Watershed Coordinator, or other responsible entity would administer the fund. The administrator would establish eligible project criteria, application forms, project cost limits, implementation and monitoring requirements, etc.

5.3.2.5 Site Protection

Areas located within property owned by the Port, specifically within Des Moines Creek watershed, would be protected in perpetuity and development actions restricted. Site protection of enhancement projects would be coordinated with property owners and the fund administrator.

¹¹ The project proponents will be responsible for obtaining federal, state, and local permits required to implement the projects.

Table S.3-5. Summary of potential trust fund projects in the Des Moines Creek watershed (projects are as described in the Des Moines Creek Basin Plan, 1997).

Project	Goals	Description	Performance Standards	Monitoring	Cost Estimate ¹
Habitat Improvements					
Ravine reach ² (River Mile [RM] 1.0-1.85)	Stabilize steep channel. Provide channel geometry that responds positively to predicted flows.	Construct 20 rock weirs throughout the reach.	Rock weirs remain secure/intact for 10 years.	Assess function and any movement of rock weirs once a year at end of wet season.	\$50,000
Treatment plant ² (RM 0.4-1.0)	Provide pool habitat. Increase channel complexity. Reduce the risk of bank failure adjacent to sewer line access road by diverting high-velocity flows away from road.	Place 4 LWD complexes (4 to 6 logs each) on outside bends and/or channel spanning; install 15 small rock deflectors, each spanning 40% of channel (half immediately upstream of LWD complexes, half in high-velocity areas diverting flow from bank); place five small groups (3 to 5 rocks per group) of fish and turning rocks.	LWD complexes, rock deflectors, fish and turning rocks remain secure/intact for 10 years.	Assess functions of LWD complex, rock deflectors, fish and turning rocks; document shifting or accumulation of debris once a year at end of wet season.	\$130,000
Park reach ² (RM 0.0-0.4)	Increase pool habitat. Increase channel complexity.	Place one LWD complex (4 to 6 logs) on outside bend and/or channel spanning; install four small rock deflectors each spanning 40% of channel (half immediately upstream of LWD complexes, half in high-velocity areas diverting flow from bank); install one small group (3 to 5 rocks) of fish and turning rocks.	LWD complexes, rock deflectors, fish and turning rocks remain secure/intact for 10 years.	Assess function of LWD complexes, rock deflectors, fish and turning rocks; document shifting or accumulation of debris once a year at end of wet season.	\$50,000
Wetland reach (RM 1.85-2.15)	Maintain/enhance natural flood storage function of wetland system.	Add woody debris to stream and/or buffer.	Installed habitat features remain secure/intact instream channel for 10 years.	Assess functions of installed habitat features; document shifting or accumulation of debris once a year at end of wet season.	\$10,000
Septic systems¹					
	Reduce fecal coliform levels and improve other water quality parameters in Des Moines Creek.	Identify houses within areas not connected to sanitary sewer. Connect chronic septic system problems to sewer lines.	Identified houses are connected to sewers and septic systems are decommissioned.	As-built monitoring to verify completion.	\$ 150,000

¹ This cost estimate reflects 1997 dollars.

² Identified as "regional high priority" in the basin plan.

5.3.2.6 Monitoring and Contingency

The fund administrator would review project design, implementation, and as-built plans to verify that intended project had been built. Contingency actions associated with establishment or operation of the fund will be reviewed with the Port, ACOE, Ecology, and the fund administrator.

5.3.3 Indirect Impacts to Borrow Area Wetland Hydrology

Borrow Areas 1 and 3 will be excavated to provide fill material for the third runway and embankment construction (see Figure 4.1-2). Borrow area excavations have been designed to the extent practicable to avoid direct impacts to wetlands. Hydrological studies conducted by Hart-Crowser (Hart Crowser 2000a, 2000b) indicate that the potential for indirect impacts to the hydrology of wetlands near the borrow areas is low. To avoid and minimize potential indirect impacts, the borrow areas will be graded to provide drainage systems to collect surface runoff and/or groundwater seepage and direct this water to the wetlands.

Following construction, groundwater levels will be monitored in wetlands near the borrow areas to verify that wetland hydrology is present and able to maintain existing vegetation (Table 5.3-6). Actions taken to avoid, minimize, and mitigate for potential indirect impacts to wetland hydrology adjacent to the borrow areas are not included in the calculation of mitigation credit for the MPU projects.

5.3.3.1 Borrow Area Site Description

The borrow areas are located south of the airfield between 24th Avenue South and 15th Avenue South, and between South 200th Street and South 216th Street (see Figure 1.3-1). Most of this area was formerly residential neighborhoods. Between 5 and 20 years ago, the area was acquired and cleared as part of STLA's noise abatement program.

Borrow Area 1 is located to the east of Des Moines Creek. The area slopes toward Des Moines Creek. Nine wetlands are located in Borrow Area 1 (Wetlands B1, B4, B11, B12, B14, B15a, B15b, 32 and 48).

Borrow Area 3 is located to the west of Des Moines Creek. The borrow area is bordered on the west by a relatively level plateau that slopes steeply down to a series of depressions in the southeast portion of the borrow area (Appendix G, Figure 1). The northern half and the western edge of the borrow area are high points approximately 40 ft to 120 ft higher than the low point in the southeast corner. Eight wetlands occur in Borrow Area 3 (Wetlands B5, B6, B7, B9a, B9b, B10, 29, and 30).

5.3.3.2 Hydrology of Borrow Area Wetlands

Borrow Area 1 contains both groundwater dominated and precipitation dominated wetlands. Wetlands B1, B11, B14, and 32 are depression wetlands maintained by precipitation and surface water runoff. Wetlands B4, B12, B15 and 48 are slope wetlands maintained by groundwater seepage. Water surfacing in these slope wetlands flows downslope to Des Moines Creek. Surface water hydrology in the general vicinity of Borrow Area 1 has been altered by the system of storm drains, culverts, and drainage ditches constructed when the area was developed. Since clearing of

Table 5.3-6. Final Performance Standards, Evaluation Approach, and Contingency Measures for Monitoring Borrow Area Wetlands.

Design Criteria	Performance Standard	Evaluation Approach	Contingency Measures¹
Maintain wetland hydrology by redirecting surface water runoff to the wetlands near Borrow Area 1.	Soils in Wetlands near Borrow Area 1 (48, B15a, 15b) will have soils saturated to the surface from December to March or April in years of normal rainfall.	Shallow groundwater monitoring wells	Minor regrading to direct surface water runoff to wetlands
Maintain wetland hydrology by directing groundwater seepage and surface water runoff via an interceptor swale to wetlands in and near Borrow Area 3.	Soils in Wetland 30 will be saturated to the surface from December to May in years of normal rainfall. Wetland 30 will have shallow standing water during the breeding season for resident amphibians (i.e., December to April).	Shallow groundwater monitoring wells	Adjust length and discharge points of interceptor swale system
	Wetland 29 will have soils saturated to the surface from December to April in years of normal rainfall.	Shallow groundwater monitoring wells	Adjust length and discharge points of interceptor swale system

¹ For all performance standards, monitoring periods may be extended if performance standards are not met.

the area for the noise abatement program, these surface drainage features have been abandoned and begun to deteriorate to such an extent that past drainage patterns are changing.

In Borrow Area 3, Wetland 29 occurs on the hillside at the west edge of the borrow area. Hydrology in this wetland is supported by groundwater seeps discharging on the face of the slope from a zone of perched groundwater that extends to the north and west (Hart-Crowser 2000a, b, c). Wetlands 30, B7, B6, and B5 occupy a series of depressions in the lower southeastern corner of Borrow Area 3. These wetlands may be supported by some shallow subsurface flow or interflow moving down slope from Wetland 29 (Hart-Crowser 2000c), and by precipitation. Since these wetlands occur below the main perched groundwater layer on this site the groundwater is available to support wetland hydrology. Water is held in these wetlands by the relatively impermeable soils lining the depressions, promoting shallow perched conditions (Hart-Crowser 2000c).

5.3.3.3 Actions to Avoid, Minimize, and Mitigate Indirect Impacts

Borrow Area 1

The excavation in Borrow Area 1 has been designed to avoid direct impacts to Wetlands B1, B4, B15a, B15b, 32, and 48 (see Figure 3.1-2). Indirect impacts to wetlands which are downslope of the borrow area will be minimized by not excavating portions of the borrow area that lie within the watershed of these wetlands. Hydrology in these wetlands appears to be maintained by seasonal groundwater that perches on the till soils following periods of high rainfall. The existing stormwater drainage system on 20th Avenue South collects surface runoff and directs it away from these wetlands. This stormwater drainage system forms the eastern edge of the watershed for Wetlands 48, B15a, and B15b. Since excavation will not occur west of 20th Avenue South, the watersheds of these wetlands will not be altered and indirect hydrologic impacts are not expected to occur.

Wetland hydrology will be monitored in Wetlands 48, B15a, and B15b to verify that wetland hydrology continues to be present in these wetlands (see Table 5.3-6).

Borrow Area 3

A drainage swale will be installed following excavation of Borrow Area 3 to convey groundwater to Wetland 29 and replace the potential loss of seepage from the perched groundwater zone (Appendix G, Figures 3, 7, 8). This swale will collect groundwater seepage from the excavated slope face on the north and west sides of Borrow Area 3. Flow in this swale will be collected and conveyed south in a swale that drains into Wetland 29 (Appendix G, Figure 3).

Since the swale will extend for the full length of the seepage face in the borrow area, it may convey flows in excess of those needed to support hydrology in Wetland 29 and downslope wetlands (i.e., Wetland 30 which receives overland flow and shallow interflow from Wetland 29). To manage excess flows and to optimize the distribution of water to Wetland 29, two measures will be used. A flow control structure (weir and diversion structure) will be constructed in the swale just before it flows into Wetland 29 (Appendix G, Figure 9). This control structure will allow a controlled flow rate to be directed into Wetland 29 and enable diversion of other flows away from the wetland and into the base of Borrow Area 3. Diverted flows will either be allowed to infiltrate at the base of

Borrow Area 3 or be diverted to stormwater management facilities that will be constructed to manage runoff from the remainder of the borrow area. The length of the collector swale can also be modified (consistent with the adaptive management approach) based on post-construction monitoring to control the amount of seepage and runoff that is collected in the swale and diverted to Wetland 29.

Studies of borrow area hydrology indicate that impacts to the hydrology of the remaining wetlands in Borrow Area 3 (B5, B6, B7, B9a, B9b, B10, and 30) are not anticipated (Hart Crowser 2000a, b, c). Wetlands in Borrow Area 3 will be monitored before, during, and after excavation to verify that wetland hydrology will remain. If Wetlands 29 and 30 do not meet hydrologic performance standards developed for them (see Table 5.3-6), then contingency measures will be implemented. The collector swale system also can be used to divert additional water to Wetlands 29 if necessary.

5.3.3.4 Hydrology Monitoring

Permanent shallow groundwater monitoring wells will also be installed in wetlands near borrow areas to verify there are no indirect hydrologic impacts. Groundwater levels will be recorded monthly for the first 5 years, and then every other month thereafter. In addition, a staff gage will be installed in Wetland 30 to allow monitoring of the extent and duration of surface water ponding that provides habitat for amphibians. Surface water levels will be recorded monthly for the 5 five years, and then every other month thereafter.

6. HYDROLOGIC IMPACTS AND MITIGATION

This chapter describes actions incorporated into the STIA Master Plan Update improvements to mitigate potential impacts to water quantity and quality in the Miller, Walker, and Des Moines Creek basins. Existing water quantity and quality conditions, future changes in land use that affect surface water runoff, and projected future conditions under the Master Plan Update improvements and the proposed mitigation actions are summarized in this chapter.

Section 6.1 describes the proposed stormwater management program to control stormwater peak flow rates and flow durations from both newly developed project areas and existing airport areas. Proposed facilities, including approximately 319.2 acre-ft of new stormwater detention storage at 14 locations, will mitigate the impacts of new impervious surfaces on flows in Miller, Walker, and Des Moines Creeks. Section 6.2 summarizes actions to mitigate water quality impacts, including water quality treatment using BMPs and source controls, erosion and sediment control, and elimination of existing activities that degrade water quality. The flow control and water quality mitigation activities summarized below are based on stormwater information provided in the *Comprehensive Stormwater Management Plan (SMP)* (Parametrix 2000a).

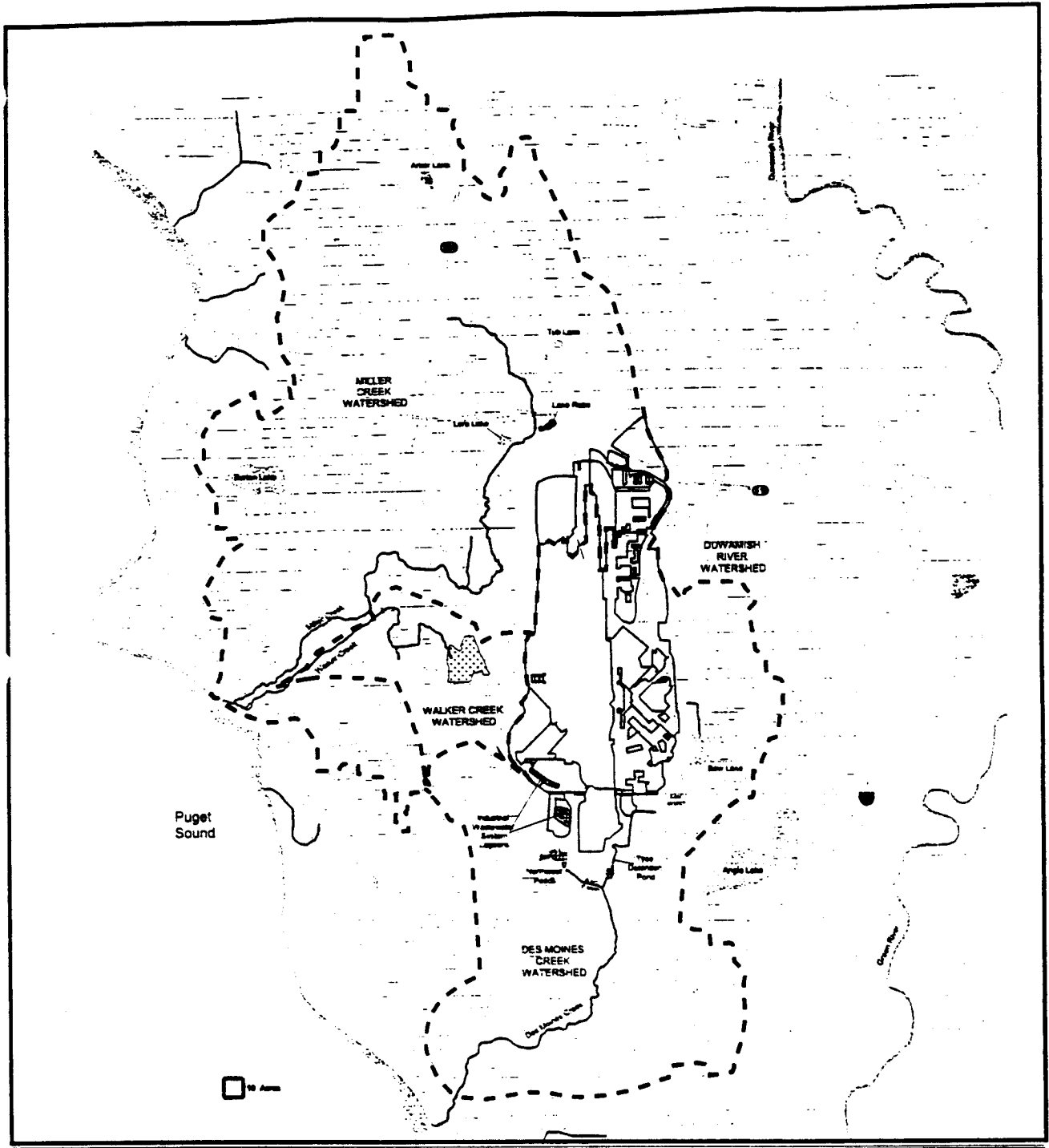
6.1 WATER QUANTITY

The Master Plan Update improvements could increase peak flows and reduce base flows in Miller, Walker, and Des Moines Creeks (Figure 6.1-1), thereby impacting aquatic habitat in these streams. The addition of new impervious area associated with the Master Plan Update improvements affecting the hydrology of these streams is discussed in the following sections, along with associated mitigation measures that compensate for these actions.

6.1.1 Stormflow Impacts

The activities associated with the Master Plan Update improvements will include adding new impervious surfaces (new runways, taxiways, parking, and roadways) and filling wetlands. This action, if unmitigated, could change the hydrologic flow regime of Miller, Walker, and Des Moines Creeks, including increased peak flow magnitude and frequency, and increased elevated flow duration. The potential effects of high-flow impacts in the stream are increased erosion and sedimentation, habitat damage from scouring flows, and impaired habitat use during high-flow periods.

Proposed peak flow mitigation reduces peak flows from existing levels in both streams, which will reduce bank and channel erosion as well as sedimentation in downstream reaches, including estuaries. Additional detail on hydrology and stormwater management are provided in the SMP (Parametrix 2000a). The plan includes modeling conducted to estimate the impacts of the project on the Miller, Walker, and Des Moines Creek systems. The Hydrologic Simulation Program – FORTRAN (HSPF) model was used for this purpose.



Prepared by: **AR 048828**
 Source: Based on King County data. Water bodies derived from 1:50,000 topographic data. Watershed boundaries are computer-generated. Watershed boundaries shown on this map are for descriptive and planning only. EPA delineates waters based on 1:250,000 scale.



- Roads
- ▨ Constructed Water Features
- Watershed Boundary
- Rivers
- ◻ Water Bodies

Figure 6.1-1
Miller, Walker,
and Des Moines
Creek Watersheds

6.1.1.1 Wetland Fill

The potential impacts to the hydrology of Miller, Des Moines, and Walker Creeks from filling 18.37 acres of wetlands are the loss of stormwater storage, groundwater recharge, and groundwater discharge. These functions are discussed below, and all wetland hydrologic functions are accounted for in the HSPF model, which assesses runoff impacts by various input parameters and calibration.

Stormwater Storage

Most wetlands filled by the project provide limited stormwater storage because the wetlands do not occur in closed basins or basins with restricted outlets that would allow water to pond during storms, and release water slowly following storms. Most wetlands occur on moderate to gentle slopes and are free-draining (seldom, if ever, ponding water).

In contrast, flood storage functions are provided by the riparian wetlands located in the 100-year floodplain of Miller Creek. Approximately 8,455 cy of flood storage would be filled at Vacca Farm, and approximately 9,589 cy of new floodplain will be excavated adjacent to the stream. All flood storage, including that provided by wetlands, is accounted for in the calibration of the HSPF model; design of stormwater detention facilities using this model will assure that flow mitigation is provided to account for impacted wetlands.

Groundwater Discharge

Several wetlands are sites of groundwater discharge, and thereby potentially provide base flow support to streams during all or portions of the year. Where fill occurs in these wetlands, the project has been designed to allow these discharge functions to continue. For example, the third runway embankment is designed with an internal drainage system that will collect water that currently infiltrates on the airfield and discharges in wetlands near 12th Avenue South. The drainage system will also collect water that infiltrates into the new embankment, and discharge it to wetlands and Miller Creek (see Chapter 5). Drainage systems associated with the retaining wall, which will be constructed to reduce wetland impacts, will also convey groundwater downslope to wetlands and the stream. Groundwater discharge effects on base flow are accounted for in the calibration of the HSPF model.

Groundwater Recharge

Most wetlands affected by fill are unlikely to have significant groundwater recharge functions because most of these wetlands occur on till soils, where layers of till restrict groundwater recharge. These low permeabilities result in poor drainage conditions, which in combination with topography and surface drainage features, promote the development of wetlands. Other wetlands occur in areas of known groundwater discharge (i.e., wetlands formed by local groundwater discharges) and thus cannot recharge groundwater. However, the HSPF model is based on the premise that all wetlands infiltrate; thus the model conservatively accounts for potential impacts to groundwater recharge as a result of filling these wetlands. Overall, development of impervious surfaces from Master Plan Update improvements could reduce groundwater recharge and eventual groundwater discharge to streams. These functions are accounted for in the HSPF model, and mitigation for these effects is included in the activities discussed in Chapters 5 and 7 of this document, as well as in the SMP (Parametrix 2000a).

6.1.1.2 Indirect Hydrologic Impacts/ Impact Avoidance

Where feasible and practicable, direct and indirect impacts to the hydrologic functions of wetlands (base flow, groundwater discharge, and stormwater storage) have been avoided (Parametrix 2000a,b). For example, within the three borrow areas, direct and indirect impacts to hydrologic functions of wetlands were avoided or minimized by protecting several wetlands and their upslope watersheds from excavation. Wetlands located downslope of excavation or fill areas will continue to receive ground and surface water from upslope areas because BMPs for water quality, site grading, and other surface water management features will allow clean water to continue to discharge to them. Additionally, rainwater will continue to infiltrate on the borrow sites because no impervious surface will be added, and this water will be available to recharge downslope wetlands and Des Moines Creek.

6.1.1.3 Impervious Area

In the Miller Creek Basin, Master Plan Update improvement projects will result in a net increase of 105.6 acres¹² of impervious surface area (Table 6.1-1), increasing the overall impervious area in the basin by about 1 percent above the existing baseline condition (about 23 percent of impervious surface; Parametrix 1999). In the Walker Creek Basin, Master Plan Update improvements will result in a net increase of 6.2 acres of impervious surface. In the Des Moines Creek Basin, Master Plan Update improvements will result in a net increase of 128.2 acres of impervious surface, increasing the overall impervious area in the basin by about 4 percent above the existing base condition (approximately 32 percent impervious surface; Parametrix 1999).

The new impervious surfaces could increase stormwater runoff rates (FAA 1996) and volumes. Unless mitigated, changes in runoff would be expected to increase flooding and erosion, and would degrade instream habitat and water quality in Miller, Walker, and Des Moines Creeks downstream of stormwater inputs from the improved areas. As discussed below, the Port's SMP includes mitigation to manage runoff from newly developed Master Plan Update improvement areas. In addition, existing hydrologic impacts from existing impervious surfaces will be mitigated.

¹² The net change in impervious area includes removal of approximately 50 acres of impervious surfaces (streets, driveways, and rooftops) that will result when existing houses and streets are removed in the acquisition area. Demolition in these areas is ongoing and is expected to be completed by 2002.

Table 6.1-1. Summary of Miller, Walker, and Des Moines Creek drainage areas at STIA and change in impervious area between 1994 baseline and 2006 future conditions (acres).

	1994 Baseline			2006 Future Condition			Increase in Impervious Area
	Pervious	Impervious ¹	Total	Pervious	Impervious ¹	Total	
Miller Creek							
SDN1	6.2	9.9	16.1	3.5	12.7	16.1	2.8
SDN1LWR	5.0	0.4	5.4	4.9	0.6	5.4	0.2
SDN1OFF	25.8	10.5	36.3	28.3	8.0	36.3	-2.5
SDN2X	7.2	0.3	7.5	5.3	2.2	7.5	1.9
SDN3	33.4	14.5	47.9	23.6	24.3	47.9	9.8
SDN3A	28.6	1.9	30.5	22.2	8.2	30.5	6.3
SDN3X	25.4	0.0	25.4	25.4	0.0	25.4	0.0
SDN4	27.7	2.6	30.3	18.1	12.3	30.3	9.7
SDN4X	14.1	1.1	15.2	11.0	4.2	15.2	3.1
SDW1A	52.0	0.9	52.8	37.4	15.4	52.8	14.5
SDW1B	92.5	4.3	96.9	69.9	27.0	96.9	22.7
NEPL	41.4	0.9	42.3	10.0	32.3	42.3	31.4
CARGO	7.0	1.1	8.1	0.0	8.1	8.1	7.0
Other STIA ²	246.5	15.1	261.8	247.8	13.8	261.8	-1.3
Total							105.6
Walker Creek							
SDW2	41.3	3.3	44.6	35.1	9.5	44.6	6.2
M8	22.2	6.6	28.8	22.2	6.6	28.8	0.0
M9	76.1	22.5	98.6	76.1	22.5	98.6	0.0
Total							6.2
Des Moines Creek							
SDE4	50.7	115.5	166.2	40.1	126.1	166.2	10.6
SDS1	0.9	16.8	17.7	1.4	16.3	17.7	-0.5
SDS2	7.7	1.5	9.2	8.1	1.0	9.2	-0.5
SDS3	165.5	178.0	343.5	144.3	199.2	343.5	21.2
SDS3A	62.7	7.1	69.8	34.6	35.1	69.8	28.0
SDS4	45.4	19.2	64.6	32.1	32.5	64.6	13.3
SDS5	32.1	0.4	32.5	28.3	4.2	32.5	3.8
SDS6	12.5	4.3	16.7	13.5	3.2	16.7	-1.1
SDS7	83.2	8.0	91.3	55.1	36.2	91.3	28.2
SASA	25.3	8.9	34.3	0.0	34.3	34.3	25.4
Other STIA ³	136.1	57.7	194.4	136.0	57.5	193.5	-0.2
Total							128.2
IWS							
NCPS	6.9	28.8	35.7	4.8	30.9	35.7	2.1
NSMPS	6.6	0.0	6.6	4.7	2.0	6.6	2.0
NSPS	0.3	13.5	13.8	0.3	13.4	13.8	-0.1
Primary	24.9	277.6	302.6	13.5	289.1	302.6	11.5
SASA	51.8	6.5	58.3	0.1	58.3	58.4	51.8
Total							67.3
TOTAL	1465.0	839.7	2305.8	1157.7	1147.0	2304.9	307.3

Note: Rows may not total exactly as shown due to rounding. Source: GIS coverage.

¹ Impervious area includes impervious area, lakes, and detention ponds.

² Includes subbasins M6, MC1, MC2, MC3, MC4, MC5, MC6, MC7.

³ Includes subbasins D5, D6, D11, D13.

6.1.1.4 Flow Control for New Master Plan Update Improvements and Retrofitting for Existing Airport Areas: Level 2

To protect instream and estuarine habitat, the Port has committed to achieving stream flows that maintain or reduce existing peak flow magnitude and duration in Miller and Des Moines Creeks. The Level 2 flow control standard, as defined by the King County Manual (King County DNR 1998), requires matching or improving post-developed flow duration to pre-developed flow durations¹³ for all flow magnitudes between 50 percent of the 2-year event and the full 50-year event.

The Level 2 analysis is more protective than stormwater control standards that have been used in the past. Previous controls allowed using an "event model," which is a hydrologic model that compares pre-development runoff with post-project runoff using a hypothetical design storm; only peak flows were evaluated for compliance with standards. The Level 2 analysis used in the SMP requires that a "continuous simulation" model (HSPF) be used and actual precipitation runoff is modeled. Pre-development runoff is compared with post-project flows over a range of probable flows. Level 2 flow analysis evaluates flow protection and mitigation measures over a wide range of erosive stormflows, whereas Level 1 analysis and event models are only protective of certain peak flows or flooding events. Level 2 is more protective of stream morphology, habitat (such as stream substrate), and hydrologic flow patterns.

The pre-developed condition for the Level 2 standard will be based on a *target flow regime*. The target flow regime used assumes that the existing watershed land cover is 10 percent impervious (or less if the existing impervious area is less than 10 percent impervious), 15 percent pervious "grass," and 75 percent pervious "forest."¹⁴ Basing target flow on theoretical basin development of 10 percent (Miller Creek and Des Moines Creek existing impervious areas are 23 percent and 32 percent, respectively) is expected to reduce existing peak flows and be beneficial in maintaining stable stream channels (Parametrix 1999).

In the Des Moines Creek Basin, the target flow regime was determined in a study by the University of Washington (King County CIP Design Team 1999). The flow regime determined for Des Moines Creek coincides with a target flow regime that would occur with an effective watershed impervious area of 10 percent. In studies of several Puget Sound streams, Booth and Jackson (1997) identified an approximately 10 percent impervious area threshold above which stream channel instability and habitat degradation occur.

The net result of flow retrofitting in the watersheds will be to reduce existing stormwater peak flows downstream of STIA in Miller and Des Moines Creeks *before flow impacts and controls for the Master Plan Update improvements are considered*. That is, even though the Miller Creek and Des Moines Creek watersheds have an existing impervious area of about 23 and 32 percent, respectively

¹³ Flow duration control refers to limiting the duration of geomorphically significant flows (i.e., those flows that initiate bedload movement) to baseline (pre-Master Plan Update) conditions.

¹⁴ In areas where existing impervious area is less than 10 percent, the impervious area is not changed and the difference between actual percent impervious and 10 percent is assumed to be grass.

(Parametrix 1999), the flows from areas draining the airport would be reduced to a level corresponding to approximately 10 percent impervious area.¹⁵

6.1.1.5 Estimated Detention Storage Requirements

Proposed stormwater detention facilities for the Master Plan Update improvements were designed based on the drainage area served by each facility, the detention standard, the detention storage volume required to meet the flow control standards, and potential for waterfowl attraction. Approximately 326 acre-ft of new stormwater detention storage will be needed to mitigate the impacts of increased stormwater runoff (Table 6.1-2) associated with Master Plan Update improvements. The locations of new facilities are shown in Figure 6.1-2.

For sub-watersheds draining to the Des Moines Creek RDF or the Miller Creek Detention Facility, additional future analysis by the Port or the Basin Committees may show that the target flow and Level 2 standards can be met in the regional facilities. Stormwater detention facilities shown by the Port may be modified, with approval by Ecology, to reflect using available detention in the regional facilities. In either case, the objective to meet the target flow using the Level 2 standard for both streams will be achieved.

Pond and Vault Construction and Operation

The feasibility of proposed stormwater ponds and vaults is demonstrated by the recent construction of similar facilities at STIA, including the NEPL Vault (1997) and the Interconnecting Taxiways Vault (1998). Only the SASA detention pond will displace wetlands, a 0.06-acres shrub wetland. All other on-site detention facilities will be constructed in non-wetland areas. The primary discharge from the detention facilities will be surface discharge (not infiltration). However, infiltration is proposed at two stormwater facilities, SDW1A and SDW1B, to enhance base flows and reduce detention facility size. Detention facilities will consist of dry ponds with live storage¹⁶ and will not include wet ponds with dead storage.¹⁷

Net Result of Hydrologic Mitigation

The net result of flow controls for the Master Plan Update improvements will be to maintain or reduce peak flows in Miller, Walker, and Des Moines Creeks to a stable flow regime downstream of STIA discharges (Tables 6.1-3 and 6.1-4). Stormwater facilities will retrofit existing flows to the target watershed flow regime pre-development conditions before new development is considered. The net effect of flow controls for Miller, Walker, and Des Moines Creeks (Figures 6.1-3, 6.1-4, 6.1-5, and 6.1-6) will be to maintain stormflows below existing conditions or the target watershed flow regimes following Master Plan construction and peak flow mitigation, whichever is less. The target flow regime will reduce flows in the stream channels, thereby reducing erosion and improving channel stability.

¹⁵ The HSPF model was calibrated with recorded flow data and actual basin land use prior to simulation of adding Level 2 flow control retrofits. The calibration accounts for flows attributable to each type of land use, based on existing conditions. Flows for other land use and hydrologic control conditions (such as 10 percent impervious surfaces and the Level 2 flow control retrofit) were then simulated using the HSPF model.

¹⁶ Live storage is that volume of stormwater stored in a detention facility that drains following the storm. Live storage is used for hydrologic benefit to reduce flow peaks and durations.

¹⁷ Stormwater for supplemental low stream flow may be stored as dead storage in vaults.

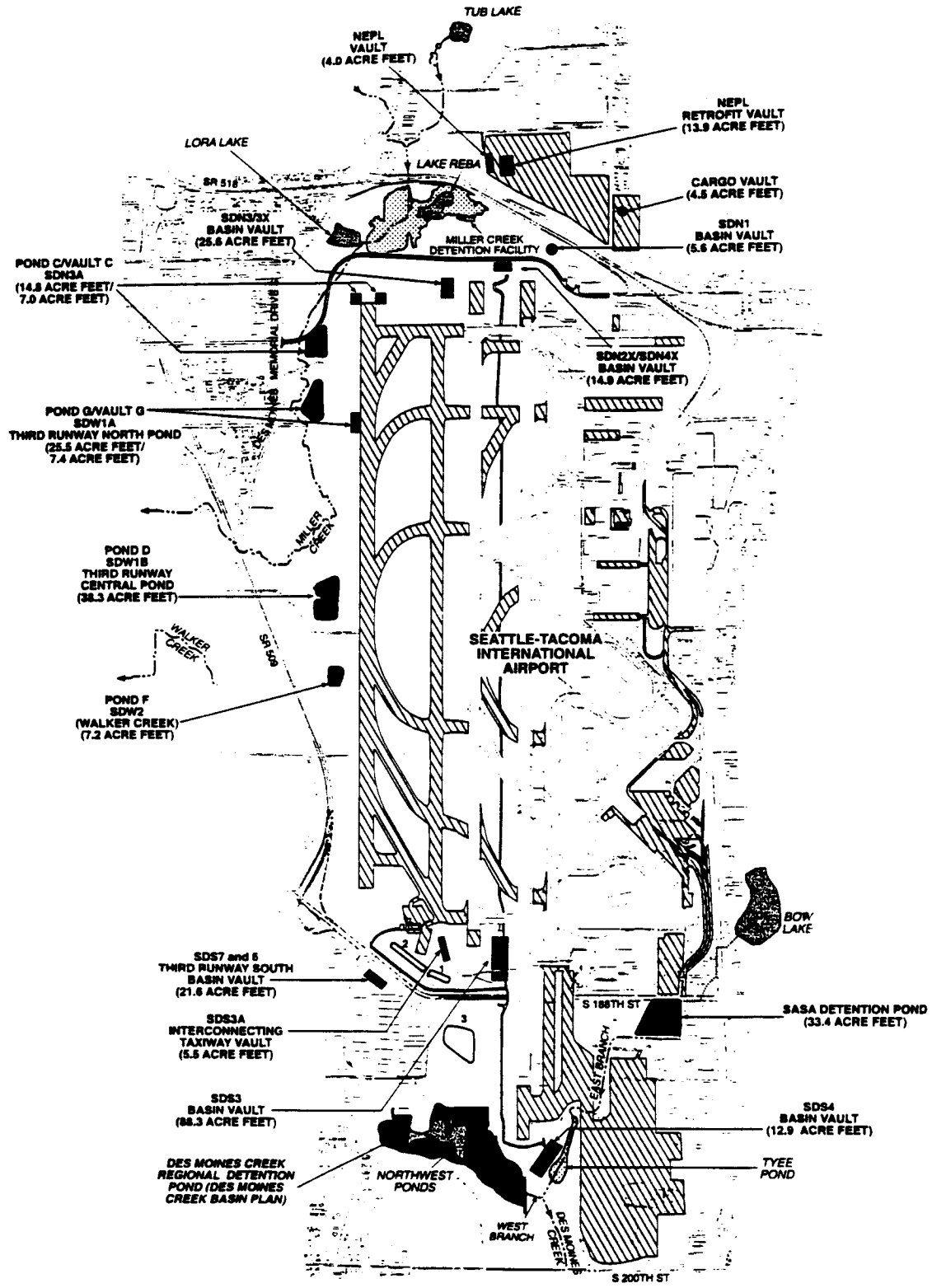
Table 6.1-2. Summary of required detention facility volumes.

Watershed	Hydrologic Evaluation Point	Volume Required (acre-ft)	Type of Facility¹	Comments
Miller Creek	NEPL	13.9 ²	Vault	In addition to existing 4 ac-ft
	CARGO	4.5	Vault	
	SDN2x + SDN4x	14.9	Vault	
	SDN3/3x	25.6	Vault	
	SDN1	5.6	Vault	
	SDN3A	Pond: 14.8 / Vault: 7.0	Pond/Vault	
	SDW1A	Pond: 25.5 / Vault: 7.4	Pond/Vault	Infiltration used
	SDW1B	38.3	Pond	Infiltration used
Total Miller Creek		157.5		
Walker Creek	SDW2	7.2	Pond	
Total Walker Creek		7.2		
Des Moines Creek	SASA Detention Facility	33.4 ³	Pond	
	Interconnecting taxiway (SDS3A)	5.5	Vault	
	Third Runway South (SDS7 and 6)	21.6	Vault	
	SDS3	88.3	Vault	
	SDS4	12.9	Vault	
Total Des Moines Creek		161.7		
Total		326.4		

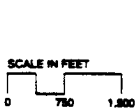
¹ Types of facilities: Vault – enclosure with multiple orifice outlets on vertical riser with overflow spillway;
Pond – open earth construction with netting or other means to provide wildlife deterrent.

² Volume needed to retrofit existing facility.

³ Retrofit STLA area only.



Part of Seattle-Tacoma International Airport Master Plan (2000-2010) (2000 (K))



- Water Features
- Proposed Stormwater Detention Facilities (With Simulated Maximum Storage Volume)
- Master Plan Projects
- Creek
- Piped Creek
- Detention Facility

Figure 6.1-2
Detention Facilities
for Master Plan Projects

Table 6.1-3. Summary of flood peak flow frequency results for Miller/Walker Creek subbasins (all values are cubic feet per second).

Return Period Peak	NEPL		CARGO		SDW2		SDW1B		SDN3A (Vacca)	
	Pre-Project	Project	Pre-Project	Project	Pre-Project	Project	Pre-Project	Project	Pre-Project	Project
1/2 Q ₂	0.61	0.22	0.12	0.05	1.65	0.58	0.68	0.20	0.27	0.09
Q ₂	1.22	0.44	0.24	0.09	3.30	1.16	1.35	0.40	0.53	0.18
Q ₁₀	1.70	0.73	0.33	0.14	6.22	3.14	2.11	0.71	0.75	0.32
Q ₂₅	1.96	0.96	0.38	0.18	7.71	5.06	2.57	1.04	0.87	0.44
Q ₅₀	2.16	1.18	0.42	0.21	8.82	7.13	2.96	1.04	0.96	0.56
Q ₁₀₀	2.37	1.46	0.46	0.25	9.92	9.95	3.39	1.89	1.05	0.70

Return Period Peak	SDW1A		SDN3, SDN3X		Combined SDN2X/SDN4/SDN4X		Miller Creek at Detention Facility	
	Pre-Project	Project	Pre-Project	Project	Pre-Project	Project	Pre-Project	Project
1/2 Q ₂	0.15	0.006	0.71	0.25	0.57	0.20	19.66	19.78
Q ₂	0.30	0.01	1.41	0.50	1.15	0.39	39.31	39.56
Q ₁₀	0.58	0.05	2.01	0.83	1.61	0.68	56.11	56.41
Q ₂₅	0.79	0.12	2.33	1.06	1.86	0.95	64.06	64.38
Q ₅₀	0.99	0.25	2.58	1.27	2.06	1.22	69.82	70.17
Q ₁₀₀	1.24	0.52	2.84	1.52	2.26	1.57	75.47	75.85

Return Period Peak	Miller Creek at SR509		Walker Creek at South 12 th Street		SDN1	
	Pre-Project	Project	Pre-Project	Project	Pre-Project	Project
1/2 Q ₂	22.81	22.72	1.65	0.58	0.28	0.12
Q ₂	45.62	45.44	3.30	1.16	0.56	0.24
Q ₁₀	67.23	65.61	6.22	3.14	0.79	0.40
Q ₂₅	77.29	74.82	7.71	5.06	0.91	0.54
Q ₅₀	84.53	81.38	8.82	7.13	1.00	0.67
Q ₁₀₀	91.58	87.72	9.92	9.95	1.10	0.82

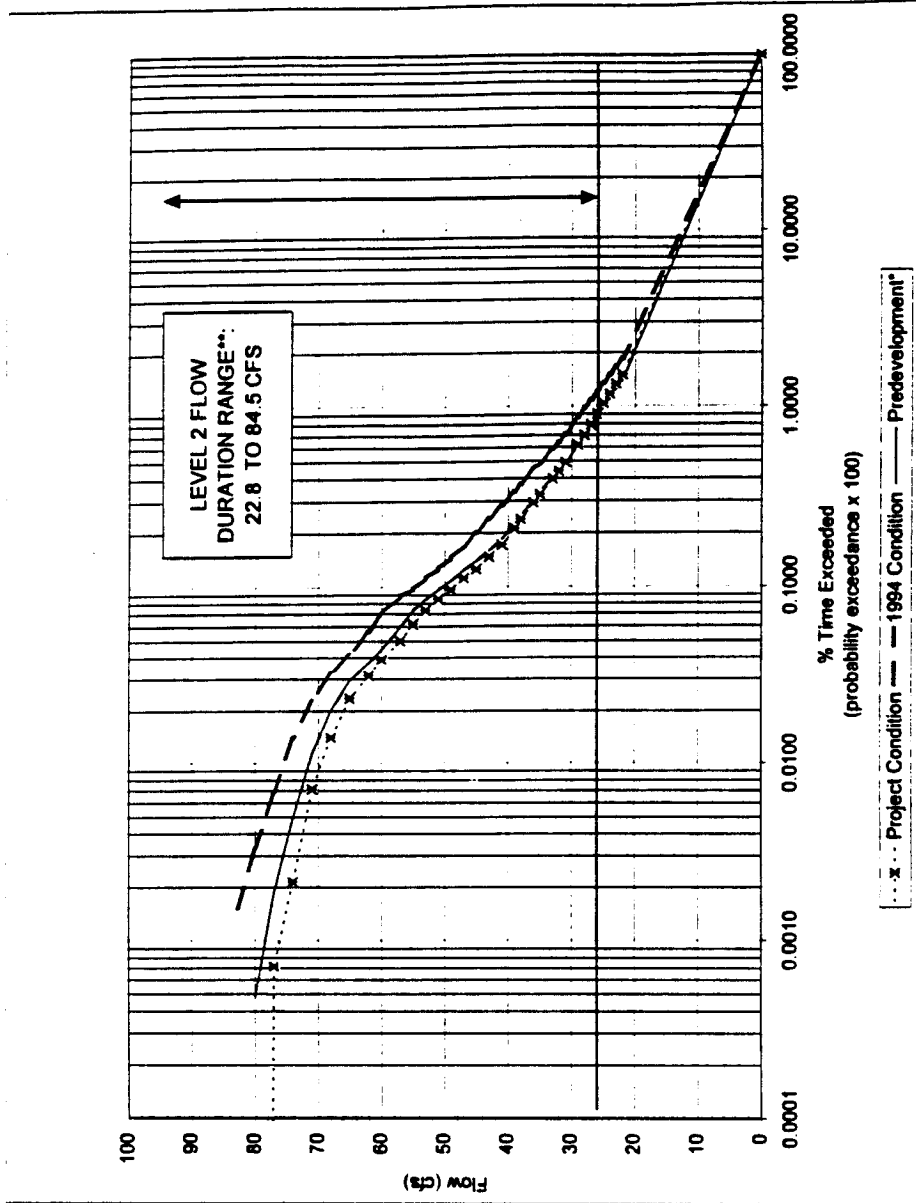
**Table 6.1-4. Summary of flood peak flow frequency results for Des Moines Creek subbasins
(all values are cubic feet per second).**

Return Period Peak	SASA ¹		SDS3		SDS3A	
	Pre-Project	Project	Pre-Project	Project	Pre-Project	Project
1/2 Q ₂	31.95	13.57	6.03	2.40	1.23	1.52
Q ₂	63.90	27.13	12.06	4.79	2.45	3.05
Q ₁₀	97.35	44.54	21.07	10.85	4.28	7.80
Q ₂₅	116.65	56.20	26.92	16.51	5.47	12.09
Q ₅₀	132.17	66.34	31.92	22.46	6.49	16.50
Q ₁₀₀	148.69	77.82	37.52	30.39	7.62	22.26

Return Period Peak	SDS4		SDS - Point of Compliance	
	Pre-Project	Project	Pre-Project	Project
1/2 Q ₂	0.86	0.35	8.06	4.35
Q ₂	1.72	0.69	16.11	8.71
Q ₁₀	2.65	1.29	28.45	18.58
Q ₂₅	3.21	1.80	36.55	26.66
Q ₅₀	3.67	2.29	43.51	34.51
Q ₁₀₀	4.17	2.92	51.33	44.30

Return Period Peak	SDS7		Des Moines Creek @ South 200 Street	
	Pre-Project	Project	Pre-Project	Project
1/2 Q ₂	1.47	0.64	55.72	36.29
Q ₂	2.94	1.28	111.45	72.58
Q ₁₀	5.23	2.84	184.86	117.11
Q ₂₅	6.73	4.45	231.02	145.08
Q ₅₀	8.03	6.25	269.81	168.55
Q ₁₀₀	9.48	8.77	312.64	194.44

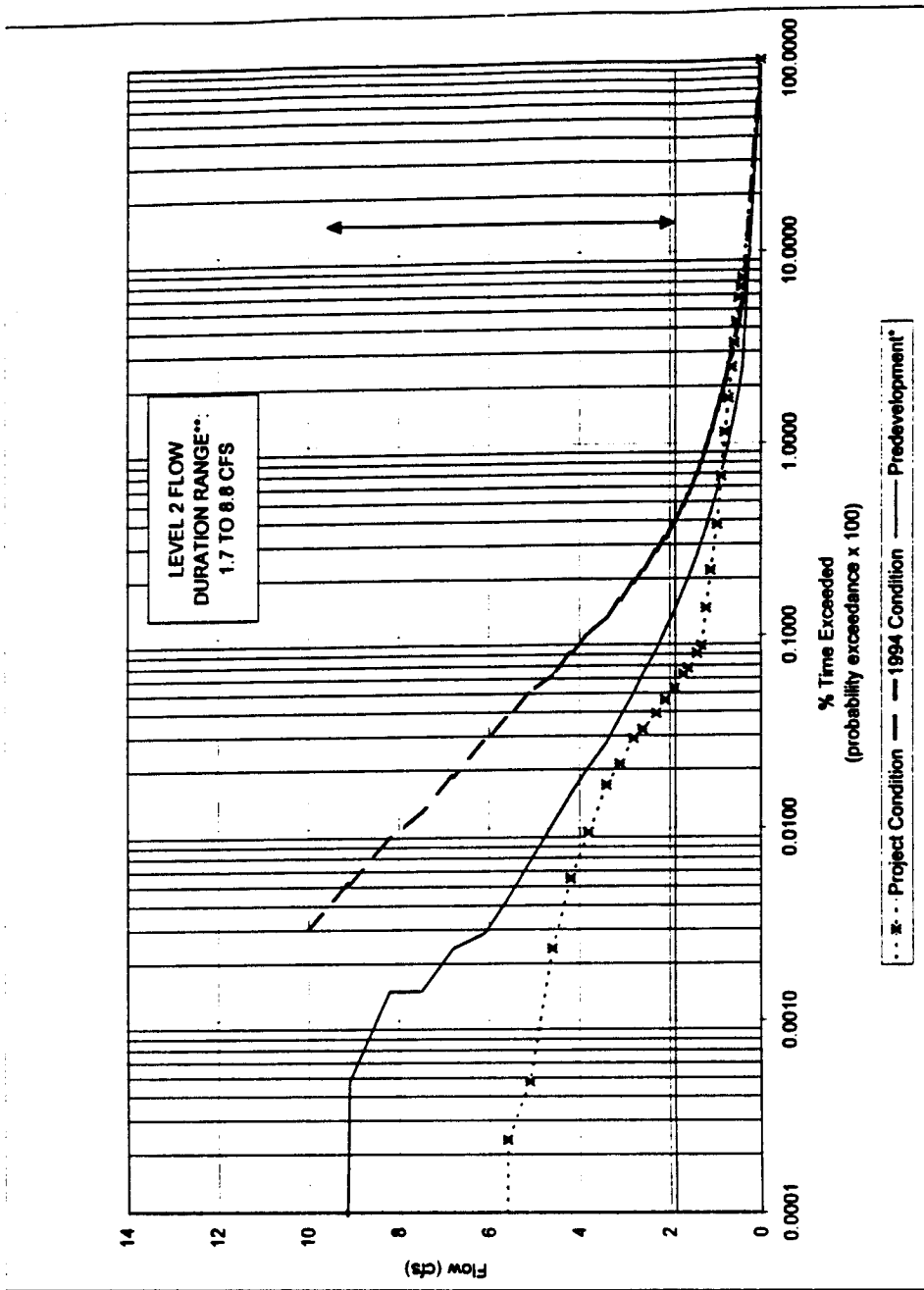
¹ STIA basins plus non-STIA basins D1 and D2 routed to pond. Retrofitting applied only to STIA drainage areas.



* Port basins use target flow regime (10-75-15). Off-site basins use 1994 conditions.

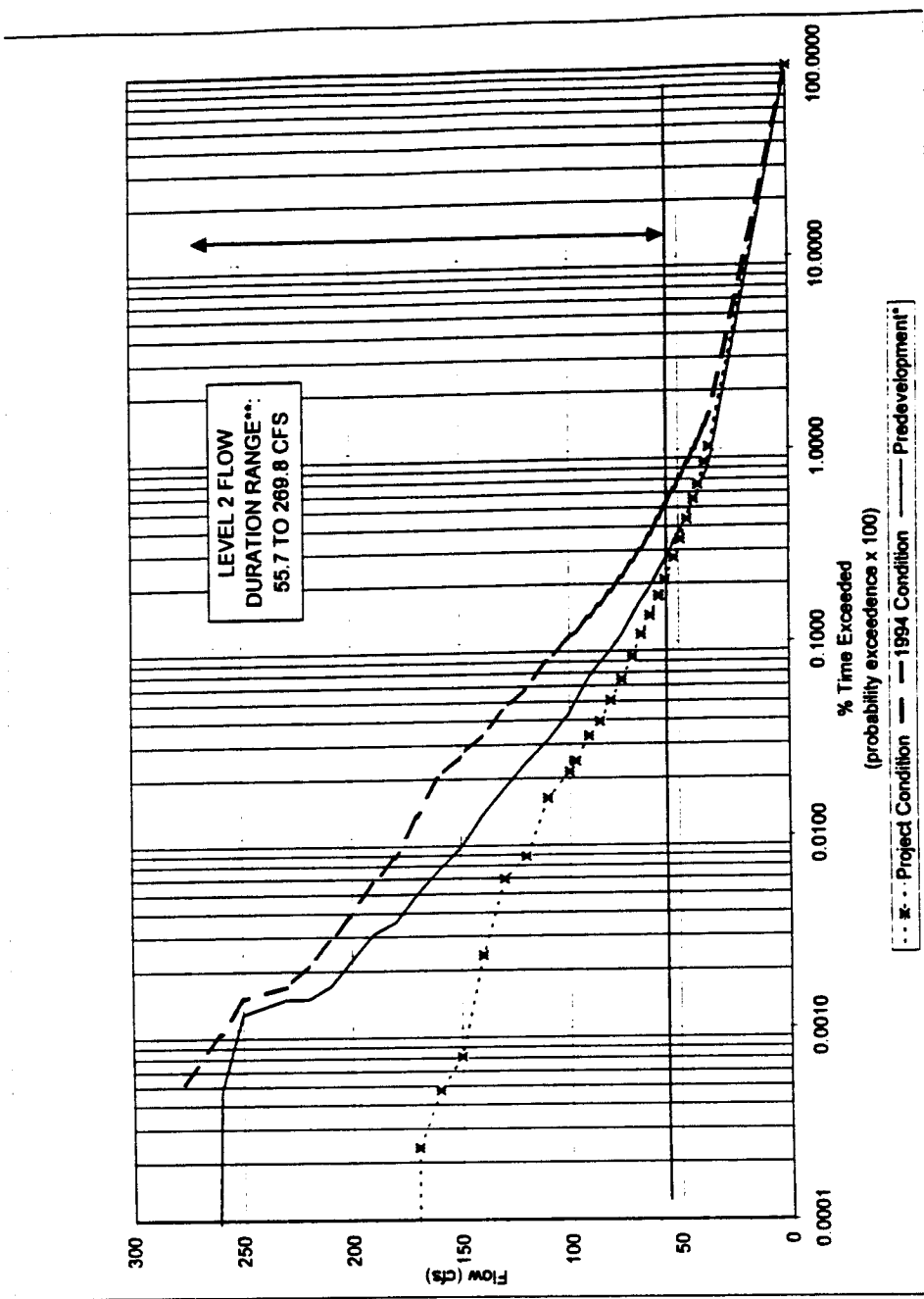
** For the target flow regime.

Figure 6.1-3
Flow Duration Curve for
Miller Creek at SR509



* Port basins use target flow regime (10-75-15). Off-site basins use 1994 conditions.
 ** For the target flow regime.

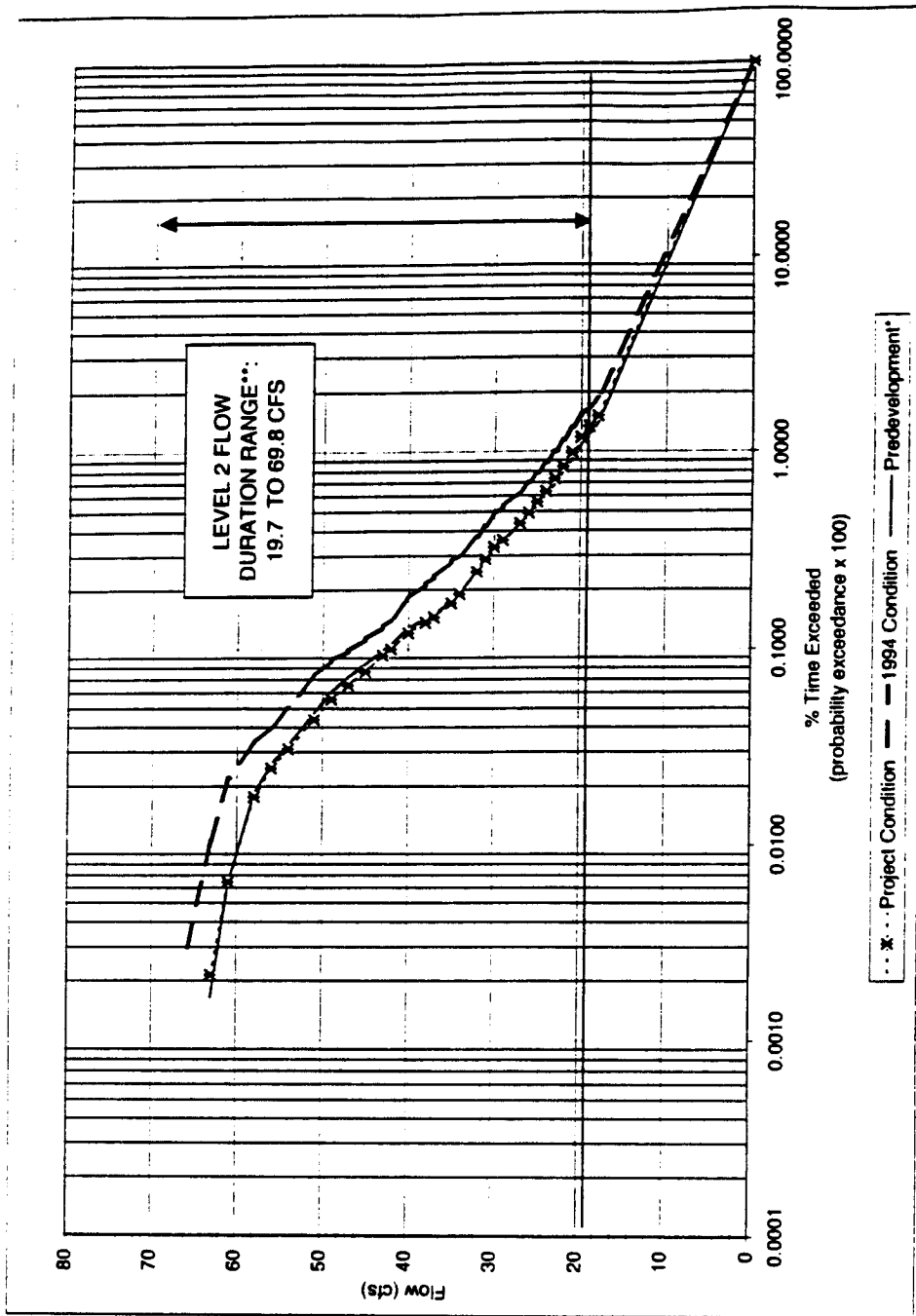
Figure 6.1-4
 Flow Duration Curve for
 Walker Creek at South 12th Street



* Port basins use target flow regime (10-75-15). Off-site basins use 1994 conditions.

** For the target flow regime.

Figure 6.1-5
Flow Duration Curves for Des Moines
Creek at South 200th Street



* Port basins use target flow regime (10.75-15). Off-site basins use 1994 conditions.
 ** For the target flow regime.

Figure 6.1-6
 Flow Duration Curve for
 Miller Creek at MCDF

6.1.2 Base Flow Impacts

Hydrologic modeling has also demonstrated a potential base flow impact due to the Master Plan Update improvements (Parametrix 2000a). The HSPF model was used to analyze the potential hydrologic effects on stream base flow¹⁸ after construction of the project in pervious areas. Results for the pre-project base condition (1994) were compared to the developed project condition (2006) in Miller, Walker, and Des Moines Creeks. Potential base flow changes were evaluated using a comparison between pre-project and project streamflow conditions during the typically driest times of year (August and September). Using HSPF, average changes in streamflow were simulated as shown in Table 6.1-5 (EarthTech 2000).

Table 6.1-5. Estimated Low Stream Flow Changes.

	Average Flows (cfs)					
	1994		2006		Change	
	Aug	Sept	Aug	Sept	Aug	Sept
Miller Creek	1.27	1.50	1.10	1.40	- 0.17	- 0.1
Walker Creek	0.033	0.035	0.031	0.039	- 0.002	+ 0.004
Des Moines Creek	1.08	1.64	1.07	1.73	- 0.01	+ 0.09

If base flow impacts are large enough, the wetted stream area could be reduced and adversely affect critical habitat. However, base flow impacts estimated for Miller, Walker, and Des Moines Creeks are insignificant and would not measurably change the wetted area of critical habitat.

While the HSPF modeling summarized in Table 6.1-5 indicates reduced low stream flow, some mitigative elements of project hydrology have not been calculated and are beyond the capability of the HSPF model to closely evaluate. For example, stormwater from detention ponds SDW1A and SDW1B in the Miller Creek basin will be infiltrated. Infiltration will offset some low flow reduction, as water will be infiltrated in trenches near Miller Creek to slowly seep through the soil back into the stream long after the rain has stopped. Also, stormwater that infiltrates into the fill embankment (a large soil mass that will collect, store, and transmit water) and slowly leaks out has not been accounted for in the HSPF model due to limitations in the model to simulate these constructed systems. The relatively small reductions in low flow shown on Table 6.1-5 will in fact be even less due to the limitations of the HSPF model to model these positive effects. Additional details on base flow impacts are provided in the *Seattle-Tacoma Airport Master Plan Update Improvements Low Streamflow Analysis* (Earth Tech 2000).

6.1.2.1 Effects of Peat Removal at Vacca Farm

Peat soils are often identified as having the ability to store water during wet periods and then release it slowly during dry periods, thereby augmenting base flows of associated streams. Excavation of peat soils during construction could alter hydrology and potentially affect base flow in Miller Creek.

¹⁸ Base flow is defined as the stream flow generated by groundwater in undeveloped watersheds. It is sometimes referred to as dry-weather flow.

The peat soil at the Vacca Farm site is identified as "Rifle" peat—fibrous, woody peat. It forms in depressions on top of glacial outwash soils such as the Vashon advance outwash, a medium dense sand soil series mapped in the vicinity of the Miller Creek valley. The Soil Conservation Service (SCS) estimates the permeability of similar peat soils to be on the order of 0.63 to 2 inches per hour (moderate permeability). An estimate of field capacity (the soil water content after gravity drainage from the peat has ceased), based on SCS data, is 0.4 (relatively high soil water retention). In comparison, the underlying dense sand in the outwash material has a permeability estimated at less than 1.4 inches per hour, and an available water capacity of about 0.1. The total porosity of the peat is assumed to be 0.8 (relatively high, thus a conservative assumption of greater maximum water storage).

The quantity of peat removed that could potentially provide water storage is about 10,000 cy. Therefore, the peat could store $(10,000 \text{ cy}) \times (27 \text{ cf/cy}) \times (0.8 - 0.4) = 108,000$ cubic ft of water. If the release rate to the stream were uniform during the drier months (May through September), the average daily flow would be on the order of $(108,000 \text{ cubic ft}) / (160 \text{ days} \times 24 \text{ hours} \times 60 \text{ minutes} \times 60 \text{ seconds}) = 0.008$ cfs. This estimate is high because it neglects evapotranspiration, which reduces the amount of water actually available to release as streamflow. Furthermore, the timing of the release of water stored in the peat is not likely to be uniform throughout the summer—most release would occur during late spring and early summer (May and June), prior to minimum streamflows. Thus, the potential impact on base flows from peat removal is likely considerably less than 0.008 cfs; this is unlikely to affect aquatic habitat in Miller Creek. In addition, the mitigation actions described in Chapter 5 include removal of drainage ditches, which will slow soil drainage at the Vacca Farm site.

6.2 WATER QUALITY

The Port's mitigation of potential water quality impacts is described in the SMP (Parametrix 2000a). Stormwater quality mitigation elements in the plan include the following:

- BMPs will meet or exceed stormwater quality treatment standards. BMPs will be applied to all new and redeveloped pollution-generating impervious surfaces (PGIS), and BMPs will be retrofitted to treat runoff from existing untreated PGIS where practicable. Upon completion of the Master Plan Update improvements and other anticipated projects (e.g., north terminal expansion), an estimated 490.3 acres (86 percent) of the STLA stormwater drainage system (SDS) will have water quality treatment BMPs, out of a total SDS PGIS area of 570.3 acres.
- Source control BMPs will be implemented for all PGIS, and regularly reviewed for additional or improved methods. Source controls are planned and implemented via the Port's Stormwater Pollution Prevention Plan (SWPPP) for Airport Operations (Port of Seattle 1998).
- A landscape management plan is included in the SWPPP. The landscape management portions of the SWPPP are intended to control water quality impacts from managed vegetated areas, including chemical use, container disposal, integrated pest management,

fertilizer application, weeding, pruning, and a prohibition of herbicide application near water courses.

- The IWS, a source control BMP, is designed to treat industrial wastewater from aircraft maintenance, fueling, and de-icing areas. The IWS is being upgraded so that storage overflows do not occur. The upgrade includes expansion of IWS Lagoon 3. The IWS upgrades are not a Master Plan Update project.
- Existing sources of stormwater pollutants will be removed from urban drainage areas. This includes removal of septic tanks, underground fuel storage tanks, untreated flows from lawns, streets, and driveways, and cultivated land located in stream floodplains and buffers.
- Projects will be implemented to enhance water quality such as flow augmentation, wetland restoration, stream restoration, and enhancement of riparian buffer zones within the Miller and Des Moines Creek basins.
- Hydrologic controls (peak flow and flow duration control, discussed in the flow control sections of the SMP) will reduce instream erosion.
- During construction, TESC's will be applied in excess of Ecology Manual (Ecology 1992) minimum requirements. TESC activities will include planning and implementing construction SWPPPs and monitoring plans for every individual Master Plan Update improvement activity, applying conventional TESC BMPs, providing advanced stormwater treatment where necessary and appropriate, supervising contractor erosion control compliance with an erosion control and stormwater specialist, and funding independent third-party oversight of construction erosion control and stormwater management and compliance.

As demonstrated in the SMP, concentrations of pollutants in STIA stormwater are generally less than those in runoff from other residential, urban, and industrial areas in the region. As the Master Plan Update improvements will consist of similar activities and BMPs, these actions are expected to mitigate or prevent impacts. The Port's ongoing compliance with the Clean Water Act and, in turn, protection of STIA's receiving waters, are demonstrated through compliance with its Section 402 (NPDES) Permit, administered in Washington by Ecology (Ecology 1998). As stated in the associated Fact Sheet for the Permit, "compliance with the effluent limitations and other conditions in this permit constitutes compliance with the Federal Water Pollution Control Act... and the Washington Water Pollution Control Act (RCW 90.48)."

7. OFF-SITE HABITAT MITIGATION: AUBURN WETLAND MITIGATION

The proposed Auburn Wetland Mitigation Site is a 67-acre parcel of land located within the City of Auburn immediately west of the Green River (see Figure 1.2-1). This mitigation project is designed to provide restoration and enhancement of forested, shrub, emergent, and open-water wetland habitats on over 65 acres of the 67-acre site to compensate for wetlands unavoidably impacted by the Master Plan Update improvements. The overall goal is to replace wetland habitat functions (especially for avian species) in an off-site location, in compliance with FAA Advisory Circular 150/5200-33 (FAA 1997b). The Port proposes to restore or enhance existing emergent wetland with diverse forest, shrub, emergent, and open-water wetland habitat, and restore buffer areas at the Auburn site as mitigation for habitat impacts. A summary of wetland impacts resulting from the Master Plan Update projects, proposed compensatory mitigation for each wetland type, and the overall replacement ratios provided by the Auburn mitigation site are provided in Table 7.1-1.

Table 7.1-1. Summary of wetland impacts and off-site compensatory design objectives for the proposed Master Plan Update improvements.

Project Impact	Compensatory Design Objectives	Acreage Provided ¹
Fill of 8.17 acres of forested wetland and loss of associated wildlife habitat.	Provide in-kind replacement of forested wetland functions and increase overall wildlife habitat function by creating/restoring emergent wetlands to create native forested habitat.	17.20 acres of forested wetland
	Enhance existing emergent wetlands to create native forested habitat.	19.50 acres of enhanced forested wetland
Fill of 2.98 acre of shrub wetland and loss of associated wildlife habitat.	Provide in-kind replacement of shrub wetland functions and increase overall wildlife habitat function by enhancing and restoring emergent wetlands.	6.00 acres of shrub wetland
Fill of 7.22 acres of emergent wetland and loss of associated wildlife habitat.	Provide functional replacement of emergent wetlands and increase wildlife habitat function by restoring emergent wetland.	6.20 acres of emergent wetland
	Provide pockets of open-water habitat.	0.60 acre of open-water wetland
Protect the wetland from potential off-site disturbance and provide enhanced upland wildlife habitat.		
Approximately 15.90 acres of forested buffer protect the site from potential off-site disturbance and provide upland habitat.		

Wetland mitigation immediately adjacent to the existing airport is constrained by the need to avoid creating wildlife hazards (i.e., waterfowl and flocking bird habitat) near the airfield (FAA 1997b). Therefore, the focus of the in-basin mitigation projects (Chapter 5) is to replace and enhance wetland functions, including hydrologic, water quality, aquatic habitat and riparian support functions, to the extent practicable, while reducing existing wildlife hazards and avoiding the creation of new wildlife hazards. As a consequence, in-basin projects will not create or enhance open-water or emergent wetland habitats that could attract waterfowl. Due to this constraint on-site

mitigation, the Port therefore proposes to include significant additional restoration, creation, and enhancement of palustrine forest, shrub, emergent, and open-water habitats at the Auburn mitigation site to compensate for impacts to these habitats by the project.

Much of the emergent wetland habitat that will be impacted by the Master Plan Update projects is relatively low quality habitat that has been significantly altered and degraded by development. The Miller and Des Moines Creek basins historically supported forested or shrub wetlands dominated by a diverse native flora. The vegetation in existing emergent wetlands filled or disturbed by the project is generally maintained by on-going anthropogenic disturbance (i.e., mowing, golf course maintenance). In the absence of this disturbance, these wetlands would develop into forested or shrub wetlands. The emergent wetlands are also relatively low quality habitat for most wildlife species because of on-going disturbance, and a lack of vegetation diversity. Similarly, many of the existing shrub wetlands are dominated by non-native invasive species such as Himalayan blackberry, and in the absence of disturbance would develop into forested wetlands. Existing shrub wetlands also provide low quality habitat due to frequent disturbance and lack of habitat diversity.

For these reasons, the off-site mitigation has been designed to provide improved avian habitat conditions relative to the existing wetlands lost near STIA. Off-site mitigation emphasizes the development of forested wetlands, because over time, and in the absence of on-going human disturbance, most of the wetlands impacted by the Master Plan Update projects would develop into forested wetlands similar to those historically found in the area. Therefore, the wetland mitigation provided at Auburn (see Table 7.1.1) is not strictly in-kind mitigation of habitat types, and creates a greater amount of generally higher quality forested wetlands compared to the lower quality emergent and shrub wetlands found near STIA.

This chapter describes the off-site mitigation and monitoring plan. Overall goals and design criteria are described in Section 7.1. The mitigation site and site selection process are described in Section 7.2 and Section 7.3 contains a detailed description of the mitigation design, including a description of construction methods and implementation of the mitigation plan. Finally, Section 7.4 describes the implementation of the project at the mitigation site. Detailed plan sheets showing design elements are included in Appendix E.

7.1 GOALS, OBJECTIVES, AND DESIGN CRITERIA

Goals, objectives, and design criteria for the Auburn off-site wetland mitigation have been developed to guide the mitigation design and ensure that overall mitigation objectives are met (Table 7.1-2). The wetland mitigation goals and objectives identified below are designed to compensate for unavoidable wetland impacts, especially to wildlife habitat, by creating forested, shrub, emergent, and open-water replacement wetland habitat with a net gain in functional value and acreage.

Table 7.1-2. Mitigation goals with associated design objectives and design criteria for the Auburn Mitigation Site.

Goals and Design Objectives	Design Criteria
Goal 1: Achieve no net loss of wetland acreage by constructing replacement habitats of forest, shrub, and emergent wetland with a forested buffer	
Provide seasonal to permanent wetland hydrology appropriate for each wetland vegetation cover type.	<p>Use a perched water table to establish wetlands at the approximate final grades of:</p> <ul style="list-style-type: none"> 41 ft to 38 ft in emergent wetlands 42 ft to 41 ft in shrub wetlands 45 ft to 42 ft in forested wetlands Below 38 ft in open-water wetland 42 ft to 44 ft in emergent wetlands 44 ft to 46 ft in shrub wetlands 46 ft to 49 ft in forested wetlands Below 42 ft in open-water wetland
Provide in-kind replacement for impacts to 8.17 acres of native forested wetland.	<p>Plant five forested wetland plant associations that are similar in composition to naturally occurring plant associations. Use native deciduous and evergreen species such as black cottonwood, Oregon ash, red alder, western redcedar, and Sitka spruce.</p> <p>Forested communities will have a native shrub understory with species such as salmonberry, twinberry, red-osier dogwood, red elderberry, willows, and vine maple.</p> <p>Plant native tree species at densities greater than 280 trees per acre.</p> <p>Plant native shrub species in forested communities at densities greater than 1,800 plants per acre.</p>
Provide in-kind replacement for impacts to 2.98 acres of native shrub wetland.	<p>Plant an association of native shrub wetland species that is similar in composition to naturally occurring shrub wetlands, including species such as Pacific willow, Hooker's willow, Sitka willow, red-osier dogwood, and twinberry.</p> <p>Plant native shrub species at densities greater than 2,100 plants per acre.</p>
Provide replacement for impacts to 7.22 acres of native emergent wetland.	<p>Plant an association of native emergent wetland species similar in composition to native emergent wetlands. Use native species that are suited to seasonally and/or permanently flooded conditions, such as water parsley, hardstem bulrush, and common spike rush.</p> <p>Plant native emergent species in approximately 0.05-acre monotypic patches at densities greater than 10,000 plants per acre (approximately 24 inches on-center).</p>
Provide a forested buffer around the mitigation site to enhance functions and protect of the wetland mitigation	<p>Establish a 100-ft-wide forested buffer around the perimeter of the mitigation site</p>
Goal 2: Provide wildlife habitat replacement outside the 10,000-ft safety radius for aircraft operations.	
Provide flooded emergent wetland habitat suitable for waterfowl feeding and resting during the winter and spring months.	<p>Emergent wetlands will satisfy the design criteria for Wetland Mitigation Goal 1. Additional design criteria for waterfowl habitat include:</p>

Table 7.1-2. Mitigation goals with associated design objectives, design criteria, and final performance standards for the Auburn Mitigation Site (continued).

Goals and Design Objectives	Design Criteria
Provide emergent, shrub, and forested wetland habitat with feeding and breeding for songbirds.	<p>Provide year-round shallow water with patches of emergent vegetation as feeding habitat for dabbling duck species.</p> <p>Provide ponded water areas for resting habitat.</p> <p>Forested, shrub, and emergent wetlands will satisfy the design criteria for Wetland Mitigation Goal 1. Additional design criteria for songbird habitat include:</p> <p>Plant forested wetland adjacent to shrub, emergent, and open-water habitats</p> <p>Plant portions of the forested wetland with shrub understory species to provide a multiple-layered canopy adjacent to the shrub portion of the wetland.</p>
Provide forested, shrub, and emergent wetland feeding and breeding habitat for small mammals.	<p>Forested, shrub, and emergent wetlands will satisfy the design criteria identified for Wetland Mitigation Goal 1. Additional design criteria for small mammal habitat include:</p> <p>LWD (stumps and logs of native species) placed throughout the forested wetland to provide year-round cover for small mammals.</p> <p>Low hummocks constructed in the shrub wetland areas to provide non-saturated soils for burrowing small mammals.</p>
Provide breeding habitat for amphibians.	<p>Forested, shrub, and emergent wetlands will satisfy the design criteria for Wetland Mitigation Goal 1. Additional design criteria for amphibian habitat include:</p> <p>Provide attachment substrate for breeding amphibian species in areas of ponded water.</p>
Goal 3: Provide replacement wildlife habitat that increases overall habitat functions	
Consolidate mitigation for impacts to many small, discontinuous wetlands into a single, larger wetland to provide a more diverse aggregate of habitat types.	Construct a contiguous wetland system with forested, shrub, and emergent wetland types and wildlife habitat features that provide in-kind and out-of-kind habitat replacement.
Assure long-term protection of the mitigation site(s).	<p>Screen the wetland from off-site areas and install fencing around the perimeter.</p> <p>No public trails will be permitted on the mitigation site.</p>
Goal 4: Enhance the existing 19.5-acre emergent wetland at the Auburn site.	
Enhance functions of approximately 19.5 acres of degraded emergent wetland.	Plant existing wetland with native trees and shrubs at densities greater than 2,100 individual plants per acre for shrubs and greater than 280 stems per acre for native trees.

7.1.1 Goals and Objectives

The general mitigation goals for the Auburn site are as follows:

- Achieve an overall increase in wetland acreage and functional replacement at a mitigation ratio of at least 2:1.
- Mitigate lost habitat functions of the Master Plan Update improvements outside of the 10,000-ft aircraft operations safety radius of STIA to protect public safety and reduce wildlife hazards to aircraft.
- Create diverse wetland habitats (including forested, shrub, open water, and emergent) as well as upland forested habitat on a large site adjacent to existing habitat corridors along the Green River.
- Enhance wetland functions in the existing degraded wetlands, which are dominated by non-native species, by converting them to diverse, native forested, shrub, and emergent wetlands.
- Provide long-term protection for the mitigation site by providing a 100-ft forested buffer around the perimeter of the site.

7.2 WETLAND MITIGATION SITE

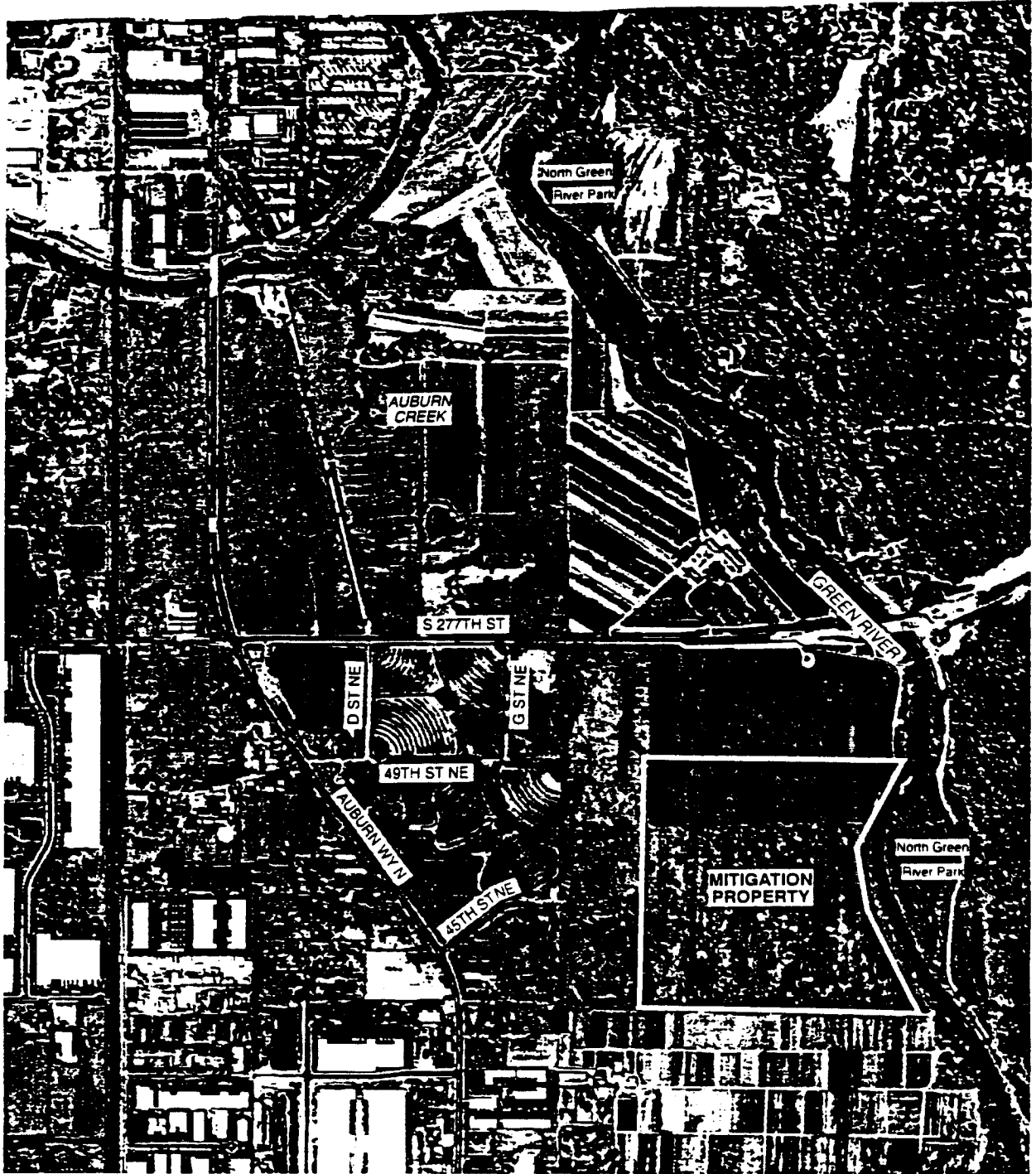
The mitigation site chosen for off-site compensatory mitigation for the Master Plan Update improvements is described in the following sections.

7.2.1 Site Description

The mitigation area is part of a 67-acre parcel located within the City of Auburn immediately west of the Green River (Figure 7.2-1). The site is nearly level but gradually slopes from the eastern (approximately 52 ft in elevation) and southeastern boundaries to approximately 45 ft in elevation in the northwest corner. The undeveloped parcel has been farmed in the recent past, and currently supports a mix of upland and wetland pasture grasses and forbs that are common on abandoned agricultural land in the Puget Sound basin. The mitigation site is located between 100 and 150 ft west of the OHWM of the adjacent Green River.¹⁹

The site is bounded by a variety of land uses including active agriculture fields to the north and south; undeveloped land, multi-family housing, and a drive-in theater to the west; and the Green River, patches of riparian forest, and undeveloped, forested slopes to the east. The site was previously zoned single-family residential (R2) by the City of Auburn, and the 1995 Comprehensive Plan designation is single-family (Auburn 1995). In 1998, a new section was added to the City's zoning ordinance that allows wetland mitigation to occur in R2 zoning. The mitigation site is located within the Draft Mill Creek Special Areas Management Plan (SAMP) (ACOE 1997). The relationship of this project to the Draft SAMP is discussed in Section 7.2.3.

¹⁹ Approximately 1.62-acres along the eastern boundary of the 67-acre is set aside for potential development as part of a regional trail that may be built by King County.



Port of Seattle Natural Resource Mitigation Plan 556-2912-001/01/03: 12:00 (K)

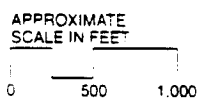


Figure 7.2-1
Aerial Photograph of the Auburn
Wetland Mitigation Site (1999)

AR 048850

Three jurisdictional wetlands were delineated on the mitigation site. Wetland 1 extends from the northwest corner to the south-central portion of the site (Figure 7.2-2) and covers 18.89 acres of the site. The wetland also extends east, off-site to the east, through the access easement for the site. Wetland 2 is adjacent to Wetland 1 in the south-central portion of the site, and is about 0.60 acres in size. Wetland 3 is located in the north-central portion of the site and is about 0.01 acre in size (Parametrix 2000c). Descriptions of site hydrology, soils, and vegetation of the wetland and upland portions of the site are included in the following sections.

7.2.2 Ownership

The Port owns the entire 67-acre site and has a permanent access easement on the western side of the property (Appendix E, Sheet C2). Construction of the mitigation project requires temporary construction access easements, and a temporary drainage and construction easement that will allow the Port to modify an existing drainage ditch for drainage related to construction of the wetlands. A permanent easement allows monitoring and maintenance following construction. The Port has obtained these easements.

7.2.2.1 Construction Access

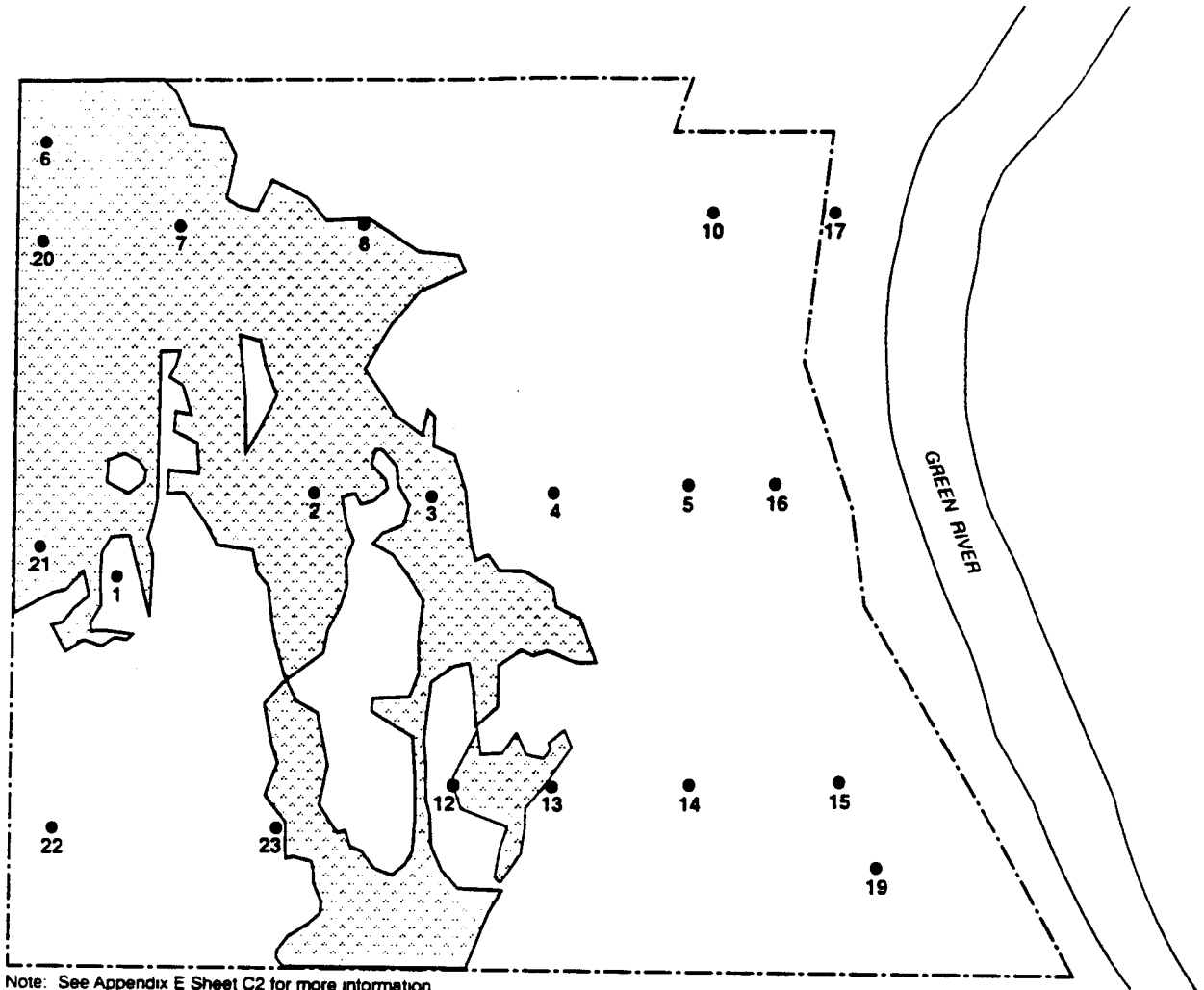
The Port has procured temporary construction and access easements from property owners to the west of the site for construction access to the mitigation project. As of December 2000, the Port had completed easement agreements from two property owners and was in the process of completing negotiations with three other owners.

7.2.2.2 Drainage Easement

The Port has also procured a temporary drainage and construction easement across the property north of the mitigation site (Appendix E, Sheet C2). The purpose of this easement is to grant the Port the right to modify an existing channel for drainage purposes related to construction of the mitigation project. The easement grants the Port the right to use this channel for the temporary discharge of water from dewatering wells to be used during excavation and construction of the mitigation wetlands. During dewatering, drainage water from the Port's property will be temporarily channeled to the existing outfall into the Green River at South 277th Street. Other than during construction dewatering, drainage water from the mitigation site will flow north through existing drainage channels along and under 277th Street, and then north to the Green River. The temporary drainage and construction easement will remain in effect until a permanent flood channel is constructed across the property to the north.

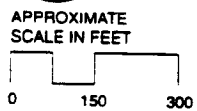
7.2.2.3 Permanent Flood Channel




Construction of a permanent flood channel is a condition of the Interlocal Agreement (ILA) between the Port and the City of Auburn. The ILA requires the Port to construct, or with the consent of the City, to pay the cost of constructing the floodway channel. The ILA requires that the flood channel be located in a mutually agreed upon location across the property to the north of the mitigation site (i.e., the Bristol property). The Port is currently working with the City of Auburn and Bristol on the design and location of the floodway channel. Although a final determination has



Note: See Appendix E Sheet C2 for more information.

Port of Seattle/Natural Resource Mitigation Plan/556-2912-001/01(03) 12/00 (K)



-  Existing Wetland
-  Well Location
-  Site Boundary (Approximate)

**Figure 7.2-2
Wetlands and Groundwater
Monitoring Well Locations
on the Wetland Mitigation Site,
Auburn, Washington**

AR 048852

not been made as of December 2000, the existing channel is the most probable location of the permanent floodway channel (Appendix E, Sheet C2). Widening and deepening the existing drainage channel to construct the permanent floodway will result in impacts to a maximum of 2.2 acres of Waters of the U.S., and these impacts have been included in the project's CWA 404 permit application.

7.2.3 Rationale for Selection

Mitigation site selection began with a review of the established goals as outlined in Section 7.1.1. The general site criteria required to meet these goals are similar to those listed by Castelle et al. (1992) and are listed below:

- A large non-wetland site, greater than 50 acres in size, with evidence of a seasonally high water table
- A non-forested site (to allow for significant net habitat improvements) adjacent to a higher quality habitat area (i.e. the Green River Riparian Corridor)
- A site with relatively flat topography
- A vacant or substantially vacant site
- A site available for purchase by the Port
- A site at least 10,000 ft from proposed or existing runways as recommended by the FAA (FAA 1997b)

As described in Chapter 4, the recommended preference for selecting wetland mitigation sites in the State of Washington is as follows: (1) on-site and in-kind; (2) off-site, within the watershed, and in-kind; (3) off-site, out of the watershed, and in-kind; and (4) off-site, out of the watershed, and out-of-kind (Ecology 1990). The Port's mitigation for wetland impacts follows these recommendations and the majority of mitigation for most wetland functions is located on-site, but outside of the STIA operations area to avoid hazards to aircraft. However, creating new wetland habitat within the STIA operations area was eliminated from consideration because the site criteria listed above could not be met. Additional on-site mitigation near STIA was not considered because it could be subject to degradation from wildlife control for safety reasons. Therefore, consideration of off-site mitigation was necessary.

7.2.3.1 Wetland Mitigation and Aircraft Safety

Bird-aircraft collisions (bird strikes) are a significant concern to the Port, the FAA, and the aviation community in general. Bird strikes threaten passenger safety, result in costly aircraft repair, cause passenger delays, and decrease revenue for commercial air carriers (Soloman 1973; Seubert 1977). In the United States, annual costs due to bird strikes have been estimated to be \$112 million to military aircraft (Conover et al. 1996). Conover et al. (1996) estimate that for civilian aviation, about 33 percent of bird strikes are unreported, and that the annual rate for civilian aircraft is 6,240 strikes (the cost of these strikes was not estimated). Annual loss of life associated with bird strikes is less than three fatalities for all branches of the military, and 3.7 fatalities for civilian/commercial

aviation (Conover et al. 1996). For these reasons, bird control in and around airports has become an important component of airport management.

The reported bird strikes at the STIA are summarized in Table 7.2-1. STIA is required by the FAA (as part of the Part 139 Airport Certification Program) to maintain and implement a wildlife hazard management plan (Port of Seattle 1992) to minimize bird strike hazards. Because of certification requirements and the Port's desire to maintain safe aircraft operations, it is compelled (where feasible) to eliminate bird hazards as part of the management plan. These hazards can be eliminated or reduced by hazing (scaring) birds from problem areas, killing wildlife (per permits issued by the U.S. Fish and Wildlife Service), or modifying habitat so it is no longer suitable for wildlife creating the hazards (Port of Seattle 1992).

Table 7.2-1. Summary of reported bird strikes at Seattle-Tacoma International Airport (1979-1999).

Year	Number of Strikes
1979	5
1980	8
1981	15
1982	4
1983	8
1984	3
1985	11
1986	12
1987	11
1989	7
1990	35
1991	13
1992	13
1993	14
1994	22
1995	21
1996	22
1997	27 ¹
1998	13 ¹
1999	21
Average	13.5

¹ These numbers include carcasses found near the airfield.

FAA policy regarding wildlife attractants near airports includes the position that any activity or land use on or near an airport that threatens aircraft safety by attracting or sustaining hazardous wildlife is not a compatible land use (FAA 1997b). The FAA recommends all new wildlife attractants be 10,000 ft from turbine aircraft movement areas, and 5 miles from an airport where wildlife could be attracted to or across the airport's approach or departure airspace. The FAA and the Port believe that wetland mitigation created as habitat for wildlife is a land use that should not occur near STIA.

There are compelling reasons to support decisions to mitigate for wildlife habitat mitigation greater than 10,000 ft from active runways. *Port of Seattle Position Paper re: Off-Airport Mitigation of Wetland Wildlife Habitat Function* (Port of Seattle 1998b) provides detailed explanation of off-airport mitigation needs. The reasons for off-airport mitigation discussed in that paper are summarized as follows:

- Creation of wetland wildlife habitat near the airport would increase the hazards to passenger safety. In the United States, more than 1,700 bird strikes occur each year. Worldwide since 1995, 74 people have been killed as a result of bird strikes and four large aircraft have been destroyed. For these reasons, FAA Advisory Circular 150/5200-33 recommends locating replacement wetlands more than 10,000 ft from runways serving turbine-engine airplanes. The FAA and the Department of Agriculture Animal Damage Control Division believe strongly that wetland wildlife habitat should not be created near STIA.
- If the Port were to create wetland wildlife habitat near the airport, it would be required to manage the wetland to prevent its attraction to birds. These management activities could be directly contrary to the key purpose of creating the habitat.
- The FAA has required, as a condition of its approval of the STIA improvements and as a condition of federal funding, that the Port comply with the FAA Advisory Circular and locate the replacement wetlands in Auburn. If the Port did not follow this requirement, it would likely lose essential federal funding for the airport projects.
- Constructing a replacement wetland in proximity to the airport raises liability concerns for the Port. Federal courts have found airport operators liable for failing to mitigate and warn pilots of wildlife hazards.

Considering the Port's and the FAA's mandate to provide a safe environment for aircraft operations, the construction of wetland mitigation to provide wildlife habitat is not feasible near (within 10,000 ft) an existing or proposed runway. A wetland mitigation project designed to provide forest and shrub wetland habitat (to discourage waterfowl use and replace functions in-kind) could attract additional numbers of birds known to be a strike hazard at the airport. These include flocking birds (starlings, blackbirds, and pigeons), raptors (owls and hawks), and other common passerine (perching) birds. These increased numbers could require management actions by the Port and FAA (such as modification of the mitigation site to discourage wildlife use) that would be contrary to federal and state wetland regulations and policies.

The Port is attempting to decrease the aircraft/bird strike hazard at STIA as described in the WHMP (USDA 2000). The addition of new wildlife habitat near airport runways could undermine the ongoing effort to maintain and enhance airport safety and would not meet the goals of the Master Plan Update in which landing and takeoff safety is a major consideration.

7.2.3.2 In-basin Sites

A Geographic Information System (GIS) database (Puget Sound Regional Council 1994) was used to locate potential mitigation sites within the Miller Creek and Des Moines Creek watersheds. The GIS program identified all undeveloped, non-forested, non-wetland sites with average slopes less than 5 percent. It was assumed that, if available for purchase, these were the minimum criteria necessary for a suitable mitigation site. Based on these criteria, 19 potential mitigation sites were

*Natural Resource Mitigation Plan
Seattle-Tacoma International Airport
Master Plan Update*

7-11

*December 2000
556-2912-001 (03)*

G:\DATA\working\291203291\20103\map\2000 NRM\PC\Current\version1\Master2.doc

AR 048855

identified (Figure 7.2-3). The suitability of the sites (although all are within the 10,000-ft radius of concern for wildlife hazards to aircraft [FAA 1997b]) for wetland mitigation was evaluated during site visits on August 28, 1996 (Table 7.2-2).

The site selection criteria were altered because undeveloped sites greater than 50 acres were lacking in the two watersheds. For this level of analysis, it was assumed that drainage conditions on each site identified by the GIS program could be modified to retain adequate water to support wetlands, so evidence of high water tables was not considered. For this project, a mitigation site in excess of 50 acres is preferred because it would allow a mitigation ratio of at least 2:1 and allow protection of the site with adequate wetland buffers. In addition, sites greater than 50 acres would combine the functions of several small, isolated wetlands in a single large wetland mitigation project, enhancing the probability of achieving mitigation goals, ensuring long-term protection, and ultimately providing wetland functions to compensate for project impacts (Federal Register 1995; U.S. EPA and ACOE 1993). However, all sites greater than 10 acres were evaluated because there were few large undeveloped sites on suitable terrain in either watershed.

7.2.3.3 Out-of-basin Sites

The search for off-site mitigation areas began by reviewing over 100 parcels for their suitability as wetland mitigation. The review focused on sites larger than 50 acres because of the acreage needed to mitigate impacts and the ecological and logistical advantages of developing mitigation on a single site. Other constraints identified for off-site areas included:

- Site selected should be in proximity to impact site and not conflict with other planned wetland mitigation projects in the Duwamish watershed
- Land not constrained by development restrictions (such as King County's Farmland Preservation Program)
- Land that is economically feasible for purchase and construction of desired mitigation
- Sites greater than 10,000 ft from proposed or existing STIA runways
- Sites greater than 5,000 ft from general aviation runways (for airports located within the Cities of Auburn and Kent)

In addition to the above constraints, a preference was given to suitably sized, non-wetland areas that were close to surface water or other riparian habitat areas. The mitigation site would then provide ecological functions to off-site areas.

Of eleven sites larger than 50 acres, five sites were rejected as unsuitable due to the large amount of wetlands present or because they offered minimal opportunity for habitat improvement. Of the six remaining sites, two were not available for purchase, the development rights of two were owned by King County for farmland preservation, and one site had been recently purchased by the City of Kent for its own mitigation purposes.

Off-Site Mitigation

AR 048857



File: 048858.dwg, 11/17/2006, 11:17 AM, 11/17/2006, 11:17 AM, 11/17/2006, 11:17 AM, 11/17/2006, 11:17 AM

- Road
- Major Highway
- Watershed boundary
- Present Runways
- Proposed 3rd Runway, Runway Safety Areas, and Runway Extensions
- Borrow, Warehouse/ Parking or SASA area
- Slope less than or equal to 5%
- Non-developed/non-forested
- Slope <= 5% and non-developed/non-forested
- 8 — Potential wetland mitigation
- 10,000-Foot Radius From Proposed Runways
- City Boundary



Figure 7.2-3
Potential Mitigation Sites
Evaluated in the Miller Creek
and Des Moines Creek Watersheds

0 2000 4000 6000

Scale in Feet

Table 7.2-2. Summary of potential mitigation sites analyzed within the Miller Creek and Des Moines Creek watersheds (see Figure 7.2-3).

Site	Watershed	Acres	Existing Conditions	Mitigation Limitations
1	Miller Creek	55	The site is within the direct flight path to the airport. It is within a vacated residential area and has been identified for development as the North Sea Tac Park (which includes play fields, a picnic shelter, restrooms, a playground, parking, and trails), pursuant to an agreement between the Port and the City of Sea Tac.	Use of the site for wetland mitigation would eliminate use of much of the site as a community park. The site is approximately 6,400 ft north of the existing runways. Enhancement of wildlife habitat in this area would increase wildlife hazards to aircraft.
2	Miller Creek	14	The area is within the direct flight path to the airport. It is in an abandoned residential area with scattered deciduous trees, blackberries, grasses, and weeds. The site drains from east to west into Tub Lake.	Some slopes on the site are steeper than mapped in the GIS database, and only approximately 5 acres of the site are suitable for wetland creation. Therefore, this site is not large enough. The site is 4,500 ft north of the existing runways, and enhancement of wildlife habitat in this area would increase hazards to aircraft.
3	Miller Creek	33	The area is in a vacated residential area in the direct flight path to the airport. Vegetation is largely comprised of blackberries, ornamental trees, grasses, and weeds. The smaller, northern portion of the site connects to the Tub Lake wetland on one side, with an approximate rise in elevation of 30 to 50 ft on other sides. The southern portion of the site is also topographically higher than the Tub Lake wetland.	The site is fragmented by three streets, which could be detrimental to wildlife. The site is approximately 2,600 ft north of the nearest existing runway. Creation of wetland habitat at this site would increase wildlife hazards to aircraft.
4	Miller Creek	17	The area is at a topographic high point in the direct flight path of the airport. There are patches of mixed deciduous and ornamental trees. A large water tower is in the northern portion of the site.	The area is not large enough to mitigate wetland impacts at one site, and there is no wildlife corridor to the other potential sites or other habitat areas. The site is within the fenced airport security area, which would preclude use of the wetland by some forms of wildlife, including deer, coyote, and fox. The site is within the area of proposed Master Plan Update improvements where warehouse and parking is proposed. This site is approximately 2,300 ft north of the nearest runway. Wetland creation would not be feasible due to the proximity of low-flying aircraft and increased wildlife hazards

Table 7.2-2. Summary of potential mitigation sites analyzed within the Miller Creek and Des Moines Creek watersheds (see Figure 7.2-3) (continued).

Site	Watershed	Acres	Existing Conditions	Mitigation Limitations
5	Miller Creek	11	The site is on a slope within the fenced airport security area. Patches of deciduous and ornamental trees are scattered throughout the site.	Most of the site would be developed as part of the Master Plan Update improvements. Only about 1 or 2 acres would remain after construction. The proximity to existing airport operations (approximately 2,000 ft from existing runways and 1,000 ft from the proposed runway) would result in increased wildlife hazards to aircraft. Locating wetland habitat within the airport operation area is not feasible for safety reasons.
6 and 7	Miller Creek	45	These sites are grassy areas between the existing runways and taxiways within the airport operation area.	
8	Miller Creek	23	This site consists of landscaped yards in a semi-rural residential area west of the airport. Miller Creek flows through portions of the relatively flat site.	The eastern portion of this site is within the fill footprint for the proposed runway. The remaining portion of the site is not large enough to mitigate for the wetland impacts. The mitigation area would be isolated from other habitat areas by South 154th Street, the airport, and SR 509, which would not be conducive to optimal wildlife habitat. The mitigation area would be 3,100 ft southwest of the end of the nearest existing runway and 2,100 ft southwest of the end of the proposed runway. The site is approximately 1,000 ft directly west of the edge of the proposed runway. The proximity of airport operations increases the wildlife hazard to low-flying aircraft. It is not reasonable to locate wetland mitigation in a cemetery. The proximity of the site (3,600 ft southeast of the end of the nearest runway and 2,600 ft east of the edge of the nearest runway) to runways presents a wildlife hazard to aircraft. Locating wetland habitat within the airport operations area is not feasible due to safety reasons.
9	Des Moines Creek	24	The site is a cemetery.	
10, 11, 13, and 14	Miller Creek (sites 10 and 13) and Des Moines Creek (sites 11 and 14)	100	These sites are located between and adjacent to the existing runways and taxiways. They are grassy areas mowed and maintained for airport safety reasons.	

Table 7.2-2. Summary of potential mitigation sites analyzed within the Miller Creek and Des Moines Creek watersheds (see Figure 7.2-3) (continued).

Site	Watershed	Acres	Existing Conditions	Mitigation Limitations
12	Miller Creek	16	This relatively flat area consists of large expanses of lawn bordered by roads, houses, and a large scrub/shrub wetland.	<p>Wetland mitigation at this site would require displacement of additional residents.</p> <p>The site is not large enough to mitigate all of the wetland impacts at one location.</p> <p>The area is bordered by major roadways (SR 509 and Des Moines Way S) on two of the three sides, which would not be conducive to optimal wildlife habitat.</p> <p>Mitigation would be about 1,800 ft west of the proposed runway and approximately 4,500 ft from either end of the proposed runway. The proximity of the proposed runway to mitigation would increase the hazard to aircraft.</p> <p>Less than half of the site would be available for wetland mitigation due to the surrounding topography and the presence of existing wetland. The proximity of a trailer park, hotel, and single-family homes, and the small size of available upland area make this site undesirable for wetland habitat mitigation.</p> <p>The site is roughly 5,200 ft east of the ends of the existing runways, and 4,700 ft east of the edge of the nearest runway.</p> <p>Much of the area is included in the Master Plan Update improvement area (including the safety area currently under construction and the SASA). If the preferred alternative for the airport expansion is implemented, there would not be enough suitable land remaining for wetland creation.</p> <p>Mitigation at this site may not be protected in perpetuity due to the proximity of airport operations. It is approximately 1,500 ft south of Runway 34R, which would increase wildlife hazards to aircraft.</p>
15	Des Moines Creek	11	Site 15 is a horse pasture surrounded on three sides by steep slopes. A scrub/shrub wetland, which connects to Bow Lake, lies on the western side of the pasture. Single-family homes, a trailer park, and a hotel overlook the site.	
16	Des Moines Creek	35	Site 16 is located in the direct flight path and consists of the northern portion of Tyee Valley Golf Course. Currently, a safety area for Runway 34R, which encroaches on the golf course, is under construction.	

Table 7.2-2. Summary of potential mitigation sites analyzed within the Miller Creek and Des Moines Creek watersheds (see Figure 7.2-3) (continued).

Site	Watershed	Acres	Existing Conditions	Mitigation Limitations
17	Des Moines Creek	23	This site is the southern portion of Tyee Valley Golf Course. It is bordered by a mixed forest to the west and south, residential and recreational uses to the east, and the northern portion of the golf course to the north. Des Moines Creek divides the northern and southern portions of the golf course.	The site would be confined by ongoing disturbances or developments including the airport, the SASA area, and borrow areas for construction of the proposed runway, which is not conducive for wildlife habitat replacement. It is 2,100 ft directly south of the end of Runway 34R, which would result in increased wildlife hazards to aircraft. There is not enough land to mitigate wetland impacts on one site that could be protected in perpetuity. The necessary acreage required for compensatory mitigation could not be attained at this site. It is fragmented by homes and active roads, and residents would have to be displaced for mitigation.
18	Des Moines Creek	16	This site consists of grass pastures and landscaped yards adjacent to a forested area on the west side, and residential areas to the north, east, and south. Most of the site is on a topographically high area.	The site is approximately 4,900 ft south of the existing runways and would increase wildlife hazards to aircraft. The necessary acreage required for compensatory mitigation could not be attained at this site. It is fragmented by homes and active roads, and residents would have to be displaced for mitigation.
19	Des Moines Creek	12	Site 19 consists of landscaped yards and some pasture area with a large forested area to the north. Most of the site is topographically high.	Site 19 is approximately 5,200 ft south of the existing runways, and would increase wildlife hazards to aircraft.

Note: Data compiled by Parametrix.

The remaining site, analyzed in this plan, has several attributes that make it favorable for wetland mitigation. It is large enough to accommodate the entire wetland mitigation project and has physical features that could successfully support the proposed mitigation approach. These features include proximity to the Green River and a seasonally high water table.

The mitigation site is within the boundary of the Mill Creek SAMP (ACOE 1997). This mitigation project enhances existing wetlands and creates wetlands from upland areas, enhances the aquatic resources of the basin, and is consistent with the goals and objectives of the SAMP. The Draft SAMP identifies specific wetland areas on which development would be permitted by a Regional General Permit, and other areas where protection and enhancement of wetlands will be required. The overall goal of the Draft SAMP is to provide for aquatic resource protection and economic development in the Mill Creek basin while assuring no net loss of aquatic resource functions and values of the basin.

7.2.4 Constraints

No construction or implementation constraints have been identified that would affect the success of the wetland mitigation at the Auburn site.

7.2.5 Ecological Assessment of the Mitigation Site

The ecological conditions of the upland and wetland areas of the proposed mitigation site are discussed in this section. The existing wetlands are described in more detail in Appendix A of the *Wetland Delineation Report* (Parametrix 2000c).

7.2.5.1 Existing Site Conditions

Vegetation

The mitigation site consists primarily of abandoned agricultural land. Vegetation is a mix of native and non-native herbaceous species, including meadow foxtail (*Alopecurus pratensis*), Canada thistle (*cirsium arvense*), quackgrass (*Agropyron repens*), timothy (*Phleum pratense*), orchardgrass (*Dactylis glomerata*), colonial bentgrass (*Agrostis tenuis*), and patches of reed canarygrass (Table 7.2-3). Other non-native species scattered throughout the area include cocklebur (*Xanthium strumarium*), common dandelion (*Taraxacum officinale*), and climbing nightshade (*Solanum dulcamara*).

Three emergent wetlands are present at the Auburn site (totalling about 19.5 acres (see Figure 7.2-2). The wetlands are dominated by non-native pasture grasses that include meadow foxtail, reedtop, colonial bentgrass, quackgrass, tall fescue, common velvetgrass, and patches of reed canarygrass. Other herbaceous species in the wetlands include soft rush and creeping buttercup. Along the western edge of the site are scattered black cottonwood and red alder trees.

A variety of shrubs and trees are scattered along a fence line at the southern boundary of the site. Shrubs found along the fenceline include Himalayan blackberry, vine maple, roses (*Rosa* sp.), snowberry (*Symphoricarpos albus*), and red-osier dogwood (*Cornus stolonifera*). Tree species

Table 7.2-3 Plant species observed on the mitigation site and adjacent riparian areas during delineation site visits in October 1995 and 2000.

	Scientific Name	Common Name	WIS ^a
Trees	<i>Alnus rubra</i>	Red alder	FAC
	<i>Crataegus douglasii</i>	Douglas hawthorn	FAC
	<i>Fraxinus latifolia</i>	Oregon ash	FACW
	<i>Populus trichocarpa</i>	Black cottonwood	FAC
	<i>Prunus emarginata</i>	Bitter cherry	FACU
Shrubs	<i>Acer circinatum</i>	Vine maple	FACU
	<i>Cornus stolonifera</i>	Red-osier dogwood	FACW
	<i>Corylus cornuta</i>	Beaked hazelnut	FACU
	<i>Cytisus scoparius</i>	Scots broom	NI
	<i>Populus trichocarpa</i> (saplings)	Black cottonwood	FAC
	<i>Rosa nutkana</i>	Nootka rose	FAC
	<i>Rosa pisocarpa</i>	Clustered wild rose	FAC
	<i>Rosa</i> sp.	Rose	
	<i>Rubus discolor</i>	Himalayan blackberry	FACU
	<i>Rubus laciniatus</i>	Evergreen blackberry	FACU
	<i>Rubus ursinus</i>	Pacific blackberry	FACU
	<i>Salix</i> spp.	Willow	FACW
	<i>Salix scouleriana</i>	Scouler willow	FAC
	<i>Symphoricarpos albus</i>	Snowberry	FACU
	Herbs	<i>Agropyron repens</i> *	Quackgrass
<i>Agrostis alba</i>		Redtop	FACW
<i>Agrostis tenuis</i> *		Colonial bentgrass	FAC
<i>Alopecurus geniculatus</i>		Water foxtail	OBL
<i>Alopecurus pratensis</i> *		Meadow foxtail	FACW
<i>Cirsium arvense</i> *		Canada thistle	FACU
<i>Cirsium vulgare</i> *		Bull thistle	FACU
<i>Dactylis glomerata</i> *		Orchardgrass	FACU
<i>Dipsacus sylvestris</i>		Teasel	FAC
<i>Eleocharis palustris</i>		Creeping spikerush	OBL
<i>Epilobium ciliatum</i>		Willow-herb	FACW
<i>Equisetum arvense</i>		Field horsetail	FAC
<i>Festuca arundinacea</i> *		Tall fescue	FAC
<i>Festuca rubra</i>		Red fescue	FAC+
<i>Geranium</i> spp.		Crane's-bill	FACU
<i>Holcus lanatus</i> *		Common velvetgrass	FAC
<i>Juncus effusus</i>		Soft rush	FACW
<i>Juncus</i> spp.		Rush	FACW
<i>Lolium perenne</i>		Perennial rye grass	FACU
<i>Lotus corniculatus</i>		Birds foot trefoil	FAC
<i>Phalaris arundinacea</i> *	Reed canarygrass	FACW	

Table 7.2-3. Plant species observed on the mitigation site and adjacent riparian areas during delineation site visits in October 1995 and 2000 (continued).

Scientific Name	Common Name	WIS ^a
<i>Phleum pratense</i> *	Timothy	FAC
<i>Phragmites communis</i>	Common reed	FACW
<i>Plantago lanceolata</i>	English plantain	FAC
<i>Poa pratensis</i> *	Kentucky bluegrass	FAC
<i>Polystichum munitum</i>	Sword fern	FACU
<i>Ranunculus repens</i>	Creeping buttercup	FACW
<i>Rumex crispus</i>	Curly dock	FAC
<i>Scirpus acutus</i>	Hard-stem bulrush	OBL
<i>Solanum dulcamara</i> *	Climbing nightshade	FAC
<i>Symphoricarpos albus</i>	Snowberry	FACU
<i>Tanacetum vulgare</i> *	Common tansy	UPL
<i>Taraxacum officinale</i>	Common dandelion	FACU
<i>Trifolium pratense</i>	Red clover	FACU
<i>Typha latifolia</i>	Common cattail	OBL
<i>Xanthium strumarium</i>	Cocklebur	FAC

* Dominant species on portions of the site.

^a Wetland Indicator Status (Table 7.2-4).

Table 7.2-4. Wetland indicator status.

Category	Symbol	Definition
Obligate Wetland Plants	OBL	Obligate wetland plants occur almost always (estimated probability >99%) in wetlands under natural conditions, but may also occur rarely (estimated probability <1%) in non-wetlands.
Facultative Wetland Plants	FACW	Facultative wetland plants usually occur (estimated probability 67% to 99%) in wetlands, but may also occur (estimated probability 1% to 33%) in non-wetlands.
Facultative Plants	FAC	Facultative plants with a similar likelihood (estimated probability 33% to 67%) of occurring in wetlands or non-wetlands.
Facultative Upland Plants	FACU	Facultative upland plants usually occur (estimated probability 67% to 99%) in non-wetlands, but also occur (estimated probability 1% to 33%) in wetlands.
Obligate Upland Plants	UPL	Upland plants occur almost always (estimated probability >99%) in non-wetlands under natural conditions.
	+	Used in conjunction with a category to indicate a somewhat greater probability to occur in wetlands.
	-	Used in conjunction with a category to indicate a somewhat lower probability to occur in wetlands.

Source: Environmental Laboratory (1987)

present in this area are Douglas hawthorn (*Crataegus douglasii*), Oregon ash (*Fraxinus latifolia*), and black cottonwood. The herbaceous community in this area is dominated by reed canarygrass.

In the summer of 1998, the northern one-fourth of the property was plowed and disced by a farmer leasing the land to the north.²⁰ This portion of the site is currently dominated by pasture grasses such as tall fescue (*Festuca arundinacea*) and perennial ryegrass (*Lolium perenne*), and weedy forbs such as bull thistle (*Cirsium vulgare*) and willowherb (*Epilobium ciliatum*).

Hydrology

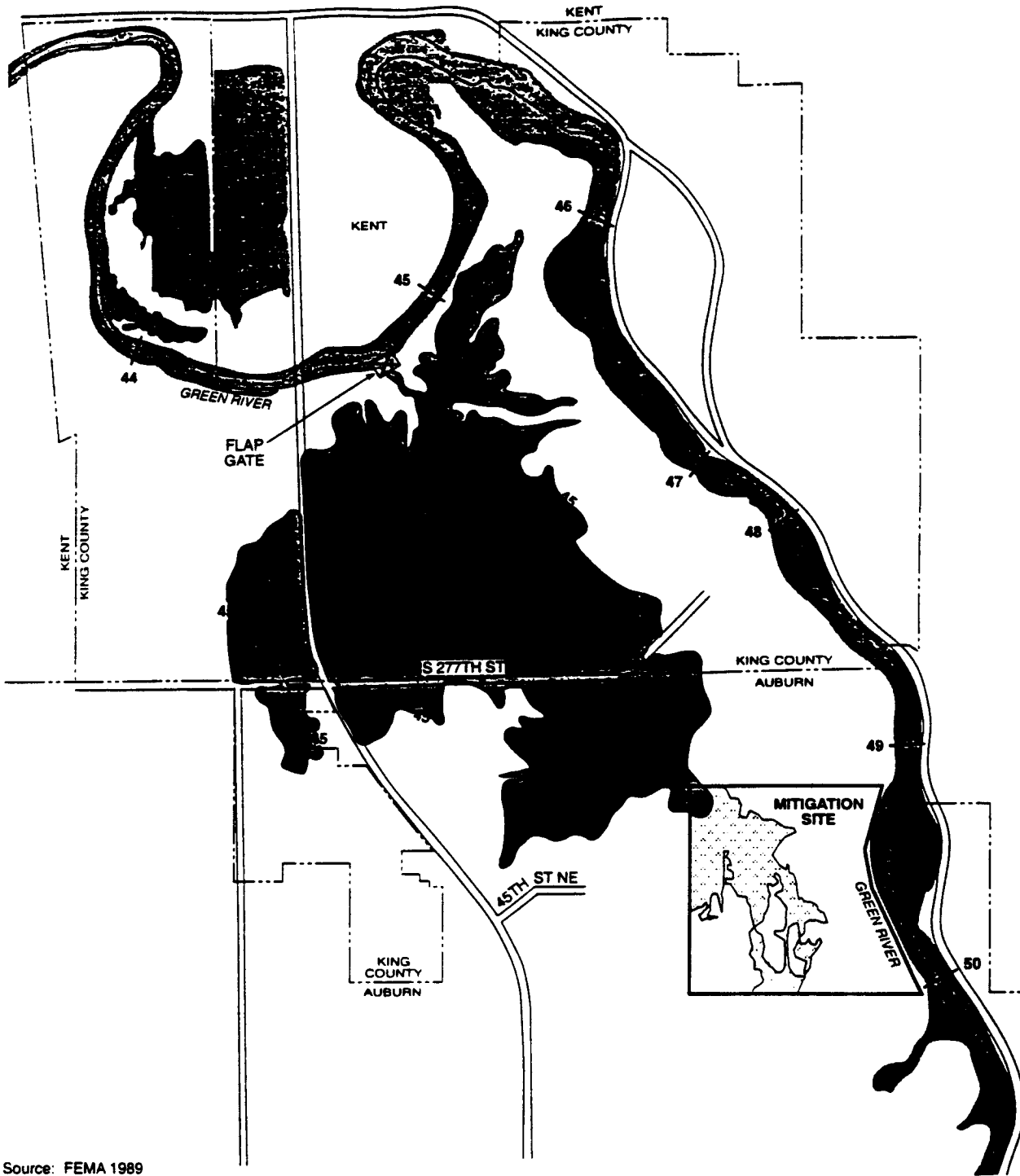
There are no natural surface water features on the mitigation site. Two streams, the Green River and Auburn Creek, are located near the mitigation site. The Green River flows from south to north about 100 to 150 ft east of the mitigation site. At this location, the river base elevation is about 12 to 15 ft below the site elevation. The river channel consists of a steep bank, largely vegetated with red alder and black cottonwood saplings. North of the mitigation site and north of South 277th Street, King County sensitive areas maps (King County 1990) shows an intermittent stream, Auburn Creek (see Figure 7.2-1). This stream drains pasture and farmland and flows into the Green River about 1 mile north of the mitigation site. At the confluence of Auburn Creek and the Green River, a small dike, culvert, and flap gate provide flood control.

Overland flow enters the site through a wetland drainageway, or shallow swale, that crosses the middle of the site. For short periods following heavy rainfall, this shallow swale contains surface flows that convey water from south to north across the site. This shallow drainage swale is connected to the 100-year floodplain of the Green River at the very northwest corner of the site (Figure 7.2-4). The eastern portion of the mitigation site is not within the 100-year floodplain of the Green River because the eastern edge of the site is several feet higher than the 100-year flood elevation of the river (See Figure 7.2-4). A drainage ditch on the mitigation site conveys stormwater and surface water runoff from the northwestern portion of the site to other ditches along South 277th Street. This water eventually flows into the Green River via Auburn Creek.

Since September 1995, the groundwater hydrology of the site has been monitored using shallow groundwater monitoring wells. Three representative wells are presented in Figures 7.2-5 through 7.2-7. The well data indicate groundwater levels that are within 18 inches of the surface at a number of locations, and generally within 36 to 24 inches of the soil surface for extended periods of time during the late fall, winter and early spring months. Wetlands on the mitigation site appear to be largely supported by this seasonally high groundwater table. In addition, wetland hydrology is supported by on-site precipitation that perches in the low permeability soils, resulting in saturated soils and extensive areas of shallow surface water ponding during the rainy season (See Figures 7.2-5 through 7.2-7).

At all well sites, groundwater elevations were lowest in late summer and early fall. Groundwater elevations were highest during and immediately after winter and early spring rains. Groundwater monitoring data show that following early fall precipitation (October, November) and subsequent soil saturation, groundwater elevations on the mitigation site rise by approximately 5 to 8 ft (see Figures 7.2-5 through 7.2-7). Groundwater elevations fall slowly during periods of low precipitation. The changes in groundwater elevation in response to precipitation are largely independent of variations in surface water elevation in the Green River, because the river elevation is typically below the groundwater levels observed on the site (Figure 7.2-8).

²⁰ The Port did not authorize this activity and the Port's property was not planted.






Source: FEMA 1989

Port of Seattle/Natural Resource Mitigation Plan/556-2912-001/01(03) 12/00 (K)

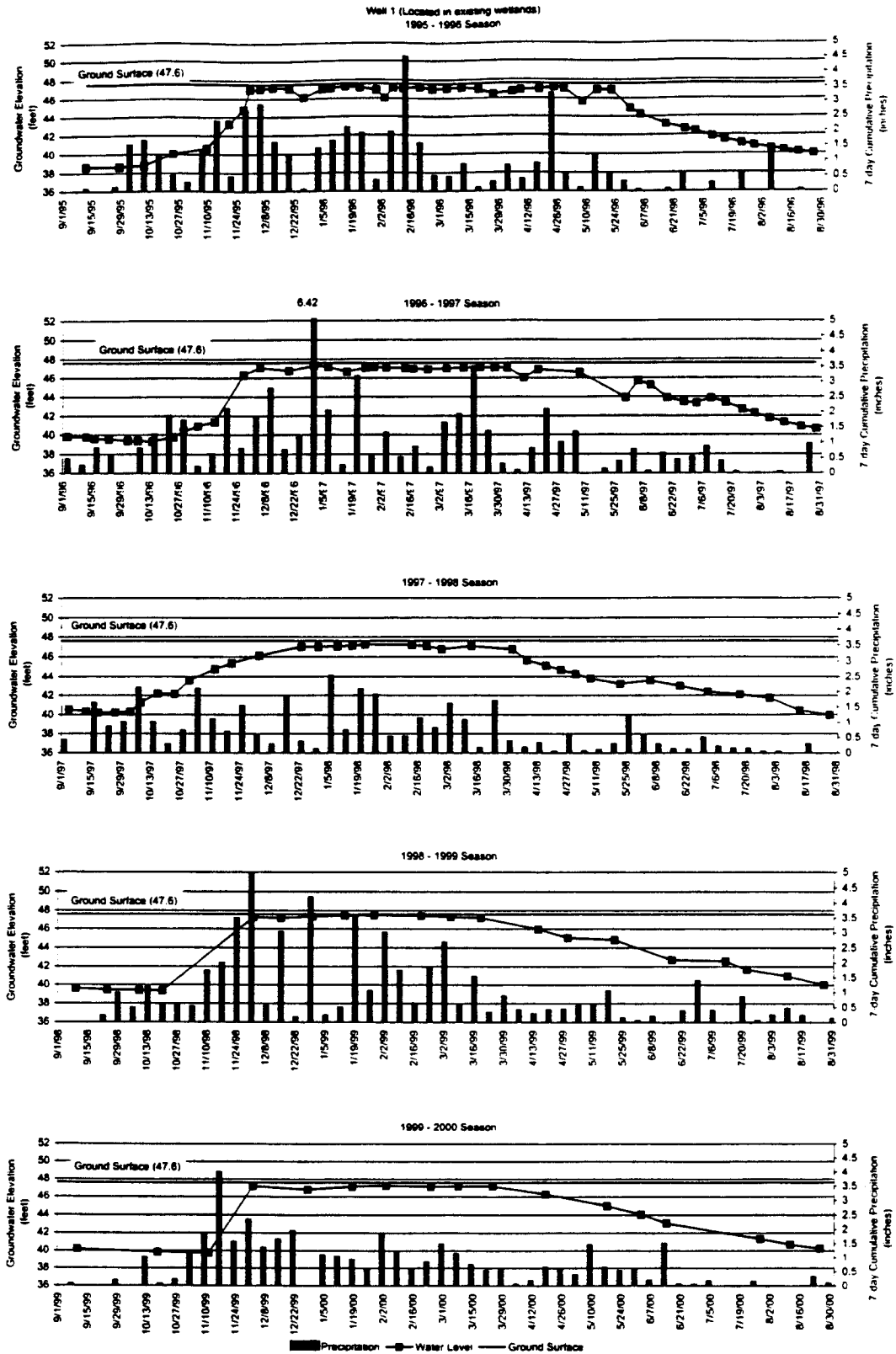


NOT TO SCALE

-  Existing Wetland
-  100 Year Floodplain
-  50 Flood Elevations

**Figure 7.2-4
100-Year Floodplains On and
Near the Proposed Wetland
Mitigation Site**

AR 048867



**Figure 7.2-5
Variations in Groundwater (Monitoring Well 1)
and Daily Precipitation**

Drawn by VMP, Inc.

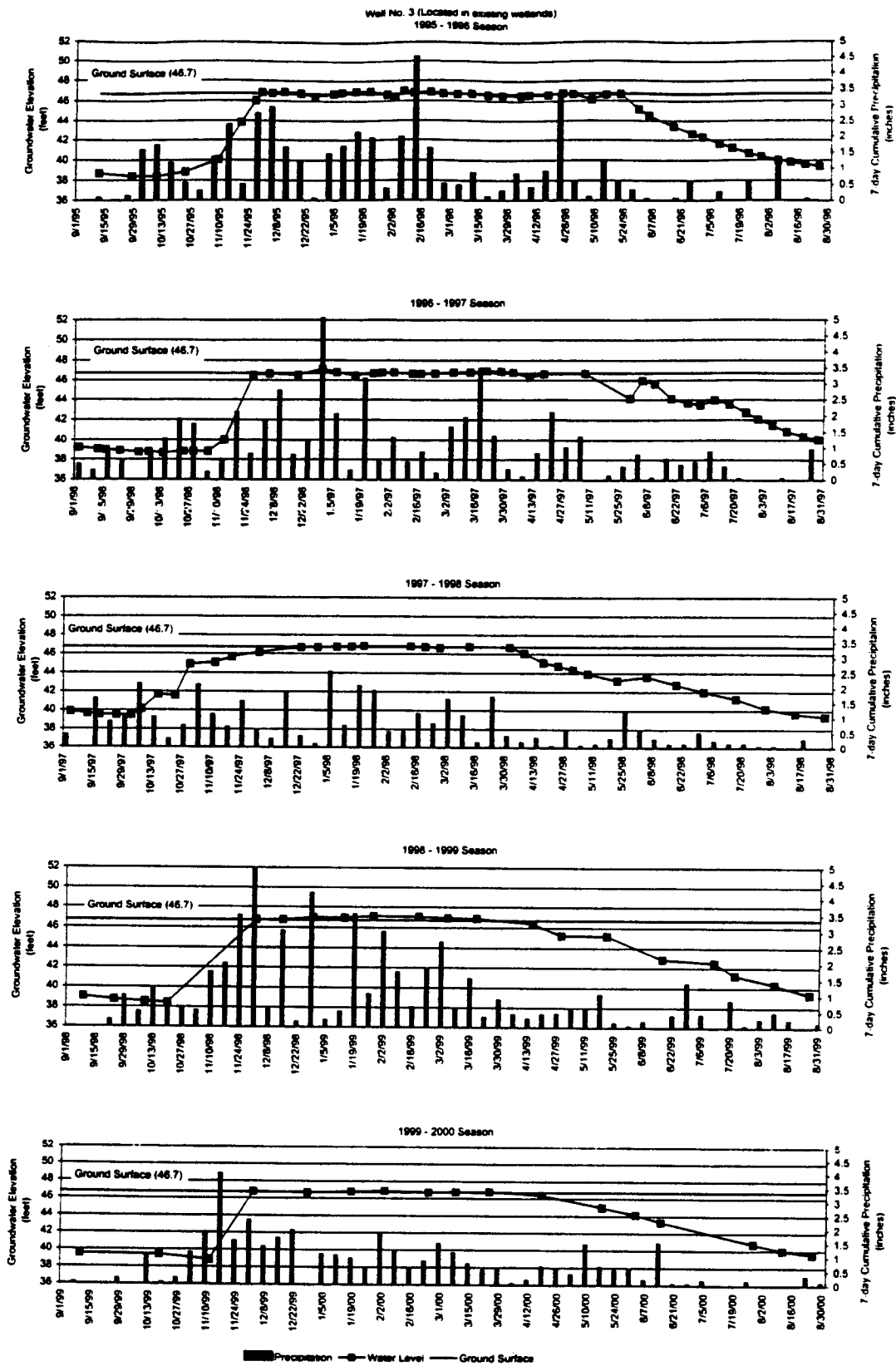
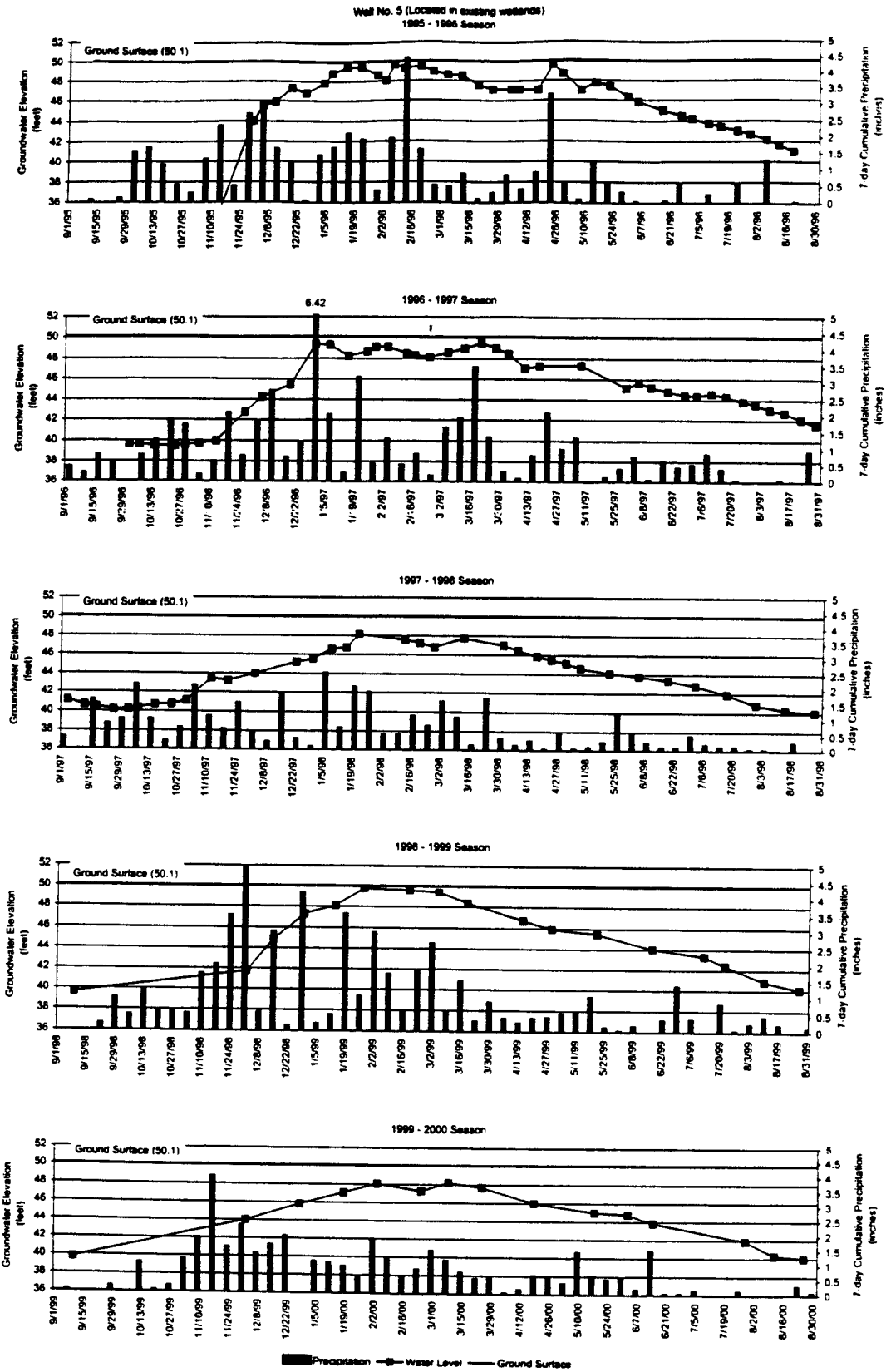


Figure 7.2-6
Variations in Groundwater (Monitoring Well 3)
and Daily Precipitation



**Figure 7.2-7
Variations in Groundwater (Monitoring Well 5)
and Daily Precipitation**

rhare for V&M&P, et

AR 048870

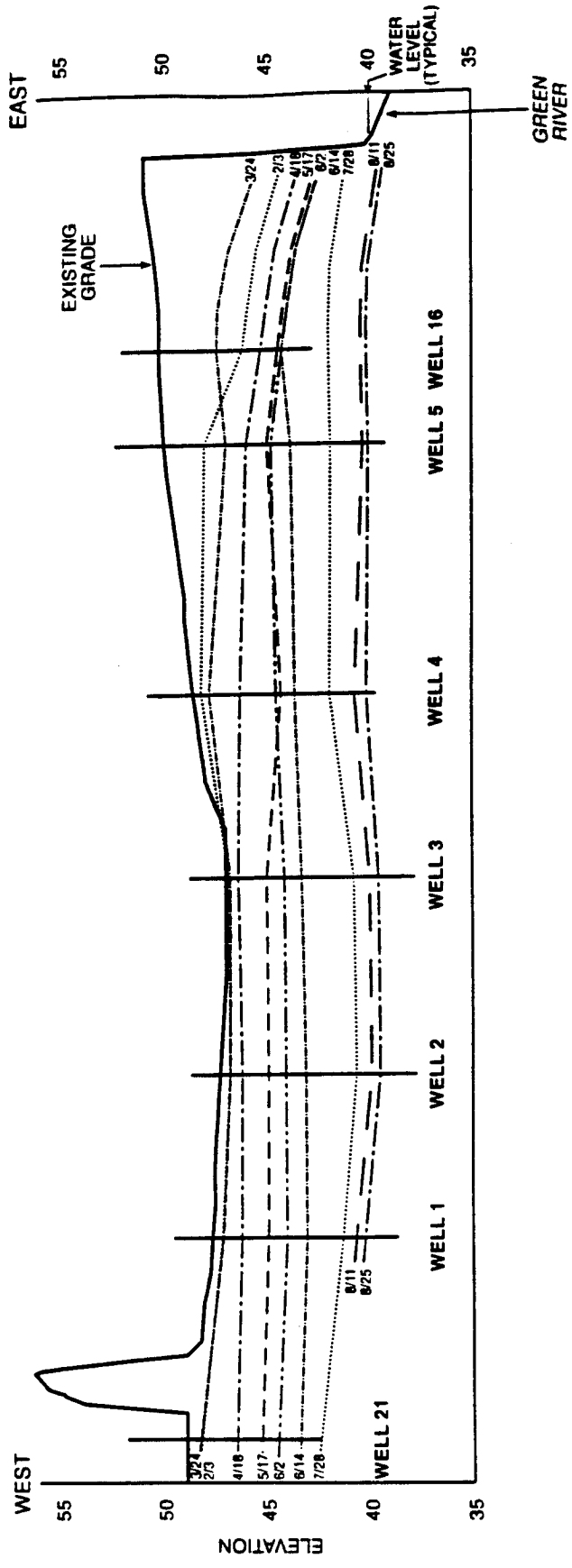
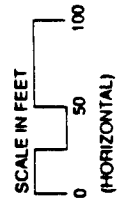


Figure 7.2-8
Cross Section of
Groundwater Elevations
(February-August 2000) at
the Wetland Mitigation Site

Port of Seattle/Natural Resources Mitigation Plan/556-2912-00/101(03) 1200 (K)

- 2/3
- 3/24
- 4/18
- 5/17
- 6/2
- 6/14
- 7/28
- 8/11
- 8/25



Well data indicate that groundwater in the mitigation area is perched over low permeability clay layer and generally flows northwesterly in the same direction as surface water (Figure 7.2-9 through 7.2-11). A groundwater divide occurs approximately 700 ft west of the Green River (see Figure 7.2-9). East of this divide, groundwater flows eastward towards the river. West of the divide water flows to the northwest.

Soils

The soils on the mitigation site are alluvial in origin, developed from material deposited on the site by the Green River. The surficial layers of these soils are a complex of silty mineral soils, frequently with lenses of fine sand intermixed. Plowing has mixed the surficial layers of soil, typically to a depth of 9 to 10 inches.

The King County Soil Survey (Snyder et al. 1973) maps soils on the site as the poorly drained Briscot, and Oridia silt loams, and the somewhat poorly drained Renton silt loam (Figure 7.2-12; Table 7.2.5). Briscot, Oridia, and Renton silt loams are designated as hydric soils on the King County, Washington Hydric Soil List (NRCS 2000).²¹

Table 7.2-5. Drainage characteristics of soils occurring on the mitigation site.

Soil Series ¹	Drainage Class	High Water Table			Flooding		
		Permeability (in/hr) ²	Depth (ft)	Months	Frequency	Duration	Months
Briscot	Poorly	0.63-2.0	1 to -1	Nov-Apr	Occasional	Brief	Dec to Feb
Oridia	Poorly	0.20-2.0	1 to 3	Nov-Apr	Occasional	Brief	Nov to Apr
Renton	Somewhat poorly	2.0-6.3	1 to 1.5	Nov-Apr	Common	Brief	Nov to Apr

Source: U.S. Department of Agriculture (1973).

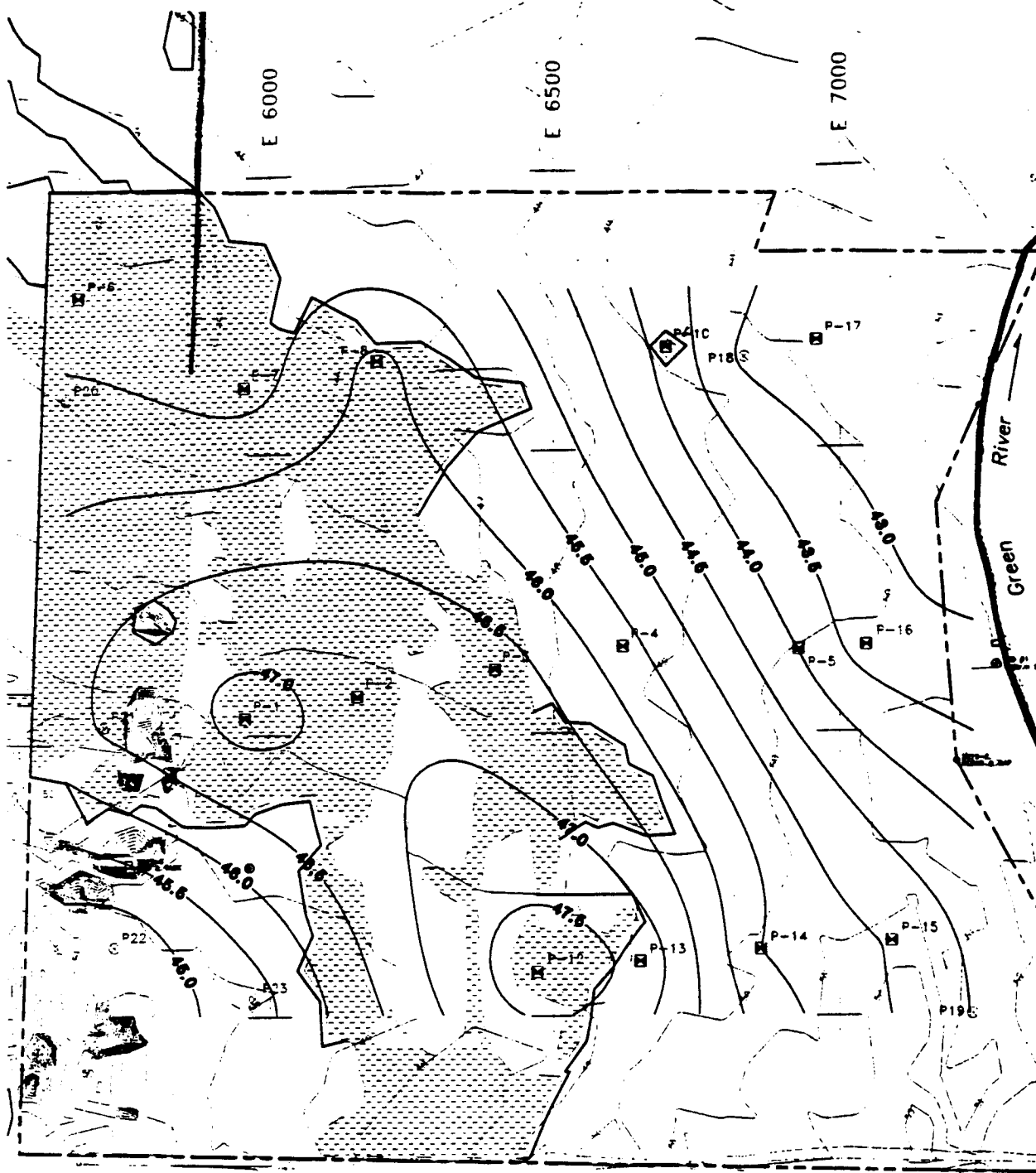
¹ All soils are classified as hydric (wetland); however, evaluation of on-site conditions indicate non-hydric soil inclusions occur throughout the site.

² Within the top 20 inches of soil.

The published soil descriptions are generally consistent with the results of the laboratory and field analysis of soil performed by Parametrix in October 1995 and soil data collected in the fall of 2000 (Parametrix 2000c). Field observations, and analytical test results indicate that two general soil profiles occur on the proposed mitigation site: a wetland soil profile and an upland soil profile (Figure 7.2-13).

The wetland soil profile generally consists of a 6-inch organic layer that covers a 72-inch layer of clayey silt (see Figure 7.2-13). The first 24 inches of the clayey silt are uniform, with mottles dispersed throughout. This uniformity is likely a result of past plowing. Below the uniformly mixed silt, the soil is stratified to layers of gray silt and sandy silt that grades to a sandy silt layer at a depth of about 72 inches. Below the sandy silt are 12 to 16 inches of very compact clayey silt. Below the clayey silt layer, the soil grades to a uniformly fine sand layer. The permeability of the clay silt varies between 0.001 to 0.003 inches/hour (determined at two locations). Because of the thickness of the clayey silt layer and the absence of an underlying fine sand (as found in the adjacent upland soils described below), these soils drain slowly, allowing hydric soil characteristics to develop.

²¹ Because the soils on the site are mapped as hydric, and farming activities including ditching have occurred, mitigation on the site could be considered restoration. Because the Port's mitigation establishes some wetland classed that probably did not historically occur on the site, the term "creation" is used for mitigation in upland portions of the site.



FILE: 29121404d
 DATE: 12/14/00

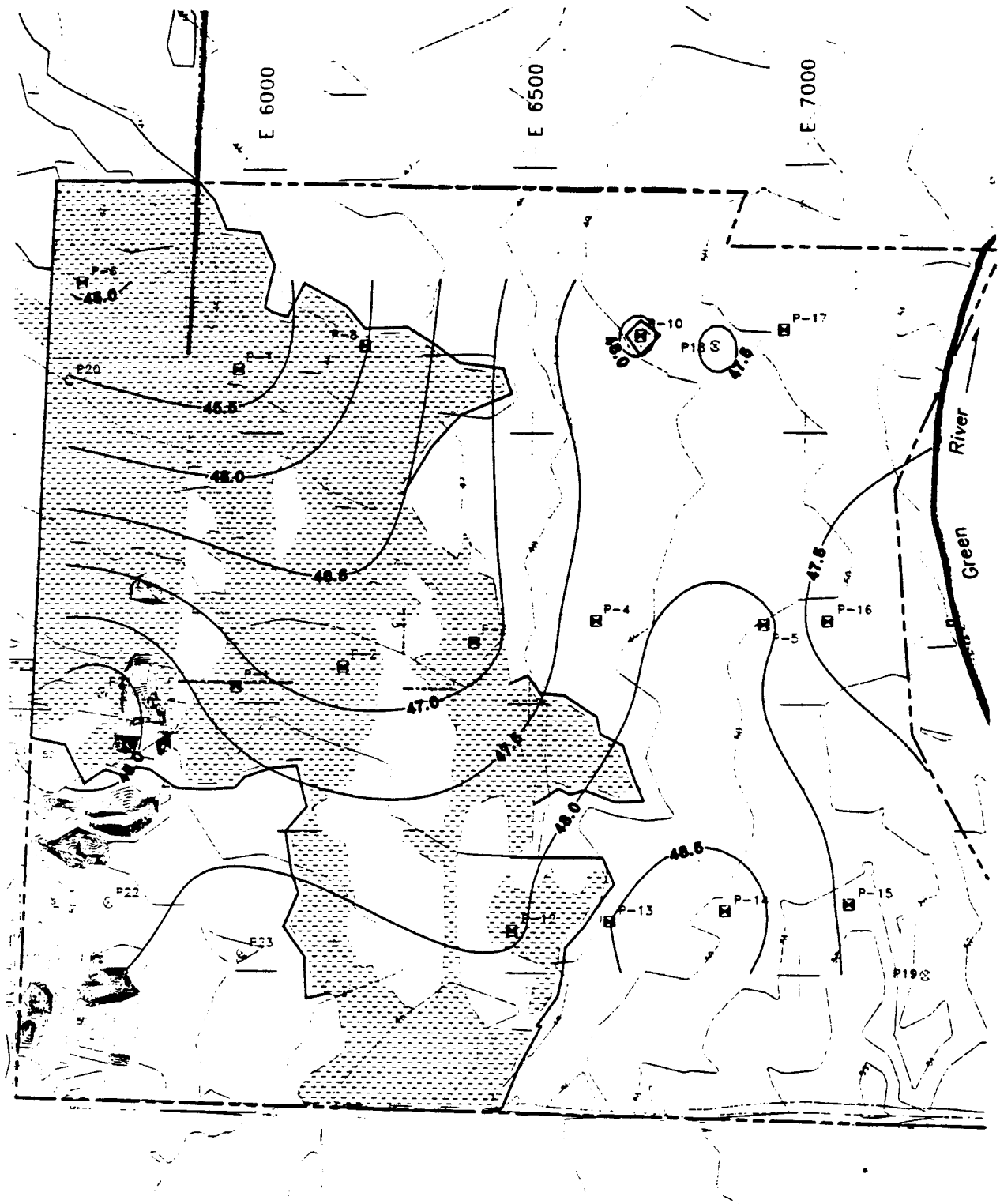
LEGEND:



-  Groundwater Contour and Elevation
-  Existing Wetland
-  Piezometer Locations and Number
-  Existing Ground Surface Contour and Elevation

**Figure 7.2-9
 Groundwater Elevations on the
 Auburn Wetland Mitigation Site
 (December 2, 1999)**

AR 048873



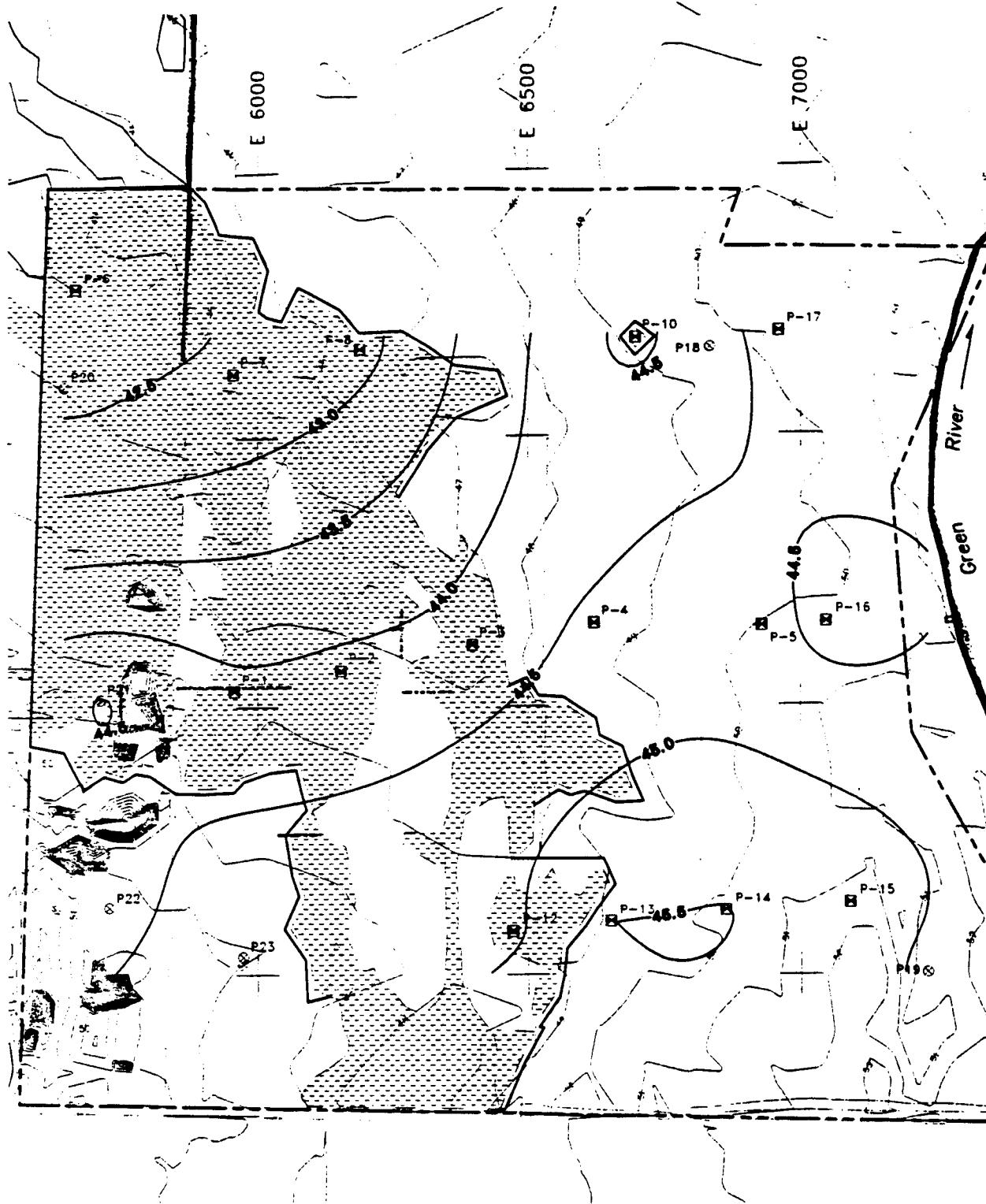
FILE 29121404b
DATE 12/14/00

LEGEND:



-  Groundwater Contour and Elevation
-  Existing Wetland
-  Piezometer Locations and Number
-  Existing Ground Surface Contour and Elevation

**Figure 7.2-10
Groundwater Elevations on the
Auburn Wetland Mitigation Site
(March 8, 2000)**



FILE: 29121404c
 DATE: 12/14/00

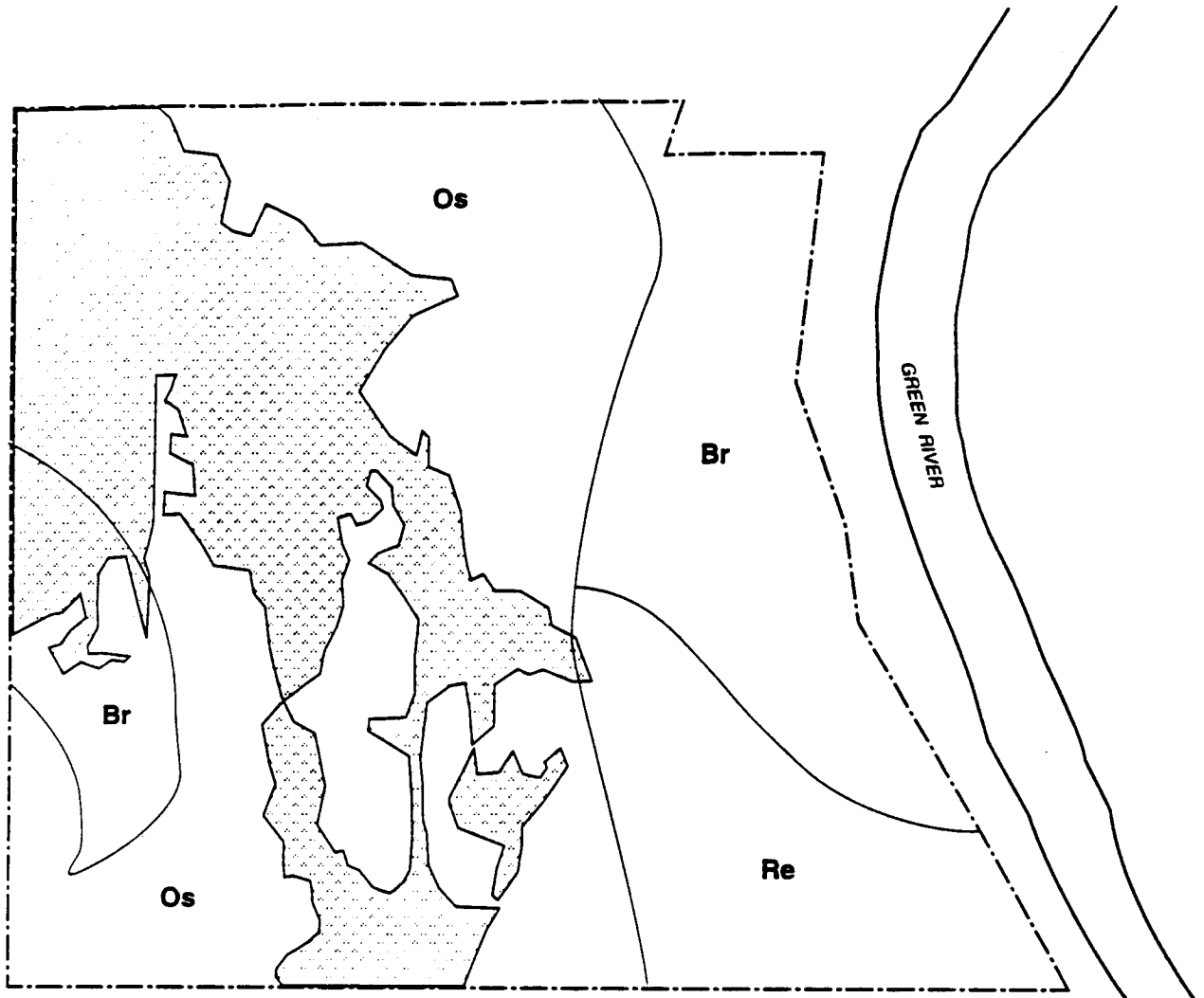
LEGEND:



- 44.5 — Groundwater Contour and Elevation
- Existing Wetland
- P20 Piezometer Locations and Number
- 48.0 — Existing Ground Surface Contour and Elevation

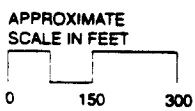
Figure 7.2-11
Groundwater Elevations on the
Auburn Wetland Mitigation Site
(June 2, 2000)

AR 048875



Source: USDA 1973

Port of Seattle/Natural Resource Mitigation Plan/556-2912-001/01(03) 12/00 (K)



Re Renton Silt Loam
Os Oridia Silt Loam
Br Briscot Silt Loam



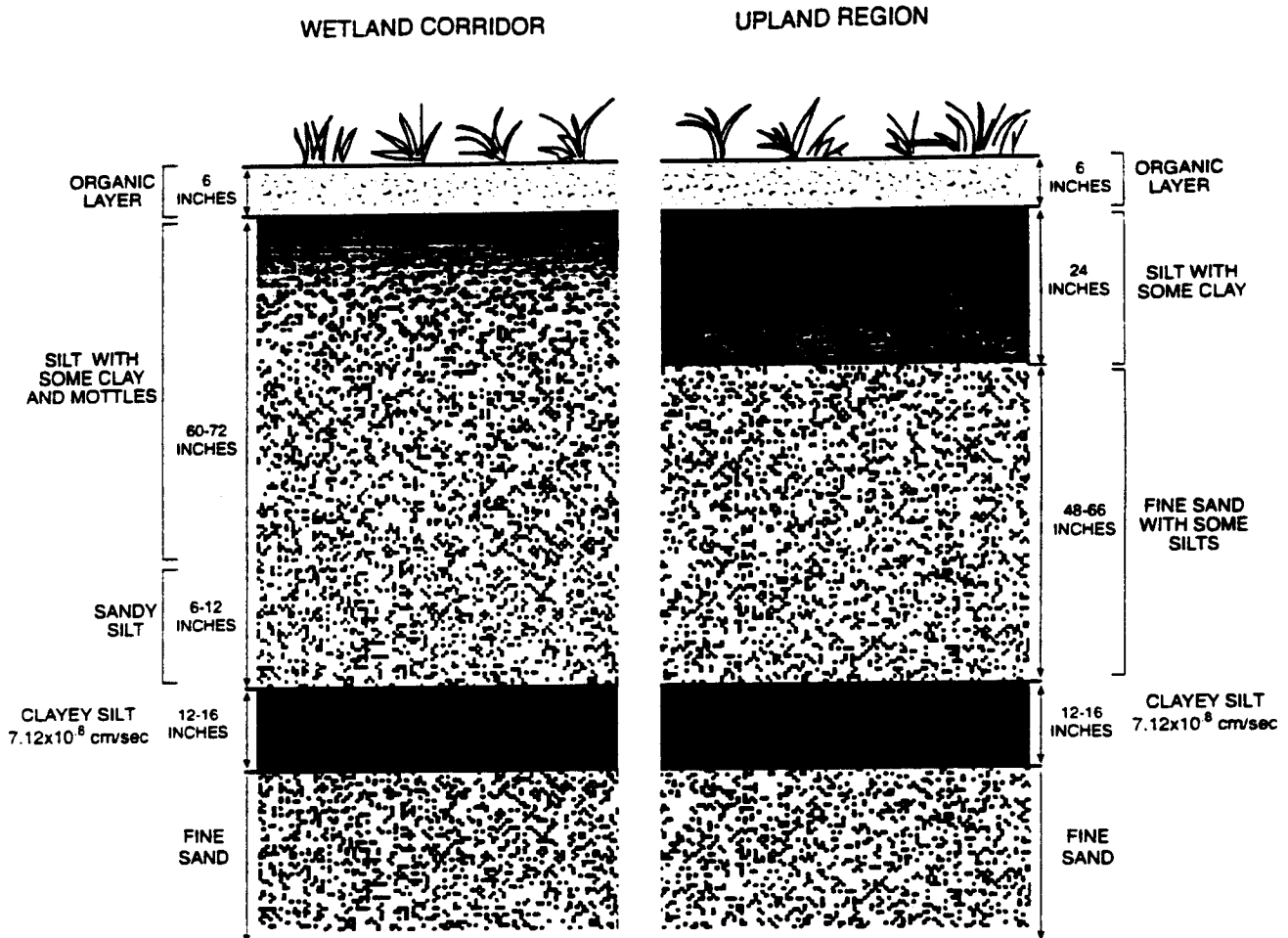
Existing Wetland



Site Boundary (Approximate)

Figure 7.2-12
Soil Types on the
Proposed Wetland
Mitigation Site

AR 048876



POS Natural Resource Mitigation/556-2912-001/01/03/ 12/00

Data Compiled by Parametrix

**Figure 7.2-13
Typical Soil Profiles at
the Wetland Mitigation Site**

AR 048877

In the upland portion of the site, including the areas outside the existing wetlands that would be graded under the proposed mitigation design, the upper 30 inches of soil is similar to the wetland soils described above (see Figure 7.2-13). A 6-inch topsoil layer is present over a 24-inch, uniformly mixed layer of clayey silt with dispersed mottles. Below 30 inches a 36- to 66-inch layer of uniform gray, fine sand (with some silt) is found. A 6- to 8-inch-thick clayey silt layer was encountered between the 72- and 96-inch depth. Below this clayey silt, the soil returns to a uniform fine sand. The sand layer located near the soil surface and a relatively thin clay silt layer in these soils allow them to drain more rapidly than the wetland soils.

7.2.5.2 Environmental Site Assessment

A Phase I Site Assessment of the mitigation property was conducted in December 1995 (Parametrix 1995). The report was prepared according to guidelines described in *American Society for Testing and Materials (ASTM) Standard Practice for Environmental Site Assessments: Phase I Environmental Site Assessment Process (ASTM E 1527)*. The assessment indicates no environmental conditions of concern associated with past or current use of the site and adjacent properties.

7.2.5.3 Wildlife Habitat

The mitigation site consists of abandoned agricultural land that is dominated by grasses and forbs. The properties immediately adjacent to the site to the north and south are actively farmed. West of the site, wildlife habitat has been largely eliminated by residential development. No permanent aquatic habitat is found on the site, although the Green River provides aquatic habitat near the eastern site boundary. Forested slopes along the east bank of the Green River provide habitat connectivity to riparian and other wetland systems, and forested areas. The WDFW Priority Habitats and Species database identifies the palustrine emergent wetland that bisects the site as a priority habitat (all wetlands are considered priority habitat by WDFW).

Habitat quality of the existing wetlands and the adjacent grassy uplands is relatively low due to a number of factors. The relatively uniform pasture grass vegetation is dominated by non-native plant species, lacks structural diversity, has a low plant species diversity, and lacks habitat complexity. Small mammals use the area for feeding and breeding. The site may provide foraging habitat for raptors, such as Northern harriers and red-tailed hawks. Apart from the tall pasture grasses there is a general lack of cover from predators, and a lack of habitat complexity (e.g., pits and mounds, large woody debris) that provides for breeding, resting, and/or thermal cover for small mammals. For most passerine bird species, the site lacks habitat structure for nesting, protection from predators, thermal cover, or perching. A narrow band of shrub vegetation along the southern boundary provides limited forage and perching habitat. Amphibian habitat on the site is currently limited by a lack of seasonally inundated pools, forest cover, and large woody debris.

Tracks or scat of coyote, mink, deer, and raccoon were observed on or near the mitigation site during the site assessment. Species observed on the site include kingfisher, short-eared owl, barn owl, common snipe, red-tailed hawk, common yellowthroat, and mallard duck. Most of these species appeared to be most abundant in the eastern portion of the site next to the Green River.

7.2.5.4 Functional Changes Anticipated at the Auburn Mitigation Site

The off-site wetland mitigation site is designed to wetland habitat functions affected by implementation of the proposed Master Plan Update improvements. The proposed design of the mitigation site would also provide additional mitigation for species using wetland buffer areas and other upland habitats at the airport.

Wildlife Habitat

Construction of the forested, shrub, and emergent wetlands would create conditions that provide habitat for a variety of wildlife species (Table 7.2-6). Habitat structure and availability would change as vegetation matures over the next several decades, and the wildlife species using the site are expected to change over time (Table 7.2-7). Plant species proposed for the wetland mitigation area and their values to various forms of wildlife are presented in Table 7.2-8.

Post-construction habitat structure in proposed forested wetlands would be similar to a regenerating forest, and would develop mature forest habitat attributes after several decades (Figure 7.2-14). The shrub understory would enhance the development of habitat structure. Songbird use in early stages of habitat development would include foliage and bark-gleaning species (kinglet, chickadee, bushtit, vireo) that forage in the area. In later years, Oregon ash, vine maple, willows, redcedar, and western hemlock seed production would be used by additional songbird species. Small mammals would likely forage on the forest floor for seeds and invertebrates, even though optimal habitat conditions would not occur for one or more decades. As a tree canopy begins to develop, it would provide nesting habitat and cover for predator avoidance.

Post-construction habitat structure in shrub wetlands would generally be similar to that of forested systems during the first several years of development (see Figure 7.2-14). However, since shrub communities would periodically be flooded, ground-dwelling animals would be less common. The shrub community would reach functional maturity in 15 to 25 years following planting (see Figure 7.2-14).

Emergent communities would provide resting and foraging habitat for shore and water birds within 1 year of planting. After 2 to 3 years, most of the intended wildlife functions should be present, and in the following 5 to 10 years, relatively mature communities should be present.

Tree-nesting songbirds (such as thrushes, vireos, and warblers) are expected to use horizontal branches for nesting when the canopy closes enough to provide cover. Leaf litter and forest detritus would begin to accumulate, providing habitat for the invertebrates (Pennak 1989) that amphibians (such as ensatina), small mammals, and ground-foraging birds feed on. Small mammals, in turn, are likely to become food for predators, such as barred owls. Over several decades, disease or competition for light would result in mortality. Dead and decaying trees would provide woody debris and snag habitat for flickers, woodpeckers, and small cavity-nesting birds.

Table 7.2-6. Wildlife species expected to occur in the Auburn wetland mitigation site after construction.

Common Name	Habitat Type					
	Permanently Flooded Emergent Wetland	Seasonally Flooded Emergent Wetland	Shrub Wetland	Forested Wetland	Riparian Forest	Abandoned Agricultural Land
Amphibians						
Northwestern salamander	X	X		X	X	
Long-toed salamander		X	X	X	X	
Pacific giant salamander	X			X	X	
Rough-skinned newt	X	X			X	
Ensatina					X	
Western toad	X	X				
Pacific chorus frog	X	X	X	X	X	
Red-legged frog	X	X	X	X	X	
Bullfrog ¹	X					
Reptiles						
Common garter snake	X	X	X	X	X	
Birds						
Great blue heron	X	X	X	X		
Canada goose	X	X				X
Green-winged teal	X	X				X
Mallard	X	X	X			X
Northern pintail	X	X				X
American pigeon	X	X				X
Osprey					X	
Bald eagle					X	
Northern harrier	X	X				X
Red-tailed hawk				X	X	X
Killdeer	X	X				X
Common snipe	X	X				
Herring gull	X					X
Rock dove ¹						X
Western screech-owl				X	X	
Rufous hummingbird					X	X
Belted kingfisher	X					
Downy woodpecker				X	X	
Northern flicker				X	X	
Pileated woodpecker				X		
Willow flycatcher				X	X	
American/northwestern crow	X	X		X	X	X
Black-capped chickadee				X	X	
Bushtit				X	X	

Table 7.2-6. Wildlife species expected to occur in the Auburn wetland mitigation site after construction (continued).

Common Name	Habitat Type					
	Permanently Flooded Emergent Wetland	Seasonally Flooded Emergent Wetland	Shrub Wetland	Forested Wetland	Riparian Forest	Abandoned Agricultural Land
Bewick's wren			X	X	X	
Winter wren					X	
Marsh wren	X		X			
Golden-crowned kinglet					X	
Ruby-crowned kinglet				X	X	
American robin		X		X	X	X
Varied thrush				X	X	
European starling ¹				X	X	X
Yellow warbler				X	X	
Yellow-rumped warbler				X	X	
MacGillivray's warbler			X	X	X	
Common yellowthroat	X		X			
Wilson's warbler				X	X	
Rufous-sided towhee				X	X	
Fox sparrow				X	X	
Song sparrow	X	X	X	X	X	X
Dark-eyed junco				X	X	
Red-winged blackbird	X	X	X			X
Brown-headed cowbird	X	X	X	X	X	X
American goldfinch				X	X	
House sparrow ¹						X
Mammals						
Vagrant shrew		X	X	X	X	
Pacific water shrew	X	X				
Shrew-mole					X	
Pacific mole						X
Pacific jumping mouse				X	X	
Raccoon	X	X	X	X	X	
Mink	X	X	X	X	X	
Striped skunk					X	X
Coyote			X	X	X	
Red fox			X	X	X	

¹ Introduced species.

Table 7.2-7. Potential wildlife use of constructed wetland habitats.

Wildlife Types	Years After Planting											
	Emergent Wetland				Shrub Wetland				Forested Wetland			
	0 to 2	2 to 5	5 to 15	>15	0 to 2	2 to 5	5 to 15	>15	0 to 2	2 to 10	10 to 25	>25
Mammals												
Shrews and mice	F	F	F	F	F	B/F	B/F	B/F	F	B/F	B/F	B/F
Squirrels		F	F	F	F	F	F	F	F	F	B/F	B/F
Raccoons and mink		F	F	F	F	F	F	F	F	F	B/F	B/F
Fox and coyote		F	F	F	F	F	F	F	F	F	F	F
Bats	F	F	F	F	F	F	F	F	F	F	F	F
Deer	F	F	F	F	F	F	F	F	F	F	F	F
Birds												
Shrub-nesting songbirds	F	F/M	F/M	F/M	F/M	F/M	B/F/M	B/F/M	F/M	B/F/M	B/F/M	B/F/M
Swallows and swifts	F	F	F	F	F	F	F	F	F	F	F	B/F
Forest-dwelling songbirds									F/M	F/M	B/F/M	B/F/M
Cavity-nesting birds									F	F	F	B/F
Marsh-nesting songbirds	F	F	B/F	B/F	F	F	B/F	B/F	F	F	F	F
Raptors	F	F	F	F	F	F	F	F	F	F	F	B/F
Wading birds		F/M	F/M	F/M	F/M	F/M	F/M	F/M	F/M	F/M	F/M	F/M
Dabbling waterfowl		F/M	F/M	F/M	F/M	F/M	F/M	F/M	F/M	F/M	F/M	F/M
Diving waterfowl		F/M	F/M	F/M	F/M	F/M	F/M	F/M	F/M	F/M	F/M	F/M
Herpetofauna												
Reptiles		F	F	F	F	F	F	F	F	F	F	F
Terrestrial-breeding amphibians		F	F	F	F	F	F	F	F	F	B/F	B/F
Aquatic-breeding amphibians		F	B/F	B/F	B/F	B/F	B/F	B/F	F	F	B/F	B/F
Macroinvertebrates												
Aquatic insects	B/F	B/F	B/F	B/F	B/F	B/F	B/F	B/F	B/F	B/F	B/F	B/F
Gastropods												

B = Breeding
 F = Foraging
 M = Migration

Table 7.2-8. Plant species to be planted at the Auburn wetland mitigation site.

Plant Species		Wildlife	Description
Scientific Name	Common Name	Function	
Deciduous Trees			
<i>Acer macrophyllum</i>	Big-leaf maple	Forage	The seeds of big-leaf maple and Oregon ash are eaten by small mammals, songbirds, and game birds. Cascara and western crabapple fruit are persistent and offer good winter forage for pileated woodpeckers, thrushes, band-tailed pigeons, and other songbirds. The female catkins of alder, cottonwoods, and willows are used by foraging songbirds. New growth provides browse for medium and large mammals. Deciduous trees provide foraging habitat for hawking and foliage-gleaning insectivores. The leaf litter provides food for detritivores (which in turn are consumed by small mammals, amphibians, reptiles, and birds).
<i>Alnus rubra</i>	Red alder		
<i>Populus trichocarpa</i>	Black cottonwood		
<i>Rhamnus purshiana</i>	Cascara		
<i>Fraxinus latifolia</i>	Oregon ash		
<i>Malus fusca</i>	Pacific crabapple		
<i>Salix lasianдра</i>	Pacific willow		
Habitat			
Deciduous trees provide nesting habitat for birds, small mammals, and invertebrates; perching and roosting habitat for birds; and escape cover for prey species. Mature Oregon ash are vulnerable to heart rot and subsequent insect invasion, providing cavity nesting and roosting habitat. Leaf litter from deciduous trees is used as cover by amphibians and small mammals.			
Coniferous Trees			
<i>Picea sitchensis</i>	Sitka spruce	Forage	These coniferous trees provide seed forage for songbirds, game birds, mice, squirrels, voles, and shrews, as well as foraging habitat for hawking and foliage-gleaning insectivores. Deer, rabbit, and mountain beaver browse on new growth and young bark.
<i>Thuja plicata</i>	Western redcedar		
<i>Abies grandis</i>	Grand fir	Habitat	Evergreen vegetation provide breeding and roosting habitat for birds and small mammals. Coniferous heartwood often decays readily when attacked by fungi, resulting in hollow living trees which provide habitat for cavity-nesting and roosting species. The foliage provides year-round escape cover and thermal protection when deciduous foliage is lacking.
Shrubs			
<i>Salix sitchensis</i>	Sitka willow	Forage	Willow shrubs may be used as browse by deer and some small mammals. The female catkins provide forage for songbirds. Vine maple seeds are eaten by small birds and mammals.
<i>Salix hookeriana</i>	Hooker's willow		
<i>Salix scouleriana</i>	Scouler's willow		
<i>Acer circinatum</i>	Vine maple		
Natural Resource Mitigation Plan Seattle-Tacoma International Airport Master Plan Update			7-38

December 2000
556-2912-001 (03)

G:\DATA\working\91251212\10\mapa\9909\RAI\PC\error\errtbl\Matrix1.doc

Table 7.2-8. Plant species proposed for the Auburn wetland mitigation area (continued).

Scientific Name	Common Name	Wildlife		Description
		Function	Habitat	
				These shrubs provide dense multi-stem nesting habitat and escape cover for songbirds and small mammals. The leaf litter provides habitat for amphibians and detritivores.
<i>Cornus stolonifera</i>	Red-osier dogwood	Forage	Habitat	Hazelnut provides a mast crop and winter forage for game birds, deer, and small mammals. Twinberry, red elderberry, snowberry, and Indian plum fruit are an excellent food source for birds and mammals. Rose hips are a food source for songbirds, game birds, deer, small mammals, and rodents. The fruits are persistent and provide forage in the winter months. Salmonberries are eaten by songbirds, game birds, small mammals, deer, and some omnivores (fox, raccoon, etc.). Deer browse on the leaves, twigs, and fruit of all of these shrubs.
<i>Lonicera involucrata</i>	Twinberry			
<i>Oemleria cerasiformis</i>	Indian plum			
<i>Physocarpus capitatus</i>	Pacific ninebark			
<i>Rubus spectabilis</i>	Salmonberry			
<i>Rosa nutkana</i>	Nootka rose			
				The shrub structure provides nesting and escape cover for birds, mammals, and other prey species.
Herbaceous Species				
<i>Carex rostrata</i>	Beaked sedge	Forage	Habitat	The seeds of sedges and fruits of rushes are eaten by songbirds, game birds, and waterfowl, especially mallard and ring-necked ducks. The foliage is browsed upon by deer and small mammals. Bur-reed fruit and the young shoots of most emergent plants are forage for waterfowl and muskrat.
<i>Eleocharis palustris</i>	Common spike-rush			
<i>Scirpus microcarpus</i>	Small-fruited bulrush			
<i>Scirpus acutus</i>	Bulrush			
<i>Scirpus lacustris</i>	Hardstem bulrush			
<i>Spartanium emersum</i>	Narrow-leaf bur-reed			
				These species provide nesting materials and cover for songbirds, waterfowl, and small mammals. Shrews, mice, and voles use the ground cover for thermal protection and predator avoidance. In late winter and spring floods, the stems are used for breeding substrate by amphibians and invertebrates.
<i>Oenanthe sarmentosa</i>	Water parsley	Forage	Habitat	Some herbivores may browse on water parsley and smartweed. Water smartweed fruit are eaten by songbirds, game birds, deer, and rabbit. Dabbling and diving ducks feed on the foliage.
<i>Polygonum amphibium</i>	Water smartweed			

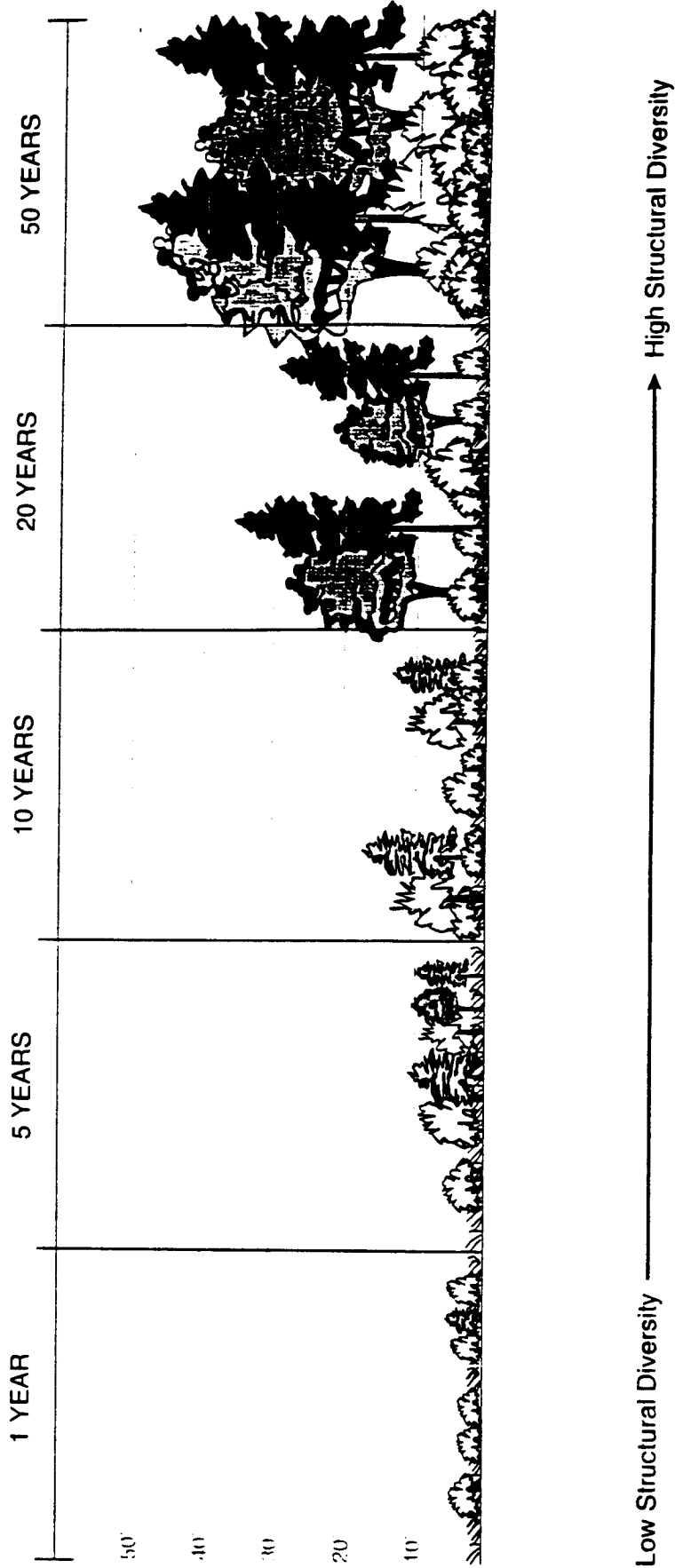
Table 7.2-8. Plant species proposed for the Auburn wetland mitigation area (continued).

Plant Species Scientific Name	Common Name	Wildlife	
		Function	Description
Grasses			
<i>Agrostis alba</i>	Redtop	Forage	Songbirds and rodents feed on all these grass seeds, while mannagrass and red fescue are grazed by waterfowl.
<i>Festuca rubra</i>	Red fescue		
<i>Glyceria</i> sp.	Mannagrass	Habitat	Grasses provide breeding and escape cover for small mammals. Grasses are used by many species for nest construction and lining.

Sources: Martin et al. (1951); Brown (1961); Payne and Bryant (1992)

Seed production by trees varies with maturity. Red alder and black cottonwood produce seeds at 4 to 10 years of age. Big-leaf maple, Douglas fir, and western redcedar produce seeds after 10 to 12 years of age. Oregon ash, Sitka spruce, and western hemlock produce large seed crops after about 20 years of growth.

YEARS FOLLOWING PLANTING



AR 048886

Figure 7.2-14
 Typical Successional Changes
 in Forested Wetland Vegetation
 Following Planting

The shrub and emergent wetlands should achieve stable habitat conditions earlier than the forested wetland community. Shrub wetland communities should produce forage and nesting opportunities within 2 to 10 years. Swainson's thrush and Wilson's warblers use moist shrub habitats for nesting and foraging. Berries produced by salmonberry, red elderberry, and red-osier dogwood are used by several insectivorous songbird species to supplement fall and winter diets (Ehrlich et al. 1988). Mink, shrews, and other small mammals would exploit these insect and aquatic invertebrate food sources. Wading birds, such as great blue herons and bitterns, can feed on small mammals and amphibians.

Amphibian use, however, would likely be limited by immigration rates because of the lack of existing amphibian habitat in the area. Some species, such as Pacific giant salamander, northwestern salamander, and rough-skinned newt, commonly migrate through terrestrial habitats and could use the mitigation site.

Although flooded emergent wetlands can provide substantial forage opportunities for ducks, habitat use would vary with proximity to upland predator cover. Waterfowl, which are wary of dense shrubs that allow predators to approach undetected, prefer interspersed flooded emergent vegetation and open water. Slough sedge (*Carex obnupta*), spike-rush (*Eleocharus palustris*), and horsetail are all species preferred by dabbling ducks and geese during migration (Payne and Bryant 1992). Narrow-leaf bur-reed (*Sparganium emersum*) is preferred by dabblers and migrating wood ducks. As decaying vegetation builds up in flooded areas, shovelers, pintails, and other diving species could forage on growing populations of plankton, algae, aquatic insects, and snails.

Over time, portions of properties adjacent to or near the mitigation site may be developed for commercial and/or residential uses. Depending on the nature of any development and its proximity to the mitigation site, some changes to the wildlife habitat functions provided by the mitigation site may occur. The 65-acre mitigation site is a large enough habitat area to provide key habitat functions for target wildlife species. The proximity of the mitigation site to riparian habitat corridors along the Green River will ensure that the project is connected to other terrestrial and aquatic habitats.

If significant areas of farmland near the mitigation site are developed, use of the mitigation area by non-water dependent wildlife (i.e., mammals such as deer, coyote, and red fox) may decrease because these species may be eliminated from adjacent areas. Development of nearby land with residential uses may increase use of the site by dogs and cats. Dogs and cats could affect some wildlife populations on the mitigation site (i.e., ground-nesting birds and small mammals could be subject to increased predation or cats could become a food resource for coyote). Depending on the exact proximity of development to the wetland buffer and the intensity of human use, wildlife use of the buffer could be reduced. Alternatively, wetland protection and restoration on nearby parcels that contain wetlands (likely required by existing regulations) could result in increased habitat for wildlife and enhanced wildlife function of the mitigation site.

Hydrology

Hydrologic conditions and functions at the wetland mitigation site are anticipated to be stable over the long term, even if future development occurs nearby. Hydrologic monitoring on the wetland mitigation site has been ongoing since September of 1995. The monitoring indicates that favorable sub-surface hydrology necessary for creating wetlands exists, and the probability of successful

wetland mitigation is high. Further, in planning the mitigation project, contingency actions have been identified that will be implemented if post construction monitoring indicates the required performance standards for the wetland are not achieved.

Monitoring results indicate that seasonally high groundwater levels on the site are maintained by precipitation. This conclusion is based on observations of rapid increases in groundwater during mid to late fall, often within several days of heavy rainfall. The rates of water level increase are more rapid than one would expect if the high water table were dependent on groundwater movement from off-site areas. Because the site hydrology is largely precipitation driven, off-site development that may occur near the mitigation would have minimal effect on the hydrology in the mitigation wetlands.

Finally, stormwater management (water quality and discharge) standards and/or wetland protection and restoration requirements for development on nearby parcels will protect the hydrology of the site. These standards are likely to prioritize infiltration, require water quality BMPs, and detention to prevent high flow discharges. Wetland protection requirements (required by existing regulations) could result in wetland restoration and further protect hydrologic conditions on the Port's mitigation site.

7.3 MITIGATION SITE DESIGN

The mitigation design is based on design objectives and criteria explained in this section. This section also explains the basis for specific design elements, including the rationale for establishing the wetland mitigation hydrologic water regime, grading plan, and planting plan.

The mitigation design for the wetland mitigation site consists of the following elements: (1) excavating two new wetland basins; (2) establishing native forested, shrub, emergent, and open-water wetland habitats in these basins; (3) enhancing the existing emergent wetlands by replacing the non-native plant communities with native forest and shrub communities; (4) establishing a forested buffer around the perimeter of the site; and (5) post-construction monitoring and maintenance.

7.3.1 Water Regime

An adequate water regime is the most critical factor in establishing the desired forest, shrub, and emergent wetland vegetation on the mitigation site. The duration and amount of standing water and soil saturation control the wetland classes and plant community types suitable for the site. Evaluation of the hydrology requirements of natural Puget Sound wetland communities (Ecology 1994a; Kunze 1994) and examination of over 5 years of groundwater monitoring data (see Figures 7.2-5, 7.2-6, and 7.2-7) indicate that it is feasible to create the hydrologic conditions necessary to sustain the diverse wetland habitats and plant communities designed for this site.

Appropriate hydrologic conditions will be attained by excavating the two basins on the mitigation site to intercept the seasonally high or permanent groundwater table. Excavating the new basins to approximately 1 to 8 ft below the current ground surface will provide a range of soil saturation conditions, and support the variety of planned wetland plant communities. Following grading, ground surface elevations on the site will range from approximately 37 to 50 ft, with most of the graded site below approximately 43 ft. Excavation in some limited areas will be a maximum of 12

ft deep to create open-water habitat. The approximate elevations, hydrologic regime, and wetland vegetation classes proposed for the mitigation are presented in Table 7.3-1. The relationship of the proposed wetland vegetation zones to anticipated water levels and site topography of the east basin is shown in Figure 7.3-1.

Table 7.3-1. Proposed wetland classes, elevation ranges, and hydrologic regimes.

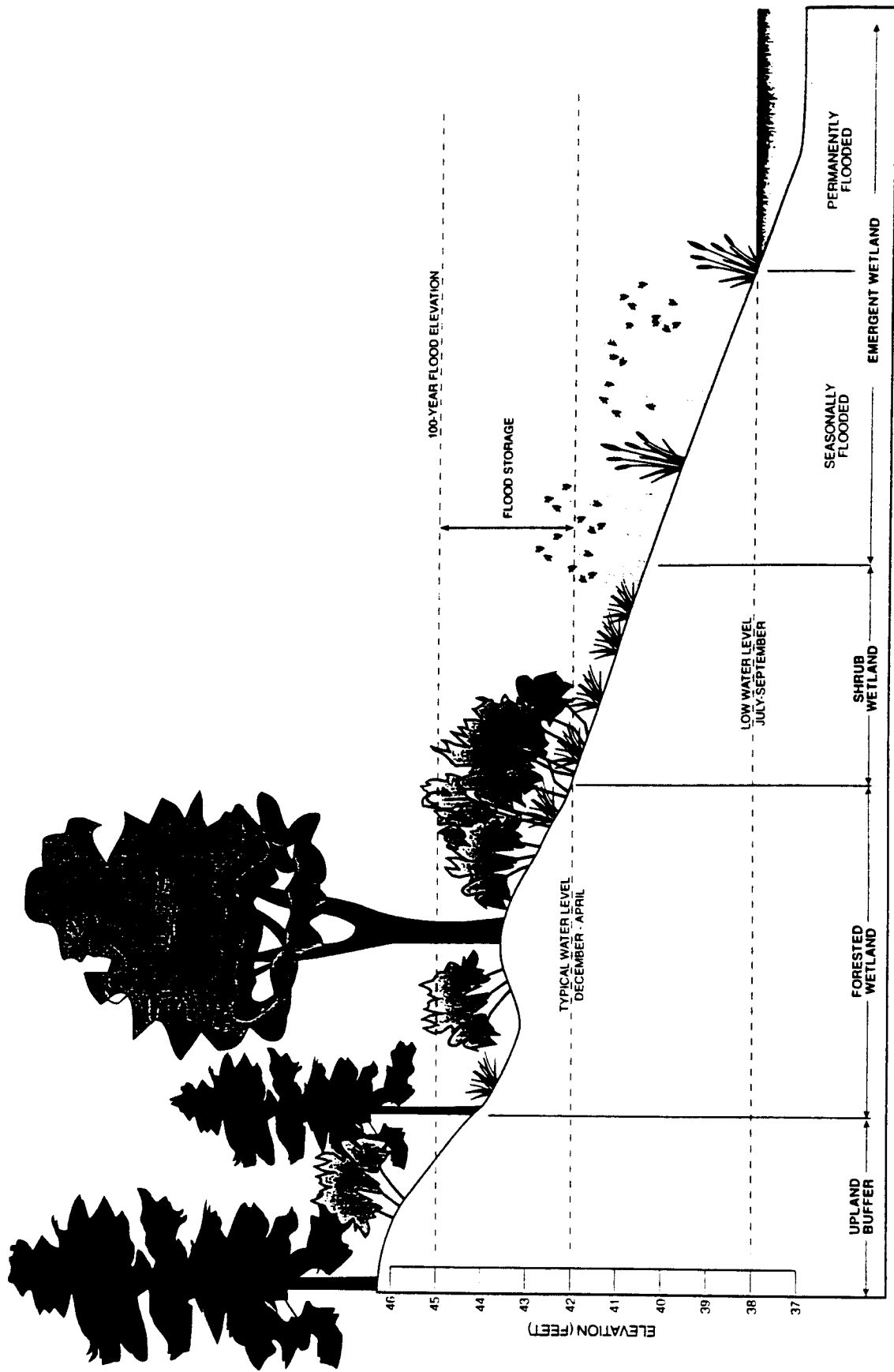
Proposed Wetland Class	Proposed Elevation Range (ft)	Anticipated Hydrologic Regime
Forested Wetland	East Basin: 42 to 46 West Basin: 46 to 49	Seasonally saturated soil during years of typical rainfall. During a 10-year flood, ¹ flooding of up to 3 ft for up to 9 consecutive days would occur. Soil would be unsaturated to at least 18 inches below the ground surface during most summer and fall periods.
Shrub Wetland	East Basin: 41 to 42 West Basin: 44 to 46	Seasonally saturated or flooded with up to 1 ft of water during years of average rainfall. During a 10-year flood, water could be up to 4 ft deep for 9 consecutive days. Soil would generally be saturated within 12 inches of the ground surface during most of the summer and early fall.
Persistent Emergent	East Basin: 38 to 41 West Basin: 42 to 44	Seasonally flooded with up to 4 ft of water during years of average rainfall. The water table would be at or within 6 inches of the ground surface during late summer and early fall.
Open-water/Unvegetated	East Basin: Below 38 West Basin: Below 42	Permanently to semi-permanently flooded during years of average rainfall. Surface water would generally be 6 to 24 inches deep during late summer and early fall, but may not be present during years of extremely low rainfall.

¹ Because of flood control management of the Green River, the peak flow for 10-year and 100-year flood events are equivalent.

The new wetland areas would be connected to the 100-year floodplain of Green River (see Figure 7.2-4) (FEMA 1989) by constructing a vegetated swale from existing ditches located along South 277th Street to the northwest corner of the wetland. The bottom elevation of this ditch would be at 41 ft. Existing and restored wetlands on the mitigation site would become inundated during 100-year flood events, as backwater flooding from the Green River reaches the site (see Figure 7.2-4).

During the 100-year flood event, water levels would increase in the wetland by up to 3 ft. The frequency of inundation due to Green River flooding is low (Figure 7.3-2), with the greatest probability occurring during late fall through mid-winter. All plants proposed for the wetland area are adapted to a fluctuating water table and periodic inundation, which is common during winter months in floodplain wetlands of western Washington. Therefore, vegetation "die-back" as a result of flooding should not occur.

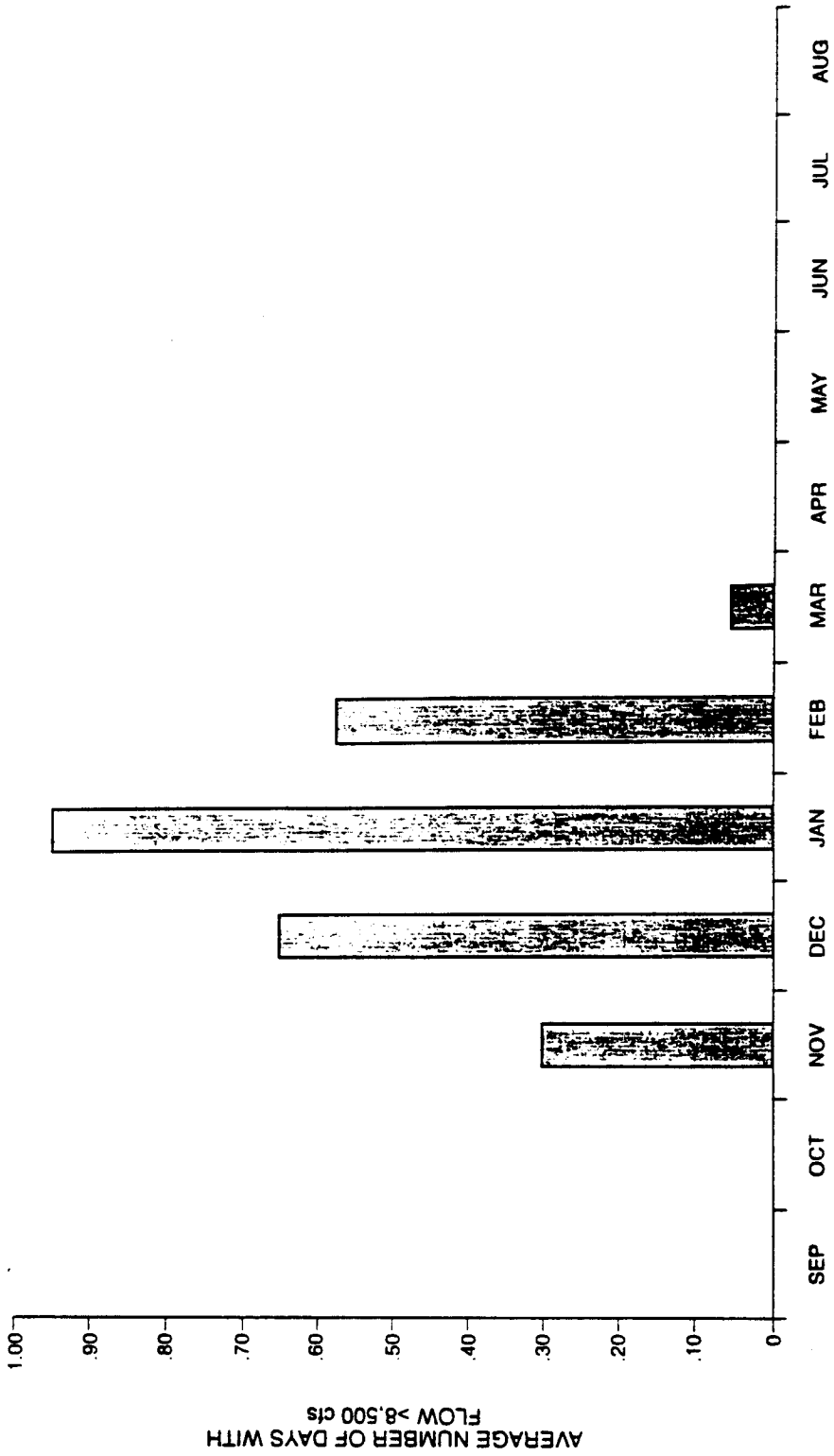
To provide additional flexibility in the control of site hydrology over the first few years of monitoring, a fixed-weir outlet control structure will be constructed near the northwest portion of the site to regulate water levels in the wetland. The weir can be adjusted by raising or lowering the gate and thereby raise or lower water levels. Such adjustments will allow flexibility in the control of site water levels over the first few seasons following planting. However, the weir will be permanently fixed once the desired level is determined (Appendix E, Sheets C3, C5, and C8).



Port of Seattle/Natural Resource Mitigation Plan/556-2912-001/03/12/00 (K)

Figure 7.3-1
Relationship of Seasonal Water Level
Variations and Soil Surface Elevations
to Proposed Wetland Vegetation Classes

Data Compiled by Parametrix



USGS 1996

Part of Seattle/Natural Resource Mitigation Plan 056-2912-001(03) 12/00 (K)

**Figure 7.3-2
Green River Flood Frequency by Month
(Based on 1960-1996 Data for Auburn)**

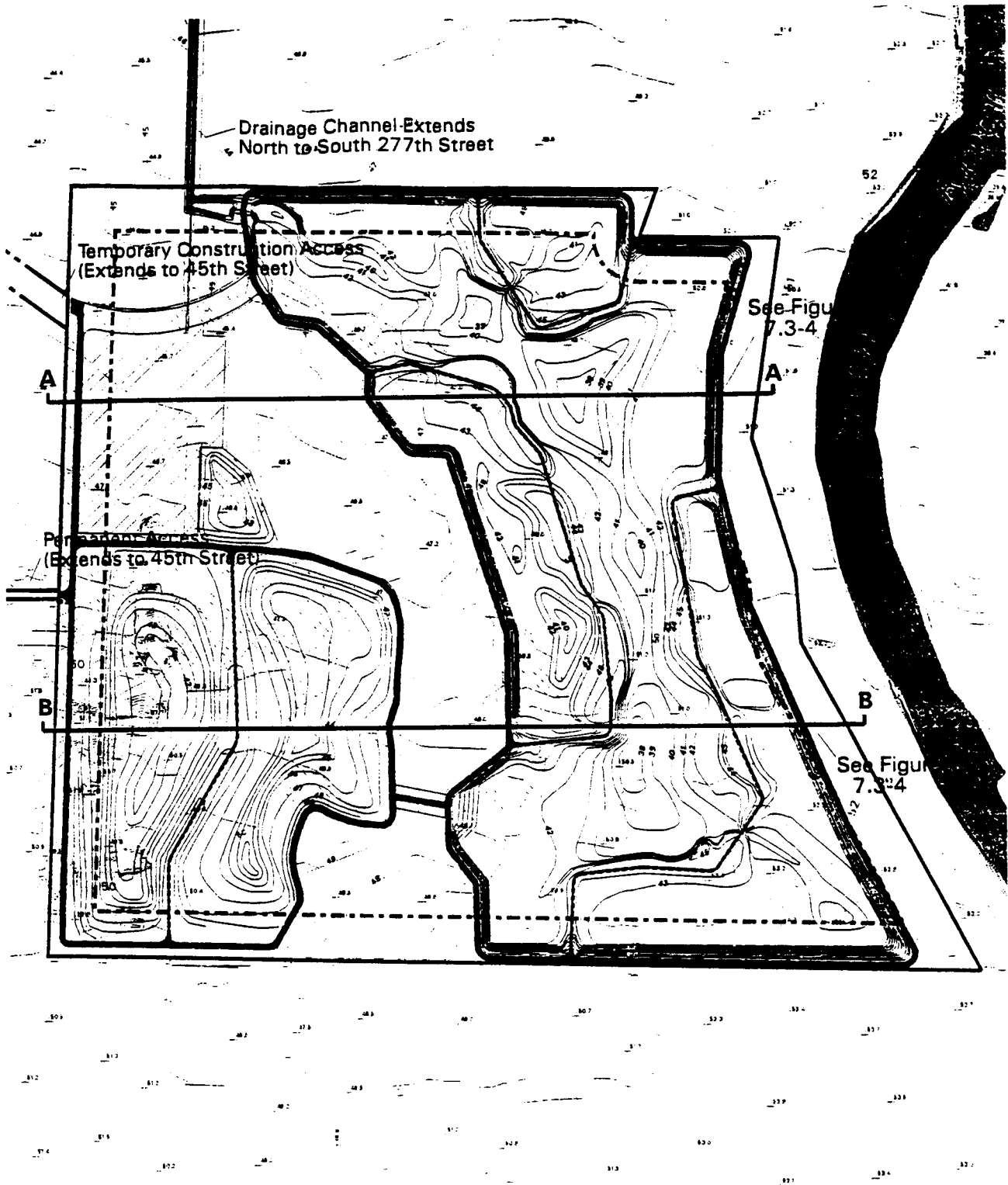
During the initial plant establishment phase, some control of water levels may be required to optimize establishment and survival of the planted stock. Any necessary adjustments to water regime are anticipated to be minor and short-term, and should not be necessary after plants become established. The Port will monitor site hydrology and plant survival carefully during the first few growing seasons and any adjustments to site water levels will be based on these monitoring results. Adjustments to the weir will be made by the Port's wetland scientist, and adjustments will be fully documented in monitoring reports. Following this initial plant establishment period, and based on any water level adjustments made during the first few years, the weir will be set at a fixed elevation appropriate for the site. No long-term adjustments to the weirs or site water levels are anticipated.

7.3.2 Grading

One basin will be excavated to the east, and another basin to the southwest of the existing wetlands to create two new wetland areas (Figures 7.3-3 and 7.3-4; Appendix E, Sheets C2 through C7). Excavation will generally be to depths between 1 and 5 ft below the existing ground surface to intercept the seasonally high or permanent groundwater table. Excavation depths will be slightly less in the western basin due to higher groundwater elevations, as well as to avoid impacts to the existing wetlands to the east of this basin. Due to site constraints, an area north of the west wetland creation basin will be used as a temporary staging area during construction. This area will be restored and enhanced after construction is complete (see Section 7.4-4).

Due to the high water table, the site will be dewatered prior to and during grading. Grading and site work other than planting will take place during the dry season (e.g., June through September). Site grading may take place in phases, if necessary, to ensure that all grading and site stabilization (e.g., hydroseed) can take place in one construction season. If construction of both basins cannot be completed in the same season (i.e., excavation, final grading, site stabilization), then the east basin will be constructed first and the west basin the following year. Construction is currently anticipated to begin during the 2001 dry season. Major construction activities will be limited to the period from October 31 to March 31 to avoid any disturbance to wintering bald eagles that may be in the vicinity of the Green River.

The proposed grading would affect about 11.9 acres of the existing emergent wetland described in Section 7.2.5.1 (see Table 3.1-4). In addition, a maximum of 2.2 acres of low quality emergent wetland and existing wetland drainage ditches (located north of the site) will be widened to connect with the 100-year floodplain and existing ditch systems, which will provide floodwater storage and conveyance functions. Approximately 0.12 acre of existing wetland will be permanently impacted by access roads. However, no net loss of wetland area will result due to the restoration and wetland creation actions planned for the site.



Prepared by Parametrix, Inc. File: seaboc1/8x11/uburn_grade.aml creating p&w11/uburn_grade.pw Date: December 18, 2000

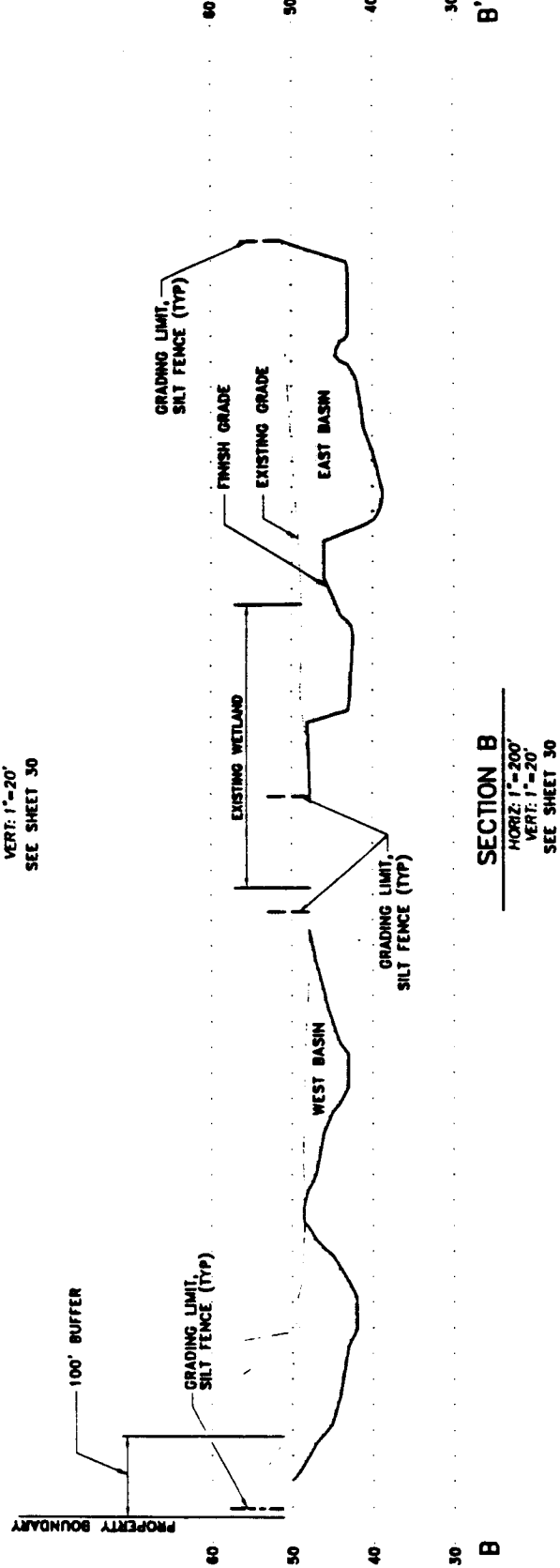
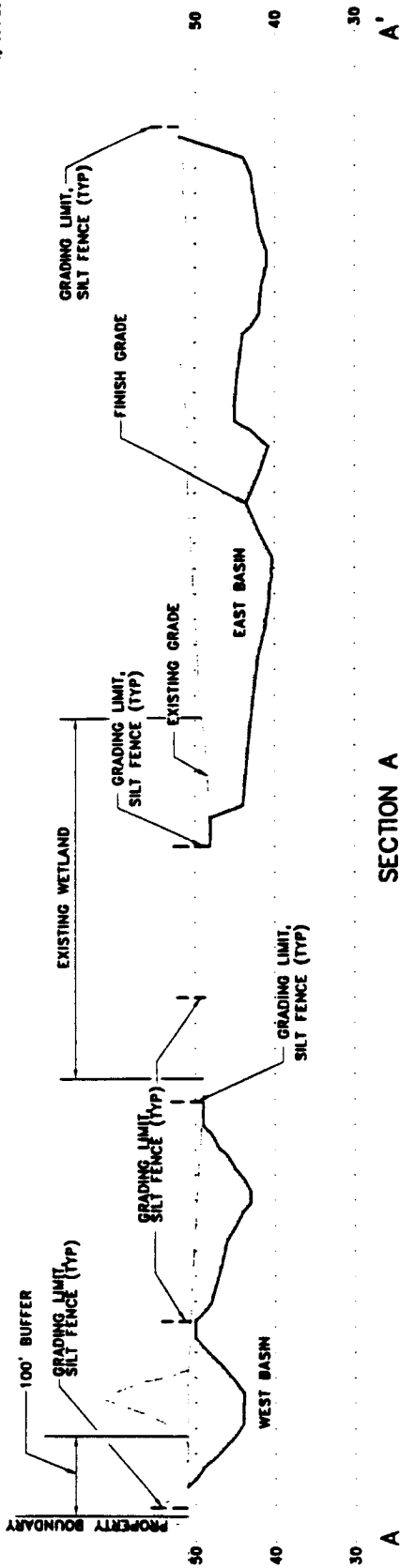


Scale 1:3500

- | | | | |
|---|---|---|-------------------|
| — | Jurisdictional Wetlands | — | Maintenance Roads |
| — | Temporary Staging Area (enhanced following construction) | — | Gravel Roads |
| — | Wetlands modified to construct mitigation. (See Tabl 3.1-4) | — | Proposed Grade |
| — | | — | Property Boundary |
| — | | — | 100 Foot Buffer |
| — | | — | Easement |
| — | | — | Existing Contours |

**Figure 7.3-3
Wetland Mitigation
Grading Plan**

AR 048893



FILE: 791703_031
 DATE: 10/17/00

Figure 7.3-4
 Grading Cross Section for
 Off-site Wetland Mitigation

Maintenance roads will be constructed around each wetland basin to provide access to the site during planting, maintenance, and monitoring. These roads will be removed and these areas will be restored and enhanced with native vegetation after construction is complete.

7.3.2.1 Surface Soil Removal

The first grading step will be to strip off the top 12 inches of soil, which will be disposed of in an approved, upland location off site. Removal of this soil will remove rhizomes, roots, and seeds of the existing vegetation, and minimize re-colonization by non-native plants after native plants are installed. Suitable subsoil material removed during excavation will be stockpiled, amended with composted organic material that is free of weeds, spread to a depth of 12 inches, and disced into the subsoil prior to installing plants. Approximately one-third of the excavated soil will be stockpiled for use as topsoil in the new basins. Soils that become compacted during grading will be ripped and/or disced to break up the soil and provide a suitable rooting medium for plants.

7.3.2.2 Basin Excavation and Dewatering

Approximately 440,000 cy of soil will be excavated to create the two wetland basins, with excavation depths ranging between 1 and 8 ft. Due to seasonally high groundwater levels on this site, dewatering will likely be necessary to allow excavation of the new wetland basins and site grading. Water from the site dewatering will be conveyed through a series of sediment/settling ponds and straw bale filters to existing ditches that drain the site at the northwest corner.

Dewatering Plan

All dewatering will be performed according to conditions of the HPA obtained for the project. The Port estimates that the current groundwater table should be lowered approximately 5 ft below the subgrade to facilitate grading. The dewatering plan would use approximately 45 to 50 wells that extend into the shallow groundwater table. To lower the water table sufficiently to allow grading, water will be pumped off-site via these wells. Groundwater will be conveyed to the existing ditch that drains the site. It is estimated that dewatering on the project site could discharge up to 4,600 gallons per minute of groundwater while the excavation is occurring. The highest discharge rates are anticipated to occur early in the construction season (May or June) with little discharge occurring in August or September.

Two retention ponds will be constructed to capture runoff from the Phase 1 construction staging area located on the northwest portion of the site. Based on the design criteria and runoff modeling, the minimum total storage volume required is 3.65 acre-feet. This volume will contain the 25-year summer storm event, with a 1.5 factor of safety. A smaller pond, able to retain at least 0.77 acre-feet of runoff, will serve the northern section of the staging area. A larger pond, with a minimum storage capacity of 3.65 acre-feet, will collect runoff from the remaining portion of the site as well as the pumped discharge from the smaller pond.

Sediment in the pond water will be removed by an on-site alum treatment facility. The treatment facility will consist of three coagulation tanks and one settling tank. Additional coagulation tanks will be utilized, if necessary. While treated water from the facility will be discharged off-site; any treatment plant bypass water will be discharged on-site. In addition, sediment from the facility will

be redeposited on-site. Surface water that accumulates during the excavation will also be treated prior to being discharged from the site. All water discharged from the site must meet turbidity standards for water quality. These standards are less than 5 NTUs above background when background levels are less than 50 NTUs, and no more than 10 percent above background when background levels are more than 50 NTUs.

Drainage Easements for Dewatering

The Port has procured a temporary drainage and construction easement across the property north of the mitigation site that allows use of an existing channel for drainage purposes. The easement also grants the Port the right to use this channel for the temporary discharge of water from dewatering wells to be used during construction of the Port's wetlands. During the dewatering process, water will be temporarily channeled to the existing outfall into the Green River at South 277th Street. Other than during the dewatering process, drainage water from the Port's property will flow north through existing drainage channels along and under South 277th Street, and discharge to the Green River north of South 277th Street. The newly constructed wetland basins will generally drain to the northwest at elevations of 42 ft in the east and 43 ft in the west. The temporary drainage and construction easement remains in effect until a permanent flood channel is constructed.

The location of the temporary drainage channel is shown on Appendix E, Sheet C3. A cross-section schematic of the temporary drainage channel (i.e., wetland outlet ditch) is shown on Appendix E, Sheet C8.

Effects of Dewatering on Existing Wetlands

Dewatering activities on the Auburn site are not likely to affect the hydrology or habitat conditions in existing wetlands located on or near the mitigation site. Dewatering of the site will occur from approximately May through September, over one or two seasons. The purpose of dewatering is to accelerate the rate at which the water table falls during the summer and early fall. During this time, the water table in the wetlands normally falls a total of 6 to 8 ft over a period of 4 to 5 months (see Figures 7.2-5, 7.2-6, 7.2-7). In May, at the time dewatering starts, the water level in the wetlands is typically 24 inches below the ground surface, and thus below the rooting zone of wetland plants. By late May it is as much as 36 inches below the surface. Because the timing of dewatering is such that it will occur after water levels in the wetlands have already dropped below the surface root zone, wetland vegetation will not be impacted by dewatering. Dewatering will not lower the water table below the elevation it normally reaches by late summer, and thus, dewatering will not increase the amount of time it takes the water table to rise again in the fall. Since it is not present, dewatering will not remove surface water that could provide special habitat types to wildlife.

7.3.2.3 Topsoil Replacement and Finish Grading

Native subsoils at the Auburn site are a mix of silts and fine sands, and will be used to construct an amended topsoil for the site. Approximately one-third of the excavated material will be selectively stockpiled either at on-site staging areas, or off site, for use as backfill and to construct topsoil for the excavated areas.

Two types of soil amendments will be used to provide a suitable substrate for wetland plant establishment on the site. The first soil type (Wetland Soil 1) will be a 3:1 mix of suitable native

Two types of soil amendments will be used to provide a suitable substrate for wetland plant establishment on the site. The first soil type (Wetland Soil 1) will be a 3:1 mix of suitable native subsoils with organic compost that is free of weed seeds or other unsuitable material. This soil will be used above 42 ft elevation in the east basin and throughout the excavated area of the west basin (Appendix E, Sheet C9). The second soil type (Wetland Soil 2) will be used below 42 ft in elevation in the east basin to provide soil for the emergent planting zone (Appendix E, Sheet C9). Native subsoils on the site are a mix of sands, silts, and clays, and naturally form layers that are relatively impervious. To ensure that subsoils used in the emergent planting zones maintain this relative impermeability, Wetland Soil 2 will be native subsoil amended with 4 percent bentonite.

Final grades will establish elevation and hydrologic gradients, which will allow the planting of the desired native plant community types (see Figure 7.3-4). Fine grading and habitat log placement will also establish a complex microtopography on the site, which will enhance water storage and microhabitat diversity (Appendix E, Sheet 8.2). Habitat log placement and installation of snags will enhance wildlife functions on the site. Placement of logs, snags, and fine grading will be accomplished under field direction by the landscape architect and/or wetland scientist. Microtopography will be established by constructing a series of 'pit and mound' features in the forested and shrub wetland areas. Pit and mound features are designed to simulate the microtopography created by windthrow of large trees. Pit and mound features will be constructed at a density of approximately 4 per acre. Habitat logs will be placed predominantly in forested and shrub wetland classes, with a density of approximately 15 per acre (Appendix E, Sheet C9).

7.3.2.4 Hydroseed/Mulch

Following completion of fine grading and topsoil placement, the soil surface will be stabilized with a hydroseed/mulch mix consistent with federal and state permit conditions and the City of Auburn grading permit.

Hydroseed mixes have been designed to accomplish several objectives. Hydroseeding is part of the TESC measures and will provide short-term stabilization of the soil surface and erosion control following grading. Hydroseeding will also provide for the rapid establishment of ground cover and serve as a weed barrier to reduce colonization of the open site by invasive species. In addition, native herbaceous understory species for the forest, shrub, and emergent communities will be provided by hydroseeding prior to planting the overstory vegetation in these zones.

Hydroseeding will use one of three seed mixes, with the mix selected for each zone matched to the site moisture conditions in that zone (Table 7.3-2). A wet zone seed mix consisting of OBL and FACW species will be used below 43 ft in the east basin and below 46 ft in the west basin (see Figure 7.3-4). A transition zone seed mix consisting of FACW, FAC+, and FAC rated species will be used from 43 to 45 ft in the east basin and from 46 to 49 ft in the west basin. A native buffer seed mix consisting of FAC, FAC+, FAC-, and FACU rated species will be used in the forested buffer areas above 45 ft in the east basin and above 49 ft in the west basin. In addition, a low-grow seed mix will be used to revegetate temporary construction access roads and staging areas that are located outside the mitigation area.

Table 7.3-2. Hydroseed mixtures.

Common name	Scientific Name	% by weight
For use in areas designated as emergent wetland		
Tall mannagrass	<i>Glyceria elata</i>	15
Water foxtail	<i>Alopecurus geniculatus</i>	10
Water parsley	<i>Oenanthe sarmentosa</i>	10
Slough sedge	<i>Carex obnupta</i>	10
Beaked sedge	<i>Carex rostrata</i>	15
Small-fruited bulrush	<i>Scirpus microcarpus</i>	15
Woolgrass	<i>Scirpus cyperinus</i>	10
Dagger leaf rush	<i>Juncus ensifolius</i>	5
Taper tip rush	<i>Juncus acuminatus</i>	5
Slough grass	<i>Beckmannia syzigachne</i>	5
For use in areas designated as forested or shrub wetland and wet buffers		
Blue wildrye	<i>Elymus glaucus</i>	25
Western mannagrass	<i>Glyceria occidentalis</i>	8
Tall mannagrass	<i>Glyceria elata</i>	10
Tufted hairgrass	<i>Deschampsia cespitosa</i>	10
Annual ryegrass	<i>Lolium multiflorum</i>	15
Chewings red fescue	<i>Festuca rubra</i>	10
Meadow foxtail	<i>Alopecurus pratensis</i>	10
Bentgrass	<i>Agrostis tenuis</i>	10
Alsike clover	<i>Trifolium hybridum</i>	2
For use in upland buffer areas		
Barkley's perennial ryegrass	<i>Lolium perenne</i>	30
Red fescue	<i>Festuca rubra</i>	35
Aurora hard fescue	<i>Festuca longifolia</i>	35

Hydroseed mixes will be comprised predominantly of native grass, sedge and rush species. However, some non-native grasses may be included to provide rapid germination and growth for erosion and weed control. Use of non-natives will be restricted to species that are not invasive, and will not persist once the planted stock becomes established and canopies become closed. The buffer zone hydroseed mix is designed to establish a low-growing ground cover of grasses that will protect the soil, and reduce erosion while minimizing competition with the planted stock. The wetland and transition seed mixes are designed to supplement the container stock by increasing ground cover and plant density.

7.3.2.5 Temporary Irrigation

An irrigation system will be installed on the mitigation site (Appendix E, Sheets L1 through L3). Irrigation with municipal water purchased by the Port will be used during the initial stages of the restoration to optimize conditions for plant establishment. Irrigation will be used to provide

flexibility in the timing of plant installation, to increase survival rates, and to enhance growth rates of the planted stock. Enhancing plant growth during the first few years will lead to a more rapid establishment of canopy cover and shade on the site, and reduce re-invasion of the site by non-natives.

The irrigation system will be installed, tested, and fully operational before plants are installed. Irrigation in the existing wetland will be installed above ground to minimize disturbance during installation. Irrigation in the areas to be excavated and graded will be installed below ground.

The irrigation system will be sufficiently durable to provide irrigation to the site throughout the monitoring period; however, it is likely that the system will be used longer than the first few growing seasons. Irrigation will be used for the first few years following planting. In subsequent years, the Port will evaluate the need for continued irrigation based on need for replanting, observed plant survival, and other factors. Once the system is no longer needed, the above-ground portions (e.g., risers, sprinkler heads, valves, or control boxes) will be removed. The below-ground portions of the system will be abandoned in place to minimize disturbance to the created and enhanced wetlands.

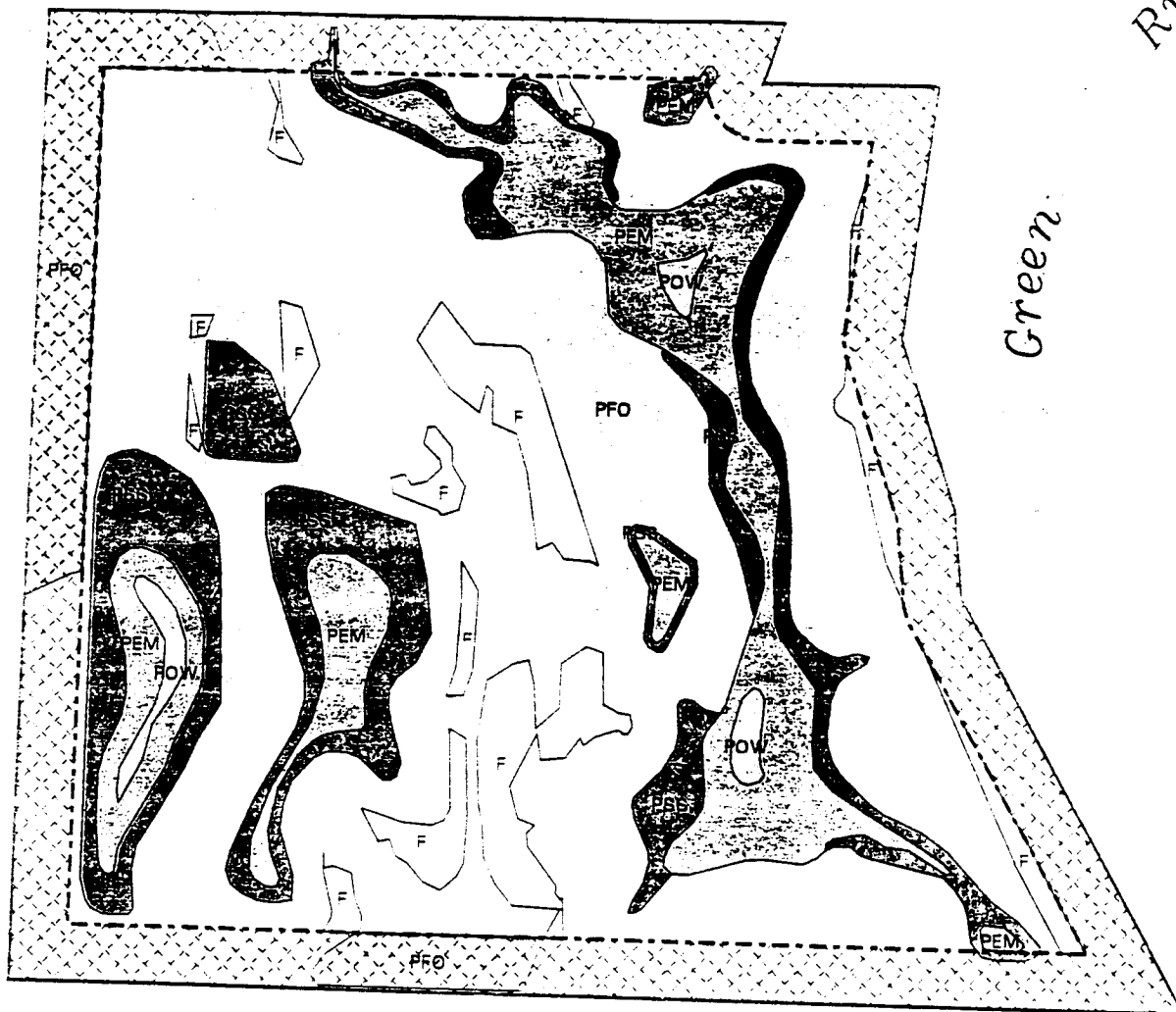
7.3.3 Landscape Plan

Native species will be planted to establish forested wetland, shrub wetland, and emergent wetland plant communities, as well as a forested upland buffer around the edges of the site (Figure 7.3-5; Appendix E, Sheets L5 through L10). These general community types would include six wetland plant associations (or planting zones) typical of freshwater wetlands and forested uplands in the northern Puget Sound basin (Figure 7.3-6). Choice of plant species, planting densities, and community composition is based primarily on composition and densities of common western Washington wetland plant communities (Kunze 1994). In addition, plant species were chosen for their value as food sources or habitat elements for wildlife. For example, the design includes shrubs and emergent plants that are particularly valuable as wildlife food sources (e.g., hazelnut, Indian plum, sedges, and bulrushes).

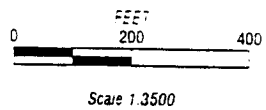
Forested wetland plant communities include black cottonwood/Pacific willow, red alder/salmonberry, Oregon ash/Pacific willow, and western redcedar plant communities. A dogwood/willow shrub community and a beaked sedge/water parsley emergent community will be planted in wetter portions of the site, surrounding small areas of open water in the centers of the basins. The existing emergent wetland will be enhanced by planting black cottonwood, Oregon ash, and red alder forested communities to increase plant diversity and enhance wildlife habitat (Appendix E, Sheets L5 through L10). The upland buffer will be planted with a mix of native trees and shrubs such as Douglas fir, big-leaf maple, vine maple, hawthorn, and Indian plum (Appendix E, Sheet L10). Along the boundaries of the site, the upland buffers will be planted densely adjacent to the perimeter fence with species likely to discourage intrusion into the site (e.g., tall Oregon grape, hawthorn, rose). Planting may occur in phases, with an initial planting of rapidly growing plants tolerant of full sun followed by a second planting of species that are more shade tolerant.

River

Green



Prepared by Parametrix, Inc. File: seatac28x11a\output_classes.amr\creating\pdx11a\output_classes.pra Date: December 18, 2002



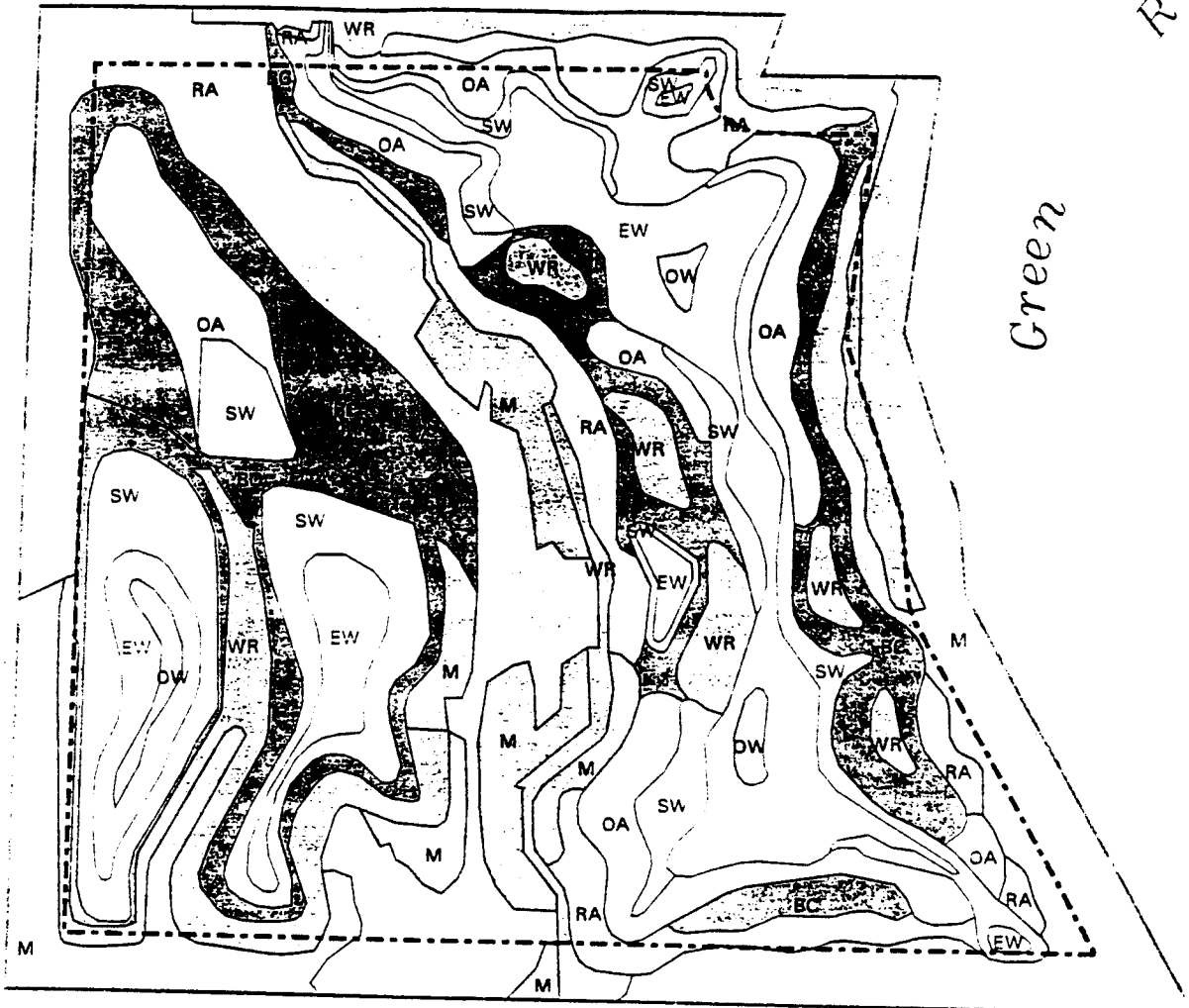
- | | | | |
|--|----------------------------|--|---------------------|
| | (PFO) Paustine Forested | | (F) Forested Upland |
| | (PSS) Paustine Scrub-Scrub | | Forested Buffer |
| | (PEM) Paustine Emergent | | Property Boundary |
| | (POW) Paustine Open Water | | 100 Foot Buffer |

**Figure 7.3-5
Wetland Vegetation
Classes for the
Wetland Mitigation
Site**

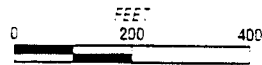
AR 048900

River

Green



Prepared by Parametrix, Inc. File: seatac2/bx11auburn_plants.amx/creating/bx11auburn_plants.gra Date: December 18, 2000



Scale 1:3500

- | | | |
|-----------------------|-----------------------|-------------------------------|
| Black Cottonwood (BC) | Mixed Forest (M) | Emergent Wetland (EW) |
| Red Alder (RA) | Western Redcedar (WR) | Open Water Non-vegetated (OW) |
| Oregon Ash (OA) | Shrub Wetland (SW) | Property Boundary |
| | | 100 Foot Buffer |

**Figure 7.3-6
Plant Associations
for the Wetland
Mitigation Site**

AR 048901

The sections below describe the general planting approach for each planting zone. The sections identify the types of plant species, the condition of material planted (container, bareroot, live stakes, seed, or plugs), and the planting approach (density, pattern, and area of coverage). At the time of planting, minor variations in the plantings may occur to account for site-specific factors and the planting season. For example, if an area is planted in late spring or summer, container-grown versus live-stake material would be used. Similarly, during late fall, winter, or early spring plantings, a greater amount of bareroot and live-stake versus container-grown material would be planted. Figure 7.2-14 depicts the expected growth pattern of the plantings as time progresses. It is anticipated that a mature forested wetland system will develop within 50 years.

Plant material used in the mitigation will be obtained from commercial nurseries. Nurseries will be required to certify that the plant material is legally procured and from the appropriate geographic sources. The appropriate geographic sources for plant material used in the mitigation is the area that is bounded on the north by the Fraser River Valley of British Columbia, on the east by the 1,000-foot elevation of the Cascades, on the west by the 1,000-foot elevation in the Olympic or Coast ranges, and on the south by the Willamette Valley.

7.3.3.1 Weed Control

Invasive non-native species such as reed canarygrass and Himalayan blackberry can reduce successful establishment of desirable native plant species. A variety of weed control strategies are available to treat non-native species prior to and during the native plant installation period. These control strategies are incorporated into the planting design, or will be implemented during the monitoring period to control invasive species. Weed control methods are:

- Dense plantings of target species that competitively exclude non-native species
- Applications of EPA-approved herbicides by licensed applicators
- Application of sterile straw or other biodegradable mulch as a weed barrier
- Installation of biodegradable weed barrier fabric
- Mechanical removal using mowers or line trimmers, or hand removal

Several methods for controlling reed canarygrass are currently proposed. An integrated approach, relying on a suite of control strategies (listed above) and adaptive management will be used to control reed canarygrass at the Auburn site.

Topsoil containing weed seed, roots, and rhizomes will be removed in order to establish appropriate wetland hydrology over much of this site. Existing vegetation, including reed canarygrass, may also be removed from the site by application of approved herbicides, plowing, cultivating, and allowing the site to lie fallow. The project has been designed to anticipate some colonization of reed canarygrass by targeting the establishment of forested wetlands that ultimately will shade out the reed canarygrass. Competitive exclusion will be used early in the planting period by seeding areas with a fast-germinating cover crop (see Table 7.3-2). Competitive grass species such as tufted hairgrass (*Deschampsia cespitosa*), sloughgrass (*Beckmannia syzigachne*), bentgrass, or red fescue can be effective in establishing cover and reducing invasion by reed canarygrass. Contingency actions could include repeated applications of herbicides, mowing, or use of weed barriers.

7.3.3.2 Plant Protection from Animals

To deter plant damage by rodents (i.e. herbivory), plants may be installed with protective devices such as plastic stem collars. Depending on the type of community and level of herbivory, deterrence measures may range from plastic collars around individual stems to wire mesh around groups of plants. After plants are installed, a 4- to 6-inch-deep covering of mulch will be placed in a 6-ft radius around the base of each plant to conserve water, provide organic material, and serve as a weed barrier.

7.3.3.3 Perimeter Fencing

A fence will be installed around the perimeter of the site to clearly mark the mitigation boundary and to protect the mitigation site from intrusion and damage from people or domestic animals. Based on discussions with ACOE, the Port has designed a fence that will be post and rail or equivalent. In addition to the fence, signs will be posted along the boundary of the mitigation site, designating the site as a wetland mitigation area.

7.3.4 Native Plant Communities

The planting plan will result in establishing five forested communities, one shrub community, and one emergent community on the site. Four of the forested communities, as well as the shrub and emergent communities, are wetlands. An upland forested community will be planted in buffer zones.

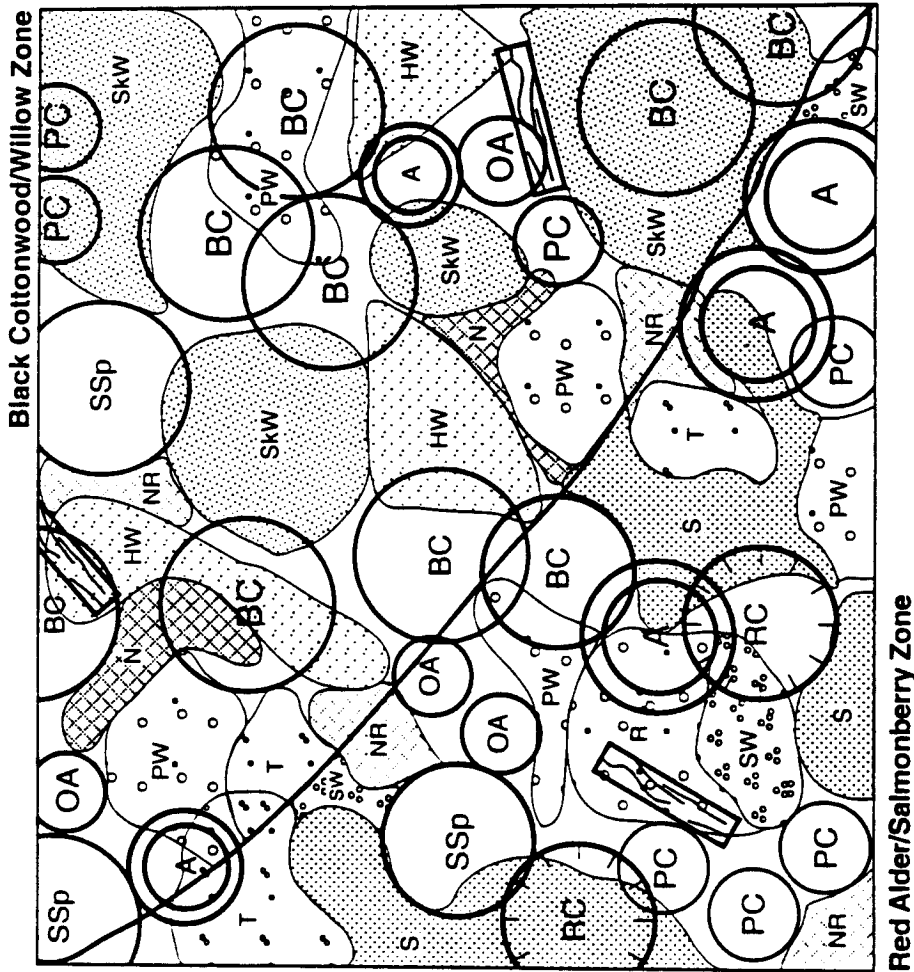
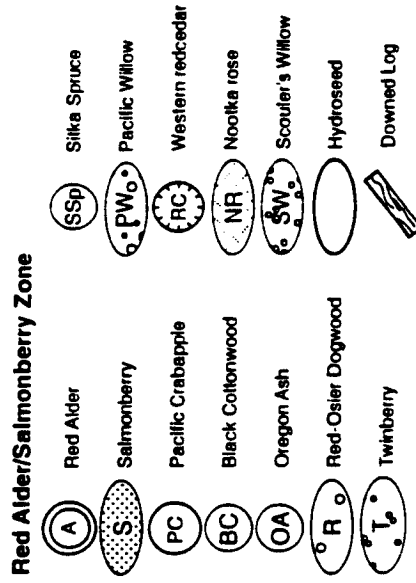
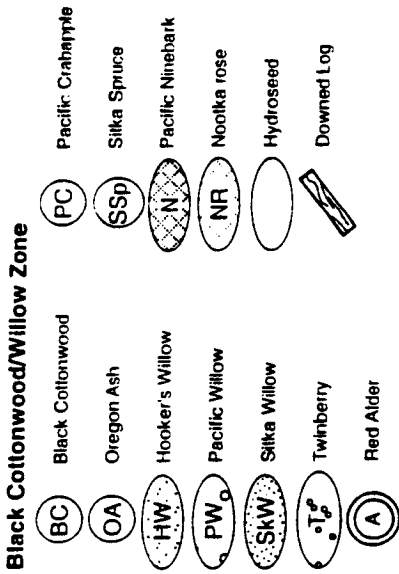
7.3.4.1 Forested Communities

Black Cottonwood/Willow Association

The black cottonwood/willow association is characteristic of many floodplain forested wetlands in western Washington, including the Green River Valley. The plants within this association (Table 7.3-3 and Figure 7.3-7) are adapted to large fluctuations in the water table and are tolerant of seasonally dry soils. This zone would be planted above elevation 42 ft on the east side and above elevation 46 ft on the west side.

Red Alder/Salmonberry Association

The red alder/salmonberry association (Table 7.3-4, see Figure 7.3-7) commonly occurs on wet valley floors in seasonally flooded areas (Kunze 1994). This association would be planted above the 42-ft elevation on the east side and above the 46-ft elevation on the west side, where year-round soil saturation would not occur.



Note: See Appendix E Sheets L5 · L10 for more details

Figure 7.3-7
Typical Planting Plan Example
for the Black Cottonwood and
Red Alder Planting Zones



Port of Seattle/Natural Resource Mitigation Plan 556-2912-001/01/03/1200 (K)

Table 7.3-3. Proposed plant species for the black cottonwood/willow association.

Scientific Name	Common Name	Indicator Status ¹	Condition
Trees			
<i>Alnus rubra</i>	Red alder	FAC	container
<i>Fraxinus latifolia</i>	Oregon ash	FACW	container
<i>Malus fusca</i>	Pacific crabapple	FACW	container
<i>Picea sitchensis</i>	Sitka spruce	FAC	container/bareroot
<i>Populus trichocarpa</i>	Black cottonwood	FAC	container/ live stake
<i>Salix lasiandra</i>	Pacific willow	FACW+	container/ live stake
Shrubs			
<i>Lonicera involucrata</i>	Twinberry	FAC+	container
<i>Physocarpus capitatus</i>	Pacific ninebark	FACW-	container
<i>Rosa nutkana</i>	Nootka rose	FAC	container
<i>Salix hookeriana</i>	Hooker's willow	FACW	container/ live stake
<i>Salix sitchensis</i>	Sitka willow	FACW	container/ live stake

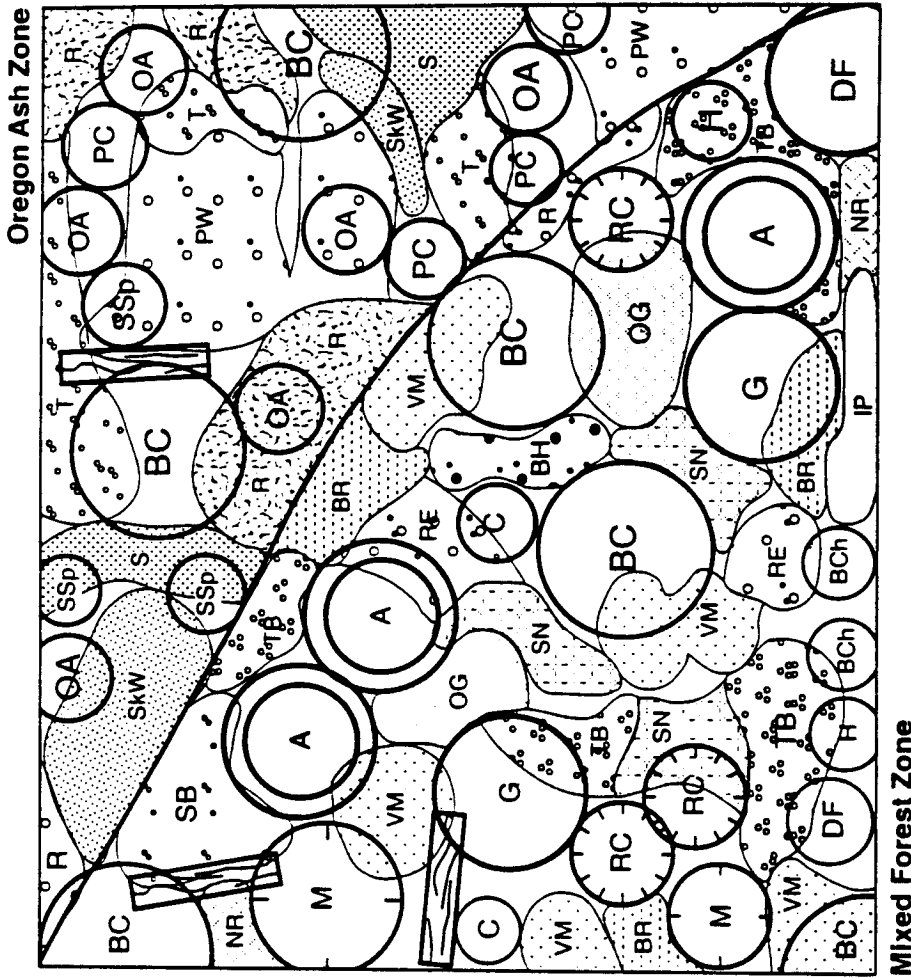
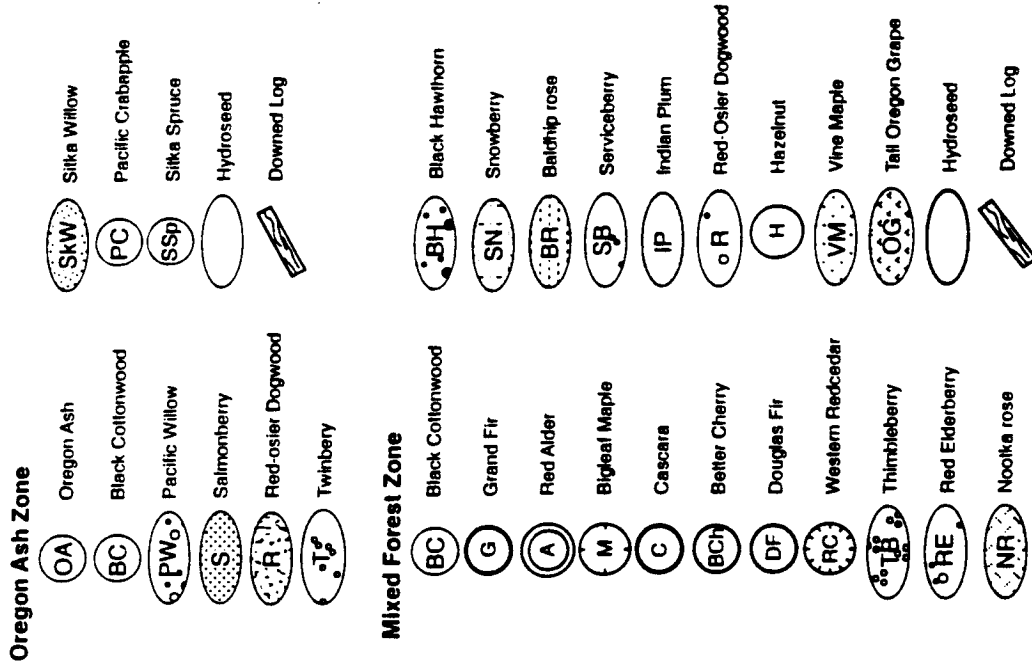
¹ See Table 7.2-4 for indicator status definitions

Table 7.3-4. Proposed plant species list for the red alder/salmonberry association.

Scientific Name	Common Name	Indicator Status	Condition
Trees			
<i>Alnus rubra</i>	Red alder	FAC	container
<i>Fraxinus latifolia</i>	Oregon ash	FACW	container
<i>Malus fusca</i>	Western crabapple	FACW	container
<i>Picea sitchensis</i>	Sitka spruce	FAC	container
<i>Populus trichocarpa</i>	Black cottonwood	FAC	container/live stake
<i>Salix lasiandra</i>	Pacific willow	FACW+	container/live stake
<i>Thuja plicata</i>	Western redcedar	FAC	container/ bareroot
Shrubs			
<i>Cornus stolonifera</i>	Red-osier dogwood	FACW	container/ live stake
<i>Lonicera involucrata</i>	Twinberry	FAC+	container
<i>Rosa nutkana</i>	Nootka rose	FAC	container
<i>Rubus spectabilis</i>	Salmonberry	FAC+	container
<i>Salix scouleriana</i>	Scouler's willow	FAC	container/ live stake

Oregon Ash Association

The Oregon ash association is most commonly found in floodplains or associated with streams and backwater sloughs (Kunze 1994). This community would be planted in the wetter portions of the forest zone, since most of the associated species are tolerant of soil saturation and inundation well into the spring. Oregon ash will comprise most of the canopy cover, with salmonberry and willow in the shrub layer (Table 7.3-5; Figure 7.3-8).



Note: See Appendix E Sheets L5 - L10 for more details

Figure 7.3-8
Typical Planting Plan
for the Oregon Ash and the
Mixed Forest Planting Zone



Port of Seattle/Natural Resource Mitigation Plan 556-2912-001/01(03) 12/00 (K)

Table 7.3-5. Proposed plant species list for the Oregon ash association.

Scientific Name	Common Name	Indicator Status	Condition
Trees			
<i>Fraxinus latifolia</i>	Oregon ash	FACW	container
<i>Malus fusca</i>	Western crabapple	FACW	container
<i>Picea sitchensis</i>	Sitka spruce	FAC	container/bare root
<i>Populus trichocarpa</i>	Black cottonwood	FAC	container/ live stake
<i>Salix lasiandra</i>	Pacific willow	FACW+	container/ live stake
Shrubs			
<i>Cornus stolonifera</i>	Red osier dogwood	FACW	container/live stake
<i>Lonicera involucrata</i>	Twinberry	FAC+	container
<i>Rubus spectabilis</i>	Salmonberry	FAC+	container
<i>Salix stichensis</i>	Sitka willow	FACW	container/live stake

Mixed Forest Association

The mixed forest association includes several coniferous and deciduous tree species as well as an understory shrub component. Some of the tree species in this association are not tolerant of prolonged saturation. Therefore, this association would be planted in the upper zone between wetland and upland, as well as in the upland buffers (Table 7.3-6; see Figure 7.3-8).

Table 7.3-6. Proposed plant species list for the mixed forest association.

Scientific Name	Common Name	Indicator Status	Condition
Trees			
<i>Abies grandis</i>	Grand fir	FACU-	container
<i>Acer macrophyllum</i>	Big-leaf maple	FACU	container
<i>Alnus rubra</i>	Red alder	FAC	container
<i>Crataegus douglasii</i>	Black hawthorn	FAC	container
<i>Populus trichocarpa</i>	Black cottonwood	FAC	container/ bare root
<i>Prunus emarginata</i>	Bitter cherry	FACU	Container
<i>Psuedotsuga menziesii</i>	Douglas fir	FACU	container
<i>Rhamnus purshiana</i>	Cascara	FAC-	container
<i>Thuja plicata</i>	Western redcedar	FAC	container
Shrubs			
<i>Acer circinatum</i>	Vine maple	FAC-	container
<i>Amelanchier alnifolia</i>	Serviceberry	FACU	container
<i>Berberis aquilifolium</i>	Tall Oregon grape	FACU	container
<i>Corylus cornuta</i>	Hazelnut	FACU	container
<i>Oemleria cerasiformis</i>	Indian plum	FACU	container
<i>Rosa gymnocarpa</i>	Bald-hip rose	FACU	container
<i>Rosa nutkana</i>	Nootka rose	FAC	container
<i>Rubus parviflorus</i>	Thimbleberry	FAC-	container
<i>Sambucus racemosa</i>	Red elderberry	FACU	container
<i>Symphoricarpos albus</i>	Snowberry	FACU	container

Western Redcedar Association

The western redcedar association includes deciduous as well as coniferous tree species, with an understory of FAC and FACW shrub species (Table 7.3-7; Figure 7.3-9). Tree species such as western redcedar and big-leaf maple are not tolerant of prolonged soil saturation. Therefore, this association will be planted in the upper portions of the wetland zone, or above approximately 47 ft in the west and about 44 ft in the eastern basin.

Table 7.3-7. Proposed plant species list for the western redcedar association.

Scientific Name	Common Name	Indicator Status	Condition
Trees			
<i>Abies grandis</i>	Grand fir	FACU-	container/ bareroot
<i>Acer macrophyllum</i>	Big-leaf maple	FACU	container
<i>Alnus rubra</i>	Red alder	FAC	container
<i>Populus trichocarpa</i>	Black cottonwood	FAC	container/ bareroot
<i>Rhamnus purshiana</i>	Cascara	FAC-	container
<i>Thuja plicata</i>	Western redcedar	FAC	container
Shrubs			
<i>Acer circinatum</i>	Vine maple	FAC-	container
<i>Oemleria cerasiformis</i>	Indian plum	FACU	container
<i>Physocarpus capitatus</i>	Pacific ninebark	FACW-	container
<i>Salix scouleriana</i>	Scouler's willow	FAC	container/ live stake

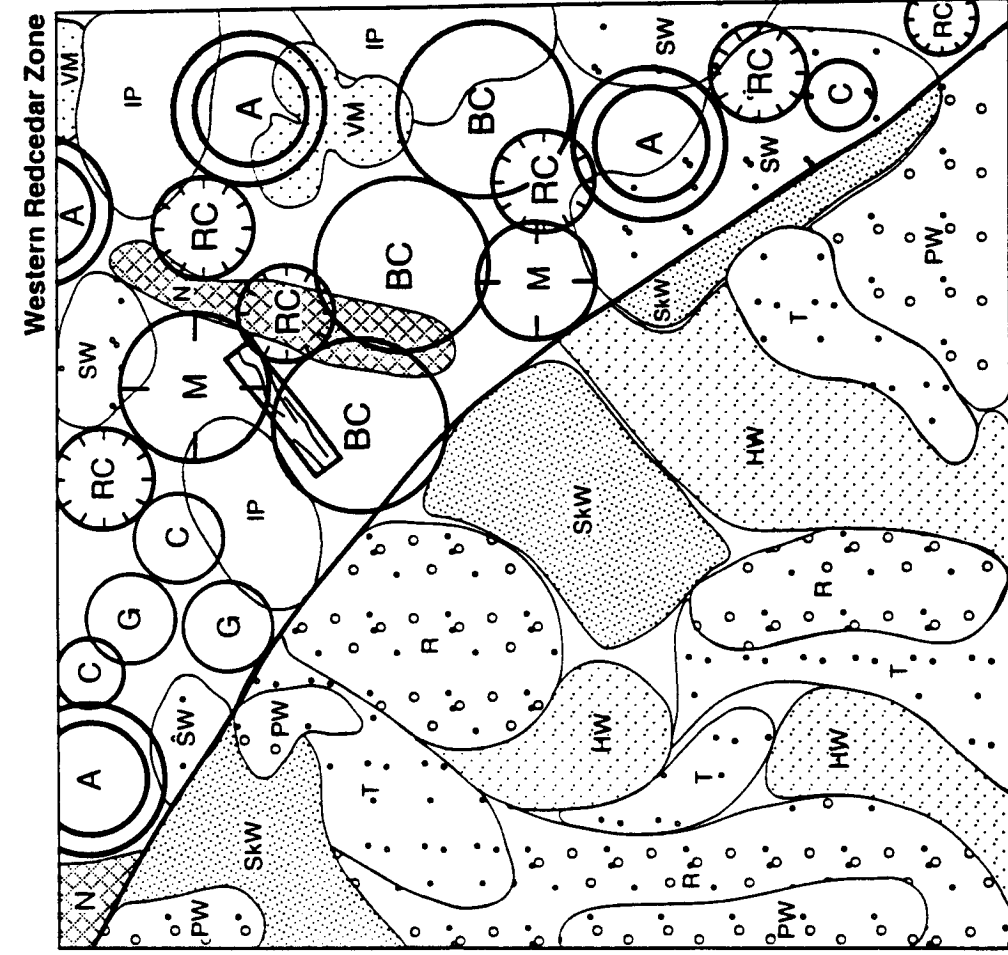
Existing Wetland Enhancement

The existing emergent wetlands will be enhanced by planting them with various forested and shrub communities, including black cottonwood/willow, red alder/salmonberry, and Oregon ash, and willow/red osier dogwood plant associations (see Tables 7.3-3 through 7.3-5 and 7.3-8). Trees and shrubs included in these associations will be infill-planted into the existing wetland vegetation. Wetland enhancement communities will be planted at the existing ground elevations, between elevations 45 and 49 ft.

Forested Buffers

The mitigation site will be protected by 100-ft forested buffers along its boundaries. In addition, upland forest between the existing wetland and the newly created wetlands will create an upland/wetland mosaic to increase habitat diversity (Appendix E, Sheets L5 through L10). Approximately 15.9 acres of forested buffer and upland will be established.

Buffer areas on the site range from moist upland areas to wetter transitional areas between uplands and wetlands. Transitional areas between uplands and wetlands will be planted with the western redcedar association (see Table 7.3-7), while upland areas will be planted with the mixed forest association (see Table 7.3-6).



Western Redcedar Zone

- G Grand Fir
- M Bigleaf Maple
- RC Western Redcedar
- BC Black Cottonwood
- A Red Alder
- C Cascara
- SW Scouter's Willow
- N Pacific Ninebark
- VM Vine Maple
- IP Indian Plum
- Hydroseeding
- Downed Log

Shrub Zone

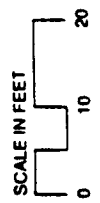
- R Red Osier Dogwood
- HW Hooker's Willow
- T Twinberry
- PW Pacific Willow
- SKW Sitka Willow
- Hydroseeding

Willow/Red Osier Dogwood Shrub Zone

Note: See Appendix E Sheets L9 and L10 for more details

Port of Seattle/Natural Resource Mitigation Plan/556-2912-001/01(03) 12000 (K)

**Figure 7.3-9
Typical Planting Plan
for the Western Redcedar
and the Shrub Planting Zones**



Upland areas disturbed during wetland construction will be seeded using a mix of low-growing grass species (see Table 7.3-2) prior to planting. Trees and shrubs will be planted at densities sufficient to attain the stem density and canopy cover performance standards identified for forested wetland habitat (see Table 7.1-2).

7.3.4.2 Shrub Wetland Community

Willow/Red Osier Dogwood Association

The shrub wetlands will be planted with a willow/red osier dogwood association (Table 7.3-8; see Figure 7.3-9). Shrubs will be planted approximately 4 to 6 ft on-center. This association will occupy wetter areas of the site that are inundated during the winter months and have saturated soils into the summer. Shrub wetlands will be planted between 44 and 47 ft in the western basin, and between 41 and 42 ft in the eastern basin (Appendix E, Sheets L5 through L10).

Table 7.3-8. Proposed plant species list for the willow/red osier dogwood shrub zone.

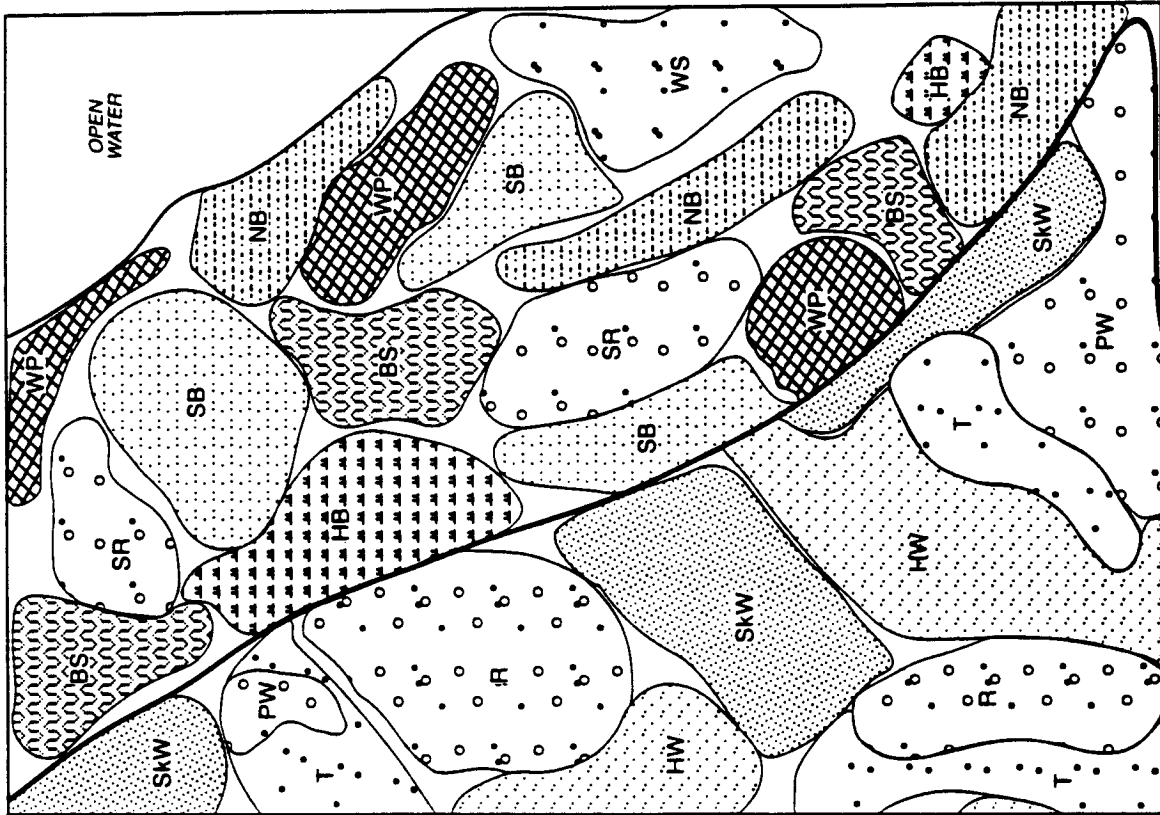
Scientific Name	Common Name	Indicator Status	Condition	Comments
<i>Cornus stolonifera</i>	Red-osier dogwood	FACW	container/ live stake	Shrubs would be planted in approximately 85% to 90% of the shrub zone at spacings ranging from 5 to 8 ft on-center.
<i>Lonicera involucrata</i>	Twinberry	FAC+	container	
<i>Salix hookeriana</i>	Hooker's willow	FACW-	container/ live stake	
<i>Salix lasiandra</i>	Pacific willow	FACW+	container/ live stake	
<i>Salix sitchensis</i>	Sitka willow	FACW	container/ live stake	

7.3.4.3 Emergent Wetland Community

Beaked Sedge/Water Parsley Association

Emergent wetlands in the excavated basins will be planted with native emergent species common in the Green River Valley and the northern Puget Sound region. Since wetland hydrology is designed to create both seasonally and permanently flooded areas, plants that are tolerant of extended flooding and soil saturation would be established in these areas. The emergent zones will be planted with an herbaceous community dominated by native sedge and rush species such as beaked sedge, slough sedge, water parsley, small-fruited bulrush, and narrow-leaved bur-reed (Table 7.3-9; Figure 7.3-10; Appendix E, Sheets L5 through L10). Emergent communities will be planted in the wettest portions of the site with year round soil saturation and some areas of permanent standing water. Emergent communities will be planted below approximately between 44 ft in the western basin and 41 ft in the eastern basin.

Beaked Sedge/Water Parsley Emergent Zone

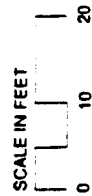


Willow/Red Osier Dogwood Shrub Zone

- Emergent Zone**
- Beaked Sedge (BS)
 - Water Parsley (WP)
 - Common Spike-Rush (SR)
 - Water Smartweed (WS)
 - Hardstem Bulrush (HB)
 - Small-fruited Bulrush (NB)
 - Narrow-leaf Bur-reed (R)
 - Hydroseed Mix/
Natural Colonization

- Shrub Zone**
- Red-Osier Dogwood (R)
 - Hooker's Willow (HW)
 - Twinberry (T)
 - Pacific Willow (PW)
 - Sitka Willow (SKW)
 - Hydroseeding

Note: See Appendix E Sheets L9 and L10 for more details
 Port of Seattle/Natural Resource Mitigation Plans 2012.001/0103) 12/00 (K)



**Figure 7.3-10
 Typical Planting Plan
 for the Emergent and
 Shrub Planting Zones**

Table 7.3-9. Proposed species list for the beaked sedge/water parsley emergent zone.

Scientific Name	Common Name	Indicator Status	Condition
<i>Carex rostrata</i>	Beaked sedge	OBL	plug/container
<i>Eleocharis palustris</i>	Common spike-rush	OBL	plug/container
<i>Oenanthe sarmentosa</i>	Water parsley	OBL	container
<i>Polygonum amphibium</i>	Water smartweed	OBL	container
<i>Scirpus acutis</i>	Hardstem bulrush	OBL	plug/container
<i>Scirpus microcarpus</i>	Small-fruited bulrush	OBL	plug/container
<i>Sparganium emersum</i>	Narrow-leaf bur-reed	OBL	plug/container

The typical growth pattern for emergent marsh plants is in monotypic patches with some interspersions in open, less densely vegetated areas, and proposed planting would mimic this pattern (See Figure 7.3-10). Planting shoots with rhizomes 18 inches on-center in monotypic stands of varying size, in combination with seeding a mix of emergent species (see Table 7.3-2) in the areas between patches should achieve that result. Because ponding in emergent areas is expected well into the early summer, planting of emergent species would occur during the fall months when soils are becoming saturated, but before water levels reach their winter maximum.

7.4 IMPLEMENTATION

The following sections describe the general implementation sequence for the Auburn site. Table 7.4-1 presents a proposed implementation timeline for Auburn mitigation projects.

7.4.1 Pre-construction Meeting

Oversight during construction of the wetland mitigation will be required to ensure that the contractors follow the plans and specifications. Prior to any site work, a pre-construction meeting will be held with the Port, general contractors, engineers, landscape contractors, landscape architects, and biologists to ensure that the work is constructed as designed, and that contractors understand and comply with all environmental permit conditions. Both a civil engineer and wetland ecologist will be available for on-site inspections and approvals of all work during construction.

7.4.2 Site Preparation and Planting

7.4.2.1 Existing Wetlands

The majority of the existing wetlands will not be cleared of vegetation or graded during site grading and excavation (Appendix E, Sheets C3 through C6). Non-native vegetation in the existing

Table 7.4-1. Proposed Implementation Timeline for Auburn Wetland Mitigation Projects.

Project/Activity	Year (Year One Starts with the First Construction Season After the Date Permits Are Issued)															
	Year 1				Year 2				Year 3							
	J	F	M	A	J	J	A	M	J	J	A	M	J	J	A	M
Auburn Wetland Mitigation																
Preconstruction meeting																
TESC, Site Preparation																
Begin dewatering																
Excavate and mass grade east basin																
Fine grade east basin, place wetland soil																
Mow and herbicide buffer																
Construct water control structure and connection to east basin																
Install irrigation in east basin and buffer																
Install groundwater monitoring wells and staff gages and begin hydrology monitoring																
Hydroseed graded portions of site																
Produce grading record drawings																
Install plants in east basin and buffer																
Produce planting plan record drawing																
Excavate and mass grade west basin																
Fine grade west basin, place soils																
Mow existing wetland, mow, herbicide and disc buffer																
Install irrigation in west basins, existing wetland and buffers																
Construct water control structure																
Install groundwater monitoring wells and begin compliance monitoring																
Hydroseed open areas																

AR 048913

Table 7.4-1. Proposed Implementation Timeline for Auburn Wetland Mitigation Projects (continued).

Project/Activity	Year (Year One Starts with the First Construction Season After the Date Permits Are Issued ¹)																						
	Year 1				Year 2				Year 3														
	J	F	M	A	J	J	A	S	O	N	D	J	F	M	A	M	J	J	A	S	O	N	D
Produce grading and irrigation record drawings																							
Install plants in west basin, existing wetland and buffers																							
Closeout of temporary access roads, staging areas																							
Produce planting plan record drawings, conduct baseline monitoring for entire site																							
Begin compliance monitoring ²																							

¹ Plant procurement for all projects will be implemented six to twelve months prior to the anticipated planting date to ensure that plants in the specified quantities and species are available by the scheduled planting date. Implementing mitigation projects may vary from this proposed schedule depending upon coordination with other MPU projects and contract obligations.

² Compliance monitoring begins for all parameters except hydrology; monitoring continues for 10 years; hydrology monitoring begins once grading is complete.

wetlands will be managed before installing native plants to reduce competition, and to control weeds. Management will include reducing cover and vigor of existing non-native vegetation. Plant installation will occur between March and October, and weed management should occur immediately prior to installing plants.

Prior to the scheduled plant installation in the existing wetlands, existing vegetation will be mowed and maintained at a maximum height of approximately 6 to 12 inches. Enhancement plantings will be installed per the planting schedule (Appendix E, Sheets L5 through L10). Native trees and shrubs will be installed in clumps of 5 to 10 individuals, with a weed barrier mulch applied around the base of each plant. Mowing may occur periodically to maintain the grasses at a height of 12 inches or less. Mowing between the planted areas may be necessary for the first 3 to 5 years of the monitoring period to minimize competition between the planted stock and existing pasture grasses or to control invasive plants.

This weed management strategy is expected to maximize the success of plant establishment. Over time, the areas in between the planted clumps will fill in with native wetland trees and shrubs through the increase in cover from the initial planted stock, as well as colonization of new areas.

7.4.2.2 Protective Buffers

Buffers at the Auburn site will be established in a 100-ft-wide zone around the perimeter of the mitigation site, as well as in the areas between the existing wetlands and newly created wetlands (Appendix E, Sheets C3 through C6). The existing upland areas, including the buffer around the wetlands, are currently dominated by non-native pasture grasses and forbs. To reduce competition from existing vegetation and to control weeds prior to planting, the cover of existing vegetation will be reduced, and soils will be disced to prepare a substrate for the hydroseed mix and the planted stock. During early to mid summer, existing vegetation will be mowed to a maximum height of approximately 6 to 12 inches. The vegetation will be allowed to grow for about 2 weeks to produce new shoots and leaves, and then herbicide will be applied per the specifications. Approximately 2 weeks after the herbicide application, the area will be thoroughly disced to mix the upper soil profile, irrigation will be installed, and a hydroseed/mulch mix applied. The following spring and summer, plants will be installed in the buffer planting zones.

Depending on the timing of mitigation construction, it may not be possible to prepare the buffer area, install irrigation, and apply hydroseed in time for the hydroseed to become established before the winter season. Therefore, there will be two options for preparing the upland and existing wetland buffers. Option one is to complete the entire sequence outlined above, if all the steps can be completed by mid-September or earlier. This will allow the hydroseed time to establish cover and stabilize the soil before the winter rainy season. If the entire sequence cannot be completed by mid-September, then the existing vegetation should be left in place to stabilize the soil and prevent erosion during the winter. The discing and hydroseed steps will be omitted and the irrigation system and planted stock will be installed into the existing vegetation. If the existing vegetation is left in place in the buffer areas, planting will proceed as described above for the existing wetland areas.

7.4.3 Excavation and Grading

Prior to excavation and grading, the extent of all grading activities will be surveyed by a professional surveyor and staked in the field. The contractor will establish vertical and horizontal site controls and maintain them throughout the construction period. The limits of work will be identified and flagged in the field, wetlands and surface water features will be identified with orange barrier fencing, and the TESC measures will be installed.

Approximately 440,000 cy of soil will be excavated to form the new wetlands basins to the east and west of the existing wetlands. The top 12 inches of soil will be stripped and removed from the site. This surface material, as well as the majority of the excavated material, will be transported off-site and disposed of at an approved upland location. A portion of the excavated subsoils, which are composed of silts, clays, and fine sands, will be blended with composted organic matter and used as topsoil, to be placed after the new site grades are established. The topsoil blending operation will require temporary stockpiling and processing at either an on-site or off-site location.

The existing drainage channel, located north of the site, will be widened to connect the mitigation site with the 100-year floodplain and an existing ditch system near 277th Avenue South (see Appendix E, Sheet C8 Section 5).

Final grading and habitat log placement will be performed under the direction of the wetland scientist or landscape architect. If subsoils have become compacted during preliminary grading, the soil surface will be ripped and/or disced prior to spreading the amended top soil mix. The top soil mix will be placed to a depth of at least 12 inches.

7.4.4 Construction Access Roads, Staging Areas, and Maintenance Roads

In addition to any temporary access and/or haul roads, temporary construction and maintenance roads will be required on the mitigation site. Temporary maintenance roads will be constructed around each wetland basin to provide vehicular access during planting, and for the early site maintenance and monitoring period. Temporary gravel paths will provide foot and small vehicle access to the interior of the site during the planting period.

7.4.4.1 Staging Areas, Temporary Haul, and Access Roads

On completion of earthwork and planting phases, temporary staging areas, access, and haul roads will be removed, prepared for planting, and planted. Staging areas and/or access roads that are not within the mitigation site boundaries will be cleared of construction equipment and debris and soils will then be ripped or disced to break up compacted layers and prepare a suitable substrate for planting. Except for where these areas cross wetland, they will be hydroseeded with the low-grow erosion control seed mix specified for the upland buffers (see Table 7.3-2). Where they cross wetlands, the wetland hydroseed mix will be used.

Temporary staging areas or access roads within the mitigation site will be removed and planted. These areas will be cleared of construction equipment and debris, road materials will be removed, and soil surfaces will be prepared for planting and planted according to the planting plan. For example, where a temporary haul road occurs in an area designated as western redcedar on the

planting plans (Appendix E, Sheets L1 through L5), the area will be planted with the western redcedar association once the road is removed. Preparation of these areas for planting may include deep ripping or discing, depending on the degree of soil compaction, and the addition of organic mulch (as specified for the rest of the site).

7.4.4.2 Gravel Paths and Maintenance Roads

Temporary gravel paths in the mitigation area provide access for planting, initial maintenance, and monitoring. The gravel paths will be decommissioned after five complete growing seasons following completion of planting, if the areas have met plant cover and survival performance standards for 2 consecutive years. If the areas are not meeting cover performance standards at the end of 5 years, the gravel paths will be decommissioned when basins have met plant cover and survival performance standards. Decommissioning will include removing path materials, preparing the soil surface for planting (e.g., ripping and/or tilling), and planting according to the planting plan.

The temporary maintenance roads will be removed after five growing seasons if the areas they serve meet cover performance standards for 3 consecutive years. The road materials will be removed and soil surfaces treated to provide a suitable medium for plant growth (i.e., ripping and/or discing). The road area will be planted with fast-growing species from the mixed forest plant schedule (i.e., Douglas fir, red alder, black cottonwood, bald-hip rose).

Maintenance roads along the west, north, and south sides of the site, may be retained throughout the 10-year monitoring period for maintenance and security for the site (i.e., to manage weed control, any necessary replanting, prevent dumping, etc.). At the end of the 10-year monitoring period, the Port will consult with regulatory agencies to determine if the maintenance roads should be decommissioned, or if they should be retained to allow for on-going maintenance, or security needs. If it is determined the maintenance roads should be removed, they will be planted as described above for the construction haul and access roads.

7.4.5 Erosion Control

Prior to any site preparation and grading, sediment and erosion control measures will be implemented to protect on- and off-site aquatic systems from sedimentation. Generally, construction of the wetland basins will not be prone to off-site migration of sediments due to the level topography of the site and the lack of surface water features in or adjacent to the site. In areas where fine sediments could potentially occur in surface waters, adjacent properties, or existing wetlands due to construction activities, a variety of erosion control measures will be employed. Staging areas and existing wetlands will be protected with silt fencing. Stockpiled soil left in place for more than 3 weeks will be stabilized with an approved native hydroseed mixture, tarp, or appropriate BMP. In addition, a native erosion control grass seed mixture will be used to stabilize the soil in the graded portions of the site until native vegetation can be installed.

To reduce tracking of mud onto paved roads, the site entrance roads will be stabilized using a pad constructed of quarry spalls. Vehicles and/or their tires will be washed or brushed prior to leaving the site during periods when track-out of mud could occur.

7.4.6 Irrigation

After all grading activities have been completed, a temporary irrigation system will be installed throughout the site. Installation of the irrigation system will be coordinated with grading and planting steps to ensure that irrigation is installed prior to plant installation. Installation of the irrigation system will be below ground in all areas that will be cleared and graded; however, the system will be installed above ground in the existing wetlands. The irrigation system will remain in place until the plants become established, which is anticipated to take 2 to 5 years. The temporary systems will then be decommissioned and above-ground parts of the system will be removed.

7.4.7 Establish Native Wetland and Upland Buffer Vegetation

All planting zone boundaries will be surveyed by a professional surveyor, and staked and flagged in the field according to the planting plan. A landscape architect or wetland scientist will observe plant installation to ensure that plants are installed properly and according to the plans and specifications. The contractor will be responsible for ensuring that plants are not damaged during transport, staging, or installation, and will be responsible for plant survival and health during the first year following planting.

Due to the large number of plants required to cover the entire buffer, planting may occur in phases. An initial planting of rapidly growing plants tolerant of full sun will be followed by a second planting of more slowly growing species that tolerate or require shade. Planting activities will most likely occur during the spring and fall months to avoid potential disturbance to wintering bald eagles in the vicinity of the Green River.

To provide additional protection to the site from people and pets, the fence line will be densely planted with species from the mixed forest community type to provide a physical and visual screen. Dense planting along the fence line will include Douglas fir, black hawthorn, tall Oregon grape, bald-hip rose, and big-leaf maple (Appendix E, Sheet L10, Detail 6)

7.4.8 Record Drawings Report and Monitoring

On completion of earthwork, site topographs will be surveyed and a report containing record drawings for the earthwork phase will be prepared and submitted to regulatory agencies. The planting plan will be reviewed and adjusted if necessary to match constructed grades and site conditions. Adjustments may include moving the boundaries of planting zones or adjusting species compositions to ensure successful establishment of the plant communities. Any necessary adjustments to the planting plan will be submitted to regulatory agencies with the earthwork record drawings and report.

Upon completion of planting (i.e., completion of all planting phases), a complete set of record drawings (including both earthwork and planting as-builts) documenting the constructed mitigation site will be developed and submitted to regulatory agencies. Baseline monitoring (year 0 monitoring) will be conducted on completion of planting to document baseline ecological conditions on the site. Compliance monitoring consistent with the monitoring plan outlined in Chapter 4 of this document will begin during the first growing season after submittal of the

complete set of record drawings (i.e., monitoring year 1). Monitoring reports will be submitted to the regulatory agencies consistent with the schedule described in Chapter 4 of this document.

7.4.9 Construction Steps

The following sections provide a general outline of the construction and post-construction steps necessary to implement the Mitigation Plan.

7.4.9.1 General Conditions

- All site work will be consistent with permit conditions and City of Auburn grading permit.
- Pre-construction meeting will be held with contractor, architect/engineer, and wetland scientist to review submittals, work plan, schedules, and permit conditions.
- The contractor will be responsible for ensuring that the work is performed in accordance with all permit conditions and shall maintain a copy of permits on-site.
- During construction, hydroseed or mulch will be applied to all open areas after grading consistent with City of Auburn grading permit.
- All areas of exposed soil will be hydroseeded or mulched by September 15th to stabilize the site prior to the start of the rainy season.
- Plant procurement must be coordinated with the construction schedule to ensure that specified plant quantities and species are available when they are needed.

7.4.9.2 Site Preparation

- Vertical and horizontal site controls will be established and maintained throughout the construction period.
- Identify and flag limits of work for the mitigation site.
- Install fencing (orange barrier) around existing wetlands and outlet ditches.
- Implement TESC plan.
- Maintain security of the site through construction; install security fence around site.
- Establish temporary site access roads and wetland crossings.
- Establish staging and stockpile areas.
- Implement a spill control plan and identify fueling areas.
- Install site dewatering system (pumping wells, manifold piping, and discharge structure).
- Install temporary utilities (e.g., electric power and irrigation mains).

7.4.9.3 Outlet Channel and Weir Construction

- Install temporary sediment and erosion control measures.

- Recontour ditch at the north end of site (as needed), construct water control structure and channel connecting to the east wetland basin.
- Install erosion control matting and hydroseed open areas.
- Install control weir.

7.4.9.4 East Wetland Basin and Buffer

- Clear site of brush and fence, etc.
- Strip top 12 inches of soil material and dispose off site in an approved upland disposal area.
- Start dewatering.
- Excavate east side of wetland basin.
- Mix subsoils with organic compost and stockpile; stabilize consistent with grading permit requirements.
- Complete fine grading of east side of wetland basin.
- Disc soils where compacted after grading.
- Place amended soils 12 inches deep over entire east side basin and disc into subsoils.
- Mow existing vegetation in upland buffer areas.
- Install habitat logs and snags.
- Install irrigation system in east basin; restore disturbed grades as needed.
- Install irrigation in upland buffer.
- Test irrigation system.
- Install erosion control matting as needed.
- Remove haul roads, access roads, dewatering ponds/pipes, staging areas, etc., not needed for planting of the existing wetland or west basins, return staging areas/access roads, etc. to grade.
- Apply hydroseed/mulch to east basin (wet and transition seed mixes) and upland buffer (low-grow mix) per specifications.
- Winterize irrigation system.
- Produce grading record drawings.
- After grading is complete, install plants in east basin; phase planting if necessary.
- Install plants in upland buffer and in the area between the maintenance roads and the fencing.
- Place mulch or other materials 4 to 6 inches deep around plants as a weed barrier.

7.4.9.5 Preparation and Enhancement Planting of Existing Wetland and Buffer

- Mow existing vegetation in wetland and buffer.
- Disc and install irrigation in the buffer.
- Hydroseed buffer with transition seed mix.
- Install above-ground irrigation in existing wetland.
- Install additional plants in the existing wetland and surrounding buffer areas.
- Place sterile organic mulch (e.g., wood fiber) 4 to 6 inches deep between plants as a weed barrier.
- Perform maintenance mowing in areas between enhancement plantings in the existing wetland.

7.4.9.6 West Wetland Basin

- Clearing (site of brush, fence, etc.)
- Strip top 12 inches of soil material and dispose off-site in an approved upland disposal area.
- Start dewatering.
- Excavate west side wetland basin.
- Mix subsoils with organic compost and stockpile; stabilize consistent with grading permit requirements.
- Complete fine grading of west side basin.
- Disc soils that are compacted by grading.
- Place amended soils 12 to 24 inches deep over entire west side basin.
- Mow existing vegetation in upland buffer areas.
- Install irrigation system and restore disturbed grades as needed.
- Test irrigation system.
- Install habitat logs.
- Install erosion control matting as needed.
- Apply hydroseed or mulch to west basin (wet and transition seed mixes) and upland buffer (low-grow seed mix) per specifications.
- Winterize irrigation system.
- Produce grading record drawing (as-built).
- After grading is complete, install plants.
- Place organic mulch (e.g., wood fiber) 4 to 6 inches deep between plants as a weed barrier.

7.4.9.7 Closeout

- Remove temporary haul/access roads.
- Remove construction equipment and debris.
- Hydroseed and/or install plants in temporary staging areas or access roads within the mitigation site boundaries.
- Hydroseed erosion control mix in temporary staging areas/access roads outside the mitigation boundaries.

7.4.9.8 Record Drawings, Monitoring, and Maintenance

- Produce irrigation and plant installation record drawings (i.e., 'as-builts').
- Conduct baseline monitoring and complete baseline report including record drawings, results of baseline monitoring, and final monitoring plan (e.g., locations of monitoring plots, baseline conditions).
- Begin compliance monitoring after grading is complete; submit annual monitoring reports for 10-year monitoring period.
- Conduct maintenance (e.g., weed management) and implement any necessary contingency measures to meet performance standards.

7.5 MONITORING AND PERFORMANCE STANDARDS

The mitigation site will be monitored for a 10-year period, with monitoring focusing on collecting the physical and biological data necessary to determine if the performance standards, and ultimately the ecological benefits of the mitigation are met (see Table 7.1-2). Monitoring reports will summarize the ecological condition of the site and document compliance with performance standards. If necessary, specific contingency actions and schedules for implementing contingency measures will be recommended. The first phase of monitoring will be to complete record drawings and a baseline monitoring report, as described below in Section 7.5.1. Section 7.5.2 describes specific monitoring activities and schedules for the mitigation site.

7.5.1 Record Drawings and Baseline Monitoring Report

Conditions on the mitigation site following completion of construction will be documented with record drawings and a baseline monitoring report. This report will verify that the mitigation has been constructed as designed, or to document any deviations from the plan. Any significant deviations from the mitigation design will be noted, and submitted to ACOE for approval. The baseline report will also include documentation of all sampling locations for future monitoring activity. A detailed map of the site will be prepared from field surveys, and will include the following information:

- Site topography at 1-ft contour intervals and selected spot elevations.
- Locations of major plant community boundaries.

- Locations of surface water and control structures.
- Locations of vegetation transects, photograph points, groundwater wells, staff gages, and other sampling points.

Baseline monitoring data will be collected to provide the basis for evaluating future changes on the mitigation site, consistent with the approach and methods outlined for all Port mitigation projects in Chapter 4 of this document. Results of the baseline monitoring will be compared to the established design criteria and performance standards for the mitigation site (see Table 7.1-2).

7.5.2 10-Year Monitoring Plan

Monitoring activities during the 10-year monitoring period will focus on the collection of vegetation, hydrology, and wildlife data to determine wetland function and performance, and compliance of the mitigation site with the performance standards. The monitoring schedule and methods for the mitigation site are summarized in Table 7.5-1.

7.5.2.1 Vegetation Monitoring

Vegetation monitoring will measure establishment of native plant communities on the site. The development of native plant communities will be a key indicator of how well wetland and upland functions are being restored and enhanced by the mitigation. Vegetation is also an indicator of wildlife habitat, as well as having a significant influence on hydrologic and water quality functions.

Data describing plant species composition, density, and cover will be collected along permanent vegetation transects or within permanent plots. Walk-through surveys will be made to estimate annual shoot growth, survival rates, and vertical and horizontal vegetation structure. Photographs can provide qualitative documentation of plant community development over time by evaluating variables such as cover, species composition, height, and vertical structure. Therefore, photographs will be taken along transects and at appropriate viewpoints to document the extent and nature of plant cover. Results of the vegetation monitoring will be used to determine if performance standards for plant survival, cover, density, and species composition are met in each monitoring year.

7.5.2.2 Hydrology

Data on site hydrology will be collected to evaluate the duration and extent of flooding and/or soil saturation in each wetland type on the mitigation site. Both surface and groundwater hydrology will be monitored using staff gages or groundwater monitoring wells, and field observations. Surface water levels at staff gages will be recorded monthly for the first 3 years after construction is complete, and three times per year thereafter. Permanent groundwater monitoring wells will be installed throughout the site to measure groundwater depths. Wells will be placed within existing wetlands, and at representative sites in the newly constructed forested, shrub, and emergent plant communities. Depths to the water table will be recorded monthly for the first 3 years after construction is complete, and three times per year thereafter (see Table 7.5-1).

Table 7.5-1. Auburn Wetland Mitigation Site monitoring methods and schedule.

Design Objective	Performance Standard	Method	Frequency	Wetland Vegetation Zone	Data Collection Year (calculated as years after construction is complete)													
					0	1	2	3	4	5	6	7	8	9	10			
Forested Wetland Vegetation	In-kind replacement ratio	Aerial photographic or ground-based mapping	May	All	X	X	X	X	X	X	X	X	X	X	X	X		
		Walk-through surveys and vegetation sampling (plots, transects, or plotless techniques) to document all plant species present	July	All	X	X	X	X	X	X	X	X	X	X	X	X		
	Species composition	Vegetation sampling	July	All		X	X	X										
		Measure by plot sampling method along transects	July	PFO, PSS, Buffer				X	X	X							X	
	Plant Survival	Walk-through surveys to estimate annual shoot growth and survival rates	July	All		X	X	X	X	X	X	X	X	X	X	X	X	
		Vegetation structure	Describe from walk-through surveys, incorporating data from above analysis as available	July	All		X	X	X	X	X	X	X	X	X	X	X	
	Shrub Wetland Vegetation	In-kind replacement ratio	Aerial photographic or ground-based mapping	May	PSS	X	X	X	X	X	X	X	X	X	X	X	X	
			Walk-through surveys to document all plant species present by vegetation sampling (plots, transects, or plotless technique)	July	PSS	X	X	X	X	X	X	X	X	X	X	X	X	
		Species composition	Vegetation sampling	July	All		X	X	X									
			Measure by line-intercept method along transects	July	PSS				X	X	X	X	X	X	X	X	X	
Plant Survival		Walk-through surveys to estimate annual shoot growth and survival rates	July	PSS		X	X	X	X	X	X	X	X	X	X	X		
		Vegetation structure	Describe from walk-through surveys, incorporating data from above analysis as available	July	PSS		X	X	X	X	X	X	X	X	X	X		

AR 048924

Table 7.5-1. Auburn Wetland Mitigation Site Monitoring Methods and Schedule (continued).

Design Objective	Performance Standard	Method	Frequency	Wetland Vegetation Zone	Data Collection Year (calculated as years after construction is complete)												
					0	1	2	3	4	5	6	7	8	9	10		
	Vegetation structure	Describe from walk-through surveys, incorporating data from above analysis as available	July	PSS	X	X	X	X	X	X	X	X	X	X	X	X	X
Emergent Wetland Vegetation	In-kind replacement ratio	Aerial photographic or ground-based mapping	May	PEM	X	X	X	X	X	X	X	X	X	X	X	X	X
	Species composition	Walk-through surveys to document all plant species present	July	PEM	X	X	X	X	X	X	X	X	X	X	X	X	X
	Herbaceous plant coverage	Measure by plot sampling method along transects	July	PEM	X	X	X	X	X	X	X	X	X	X	X	X	X
	Plant growth	Walk-through surveys to estimate annual shoot growth and survival rates	July	PEM	X	X	X	X	X	X	X	X	X	X	X	X	X
	Vegetation structure	Describe from walk-through surveys, incorporating data from above analysis, as available	July	PEM	X	X	X	X	X	X	X	X	X	X	X	X	X
Wetland Hydrology	Soil saturation	Depth from the soil surface to groundwater measured at permanent sampling stations in forested, shrub, and emergent wetland zones	Monthly February, June, September	PFO, PSS, PEM	X	X	X	X	X	X	X	X	X	X	X	X	X
	Surface water depth	Water depths measured at permanent sampling stations in shrub and emergent wetland zones	Monthly February, June, September	PFO, PSS, PEM	X	X	X	X	X	X	X	X	X	X	X	X	X
Wildlife	Habitat structure	Analysis of hydrologic and vegetation data from forested, shrub, and emergent wetlands	February, June	PFO, PSS, PEM	X	X	X	X	X	X	X	X	X	X	X	X	X

7-80

Natural Resource Mitigation Plan
Seattle-Tacoma International Airport
Master Plan Update

December 2010.
556-2012-001 (03)

G:\DATA\working\2012\556\2012\01\01\temp\2010 NRMPP (current version).doc

Table 7.5-1. Auburn Wetland Mitigation Site Monitoring Methods and Schedule (continued).

Design Objective	Performance Standard	Method	Frequency	Wetland Vegetation Zone	Data Collection Year (calculated as years after construction is complete)											
					0	1	2	3	4	5	6	7	8	9	10	
		Description of habitat structure from walk-through surveys	February, June	PFO, PSS, PEM	X	X	X	X	X	X	X	X	X	X	X	X
	Wildlife usage	Report wildlife species and activities on-site.	January, April, June, November	All	X	X	X	X	X	X	X	X	X	X	X	X
Long-term Protection	Buffers, adjacent land uses	Description of buffer vegetation and adjacent land uses, including proximity and screening.	June	All	X	X				X						X
		Description of adjacent vegetation and land uses.	June	All	X					X						X

7.5.2.3 Wildlife Habitat

Habitat structure (i.e. vegetation types, flooding, etc.) of the mitigation site will be monitored to evaluate whether performance standards are being met. These data will be supplemented with observations of wildlife using the site. Wildlife surveys will be conducted four times per year to record wildlife species and activities on site.²² A variety of techniques will be used to evaluate wildlife use and wildlife habitat attributes on the site. Techniques described in Ralph and Scott (1981), Ramsey and Scott (1979), and Reynolds et al. (1980) may be used to monitor bird numbers. Techniques described in Olson et al. (1997) may be used to sample pond-breeding amphibians and Corn and Bury (1990) for terrestrial amphibians.

7.6 SITE PROTECTION

The Port will execute and file restrictive covenants on the Auburn wetland mitigation site to provide permanent protection for the site. Copies of the restrictive covenants are provided in Appendix F. Language and conditions of these restrictive covenants have been revised to reflect discussions between the Port and ACOE, Ecology, FAA, and USDA-WSD.

The mitigation site will be marked with permanent signs and protected by fencing. Signs will clearly mark the area as a protected wetland mitigation site. The Port will inspect and maintain the signs and fencing on a regular basis.

7.7 MAINTENANCE AND CONTINGENCY PLANS

7.7.1 Routine Maintenance

Routine maintenance tasks (e.g., maintaining irrigation system, removing trash) and adaptive management/contingency measures (e.g., weed management, replacing plants) will occur during the monitoring period. Routine weed control does not include contingency measures that may be needed to keep invasive species cover below the 10 percent cover standard. These are discussed below under contingency measures.

The mitigation site has been designed to achieve final performance standards without significant ongoing maintenance. The need for maintenance is anticipated to decline during the monitoring period, as the mitigation has been designed to be self-sustaining in the long term. Some maintenance will continue for at least as long as the 10-year monitoring period.

Typical maintenance activities will include replacing dead plants, and weed control measures. For the first year following planting, the landscape contractor will be responsible for ensuring the health of planted material and for replacing dead or severely stressed plant material. After the first year, the Port will be responsible for maintaining plants and will replace plants as needed based on

²² Note that performance standards do not require wildlife surveys. Wildlife surveys will be conducted to provide additional information about the wetland that may be useful in making adaptive management decisions or implementing contingency measures.

performance standards and consistent with specified contingency measures. To achieve relatively rapid overstory development and structural diversity, trees will be planted closer together than would occur in natural, mature stands and may be fertilized. At the end of the 10-year monitoring period to allow better development of some trees, other trees may be cut or girdled (these would then be left as woody debris for wildlife habitat). This management activity will allow the remaining trees adequate space to reach full size, while providing additional microhabitat for animals in the downed or standing woody debris.

7.7.2 Contingency Measures

Contingency measures will be implemented consistent with the adaptive management approach if monitoring results show that specific performance standards are not being met. Specific performance standards and contingency measures for the mitigation site are given in Table 7.7-1. If conditions arise that have not been identified in this table, they will be evaluated on a case-by-case basis, and discussed with ACOE and Ecology. Based on these discussions, appropriate contingency measures will be developed and implemented.

7.7.2.1 Weed Management

If needed, a variety of weed control strategies are available to manage non-native invasive species, and these weed control strategies may be used as appropriate throughout the project. Specific control measures will be determined on a case-by-case basis, depending on the extent of the invasive species problem, the invasive species of concern, and the site condition. Steps in weed control may include (listed in order of preference), any of the following:

- Dense plantings of desired species that competitively exclude non-native species
- Use of mulch in the form of sterile straw or other biodegradable mulch
- Installation of biodegradable weed barrier cloth
- Mechanical removal of weeds by using weed whackers, hoeing, or hand-removal
- Applications of EPA-approved herbicides, as necessary

Reed canarygrass is present in wetland areas on and adjacent to the mitigation site, and this undesirable species could spread into mitigation wetlands via seed dispersal. To control the spread of reed canarygrass and to ensure the success of native plant establishment, contingency measures as well as routine maintenance actions may be required. Potential control measures include periodic mowing, reseeding with native wetland grasses, and/or treatment with an EPA-approved herbicide.

Because of the planting approach taken (hydroseeding, densely planting fast growing species, and very wet emergent areas), the need for long-term control of reed canarygrass on the site is not anticipated. The dense planting of forested vegetation, including a significant conifer component, will provide dense shade over much of the site. Shade from the forest canopy will greatly reduce the likelihood that reed canarygrass can persist on the site over the long term. The emergent wetlands are designed to be too wet for this species, and it is unlikely to out-compete native wetland plants once they are established in the emergent zone. Hydroseeding at the time of construction should also limit the ability of reed canarygrass to become established.

Table 7.7-1. Final performance standards, evaluation approach, and contingency measures for the Auburn wetland mitigation project.

Design Criteria	Performance Standard ¹	Evaluation Approach	Contingency Measures
Use a perched water table to establish wetlands at the approximate final grades of:	Wetland areas will meet the following hydrology criteria:	Measure hydrology using ground water monitoring wells and staff gages.	Minor regrading if necessary
West Basin:	In forested areas, soils will be saturated within the upper 12 inches for a minimum of 2 weeks during the growing season.	Modify surface drainage features or control elevations of drainage channels.	
41 ft to 38 ft in emergent wetlands			
42 ft to 41 ft in shrub wetlands			
45 ft to 42 ft in forested wetlands			
Below 38 ft in open-water wetland			
East Basin:	In shrub areas, soils will be saturated within the upper 6 inches for a minimum of 2 weeks during the growing season.		
42 ft to 44 ft in emergent wetlands			
44 ft to 46 ft in shrub wetlands			
46 ft to 49 ft in forested wetlands	In emergent zones, soils will be saturated to the soil surface for 6 months.		
Below 42 ft in open-water wetland			
Plant five forested wetland plant associations that are similar in composition to naturally occurring plant associations. Use native deciduous and evergreen species such as black cottonwood, Oregon ash, red alder, western redcedar, and Sitka spruce.	Forested wetlands will achieve cover at least 36 acres of the mitigation site. Native upland forest habitat will be established on approximately 16 acres of the mitigation site. Native tree and shrub species in the forested wetlands will be in a healthy, vigorous growing condition.	Measured using record surveys, vegetation monitoring, and mapping. Verify areas available for vegetation zones on completion of grading and prior to planting.	Replant as necessary to achieve desired vegetation. Make minor adjustments to planting areas to match as-built grades and planned vegetation zones.
Forested communities will have a native shrub understory with species such as salmonberry, twinberry, red-osier dogwood, red elderberry, willows, and vine maple.			

Table 7.7-1. Final performance standards, evaluation approach, and contingency measures for the Auburn wetland mitigation project (continued).

Design Criteria	Performance Standard ¹	Evaluation Approach	Contingency Measures
Plant native tree species at densities greater than 280 trees per acre). Plant native shrub species in forested communities at densities greater than 1,800 plants per acre.	<p>Forested wetlands will have at least 80% cover of native species by monitoring year 10.</p> <p>Forested wetlands will have no more than 10% cover of non-native invasive species by monitoring year 10.</p> <p>Average survival of planted stock will be at least 80% in the first 3 monitoring years. At this time tree species density will be at least 280 trees per acre in forested wetland areas and shrub density will be at least 1,800 individual plants per acre in areas of the forested wetland that are planted with shrubs. By the end of year 3, plant diversity in each stratum will not decrease by more than 10% from the number and type of plants installed at baseline.</p>	<p>Verify using record surveys and vegetation monitoring</p> <p>Vegetation sampling (plots, transects, or plotless techniques) to determine plant mortality, density, cover, and presence of invasive species.</p>	<p>Replant as necessary to meet required density.</p> <p>If standards are not met:</p> <ul style="list-style-type: none"> Select species that are better adapted to existing hydrologic conditions. Install additional plant material. Install protective collars to reduce herbivore damage. Control/reduce non-native invasive species. Implement integrated weed management plan, which may include test plots to evaluate potential control methods, use of mechanical removal, manual controls (i.e., chopping, digging) mowing, mulching, biological control, and/or herbicides.
Plant an association of native shrub wetland species that is similar in composition to naturally occurring shrub wetlands, including species such as Pacific willow, Hooker's willow, Sitka willow, red-osier dogwood, and twinberry.	Shrub wetlands will cover at least 6.0 acres of the mitigation site.	See above.	See above.
Plant native shrub species at densities greater than 2,100 plants per acre.	<p>Species composition in the shrub wetland will include at least a 5% component of each native species planted.</p> <p>Native shrub species will be in a healthy, vigorous growing condition.</p>	See above.	See above.

Table 7.7-1. Final performance standards, evaluation approach, and contingency measures for the Auburn wetland mitigation project (continued).

Design Criteria	Performance Standard ¹	Evaluation Approach	Contingency Measures
	Average survival of planted stock will be at least 80% in the first 3 monitoring years. At this time shrub density will be at least 2,100 individual plants per acre in shrub wetland areas.		
	Canopy cover of native species will be at least 80% by monitoring year 10.		
	Shrub areas will have no more than 10% cover of non-native invasive species by monitoring year 10. By the end of year 3, plant diversity in each stratum will not decrease by more than 10% from the number and type of plants installed at baseline.		
Plant an association of native emergent wetland species similar in composition to naturally occurring emergent wetlands. Use native species that are suited to seasonally and/or permanently flooded conditions, such as water parsley, hardstem bulrush, and common spike rush.	Emergent wetlands and open-water habitat will cover at least 6.8 acres of the mitigation site. Native emergent wetland species will contribute at least 90% of plant cover in areas planted with emergent species by monitoring year 10.	See above.	See above.
Plant native emergent species in approximately 0.05-acre monotypic patches at densities greater than 10,000 plants per acre (approximately 24 inches on-center).	Species composition (stem density or percent composition) in the emergent wetland will include at least a 5% component of each native species planted. Cover of native species will be at least 80% by monitoring year 10. Emergent areas will have no more than 10% cover of non-native invasive	See above.	See above.

7-86

Natural Resource Mitigation Plan
Seattle-Tacoma International Airport
Master Plan Update

December 2000
556-2912-001 (03)

G:\MFA\working\19111519\2010\mpra\2000\NRMP\current\version 11.doc

Table 7.7-1. Final performance standards, evaluation approach, and contingency measures for the Auburn wetland mitigation project (continued).

Design Criteria	Performance Standard ¹	Evaluation Approach	Contingency Measures
	species by monitoring year 10. By the end of year 3, plant diversity in each stratum will not decrease by more than 10% from the number and type of plants installed at baseline.		
Establish an approximately 100-ft-wide forested buffer around the perimeter of the mitigation site	An approximately 100-ft-wide buffer will extend around the perimeter of the site. The buffer will be densely planted with native trees and shrubs to provide site protection and discourage access to the site by people or domestic animals. Average survival of planted stock in the buffer will be at least 80% in the first 3 monitoring years. Canopy cover of native species in the buffer will be at least 80% by monitoring year 10. Canopy cover of non-native invasive species will be no more than 10% by monitoring year 10.	See above.	See above.
Provide year-round shallow water with patches of emergent vegetation as feeding habitat for dabbling duck species.	Permanently flooded emergent wetlands will have shallow-water habitat (<12 inches deep) near the edges, with emergent vegetation and bottom detritus interspersed throughout.	Hydrologic monitoring and vegetation surveys.	Replant or minor regrading as necessary.
Provide ponded water areas for water resting habitat.	Ponded water at least 26 inches deep will occur in open areas of at least 1 acre from December through May.	Hydrologic monitoring.	Minor regrading as necessary.

Table 7.7-1. Final performance standards, evaluation approach, and contingency measures for the Auburn wetland mitigation project (continued).

Design Criteria	Performance Standard ¹	Evaluation Approach	Contingency Measures
Plant forested wetland adjacent to shrub, emergent, and open-water habitats.	Perch sites in the forested canopy will overhang emergent wetland areas.	Vegetation monitoring, site mapping.	Replant as necessary.
Plant portions of the forested wetland with shrub understory species to provide a multiple-layered canopy adjacent to the shrub portion of the wetland.	Forested wetlands will have a shrub understory of approximately 1,800 individual plants per acre over 25% to 50% of the area, depending on the planting zone. Evidence of songbird nesting (nest, breeding territories, or observations of breeding behavior) will be present.	Seasonal surveys for wildlife.	
LWD (stumps and logs of native species) placed throughout the forested wetland to provide year-round cover for small mammals.	LWD placed at densities of 50 pieces per acre (approximately 25 ft on-center).	As-built surveys for wood placement and topography.	Supplement with more wood as necessary.
Low hummocks constructed in the shrub wetland areas to provide non-saturated soils for burrowing small mammals.	Shrub hummocks (with a minimum area of 150 ft ² at elevation 43 ft) at least 4 per acre in the shrub zone. Leaf litter and vegetative debris will be present to provide habitat for invertebrates. Evidence of small mammal use (nests, feeding signs, observations) will be present.	Vegetation surveys. Wildlife surveys.	
Provide attachment substrate for breeding amphibian species in areas of ponded water.	At least 50% of live and dead stems in ponded emergent wetland areas will be species with stem diameters less than 0.25 inch. Evidence of amphibian breeding (egg masses, larval stages) will be present.	Vegetation surveys. Amphibian surveys during the breeding season.	Replant as necessary.

December 2010
556-2012-001 (03)

G:\DATA\working\91255591\010\Imp\000\NRMP\current\version\1\1.doc

7-88

Natural Resource Mitigation Plan
Seattle-Tacoma International Airport
Master Plan Update

Table 7.7-1. Final performance standards, evaluation approach, and contingency measures for the Auburn wetland mitigation project (continued).

Design Criteria	Performance Standard ¹	Evaluation Approach	Contingency Measures
Screen the wetland from off-site areas.	Forest and shrub buffers (100-ft-wide) screen the site.	Vegetation surveys.	Replant as necessary.
Enhance habitat functions of existing wetland.	Plant sections of the existing wetland with native trees and shrubs at densities of at least 2,100 individual plants per acre for shrubs and at least 280 stems per acre for native tree	Vegetation sampling (plots, transects, or plotless techniques) to determine plant mortality, density, cover, and presence of invasive species.	<p>If standards are not met:</p> <ul style="list-style-type: none"> • Select species that are better adapted to existing hydrologic conditions. • Install additional plant material. • Install protective collars to reduce herbivore damage. • Control/reduce non-native invasive species. • Implement integrated weed management plan, which may include test plots to evaluate potential control methods, use of mechanical removal, manual controls (i.e., chopping, digging) mowing, mulching, biological control, and/or herbicides

¹ All hydrologic criteria (water depths, soil saturation, etc.) must be met during years of normal rainfall, which is considered to be years when rainfall amounts are statistically similar to the long term average $9p > 0.10$.

7.7.2.2 Reducing Herbivore Damage

Vegetation at newly planted mitigation sites can be vulnerable to browse by Canada geese, deer, voles, beaver, and other wildlife species. In order to avoid significant loss of planted species, a number of contingency measures may be necessary. Stem collars may be installed around the base of woody species or netting may be placed over some plantings. A combination of cayenne pepper and pruning wax applied to woody stems has been an effective deterrent to herbivory at the Auburn Race Track mitigation site and may be used here. These and other contingency measures may be employed on a case-by-case basis.

7.7.3 Performance Standards

In addition to overall goals and objectives, specific design criteria and performance standards (see Table 7.1-2) were developed to achieve the established wetland mitigation goals. Performance standards are measurable criteria that can be evaluated to demonstrate when a mitigation element has been successfully implemented. Performance standards were developed for each design objective (see Table 7.1-2). During the monitoring period, these performance standards will be evaluated to determine the need for contingency or adaptive management actions. At the end of the monitoring period, performance standards will be used to determine if the project has successfully met design objectives and goals.

Referencia

AR 048936

8. REFERENCES

- Adamus, P.R., E.J. Clairain, R.D. Smith, and R.E. Young. 1987. Wetland evaluation technique (WET). Volume II, Methodology. Department of the Army, U.S. Army ACOE of Engineers. Washington, D.C.
- Aquatic Resource Consultants. 1996. Electrofishing results from Miller Creek. Unpublished memorandum by Aquatic Resource Consultants to Gary Minton, Resource Planning Associates. Seattle, Washington.
- Auburn, City of. 1995. Comprehensive zoning map. Auburn, Washington.
- Bellevue, City of. 1984. Bellevue Urban Runoff Program. Bellevue, Washington.
- Bellevue, City of. 1996. City of Bellevue stormwater monitoring report for Sturtevant Creek. Bellevue, Washington.
- Booth, D.B. 1991. Urbanization and the natural drainage system—impacts, solutions, and prognosis. *The Northwest Environmental Journal*. 7:93-118.
- Booth, D.B. and L. Reinelt. 1993. Consequences of urbanization on aquatic systems—measured effects, degradation thresholds, and corrective strategies. In Proceedings Watershed '93. U.S. Bureau of Reclamation, March 21-23, Alexandria, Virginia.
- Booth, D.B. and R.R. Horner. 1995. Fundamentals of urban surface water management. Chapter IV, course manual for class offered in cooperation with University of Washington Engineering Professional Programs. Seattle, Washington. September 1995.
- Brinson, M.M. 1993. A hydrogeomorphic classification for wetlands. Technical report WRP-DE-4. U.S. Army Corps of Engineers Waterways Experiment Station. Vicksburg, Mississippi.
- Brown, E.R. 1961. The black-tailed deer of western Washington. Biological bulletin. Washington State Game Department. Olympia, Washington.
- Butler & Associates and Sheldon & Associates. 1992. Seattle-Tacoma International Airport wetland management plan. Report for the Port of Seattle. Seattle, Washington.
- Canfield, R. 1941. Application of the line intercept method in sampling range vegetation. *Journal of Forestry*. 39:388-394.
- Castelle, A.J., S. Luchessa, C. Conolly, M. Emers, E.D. Metz, S. Meyer, and M. Witter. 1992. Wetland mitigation banking. Washington State Department of Ecology, Publication 92-12. Olympia, Washington.

- CH2M Hill and Associated Firms. 1995. Draft environmental impact statement for the Des Moines Creek Technology Campus. Prepared for the City of Des Moines and Port of Seattle. Seattle, Washington.
- Chui, T.W., B.W. Mar, and R.R. Horner. 1982. Pollutant loading model for highway runoff. Proceedings of the American Society of Civil Engineers. *Journal of the Environmental Engineering Division*. 108 (EE6). pp. 1193-1211. Bellevue, Washington.
- Cosmopolitan Engineering Group. 1999. (in preparation) Seattle-Tacoma International Airport dissolved oxygen de-icing study. Prepared by Cosmopolitan Engineering Group for the Port of Seattle. Tacoma, Washington.
- Conover, M. R., W. C. Pitt, K. K. Kessler, T. J. Dubow, and W. A. Sanborn. 1996. Review of human injuries, illness, and economic losses caused by wildlife in the United States. *Wildlife Society Bulletin*. 23:407-414.
- Cooke Scientific Services Inc. 1996. Wetland and buffer functions and semi-quantitative assessment methodology. Cooke Scientific Services. Seattle, Washington.
- Corn, P.S. and R.B. Bury. 1990. Sampling methods for terrestrial amphibians and reptiles. Cary, A.B. and L.F. Ruggiero, (eds.) *Wildlife-habitat relationships: sampling procedures for Pacific Northwest vertebrates*. USDA Forest Service. General Technical Report. (PNW-GTR-256). Portland, Oregon.
- Cowardin, L.M., V. Carter, F.C. Golet, and E.T. LaRoe. 1979. Classification of wetlands and deep water habitats of the United States. U.S. Fish and Wildlife Service, U.S. Department of Interior. Washington, D.C.
- Daubenmire, R. 1959. A canopy-coverage method of vegetational analysis. *Northwest Science*, 33:43-64.
- David Evans and Associates, Inc. 1995. Wetland determination on the Riverbend Master Plan Community. Report by David Evans and Associates to Gentra Capital Corporation. Seattle, Washington.
- Des Moines Creek Basin Committee. 1997. Des Moines Creek Basin Plan. Des Moines Creek Basin Committee (City of SeaTac, City of Des Moines, Port of Seattle, and King County Surface Water Management). Seattle, Washington.
- Dorman, M.E., J. Hartigan, F. Johnson, and B. Maestri. 1988. Retention, detention, and overland flow for pollutant removal from urban stormwater runoff. Federal Highway Administration. (FWHA/RD-87/056): McLean, Virginia.
- Duwamish Coalition. 1996. Lower Duwamish Watershed Habitat Restoration Plan (Final Draft). Seattle, Washington.
- Ehrlich, P.R., D.S. Dobkin, and D. Wheye. 1988. The birder's handbook: a field guide to the natural history of North American birds. Simon & Shuster. New York, New York.

- Environmental Laboratory. 1987. U.S. Army Corps of Engineers wetland delineation manual. Technical Report Y-87-1, U.S. Army Corps of Engineers Waterways Experiment Station. Vicksburg, Mississippi.
- Federal Aviation Administration (FAA). 1994. Final environmental impact statement for the South Aviation Support Area. Port of Seattle. SeaTac, Washington.
- Federal Aviation Administration (FAA). 1996. Final environmental impact statement for proposed master plan update development actions at Seattle-Tacoma International Airport. Prepared for the Port of Seattle. SeaTac, Washington.
- Federal Aviation Administration (FAA). 1997a. Final supplemental environmental impact statement for the proposed master plan update at Seattle Tacoma International Airport. Port of Seattle. Seattle, Washington.
- Federal Aviation Administration (FAA). 1997b. Hazardous wildlife attractants on or near airports. Advisory Circular, 150/5200-33.
- Federal Aviation Administration (FAA). 1997c. Record of Decision for the Master Plan update development actions, Sea-Tac International Airport. July 3, 1997.
- Federal Emergency Management Agency (FEMA). 1989. Flood Insurance Rate Map, King County, Washington and Incorporated Areas. Panel 310 of 650, Map Number 53033c0310D. Effective Date September 29, 1989.
- Federal Interagency Committee for Wetland Delineation (FICWD). 1989. Federal manual for identifying and delineating jurisdictional wetlands. ACOE, U.S. EPA, USFWS, USDA Soil Conservation Service. Washington, D.C.
- Federal Register. 1986. Regulatory programs of the U.S. Army Corps of Engineers. Final Rule. Volume 51, No. 219; 33 CFR Parts 320 through 330. U.S. Government Printing Office. Washington, D.C.
- Federal Register. 1995. Federal guidance for the establishment, use and operation of mitigation banks (60 CFR 58605). 60:58605-58614. U.S. Government Printing Office. Washington, D.C.
- Fisheries and Oceans. 1980. Stream enhancement guide. Prepared for the Province of British Columbia, Ministry of Environment by Kerr Wood Leidel Associates Ltd. and D.B. Lister and Associates Ltd. Vancouver, Canada.
- Fore, L.S., J.R. Karr, and R. Wisseman. 1996. Assessing invertebrate responses to human activities: evaluating alternative approaches. *Journal of the North American Benthological Society*, 15(2):212-231.
- Hart Crowser. 2000a. Sea-Tac Third Runway Project, Borrow Areas 1, 3, and 4 – Projected impacts to wetlands. Unpublished memo by Hart Crowser to Ralph Wessels, Port of Seattle. Seattle, Washington. 17pp.

- Hart Crowser. 2000b. Sea-Tac Third Runway Project, Borrow Area 3 – Preservation of wetlands. Unpublished memo by Hart Crowser to Jim Thompson, HNTB. Seattle, Washington. 9pp plus attachments.
- Hauer, R. R. And G. Lamberti, Eds. 1996. *Methods in Stream Ecology*. Academic Press, San Diego, California.
- Herrera, and RW Beck. 2000. Description of existing conditions and alternatives for improvement, Gilliam Creek Basin, prepared for City of Tukwila, Public Works Department. Seattle, Washington.
- Hillman, T.W., J.R. Stevenson, and D.J. Snyder. 1999. Assessment of spawning and habitat in three Puget Sound streams, Washington. Prepared for Airport Communities Coalition. Des Moines, Washington. April 1999.
- Hitchcock, C.L. and A. Cronquist. 1973. *Flora of the Pacific Northwest*. University of Washington Press. Seattle, Washington.
- Horner, R.R., D.B. Booth, A. Azous, and C.W. May. 1996. Watershed determinants of ecosystem functioning. Proceedings of an Engineering Foundation Conference. American Society of Civil Engineers. Snowbird, Utah.
- Hruby, T., W.E. Cesanek, and K.E. Miller. 1995. Estimating relative wetland values for regional planning. *Wetlands* 15 (2):93-106.
- HWA GeoSciences, Inc. 1998. Geotechnical and dewatering evaluation Miller Creek relocation Seattle-Tacoma International Airport, Washington. Prepared for Parametrix, Inc. Lynwood, Washington.
- Karr, J.R. and E.W. Chu. 1999. Restoring life in running waters: Better biological monitoring. Island Press, Washington, D.C.
- Kent, M. and P. Coker. 1994. *Vegetation Description and Analysis – A Practical Approach*. John Wiley and Sons, Chichester, England.
- Kerans, B.L. and J.R. Karr. 1994. A benthic index of biotic integrity (B-IBI) for rivers of the Tennessee Valley. *Ecological Applications* 4(4): 768-785).
- King County. 1988. Seattle-Tacoma Area Update Plan. King County Planning and Community Development Division. King County, Washington.
- King County Capital Improvement Project Design Team (King County CIP Design Team). 1999. Des Moines Creek regional capital improvement projects preliminary design report. CIP Design Team, King County Department of Natural Resources, Water and Land Resources Division, Seattle, Washington.

- King County Department of Natural Resources (King County DNR). 1998. King County Surface Water Design Manual. King County Department of Natural Resources, Water and Land Resources Division. Seattle, Washington.
- King County Department of Parks, Planning and Resources, Planning and Community Development Division. 1990. King County sensitive areas map folio. Seattle, Washington.
- King County Surface Water Management Division (KCSWM). 1987. Miller Creek basin reconnaissance report no. 12. King County Department of Natural Resources. Seattle, Washington.
- King County Surface Water Management Division (KCSWM). 1994. Mean daily discharge from Lake Reba outflow at Lake Reba detention pond. Water years 1990-1994. Seattle, Washington.
- Kleindl, W.J. 1995. A benthic index of biotic integrity for Puget Sound lowland streams, Washington, USA. M.S. Thesis, University of Washington. Seattle, Washington.
- Kunze, L.M. 1994. Preliminary classification of native, low elevation, freshwater wetland vegetation in western Washington. Washington Natural Heritage Program, Department of Natural Resources. Olympia, Washington.
- Locke, G. 1997. Letter from Gary Locke, Governor of Washington, to Rodney Slater, Secretary of the U.S. Department of Transportation. Re: State certification of compliance with applicable air and water quality standards. State of Washington, Office of the Governor. Olympia, Washington.
- Lyon, L.A. and D.F. Caccamise. 1981. Habitat selection by roosting black birds and starlings: management implications. *Journal of Wildlife Management*. 45:435-443.
- Martin A.C., H.S. Zim, and A.L. Nelson. 1951. American wildlife and plants: A guide to wildlife food habits. Dover Publications. New York, New York.
- Montgomery Water Group. 1995. Hydrologic modeling study for Seattle-Tacoma Airport master plan update EIS. Montgomery Water Group. Kirkland, Washington.
- Mueller-Dombois, D. and H. Ellenberg. 1974. Aims and methods of vegetation ecology. John Wiley & Sons. New York, New York. 547p.
- Munsell Color. 1988. Munsell Soil Color Charts. Kollmorgen Corporation. Baltimore, Maryland.
- Natural Resources Conservation Service (NRCS). 1985. National food security manual. U.S. Department of Agriculture. Third Ed. Amend 2, December 1995. Washington, D.C.

- Natural Resources Conservation Service (NRCS). 2000. Hydric Soils List, King County area, Washington: Detailed soil map legend. Found at http://www.wa.nrcs.usda.gov/FOTG/SECTION2/hydric_lists/wa633hyd.doc Updated November 13, 2000.
- Nussbaum, R.A., E.D. Brodie, Jr, and R.M. Storm. 1983. Amphibians and reptiles of the Pacific Northwest. University of Idaho Press. Moscow, Idaho.
- Olson, D.H., W.P. Leonard, and R.B. Bury (eds.) 1997. Sampling amphibians in lentic habitats: methods and approaches for the Pacific Northwest. Society for Northwestern Vertebrate Biology. Olympia, Washington.
- Parametrix. 1992. South Aviation Support Area wetlands discipline report. Parametrix. Kirkland, Washington.
- Parametrix. 1995. Proposed wetland mitigation site, Phase I site assessment report. Prepared by Parametrix for the Port of Seattle. Kirkland, Washington.
- Parametrix. 1996. JARPA application for proposed master plan update improvements at Seattle-Tacoma International Airport. Prepared by Parametrix, Inc. for U.S. Army Corps of Engineers, Washington State Department of Ecology, and Washington Department of Fish and Wildlife. Seattle, Washington.
- Parametrix. 1996a. Environmental report: Port of Seattle master plan improvements wetland mitigation site, Auburn, Washington. Prepared by Parametrix for the Port of Seattle. Kirkland, Washington.
- Parametrix. 1996b. Natural resource mitigation plan for the proposed master plan update improvements at Seattle-Tacoma International Airport. Appendix P: Volume 3 of 7. Prepared by Parametrix for United States Department of Transportation, Federal Aviation Administration, and Port of Seattle. Kirkland, Washington.
- Parametrix. 1999. Preliminary comprehensive stormwater management plan for Seattle-Tacoma International Airport Master Plan improvements. Prepared by Parametrix for the Port of Seattle. Kirkland, Washington.
- Parametrix. 2000a. Comprehensive stormwater management plan for Seattle-Tacoma International Airport Master Plan Update improvements. Prepared by Parametrix for the Port of Seattle. Kirkland, Washington.
- Parametrix. 2000b. Wetland functional assessment and impact analysis for Seattle-Tacoma International Airport Master Plan Update improvements. Prepared by Parametrix for the Port of Seattle. Kirkland, Washington.
- Parametrix. 2000c. Wetland delineation report for Seattle-Tacoma International Airport Master Plan Update improvements. Prepared by Parametrix for the Port of Seattle. Kirkland, Washington.

- Parametrix. 2000d. Biological assessment for Seattle-Tacoma International Airport Master Plan Update improvements. Prepared by Parametrix for the Port of Seattle. Kirkland, Washington.
- Payne, N.F. and F.C. Bryant. 1992. Techniques for habitat management of uplands. [Biological Resource Management Series]. McGraw-Hill Publications, New York, New York.
- Pennak, R.W. 1989. Fresh-water invertebrates of the United States, 3rd ed. John Wiley & Sons, Inc., New York, New York.
- Pitt, R. and P. Bissonnette. 1984. Bellevue urban runoff program, summary report. City of Bellevue, Storm and Surface Water Utility. Bellevue, Washington.
- Platts, W.S., W.F. Megahan, and G.W. Minshall. 1983. Methods for evaluating stream, riparian, and biotic conditions. USDA Forest Service, Intermountain Research Station. (GTR-INT-138). Ogden, Utah.
- Port of Seattle. 1997. Final supplemental environmental impact statement for proposed master plan update development actions at Seattle-Tacoma International Airport. Prepared for the Port of Seattle. SeaTac, Washington.
- Port of Seattle. 1997a. Annual stormwater monitoring report for the period July 1, 1996 through May 1, 1997. Port of Seattle. Seattle, Washington.
- Port of Seattle. 1997b. Seattle-Tacoma International Airport stormwater pollution prevention plan (SWPPP). Port of Seattle. Seattle, Washington.
- Port of Seattle. 1997c. Stormwater receiving environment monitoring report for NPDES Permit No. WA-002465-1. Port of Seattle. Seattle, Washington.
- Port of Seattle. 1998a. Annual stormwater monitoring report for Seattle-Tacoma International Airport, final draft. Permit # WA-002465-1. Port of Seattle. Seattle, Washington.
- Port of Seattle. 1998b. Port of Seattle Position Paper: Off-airport mitigation of wetland wildlife habitat function. Port of Seattle. Seattle, Washington.
- U.S. Department of Agriculture (USDA). 2000. Wildlife Hazard Management Plan Seattle-Tacoma International Airport. Seattle, Washington.
- Puget Sound Estuary Program (PSEP). 1991. Evaluation of the atmospheric deposition of toxic contaminants to Puget Sound. U.S. EPA 910/9-91-027.
- Puget Sound Regional Council. 1994. Satellite remote sensing projects land cover and change detection. Seattle, Washington.
- Ralph, C.J. and J.M. Scott (eds.). 1981. Estimating numbers of terrestrial birds. Proceedings of an International Symposium held at Asilomar, California, October 26-31, 1980 [Studies in Avian Biology, No.6]. Cooper Ornithological Society. Lawrence, Kansas.

- Ramsey, F.L. and J.M. Scott. 1979. Estimating population densities from variable circular plot surveys. Pages 155-182. *In*: R.M. Cormack, G.P. Patil, and D.S. Robson, (eds.) Sampling biological populations. [Statistical Ecology Series, Vol 5. International Congress of Ecology] International Cooperative Publishing House, Fairland, Maryland.
- Reed, P.B. 1988. National list of plant species that occur in wetlands: Northwest Region (Region 9). U.S. Fish and Wildlife Service. [Biological Report 88(26.9)]. Washington, D.C.
- Reimold, R.J. 1994. Wetlands functions and values. *In*: Applied wetlands science and technology. Donald Kent, (ed). Lewis Publishers, Boca Raton, Florida. 436p.
- Reppert, R.T., W. Sitleo, E. Stakhiv, L. Messman, and C.D. Meyers. 1979. Wetlands values: concepts and methods for wetlands evaluation. Institute for Water Resources, U.S. Army Corps of Engineers. (Res. Rpt. 79-R1). Fort Bevoir, Virginia.
- Reynolds, R.T., J.M. Scott, and R.A. Nussbaum. 1980. A variable circular-plot method for estimating bird numbers. *Condor*, 82:309-313.
- Richey, J.S. 1982. Effects of urbanization on a lowland stream in western Washington. Ph.D. Dissertation, University of Washington. Seattle, Washington.
- Richter, K.O. and A.L. Azous. 1995. Amphibian occurrence and wetland characteristics in the Puget Sound basin. *Wetlands*, 15 (3): 305-312.
- SeaTac, City of. 1993. Wetlands and streams classifications in the City of SeaTac. Bmap folio. SeaTac, Washington.
- Seubert, J.L. 1977. Bird strike hazard to turbine powered aircraft. Pages 53-68 *In*: Proceedings of the third world conference on bird hazards to aircraft. Bird Strike Comm. Europe. Paris, France.
- Snyder, D.E., G.P. Philip, and R.F. Russell. 1973. Soil Survey of King County Area, Washington. United States Department of Agriculture, Soil Conservation Service. In cooperation with the Washington agricultural experiment station.
- Soloman, V.E.F. 1973. Birds and aircraft. *Biological Conservation*. 5:277-278.
- Solomon, C. and N. Sexton. 1994. Methods for evaluating wetland functions. Water Resource Program Technical Note WG-EV-2.2. U.S. Army Corps of Engineers, Waterways Experiment Station. Vicksburg, Mississippi.
- Steward, C.R. 1983. Salmonid populations in an urban stream environment. M.S. Thesis, University of Washington. Seattle, Washington.
- Taylor, B.L. 1993. The influence of wetland and watershed morphological characteristics on wetland hydrology and relationships to wetland vegetation communities. M.S. Thesis, University of Washington. Seattle, Washington.

- Tukwila, City of. 1997. Riverton Creek Stormwater Quality Management Plan. Water quality, stream habitat, and flood control. City of Tukwila, Washington. November 1997.
- U.S. Army Corps of Engineers (ACOE). 1982. Clarification of "normal circumstances" in the wetland definition. Regulatory Guidance Letter No. 82-2.
- U.S. Army Corps of Engineers (ACOE). 1986. Clarification of "normal circumstances" in wetland definition. Regulatory Guidance Letter No. 86-9. (33 CFR 323.2(c)).
- U.S. Army Corps of Engineers (ACOE). 1990. Clarification and Interpretation of the 1987 Manual. Regulatory Guidance Letter No. 90-7.
- U.S. Army Corps of Engineers (ACOE). 1992. Clarification and interpretation of the 1987 manual. 3-92 Memorandum.
- U.S. Army Corps of Engineers (ACOE). 1994. Washington regional guidance on the 1987 wetland delineation manual. 5-94 Public Notice.
- U.S. Army Corps of Engineers (ACOE). 1995. Mill Creek S.A.M.P. wetlands management plan (Draft #6 Submittal). Seattle, Washington.
- U.S. Army Corps of Engineers (ACOE). 1997. Mill Creek Basin, King County, Washington. Aquatic resources restoration plan, Draft 1. Seattle, Washington.
- U.S. Department of Agriculture, Natural Resource Conservation Service in cooperation with U.S. EPA, USFWS, ACOE, and North Carolina State University. Version 2.0. Field indicators of hydric soils in the United States.
- U.S. Department of Agriculture, Soil Conservation Service. 1973. Soil survey of King County area, Washington. United States Government Printing Office. Washington, D.C.
- U.S. Department of Agriculture, Soil Conservation Service. 1991. Hydric soils of the United States. U.S. Department of Agriculture, Soil Conservation Service. Miscellaneous Publication No. 1491.
- U.S. Environmental Protection Agency (U.S. EPA) and Army Corps of Engineers (ACOE). 1993. Memorandum to the field, Establishment and use of wetland mitigation banks in the Clean Water Act Section 404 regulatory program. August 23, 1993.
- U.S. Environmental Protection Agency (U.S. EPA). 1983. Results of the nationwide urban runoff program. (NTIS PB84-185552). Washington, D.C.
- U.S. Environmental Protection Agency (U.S. EPA). 1984. Guidelines for deriving numerical aquatic site-specific water quality criteria by modifying national criteria. (U.S. EPA-600/3-84-099). Duluth, Minnesota.
- U.S. Environmental Protection Agency (U.S. EPA). 1986. Quality criteria for water. Office of Water Regulation and Standards. (U.S. EPA 440/5-86-001). Washington, DC

- U.S. Environmental Protection Agency (U.S. EPA). 1991. Technical support document for water quality based toxics control. (U.S. EPA/505/2-90-001). Cincinnati, Ohio.
- U.S. Environmental Protection Agency (U.S. EPA). 1993. Hydrological simulation program—FORTRAN, Users manual for release 10. Environmental Research Laboratory, Office of Research and Development, U.S. EPA. Athens, Georgia.
- U.S. Environmental Protection Agency (U.S. EPA). 1994. Interim guidance on determination and use of water-effect ratios for metal. (U.S. EPA/823/b94/001). Washington, D.C.
- U.S. Fish and Wildlife Service (USFWS). 1987. National wetlands inventory, Des Moines, Washington Quadrangle.
- U.S. Geological Survey. 1995. 7.5 Minute topographic series, Des Moines, Washington Quadrangle. Revised 1995.
- U.S. Geological Survey. 1996. Washington surface-water data retrieval. Found on the world wide web at <http://h20.usgs.gov/sur/WA>.
- Washington State Department of Ecology (Ecology). 1990. Model wetlands protection ordinance. Olympia, Washington.
- Washington State Department of Ecology (Ecology). 1992. Stormwater management manual for the Puget Sound basin, the technical manual. Washington Department of Ecology. Olympia, Washington.
- Washington State Department of Ecology (Ecology). 1993. Washington state wetlands rating system. (Publication 93-74). Olympia, Washington.
- Washington State Department of Ecology (Ecology). 1994a. Guidelines for developing freshwater wetlands mitigation plans and proposals. Olympia, Washington.
- Washington State Department of Ecology (Ecology). 1994b. National pollutant discharge elimination system permit number WA-002465-1, issued February 20, 1998 by Washington Department of Ecology. Olympia, Washington.
- Washington State Department of Ecology (Ecology). 1995. Use of the 1987 U.S. Army Corps of Engineers wetlands delineation manual. 3-95 Public Notice.
- Washington State Department of Ecology (Ecology). 1996. An approach to developing methods to assess the performance of Washington's wetlands. [Publication 96-110]. Olympia, Washington.
- Washington State Department of Ecology (Ecology). 1997. Washington state wetlands identification and delineation manual. Ecology Publications #96-94. Olympia, Washington.

Washington State Department of Ecology (Ecology). 1998. Order #96-4-02325: Water quality certification/coastal zone consistency determination for Port of Seattle—master plan improvements project. Unpublished letter from Ecology to Port of Seattle. Seattle, Washington.

Williams, R.W., R. Laramie, and J.J. Ames. 1975. A catalog of Washington streams and salmon utilization. Volume I. Washington Department of Fisheries. Puget Sound. Seattle, Washington.

AR 048948

APPENDICES A THROUGH E

**DESIGN DRAWINGS
(UNDER SEPARATE COVER)**

AR 048949

APPENDIX F
RESTRICTIVE COVENANTS

AR 048950

DRAFT
10/30/00

RECORDED AT THE REQUEST OF
AND AFTER RECORDING RETURN TO:

DECLARATION OF RESTRICTIVE COVENANTS
(Miller Creek/Lora Lake/Vacca Farm Wetland and Floodplain Mitigation Area)

Grantor: Port of Seattle, a Washington municipal corporation

Grantees: Port of Seattle, a Washington municipal corporation

Legal Description: _____
Official legal description attached on Exhibit A.

Assessor's Tax Parcel ID#: _____

Reference # (If applicable): N/A

This Declaration of Restrictive Covenants (this "Declaration") is made as of this _____ day of _____, _____, by the Port of Seattle, a Washington municipal corporation (the "Port") as required by the Washington State Department of Ecology ("Ecology") Order number _____ and the Seattle District Office of the U.S. Army Corps of Engineers ("Corps") Section 404 Permit Number _____, each more particularly described in Recital C, below.

RECITALS

A. The Port is the owner of those certain real properties located in King County, Washington and described as follows: (i) the real property adjacent to or near Miller Creek (the "Miller Creek Mitigation Area"); (ii) the real property adjacent to or near Miller Creek, Lora Lake, and the former Vacca Farm (the "Miller Creek/Lora Lake/Vacca Farm Wetland and Floodplain Mitigation Area"); (iii) the real property adjacent to or near the Tyee Valley Golf Course property (the "Tyee Valley Golf Course Mitigation Area"); (iv) the real property comprising approximately 67-acres located in the City of Auburn (the "Auburn Wetland Mitigation Area"); (v) the real property adjacent to or near Des Moines Creek (the "Des Moines Creek Mitigation Area"); and (vi) the real property at and adjacent to the Tyee Detention Pond (the "Tyee Detention Pond Area") (collectively, the "Miller Creek Mitigation Area," the "Miller Creek/Lora Lake/Vacca Farm Wetland and Floodplain Mitigation Area," the "Tyee Valley Golf Course Mitigation Area," the "Des Moines Creek Mitigation Area," the "Tyee Detention Pond Area," and the "Auburn Wetland Mitigation Area" are referred to herein as the "Mitigation Sites"). This Declaration relates to the Miller Creek/Lora Lake/Vacca Farm Mitigation Area, which is legally described in Exhibit A attached hereto and by this reference incorporated herein.

B. In connection with the construction of a third runway and other improvements at Seattle-Tacoma International Airport, the Port proposed certain mitigation activities for the Mitigation Sites that include: stream riparian/buffer enhancements, stream baseflow augmentation, floodplain and wetland enhancement, and construction of replacement wetlands.

C. In order to comply with Ecology's Order # _____ ("Ecology's Order"), and the Corps Section 404 Permit # _____ ("Corps Permit"), for the Port's mitigation activities at the Mitigation Sites, the Port has executed this Declaration regarding the Miller Creek/Lora Lake/Vacca Farm Wetland and Floodplain Mitigation Area, and has executed similar Declarations for the other Mitigation Sites, to submit the Miller Creek/Lora Lake/Vacca Farm Wetland and Floodplain Mitigation Area to the covenants, conditions, and restrictions herein.

NOW, THEREFORE:

1. Declaration. The Port hereby declares that the Miller Creek/Lora Lake/Vacca Farm Wetland and Floodplain Mitigation Area (hereinafter, the "Mitigation Area") shall be subject to the covenants, conditions, and restrictions stated herein which shall be binding on all parties having any right, title, or interest in the Mitigation Area or any part thereof and shall inure to the benefit of each subsequent owner thereof.

2. **Purpose.** The purpose of this Declaration is to meet the requirements of the federal Clean Water Act and state water quality standards as set forth in Ecology's Order and the Corps Permit, and to restrict development and construction activities within the Mitigation Area.

3. **Restrictive Covenants.** The Mitigation Area shall be used as a floodplain, wetlands, flood storage areas, and/or riparian corridors, and no development activity including clearing, grading, filling, or the construction of any building, structure, or other improvement shall occur in the Mitigation Area, except for the following:

- a. Activities authorized in the Corps/Ecology-approved Natural Resource Mitigation Plan to construct and establish the mitigation. Existing uses in the Mitigation Area may continue until the uses are removed or halted during construction of the mitigation.
- b. Wildlife management control actions pursuant to and governed by the current Wildlife Hazard Management Plan or any subsequent version of the Plan adopted by the Port in cooperation with the U.S. Department of Agriculture's Wildlife Services Program and the Federal Aviation Administration pursuant to Title 14 of the Code of Federal Regulations (Section 139.337). Prior to the adoption of any subsequent version of the Plan, the Plan shall be submitted to the Corps and Ecology for review and comment regarding potential impacts on the Mitigation Area. If during review and comment, the Corps or Ecology identifies any impacts to the functions and values of the Mitigation Area, the Port shall within 60 days submit to the Corps and Ecology a conceptual plan that compensates for the identified impacts and, within 90 days following Corps and Ecology approval of the conceptual plan, submit for approval a final compensation plan.
- c. Monitoring, maintenance, and contingency actions pursuant to Ecology's Order and the Corps Permit, including but not limited to removal of exotic, non-native, invasive vegetation to satisfy the mitigation performance standards.
- d. Construction of stormwater drainage channels as authorized in writing by the Corps and Ecology, and maintenance of those channels.

- e. Installation of guy-wires and anchors (to support navigation light towers outside the Mitigation Area) and maintenance of the guy-wires and anchors.
- f. Continuation, including maintenance and reconstruction, of the existing underground sanitary sewer trunk line, owned and operated by the Southwest Suburban Sewer District or its successor; and partial relocation of this line as authorized in writing by the Corps and Ecology.
- g. Installation of water and air quality monitoring equipment as authorized in writing by the Corps and Ecology, and maintenance of the equipment.
- h. Continuation, including maintenance and reconstruction, of the existing electrical power line owned and operated by Seattle City Light or its successor.
- i. Vegetation height control to maintain FAA required approach slopes and radar coverage.
- j. Removal of trees that a certified arborist has recommended be removed to prevent a hazard to persons or property. The Port shall replant areas where trees are removed, as necessary to maintain consistency with the Corps/Ecology-approved Natural Resources Mitigation Plan.
- k. Other activities authorized in writing by the Corps and Ecology.

Following any activity in the Mitigation Area, as authorized above, the Port shall restore the Mitigation Area to the condition contemplated in the Corps/Ecology-approved Natural Resource Mitigation Plan (except for any authorized structure or use that will remain in the Mitigation Area).

4. Default; Remedies. Any violation of a covenant or condition in this Declaration shall be considered a violation of Ecology's Order and the Corps Permit, and this Declaration may be enforced pursuant to the terms of Ecology's Order and the Corps Permit.

5. Binding Effect. The Declaration shall run with the land and be binding upon the Port and its successors and assigns.

6. Captions. The captions and paragraph headings contained in this Declaration are for convenience and reference only and in no way define, describe, extend, or limit the scope or intent of this Declaration, nor the intent of any provision hereof.

7. Recording. This Declaration shall be recorded in the real property records of King County.

8. No Third Party Rights. Nothing in this Declaration, express or implied, is intended to confer upon any person, other than the Port and its successors and assigns any rights or remedies under or by reason of this Declaration; provided that this Declaration may be enforced by the Corps or Ecology as described herein.

9. Governing Law. This Declaration shall be governed by and construed in accordance with the laws of the state of Washington.

EXECUTED AND EFFECTIVE as of the date first written above.

PORT OF SEATTLE, a Washington municipal corporation

By: _____
Name: _____
Its: _____

STATE OF WASHINGTON)
) ss.
COUNTY OF _____)

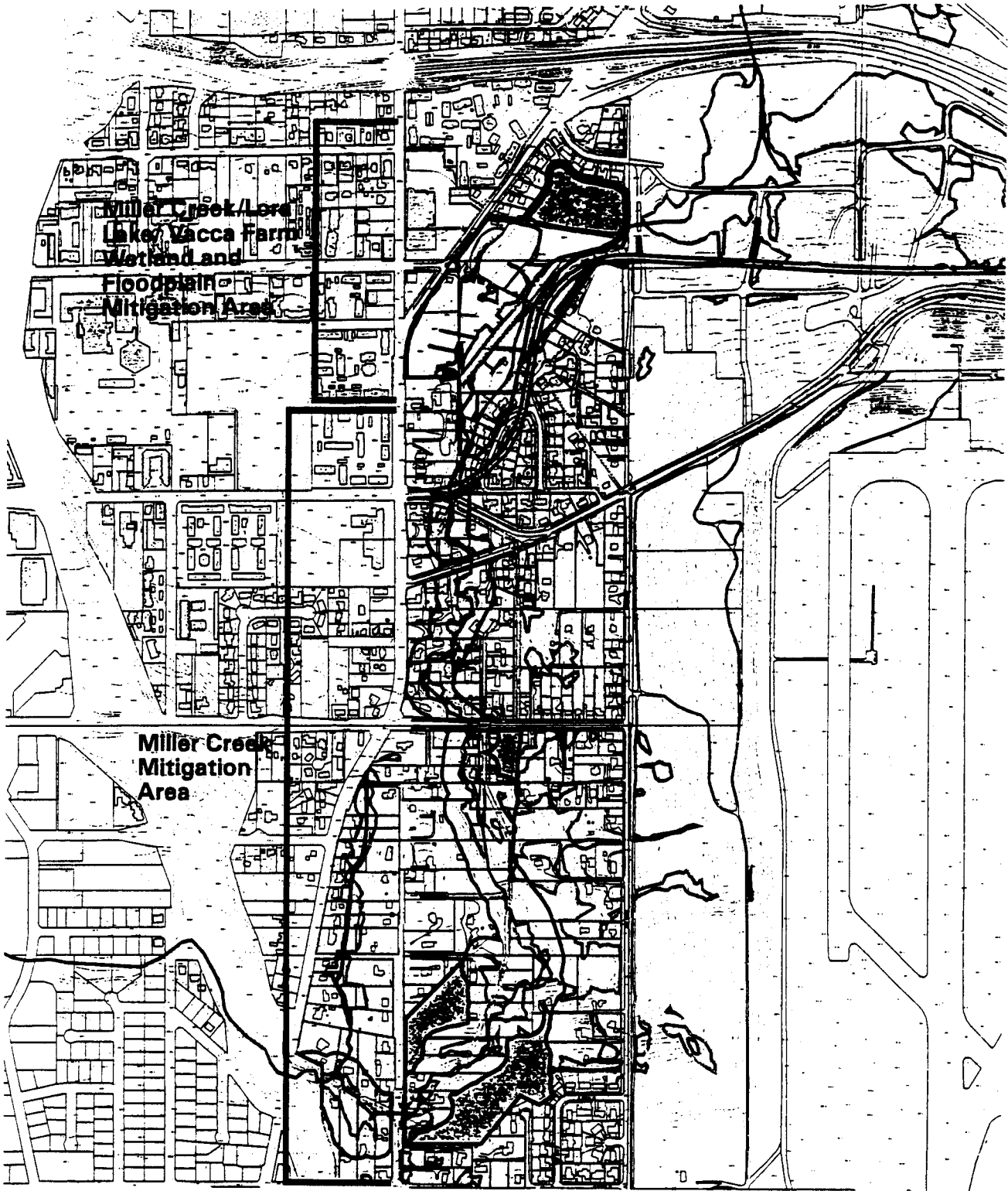
I certify that I know or have satisfactory evidence that _____ signed this instrument, on oath stated that he was authorized to execute the instrument and acknowledged it as the _____ of the Port of Seattle, a Washington municipal corporation, to be the free and voluntary act of such municipal corporation for the uses and purposes mentioned in the instrument.

Dated this _____ day of _____, _____.

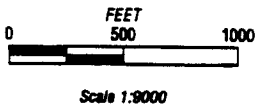
(Signature of Notary)




(Legibly Print or Stamp Name of Notary)




Notary public in and for the state of
Washington, residing at _____
My appointment expires: _____



Prepared by Parametrix, Inc. File: eee2a2/plotam/plotam11_millerbuf.aml creating p_0z11_millerbuf.gri Date: December 19, 2000



-  Surveyed wetland boundary
-  Restrictive Covenant Area
-  Buffer Averaging Area

-  Miller Creek
-  20' Sewer Line Easement
-  Contour Lines

Location of Miller Creek / Lora Lake / Vacca Farm Wetland and Floodplain Mitigation Area Restrictive Covenants

AR 048957

DRAFT
10/30/00

RECORDED AT THE REQUEST OF
AND AFTER RECORDING RETURN TO:

**DECLARATION OF RESTRICTIVE COVENANTS
(Miller Creek Mitigation Area)**

Grantor: Port of Seattle, a Washington municipal corporation

Grantees: Port of Seattle, a Washington municipal corporation

Legal Description: _____
Official legal description attached on Exhibit A.

Assessor's Tax Parcel ID#: _____

Reference # (If applicable): N/A

This Declaration of Restrictive Covenants (this "Declaration") is made as of this _____ day of _____, _____, by the Port of Seattle, a Washington municipal corporation (the "Port") as required by the Washington State Department of Ecology ("Ecology") Order number _____ and the Seattle District Office of the U.S. Army Corps of Engineers ("Corps") Section 404 Permit Number _____, each as more particularly described in Recital C, below.

RECITALS

A. The Port is the owner of those certain real properties located in King County, Washington and described as follows: (i) the real property adjacent to or near Miller Creek (the "Miller Creek Mitigation Area"); (ii) the real property adjacent to or near Miller Creek, Lora Lake, and the former Vacca Farm (the "Miller Creek/Lora Lake/Vacca Farm Wetland and Floodplain Mitigation Area"); (iii) the real property adjacent to or near the Tyee Valley Golf Course property (the "Tyee Valley Golf Course Mitigation Area"); (iv) the real property comprising approximately 67-acres located in the City of Auburn (the "Auburn Wetland Mitigation Area"); (v) the real property adjacent to or near Des Moines Creek (the "Des Moines Creek Mitigation Area"); and (vi) the real property at and adjacent to the Tyee Detention Pond (the "Tyee Detention Pond Area") (collectively, the "Miller Creek Mitigation Area," the "Miller Creek/Lora Lake/Vacca Farm Wetland and Floodplain Mitigation Area," the "Tyee Valley Golf Course Mitigation Area," the "Des Moines Creek Mitigation Area," the "Tyee Detention Pond Area," and the "Auburn Wetland Mitigation Area" are referred to herein as the "Mitigation Sites"). This Declaration relates to the Miller Creek Mitigation Area, which is legally described in Exhibit A attached hereto and by this reference incorporated herein.

B. In connection with the construction of a third runway and other improvements at Seattle-Tacoma International Airport, the Port proposed certain mitigation activities for the Mitigation Sites that include: stream riparian/buffer enhancements, stream baseflow augmentation, floodplain and wetland enhancement, and construction of replacement wetlands.

C. In order to comply with Ecology's Order # _____ ("Ecology's Order"), and the Corps Section 404 Permit # _____ ("Corps Permit"), for the Port's mitigation activities at the Mitigation Sites, the Port has executed this Declaration regarding the Miller Creek Mitigation Area, and has executed similar Declarations for the other Mitigation Sites, to submit the Miller Creek Mitigation Area to the covenants, conditions, and restrictions herein.

NOW, THEREFORE:

1. Declaration. The Port hereby declares that the Miller Creek Mitigation Area (hereinafter, the "Mitigation Area") shall be subject to the covenants, conditions, and restrictions stated herein which shall be binding on all parties having any right, title, or interest in the Mitigation Area or any part thereof and shall inure to the benefit of each subsequent owner thereof.

2. **Purpose.** The purpose of this Declaration is to meet the requirements of the federal Clean Water Act and state water quality standards as set forth in Ecology's Order and the Corps Permit, and to restrict development and construction activities within the Mitigation Area.
3. **Restrictive Covenants.** The Mitigation Area shall be used as a natural vegetative buffer, and no development activity including clearing, grading, filling, or the construction of any building, structure, or other improvement shall occur in the Mitigation Area, except for the following:
 - a. Activities authorized in the Corps/Ecology-approved Natural Resource Mitigation Plan to construct and establish the mitigation. Existing uses in the Mitigation Area may continue until the uses are removed or halted during construction of the mitigation.
 - b. Wildlife management control actions pursuant to and governed by the current Wildlife Hazard Management Plan or any subsequent version of the Plan adopted by the Port in cooperation with the U.S. Department of Agriculture's Wildlife Services Program and the Federal Aviation Administration pursuant to Title 14 of the Code of Federal Regulations (Section 139.337). Prior to the adoption of any subsequent version of the Plan, the Plan shall be submitted to the Corps and Ecology for review and comment regarding potential impacts on the Mitigation Area. If during review and comment, the Corps or Ecology identifies any impacts to the functions and values of the Mitigation Area, the Port shall within 60 days submit to the Corps and Ecology a conceptual plan that compensates for the identified impacts and, within 90 days following Corps and Ecology approval of the conceptual plan, submit for approval a final compensation plan.
 - c. Monitoring, maintenance, and contingency actions pursuant to Ecology's Order and the Corps Permit, including but not limited to removal of exotic, non-native, invasive vegetation to satisfy the mitigation performance standards.
 - d. Construction of stormwater drainage channels as authorized in writing by the Corps and Ecology, and maintenance of those channels.
 - e. Continuation, including maintenance and reconstruction, of the existing underground sanitary sewer trunk line, owned and operated by the Southwest Suburban Sewer District or its successor; and partial relocation of this line as authorized in writing by the Corps and Ecology.

- f. Installation of water and air quality monitoring equipment as authorized in writing by the Corps and Ecology, and maintenance of the equipment.
- g. Vegetation height control to maintain FAA required approach slopes and radar coverage.
- h. Removal of trees that a certified arborist has recommended be removed to prevent a hazard to persons or property. The Port shall replant areas where trees are removed, as necessary to maintain consistency with the Corps/Ecology-approved Natural Resources Mitigation Plan.
- i. Other activities authorized in writing by the Corps and Ecology.

Following any activity in the Mitigation Area, as authorized above, the Port shall restore the Mitigation Area to the condition contemplated in the Corps/Ecology-approved Natural Resource Mitigation Plan (except for any authorized structure or use that will remain in the Mitigation Area).

- 4. Default: Remedies. Any violation of a covenant or condition in this Declaration shall be considered a violation of Ecology's Order and the Corps Permit, and this Declaration may be enforced pursuant to the terms of Ecology's Order and the Corps Permit.
- 5. Binding Effect. The Declaration shall run with the land and be binding upon the Port and its successors and assigns.
- 6. Captions. The captions and paragraph headings contained in this Declaration are for convenience and reference only and in no way define, describe, extend, or limit the scope or intent of this Declaration, nor the intent of any provision hereof.
- 7. Recording. This Declaration shall be recorded in the real property records of King County.
- 8. No Third Party Rights. Nothing in this Declaration, express or implied, is intended to confer upon any person, other than the Port and its successors and assigns any rights or remedies under or by reason of this Declaration; provided that this Declaration may be enforced by the Corps or Ecology as described herein.
- 9. Governing Law. This Declaration shall be governed by and construed in accordance with the laws of the state of Washington.

EXECUTED AND EFFECTIVE as of the date first written above.

PORT OF SEATTLE, a Washington municipal
corporation

By: _____
Name: _____
Its: _____

STATE OF WASHINGTON)
) ss.
COUNTY OF _____)

I certify that I know or have satisfactory evidence that _____ signed this instrument, on oath stated that he was authorized to execute the instrument and acknowledged it as the _____ of the Port of Seattle, a Washington municipal corporation, to be the free and voluntary act of such municipal corporation for the uses and purposes mentioned in the instrument.

Dated this _____ day of _____, _____.

(Signature of Notary)

(Legibly Print or Stamp Name of Notary)

Notary public in and for the state of
Washington, residing at _____
My appointment expires: _____

DRAFT
10/30/00

RECORDED AT THE REQUEST OF
AND AFTER RECORDING RETURN TO:

**DECLARATION OF RESTRICTIVE COVENANTS
(Tye Valley Golf Course Mitigation Area)**

Grantor: Port of Seattle, a Washington municipal corporation

Grantees: Port of Seattle, a Washington municipal corporation

Legal Description: _____
Official legal description attached on Exhibit A.

Assessor's Tax Parcel ID#: _____

Reference # (If applicable): N/A

This Declaration of Restrictive Covenants (this "Declaration") is made as of this _____ day of _____, _____, by the Port of Seattle, a Washington municipal corporation (the "Port") as required by the Washington State Department of Ecology ("Ecology") Order number _____ and the Seattle District Office of the U.S. Army Corps of Engineers ("Corps) Section 404 Permit Number _____, each as more particularly described in Recital C, below.

RECITALS

A. The Port is the owner of those certain real properties located in King County, Washington and described as follows: (i) the real property adjacent to or near Miller Creek (the "Miller Creek Mitigation Area"); (ii) the real property adjacent to or near Miller Creek, Lora Lake, and the former Vacca Farm (the "Miller Creek/Lora Lake/Vacca Farm Wetland and Floodplain Mitigation Area"); (iii) the real property adjacent to or near the Tyee Valley Golf Course property (the "Tyee Valley Golf Course Mitigation Area"); (iv) the real property comprising approximately 67-acres located in the City of Auburn (the "Auburn Wetland Mitigation Area"); (v) the real property adjacent to or near Des Moines Creek (the "Des Moines Creek Mitigation Area"); and (vi) the real property at and adjacent to the Tyee Detention Pond (the "Tyee Detention Pond Area") (collectively, the "Miller Creek Mitigation Area," the "Miller Creek/Lora Lake/Vacca Farm Wetland and Floodplain Mitigation Area," the "Tyee Valley Golf Course Mitigation Area," the "Des Moines Creek Mitigation Area," the "Tyee Detention Pond Area," and the "Auburn Wetland Mitigation Area" are referred to herein as the "Mitigation Sites"). This Declaration relates to the Tyee Valley Golf Course Mitigation Area, which is legally described in Exhibit A attached hereto and by this reference incorporated herein.

B. In connection with the construction of a third runway and other improvements at Seattle-Tacoma International Airport, the Port proposed certain mitigation activities for the Mitigation Sites that include: stream riparian/buffer enhancements, stream baseflow augmentation, floodplain and wetland enhancement, and construction of replacement wetlands.

C. In order to comply with Ecology's Order # _____ ("Ecology's Order"), and the Corps Section 404 Permit # _____ ("Corps Permit"), for the Port's mitigation activities at the Mitigation Sites, the Port has executed this Declaration regarding the Tyee Valley Golf Course Mitigation Area, and has executed similar Declarations for the other Mitigation Sites, to submit the Tyee Valley Golf Course Mitigation Area to the covenants, conditions, and restrictions herein.

NOW, THEREFORE:

1. Declaration. The Port hereby declares that the Tyee Valley Golf Course Mitigation Area (hereinafter, the "Mitigation Area") shall be subject to the covenants, conditions, and restrictions stated herein which shall be binding on all parties having any right, title, or interest in the Mitigation Area or any part thereof and shall inure to the benefit of each subsequent owner thereof.

2. Purpose. The purpose of this Declaration is to meet the requirements of the federal Clean Water Act and state water quality standards as set forth in Ecology's Order and the Corps Permit, and to restrict development and construction activities within the Mitigation Area.

3. Restrictive Covenants. The Mitigation Area shall be used as a natural wetland area, and no development activity including clearing, grading, filling, or the construction of any building, structure, or other improvement shall occur in the Mitigation Area, except for the following:

- a. Activities authorized in the Corps/Ecology-approved Natural Resource Mitigation Plan to construct and establish the mitigation. Existing uses in the Mitigation Area may continue until the uses are removed or halted during construction of the mitigation.
- b. Wildlife management control actions pursuant to and governed by the current Wildlife Hazard Management Plan or any subsequent version of the Plan adopted by the Port in cooperation with the U.S. Department of Agriculture's Wildlife Services Program and the Federal Aviation Administration pursuant to Title 14 of the Code of Federal Regulations (Section 139.337). Prior to the adoption of any subsequent version of the Plan, the Plan shall be submitted to the Corps and Ecology for review and comment regarding potential impacts on the Mitigation Area. If during review and comment, the Corps or Ecology identifies any impacts to the functions and values of the Mitigation Area, the Port shall within 60 days submit to the Corps and Ecology a conceptual plan that compensates for the identified impacts and, within 90 days following Corps and Ecology approval of the conceptual plan, submit for approval a final compensation plan.
- c. Monitoring, maintenance, and contingency actions pursuant to Ecology's Order and the Corps Permit, including but not limited to removal of exotic, non-native, invasive vegetation to satisfy the mitigation performance standards.
- d. Construction of stormwater drainage channels as authorized in writing by the Corps and Ecology and maintenance of those channels.
- e. Installation of water and air quality monitoring equipment as authorized in writing by the Corps and Ecology, and maintenance of the equipment.

- f. Vegetation height control to maintain FAA required approach slopes and radar coverage.
- g. Removal of trees that a certified arborist has recommended be removed to prevent a hazard to persons or property. The Port shall replant areas where trees are removed, as necessary to maintain consistency with the Corps/Ecology-approved Natural Resources Mitigation Plan.
- h. Other activities authorized in writing by the Corps and Ecology.

Following any activity in the Mitigation Area, as authorized above, the Port shall restore the Mitigation Area to the condition contemplated in the Corps/Ecology-approved Natural Resource Mitigation Plan (except for any authorized structure or use that will remain in the Mitigation Area).

4. Default: Remedies. Any violation of a covenant or condition in this Declaration shall be considered a violation of Ecology's Order and the Corps Permit, and this Declaration may be enforced pursuant to the terms of Ecology's Order and the Corps Permit.

5. Binding Effect. The Declaration shall run with the land and be binding upon the Port and its successors and assigns.

6. Captions. The captions and paragraph headings contained in this Declaration are for convenience and reference only and in no way define, describe, extend, or limit the scope or intent of this Declaration, nor the intent of any provision hereof.

7. Recording. This Declaration shall be recorded in the real property records of King County.

8. No Third Party Rights. Nothing in this Declaration, express or implied, is intended to confer upon any person, other than the Port and its successors and assigns any rights or remedies under or by reason of this Declaration; provided that this Declaration may be enforced by the Corps or Ecology as described herein.

9. Governing Law. This Declaration shall be governed by and construed in accordance with the laws of the state of Washington.

EXECUTED AND EFFECTIVE as of the date first written above.

PORT OF SEATTLE, a Washington municipal
corporation

By: _____
Name: _____
Its: _____

STATE OF WASHINGTON)
) ss.
COUNTY OF _____)

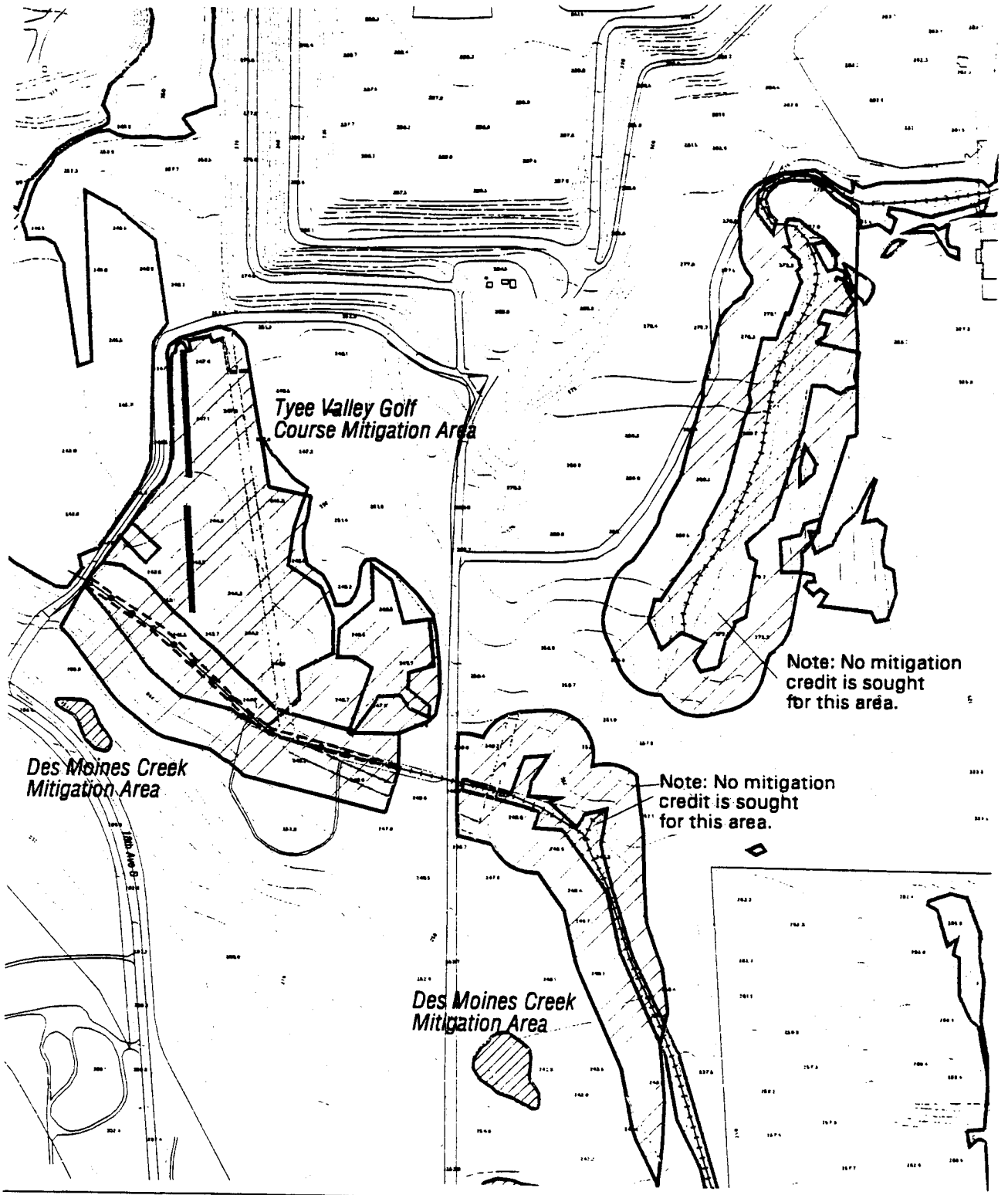
I certify that I know or have satisfactory evidence that _____
signed this instrument, on oath stated that he was authorized to execute the instrument and
acknowledged it as the _____ of the Port of Seattle, a Washington
municipal corporation, to be the free and voluntary act of such municipal corporation for the
uses and purposes mentioned in the instrument.

Dated this _____ day of _____, _____.

(Signature of Notary)

(Legibly Print or Stamp Name of Notary)

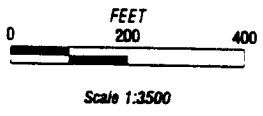
Notary public in and for the state of
Washington, residing at _____
My appointment expires: _____



Note: No mitigation credit is sought for this area.

Note: No mitigation credit is sought for this area.

Prepared by Parametric, Inc. File: s25ac2/p_6x11tyee_site.smi creating p6x11tyee_sde.gra Date: December 11, 2000



- | | | | |
|-------|----------------------------|---|-------------------------------------|
| — | Covenant Boundary | — | Des Moines Creek (est.) |
| - - - | Sewer Line Easement | ▭ | Surveyed Wetland Boundary |
| — | Des Moines Creek (svy.) | ▨ | Other Wetlands Outside Project Area |
| - - - | Des Moines Creek (culvert) | | |
| - - - | Surveyed OHWM | | |
| - - - | Des Moines Creek | | |

Restrictive Covenant at the Tyee Golf Course Mitigation Area

AR 048970

DRAFT
10/30/00

RECORDED AT THE REQUEST OF
AND AFTER RECORDING RETURN TO:

**DECLARATION OF RESTRICTIVE COVENANTS
(Des Moines Creek Mitigation Area)**

Grantor: Port of Seattle, a Washington municipal corporation

Grantees: Port of Seattle, a Washington municipal corporation

Legal Description: _____
Official legal description attached on Exhibit A.

Assessor's Tax Parcel ID#: _____

Reference # (If applicable): N/A

This Declaration of Restrictive Covenants (this "Declaration") is made as of this _____ day of _____, _____, by the Port of Seattle, a Washington municipal corporation (the "Port") as required by the Washington State Department of Ecology ("Ecology") Order number _____ and the Seattle District Office of the U.S. Army Corps of Engineers ("Corps") Section 404 Permit Number _____, each as more particularly described in Recital C, below

50200745.03
Des Moines Creek Mitigation Area

RECITALS

A. The Port is the owner of those certain real properties located in King County, Washington and described as follows: (i) the real property adjacent to or near Miller Creek (the "Miller Creek Mitigation Area"); (ii) the real property adjacent to or near Miller Creek, Lora Lake, and the former Vacca Farm (the "Miller Creek/Lora Lake/Vacca Farm Wetland and Floodplain Mitigation Area"); (iii) the real property adjacent to or near the Tyee Valley Golf Course property (the "Tyee Valley Golf Course Mitigation Area"); (iv) the real property comprising approximately 67-acres located in the City of Auburn (the "Auburn Wetland Mitigation Area"); (v) the real property adjacent to or near Des Moines Creek (the "Des Moines Creek Mitigation Area"); and (vi) the real property at and adjacent to the Tyee Detention Pond (the "Tyee Detention Pond Area") (collectively, the "Miller Creek Mitigation Area," the "Miller Creek/Lora Lake/Vacca Farm Wetland and Floodplain Mitigation Area," the "Tyee Valley Golf Course Mitigation Area," the "Des Moines Creek Mitigation Area," the "Tyee Detention Pond Area," and the "Auburn Wetland Mitigation Area" are referred to herein as the "Mitigation Sites"). This Declaration relates to the Des Moines Creek Mitigation Area, which is legally described in Exhibit A attached hereto and by this reference incorporated herein.

B. In connection with the construction of a third runway and other improvements at Seattle-Tacoma International Airport, the Port proposed certain mitigation activities for the Mitigation Sites that include: stream riparian/buffer enhancements, stream baseflow augmentation, floodplain and wetland enhancement, and construction of replacement wetlands.

C. In order to comply with Ecology's Order # _____ ("Ecology's Order"), and the Corps Section 404 Permit # _____ ("Corps Permit"), for the Port's mitigation activities at the Mitigation Sites, the Port has executed this Declaration regarding the Des Moines Creek Mitigation Area, and has executed similar Declarations for the other Mitigation Sites, to submit the Des Moines Creek Mitigation Area to the covenants, conditions, and restrictions herein.

NOW, THEREFORE:

1. Declaration. The Port hereby declares that the Des Moines Creek Mitigation Area (hereinafter the "Mitigation Area") shall be subject to the covenants, conditions, and restrictions stated herein which shall be binding on all parties having any right, title, or interest in the Mitigation Area or any part thereof and shall inure to the benefit of each subsequent owner thereof.

2. Purpose. The purpose of this Declaration is to meet the requirements of the federal Clean Water Act and state water quality standards as set forth in Ecology's Order and the Corps Permit, and to restrict development and construction activities within the Mitigation Area.

3. Restrictive Covenants. The Mitigation Area shall be a setback area adjacent to the creek, and no development activity including clearing, grading, filling, or the construction of any building, structure, or other improvement shall occur in the Mitigation Area, except for the following:

- a. Activities authorized in the Corps/Ecology-approved Natural Resource Mitigation Plan.
- b. Wildlife management control actions pursuant to and governed by the current Wildlife Hazard Management Plan or any subsequent version of the Plan adopted by the Port in cooperation with the U.S. Department of Agriculture's Wildlife Services Program and the Federal Aviation Administration pursuant to Title 14 of the Code of Federal Regulations (Section 139.337). Prior to the adoption of any subsequent version of the Plan, the Plan shall be submitted to the Corps and Ecology for review and comment regarding potential impacts on the Mitigation Area. If during review and comment, the Corps or Ecology identifies any impacts to the functions and values of the Mitigation Area, the Port shall within 60 days submit to the Corps and Ecology a conceptual plan that compensates for the identified impacts and, within 90 days following Corps and Ecology approval of the conceptual plan, submit for approval a final compensation plan.
- c. Monitoring, maintenance, and contingency actions pursuant to Ecology's Order and the Corps Permit.
- d. Construction of stormwater drainage channels as authorized in writing by the Corps and Ecology, and maintenance of those channels.
- e. Installation of water and air quality monitoring equipment as authorized in writing by the Corps and Ecology, and maintenance of the equipment.
- f. Vegetation height control to maintain FAA required approach slopes and radar coverage.

- g. Removal of trees that a certified arborist has recommended be removed to prevent a hazard to persons or property. The Port shall replant areas where trees are removed, as necessary to maintain consistency with the Corps/Ecology-approved Natural Resources Mitigation Plan.
- h. Continuation, including maintenance and reconstruction, of the existing underground sewer line owned and operated by the Port.
- i. Construction of a water supply pipeline and associated facilities for Des Moines Creek flow augmentation as authorized in writing by the Corps and Ecology, and maintenance of the pipeline and facilities.
- j. Activities to implement the Des Moines Creek Basin Plan as authorized in writing by the Corps and Ecology.
- k. Construction of a new roadway to the airport (known as "South Access") as authorized in writing by the Corps and Ecology, and maintenance of the roadway.
- l. Other activities authorized in writing by the Corps and Ecology.

Following any activity in the Mitigation Area, as authorized above, the Port shall restore the Mitigation Area to the condition contemplated in the Corps/Ecology-approved Natural Resource Mitigation Plan (except for any authorized structure or use that will remain in the Mitigation Area).

4. Default; Remedies. Any violation of a covenant or condition in this Declaration shall be considered a violation of Ecology's Order and the Corps Permit, and this Declaration may be enforced pursuant to the terms of Ecology's Order and the Corps Permit.

5. Binding Effect. The Declaration shall run with the land and be binding upon the Port and its successors and assigns.

6. Captions. The captions and paragraph headings contained in this Declaration are for convenience and reference only and in no way define, describe, extend, or limit the scope or intent of this Declaration, nor the intent of any provision hereof.

7. Recording. This Declaration shall be recorded in the real property records of King County.

8. No Third Party Rights. Nothing in this Declaration, express or implied, is intended to confer upon any person, other than the Port and its successors and assigns any rights or remedies under or by reason of this Declaration; provided that this Declaration may be enforced by the Corps or Ecology as described herein.

9. Governing Law. This Declaration shall be governed by and construed in accordance with the laws of the state of Washington.

EXECUTED AND EFFECTIVE as of the date first written above.

PORT OF SEATTLE, a Washington municipal corporation

By: _____
Name: _____
Its: _____

STATE OF WASHINGTON)
) ss.
COUNTY OF _____)

I certify that I know or have satisfactory evidence that _____ signed this instrument, on oath stated that he was authorized to execute the instrument and acknowledged it as the _____ of the Port of Seattle, a Washington municipal corporation, to be the free and voluntary act of such municipal corporation for the uses and purposes mentioned in the instrument.

Dated this _____ day of _____, _____.

(Signature of Notary)

(Legibly Print or Stamp Name of Notary)

Notary public in and for the state of
Washington, residing at _____
My appointment expires: _____

DRAFT
10/30/00

RECORDED AT THE REQUEST OF
AND AFTER RECORDING RETURN TO:

**DECLARATION OF RESTRICTIVE COVENANTS
(Tyee Detention Pond Area)**

Grantor: Port of Seattle, a Washington municipal corporation

Grantees: Port of Seattle, a Washington municipal corporation

Legal Description: _____
Official legal description attached on Exhibit A.

Assessor's Tax Parcel ID#: _____

Reference # (If applicable): N/A

This Declaration of Restrictive Covenants (this "Declaration") is made as of this _____ day of _____, _____, by the Port of Seattle, a Washington municipal corporation (the "Port") as required by the Washington State Department of Ecology ("Ecology") Order Number _____ and the Seattle District Office of the U.S. Army Corps of Engineers ("Corps") Section 404 Permit Number _____, each as more particularly described in Recital C, below

50210850.02
Tyee Detention Pond Area

RECITALS

A. The Port is the owner of those certain real properties located in King County, Washington and described as follows: (i) the real property adjacent to or near Miller Creek (the "Miller Creek Mitigation Area"); (ii) the real property adjacent to or near Miller Creek, Lora Lake, and the former Vacca Farm (the "Miller Creek/Lora Lake/Vacca Farm Wetland and Floodplain Mitigation Area"); (iii) the real property adjacent to or near the Tyee Valley Golf Course property (the "Tyee Valley Golf Course Mitigation Area"); (iv) the real property comprising approximately 67-acres located in the City of Auburn (the "Auburn Wetland Mitigation Area"); (v) the real property adjacent to or near Des Moines Creek (the "Des Moines Creek Mitigation Area"); and (vi) the real property at and adjacent to the Tyee Detention Pond (the "Tyee Detention Pond Area") (collectively, the "Miller Creek Mitigation Area," the "Miller Creek/Lora Lake/Vacca Farm Wetland and Floodplain Mitigation Area," the "Tyee Valley Golf Course Mitigation Area," the "Des Moines Creek Mitigation Area," the "Tyee Detention Pond Area," and the "Auburn Wetland Mitigation Area" are referred to herein as the "Mitigation Sites"). This Declaration relates to the Tyee Detention Pond Area, which is legally described in Exhibit A attached hereto and by this reference incorporated herein.

B. In connection with the construction of a third runway and other improvements at Seattle-Tacoma International Airport, the Port proposed certain mitigation activities for the Mitigation Sites that include: stream riparian/buffer enhancements, stream baseflow augmentation, floodplain and wetland enhancement, and construction of replacement wetlands.

C. In order to comply with Ecology's Order # _____ ("Ecology's Order"), and the Corps Section 404 Permit # _____ ("Corps Permit"), for the Port's mitigation activities at the Mitigation Sites, the Port has executed this Declaration regarding the Tyee Detention Pond Area, and has executed similar Declarations for the other Mitigation Sites, to submit the Tyee Detention Pond Area to the covenants, conditions, and restrictions herein.

NOW, THEREFORE:

1. Declaration. The Port hereby declares that the Tyee Detention Pond Area shall be subject to the covenants, conditions, and restrictions stated herein which shall be binding on all parties having any right, title, or interest in the Tyee Detention Pond Area or any part thereof and shall inure to the benefit of each subsequent owner thereof.

2. Purpose. The purpose of this Declaration is to meet the requirements of the federal Clean Water Act and state water quality standards as set forth in Ecology's Order

and the Corps Permit, and to restrict development and construction activities within the Tyee Detention Pond Area.

3. Restrictive Covenants. The Tyee Detention Pond Area shall be a stormwater detention pond, spill control facility, and adjacent buffer. No development activity including clearing, grading, filling, or the construction of any building, structure, or other improvement shall occur in the Tyee Detention Pond Area, except for the following:

- a. Activities authorized in the Corps/Ecology-approved Natural Resource Mitigation Plan.
- b. Wildlife management control actions pursuant to and governed by the current Wildlife Hazard Management Plan or any subsequent version of the Plan adopted by the Port in cooperation with the U.S. Department of Agriculture's Wildlife Services Program and the Federal Aviation Administration pursuant to Title 14 of the Code of Federal Regulations (Section 139.337). Prior to the adoption of any subsequent version of the Plan, the Plan shall be submitted to the Corps and Ecology for review and comment regarding potential impacts on the Tyee Detention Pond Area. If during review and comment, the Corps or Ecology identifies any impacts to the functions and values of the Tyee Detention Pond Area, the Port shall within 60 days submit to the Corps and Ecology a conceptual plan that compensates for the identified impacts and, within 90 days following Corps and Ecology approval of the conceptual plan, submit for approval a final compensation plan.
- c. Monitoring, maintenance, and contingency actions pursuant to Ecology's Order and the Corps Permit.
- d. Construction of stormwater drainage channels as authorized in writing by the Corps and Ecology, and maintenance of those channels.
- e. Installation of water and air quality monitoring equipment as authorized in writing by the Corps and Ecology, and maintenance of the equipment.
- f. Vegetation height control to maintain FAA required approach slopes and radar coverage.
- g. Removal of trees that a certified arborist has recommended be removed to prevent a hazard to persons or property. The Port shall replant areas

where trees are removed, as necessary to maintain consistency with the Corps/Ecology-approved Natural Resources Mitigation Plan.

- h. Construction of a water supply pipeline and associated facilities for Des Moines Creek flow augmentation as authorized in writing by the Corps and Ecology, and maintenance of the pipeline and facilities.
- i. Activities to implement the Des Moines Creek Basin Plan as authorized in writing by the Corps and Ecology.
- j. Activities related to the operation, maintenance, and periodic reconstruction/replacement of a stormwater detention pond and hazardous material spill control facility, including but not limited to mowing, vegetation clearing, animal control, maintenance of equipment such as sensors and outlet controls, and soil remediation.
- k. Construction of a new roadway to the airport (known as "South Access") as authorized in writing by the Corps and Ecology, and maintenance of the roadway.
- l. Other activities authorized in writing by the Corps and Ecology.

Following any activity in the Tyee Detention Pond Area, as authorized above, the Port shall restore the Tyee Detention Pond Area to the condition contemplated in the Corps/Ecology-approved Natural Resource Mitigation Plan (except for any authorized structure or use that will remain in the Tyee Detention Pond Area).

4. Default: Remedies. Any violation of a covenant or condition in this Declaration shall be considered a violation of Ecology's Order and the Corps Permit, and this Declaration may be enforced pursuant to the terms of Ecology's Order and the Corps Permit.

5. Binding Effect. The Declaration shall run with the land and be binding upon the Port and its successors and assigns.

6. Captions. The captions and paragraph headings contained in this Declaration are for convenience and reference only and in no way define, describe, extend, or limit the scope or intent of this Declaration, nor the intent of any provision hereof.

7. Recording. This Declaration shall be recorded in the real property records of King County.

8. No Third Party Rights. Nothing in this Declaration, express or implied, is intended to confer upon any person, other than the Port and its successors and assigns any rights or remedies under or by reason of this Declaration; provided that this Declaration may be enforced by the Corps or Ecology as described herein.

9. Governing Law. This Declaration shall be governed by and construed in accordance with the laws of the state of Washington.

EXECUTED AND EFFECTIVE as of the date first written above.

PORT OF SEATTLE, a Washington municipal corporation

By: _____
Name: _____
Its: _____

STATE OF WASHINGTON)
) ss.
COUNTY OF _____)

I certify that I know or have satisfactory evidence that _____
signed this instrument, on oath stated that he was authorized to execute the instrument and
acknowledged it as the _____ of the Port of Seattle, a Washington
municipal corporation, to be the free and voluntary act of such municipal corporation for the
uses and purposes mentioned in the instrument.

Dated this _____ day of _____, _____.

(Signature of Notary)

(Legibly Print or Stamp Name of Notary)

Notary public in and for the state of
Washington, residing at _____
My appointment expires: _____

DRAFT
10/30/00

RECORDED AT THE REQUEST OF
AND AFTER RECORDING RETURN TO:

DECLARATION OF RESTRICTIVE COVENANTS
(Auburn Wetland Mitigation Area)

Grantor: Port of Seattle, a Washington municipal corporation

Grantees: Port of Seattle, a Washington municipal corporation

Legal Description: _____
Official legal description attached on Exhibit A.

Assessor's Tax Parcel ID#: _____

Reference # (If applicable): N/A

This Declaration of Restrictive Covenants (this "Declaration") is made as of this _____ day of _____, _____, by the Port of Seattle, a Washington municipal corporation (the "Port") as required by the Washington State Department of Ecology ("Ecology") Order number _____ and the Seattle District Office of the U.S. Army Corps of Engineers ("Corps") Section 404 Permit Number _____, each as more particularly described in Recital C, below.

RECITALS

A. The Port is the owner of those certain real properties located in King County, Washington and described as follows: (i) the real property adjacent to or near Miller Creek (the "Miller Creek Mitigation Area"); (ii) the real property adjacent to or near Miller Creek, Lora Lake, and the former Vacca Farm (the "Miller Creek/Lora Lake/Vacca Farm Wetland and Floodplain Mitigation Area"); (iii) the real property adjacent to or near the Tyee Valley Golf Course property (the "Tyee Valley Golf Course Mitigation Area"); (iv) the real property comprising approximately 67-acres located in the City of Auburn (the "Auburn Wetland Mitigation Area"); (v) the real property adjacent to or near Des Moines Creek (the "Des Moines Creek Mitigation Area"); and (vi) the real property at and adjacent to the Tyee Detention Pond (the "Tyee Detention Pond Area") (collectively, the "Miller Creek Mitigation Area," the "Miller Creek/Lora Lake/Vacca Farm Wetland and Floodplain Mitigation Area," the "Tyee Valley Golf Course Mitigation Area," the "Des Moines Creek Mitigation Area," the "Tyee Detention Pond Area," and the "Auburn Wetland Mitigation Area" are referred to herein as the "Mitigation Sites"). This Declaration relates to the Auburn Wetland Mitigation Area, which is legally described in Exhibit A attached hereto and by this reference incorporated herein.

B. In connection with the construction of a third runway and other improvements at Seattle-Tacoma International Airport, the Port proposed certain mitigation activities for the Mitigation Sites that include: stream riparian/buffer enhancements, stream baseflow augmentation, floodplain and wetland enhancement, and construction of replacement wetlands.

C. In order to comply with Ecology's Order # _____ ("Ecology's Order"), and the Corps Section 404 Permit # _____ ("Corps Permit"), for the Port's mitigation activities at the Mitigation Sites, the Port has executed this Declaration regarding the Auburn Wetland Mitigation Area, and has executed similar Declarations for the other Mitigation Sites, to submit the Auburn Wetland Mitigation Area to the covenants, conditions, and restrictions herein.

NOW, THEREFORE:

1. Declaration. The Port hereby declares that the Auburn Wetland Mitigation Area shall be subject to the covenants, conditions, and restrictions stated herein which shall be binding on all parties having any right, title, or interest in the Auburn Wetland Mitigation Area (hereinafter the "Mitigation Area") or any part thereof and shall inure to the benefit of each subsequent owner thereof.

2. Purpose. The purpose of this Declaration is to meet the requirements of the federal Clean Water Act and state water quality standards as set forth in Ecology's Order and the Corps Permit, and to restrict development and construction activities within the Mitigation Area.

3. Restrictive Covenants. The Mitigation Area shall be used for wetland mitigation. The Mitigation Area shall also be used for floodwater storage in flood events, but it shall not be used for stormwater management for developed areas (i.e., stormwater detention and water quality treatment). No development activity including clearing, grading, filling, or the construction of any building, structure, or other improvement shall occur in the Mitigation Area, except for the following:

- a. Activities authorized in the Corps/Ecology-approved Natural Resource Mitigation Plan to construct and establish the mitigation. Existing uses in the Mitigation Area may continue until the uses are removed or halted during construction of the mitigation.
- b. Activities necessary for the maintenance and effective functioning of the wetlands and buffers, including but not limited to: (i) monitoring, maintenance, and contingency actions pursuant to Ecology's Order and the Corps Permit; (ii) the removal of exotic, non-native, invasive vegetation; and (iii) maintenance of drainage channels.
- c. Removal of trees that a certified arborist has recommended be removed to prevent a hazard to persons or property. The Port shall replant areas where trees are removed, as necessary to maintain consistency with the Corps/Ecology-approved Natural Resources Mitigation Plan.
- d. Other activities authorized in writing by the Corps and Ecology.

Following any activity in the Mitigation Area, as authorized above, the Port shall restore the Mitigation Area to the condition contemplated in the Corps/Ecology-approved Natural Resource Mitigation Plan (except for any authorized structure or use that will remain in the Mitigation Area).

4. Default; Remedies. Any violation of a covenant or condition in this Declaration shall be considered a violation of Ecology's Order and the Corps Permit, and

this Declaration may be enforced pursuant to the terms of Ecology's Order and the Corps Permit.

5. Binding Effect. The Declaration shall run with the land and be binding upon the Port and its successors and assigns.

6. Captions. The captions and paragraph headings contained in this Declaration are for convenience and reference only and in no way define, describe, extend, or limit the scope or intent of this Declaration, nor the intent of any provision hereof.

7. Recording. This Declaration shall be recorded in the real property records of King County.

8. No Third Party Rights. Nothing in this Declaration, express or implied, is intended to confer upon any person, other than the Port and its successors and assigns, any rights or remedies under or by reason of this Declaration; provided that this Declaration may be enforced by the Corps or Ecology as described herein.

9. Governing Law. This Declaration shall be governed by and construed in accordance with the laws of the state of Washington.

EXECUTED AND EFFECTIVE as of the date first written above.

PORT OF SEATTLE, a Washington municipal corporation

By: _____
Name: _____
Its: _____

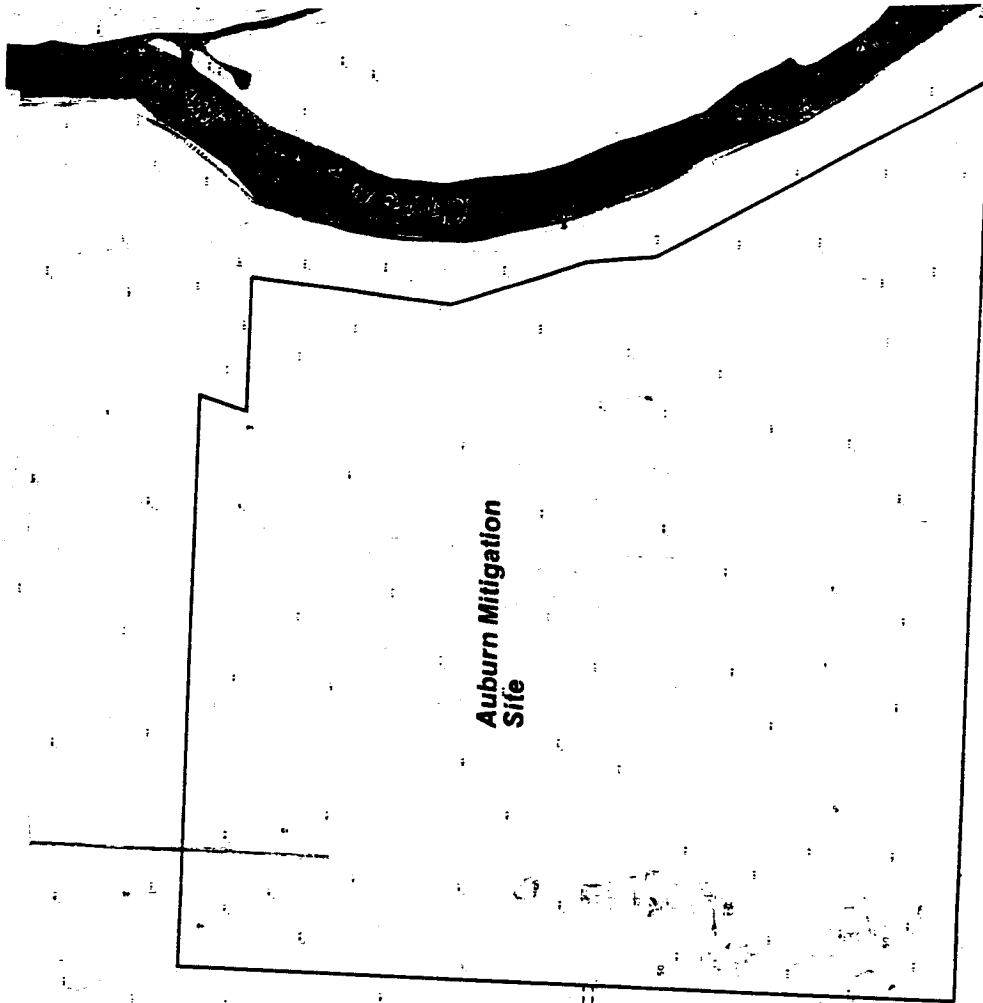
STATE OF WASHINGTON)
) ss.
COUNTY OF _____)

I certify that I know or have satisfactory evidence that _____ signed this instrument, on oath stated that he was authorized to execute the instrument and acknowledged it as the _____ of the Port of Seattle, a Washington municipal corporation, to be the free and voluntary act of such municipal corporation for the uses and purposes mentioned in the instrument.

Dated this _____ day of _____, _____.

(Signature of Notary)

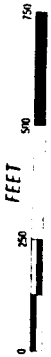
(Legibly Print or Stamp Name of Notary)
Notary public in and for the state of
Washington, residing at _____
My appointment expires: _____



Auburn Mitigation Site

Permanent Access Route

**Restrictive Covenant
at the Port of Seattle
Auburn Property Site**



Scale 1:3000



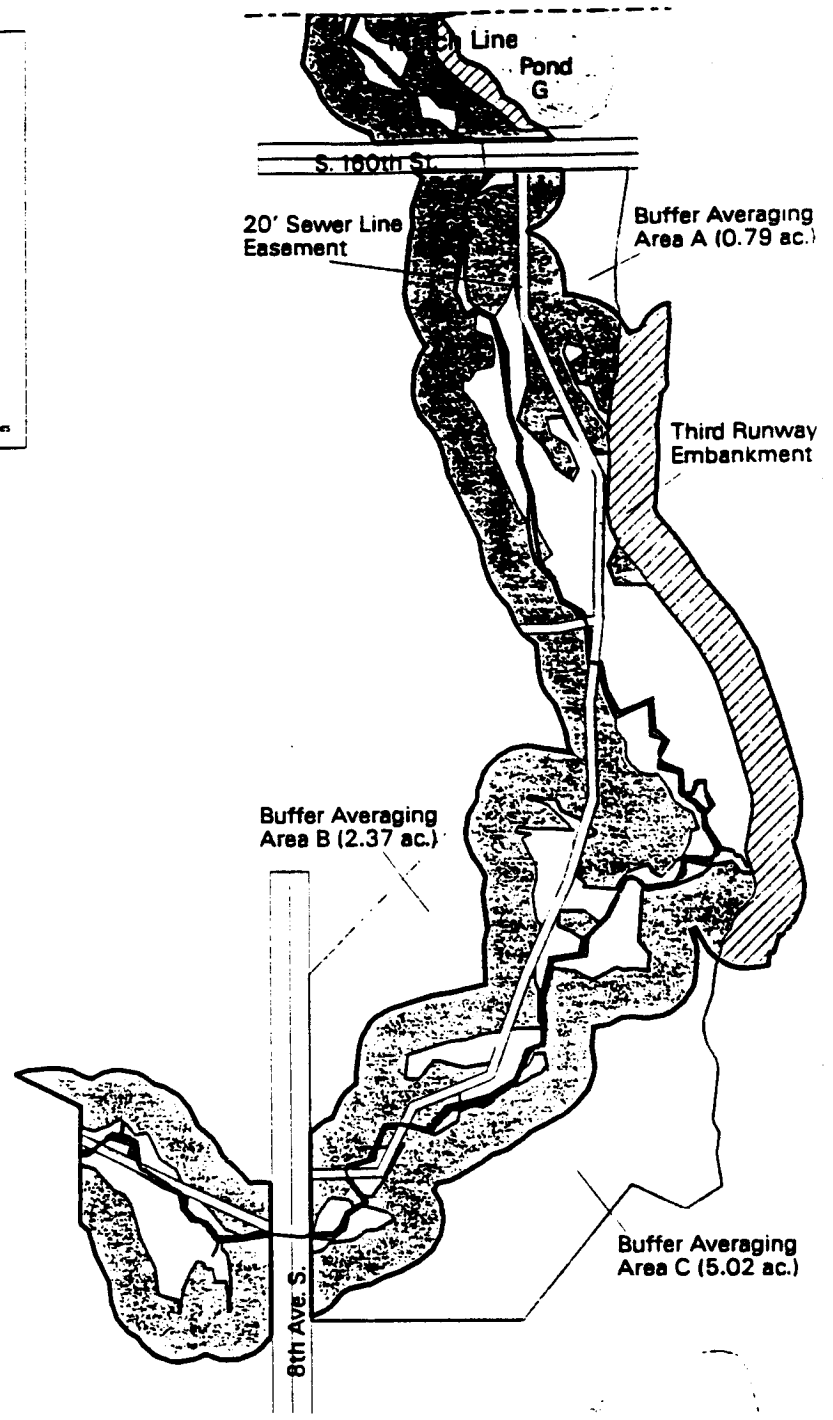
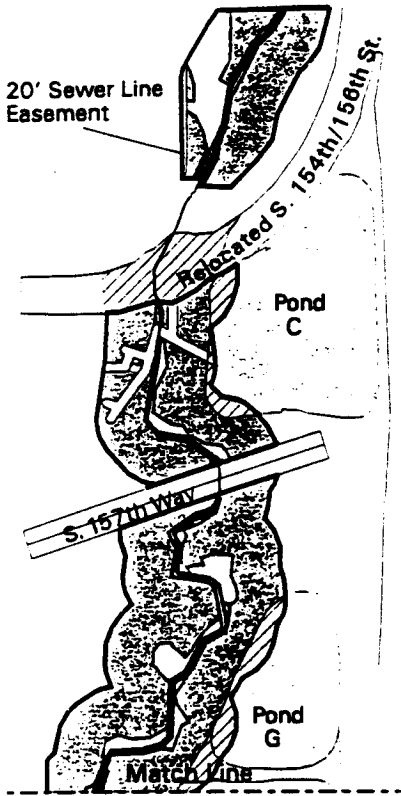
Prepared by: *[illegible]* Date: *[illegible]* Revision: *[illegible]*

- Migration Area in Restrictive Covenant
- - - Permanent Access Route
- Contour Lines (1 ft Interval)
- Roads

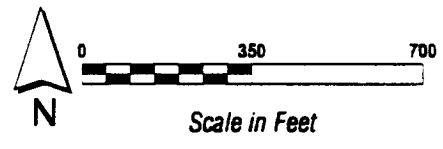
AR 048988

Encroachments Within the Wetland and Riparian Buffer ¹	Area (acres)
Sewer line and 20' easement	1.71
Permanent Stormwater Ponds (C and G)	0.84
Third Runway and Relocated South 154 St. South 156 th St.	3.95
Total Buffer Encroachment	6.50
Buffer Averaging Area	Area (acres)
Area A	0.79
Area B	2.37
Area C	5.02
Total Buffer Averaging Area	8.18

¹ Total area in Miller Creek buffer and Buffer Averaging Area is approximately 46 acres



seazac2/plotamis/p_bufavg1_6x11_0822.dwg creating bufavg1.gra Date: December 13, 2000



- Miller Creek Wetland and Riparian Buffer
- Buffer Averaging Area
- 3rd Runway and New Road Encroachment
- 20' Sewer Easement
- Permanent Pond
- Area of Buffer Encroachment
- Riparian Wetlands
- Miller Creek

Figure 5.2-3
Buffer Averaging
Analyses For Miller
Creek Wetland and
Riparian Buffer

APPENDIX G

**SEA-TAC THIRD RUNWAY – BORROW AREA 3 PRESERVATION
OF WETLANDS**

AR 048990



MEMORANDUM

DATE: October 20, 2000

TO: Jim Thomson, HNTB

FROM: Michael A.P. Kenrick, P.E., and Michael J. Bailey, P.E., Hart Crowser

**RE: Sea-Tac Third Runway – Borrow Area 3
Preservation of Wetlands
J-4978-06**

Anchorage

Boston

Chicago

Denver

As requested by the Port of Seattle, this memo and the attached figures provide conceptual design and supporting information for the proposed drainage swale to protect wetlands in Borrow Area 3. We also provide a brief explanation of the hydrology that supports the wetlands, including why excavation of Borrow Area 3 will not drain these wetlands. Figure 1 shows the location of Borrow Area 3 to the south of Sea-Tac Airport.

Fairbanks

REVIEW OF BORROW AREA 3 WETLAND HYDROLOGY

The first section of this memo provides a review and explanation of the hydrology that currently supports and sustains wetlands in Borrow Area 3. Understanding these hydrologic factors is important in ensuring the long-term preservation of the wetlands during and after excavation of the fill materials contained in Borrow Area 3.

Jersey City

Juneau

Factors Promoting Preservation of the Wetlands

Existing wetlands and current topography in Borrow Area 3 are shown on Figure 2; the proposed area of mining and resulting contours for final excavation are shown on Figure 3.

Long Beach

The series of wetlands mapped in Borrow Area 3 follow a line of shallow depressions in the southcentral part of the site, extending to the southeast from Wetland 29 through Wetlands B9, 30, B7, B6, and B5. These wetlands exist in an area of relatively permeable subsoils where the main groundwater table is at a depth of 10 to 15 feet below the wetlands. Depth of the water table indicates the wetlands are supported by other sources of water. The sources of water appear to include surficial runoff and shallow interflow, as well as

Portland

Seattle



groundwater seepage occurring from a perched zone above the main water table that discharges in the area of Wetland 29. Observation wells in the area indicate the perched zone does not contribute flow directly to the other wetlands but, by extension, flow from Wetland 29 appears to pass along the line of wetlands, to each wetland in turn.

The key factors for sustaining wetland hydrology in Borrow Area 3 are (1) ensuring the continued supply of water and (2) preventing the undue loss of water from the wetlands. Wetland hydrology is typically sustained by a combination of hydrologic processes, as shown schematically on Figure 4. The processes supporting wetland hydrology include precipitation (P), groundwater flow (GW) and spring seepage (Sp), runoff (RO), and interflow (IF). Other processes such as evapotranspiration (Et) and deep percolation (DP) lead to the potential loss of water from wetlands. Where wetlands exist, it can be assumed that the sources of water exceed the losses, for at least a large part of the year. Maintenance of the water sources, without increasing the losses, should ensure preservation of the wetlands in perpetuity.

One of the main constraints on wetland development in the area is the relatively high permeability of the surficial soils. In agricultural terms, the surficial soils are identified to be part of the Indianola series (USDA, 1973) and are characterized as being "excessively drained" with "rapid permeability." This is consistent with the predominant soil material in Borrow Area 3 being stratified glacial drift, which is primarily sand and gravel outwash with varying amounts of silt in a predominantly granular matrix.

The overall approach for maintaining wetlands in Borrow Area 3 focuses on preserving or enhancing the existing sources of water, and ensuring that no additional loss pathways are created.

Wetland 29

Wetland 29 is unique in that it occurs on a hillside (see Figure 3). Its existence is attributable primarily to a continuous supply of groundwater that seeps from the hillside at this point. Investigation of subsurface conditions at Borrow Area 3 links this area of seepage with a laterally continuous zone of perched groundwater that extends to the north and west, behind Wetland 29 (Hart Crowser, 1999, see reference list following the text of this memo). In hydrologic terms, the wetland occupies part of a surface seepage discharge area for groundwater flowing through the perched zone, as illustrated in the cross section on Figure 4. Part of the seepage from the perched zone flows into Wetland 29, the rest of the seepage from the perched layer does not appear elsewhere on the surface, so is assumed to



percolate down into the shallow regional aquifer in the eastern part of the site where the perching layer has been removed by erosion.

The proposed borrow area excavation to the east of Wetland 29 (Figures 3 and 4) will not interfere with the perching layer behind or beneath the wetland and will, therefore, have no direct effect on the continued discharge of groundwater from the west. An analysis of groundwater flow potentially diverted from Wetland 29 (Hart Crowser, 2000) indicates that excavation could change the seepage gradient and result in a decrease in flow to Wetland 29. Mitigation to address this potential change is discussed below.

Although the base of the Borrow Area 3 excavation will be lower in elevation than most of Wetland 29, excavation will occur in predominantly permeable soils that are above the water table. These existing permeable soils already provide a drainage pathway for seepage losses from the wetlands. The persistence of the wetlands despite the presence of permeable soils and a relatively deep water table demonstrates that wetlands will not be drained by the adjacent excavations.

Other Wetlands

Water in Wetland 29 is primarily lost by percolation to the underlying aquifer and evapotranspiration. A portion of the water flowing through Wetland 29 is inferred to move downslope as interflow or shallow subsurface flow to feed successive wetlands that trend southeastward from Wetland 29, occupying a series of shallow depressions (see Figure 3 - note that this flow is out of the plane of the cross section on Figure 4). This inference is based on the topographic position of the adjacent wetlands and the absence of other sources of water. Flow appears to move from one wetland to the next, and some water is likely lost as deep percolation into the permeable subsurface soils that underlie most of the site, including the wetlands. Some additional water probably comes as surface runoff or interflow from the surface catchments feeding each wetland.

According to the Wetland Delineation Report (Parametrix, 1999) and supporting Field Data Sheets, the wetlands in Borrow Area 3 typically feature 10 to 12 inches of "black muck" - a fine-grained richly organic soil that appears to help the ponding of water in the wetland, and likely retains saturation of the root zone rather than allowing much of the water to percolate downward. The concept is illustrated on Figure 5, which is a cross section through Wetland 30.

Note that Wetlands 30, B7, B6, and B5 appear to exist beyond the main perching layer. It is possible that these wetlands formed on locally silty (less permeable) zones in the



predominantly granular soil, promoting shallow perched conditions that sustain the wetland hydrology. As evidence of this, Wetland B7 is reported to have a seasonally high water table that would be 10 to 15 feet above the main groundwater table in the underlying relatively permeable shallow regional aquifer. As a result, excavation of the perching layer northeast of Wetland 29 would not have any direct impact on the other wetlands in Borrow Area 3 provided flow into Wetland 29 is maintained as described below.

Proximity of Excavations

The Port proposes that excavations of Borrow Area 3 (see Figure 3) will leave at least a 50-foot buffer around the wetlands. Excavation to the east of the wetlands will proceed to approximate elevation 233 to 235 feet, whereas the wetlands themselves are at approximate elevations 236 feet (Wetland 30) and 235 to 238 feet (Wetlands B6 and B7), see Figures 5 and 6. The hydrology of these wetlands will not be adversely impacted by the excavations because:

- ▶ The wetlands already exist over permeable subsoils;
- ▶ The buffer will be retained, preventing any lateral "short circuit" flowpath that could divert water from the wetlands and into the borrow site excavation; and
- ▶ Base elevations of the proposed excavations are at most only a foot or two lower than the lowest point in these adjacent wetlands.

Wetland B5 is at about elevation 230 feet, well below the proposed excavation. Wetlands B9 and 29 are upslope of the proposed excavation and would be protected against any potential loss of water by the proposed mitigation discussed herein. Wetland B10 is upslope of the perched zone and, therefore, would not be impacted by changes in perched zone flow.

Potential Loss of Surface Flows

In some areas of the buffer zone between the wetlands and the proposed excavation, there may be localized low spots that provide a potential pathway for overland flow to occur from the wetland into the excavation at periods of exceptionally high water levels. If erosion occurs during periods of high water in the wetlands, formation of gullies could divert increased surface flows from the wetlands into the excavations. Erosion will be prevented by preserving existing vegetation in the wetland buffer areas and revegetating the excavated area in accordance with Washington Department of Natural Resources reclamation criteria. However, if erosion threatens the wetland floor, mitigation could easily be accomplished. The Port has proposed a period of wetland monitoring following excavation of the borrow



site. If necessary during or after excavations, berms or other erosion protection will be constructed outside the wetland buffer and on the edge of the excavations to prevent overland flow occurring from the wetland depressions into the adjacent excavation. This element of the mine plan will depend on field surveying for elevation control of the land-surface profile along the buffer zone, reclamation of the site to a stable condition, and monitoring after reclamation, which the Port has already committed to.

DRAINAGE SWALE DESIGN

The remainder of this memo addresses the design of a drainage swale that will provide additional water to Wetland 29 to replace the potential loss of seepage from the perched zone.

As described in Hart Crowser (2000), groundwater modeling suggests the possibility that mining will produce a small change in the groundwater flow regime within the perched zone that feeds Wetland 29. Modeling suggests increased drawdown in the perched zone due to excavation in the Borrow Area 3 (see Figure 3) could cause a shift in the seepage gradient. This change in gradient could reduce groundwater flow by a maximum of about 20 percent of the current flow to Wetland 29, or about 400 ft³/day (roughly 2 gallons per minute). The Port proposes to mitigate this potential indirect impact by collecting groundwater seepage in a swale along the western slope face of the excavation (see Figure 3) and diverting this to Wetland 29.

Overall Concept for Drainage Swale

The proposed drainage swale is designed to collect groundwater seepage from the excavated slope face on the north and west sides of Borrow Area 3, as depicted on Figure 3. The groundwater seepage represents natural flow from the perched zone that is forced to discharge at the cut slope face, as described in detail in Hart Crowser (2000). The flow will be collected and conducted southward in a swale that drains into Wetland 29. Grades along the swale are expected to be between about 1 and 2 percent. A schematic profile along the drainage swale is shown on Figure 7. Modeling shows there is about 2,400 ft³/day of groundwater flow available compared to projected maximum loss to Wetland 29 of 400 ft³/day (Hart Crowser, 2000). There is more than enough seepage flow available to make up any loss in the natural perched zone groundwater flow to Wetland 29.



Adaptive Design Approach

The detailed design and construction of the drainage swale will be modified as needed to take account of field conditions revealed during the excavation of Borrow Area 3. For example, the swale could be lined with HDPE (see Figure 6) if needed to prevent loss of flow in the event soils encountered during construction are more permeable than indicated by the borings. Design, construction, operation, and maintenance issues are described under the following headings.

Typical Cross Section

The typical cross section for the proposed drainage swale is shown on Figure 6(a). This cross section presupposes that a sufficient thickness of natural low-permeability soils (the lateral extension of the perching layer) will be present in the upper part of the bench holding the swale.

Prevention of Leakage

To allow for potential variability in the surface elevation or thickness of the perching zone, the design assumes the invert of the swale may extend below the base of the perching horizon in places, in order to maintain the design slope of 1 to 2 percent. If the perching horizon is thin or even be eroded away in places, this will be revealed as excavation of Borrow Area 3 occurs and the intersection of the perching layer with the final cut slope becomes visible. In the event that field mapping during excavation shows insufficient low-permeability soil is present to form the required subgrade for the unlined drainage swale, the swale grade or alignment could be modified, and/or an impermeable lining (protected by gravel) would be used in the base of the swale to prevent seepage loss, as shown on Figure 6(b).

Control of Excess Flows

The position of the drainage swale at mid-slope around the northern and western sides of Borrow Area 3 will cause the swale to collect surface water runoff during high precipitation. Some precipitation upslope of the swale is likely to infiltrate but may appear as shallow interflow or perched water and contribute to seepage in the swale. Also, if constructed to its full length as shown on Figure 3, the swale is expected to collect more than enough groundwater seepage to make up for the projected maximum loss in flow from Wetland 29.



Two measures are available to deal with these anticipated excess flows:

- 1) A flow-control structure will be constructed in the course of the swale before it enters Wetland 29 (see Figure 9); and
- 2) The length of the swale can also be modified (at time of construction, or after some period of post-construction monitoring) to control the amount of seepage (and runoff) that is collected and diverted to Wetland 29.

The proposed flow control weir or diversion structure will be designed to provide a consistent low flow of seepage into Wetland 29 and enable diversion of excess flow in the drainage swale away from Wetland 29. The excess flow will be diverted along a channel and into the base of Borrow Area 3, where it will infiltrate and/or be handled by the stormwater facilities for managing runoff from the remainder of the borrow area.

The flow control structure will be constructed of reinforced concrete. As illustrated on Figure 9, it will include a narrow flow slot at the lower elevation to enable a continuous low flow from the drainage swale into Wetland 29. The second part of the flow control structure will include a broad overflow weir that will allow water to spill over into a diversion channel during periods of higher flow in the swale. Flow through both the narrow slot and the broad weir will be controlled with adjustable boards as shown on Figure 9. Flow to Wetland 29 will be fine-tuned during the initial maintenance period (following construction) by adjusting the height of the boards placed in each part of the structure. Final flow levels may then be fixed by replacing the boards with masonry at the end of the monitoring period.

Construction

Construction of the drainage swale will be integrated with the mining and reclamation plan for the excavation of Borrow Area 3. This will prevent over-mining of the perching layer in close proximity to the final slope contours for the excavation. Mining will progress from the highest area of the site in the northwest part of Borrow Area 3, working down the slope and reclaiming the upper part of the final cut slope as excavation proceeds. The perched zone will be encountered as wet areas at the base of the working slope. Mining will then step in approximately 20 feet to allow the bench for the drainage swale to be formed in the perching layer beneath the perched zone.

The next stage will be to excavate within the bench width to cut the swale into the perched zone and underlying perching layer. The bench will be cleaned off and graded to form the swale, which will be constructed per the typical cross section. This will provide the



opportunity to determine from field surveying the elevation, profile, and thickness of the perching layer in the area of the final slope. The final design of the swale invert elevations and cross sections will then be adjusted as required to best match subsurface conditions and topography, facilitating final construction the swale at the required elevation on the bench. Mining will then proceed into the lower part of the slope below the drainage swale.

Surface Protection and Reclamation

Reclamation of the borrow area will be accomplished in accordance with Washington Department of Natural Resources criteria and the Port of Seattle landscape plans. Once final grades have been established, the drainage swale and adjacent slopes will be protected from erosion using the same techniques demonstrated to be effective by the embankment construction to date. The excavation slopes will be dressed and hydroseeded with a bonded fiber matrix. The swale will be protected with erosion control matting until grass is established as part of the post-excavation site reclamation.

Operation and Maintenance

Operation of the swale, and particularly the flow control structure, will require monitoring and recordkeeping for an initial period of about two to five years. During this period, the amount of seepage and operation of the flow control weir will be monitored. The weir height may be adjusted to ensure stable and appropriate flows to Wetland 29, which are consistent with plant and ecological requirements of the wetlands.



Long-term operation and maintenance of the swale will be restricted to periodic (annual) inspections of the facility to check the basic integrity of the swale and look for signs of erosion or blockage that could require remedial work by Port grounds maintenance staff.

F:\docs\jobs\497806\DraftWetlandPreservationSwale.doc

Attachments:

References

Figure 1 - Site Location Map

Figure 2 - Pre-Excavation Topography and Wetlands - Borrow Area 3 Perched Zone

Figure 3 - Post-Excavation Topography and Drainage Facilities - Borrow Area 3 Drainage Swale

Figure 4 - Cross Section A - A' through Wetland 29

Figure 5 - Cross Section B - B' through Wetland 30

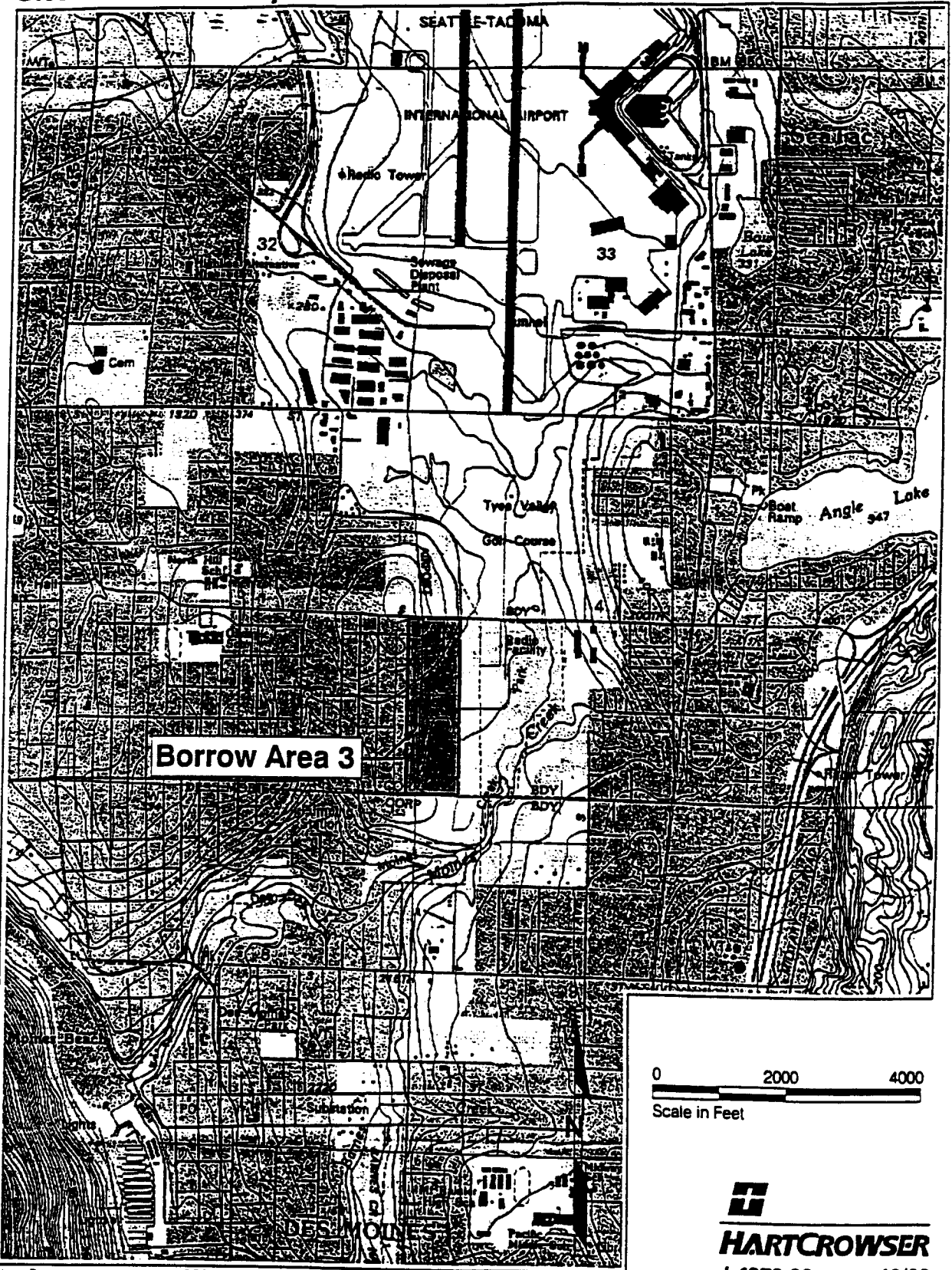
Figure 6 - Cross Section C - C' through Wetland B6

Figure 7 - Drainage Swale - Profile D-D'

Figure 8 - Typical Cross Sections E-E' - Borrow Area 3 Drainage Swale

Figure 9 - Flow Control Structure Schematic - Borrow Area 3 Drainage Swale

Site Location Map



497806A.cgd DTN 101700

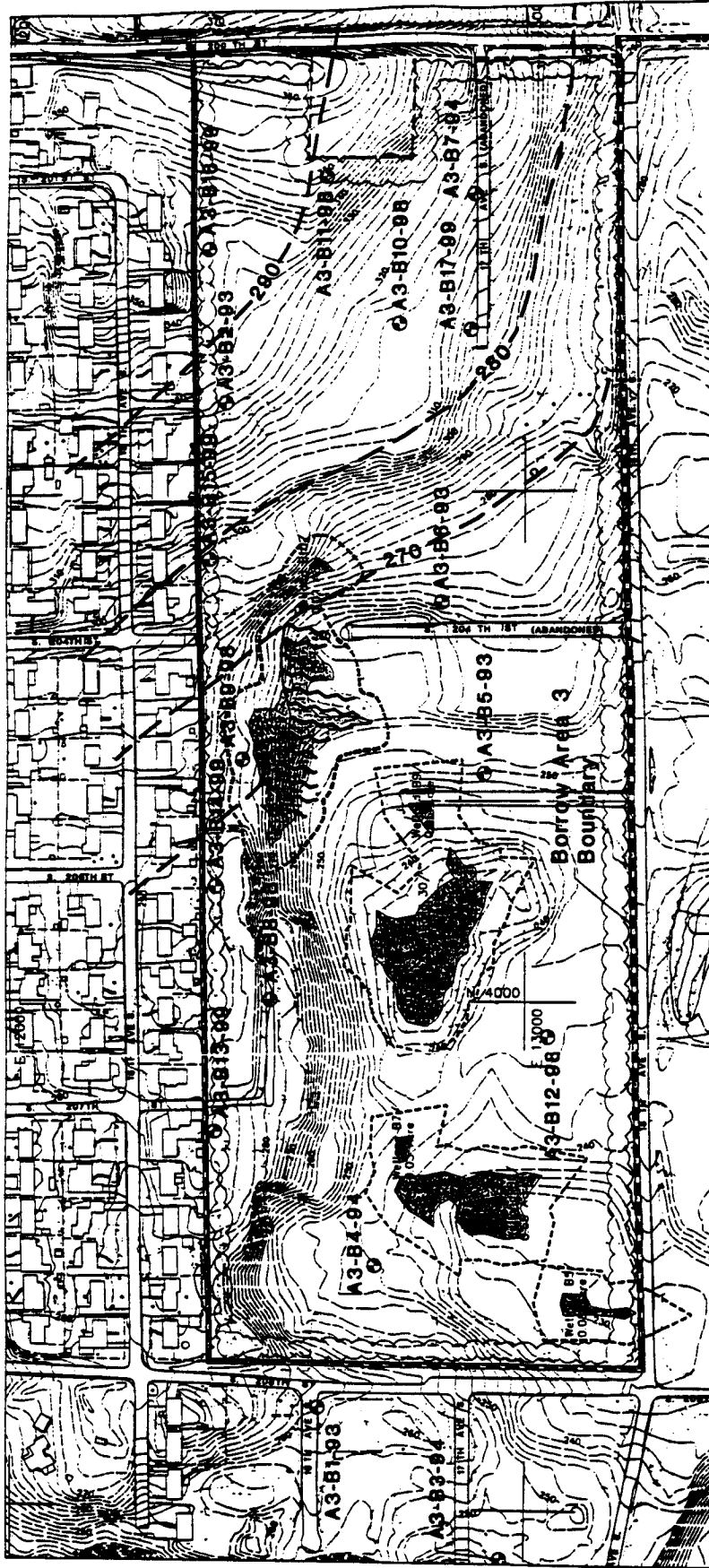
Note: Base map prepared from USGS 7.5 minute quadrangle maps of Seattle South, Washington, revised 1995.

HARTCROWSER
J-4978-06 10/00
Figure 1

AR 049000

Pre-Excavation Topography and Wetlands

Borrow Area 3 Perched Zone



⊙ A3-B4-94

Exploration Boring with Monitoring Well

--280--

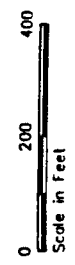
Perched Zone Groundwater Elevation Contour in Feet



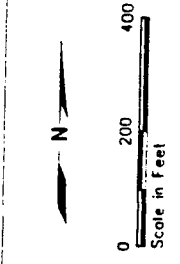
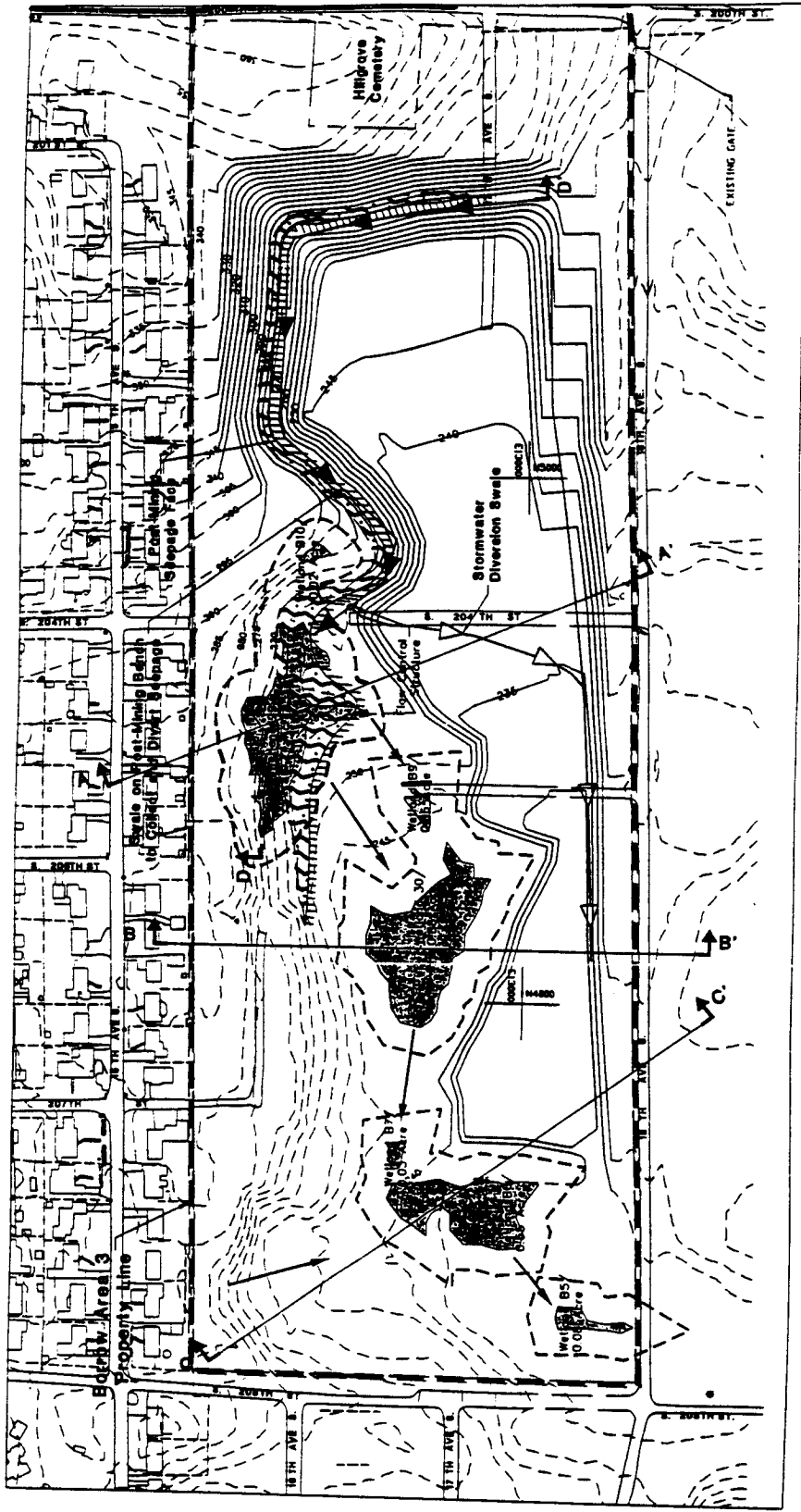
Wetland Location, Designation, Acreage, and 50-foot Wetland Buffer (Based on Parametrix, 1999)

~~~~~

Inferred Seepage Face



**Post-Excavation Topography and Drainage Facilities  
Borrow Area 3 Drainage Swale**



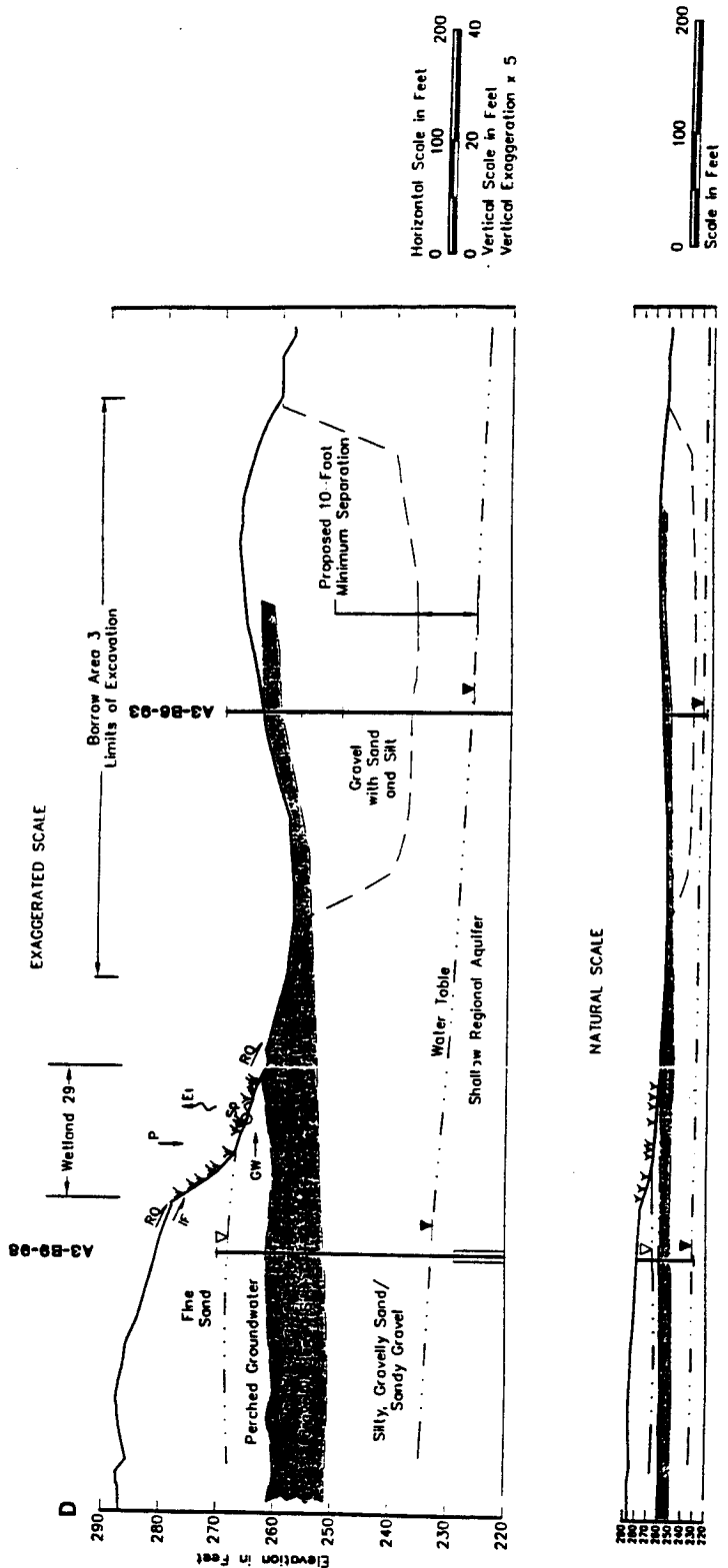
Inferred Seepage Face above Outcrop of Perching Layer  
Cross Section/Profile Location and Designation



240 Proposed Elevation Contour in Feet  
50-Foot Wetland Buffer  
Well Location, Designation, and Acreage  
Direction of Surface/Shallow Subsurface Drainage



# Cross Section A-A' through Wetland 29 Looking North



Horizontal Scale in Feet  
 0 100 200  
 Vertical Scale in Feet  
 0 20 40  
 Vertical Exaggeration x 5

Scale in Feet  
 0 100 200

Note: Contacts between soil units are based upon interpolation between logs and represent our interpretation of subsurface conditions based on currently available data.

**Wetland Hydrology**

Inflows: P Precipitation  
 RO Runoff  
 IF Interflow  
 Sp Springs or Seeps  
 GW Groundwater

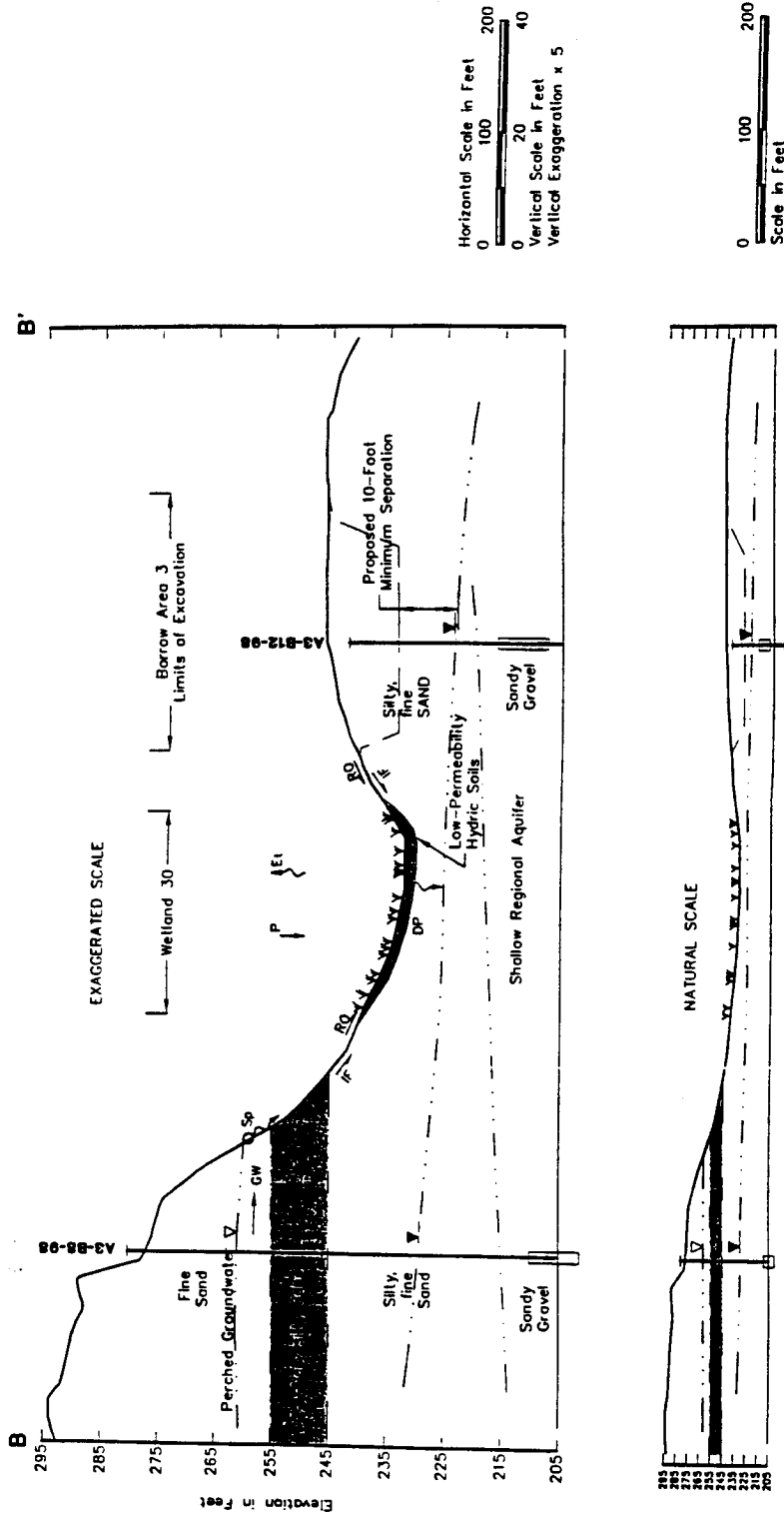
Outflows: ET Evapotranspiration  
 DP Deep Percolation

**A3-BB-00 Exploration Number**

Exploration Location  
 Perched Water Level  
 Shallow Aquifer Water Level  
 Screened Interval

AR 049003

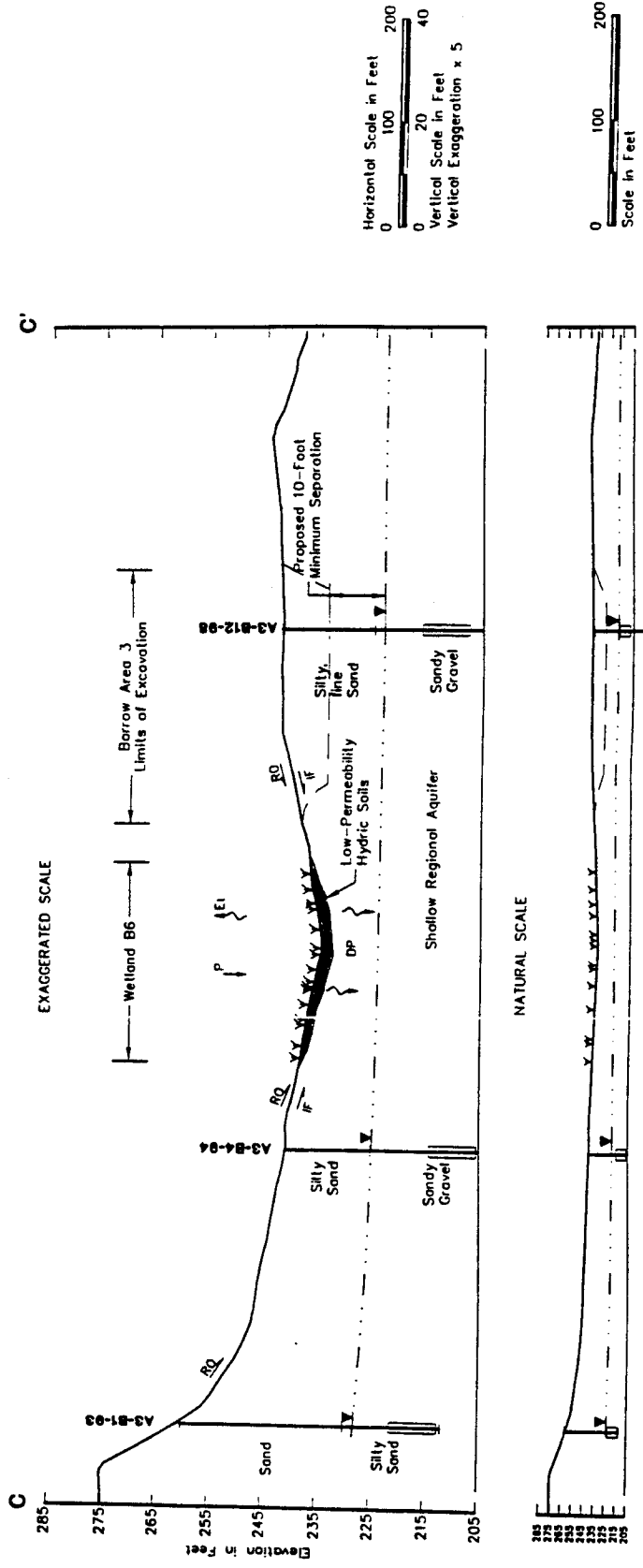
# Cross Section B-B' through Wetland 30 Looking North



Note: Contacts between soil units are based upon interpolation between borings and represent the best estimation of subsurface conditions based on currently available data.

| Welland Hydrology |                       | A3-88-98 Exploration Number |                             |
|-------------------|-----------------------|-----------------------------|-----------------------------|
| Inflows:          | P Precipitation       | RO Runoff                   | Exploration Location        |
|                   | IF Interflow          | Sp Springs or Seeps         | Perched Water Level         |
|                   | GW Groundwater        | DP Deep Percolation         | Shallow Aquifer Water Level |
| Outflows:         | Et Evapotranspiration |                             | Screened Interval           |

# Cross Section C-C' through Wetland B6 Looking North

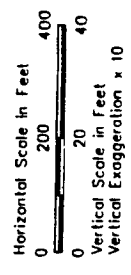
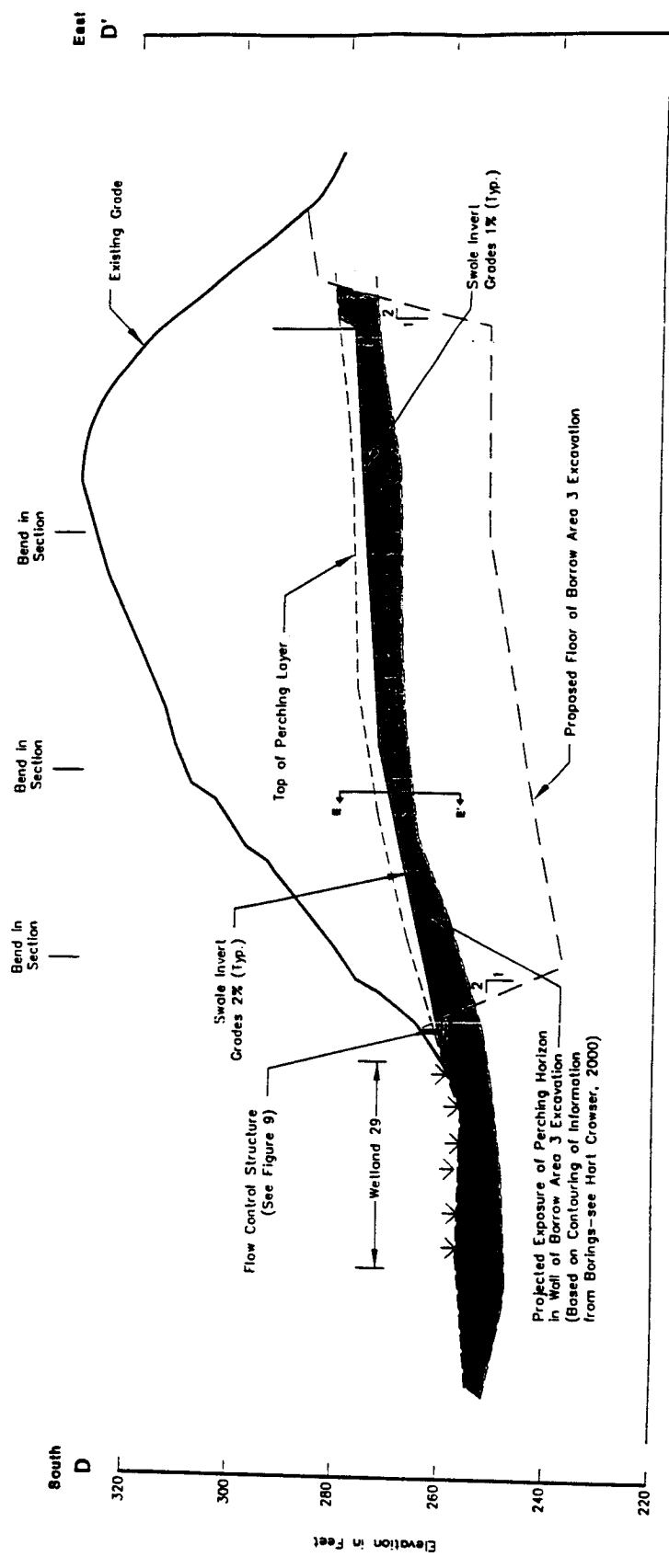


Note: Contacts between soil units are based upon interpolation between logs and represent our interpretation of subsurface conditions based on currently available data.

DATE: 02/17/08 1:08 PM

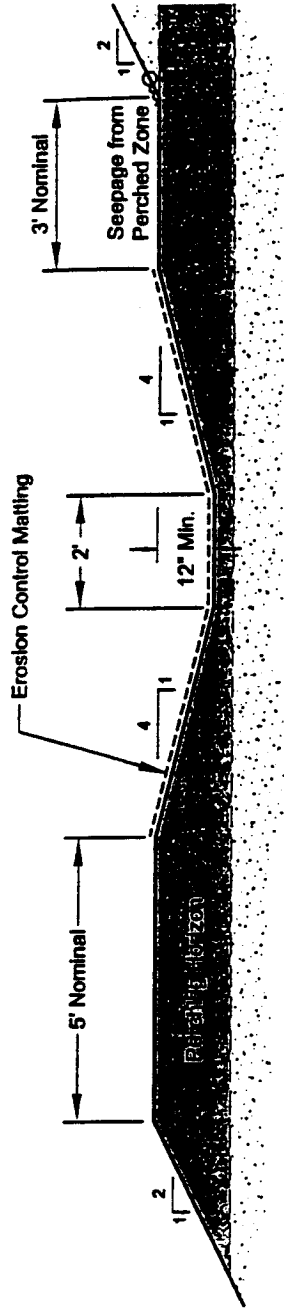
AR 049005

**Drainage Swale - Profile D-D'**  
Borrow Area 3



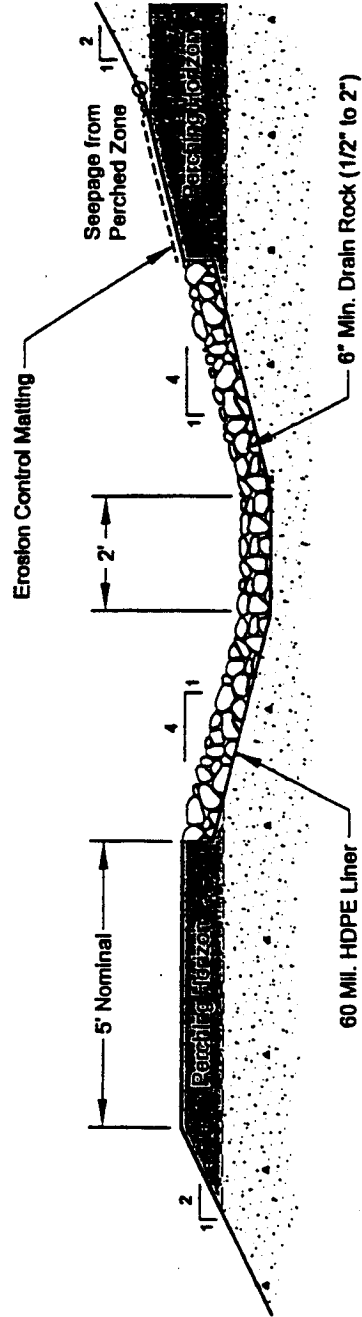


# Typical Cross Sections E-E' Borrow Area 3 Drainage Swale



(a) DRAINAGE SWALE (TYPICAL)

Not to Scale

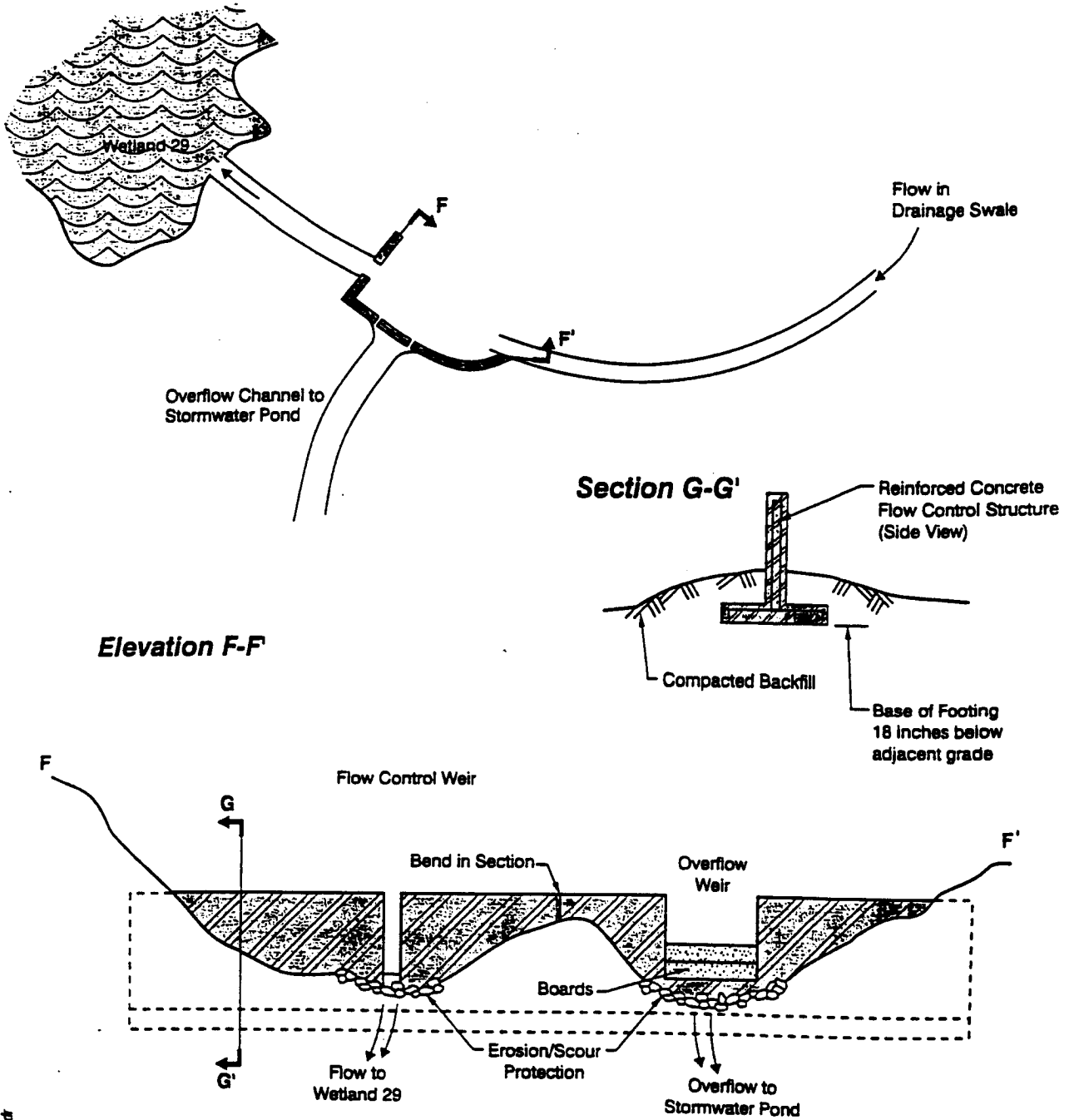


(b) LINED DRAINAGE SWALE (AS NEEDED)

Not to Scale

# Flow Control Structure Schematic

## Borrow Area 3 Drainage Swale



hel 10/18/00 4978068.cdr



**HARTCROWSER**

J-4978-06

10/00

Figure 9

AR 049008

**APPENDIX H**  
**SAMPLE DATA SHEETS**

**AR 049009**

**HYDROLOGIC MONITORING  
SEATTLE-TACOMA INTERNATIONAL AIRPORT  
WETLAND MITIGATION MONITORING  
SURFACE WATER DEPTHS - STAFF GAUGE DATA**

**Wetland:**     Vacca Farm             Tye Golf Course             Auburn  
                   Miller Creek Buffer        Temporary Impacts        Sampling Station: \_\_\_\_\_  
                   Groundwater             Surface Water

| Date | Time | Read By | Water Level <sup>a</sup> | Weather <sup>b</sup> | Notes <sup>c</sup> | Water Quality Notes <sup>d</sup> |
|------|------|---------|--------------------------|----------------------|--------------------|----------------------------------|
|      |      |         |                          |                      |                    |                                  |
|      |      |         |                          |                      |                    |                                  |
|      |      |         |                          |                      |                    |                                  |
|      |      |         |                          |                      |                    |                                  |
|      |      |         |                          |                      |                    |                                  |
|      |      |         |                          |                      |                    |                                  |
|      |      |         |                          |                      |                    |                                  |
|      |      |         |                          |                      |                    |                                  |
|      |      |         |                          |                      |                    |                                  |
|      |      |         |                          |                      |                    |                                  |
|      |      |         |                          |                      |                    |                                  |
|      |      |         |                          |                      |                    |                                  |
|      |      |         |                          |                      |                    |                                  |
|      |      |         |                          |                      |                    |                                  |
|      |      |         |                          |                      |                    |                                  |
|      |      |         |                          |                      |                    |                                  |
|      |      |         |                          |                      |                    |                                  |
|      |      |         |                          |                      |                    |                                  |
|      |      |         |                          |                      |                    |                                  |
|      |      |         |                          |                      |                    |                                  |
|      |      |         |                          |                      |                    |                                  |
|      |      |         |                          |                      |                    |                                  |
|      |      |         |                          |                      |                    |                                  |
|      |      |         |                          |                      |                    |                                  |
|      |      |         |                          |                      |                    |                                  |

<sup>a</sup> Indicate subsurface water levels with a negative sign preceding depth from soil surface to standing water.  
<sup>b</sup> Record observations of present and preceding weather conditions.  
<sup>c</sup> Record species, numbers, and locations.  
<sup>d</sup> Record algae blooms or odors.

**HYDROLOGIC MONITORING – GROUNDWATER ELEVATIONS  
 SEATTLE-TACOMA INTERNATIONAL AIRPORT  
 WETLAND MITIGATION MONITORING  
 GROUNDWATER WELL DATA**

Wetland:    Vacca Farm                       Tye Golf Course                       Auburn  
                    Miller Creek Buffer                       Temporary Impacts                       Sampling Station: \_\_\_\_\_  
                    Groundwater                       Surface Water

| Date | Time | Read By | Water Level <sup>a</sup> | Weather <sup>b</sup> | Notes <sup>c</sup> |
|------|------|---------|--------------------------|----------------------|--------------------|
|      |      |         |                          |                      |                    |
|      |      |         |                          |                      |                    |
|      |      |         |                          |                      |                    |
|      |      |         |                          |                      |                    |
|      |      |         |                          |                      |                    |
|      |      |         |                          |                      |                    |
|      |      |         |                          |                      |                    |
|      |      |         |                          |                      |                    |
|      |      |         |                          |                      |                    |
|      |      |         |                          |                      |                    |
|      |      |         |                          |                      |                    |
|      |      |         |                          |                      |                    |
|      |      |         |                          |                      |                    |
|      |      |         |                          |                      |                    |
|      |      |         |                          |                      |                    |
|      |      |         |                          |                      |                    |
|      |      |         |                          |                      |                    |
|      |      |         |                          |                      |                    |
|      |      |         |                          |                      |                    |
|      |      |         |                          |                      |                    |

<sup>a</sup> Indicate subsurface water levels with a negative sign preceding depth from soil surface to standing water.  
<sup>b</sup> Record observations of present and preceding weather conditions.  
<sup>c</sup> Record algae blooms or odors.

**PHOTOGRAPHIC RECORD  
SEATTLE-TACOMA INTERNATIONAL AIRPORT  
WETLAND MITIGATION MONITORING**

Wetland:  Vacca Farm       Tye Golf Course       Auburn  
 Miller Creek Buffer       Temporary Impacts       Sampling Station: \_\_\_\_\_  
 Groundwater       Surface Water

Date: \_\_\_\_\_

Observer: \_\_\_\_\_

| Location | Photo Numbers | Description/Remarks/Wildlife Observations* |
|----------|---------------|--------------------------------------------|
|          |               |                                            |
|          |               |                                            |
|          |               |                                            |
|          |               |                                            |
|          |               |                                            |
|          |               |                                            |
|          |               |                                            |
|          |               |                                            |
|          |               |                                            |
|          |               |                                            |
|          |               |                                            |
|          |               |                                            |
|          |               |                                            |
|          |               |                                            |
|          |               |                                            |
|          |               |                                            |
|          |               |                                            |
|          |               |                                            |
|          |               |                                            |
|          |               |                                            |
|          |               |                                            |
|          |               |                                            |
|          |               |                                            |
|          |               |                                            |

\* Include species, location, and numbers

**HERBACEOUS VEGETATION COVER DATA  
SEATTLE-TACOMA INTERNATIONAL AIRPORT  
WETLAND MITIGATION MONITORING**

Date: \_\_\_\_\_ Plot: \_\_\_\_\_  
 Transect: \_\_\_\_\_ Observer: \_\_\_\_\_  
 Soil color (at 12-inch depth): \_\_\_\_\_ Water table/Soil moisture: \_\_\_\_\_

Wetland:  Vacca Farm       Tyee Golf Course       Auburn  
 Miller Creek Buffer       Temporary Impacts       Sampling Station: \_\_\_\_\_  
 Groundwater       Surface Water

| Species | Estimated Cover | Cover Class | Remarks |
|---------|-----------------|-------------|---------|
| 1.      |                 |             |         |
| 2.      |                 |             |         |
| 3.      |                 |             |         |
| 4.      |                 |             |         |
| 5.      |                 |             |         |
| 6.      |                 |             |         |
| 7.      |                 |             |         |
| 8.      |                 |             |         |
| 9.      |                 |             |         |
| 10.     |                 |             |         |
| 11.     |                 |             |         |
| 12.     |                 |             |         |
| 13.     |                 |             |         |
| 14.     |                 |             |         |
| 15.     |                 |             |         |

**WOODY PLANT COVER  
SEATTLE-TACOMA INTERNATIONAL AIRPORT  
WETLAND MITIGATION MONITORING**

Date: \_\_\_\_\_  
Soil color (at 12-inch depth): \_\_\_\_\_

Observer: \_\_\_\_\_  
Water table/Soil moisture: \_\_\_\_\_

- Wetland:**     Vacca Farm                       Tyee Golf Course                       Auburn  
                    Miller Creek Buffer                       Temporary Impacts                       Sampling Station: \_\_\_\_\_  
                    Groundwater                       Surface Water

Transect number: \_\_\_\_\_ Length of transect (or interval)  
 \_\_\_\_\_

| Species | Record Intercept Lengths by Species and Occurrences | Intercept Total |
|---------|-----------------------------------------------------|-----------------|
| 1.      |                                                     |                 |
| 2.      |                                                     |                 |
| 3.      |                                                     |                 |
| 4.      |                                                     |                 |
| 5.      |                                                     |                 |
| 6.      |                                                     |                 |
| 7.      |                                                     |                 |
| 8.      |                                                     |                 |
| 9.      |                                                     |                 |
| 10.     |                                                     |                 |
| 11.     |                                                     |                 |
| 12.     |                                                     |                 |
| 13.     |                                                     |                 |
| 14.     |                                                     |                 |
| 15.     |                                                     |                 |



**WETLAND PLANT CONDITION<sup>a</sup>**  
**SEATTLE-TACOMA INTERNATIONAL AIRPORT**  
**WETLAND MITIGATION MONITORING**

Wetland:  Vacca Farm       Tye Golf Course       Auburn  
 Miller Creek Buffer       Temporary Impacts       Sampling Station: \_\_\_\_\_  
 Groundwater       Surface Water

Wetland Zone (circle one): Shrub    Emergent    Open Water    Buffer    Other:

Date: \_\_\_\_\_ Observer: \_\_\_\_\_

| Species | Leaves <sup>b</sup> | % | Shoots <sup>c</sup> | % | Stems <sup>d</sup> | % | Disease <sup>e</sup> | % |
|---------|---------------------|---|---------------------|---|--------------------|---|----------------------|---|
| 1.      |                     |   |                     |   |                    |   |                      |   |
| 2.      |                     |   |                     |   |                    |   |                      |   |
| 3.      |                     |   |                     |   |                    |   |                      |   |
| 4.      |                     |   |                     |   |                    |   |                      |   |
| 5.      |                     |   |                     |   |                    |   |                      |   |
| 6.      |                     |   |                     |   |                    |   |                      |   |
| 7.      |                     |   |                     |   |                    |   |                      |   |
| 8.      |                     |   |                     |   |                    |   |                      |   |
| 9.      |                     |   |                     |   |                    |   |                      |   |
| 10.     |                     |   |                     |   |                    |   |                      |   |
| 11.     |                     |   |                     |   |                    |   |                      |   |
| 12.     |                     |   |                     |   |                    |   |                      |   |
| 13.     |                     |   |                     |   |                    |   |                      |   |
| 14.     |                     |   |                     |   |                    |   |                      |   |

<sup>a</sup> Attach site map of wetland to indicate specific areas examined and reported on this data sheet  
<sup>b</sup> Note leaf color, size, and shape abnormalities  
<sup>c</sup> Note typical shoot elongation for current season, and abnormalities (including die-back)  
<sup>d</sup> Note stem die-back, if any  
<sup>e</sup> Record diseases or pests (including insect or animal grazing)

Final

## **Natural Resource Mitigation Plan**

# **Master Plan Update Improvements Seattle-Tacoma International Airport**

---



November 2001

---

**Parametrix, Inc.**

**AR 049016**

**NATURAL RESOURCE MITIGATION PLAN  
SEATTLE-TACOMA INTERNATIONAL AIRPORT  
MASTER PLAN UPDATE IMPROVEMENTS**

Prepared for

**PORT OF SEATTLE**  
Seattle-Tacoma International Airport  
P.O. Box 69727  
Seattle, Washington 98168-0727

Prepared by

**PARAMETRIX, INC.**  
5808 Lake Washington Blvd. N.E., Suite 200  
Kirkland, Washington 98033-7350

November 2001  
556-2912-001 (03)

**AR 049017**

## TABLE OF CONTENTS

|                                                                                       | <u>Page</u> |
|---------------------------------------------------------------------------------------|-------------|
| EXECUTIVE SUMMARY.....                                                                | XII         |
| 1. INTRODUCTION .....                                                                 | 1-1         |
| 1.1 PURPOSE AND NEED FOR THE PROJECT .....                                            | 1-2         |
| 1.2 PROJECT LOCATION.....                                                             | 1-3         |
| 1.3 PROJECT DESCRIPTION.....                                                          | 1-3         |
| 1.3.1 Runways and Taxiways .....                                                      | 1-10        |
| 1.3.2 Runway Safety Area Extensions / South 154 <sup>th</sup> Street Relocation ..... | 1-10        |
| 1.3.3 The South Aviation Support Area.....                                            | 1-12        |
| 1.3.4 On-Site Borrow Source Areas.....                                                | 1-12        |
| 1.3.5 Other Support Facilities .....                                                  | 1-14        |
| 1.4 RESPONSIBLE PARTIES .....                                                         | 1-14        |
| 1.5 DOCUMENT ORGANIZATION .....                                                       | 1-14        |
| 2. EXISTING CONDITIONS IN THE PROJECT AREA.....                                       | 2-1         |
| 2.1 WETLANDS .....                                                                    | 2-1         |
| 2.1.1 Wetland Delineation Methodology.....                                            | 2-1         |
| 2.1.2 Wetland Descriptions .....                                                      | 2-7         |
| 2.2 STREAMS.....                                                                      | 2-7         |
| 2.2.1 Miller Creek Basin .....                                                        | 2-7         |
| 2.2.2 Des Moines Creek Basin.....                                                     | 2-15        |
| 2.2.3 Gilliam Creek .....                                                             | 2-16        |
| 3. NATURAL RESOURCE IMPACTS SUMMARY.....                                              | 3-1         |
| 3.1 WETLANDS .....                                                                    | 3-1         |
| 3.1.1 Permanent Impacts .....                                                         | 3-1         |
| 3.1.2 Temporary Construction Impacts .....                                            | 3-6         |
| 3.1.3 Fragmentation and Indirect Impacts .....                                        | 3-6         |
| 3.1.4 Watershed Impacts .....                                                         | 3-11        |
| 3.2 STREAMS.....                                                                      | 3-11        |
| 3.3 FLOODPLAINS.....                                                                  | 3-11        |
| 3.4 DRAINAGE CHANNELS.....                                                            | 3-14        |
| 3.5 WATER QUANTITY AND WATER QUALITY.....                                             | 3-14        |
| 4. SUMMARY OF MITIGATION, MONITORING, MAINTENANCE, AND CONTINGENCIES.....             | 4-1         |
| 4.1 MITIGATION STRATEGY .....                                                         | 4-1         |
| 4.1.1 On-Site Mitigation.....                                                         | 4-15        |
| 4.1.2 Off-Site Mitigation.....                                                        | 4-19        |
| 4.2 ECOLOGICAL FUNCTIONS PROVIDED BY THE MITIGATION .....                             | 4-20        |
| 4.2.1 Vacca Farm Restoration and Miller Creek Relocation.....                         | 4-20        |
| 4.2.2 Miller Creek Buffer Wetland Enhancement .....                                   | 4-23        |
| 4.2.3 Des Moines Way Nursery Wetland Restoration.....                                 | 4-29        |
| 4.2.4 Functions Planned for the Tye Valley Golf Course Mitigation Site .....          | 4-32        |
| 4.2.5 Wetland Mitigation in Auburn.....                                               | 4-33        |
| 4.3 MONITORING PLAN AND CONTINGENCY MEASURES.....                                     | 4-35        |

## TABLE OF CONTENTS (continued)

|                                                                              | <u>Page</u> |
|------------------------------------------------------------------------------|-------------|
| 4.3.1 Monitoring Approach.....                                               | 4-35        |
| 4.3.2 Adaptive Management Approach .....                                     | 4-43        |
| 5. ON-SITE MITIGATION PROJECTS .....                                         | 5-1         |
| 5.1 VACCA FARM MITIGATION .....                                              | 5-2         |
| 5.1.1 Miller Creek Relocation and Channel Restoration Plan.....              | 5-3         |
| 5.1.2 Vacca Farm Floodplain and Wetland Restoration Plan.....                | 5-28        |
| 5.1.3 Lora Lake Shoreline Enhancement .....                                  | 5-47        |
| 5.1.4 Implementation of the Vacca Farm Mitigation Projects.....              | 5-52        |
| 5.2 MILLER CREEK RIPARIAN AND<br>INSTREAM ENHANCEMENT PROJECTS .....         | 5-63        |
| 5.2.1 Miller Creek Riparian Corridor Wetland and Buffer Enhancement Plan .   | 5-64        |
| 5.2.2 Miller Creek Instream Habitat Enhancement Plan .....                   | 5-78        |
| 5.2.3 Drainage Channel Replacement Plan.....                                 | 5-106       |
| 5.2.4 Wetland Restoration Plan for Temporary Construction Impacts .....      | 5-117       |
| 5.2.5 Miller Creek Basin Trust Fund for Watershed Rehabilitation .....       | 5-127       |
| 5.3 DES MOINES CREEK BASIN RESTORATION PROJECTS .....                        | 5-130       |
| 5.3.1 Tyee Valley Golf Course Area Mitigation Plans.....                     | 5-130       |
| 5.3.2 Des Moines Creek Basin Trust Fund for Watershed Rehabilitation .....   | 5-146       |
| 5.3.3 Preventing Indirect Impacts to Wetland Near Borrow Areas 1 and 3 ..... | 5-149       |
| 6. HYDROLOGIC IMPACTS AND MITIGATION .....                                   | 6-1         |
| 6.1 WATER QUANTITY .....                                                     | 6-1         |
| 6.1.1 Stormflow Impacts .....                                                | 6-1         |
| 6.1.2 Base Flow Impacts .....                                                | 6-16        |
| 6.2 WATER QUALITY .....                                                      | 6-17        |
| 7. OFF-SITE HABITAT MITIGATION: AUBURN WETLAND MITIGATION .....              | 7-1         |
| 7.1 GOALS, OBJECTIVES, AND DESIGN CRITERIA.....                              | 7-2         |
| 7.1.1 Goals and Objectives.....                                              | 7-5         |
| 7.2 WETLAND MITIGATION SITE .....                                            | 7-5         |
| 7.2.1 Site Description .....                                                 | 7-5         |
| 7.2.2 Ownership .....                                                        | 7-7         |
| 7.2.3 Rationale for Selection .....                                          | 7-9         |
| 7.2.4 Constraints.....                                                       | 7-18        |
| 7.2.5 Ecological Assessment of the Mitigation Site .....                     | 7-18        |
| 7.3 MITIGATION SITE DESIGN.....                                              | 7-43        |
| 7.3.1 Water Regime.....                                                      | 7-44        |
| 7.3.2 Grading.....                                                           | 7-48        |
| 7.3.3 Landscape Plan.....                                                    | 7-56        |
| 7.3.4 Native Plant Communities .....                                         | 7-60        |
| 7.4 IMPLEMENTATION .....                                                     | 7-68        |
| 7.4.1 Pre-construction Meeting .....                                         | 7-68        |
| 7.4.2 Site Preparation and Planting .....                                    | 7-68        |
| 7.4.3 Erosion Control .....                                                  | 7-72        |
| 7.4.4 Excavation and Grading .....                                           | 7-73        |
| 7.4.5 Construction Access Roads, Staging Areas, and Maintenance Roads .....  | 7-73        |
| 7.4.6 Temporary Irrigation.....                                              | 7-75        |

**TABLE OF CONTENTS (continued)**

|     |                                                                  | <u>Page</u> |
|-----|------------------------------------------------------------------|-------------|
|     | 7.4.7 Establish Native Wetland and Upland Buffer Vegetation..... | 7-75        |
|     | 7.4.8 Record Report and Monitoring .....                         | 7-75        |
|     | 7.4.9 Construction Steps.....                                    | 7-76        |
| 7.5 | MONITORING AND PERFORMANCE STANDARDS.....                        | 7-79        |
|     | 7.5.1 Record Drawings and Baseline Monitoring Report .....       | 7-79        |
|     | 7.5.2 15-Year Monitoring Plan .....                              | 7-80        |
| 7.6 | SITE PROTECTION.....                                             | 7-84        |
| 7.7 | MAINTENANCE AND CONTINGENCY PLANS .....                          | 7-84        |
|     | 7.7.1 Routine Maintenance .....                                  | 7-84        |
|     | 7.7.2 Contingency Measures.....                                  | 7-85        |
|     | 7.7.3 Performance Standards.....                                 | 7-92        |
| 8.  | REFERENCES.....                                                  | 8-1         |

**APPENDICES**

(Note: Appendices A through F are under separate cover)

- A MITIGATION DESIGN DRAWINGS – MILLER CREEK RELOCATION
- B MITIGATION DESIGN DRAWINGS – MILLER CREEK INSTREAM AND BUFFER ENHANCEMENTS
- C MITIGATION DESIGN DRAWINGS – TYEE VALLEY GOLF COURSE AND DES MOINES CREEK BUFFER
- D MITIGATION DESIGN DRAWINGS – REPLACEMENT DRAINAGE CHANNELS AND RESTORATION OF TEMPORARILY IMPACTED WETLANDS
- E MITIGATION DESIGN DRAWINGS – AUBURN WETLAND MITIGATION
- F MITIGATION DESIGN DRAWINGS –DES MOINES WAY NURSERY
- G RESTRICTIVE COVENANTS FOR MITIGATION AREAS
- H SEA-TAC THIRD RUNWAY – BORROW AREA 3 PRESERVATION OF WETLANDS
- I SAMPLE DATA SHEETS AND PERMANENT REFERENCE POINT LOCATIONS
- J MILLER CREEK MITIGATION AREA BUFFER AVERAGING ANALYSIS
- K COASTAL CUTTHROAT TROUT HABITAT REQUIREMENTS
- L GROUNDWATER AND VEGETATION MONITORING FOR INDIRECT IMPACTS
- M MILLER CREEK CHANNEL CONDITIONS
- N DES MOINES WAY NURSERY MITIGATION PROJECT
- O CHANGES IN PEAT SOIL CONDITIONS AT THE VACCA FARM MITIGATION AREA
- P FENCING PLAN FOR PROTECTING MITIGATION AREAS
- Q AVOIDANCE OF WETLAND IMPACTS, TEMPORARY STORMWATER POND A

## LIST OF FIGURES

| <u>Figure</u>                                                                                                               | <u>Page</u> |
|-----------------------------------------------------------------------------------------------------------------------------|-------------|
| 1.2-1 Location of Seattle-Tacoma International Airport and Off-Site Wetland Mitigation Site                                 | 1-4         |
| 1.2-2 Locations of Existing Water Features, Stormwater Facilities, Watershed Boundaries, and Acquisition Area of STIA ..... | 1-5         |
| 1.3-1 Master Plan Update Improvement Projects at STIA .....                                                                 | 1-11        |
| 1.3-2 Existing and Relocated South 154 <sup>th</sup> /156 <sup>th</sup> Street .....                                        | 1-14        |
| 2.1-1 Wetland Study Area for the Master Plan Update at STIA .....                                                           | 2-2         |
| 2.1-2 Wetlands in the Miller Creek Basin Near STIA .....                                                                    | 2-8         |
| 2.1-3 Wetlands in the Des Moines Creek Basin Near STIA .....                                                                | 2-9         |
| 2.1-4 Existing Wetlands on the Vacca Farm Site .....                                                                        | 2-10        |
| 2.2-1 Location of Miller Creek, Walker Creek, and Des Moines Creek Near STIA .....                                          | 2-11        |
| 2.2-2 Miller Creek 100-year Floodplain.....                                                                                 | 2-13        |
| 3.1-1 Wetland Impacts in the Miller Creek Basin Near STIA.....                                                              | 3-4         |
| 3.1-2 Wetland Impacts in the Des Moines Creek Basin Near STIA .....                                                         | 3-5         |
| 3.1-3 Locations of Temporary Wetland Impacts in the Miller Creek Basin Near STIA .....                                      | 3-8         |
| 3.2-1 Miller Creek Relocation and Floodplain Grading at the Vacca Farm Site .....                                           | 3-14        |
| 3.4-1 Location of Drainage Channel Impacts in the Miller Creek Basin .....                                                  | 3-15        |
| 4.1-1 Avoidance of Wetland and Stream Impacts in the Miller Creek Basin .....                                               | 4-6         |
| 4.1-2 Avoidance of Wetland and Stream Impacts in the Des Moines Creek Basin.....                                            | 4-7         |
| 4.1-3 Locations of Mitigation Projects in the Miller Creek Basin.....                                                       | 4-16        |
| 5.1-1 Vacca Farm Wetland Restoration Grading Plan.....                                                                      | 5-14        |
| 5.1-2 Sediment Transport Velocity vs. Sediment Diameter .....                                                               | 5-16        |
| 5.1-3 Channel Cross Section Miller Creek Location .....                                                                     | 5-17        |
| 5.1-4 Representative Fish Habitat Enhancement Features.....                                                                 | 5-19        |
| 5.1-5 Vacca Farm Planting Plan.....                                                                                         | 5-31        |
| 5.1-6 Typical Section of Miller Creek Floodplain Enhancement .....                                                          | 5-31        |
| 5.1-7 Typical Planting Plan for the Miller Creek Floodplain, Zone 2.....                                                    | 5-41        |
| 5.1-8 Typical Cross Section of Lora Lake Buffer Enhancement.....                                                            | 5-48        |
| 5.2-1 Miller Creek Instream and Buffer Enhancements .....                                                                   | 5-67        |
| 5.2-2 Typical Cross Section of Miller Creek Stream Buffer Enhancement .....                                                 | 5-67        |
| 5.2-3 Typical Planting Plan for the Miller Creek Upland and Streamside Buffer Planting Zones .....                          | 5-76        |
| 5.2-4 Instream Project 1 Existing Conditions .....                                                                          | 5-85        |
| 5.2-5 Instream Project 2 Existing Conditions .....                                                                          | 5-85        |
| 5.2-6 Instream Project 3 Existing Conditions .....                                                                          | 5-88        |
| 5.2-7 Instream Project 4 Existing Conditions .....                                                                          | 5-88        |

**TABLE OF CONTENTS (continued)**

| <u>Figure</u>                                                                                                                        | <u>Page</u> |
|--------------------------------------------------------------------------------------------------------------------------------------|-------------|
| 5.2-8 Instream Project 1 Proposed Conditions .....                                                                                   | 5-89        |
| 5.2-9 Instream Project 2 Proposed Conditions .....                                                                                   | 5-90        |
| 5.2-10 Instream Project 3 Proposed Conditions .....                                                                                  | 5-91        |
| 5.2-11 Instream Project 4 Proposed Conditions .....                                                                                  | 5-92        |
| 5.2-12 Representative Cross Sections of Miller Creek Reference Sites<br>(Surveyed at Parcels 210, 216, 255, 257, 316, and 317) ..... | 5-93        |
| 5.2-13 South 156 <sup>th</sup> Way Bridge Relocation .....                                                                           | 5-96        |
| 5.2-14 Location of Replacement Drainage Channel and Swales along the West Side of<br>the Third Runway Embankment .....               | 5-108       |
| 5.2-15 Cross Section A-A' of the Replacement Drainage Channel, Drainage Collection Swale,<br>and Third Runway Embankment .....       | 5-110       |
| 5.2-16 Cross Section B-B' of the Replacement Drainage Channel, Drainage Collection Swale,<br>and Third Runway Retaining Wall .....   | 5-111       |
| 5.2-17 Typical Planting Plan for Wetland 37 Restoration .....                                                                        | 5-121       |
| 5.2-18 Typical Planting Plan for Restoration of Temporary Wetland Impacts .....                                                      | 5-121       |
| 5.3-1 Location of Wetland Enhancement on the Tye Valley Golf Course,<br>Des Moines Creek Basin .....                                 | 5-131       |
| 6.1-1 Miller, Walker, and Des Moines Creek Watersheds .....                                                                          | 6-2         |
| 6.1-2 Proposed Detention Facilities for Master Plan Projects .....                                                                   | 6-9         |
| 6.1-3 Flow Duration Curve for Miller Creek at SR509 .....                                                                            | 6-12        |
| 6.1-4 Flow Duration Curve for Walker Creek at South 12 <sup>th</sup> Street .....                                                    | 6-13        |
| 6.1-5 Flow Duration Curve for Des Moines Creek at South 200 <sup>th</sup> Street .....                                               | 6-14        |
| 6.1-6 Flow Duration Curve for Miller Creek at MCDF .....                                                                             | 6-15        |
| 7.2-1 Aerial Photograph of the Auburn Wetland Mitigation Site (1999) .....                                                           | 7-6         |
| 7.2-2 Wetlands and Shallow Groundwater Monitoring Well Locations on the<br>Wetland Mitigation Site, Auburn, Washington .....         | 7-8         |
| 7.2-3 Potential Mitigation Sites Evaluated in the Miller Creek and<br>Des Moines Creek Watersheds .....                              | 7-13        |
| 7.2-4 Location of the 100-year Floodplain on and near the Auburn Wetland Mitigation Site ...                                         | 7-23        |
| 7.2-5 Variations in Groundwater (Monitoring Well 1) and Daily Precipitation .....                                                    | 7-24        |
| 7.2-6 Variation in Groundwater (Monitoring Well 3) and Daily Precipitation .....                                                     | 7-25        |
| 7.2-7 Variations in Groundwater (Monitoring Well 5) and Daily Precipitation .....                                                    | 7-26        |
| 7.2-8 Cross Section of Groundwater Elevations (February – August 2000) at the<br>Wetland Mitigation Site .....                       | 7-27        |
| 7.2-9 Groundwater Elevations on the Auburn Wetland Mitigation Site (December 2, 1999)....                                            | 7-28        |
| 7.2-10 Groundwater Elevations on the Auburn Wetland Mitigation Site (March 8, 2000).....                                             | 7-29        |
| 7.2-11 Groundwater Elevations on the Auburn Wetland Mitigation Site (June 2, 2000).....                                              | 7-30        |
| 7.2-12 Soil Types on the Proposed Wetland Mitigation Site.....                                                                       | 7-31        |
| 7.2-13 Typical Soil Profiles at the Wetland Mitigation Site .....                                                                    | 7-32        |



**TABLE OF CONTENTS (continued)**

| <u>Figure</u> |                                                                                                                            | <u>Page</u> |
|---------------|----------------------------------------------------------------------------------------------------------------------------|-------------|
| 7.2-14        | Typical Successional Changes in Forested Wetland Vegetation Following Planting .....                                       | 7-41        |
| 7.3-1         | Relationship of Seasonal Water Level Variations and Soil Surface Elevations to<br>Proposed Wetland Vegetation Classes..... | 7-47        |
| 7.3-2         | Green River Flood Frequency by Month (Based on 1990-1996 Data for Auburn).....                                             | 7-47        |
| 7.3-3         | Wetland Mitigation Grading Plan.....                                                                                       | 7-49        |
| 7.3-4         | Grading Cross Section for Off-Site Wetland Mitigation.....                                                                 | 7-50        |
| 7.3-5         | Wetland Vegetation Classes for the Wetland Mitigation Site.....                                                            | 7-56        |
| 7.3-6         | Plant Associations for the Wetland Mitigation Site.....                                                                    | 7-56        |
| 7.3-7         | Typical Planting Plan Example for the Black Cottonwood Zone and Red Alder Planting<br>Zones .....                          | 7-63        |
| 7.3-8         | Typical Planting Plan for the Oregon Ash and Mixed Forest Planting Zone.....                                               | 7-63        |
| 7.3-9         | Typical Planting Plan for the Western Redcedar and the Shrub Planting Zones.....                                           | 7-66        |
| 7.3-10        | Typical Planting Plan for the Emergent and the Shrub Planting Zones .....                                                  | 7-68        |

## LIST OF TABLES

| <u>Table</u>                                                                                                                                                                              | <u>Page</u> |
|-------------------------------------------------------------------------------------------------------------------------------------------------------------------------------------------|-------------|
| 1.3-1 Proposed Master Plan Update improvement projects at Seattle-Tacoma International Airport. ....                                                                                      | 1-6         |
| 2.1-1 Summary of wetland and other Waters of the U.S. areas in the Seattle-Tacoma International Airport Master Plan Update Area. ....                                                     | 2-3         |
| 3.1-1 Summary of wetland impacts for Seattle-Tacoma International Airport Master Plan Update improvements by construction project. ....                                                   | 3-2         |
| 3.1-2 Summary of permanent wetland impacts by project and wetland category <sup>a</sup> (in acres). ....                                                                                  | 3-6         |
| 3.1-3 Summary of direct temporary construction impacts to wetlands in the proposed Master Plan Update improvement area. ....                                                              | 3-7         |
| 3.1-4. Summary of wetlands disturbed during mitigation activities. ....                                                                                                                   | 3-9         |
| 4.1-1 Summary of mitigation actions and their relation to National Environmental Policy Act, State Environmental Policy Act, and Clean Water Act mitigation sequencing requirements. .... | 4-3         |
| 4.1-2 Summary of compensatory mitigation (on and off site) for watershed, wetland, and stream impacts at Seattle-Tacoma International Airport. ....                                       | 4-8         |
| 4.1-3 Summary of wetland mitigation credit for Seattle-Tacoma International Airport Master Plan Update improvements. (All impacts and mitigation occur in WRIA 9.).....                   | 4-13        |
| 4.2-1 Riparian habitat buffer widths needed to protect riparian habitat functions (modified from Knutsen and Naef [1997]). ....                                                           | 4-26        |
| 4.3-1 Performance standards for vegetation cover (minimum percent) by vegetation zone and monitoring year. ....                                                                           | 4-42        |
| 4.3-2 Invasive plant species that will be monitored and controlled on the mitigation sites. ....                                                                                          | 4-48        |
| 5.1-1 Summary of wetland and buffer mitigation areas at Vacca Farm. ....                                                                                                                  | 5-3         |
| 5.1-2 Mitigation goals, design objectives, and design criteria for the Miller Creek relocation project. ....                                                                              | 5-4         |
| 5.1-3 Estimated base flow rates at the Miller Creek detention facility outlet structure. ....                                                                                             | 5-6         |
| 5.1-4 Flood frequency estimates for Miller Creek at the Miller Creek detention facility control structure. ....                                                                           | 5-6         |
| 5.1-5 Estimated flow rates for Miller Creek channel design. ....                                                                                                                          | 5-14        |
| 5.1-6 Flood frequency estimates for Miller Creek at the Miller Creek detention facility control structure. ....                                                                           | 5-14        |
| 5.1-7 Final performance standards, evaluation approaches, and contingency measures for mitigation projects at Vacca Farm. ....                                                            | 5-22        |
| 5.1-8 Miller Creek relocation mitigation monitoring methods and schedule. ....                                                                                                            | 5-27        |
| 5.1-9 Mitigation goals, design objectives, and design criteria for the Vacca Farm wetland restoration project. ....                                                                       | 5-32        |
| 5.1-10 Groundwater monitoring well data <sup>a</sup> on the Vacca Farm site. ....                                                                                                         | 5-34        |
| 5.1-11 Proposed seed mix for erosion control. ....                                                                                                                                        | 5-37        |
| 5.1-12 Proposed plant list for mitigation projects in Miller and Des Moines Creek basins. ....                                                                                            | 5-39        |
| 5.1-13 Monitoring schedule for wetland restoration and floodplain enhancement at Vacca Farm. ....                                                                                         | 5-45        |
| 5.1-14 Mitigation design objectives and criteria for the buffer enhancement projects at Lora Lake. ....                                                                                   | 5-47        |

## TABLE OF CONTENTS (continued)

| <u>Table</u>                                                                                                                                                           | <u>Page</u> |
|------------------------------------------------------------------------------------------------------------------------------------------------------------------------|-------------|
| 5.1-15 Proposed Implementation Timeline for Vacca Farm Mitigation Projects <sup>a</sup> .....                                                                          | 5-53        |
| 5.2-1 Mitigation goals, design objectives, and design criteria for the Miller Creek wetland and buffer enhancement project.....                                        | 5-67        |
| 5.2-2 Enhancement planting approach along the Miller Creek buffer.....                                                                                                 | 5-71        |
| 5.2-3 Final performance standards, evaluation approach, and contingency measures for wetland and buffer enhancement along Miller Creek. ....                           | 5-72        |
| 5.2-4 Monitoring schedule for the Miller Creek buffer and wetland enhancement project. ....                                                                            | 5-77        |
| 5.2-5 Mitigation goals, design objectives, and design criteria for instream enhancement projects in Miller Creek.....                                                  | 5-79        |
| 5.2-6 Summary of existing conditions in Miller Creek between South 156th Way and Des Moines Memorial Drive.....                                                        | 5-81        |
| 5.2-7 Habitat and geomorphic benefits of Miller Creek instream enhancement features. ....                                                                              | 5-88        |
| 5.2-8 Final performance standards, evaluation approach, and contingency measures for instream habitat enhancements in Miller Creek. ....                               | 5-97        |
| 5.2-9 Monitoring schedule for the instream enhancement projects. ....                                                                                                  | 5-99        |
| 5.2-10 Proposed Implementation Timeline for Miller Creek In-Stream, Wetland, and Riparian Buffer Enhancements Projects.....                                            | 5-102       |
| 5.2-11 Mitigation goals, design objectives, and design criteria for replacement drainage channels. ....                                                                | 5-107       |
| 5.2-12 Final performance standards, evaluation approach, and contingency measures for replacement drainage channels. ....                                              | 5-114       |
| 5.2-13 Monitoring schedule for the replacement drainage channels. ....                                                                                                 | 5-116       |
| 5.2-14 Summary of wetlands subject to temporary construction-related impacts.....                                                                                      | 5-118       |
| 5.2-15 Mitigation design objectives and criteria for restoration of temporary wetland impacts. ....                                                                    | 5-118       |
| 5.2-16 Final performance standards, evaluation measures, and contingency measures for restoration of temporary wetland impacts. ....                                   | 5-124       |
| 5.2-17 Monitoring schedule for restoration of temporary wetland impacts. ....                                                                                          | 5-125       |
| 5.2-18 Potential trust fund projects in the Miller Creek watershed. ....                                                                                               | 5-128       |
| 5.3-1 Mitigation goals, design objectives, and design criteria for wetland and buffer enhancement on the Tyee Valley Golf Course. ....                                 | 5-132       |
| 5.3-2 Final Performance Standards, Evaluation Approach, and Contingency Measures for the Tyee Valley Golf Course and Des Moines Creek Buffer Mitigation Projects. .... | 5-140       |
| 5.3-3 Monitoring schedule for Des Moines Creek Basin mitigation projects. ....                                                                                         | 5-141       |
| 5.3-4 Proposed implementation timeline for Tyee Valley Golf Course and Des Moines Creek Buffer projects.....                                                           | 5-142       |
| 5.3-5 Summary of potential trust fund projects in the Des Moines Creek watershed (projects are as described in the Des Moines Creek Basin Plan, 1997). ....            | 5-147       |
| 5.3-6 Final Performance Standards, Evaluation Approach, and Contingency Measures for Monitoring Borrow Area Wetlands. ....                                             | 5-150       |
| 6.1-1 Summary of Miller, Walker, and Des Moines Creek drainage areas at STIA and change in impervious area between 1994 baseline and 2006 future conditions .....      | 6-5         |
| 6.1-2 Summary of required detention facility volumes. ....                                                                                                             | 6-8         |
| 6.1-3 Summary of flood peak flow frequency results for Miller/Walker Creek subbasins (all values are cfs).....                                                         | 6-10        |
| 6.1-4 Summary of flood peak flow frequency results for Des Moines Creek subbasins (all values are cfs).....                                                            | 6-11        |

**TABLE OF CONTENTS (continued)**

| <u>Table</u>                                                                                                                                 | <u>Page</u> |
|----------------------------------------------------------------------------------------------------------------------------------------------|-------------|
| 6.1-5 Estimated Low Streamflow Changes.....                                                                                                  | 6-16        |
| 7.1-1 Summary of wetland impacts and off-site compensatory design objectives for the proposed Master Plan Update improvements.....           | 7-1         |
| 7.1-2 Mitigation goals with associated design objectives and design criteria for the Auburn mitigation site.....                             | 7-3         |
| 7.2-1 Summary of reported bird strikes at Seattle-Tacoma International Airport (1979-1999)..                                                 | 7-10        |
| 7.2-2 Summary of potential mitigation sites analyzed within the Miller Creek and Des Moines Creek watersheds (see Figure 7.2-3). .....       | 7-14        |
| 7.2-3 Plant species observed on the mitigation site and adjacent riparian areas during delineation site visits in October 1995 and 2000..... | 7-19        |
| 7.2-4 The wetland indicator status (WIS) system for determining a species adaptation to wetland conditions.....                              | 7-20        |
| 7.2-5 Drainage characteristics of soils occurring on the mitigation site.....                                                                | 7-22        |
| 7.2-6 Wildlife species expected to occur in the Auburn wetland mitigation site after construction.....                                       | 7-35        |
| 7.2-7 Potential wildlife use of constructed wetland habitats.....                                                                            | 7-37        |
| 7.2-8 Plant species to be planted at the Auburn wetland mitigation site.....                                                                 | 7-38        |
| 7.3-1 Proposed wetland classes, elevation ranges, and hydrologic regimes.....                                                                | 7-44        |
| 7.3-2 Hydroseed mixtures.....                                                                                                                | 7-55        |
| 7.3-3 Proposed plant species for the black cottonwood/willow association.....                                                                | 7-60        |
| 7.3-4 Proposed plant species list for the red alder/salmonberry association.....                                                             | 7-62        |
| 7.3-5 Proposed plant species list for the Oregon ash association.....                                                                        | 7-62        |
| 7.3-6 Proposed plant species list for the mixed forest association.....                                                                      | 7-64        |
| 7.3-7 Proposed plant species list for the western redcedar association.....                                                                  | 7-65        |
| 7.3-8 Proposed plant species list for the willow/red osier dogwood shrub zone.....                                                           | 7-67        |
| 7.3-9 Proposed species list for the beaked sedge/water parsley emergent zone.....                                                            | 7-68        |
| 7.4-1 Proposed implementation timeline for Auburn wetland mitigation projects.....                                                           | 7-70        |
| 7.5-1 Auburn wetland mitigation site monitoring methods and schedule.....                                                                    | 7-81        |
| 7.7-1 Final performance standards, evaluation approach, and contingency measures for the Auburn wetland mitigation project.....              | 7-86        |

## LIST OF ABBREVIATIONS AND ACRONYMS

| Abbreviation/<br>Acronym | Formal Name                                       |
|--------------------------|---------------------------------------------------|
| ACOE                     | U. S. Army Corps of Engineers                     |
| AMA                      | Aircraft Movement Area                            |
| AOA                      | Airport Operation Area                            |
| ARFF                     | Airport Rescue and Fire Fighting                  |
| ASDE                     | Airport Surface Detection Equipment               |
| ASR                      | Airport Surveillance Radar                        |
| ASTM                     | American Society for Testing Materials            |
| BIBI                     | Benthic Index of Biotic Integrity                 |
| BMPs                     | Best Management Practices                         |
| cfs                      | Cubic feet per second                             |
| CPOM                     | Coarse particulate organic matter                 |
| CWA                      | Clean Water Act                                   |
| cy                       | Cubic yard                                        |
| DNR                      | Washington Department of Natural Resources        |
| Ecology                  | Washington State Department of Ecology            |
| EIS                      | Environmental Impact Statement                    |
| EPA                      | U.S. Environmental Protection Agency              |
| ESA                      | Endangered Species Act                            |
| FAA                      | Federal Aviation Administration                   |
| FEIS                     | Final Environmental Impact Statement              |
| FEMA                     | Federal Emergency Management Agency               |
| FIRM                     | Flood Insurance Rate Map                          |
| FPOM                     | Fine particulate organic matter                   |
| FSEIS                    | Final Supplemental Environmental Impact Statement |
| FW                       | Farmed wetland                                    |
| GIS                      | Geographic information system                     |
| HPA                      | Hydraulic Project Approval                        |
| HSPF                     | Hydrologic Simulation Program-FORTRAN             |
| IFR                      | Instrument Flight Rule                            |
| ILA                      | Interlocal Agreement                              |
| IWS                      | Industrial waste system                           |
| IWTP                     | Industrial waste treatment plant                  |
| JARPA                    | Joint Aquatic Resource Permit Application         |
| KCSWM                    | King County Surface Water Management              |
| LWD                      | Large woody debris                                |
| MSE                      | Mechanically stabilized earth                     |
| NAVAIDS                  | Navigation aids                                   |
| NEPL                     | North Employee Parking Lot                        |

## LIST OF ABBREVIATIONS AND ACRONYMS (continued)

---

| <b>Abbreviation/<br/>Acronym</b> | <b>Formal Name</b>                                                 |
|----------------------------------|--------------------------------------------------------------------|
| NPDES                            | National Pollutant Discharge Elimination System                    |
| NRMP                             | Natural Resource Mitigation Plan                                   |
| OHW                              | Ordinary high water                                                |
| OHWM                             | Ordinary high water mark                                           |
| PGIS                             | Pollution-generating impervious surface                            |
| Port                             | Port of Seattle                                                    |
| RDF                              | Regional detention facility                                        |
| RM                               | River mile                                                         |
| ROW                              | Right-of-way                                                       |
| RPZ                              | Runway protection zone                                             |
| RSA                              | Runway Safety Areas                                                |
| SAMP                             | Special Areas Management Plan                                      |
| SASA                             | South Aviation Support Area                                        |
| SCS                              | Soil Conservation Service                                          |
| SDS                              | Stormwater drainage system                                         |
| SR                               | State Route                                                        |
| STEP                             | South Terminal Expansion Project                                   |
| STIA                             | Seattle-Tacoma International Airport                               |
| STS                              | Satellite Transit Shuttle                                          |
| SWPPP                            | Stormwater Pollution Prevention Plan                               |
| TESC                             | Temporary erosion and sediment control                             |
| USDA-WSD                         | United States Department of Agriculture-Wildlife Services Division |
| USFWS                            | U.S. Fish and Wildlife Service                                     |
| USGS                             | U.S. Geologic Survey                                               |
| VFR                              | Visual Flight Rule                                                 |
| WAC                              | Washington Administrative Code                                     |
| WDFW                             | Washington State Department of Fish and Wildlife                   |
| WHMP                             | Wildlife Hazard Management Plan                                    |
| WRIA                             | Water Resource Inventory Area                                      |
| WQC                              | Water Quality Certification                                        |
| WQS                              | Water Quality Standard                                             |
| WSDOT                            | Washington State Department of Transportation                      |

---

## EXECUTIVE SUMMARY

As currently configured, Seattle-Tacoma International Airport (STIA) is unable to efficiently meet existing and future regional air travel demands. In response to growth forecasts for passenger and cargo volumes at STIA, a variety of facility improvements are planned to meet travel demands in the Puget Sound Region and reduce aircraft arrival delays during poor weather. These improvements were developed through a master planning process, then updated to reflect revised growth forecasts for passenger use. Some of the planned improvements will cause unavoidable impacts to wetlands, streams, floodplains, and drainage channels within the project area. This *Natural Resource Mitigation Plan* (NRMP) describes the actions that the Port of Seattle (Port) will implement to mitigate for unavoidable wetland and stream impacts associated with Master Plan Update improvements.

The STIA Master Plan Update improvements will affect wetlands, streams, floodplain, drainage channels, and stormwater in the Miller and Des Moines Creek basins. To construct the projects, fill material would be permanently placed in approximately 980 linear ft of Miller Creek, approximately 5.24 acre-ft of the Miller Creek 100-year floodplain, approximately 18.37 acres of wetland, and about 1,290 linear ft of drainage channels. About 2.05 acres of wetland impact would occur during construction, with these wetlands being restored following construction.<sup>1</sup> In addition, new impervious surfaces will affect stormwater runoff and water quality conditions.

Mitigation is planned for on-site and off-site areas. The on-site mitigation areas are not expected to mitigate impacts to avian species<sup>2</sup> that pose aircraft safety concerns. A critical need of the mitigation projects is to restore wetland and stream buffer functions in a manner that avoids creating new avian wildlife hazards and reduces existing avian wildlife hazards.

Consistent with federal and state mitigation requirements, this plan describes actions the Port will take to:

- Avoid and minimize impacts to wetlands and streams by reducing impact areas. Impact area will be reduced by using retaining walls to minimize fill impacts, locating stormwater detention in uplands, and avoiding wetlands in borrow areas.
- Restore temporary impacts to wetlands caused by project construction, including construction of stormwater management facilities.
- Compensate for the impact by providing in-kind mitigation that replaces ecological functions lost by filling wetlands and streams. Compensatory mitigation will restore and enhance ecological and hydrological functions to over 177 acres<sup>3</sup> of land to be protected with

---

<sup>1</sup> The Port has been asked by Ecology and the Army Corps of Engineers to increase the amount of mitigation for both temporary and permanent impacts that typically last for several years. This increased mitigation at Wetland A17 is included in this plan.

<sup>2</sup> Avian habitat functions will be replaced by creating and restoring wetland habitats at an off-site location in Auburn. Non-avian wildlife using mitigation sites are not a hazard to aircraft safety unless they attract avian predators, or move onto active runways.

<sup>3</sup> Increased mitigation requested by the Corps of Engineers at two on-site locations is reflected in this volume.

restrictive covenants. To comply with Federal Aviation Administration requirements regarding wildlife attractants near airports, off-site mitigation is planned to replace wildlife habitat functions the impacted wetlands currently provide. On-site mitigation is planned to replace the other functions provided by the impacted wetlands.

- About 112 acres of the mitigation occurs on-site, restoring natural wetland and stream conditions to currently developed portions of the Miller and Des Moines Creek basins. Elements of the on-site mitigation will replace the impacts to wetland functions caused by the project and will:
  - Restore and enhance riparian wetlands adjacent to Miller and Des Moines Creeks
  - Restore and enhance salmon habitat
  - Enhance stream buffers
  - Remove existing land uses that are detrimental to adjacent wetlands and streams
  - Protect water quality and stream hydrology
- Over 65 acres of mitigation to replace wildlife habitat function will occur at an off-site mitigation area in Auburn, where existing degraded wetlands and abandoned farmland will be restored to a high quality, diverse wetland ecosystem.

A complete description of the goals and objectives of each mitigation project are described in this report. For each mitigation project, an engineering and landscape design is presented and discussed. This NRMP also provides detailed performance and monitoring standards, which as permit requirements, will be enforced by permitting agencies to assure that the projects are constructed as designed, periodically evaluated for success, and adaptively managed. Monitoring and adaptive management will ensure that the hydrologic and ecological benefits described in the plan are ultimately achieved.

Overall, the Master Plan Update improvements design and mitigation will protect wetlands and aquatic resources following guidance provided by state and federal protocols, including Regulatory Guidance Letter (RGL) 01-1 (ACOE 2001). The substantial mitigation described here compensates for identified impacts to hydrology (peak flow and low flow), water quality, wetlands (temporary, permanent filling, and indirect), and streams. This mitigation prevents cumulative impacts attributable to the proposed actions from occurring.





## 1. INTRODUCTION

In response to growth forecasts for passenger and cargo volumes at Seattle-Tacoma International Airport (STIA), a variety of facility improvements are planned to meet the air transportation needs of the Puget Sound Region and reduce aircraft arrival delays during poor weather. These improvements were developed through a master plan process, then updated to reflect revised growth forecasts for passenger use. The Master Plan Update projects have been planned to minimize impacts to wetlands and streams. However, some of the planned improvements will cause unavoidable impacts to wetlands, streams, floodplains, and drainage channels within the project area. This *Natural Resource Mitigation Plan* (NRMP) describes the mitigation actions that the Port of Seattle (Port) will implement to mitigate potential unavoidable wetland and stream impacts associated with Master Plan Update improvements. Actions taken to mitigate potential stormwater and water quality impacts due to the proposed projects are summarized in this plan (Section 6); and are described in detail in the *Comprehensive Stormwater Management Plan for Seattle-Tacoma International Airport Master Plan Update Improvements* (Parametrix 2000a, 2001a). This NRMP describes actions that will be implemented according to all conditions of the Section 401 Water Quality Certification (WQC) (Ecology 2001a).

The mitigation plan includes two major elements: (1) mitigation actions (described in Sections 1 through 7 of this document), and (2) detailed plan sheets that graphically depict the mitigation design (included as Appendices A-F of this report). Compensatory mitigation has been proposed to occur on approximately 177 acres, with about 112 acres of on-site mitigation within the Miller and Des Moines Creek basins and about 65 acres of off-site mitigation at the Auburn mitigation site. This mitigation plan and the mitigation designs have been revised in response to: (1) comments received on the Public Notice of September 1999 and December 2000 regarding the type and amount of mitigation, and (2) issues raised by the Washington State Department of Ecology (Ecology), the U.S. Fish and Wildlife Service (USFWS), the U.S. Environmental Protection Agency (EPA), the Washington State Department of Fish and Wildlife (WDFW), the City of Auburn, and the U.S. Army Corps of Engineers (ACOE) on previous drafts of the mitigation plan. The plan describes specific actions taken to:

- *Avoid and minimize* impacts to wetlands and streams.
- *Replace wetland functions on-site* to the maximum extent practicable by restoring and enhancing wetlands in the Miller and Des Moines Creek basins, where compatible with airport operations, and where restoration will reduce wildlife attractants near the airport.
- *Enhance and restore stream habitat functions* through buffer restoration and instream habitat enhancement.
- *Restore wetland functions and create new, high quality wetlands off-site* to replace avian habitat functions in compliance with Federal Aviation Administration (FAA) Advisory Circular 150/5200-33.

The compensatory mitigation plan includes both on-site and off-site mitigation projects including:

*On-Site*

- Vacca Farm restoration — Miller Creek channel relocation and enhancement, wetland and floodplain restoration, and buffer enhancement
- Miller Creek instream habitat, wetland, and riparian buffer enhancements
- Restoration of temporary construction impacts
- Replacement of drainage channels adjacent to Miller Creek
- Tyee Valley Golf Course wetland mitigation and Des Moines Creek riparian buffers
- Trust funds for stream restoration projects in the Miller and Des Moines Creek basins
- Riparian wetland and buffer restoration at the Des Moines Way Nursery site

*Off-site*

- Wetland restoration, enhancement, and creation in Auburn

## **1.1 PURPOSE AND NEED FOR THE PROJECT**

As currently configured, STIA is unable to efficiently meet existing and future regional air travel demands. The airfield operates inefficiently during poor weather because it accommodates aircraft in a single arrival stream only. As a result, significant arrival delay occurs during poor weather. Aircraft are either held on the ground in their originating city, slowed en route, or placed in holding patterns to await clearance to land at STIA. These conditions result in inefficient operation of the existing airfield, as described in the Final Environmental Impact Statement (FEIS) and Final Supplemental Environmental Impact Statement (FSEIS) for the Master Plan Update projects (FAA 1996, 1997a).

With or without improvements, airport activity is expected to increase as a result of regional population growth. As aviation demand grows, aircraft operating delay will increase exponentially. The increased passenger, cargo, and aircraft operations will place increasing burdens on the existing terminal and support facilities. Without improvements, the roadway system, terminal space, gates, cargo, and freight processing space would become more inefficient and congested, and the quality of service at STIA would be reduced.

While STIA currently has sufficient operation capability during good weather conditions, the existing runway capabilities cause arrival delays during poor weather. For instance, when weather worsens from Visual Flight Rule (VFR) 1 to VFR 2, average arrival delay increases by more than ten fold (from 1 minute to 11.4 minutes). Delays further worsen when Instrument Flight Rule (IFR) 1/2/3 conditions occur. In these cases, average arrival delay increases more than twenty fold over VFR 1 (from 1 minute to 21.7 minutes). Because these statistics represent averages, some flights experience less delay, while others experience greater delays. The FAA's National Plan of Integrated Airport Systems concludes that when annual average delays exceed 9 minutes, an airport is experiencing severe delay.

Using average aircraft operating costs developed by the FAA, STIA aircraft delays are estimated to cost the airlines about \$42 million annually under 1992 demand levels. When annual aircraft operations reach 425,000, delay costs are anticipated to exceed \$176 million annually. Without the third parallel runway, at this level of activity, average VFR 2 arrival delay would exceed 40 minutes and IFR delay would exceed 70 minutes. A third parallel runway, located 2,500 ft west of the existing 16R/34L runway, would permit staggered dual-stream arrivals in poor weather conditions. It would decrease average arrival delays by about 80 percent compared to taking no action, and result in a savings of \$132 million per year.

Based on this analysis, and as a result of planning for the Master Plan Update improvements, the Puget Sound Regional Commission and other regional officials have identified the following needs for STIA:

- Improve the poor weather airfield operating capability (over 85 percent of total STIA delays are incurred by aircraft arriving during poor weather).
- Provide sufficient runway length to accommodate warm weather operations and payloads for aircraft types operating to the Pacific Rim.
- Provide Runway Safety Areas (RSAs) that meet FAA standards.
- Provide efficient and flexible land-side facilities to accommodate future aviation demand.

## 1.2 PROJECT LOCATION

STIA is located within the City of SeaTac in King County, Washington, situated 12 miles south of downtown Seattle (Sections 20, 21, 28, 29, 32, and 33, Township 23N, Range 4E; and Sections 4 and 5, Township 22N, Range 4E, W.M.) (Figure 1.2-1). On-site mitigation projects are located in the vicinity of STIA, while the off-site mitigation project is located southeast of STIA in the City of Auburn, Washington (Figure 1.2-1).

Mitigation for the Master Plan Update improvements is proposed on land currently owned by the Port within the acquisition area at STIA (Figure 1.2-2) or at the site in Auburn, Washington, which the Port has owned since 1995 (see Figure 1.2-1). The Auburn mitigation site is located on the west side of the Green River and south of South 277<sup>th</sup> Street (SE¼ Section 31, Township 22N, Range 4E, W.M.).

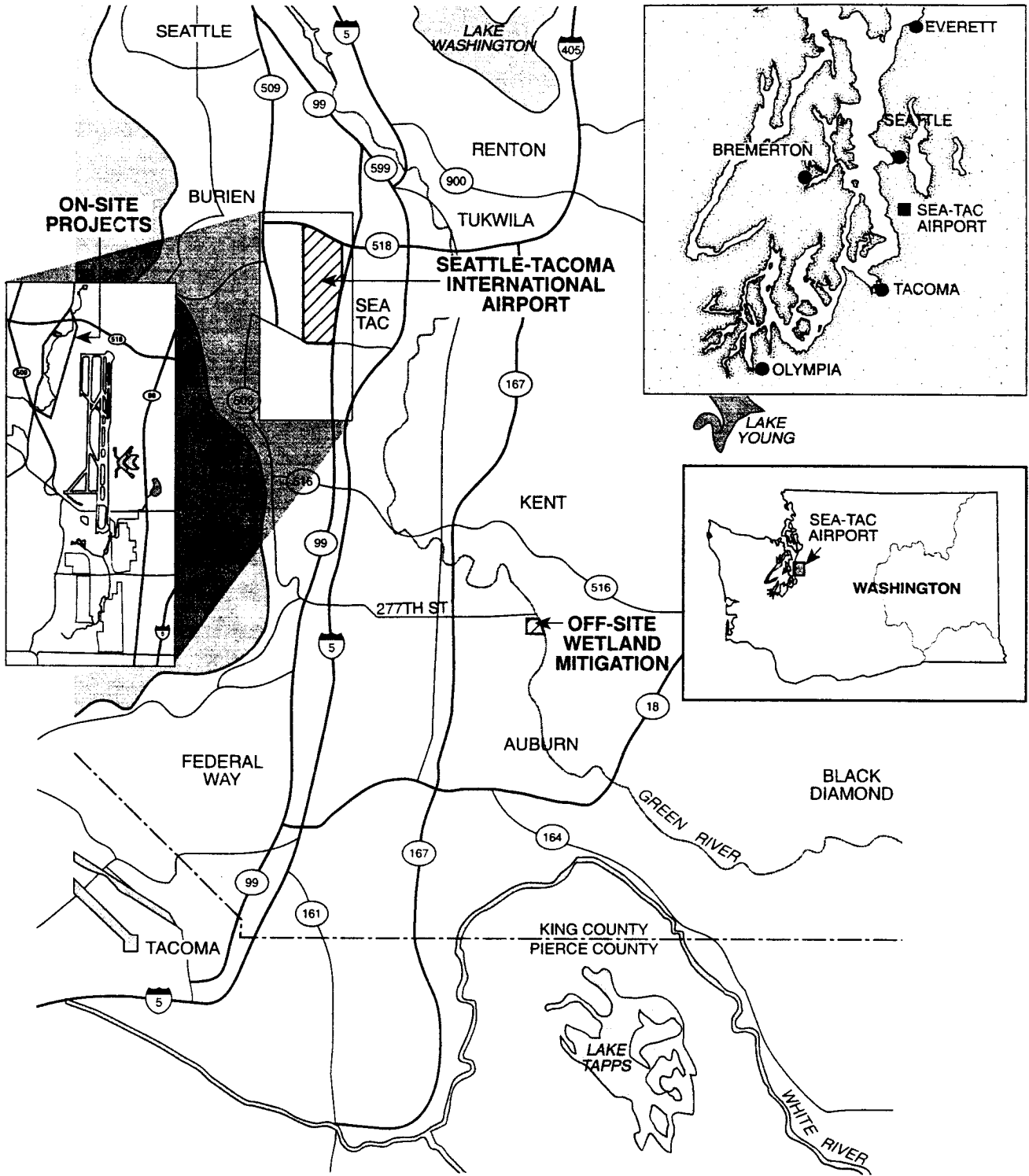
The Port is also proposing to establish two trust funds to be used to support local stream restoration efforts in both the Des Moines and Miller Creek basins. Stream restoration projects may occur on property not owned by the Port.

## 1.3 PROJECT DESCRIPTION

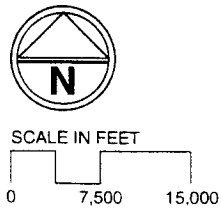
The Master Plan Update improvements include construction activities that will fill approximately 18.37 acres of wetlands in the Miller Creek<sup>4</sup> and Des Moines Creek watersheds. Master Plan

---

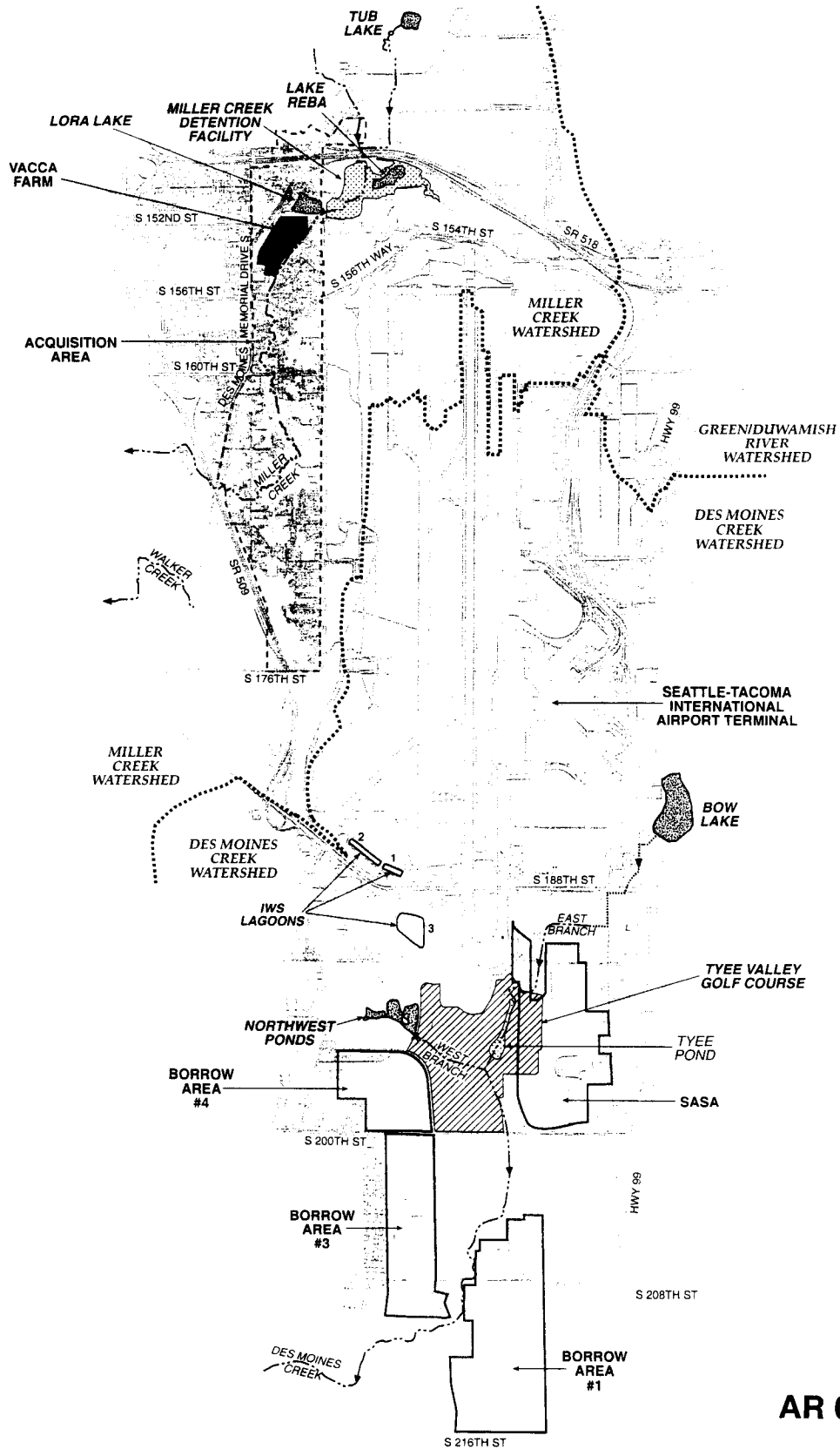
<sup>4</sup> References to Miller Creek watershed include Walker Creek.



Port of Seattle/Natural Resource Mitigation Plan/556-2912-001/01(03) 11/01 (K)

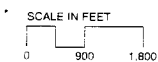


**Figure 1.2-1**  
**Location of Seattle-Tacoma**  
**International Airport and**  
**Off-Site Wetland Mitigation Site**



AR 049036

Port of Seattle Natural Resource Mitigation Plan 556-2912-001/01/03: 11/01 (K)



- Approximate Acquisition Area
- Water Features
- Stream
- Watershed Boundaries
- Detention Facility
- Tyee Valley Golf Course
- Vacca Farm
- Piped Stream

**Figure 1.2-2**  
**Locations of Existing Water Features,**  
**Stormwater Facilities, Watershed**  
**Boundaries, and Acquisition**  
**Area of STIA**

Update improvement projects are summarized in Table 1.3-1. Elements of the project that will result in wetland, floodplain, stream, and drainage channel impacts include the following:

- Adding an 8,500-ft-long third parallel runway (16X/34X) with associated taxiway and navigational aids
- Establishing standard RSAs for existing runways 16R/34L and 16L/34R
- Relocating South 154<sup>th</sup> Street north of the extended RSAs and the new third runway
- Developing the South Aviation Support Area (SASA) for cargo and/or maintenance facilities
- Using on-site borrow sources for the third runway embankment
- Relocating, redeveloping, and expanding support facilities (passenger terminal facilities, stormwater facilities [including outfalls], electrical substations, utility corridors, etc.)

These elements of the project are described more fully below.

**Table 1.3-1. Proposed Master Plan Update improvement projects at Seattle-Tacoma International Airport.**

| Project                                           | Description                                                                                                                                                                                                                                                                                                                       |
|---------------------------------------------------|-----------------------------------------------------------------------------------------------------------------------------------------------------------------------------------------------------------------------------------------------------------------------------------------------------------------------------------|
| <b>Runway and Taxiway Projects</b>                |                                                                                                                                                                                                                                                                                                                                   |
| Property Acquisition, Street and Utility Vacation | Includes purchasing property and demolishing existing structures between existing STIA boundary west to Des Moines Memorial Drive and State Route (SR) 509. Required for third runway embankment fill and construction impact mitigation. Acquisition and demolition is also required for the south runway protection zone (RPZ). |
| Embankment Fill                                   | Embankment for third runway, constructed using imported fill. Approximately 16.5 million cubic yards (cy) will be placed over a 5- to 7-year period. Existing roads and streets under embankment footprint will be removed.                                                                                                       |
| Interconnecting Taxiways                          | New connecting taxiways between existing runway and third runway. Project is located on existing airfield, requiring only minimal grading.                                                                                                                                                                                        |
| Runway 16X/34X                                    | Paving of third runway after completion of embankment fill.                                                                                                                                                                                                                                                                       |
| Extension of Runway 34R by 600 ft                 | Extend runway by 600 ft for improved warm weather and large aircraft operations. Project is located at the southern end of the east runway.                                                                                                                                                                                       |
| Additional Taxiway Exits on 16L/34R               | Construction of new ramps to the existing terminal apron.                                                                                                                                                                                                                                                                         |
| Dual Taxiway 34R                                  | Improvements to taxiways serving the South Aviation Support Area (SASA) and south apron.                                                                                                                                                                                                                                          |
| <b>Borrow Sites</b>                               |                                                                                                                                                                                                                                                                                                                                   |
| Borrow Sites                                      | Sources of fill for third runway embankment, located on STIA property south of the airport. Approximately 6.7 million cy of material will be excavated from three sites and transported across airport property to the embankment.                                                                                                |
| <b>Runway Safety Areas</b>                        |                                                                                                                                                                                                                                                                                                                                   |
| Runway 34R Safety Fill                            | Extend runway safety fill to meet FAA standards.                                                                                                                                                                                                                                                                                  |
| RSAs 16R/16L                                      | Extend safety fills by 1,000 ft to meet FAA standards.                                                                                                                                                                                                                                                                            |
| Relocation of Displaced Threshold on Runway 16L   | Airfield taxiway improvements. The runway threshold (i.e., the emergency landing pad at end of runway pavement) to be relocated onto new RSA.                                                                                                                                                                                     |

**Table 1.3-1. Proposed Master Plan Update improvement projects at Seattle-Tacoma International Airport (continued).**

| <b>Project</b>                                                                                 | <b>Description</b>                                                                                                                                           |
|------------------------------------------------------------------------------------------------|--------------------------------------------------------------------------------------------------------------------------------------------------------------|
| Miller Creek Sewer Relocation                                                                  | Relocate sewer around third runway embankment and runway safety fills. New sewer will run along new alignment of South 154 <sup>th</sup> Street.             |
| <b>FAA Navigation Aids (NAVAIDS)</b>                                                           |                                                                                                                                                              |
| New Airport Traffic Control Tower                                                              | New air traffic control tower will be located in existing developed area near terminal.                                                                      |
| Relocate Airport Surveillance Radar (ASR), Airport Surface Detection Equipment (ASDE), NAVAIDS | Existing radar and navigation equipment will be relocated to allow construction of third runway.                                                             |
| <b>Airfield Building Improvements</b>                                                          |                                                                                                                                                              |
| New Snow Equipment Storage                                                                     | New building to house snow removal equipment.                                                                                                                |
| Weyerhaeuser Hangar Relocation                                                                 | Relocate existing hangar on west side of airfield to allow construction of third runway. New hangar will be located near south end of third runway.          |
| <b>Terminal/Air Cargo Area Improvements</b>                                                    |                                                                                                                                                              |
| Relocation of Airborne Cargo                                                                   | Relocate existing cargo building from air traffic control tower site to north cargo area. Located in existing developed area near terminal.                  |
| Central Terminal Expansion                                                                     | Passenger terminal remodel. Located in existing developed area at terminal.                                                                                  |
| South Terminal Expansion Project (STEP)                                                        | Passenger terminal remodel. Located in existing developed area to the south of the main passenger terminal.                                                  |
| Northwest Hangar Relocation                                                                    | Relocate Northwest Airlines hangar to site now occupied by Delta hangar. Located in existing developed area.                                                 |
| Satellite Transit Shuttle (STS) System Rehabilitation                                          | Remodel and upgrade underground transit system linking terminal to satellites.                                                                               |
| Redevelopment of North Air Cargo                                                               | New or expanded air cargo facilities along Air Cargo Road at north end of airport.                                                                           |
| Expansion of North Unit Terminal (North Pier)                                                  | Addition to new passenger terminal located north of existing terminal. Located in existing developed area (Doug Fox parking lot and airport access freeway). |
| New Airport Rescue and Fire Fighting Facility (ARFF)                                           | Replaces facility displaced by new North Terminal. The new facility will be located to the north of the North Terminal.                                      |
| Cargo Warehouse at 24 <sup>th</sup> Avenue South                                               | New air cargo facility located north of SR 518 on 24 <sup>th</sup> Avenue South.                                                                             |
| Westin Hotel                                                                                   | New hotel located immediately north of main passenger terminal. Located in existing developed area at terminal.                                              |
| <b>Roads<sup>a</sup></b>                                                                       |                                                                                                                                                              |
| Temporary SR 518 and SR 509 Interchanges                                                       | Temporary access ramps to serve construction of third runway embankment and runway safety fill; will be removed after project completion.                    |
| South 154 <sup>th</sup> Street /South 156 <sup>th</sup> Way Relocation                         | Relocate public roadway to allow construction of third runway embankment and runway safety fills. Existing road will be demolished.                          |



**Table 1.3-1. Proposed Master Plan Update improvement projects at Seattle-Tacoma International Airport (continued).**

| <b>Project</b>                                                                 | <b>Description</b>                                                                                                                                                                                                                                                                                                                                                                                                    |
|--------------------------------------------------------------------------------|-----------------------------------------------------------------------------------------------------------------------------------------------------------------------------------------------------------------------------------------------------------------------------------------------------------------------------------------------------------------------------------------------------------------------|
| South 154 <sup>th</sup> Street /South 156 <sup>th</sup> Way Bridge Replacement | Relocate existing South 156th Way bridge over Miller Creek to accommodate the third runway footprint and South 154 <sup>th</sup> Street /South 156 <sup>th</sup> Way relocation. In-water work associated with this project is limited to removal of the existing bridge and bank restoration.                                                                                                                        |
| Improvements to Main Terminal Roads                                            | Transportation circulation, seismic, and other improvements to roadway systems serving terminal.                                                                                                                                                                                                                                                                                                                      |
| Improved Access and Circulation Roadway Improvements                           | Improvements to existing roadway system serving passenger terminal, garage, and air cargo facilities.                                                                                                                                                                                                                                                                                                                 |
| North Unit Terminal Roadways                                                   | Improvements to existing roadway system to serve the new North Terminal and garage.                                                                                                                                                                                                                                                                                                                                   |
| Improvements to South Access Connector Roadway (South Link)                    | Improvements to existing roadway system serving passenger terminal, garage, and air cargo facilities. Will connect terminal and garage area to South Access roadway and SR 509 extension south of airport.                                                                                                                                                                                                            |
| <b>Parking</b>                                                                 |                                                                                                                                                                                                                                                                                                                                                                                                                       |
| Main Parking Garage Expansion                                                  | Expand parking facility at main passenger terminal on north and south sides (existing developed areas), and add floors to portions of existing garage.                                                                                                                                                                                                                                                                |
| North Employee Parking Lot (NEPL), Phase 1                                     | New parking facility for employees, located north of SR 518.                                                                                                                                                                                                                                                                                                                                                          |
| North Unit Parking Structure                                                   | Construction of new garage serving new North Terminal facility. Facility will be located at existing Doug Fox parking lot.                                                                                                                                                                                                                                                                                            |
| <b>The South Aviation Support Area</b>                                         |                                                                                                                                                                                                                                                                                                                                                                                                                       |
| SASA and Access Taxiways                                                       | New airport support facility for cargo and/or maintenance, located at the south end of the airport south of the Olympic Tank Farm and South 188 <sup>th</sup> Street. Airplane access will be by new parallel taxiway constructed along Runway 34R.                                                                                                                                                                   |
| Relocation of Existing Facilities to the SASA                                  | Airport operation support facilities will be relocated to the SASA once SASA site development is completed. Many of these facilities must be relocated from their present locations due to main terminal expansion (i.e., STEP and North Terminal), including northwest hangar, ground support equipment, ground and corporate aviation facilities, new airport maintenance building, and United maintenance complex. |
| <b>Stormwater Facilities<sup>b</sup></b>                                       |                                                                                                                                                                                                                                                                                                                                                                                                                       |
| SASA Detention Pond                                                            | Create regional stormwater detention pond for the SASA project and other sites. Pond is 33.4 acre-ft and discharges to Des Moines Creek.                                                                                                                                                                                                                                                                              |
| NEPL Vault                                                                     | A 13.9 acre-ft vault to retrofit the NEPL; discharges to Miller Creek via Lake Reba.                                                                                                                                                                                                                                                                                                                                  |
| Third Runway Vaults and Ponds                                                  | Stormwater detention vaults and ponds at the north, west, and south sides of the airport, discharging to Miller, Walker, and Des Moines Creeks.                                                                                                                                                                                                                                                                       |
| STIA Retrofit Facilities                                                       | Detention vaults or ponds to provide flow control retrofitting for existing STIA discharges to Des Moines Creek. Vaults to be constructed in combination with third runway facilities when possible.                                                                                                                                                                                                                  |
| Cargo Vault                                                                    | Detention vault for North Cargo Facility (4.5 acre-ft discharging to Miller Creek via Lake Reba).                                                                                                                                                                                                                                                                                                                     |

**Table 1.3-1. Proposed Master Plan Update improvement projects at Seattle-Tacoma International Airport (continued).**

| <b>Project</b>                                  | <b>Description</b>                                                                                                                                                                                                                                                                                                                                                                                                                                                                                                                                                                                                                                                                                                                                                                                                                                                                                                                                                                                                                                                                                                                                                                                                                                                                                                                                                                                                                                                                                                                                                                                           |
|-------------------------------------------------|--------------------------------------------------------------------------------------------------------------------------------------------------------------------------------------------------------------------------------------------------------------------------------------------------------------------------------------------------------------------------------------------------------------------------------------------------------------------------------------------------------------------------------------------------------------------------------------------------------------------------------------------------------------------------------------------------------------------------------------------------------------------------------------------------------------------------------------------------------------------------------------------------------------------------------------------------------------------------------------------------------------------------------------------------------------------------------------------------------------------------------------------------------------------------------------------------------------------------------------------------------------------------------------------------------------------------------------------------------------------------------------------------------------------------------------------------------------------------------------------------------------------------------------------------------------------------------------------------------------|
| <b>Natural Resource Mitigation</b>              |                                                                                                                                                                                                                                                                                                                                                                                                                                                                                                                                                                                                                                                                                                                                                                                                                                                                                                                                                                                                                                                                                                                                                                                                                                                                                                                                                                                                                                                                                                                                                                                                              |
| Miller Creek Relocation                         | Approximately 980 ft of Miller Creek immediately downstream of the Miller Creek detention facility will be relocated to accommodate third runway embankment and runway safety fill.                                                                                                                                                                                                                                                                                                                                                                                                                                                                                                                                                                                                                                                                                                                                                                                                                                                                                                                                                                                                                                                                                                                                                                                                                                                                                                                                                                                                                          |
| Miller Creek Buffer and Wetland Enhancement     | Establish a 100-ft buffer (average) along approximately 6,500 linear ft of Miller Creek and riparian wetlands associated with Miller Creek within the acquisition area. Enhance approximately 10.25 acres of existing wetlands along the stream and protect with 40.86 acres of enhanced wetland buffer.                                                                                                                                                                                                                                                                                                                                                                                                                                                                                                                                                                                                                                                                                                                                                                                                                                                                                                                                                                                                                                                                                                                                                                                                                                                                                                     |
| Miller Creek Floodplain and Wetland Restoration | Excavate approximately 9,600 cy from the Vacca Farm site adjacent to Miller Creek to compensate for approximately 8,500 cy of floodplain fill for third runway embankment and north safety fill. Restore and enhance approximately 19 acres of stream habitat, floodplain wetlands, aquatic habitat in Lora Lake, and buffers at Vacca Farm.                                                                                                                                                                                                                                                                                                                                                                                                                                                                                                                                                                                                                                                                                                                                                                                                                                                                                                                                                                                                                                                                                                                                                                                                                                                                 |
| Miller Creek Instream Habitat Enhancement       | <p>Project 1: South of the Vacca Farm site, approximately 440 ft of channel. Remove rock riprap, footbridges, and trash. Place large woody debris (LWD) throughout this section of the stream. Plant riparian areas along the stream with native wetland and upland plant species.</p> <p>Project 2: Approximately 150 ft upstream of South 160<sup>th</sup> Street, approximately 235 ft of channel. Install LWD in the stream channel, grade a small section of the west bank of the stream to create a gravel bench in the floodplain, remove two rock weirs to improve fish passage, and plant the upland area with native trees and shrubs.</p> <p>Project 3: Immediately downstream of South 160<sup>th</sup> Street, approximately 380 ft of channel. Grade a section of the east bank, remove a rubber-tire bulkhead, and install LWD in the stream and on its banks. Plant buffer areas with native trees and shrubs.</p> <p>Project 4: Miller Creek immediately upstream of 8<sup>th</sup> Avenue South, approximately 420 ft of channel. Grade portions of both banks. Remove footbridges and portions of concrete block walls. Install LWD in the stream and on its banks. Plant buffer areas with native trees and shrubs.</p> <p>In addition to these specific enhancements, debris such as tires, garbage, and fences will be removed throughout the entire stretch of Miller Creek from the Vacca Farm site south to Des Moines Memorial Drive. In areas where access is readily available, LWD will be selectively placed throughout the stream to improve instream habitat conditions.</p> |
| Des Moines Way Nursery                          | Restore 2.2 acres of wetland by removing fill and commercial development from wetlands. Enhance about 0.8 acres of wetland lawn to shrub dominated wetland. Enhance 450 linear feet of Miller Creek. Protect site with about 2.7 acres of restored buffers.                                                                                                                                                                                                                                                                                                                                                                                                                                                                                                                                                                                                                                                                                                                                                                                                                                                                                                                                                                                                                                                                                                                                                                                                                                                                                                                                                  |
| Drainage Channels Relocation                    | Relocate a minimum of 1,290 linear ft of drainage channels to accommodate the third runway embankment. Plant buffers along the drainage channels with native grass and shrubs.                                                                                                                                                                                                                                                                                                                                                                                                                                                                                                                                                                                                                                                                                                                                                                                                                                                                                                                                                                                                                                                                                                                                                                                                                                                                                                                                                                                                                               |
| Restoration of Temporarily Impacted Wetlands    | Approximately 2.05 acres of wetland located west of the third runway embankment, north of relocated South 154 <sup>th</sup> Street, and west of the Miller Creek relocation project, will be temporarily filled or disturbed during embankment construction. When construction activities are completed, remove fill material, restore pre-disturbance topography, and plant wetlands with native shrub vegetation.                                                                                                                                                                                                                                                                                                                                                                                                                                                                                                                                                                                                                                                                                                                                                                                                                                                                                                                                                                                                                                                                                                                                                                                          |

**Table 1.3-1. Proposed Master Plan Update improvement projects at Seattle-Tacoma International Airport (continued).**

| <b>Project</b>                                                                       | <b>Description</b>                                                                                                                                                                                                                                                                                                                                                                                                                                                                                                                                                                            |
|--------------------------------------------------------------------------------------|-----------------------------------------------------------------------------------------------------------------------------------------------------------------------------------------------------------------------------------------------------------------------------------------------------------------------------------------------------------------------------------------------------------------------------------------------------------------------------------------------------------------------------------------------------------------------------------------------|
| Tyee Valley Golf Course Wetlands Enhancement and Des Moines Creek Buffer Enhancement | Restore approximately 4.5 acres of emergent wetland area and approximately 1.6 acres of buffer located within Tyee Valley Golf Course to a native shrub vegetation community. The enhancement actions will be integrated into plans to construct a regional detention facility (RDF) on the golf course (King County Capital Improvement Project Design Team 1999). The enhancement will convert the existing turf wetland to native shrub wetland community.<br><br>Enhance approximately 3.4 acres (average 100 ft wide) of buffer and 1.0 acre of existing wetland along Des Moines Creek. |
| Wetland Habitat (including Avian Habitat) near the Green River in Auburn             | Restore wetland functions to a 65-acre parcel near the Green River in the City of Auburn. Create and/or restore approximately 17.2 acres of forest, 6.0 acres of shrub, 6.2 acres of emergent, and 0.60 acre of open-water wetland.<br>Enhance protective buffers totaling about 15.90 acres.                                                                                                                                                                                                                                                                                                 |

<sup>a</sup> Temporary roads used to haul fill material from three on-site borrow areas to construction sites are included in the analysis of the borrow areas and not listed here.

<sup>b</sup> Des Moines Creek Basin Plan Committee will construct an RDF on the Tyee Golf Course to provide regional flow control. This project will eliminate the need for STIA retrofit facilities described above. As this is a cumulative action subject to future federal action, it is not a Master Plan Update improvement.

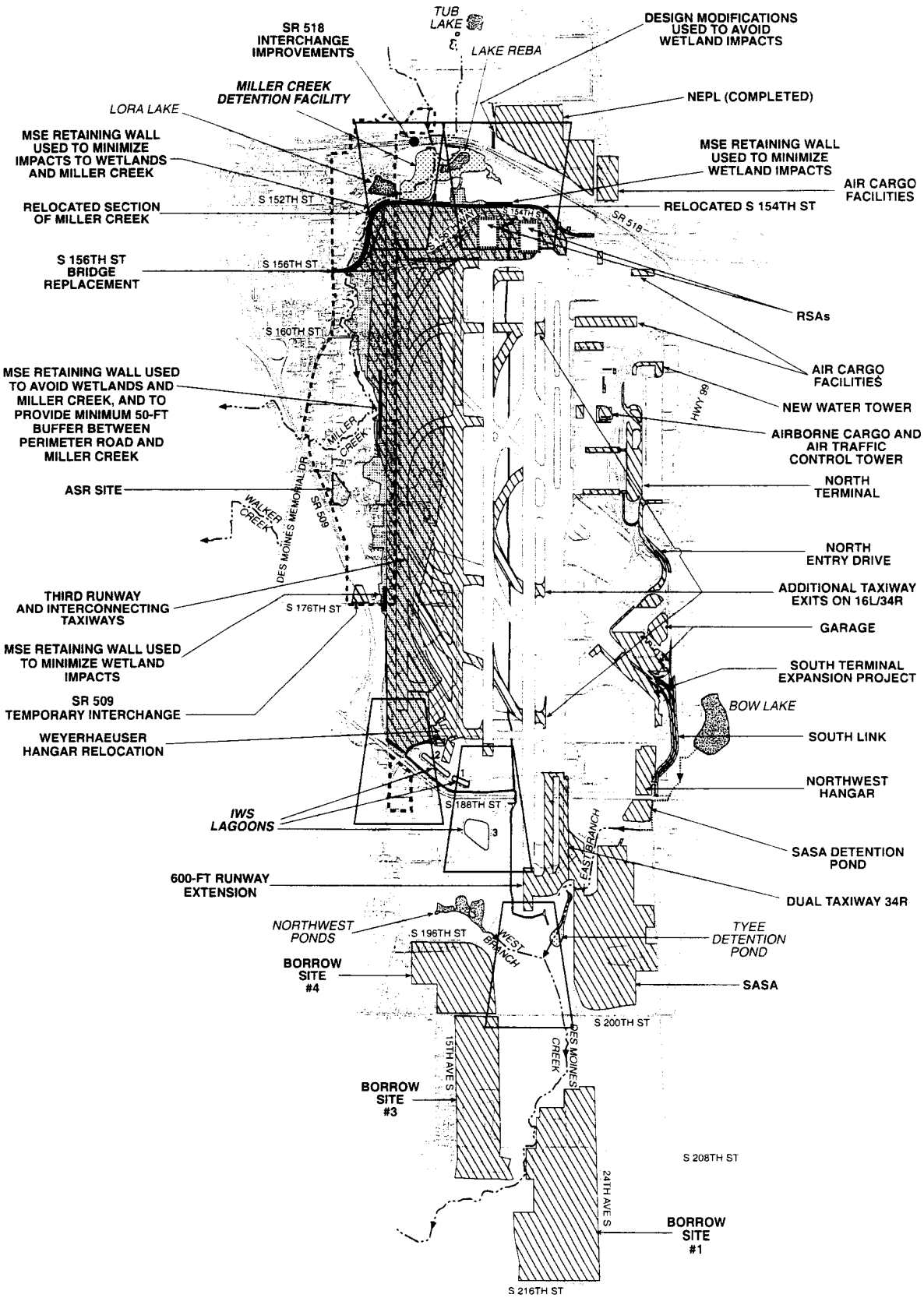
### **1.3.1 Runways and Taxiways**

To overcome aircraft arrival congestion during poor weather conditions, the Port proposes to build a new 8,500-ft runway on approximately 16.5 million cy of fill on the west side of the existing STIA airfield (Figure 1.3-1). The existing airfield plateau will be extended west over 12<sup>th</sup> Avenue South. The current location of 12<sup>th</sup> Avenue South will be the approximate centerline of the new runway. To construct the third runway and extend the airfield plateau, a large embankment with four mechanically stabilized earth (MSE) retaining walls will be constructed. The MSE retaining walls are located at the northern, central, and southern portions of the embankment (see Figure 1.3-1), and have been designed to avoid and minimize direct impacts from the embankment to Miller Creek and associated wetlands. Security and emergency access roads will be constructed around the runway perimeter. New and relocated interconnecting taxiways will also be constructed.

To accommodate the third runway embankment, stormwater management facilities, and a neighborhood noise abatement area, the Port has purchased land west of the existing runway. Most of this land consists of private residences. In this report, this area is referred to as the “acquisition area.” The acquisition area is generally bounded by SR 518 to the north, South 176<sup>th</sup> Street to the south, Des Moines Memorial Drive to the west, and 12<sup>th</sup> Avenue South to the east (see Figure 1.3-1). Several parcels in and adjacent to the acquisition area are voluntary acquisitions and may or may not be acquired by the Port. However, no additional action, other than demolitions, will be taken in the voluntary acquisition areas. At the north end of the third runway, South 154<sup>th</sup> Street will be relocated to accommodate the new runway (see below).

### **1.3.2 Runway Safety Area Extensions / South 154<sup>th</sup> Street Relocation**

RSA extensions are necessary for the existing runways and the new third runway to ensure that they meet current FAA standards. The RSA extensions are to be created at the north end of the existing airport runways south of SR 518, and at the southern end of the new third runway. The RSA



AR 049042

Port of Seattle/Natural Resource Mitigation Plan/556-2912-001 01/03 11-01 (K)

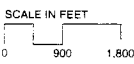
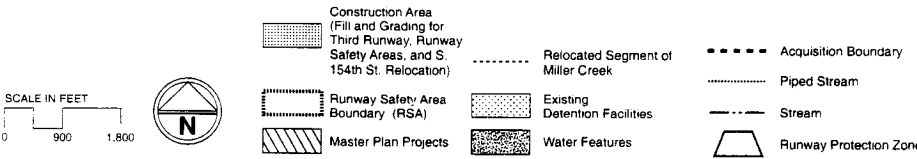


Figure 1.3-1 Master Plan Update Improvement Projects at STIA

extensions at the north end of the two existing runways, as well as the new third runway construction, will require relocating South 154<sup>th</sup> Street (Figure 1.3-2). The relocated road section will be located approximately 55 to 650 ft north of the current alignment. The new alignment will be north and west of the third runway embankment, connecting with South 156<sup>th</sup> Way at Des Moines Memorial Drive. In addition, a portion of an existing sewer line will be relocated to parallel the new road alignment.

South 156<sup>th</sup> Way currently crosses over Miller Creek on an existing timber bridge. The existing bridge will be replaced with a new bridge that spans the stream and floodplain of Miller Creek as part of the South 154<sup>th</sup> Street relocation (see Figure 1.3-2).

A MSE retaining wall will be constructed along the north side of the relocated road to minimize filling of the forested wetlands located north of the roadway (see Figure 1.3-2). The MSE wall at this location will extend up to approximately 50 ft in height.

### **1.3.3 The South Aviation Support Area**

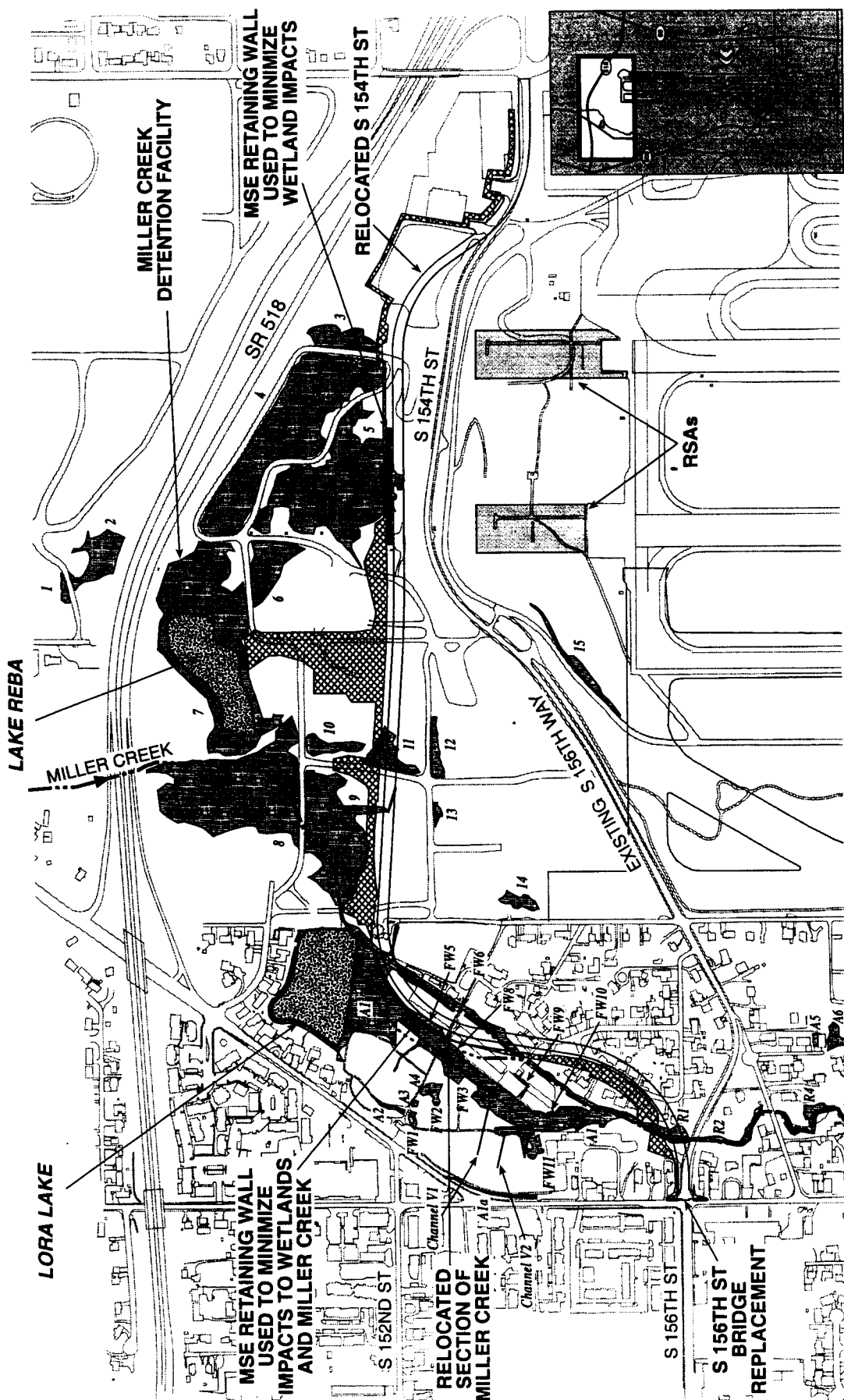
The SASA (see Figure 1.3-1) will provide space for aircraft maintenance/support and air cargo facilities. The FEIS for the Master Plan Update improvements identified several existing uses that would be moved to the SASA, primarily due to the expansion of the Main Terminal. These uses include Northwest Airlines' aircraft maintenance and hangar, the U.S. Post Office airmail facility, and possibly Airborne cargo. The SASA will also allow air cargo and aircraft maintenance facilities of airlines and other tenants to be expanded. The SASA facility will accommodate:

- Relocated line maintenance and cargo facilities that must be moved prior to expansion of passenger terminal facilities
- Line maintenance requirements
- Aircraft maintenance facilities in response to existing and/or future market demands
- Expansion of cargo handling and maintenance capabilities
- Other aircraft support facilities

### **1.3.4 On-Site Borrow Source Areas**

On-site borrow areas are proposed to be excavated as a source of fill to be used to construct portions of the runway embankment. Three on-site borrow areas are located on airport property between 24<sup>th</sup> Avenue South and 15<sup>th</sup> Avenue South, and between South 196<sup>th</sup> and South 216<sup>th</sup> Streets (see Figure 1.3-1). These borrow areas are planned to supply approximately 6.7 million cy of fill material. Current engineering estimates suggest that Borrow Site 1 will supply up to 4.2 million cy, and Borrow Sites 3 and 4 will supply 2.5 million cy.

An additional 2.4 million cy is available from on-site sources within the third runway footprint. This fill material will be obtained through excavation at the south end of the third runway, where materials are stockpiled and where the existing ground elevation is above the final grade for the runway. The fill material from these sources has been tested for structural integrity and found to be suitable for use in the RSAs and portions of the infield.



Port of Seattle/Natural Resource Mitigation Plan/556-2912-001/01(03) 11/01 (K)

**SCALE IN FEET**

0 300 600

**Legend:**

- Delineated Wetlands Verified by ACOE
- Water Features
- Stream
- Location of Temporary Construction Impacts
- North Arrow
- A5 Wetland Number

**Figure 1.3-2**  
**Existing and Relocated**  
**South 154th/156th Street**

### **1.3.5 Other Support Facilities**

Stormwater, electrical, water, sewer, and other utilities must be provided to new or reconstructed airport facilities. Utilities that will result in unavoidable wetland impacts include the placement of stormwater detention facilities for the runway embankment, relocation of a sewer line, and the SASA detention pond. These wetland impacts are discussed in more detail in Section 3 of this report, and in the *Wetland Functional Assessment and Impact Analysis Master Plan Update Improvements Seattle-Tacoma International Airport* (Parametrix 2001b).

### **1.4 RESPONSIBLE PARTIES**

The Port is the applicant and owner of this project. The name and phone number of the Port representative in charge of environmental permitting and compliance for the project is: Ms. Elizabeth Leavitt, Manager-Aviation Environmental Programs; Port of Seattle; P.O. Box 68727; Seattle, WA 98168-0727; (206) 433-7203.

### **1.5 DOCUMENT ORGANIZATION**

The organization of this document is based on the *Guidelines for Developing Freshwater Wetlands Mitigation Plans and Proposals* (Ecology 1994a). Following the introduction to the project and mitigation actions in Section 1, Section 2 describes existing ecological conditions, and in particular, existing conditions of wetlands and streams within the project area. Section 3 summarizes the direct and indirect impacts of the project to wetlands and other Waters of the U.S. (described in detail in Parametrix 2001b).

Section 4 summarizes the overall mitigation plan and the mitigation monitoring plan. The mitigation sequencing approach and specific mitigation projects are summarized. The overall monitoring approach, methods, and schedules required to assure the ecological benefits of the mitigation are summarized. The adaptive management approach that will be used to implement maintenance and contingency measures at the mitigation sites is also described. Section 4 also describes the integrated weed management strategy that will be used to control invasive non-native species. Finally, Section 4 summarizes the relationship between the *Wildlife Hazard Management Plan* (WHMP) for controlling wildlife hazards near the airport, and each mitigation project.

Section 5 provides detailed mitigation plans, performance standards, monitoring approach, and implementation schedules for the on-site mitigation in the Miller and Des Moines Creek basins. Section 5 also describes mitigation to replace functions of drainage channels, mitigation for temporary construction impacts, and monitoring of wetlands adjacent to the construction projects. On-site mitigation at the Des Moines Way Nursery site is described in Appendix N. Appendices A through F provide detailed engineering drawings of each mitigation project. Other appendices (Appendices G through Q) provide various detailed supporting information requested by agency staff.

The *Comprehensive Stormwater Management Plan* that is proposed to avoid, minimize, and mitigate impacts to water quantity and/or quality in Miller and Des Moines Creeks is summarized in Section 6. Section 7 describes the mitigation plans, performance standards, monitoring approach, and schedules for the off-site wetland mitigation in Auburn.





## 2. EXISTING CONDITIONS IN THE PROJECT AREA

This section describes the wetlands, streams, floodplains, and drainage channels in areas that will be temporarily or permanently impacted as a result of Master Plan Update improvements. The wetlands within the project area are described in detail in the *Wetland Delineation Report Master Plan Update Improvements Seattle-Tacoma International Airport* (Parametrix 2000b) and the *Wetland Functional Assessment and Impact Analysis* (Parametrix 2001b). Additional detailed information on species listed under the Endangered Species Act (ESA) is provided in the *Biological Assessment Master Plan Update Improvements Seattle-Tacoma International Airport* (Parametrix 2000c). Additional detailed information on existing ecological conditions relevant to the mitigation design at each site is included with the descriptions of each mitigation project in Sections 5 and 7.

### 2.1 WETLANDS

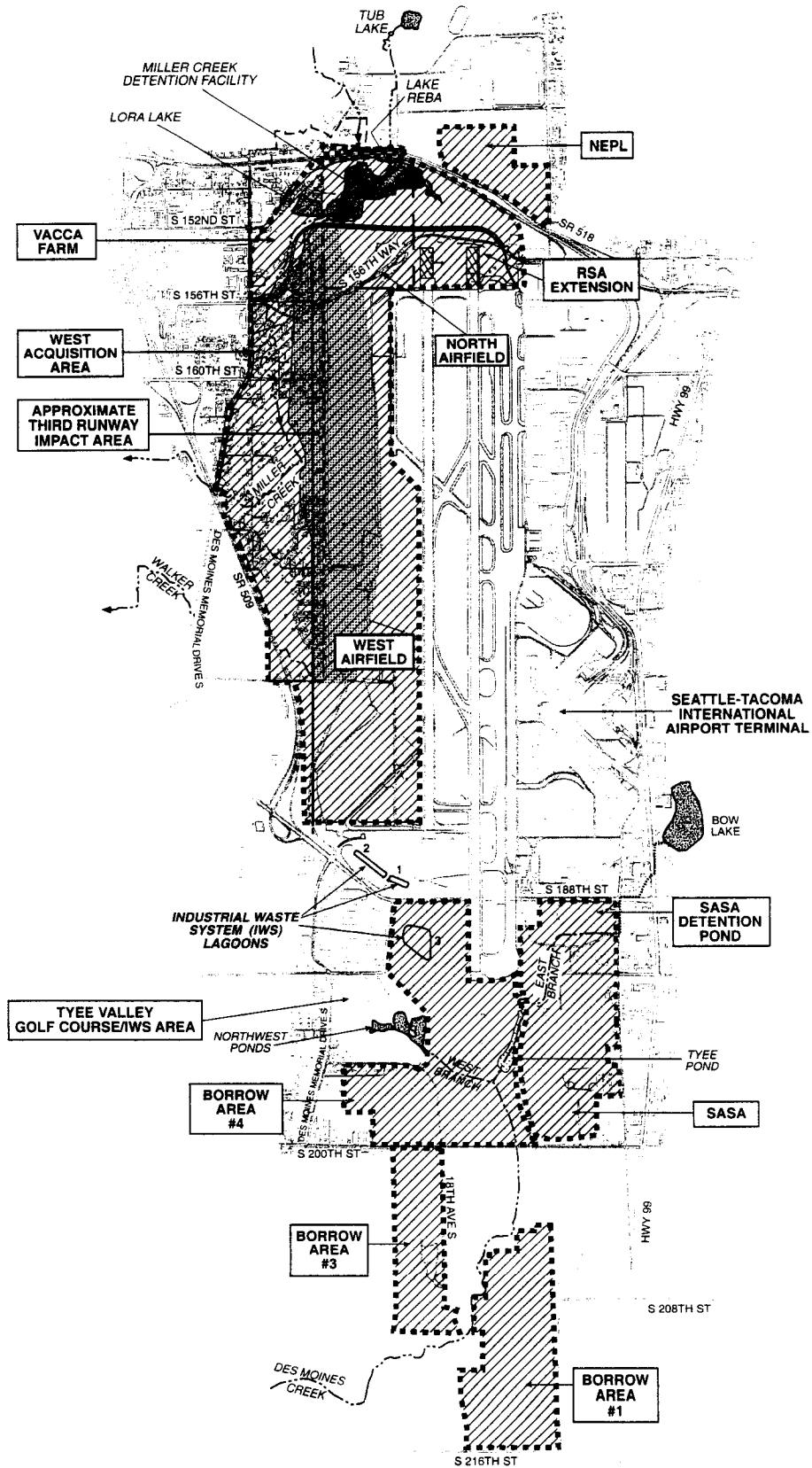
Wetland delineations have been completed throughout the project area (FAA 1996; Parametrix 2000b). ACOE has verified the wetland delineations on all properties within the acquisition area, with the exception of parcels containing Wetland A20 (ACOE 2000).

#### 2.1.1 Wetland Delineation Methodology

Parametrix staff completed field investigations to identify and delineate wetlands in the acquisition area between March 1998 and November 2000. During these site visits, they inspected the project area (Figure 2.1-1) for wetland characteristics and related drainage features. Project staff identified and delineated wetlands in the project area using the Routine Determination Method outlined in the *Washington State Wetland Identification and Delineation Manual* (Ecology 1997) and the *U.S. Army Corps of Engineers Wetland Delineation Manual* (Environmental Laboratory 1987). The delineation methodology incorporated the following regulatory guidance letters and memoranda: ACOE Regulatory Guidance Letters 82-2, 86-9, and 90-7 (ACOE 1982, 1986, 1990); 3-92 Memorandum (ACOE 1992); 5-94 Public Notice (ACOE 1994); Ecology, 3/95 Public Notice (Ecology 1995).

To be considered a wetland, under normal circumstances, an area must have hydrophytic (wetland) vegetation, hydric soils, and wetland hydrology (Ecology 1997; Environmental Laboratory 1987). Areas that do not exhibit indicators for one or more of these three parameters are generally not regulated wetlands. However, in some cases when normal circumstances do not hold, all three parameters may not be present. Additional evaluations were completed to identify wetlands in disturbed and farmed areas (Parametrix 2000b).

ACOE made site visits to confirm wetland identifications and boundary delineations between July 1998 and November 2000. Modifications to delineated wetland boundaries that were requested by ACOE during those site visits have been made and are reflected in the mapping and analysis presented in this report. A summary of all the wetlands identified in the study area is presented in Table 2.1-1.



AR 049048

Port of Seattle/Natural Resource Mitigation Plan/556-2912-001/01(03) 11/01 (K)

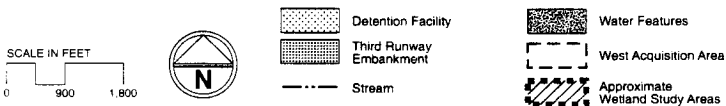


Figure 2.1-1  
Wetland Study Area for the  
Master Plan Update at STIA

**Table 2.1-1. Summary of wetland and other Waters of the U.S. areas in the Seattle-Tacoma International Airport Master Plan Update Area.**

| Wetland <sup>a</sup>                                            | Classification <sup>b</sup>            | Area (Acres) | Drainage Basin |
|-----------------------------------------------------------------|----------------------------------------|--------------|----------------|
| <b>North Employee Parking Lot /Des Moines Way Nursery Areas</b> |                                        |              |                |
| 1                                                               | Forest                                 | 0.07         | Miller         |
| 2                                                               | Forest                                 | 0.73         | Miller         |
| N8, N9, N10                                                     | Emergent, Forest (90/10)               | 0.86         | Miller         |
|                                                                 | <b>Subtotal</b>                        | <b>1.66</b>  |                |
| <b>Runway Safety Area Extension</b>                             |                                        |              |                |
| 3                                                               | Forest                                 | 0.56         | Miller         |
| 4                                                               | Forest                                 | 5.00         | Miller         |
| 5                                                               | Forest/Scrub-Shrub (70/30)             | 4.63         | Miller         |
| 6                                                               | Scrub-Shrub                            | 0.86         | Miller         |
|                                                                 | <b>Subtotal</b>                        | <b>11.05</b> |                |
| <b>Third Runway Project Area</b>                                |                                        |              |                |
| North Airfield                                                  |                                        |              |                |
| 7 <sup>c</sup>                                                  | Forest/Open Water/Emergent (30/50/20)  | 6.68         | Miller         |
| 8                                                               | Scrub-Shrub/Emergent (80/20)           | 4.95         | Miller         |
| 9                                                               | Forest/ Emergent (40/60)               | 2.83         | Miller         |
| 10                                                              | Scrub-Shrub                            | 0.31         | Miller         |
| 11                                                              | Forest/Emergent (80/20)                | 0.50         | Miller         |
| 12                                                              | Forest/Emergent (20/80)                | 0.21         | Miller         |
| 13                                                              | Emergent                               | 0.05         | Miller         |
| 14                                                              | Forest                                 | 0.19         | Miller         |
| West Airfield                                                   |                                        |              |                |
| 15                                                              | Emergent                               | 0.28         | Miller         |
| 16                                                              | Emergent                               | 0.05         | Miller         |
| 17                                                              | Emergent                               | 0.02         | Miller         |
| 18                                                              | Forest/Scrub-Shrub/Emergent (50/20/30) | 3.56         | Miller         |
| 19                                                              | Forest                                 | 0.56         | Miller         |
| 20                                                              | Scrub-Shrub/Emergent (90/10)           | 0.57         | Miller         |
| 21                                                              | Forest                                 | 0.22         | Miller         |
| 22                                                              | Scrub-Shrub/Emergent (90/10)           | 0.06         | Miller         |
| 23                                                              | Emergent                               | 0.77         | Miller         |
| 24                                                              | Emergent                               | 0.14         | Miller         |
| 25                                                              | Forest                                 | 0.06         | Miller         |
| 26                                                              | Emergent                               | 0.02         | Miller         |
| W1                                                              | Emergent                               | 0.10         | Miller         |
| W2                                                              | Forest/Emergent (20/80)                | 0.22         | Miller         |
|                                                                 | Other Waters of the U.S.               | 0.02         | Miller         |
| Vacca Farm Site                                                 |                                        |              |                |
| FW1                                                             | Farmed Wetland                         | 0.03         | Miller         |

**Table 2.1-1. Summary of wetland and other Waters of the U.S. areas in the Seattle-Tacoma International Airport Master Plan Update Area (continued).**

| <b>Wetland <sup>a</sup></b>  | <b>Classification <sup>b</sup></b>     | <b>Area (Acres)</b> | <b>Drainage Basin</b> |
|------------------------------|----------------------------------------|---------------------|-----------------------|
| FW2                          | Farmed Wetland                         | 0.09                | Miller                |
| FW3                          | Farmed Wetland                         | 0.59                | Miller                |
| FW5                          | Farmed Wetland                         | 0.08                | Miller                |
| FW6                          | Farmed Wetland                         | 0.07                | Miller                |
| FW8                          | Farmed Wetland                         | 0.03                | Miller                |
| FW9                          | Farmed Wetland                         | 0.01                | Miller                |
| FW10                         | Farmed Wetland                         | 0.02                | Miller                |
| FW11                         | Farmed Wetland                         | 0.11                | Miller                |
| A1a                          | Shrub                                  | 0.07                | Miller                |
|                              | Other Waters of the U.S.               | 0.02                | Miller                |
| <b>West Acquisition Area</b> |                                        |                     |                       |
| 35a-d                        | Forest/Emergent (40/60)                | 0.67                | Miller                |
| 37a-f                        | Forest/Emergent (70/30)                | 5.73                | Miller                |
| 39                           | Forest/Scrub-Shrub/Emergent (25/50/25) | 0.90                | Miller                |
| 40                           | Scrub-Shrub                            | 0.03                | Miller                |
| 41a and b                    | Emergent/Open Water (60/40)            | 0.44                | Miller                |
| 44a and b                    | Forest/Scrub-Shrub (70/30)             | 3.08                | Miller                |
| A1                           | Forest/Scrub-Shrub/Emergent (15/15/70) | 4.59                | Miller                |
| A2                           | Scrub-Shrub                            | 0.05                | Miller                |
| A3                           | Scrub-Shrub                            | 0.01                | Miller                |
| A4                           | Scrub-Shrub                            | 0.03                | Miller                |
| A5                           | Emergent                               | 0.03                | Miller                |
| A6                           | Forest                                 | 0.16                | Miller                |
| A7                           | Forest                                 | 0.30                | Miller                |
| A8                           | Forest/Scrub-Shrub (30/70)             | 0.38                | Miller                |
| A9                           | Scrub-Shrub                            | 0.04                | Miller                |
| A10                          | Scrub-Shrub                            | 0.01                | Miller                |
| A11                          | Scrub-Shrub                            | 0.02                | Miller                |
| A12                          | Scrub-Shrub                            | 0.11                | Miller                |
| A13                          | Forest                                 | 0.12                | Miller                |
| A14a and b                   | Forest/Scrub-Shrub/Emergent (50/25/25) | 0.19                | Miller                |
| A15                          | Emergent                               | 0.04                | Miller                |
| A16                          | Scrub-Shrub/Emergent (20/80)           | 0.09                | Miller                |
| A17                          | Forest/Scrub-Shrub/Emergent (10/20/70) | 2.66                | Miller                |
| A18                          | Scrub-Shrub                            | 0.01                | Miller                |
| A19                          | Emergent                               | 0.04                | Miller                |
| Lora Lake                    | Open Water                             | 3.06                | Miller                |
|                              | Other Waters of the U.S.               | 0.33                | Miller                |
| <b>Riparian Wetlands</b>     |                                        |                     |                       |
| R1                           | Emergent                               | 0.17                | Miller                |
| R2                           | Scrub-Shrub/Emergent (70/30)           | 0.12                | Miller                |
| R3                           | Scrub-Shrub                            | 0.02                | Miller                |

**Table 2.1-1. Summary of wetland and other Waters of the U.S. areas in the Seattle-Tacoma International Airport Master Plan Update Area (continued).**

| <b>Wetland <sup>a</sup></b> | <b>Classification <sup>b</sup></b>     | <b>Area (Acres)</b> | <b>Drainage Basin</b> |
|-----------------------------|----------------------------------------|---------------------|-----------------------|
| R4                          | Emergent                               | 0.11                | Miller                |
| R4b                         | Forest/Emergent (25/75)                | 0.11                | Miller                |
| R5                          | Emergent                               | 0.05                | Miller                |
| R5b                         | Forest/Emergent (25/75)                | 0.07                | Miller                |
| R6                          | Forest/Emergent (25/75)                | 0.21                | Miller                |
| R6b                         | Emergent                               | 0.09                | Miller                |
| R7                          | Forest/Emergent (25/75)                | 0.04                | Miller                |
| R7a                         | Emergent                               | 0.04                | Miller                |
| R8                          | Scrub-Shrub/Emergent (40/60)           | 0.40                | Miller                |
| R9                          | Forest                                 | 0.38                | Miller                |
| R9a                         | Forest/Scrub-Shrub/Emergent (25/50/25) | 0.74                | Miller                |
| R10                         | Scrub-Shrub                            | 0.04                | Miller                |
| R11                         | Emergent                               | 0.42                | Miller                |
| R12                         | Forest                                 | 0.03                | Miller                |
| R13                         | Emergent                               | 0.12                | Miller                |
| R14a                        | Scrub-Shrub/Emergent (25/75)           | 0.13                | Miller                |
| R14b                        | Emergent                               | 0.08                | Miller                |
| R15a                        | Forest/Scrub-Shrub/Emergent (25/65/10) | 0.79                | Miller                |
| R15b                        | Forest/Emergent (25/75)                | 0.25                | Miller                |
| R17                         | Forest                                 | 0.31                | Miller                |
|                             | <b>Subtotal</b>                        | <b>51.33</b>        |                       |
| <b>Borrow Area 1</b>        |                                        |                     |                       |
| 32                          | Emergent                               | 0.09                | Des Moines            |
| 48                          | Forest/Emergent (20/80)                | 1.58                | Des Moines            |
| B1                          | Forest/Scrub-Shrub (30/70)             | 0.27                | Des Moines            |
| B4                          | Scrub-Shrub                            | 0.07                | Des Moines            |
| B11                         | Emergent                               | 0.18                | Des Moines            |
| B12 <sup>d</sup>            | Scrub-Shrub                            | 0.63                | Des Moines            |
| B14                         | Scrub-Shrub/Emergent (70/30)           | 0.78                | Des Moines            |
| B15 a and b <sup>d</sup>    | Scrub-Shrub                            | 2.05                | Des Moines            |
|                             | Other Waters of U.S.                   | 0.01                | Des Moines            |
|                             | <b>Subtotal</b>                        | <b>5.66</b>         |                       |
| <b>Borrow Area 3</b>        |                                        |                     |                       |
| 29                          | Forest                                 | 0.74                | Des Moines            |
| 30                          | Forest/Scrub-Shrub (80/20)             | 0.88                | Des Moines            |
| B5                          | Forest/Scrub-Shrub (40/60)             | 0.08                | Des Moines            |
| B6                          | Forest/Scrub-Shrub (30/70)             | 0.55                | Des Moines            |
| B7                          | Forest/Scrub-Shrub (30/70)             | 0.03                | Des Moines            |
| B9                          | Forest                                 | 0.05                | Des Moines            |
| B10                         | Forest                                 | 0.02                | Des Moines            |
|                             | <b>Subtotal</b>                        | <b>2.35</b>         |                       |

**Table 2.1-1. Summary of wetland and other Waters of the U.S. areas in the Seattle-Tacoma International Airport Master Plan Update Area (continued).**

| Wetland <sup>a</sup>                                              | Classification <sup>b</sup>                | Area (Acres)  | Drainage Basin |
|-------------------------------------------------------------------|--------------------------------------------|---------------|----------------|
| <b>South Aviation Support Area (SASA)/Tyee Valley Golf Course</b> |                                            |               |                |
| 28 <sup>d</sup>                                                   | Scrub-Shrub/Emergent/Open Water (50/30/20) | 35.45         | Des Moines     |
| 52                                                                | Forest/Scrub-Shrub/Emergent (80/10/10)     | 4.70          | Des Moines     |
| 53                                                                | Forest                                     | 0.60          | Des Moines     |
| G1                                                                | Emergent                                   | 0.05          | Des Moines     |
| G2                                                                | Emergent                                   | 0.02          | Des Moines     |
| G3                                                                | Emergent                                   | 0.06          | Des Moines     |
| G4                                                                | Emergent                                   | 0.04          | Des Moines     |
| G5                                                                | Emergent                                   | 0.87          | Des Moines     |
| G6                                                                | Emergent                                   | 0.01          | Des Moines     |
| G7                                                                | Forest/Scrub-Shrub (30/70)                 | 0.50          | Des Moines     |
| G8                                                                | Emergent                                   | 0.04          | Des Moines     |
| WH                                                                | Open Water                                 | 0.25          | Des Moines     |
| DMC                                                               | Forest/Scrub-Shrub/Emergent (15-15-70)     | 1.08          | Des Moines     |
|                                                                   | <b>Subtotal</b>                            | <b>43.67</b>  |                |
| <b>Industrial Waste System (IWS) Area</b>                         |                                            |               |                |
| IWS a and b                                                       | Forest                                     | 0.67          | Des Moines     |
|                                                                   | <b>Subtotal</b>                            | <b>0.67</b>   |                |
| <b>South Aviation Support Area Detention Pond</b>                 |                                            |               |                |
| E1                                                                | Forest                                     | 0.23          | Des Moines     |
| E2                                                                | Forest                                     | 0.04          | Des Moines     |
| E3                                                                | Forest                                     | 0.06          | Des Moines     |
|                                                                   | <b>Subtotal</b>                            | <b>0.33</b>   | Des Moines     |
| <b>TOTAL</b>                                                      |                                            | <b>116.72</b> |                |

<sup>a</sup> Wetlands are labeled according to the following protocol:

- Wetlands without a letter designation (e.g., Wetland 35 ) were described by Shapiro and Associates, Inc. (FAA 1995).
- Wetlands with an 'A' designation (e.g., Wetland A5) are wetlands occurring within the west acquisition area.
- Wetlands with an 'N' designation (e.g., Wetland N8) occur north of SR 518.
- Wetlands with an 'R' designation (e.g., Wetland R) are riparian wetlands occurring within the west acquisition area.
- Wetlands with a 'W' designation (e.g., Wetland W1) are wetlands occurring within the west airfield area.
- Wetlands with a 'G' designation (e.g., Wetland G5) are wetlands occurring within the Tyee Valley Golf Course or the SASA areas.
- Wetlands with an 'E' designation (e.g., Wetland E1) are wetlands occurring within the SASA detention pond area.
- Wetlands with an 'IWS' designation (e.g., IWSa) are wetlands occurring near the IWS lagoon.
- Wetlands with a 'B' designation (e.g., Wetland B5) are wetlands occurring within the borrow sites.
- Wetland numbers followed by a small case letter designate subsections of a larger wetland (i.e., Wetland 35a) where constructed features (i.e., driveways) fragment a larger wetland.

<sup>b</sup> Numbers indicate approximate percentage of cover by respective wetland classes (Cowardin et al. 1979).

<sup>c</sup> This area includes Lake Reba.

<sup>d</sup> Portions of the wetland area are estimated.

## **2.1.2 Wetland Descriptions**

About 120 wetlands totaling about 117 acres were identified<sup>5</sup> within the study area in the Miller and Des Moines Creek basins (see Table 2.1-1; Figures 2.1-2, 2.1-3, and 2.1-4). These wetlands range in size from 0.01 to about 35 acres (see Table 2.1-1), and include slope, depression, and riparian wetlands (Brinson 1993). Palustrine forested, scrub-shrub, emergent, and open-water wetland classes are present within the project area (see Table 2.1-1). A detailed description of all wetlands found within the study area is provided in the *Wetlands Delineation Report* (Parametrix 2000b). Many of the wetlands in the project area are small, degraded by past and ongoing human disturbance, and isolated from other wetlands by areas of unsuitable habitat (e.g., roadways, buildings). Ecological functions of wetlands within the study area are described in the *Wetland Functional Assessment and Impact Analysis Report* (Parametrix 2001b). Mitigation for impacts to the ecological functions that the wetlands provide is described in Section 5 of this document.

## **2.2 STREAMS**

Several stream systems (Walker, Miller, Des Moines, and Gilliam Creeks) occur in the project area. These have been evaluated as part of the environmental review for the Master Plan Update improvements (FAA 1996, 1997a; KCSWM 1987; Hillman et al. 1999; Parametrix 2000c). The following sections describe these stream systems. Additional detailed information on existing ecological conditions in the streams is provided in the *Biological Assessment* (Parametrix 2000c), as well as in the detailed mitigation plan descriptions in Section 5.

### **2.2.1 Miller Creek Basin**

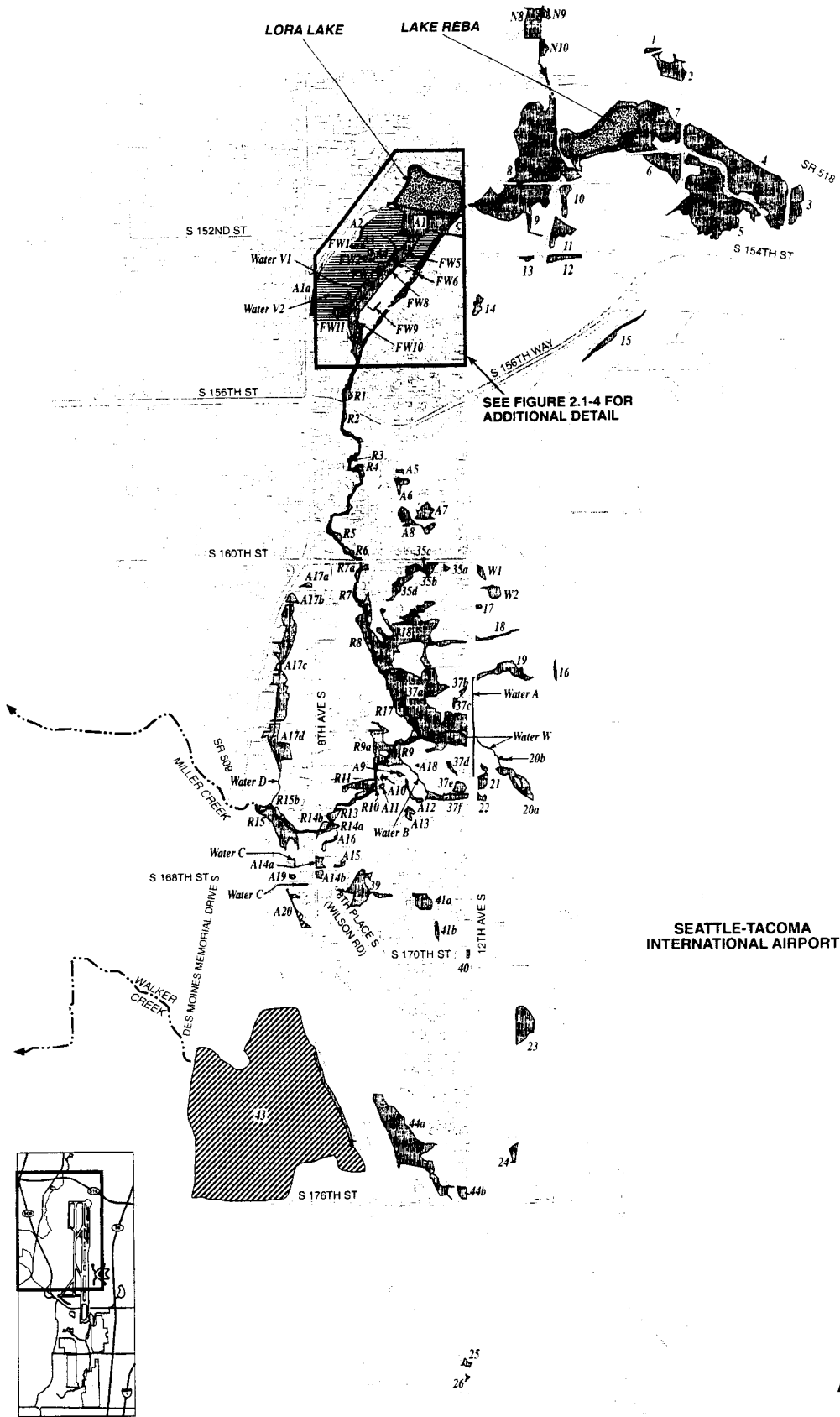
Miller and Walker Creeks, the two streams located in the Miller Creek basin, are near or within the project area. Miller Creek originates at Arbor Lake (near the corner of 5<sup>th</sup> Avenue, south of South 124<sup>th</sup> Street) and flows approximately 5.3 miles to Puget Sound. Walker Creek originates in Wetland 43 west of SR 509 (U.S. Geologic Survey [USGS] Des Moines Quadrangle 1995) and flows into Miller Creek approximately 500 ft upstream of its mouth at Puget Sound (Figure 2.2-1). While a portion of the Walker Creek drainage basin is located within the study area, the stream itself is located approximately 1,000 ft downslope of, and west of, the project area.

#### **2.2.1.1 Miller Creek**

Miller Creek is located in southwest King County and has a basin size of approximately 8 square miles. The Miller Creek basin lies within the Cities of SeaTac and Burien. Flows in Miller Creek originate at three locations: (1) the Arbor, Burien, Tub, and Lora Lakes complex; (2) Lake Reba; and (3) seeps located on the west side of STIA. Miller Creek generally flows south and southwest toward Puget Sound. On the west side of the airport, a number of drainage channels convey water from the plateau and hillslopes to the stream. These channels (King County 1990) have been ditched, and function primarily as surface or groundwater conveyance channels.

---

<sup>5</sup> Other wetlands and aquatic habitats outside the study area are known to occur in the Miller, Walker, and Des Moines Creek basins.



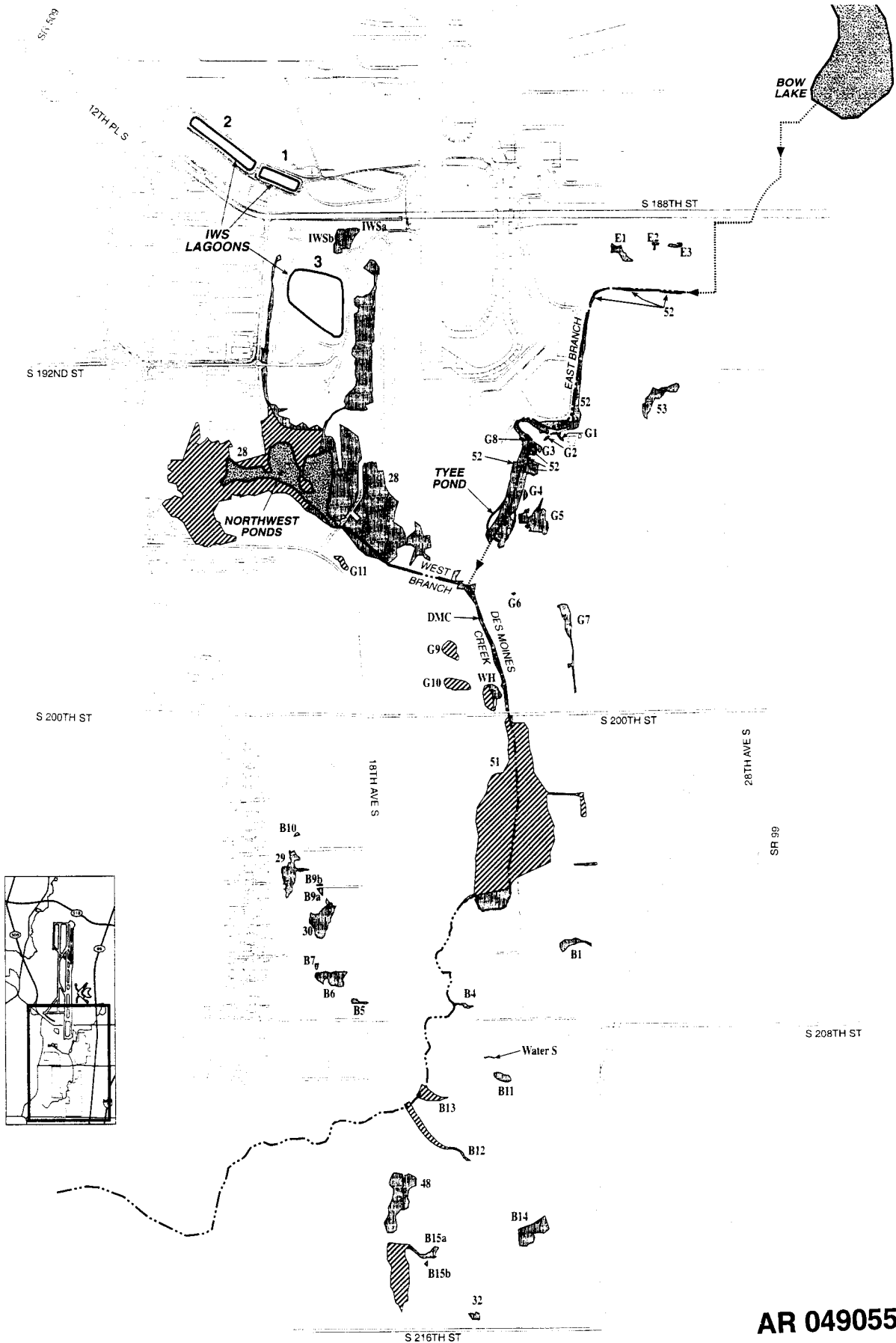
AR 049054

Port of Seattle Natural Resource Mitigation Plan 556-2912-001/01/03: 11/01 (K)



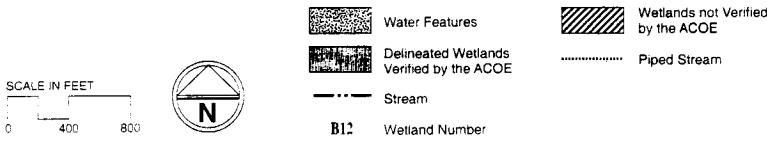
Figure 2.1-2  
Wetlands in the  
Miller Creek Basin  
Near STIA



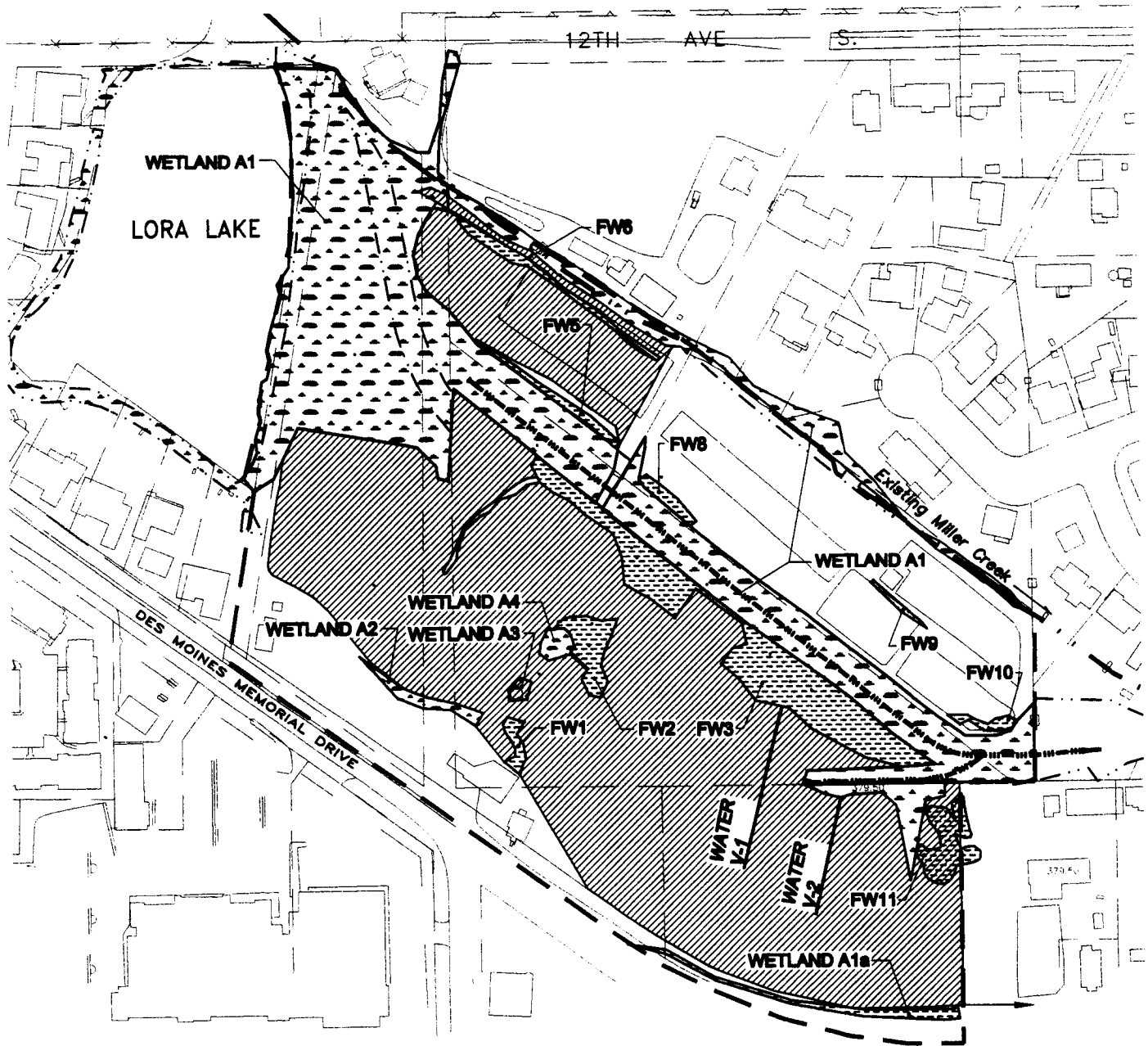


**AR 049055**






Port of Seattle/Natural Resource Mitigation Plan:556-2912-001 011031 1001 (r)



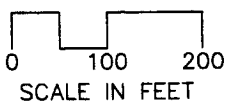
**Figure 2.1-3  
Wetlands in the  
Des Moines Creek Basin  
Near STIA**



**LEGEND:**

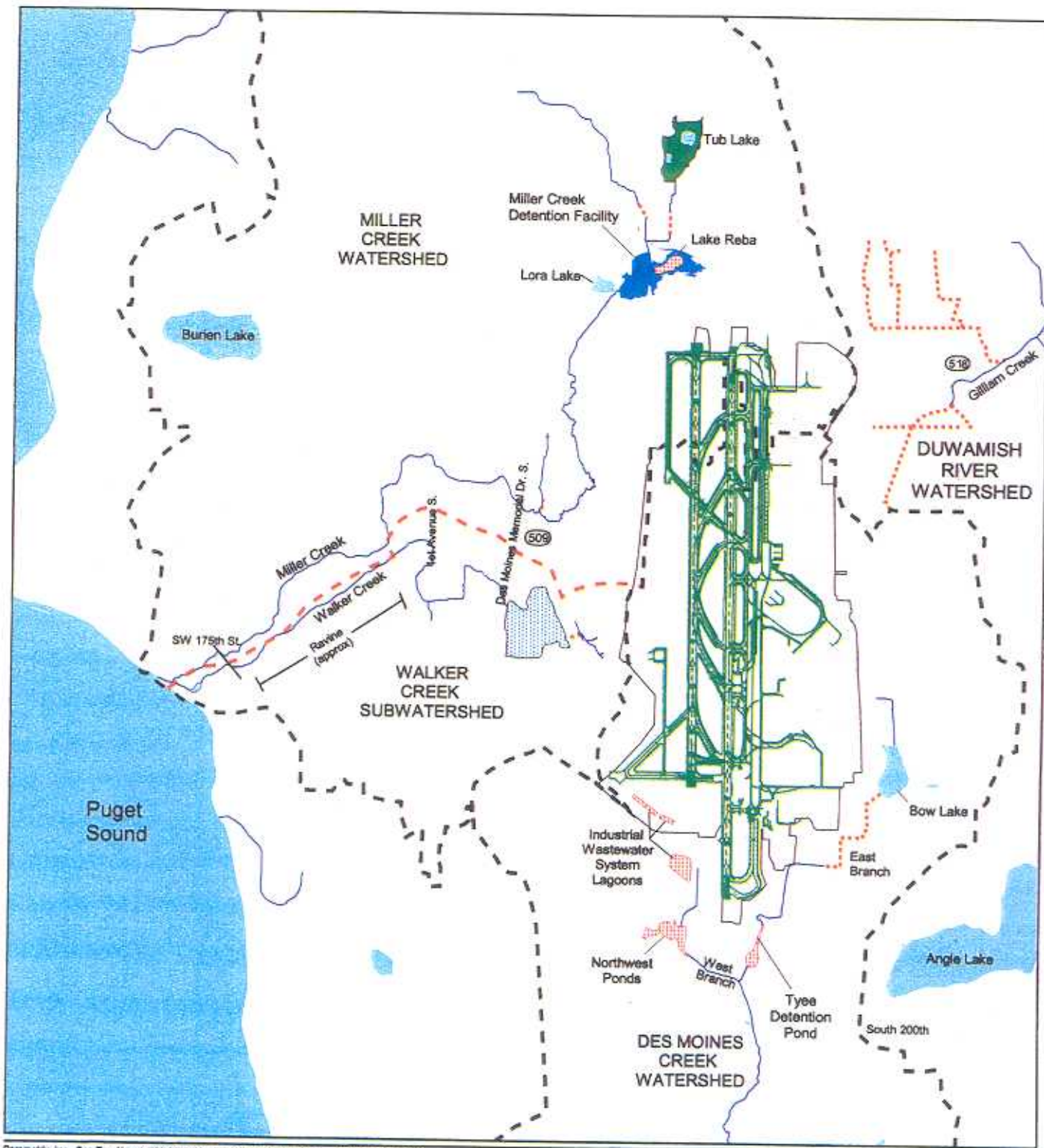
- |                                                                                     |                       |                                                                                     |                                                             |
|-------------------------------------------------------------------------------------|-----------------------|-------------------------------------------------------------------------------------|-------------------------------------------------------------|
|  | Detail Area           |  | Farmed Wetlands (FW),<br>14 Day Inundation (Observed, 3/98) |
|  | Drainage Ditch        |  | Prior Converted<br>Wetlands                                 |
|  | Vegetated<br>Wetlands |                                                                                     |                                                             |

FILE: 291203\_F2  
DATE: 11/15/01

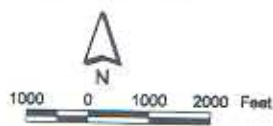


**Figure 2.1-4**  
**Jurisdictional Wetlands**  
**on the Vacca Farm Site**

**AR 049056**



Parametrix, Inc. Sea-Tac Airport /556-2912-001 File: K:\GIS\2912\ArcView\eastac\_4\_jmb\alley.apr  
 Source: Roads based on King County data. Water bodies derived from USGS hypsography data.  
 Detention boundaries are approximate. Estimated wetland boundaries are based on field reconnaissance by Parametrix, Inc.



- Roads
- Streams
- Subwatershed Boundary
- Watershed Boundary
- Piped Stream
- Constructed Water Feature
- Water Bodies
- Detention Facilities (existing)
- Wetland 43
- Sea-Tac Airport
- Wetland N3
- Sea-Tac Airport Runway

**Figure 2.2-1**  
**Location of**  
**Miller Creek,**  
**Walker Creek,**  
**and Des Moines**  
**Creek Near STIA**

Most of the 5,140-acre Miller Creek watershed is developed with residential and commercial properties. Approximately 62 percent of the land use in the basin is residential, 15 percent is commercial, 3 percent is STIA<sup>6</sup> (excluding the IWS drainage area, which treats stormwater runoff prior to being discharged to Puget Sound), and the remaining 20 percent is undeveloped (Montgomery Water Group 1995). Much of the undeveloped land in the watershed is owned by the Port. Commercial land uses are scattered along Des Moines Way, Ambaum Boulevard, and First Avenue South. Some agricultural uses are also found in the upper watershed. Although urbanization throughout the basin has altered the stream and riparian ecosystems, Miller Creek continues to support fish and wildlife species.

### **Stream Classification**

WDFW has classified the lower reaches of Miller Creek as Class II salmon-bearing waters. Miller Creek is designated as an extraordinary (Class AA) quality water body by the Water Quality Standards for Surface Waters of the State of Washington (Washington Administration Code [WAC] 173-201). However, Miller Creek has failed to meet some of the state water quality standards (WQSs) (FAA 1996). Occasional violations of Class AA WQSs for pH, dissolved oxygen, and ammonia have also occurred in the basin (FAA 1996). Runoff from residential, commercial, and agricultural properties has contributed to water quality degradation. Pollutants such as nutrients, organics, metals, fecal coliform bacteria, and suspended solids that are commonly associated with urban runoff have been found in Miller Creek and contribute to occasional violations of state and federal WQSs.

The floodplain in the stream reach between South 156th Way and South 160<sup>th</sup> Street is relatively confined to the channel ravine and is approximately 60 to 100 ft wide. In the stream reach south of South 160<sup>th</sup> Street, the floodplain is approximately 80 to 150 ft wide in the upper reaches. However, farther downstream, it widens to approximately 200 to 250 ft.

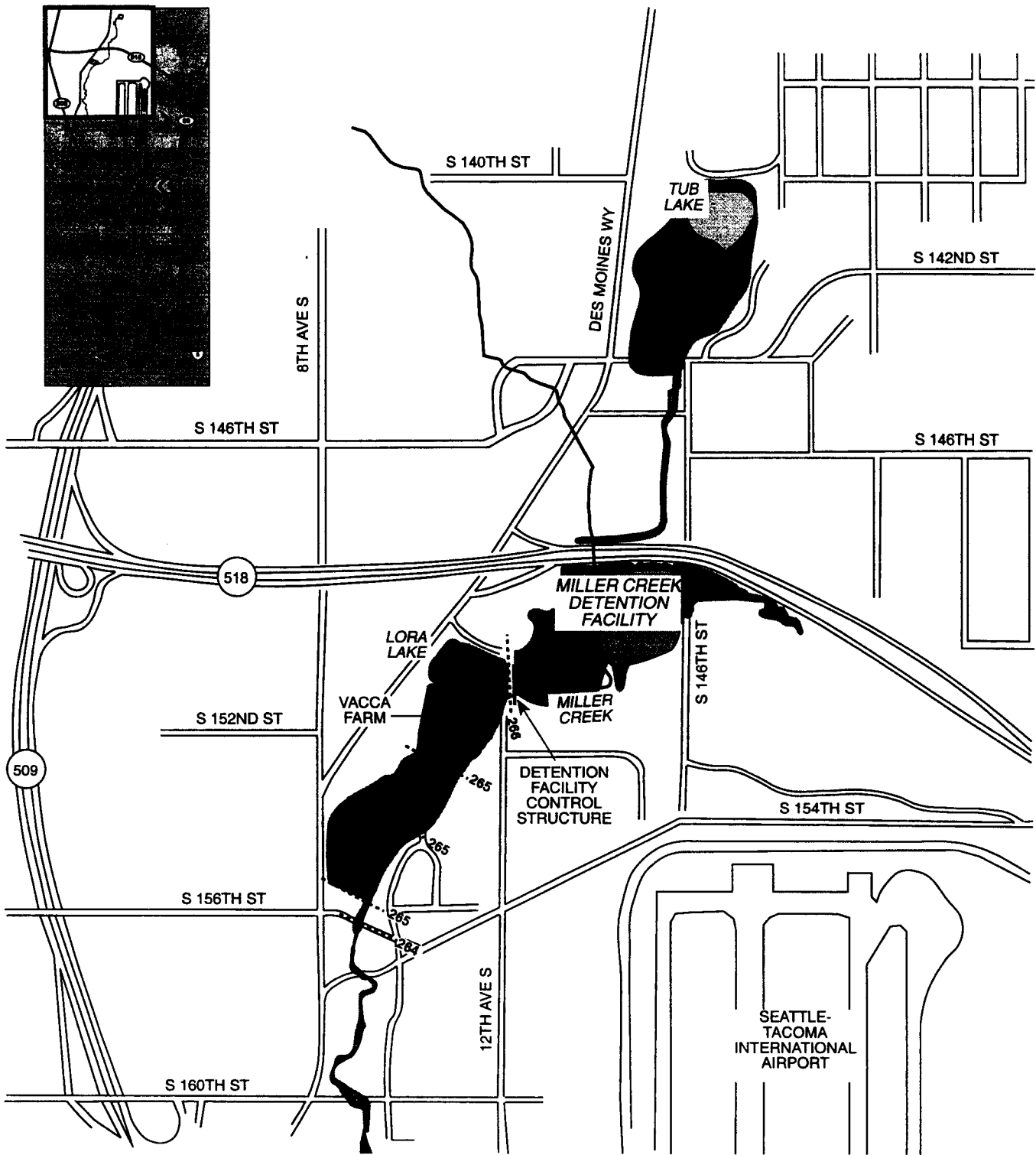
Urbanization and agriculture have significantly altered the floodplains associated with Miller Creek. The wetland filling, riparian vegetation removal, culvert installation, and streambank armoring have reduced stream channel and floodplain capacities. Increased development and impervious surface areas in the basin result in increased stormwater runoff rates and volumes.

The 100-year floodplain in the vicinity of the Vacca Farm site is several acres in size (Figure 2.2-2). The wetland area and poor drainage that existed prior to agricultural drainage activities are evident from the 100-year floodplain estimated by the Federal Emergency Management Agency (FEMA). The approximate 100-year flood elevations, determined by FEMA as part of its study, vary from 266 ft at the Miller Creek detention facility outlet to approximately 265 ft at the downstream end of the Vacca Farm site (see Figure 1.2-2). A floodway has also been delineated and mapped in a portion of the floodplain.

**AR 049058**

---

<sup>6</sup> This area will increase to 9 percent with acquisition of west side property.



Source: FEMA 1995

Port of Seattle/Natural Resource Mitigation Plan/556-2912-001/01(03) 11/01 (K)



NOT TO SCALE

- ..... 100-year Flood Elevation (approximately 265.4 ft)
- ▨ Floodway
- 100-Year Floodplain

**Figure 2.2-2  
Miller Creek  
100-Year Floodplain**

**AR 049059**

### **Miller Creek Tributary Drainage Channels**

Intermittent drainage channels (referred to as Waters A, B, C, D, and W) are located within the Miller Creek basin in the acquisition area and on the west side of the existing runway (see Figure 2.1-2). These channels are regulated as Waters of the U.S. by ACOE, and portions of them are mapped by the *King County Sensitive Areas Portfolio* (King County 1990).<sup>7</sup>

**Water A** is an approximately 814-ft-long by 5-ft-wide (0.09-acre) drainage ditch. This ditch collects surface water runoff from 12<sup>th</sup> Avenue South, the airport security road, and several upslope wetlands (Wetlands 19, 21, and 22). A portion of Water W, which originates in Wetland 20, also drains westward into Water A. These waters drain into Wetland 37 through a culvert under 12<sup>th</sup> Avenue South and convey channelized flow to **Water W** for approximately 494 ft (0.03 acre) to Miller Creek. Water A and portions of Water W are mapped in the King County sensitive area map folio (King County 1990) as an unclassified stream.

**Water B** is an approximately 314-ft-long by 4-ft-wide (0.03-acre) incised channel that conveys water from the west end of Wetland 37f northwest to riparian Wetland R9, which, in turn, drains to Miller Creek.

**Water C** is a discontinuous ditch that flows through culverts or cement-lined channels on Parcel 251. The exposed ditch totals approximately 170 linear ft (0.01 acre) from South 168<sup>th</sup> Street to Miller Creek.

**Water D** is an intermittent stream that begins east of Des Moines Memorial Drive and north of South 160<sup>th</sup> Street. The channel flows approximately 1,830 linear ft (0.16 acre) through several sections of Wetland A17 and enters Miller Creek on Parcel 243, approximately 200 ft upslope of Des Moines Memorial Drive.

#### **2.2.1.2 Walker Creek**

Walker Creek is the major tributary of Miller Creek that drains a 540-acre watershed. The creek originates in Wetland 43 west of SR 509. Several small seep areas located east of SR 509 feed into Wetland 43. Walker Creek flows for approximately 1.3 miles southwest and generally parallel to Miller Creek before joining Miller Creek less than 500 ft upstream of Puget Sound (see Figure 2.2-1). Land use in the Walker Creek basin consists of residential and commercial development in densities similar to those described for Miller Creek. A small portion of Port property drains to Walker Creek. However, no portion of the active runway, airfield, or airport operations area drains to Walker Creek.

The contributing basin to Walker Creek, including Wetland 43, is shown in Figure 2.2-1. Streamflow rates are typically highest between October and April during the wet season and lowest between May and September (FAA 1996). Walker Creek receives stormwater runoff originating from residential and commercial development within the basin, which has likely increased the

---

<sup>7</sup> Other small drainage ditches are present on the Vacca Farm site and connect to Wetland A1. These are described in Parametrix 2000a.

frequency and magnitude of peak flows. Upstream of Southwest 175<sup>th</sup> Street, FEMA classified the floodplain as areas where the 100-year flood depth is less than 1.0 ft, or the drainage area is less than 1 square mile. FEMA also mapped a more extensive (several acres) floodplain from the confluence of Walker and Miller Creeks to Puget Sound.

In the lower gradient upper reaches, Walker Creek flows through confined rockery-hardened banks, several culverts, and along roadside ditches. As the gradient increases, Walker Creek flows through a ravine (downstream of 1<sup>st</sup> Avenue South); however, field evaluations of this area could not be conducted due to limited access to private property. As the gradient decreases below the ravine and above the confluence with Miller Creek, the stream is again confined by urban development, including yards, ditches, and culverts. Walker Creek has riparian cover along most of its length. Trees and shrubs are the dominant vegetation type; however, mowed lawn is also common along the banks (Hillman et al. 1999).

Walker Creek is unclassified by King County; however, it would likely be classified as a Washington Department of Natural Resources (DNR) type 3 stream due to stream size and salmonid use. No studies have measured water quality in Walker Creek; it is likely that the stream has pollutant loads typical of streams in Puget Sound lowland urbanized watersheds, and similar to Miller Creek. Walker Creek supports coho salmon (*Oncorhynchus kisutch*) and chum salmon (*O. keta*) spawning, although a recent survey found that approximately 75 percent of the coho salmon spawning in the stream was from hatcheries (Hillman et al. 1999). The stream has limited LWD, undercut banks, or other types of cover features (Hillman et al. 1999), which in turn limits fish habitat in the stream.

### **2.2.2 Des Moines Creek Basin**

The Des Moines Creek drainage basin consists of about 3,750 acres situated primarily south and southeast of the airport (see Figure 1.2-2). The Des Moines Creek watershed is largely urbanized and includes portions of the Cities of Des Moines, Normandy Park, SeaTac, and Burien. STIA occupies approximately 23 percent of the watershed (excluding other Port properties such as the Tye Valley Golf Course and noise abatement areas). Much of the area directly southeast of the airport was once developed as residential areas, but has been purchased by the Port as part of the Noise Remedy Program. The Tye Valley Golf Course occupies the area immediately south of the airport. The remainder of the watershed is mixed residential, commercial, and industrial uses.

#### **2.2.2.1 Des Moines Creek**

The headwaters of the east branch (considered the mainstem by most locals) originate at Bow Lake, 3.7 river miles (RM) from Puget Sound. The upper half-mile of the east branch, from Bow Lake downstream to about RM 3, is conveyed through underground pipes. The west branch originates from the Northwest Ponds stormwater detention complex located at the western edge of the Tye Valley Golf Course and joins the east branch at approximately RM 2.4. Downstream of South 200<sup>th</sup> Street (RM 2.2), the stream flows through Des Moines Creek Park, a forested riparian wetland. The park includes an incised ravine at about RM 1.8. The ravine is a high-gradient reach in which the stream has cut to hardpan for most of the length providing little quality fish habitat. The stream is paralleled within this ravine by a paved trail and/or service road and sewer line protected in places

by rock bank armoring. The stream drops about 300 ft in elevation from the golf course to a small estuarine mouth at Puget Sound. Two unnamed tributaries enter the stream at about RMs 0.7 and 1.9 (Williams et al. 1975).

Des Moines Creek is designated as an extraordinary (Class AA) quality water body by the Water Quality Standards for Surface Waters of the State of Washington (WAC 173-201). From the west branch downstream of the Northwest Ponds, it is a Class II salmon-bearing stream.

### 2.2.2.2 Drainage Channel

A small drainage channel (**Water S**) is present in Borrow Area 1, south of South 208<sup>th</sup> Street and east of Des Moines Creek (see Figure 2.1-3). Water S, classified as a Water of the U.S., contains intermittent flow, but does not contain wetland soil or vegetation. **Water S** is a 90-ft-long by 3-ft-wide (0.01-acre) channel that conveys water from a small spring into a 4-inch drainage pipe.

### 2.2.3 Gilliam Creek

Gilliam Creek<sup>8</sup> is a small stream that receives runoff from STIA and discharges to the Green/Duwamish River in the vicinity of the City of Tukwila (see Figure 2.2-1). Gilliam Creek, which has been impacted by development, is extensively culverted and receives stormwater runoff that causes high peak flows and low base flows. Fish use of this stream is primarily by resident fish because of the migration barriers that limit anadromous fish passage (Taylor Associates 1996 in City of Tukwila 1997). Fish access between the Green River and Gilliam Creek is restricted by a culvert and flap gate where the stream drains into the Green/Duwamish River. Culverts limit adult salmonid access to much of this tributary, although juvenile chinook and coho salmon have been reported in the stream. The resident fish expected to inhabit this stream and long piped sections include cutthroat trout (*Oncorhynchus clarki clarki*), western brook lamprey (*Lampetra richardsoni*), carp (*Cyprinus* sp.), peamouth (*Mylocheilus caurinus*), largescale sucker (*Catostomus macrocheilus*), threespine stickleback (*Gasterosteus aculeatus*), and sculpin (*Cottus* sp.).

About 50 percent of Gilliam Creek is contained in culverts, and much of the remainder of the stream flows in constructed ditches. Riparian vegetation is lacking along most of the stream corridor or is predominantly herbaceous and provides little shade.

Urban development within the watershed has altered native soils and vegetation, resulting in increased scour and sedimentation in Gilliam Creek. Changes such as stream channelization and the removal of LWD have increased stream degradation and fine sediment input. Scour and erosion characterize the upper reaches of the stream, resulting in downstream sedimentation in the lower reaches. Base flow measurements of water quality indicated that concentrations in Gilliam Creek do not meet Washington State Class A WQSs for pH, dissolved oxygen, dissolved copper, dissolved lead, dissolved zinc, and fecal coliform bacteria (Herrera and RW Beck 2000).

---

<sup>8</sup> Master Plan Update improvements do not add new impervious area, alter wetlands, alter stream channels, or alter stormwater management (including the IWS) in a manner that could impact Gilliam Creek. For these reasons, no natural resource mitigation in this basin is necessary.





### 3. NATURAL RESOURCE IMPACTS SUMMARY

The STIA Master Plan Update improvements will impact wetlands, streams, floodplain, drainage channels, and stormwater in the Miller and Des Moines Creek basins. To construct the projects, fill material will be placed in approximately 980 linear ft of Miller Creek, approximately 5.24 acre-ft of the Miller Creek 100-year floodplain, approximately 18.37 acres of wetland, and about 1,290 linear ft of drainage channel. In addition, new impervious surfaces will impact stormwater runoff and water quality conditions. The impacts of these actions, which are the basis for the mitigation described in Sections 4, 5, and 7 of this report, are described in the FSEIS (FAA 1997a) for the project. Wetland and stream impacts resulting from STIA Master Plan Update improvements are summarized in the discussion that follows. Detailed analyses of these impacts are presented in the following documents:

- *Wetland Functional Assessment and Impact Analysis* (Parametrix 2001b)
- *Comprehensive Stormwater Management Plan for Seattle-Tacoma International Airport Master Plan Improvements* (Parametrix 2000a, 2001a)
- *Final Supplemental Environmental Impact Statement for the Proposed Master Plan Update Development Actions at Seattle-Tacoma International Airport* (FAA 1997a)

#### 3.1 WETLANDS

The FSEIS for the Master Plan Update (FAA 1997a) improvements identified 12.23 acres of wetland that will be directly impacted by Master Plan Update improvements (FAA 1997a; Parametrix 1996a). These determinations represented the best available information at the time of publication. Information supporting these determinations was obtained through field delineations and aerial photographic interpretation. Aerial photographic interpretation was used in the west side acquisition area where the Port lacked access to private properties necessary to conduct wetland delineations and subsequent agency review.

Since the publication of the FSEIS, the Port has purchased property and delineated wetlands that are subject to temporary or permanent impacts from the runway embankment, construction activities, and stormwater management (see *Wetland Delineation Report*, Parametrix 2000b). All wetlands within the acquisition area have been delineated.

##### 3.1.1 Permanent Impacts

Permanent wetland impacts from Master Plan Update improvements will affect about 18.37 acres (Table 3.1-1, Figures 3.1-1 and 3.1-2, and the *Wetland Functional Assessment and Impact Analysis* [Parametrix 2001b]). Mitigation for these impacts is described in Sections 4 (overview), 5 (on-site), and 7 (off-site).

Permanent wetland impacts (fill and potential indirect) include approximately 8.17 acres of forest, 2.98 acres of shrub, and 7.22 acres of emergent habitat. Lower quality wetlands (Category III and Category IV) account for about 50 percent of the wetlands impacted by fill (Table 3.1-2). The remaining wetland impact areas affect higher quality Category II wetlands. All impacted wetlands

have been subjected to significant historic or ongoing disturbances that have reduced their ecological value and ecosystem function (Parametrix 2001b) below what would be expected for undisturbed wetlands occurring in undeveloped areas. Regardless of wetland rating or evidence of human degradation, the functions of each wetland have been analyzed and mitigated.

**Table 3.1-1. Summary of wetland impacts for Seattle-Tacoma International Airport Master Plan Update improvements by construction project.**

| Wetland Number                      | Vegetation Type <sup>a</sup> | Indirect Impact (acres) | Direct Impact (acres) | Total Impact (acres) <sup>b</sup> | Vegetation Types Impacted (acres) |             |             |
|-------------------------------------|------------------------------|-------------------------|-----------------------|-----------------------------------|-----------------------------------|-------------|-------------|
|                                     |                              |                         |                       |                                   | Forest                            | Shrub       | Emergent    |
| <b>Runway Safety Area Extension</b> |                              |                         |                       |                                   |                                   |             |             |
| 5                                   | Shrub                        | 0.00                    | 0.14                  | 0.14                              | 0.07                              | 0.07        | 0.00        |
|                                     | <b>Subtotal</b>              | <b>0.00</b>             | <b>0.14</b>           | <b>0.14</b>                       | <b>0.07</b>                       | <b>0.07</b> | <b>0.00</b> |
| <b>Third Runway Project Area</b>    |                              |                         |                       |                                   |                                   |             |             |
| <u>North Airfield</u>               |                              |                         |                       |                                   |                                   |             |             |
| 9                                   | Forest/Emergent              | 0.00                    | 0.03                  | 0.03                              | 0.01                              | 0.00        | 0.02        |
| 11                                  | Forest/Emergent              | 0.16                    | 0.34                  | 0.50                              | 0.40                              | 0.00        | 0.10        |
| 12                                  | Forest/Emergent              | 0.00                    | 0.21                  | 0.21                              | 0.04                              | 0.00        | 0.17        |
| 13                                  | Emergent                     | 0.00                    | 0.05                  | 0.05                              | 0.00                              | 0.00        | 0.05        |
| 14                                  | Forest                       | 0.00                    | 0.19                  | 0.19                              | 0.19                              | 0.00        | 0.00        |
| <u>West Airfield</u>                |                              |                         |                       |                                   |                                   |             |             |
| 15                                  | Emergent                     | 0.00                    | 0.28                  | 0.28                              | 0.00                              | 0.00        | 0.28        |
| 16                                  | Emergent                     | 0.00                    | 0.05                  | 0.05                              | 0.00                              | 0.00        | 0.05        |
| 17                                  | Emergent                     | 0.00                    | 0.02                  | 0.02                              | 0.00                              | 0.00        | 0.02        |
| 18                                  | Forest/Shrub/<br>Emergent    | 0.55                    | 2.29                  | 2.84                              | 1.28                              | 0.75        | 0.81        |
| 19                                  | Forest                       | 0.00                    | 0.56                  | 0.56                              | 0.56                              | 0.00        | 0.00        |
| 20                                  | Shrub/Emergent               | 0.00                    | 0.57                  | 0.57                              | 0.00                              | 0.51        | 0.06        |
| 21                                  | Forest                       | 0.00                    | 0.22                  | 0.22                              | 0.22                              | 0.00        | 0.00        |
| 22                                  | Shrub/Emergent               | 0.00                    | 0.06                  | 0.06                              | 0.00                              | 0.01        | 0.05        |
| 23                                  | Emergent                     | 0.00                    | 0.77                  | 0.77                              | 0.00                              | 0.00        | 0.77        |
| 24                                  | Emergent                     | 0.00                    | 0.14                  | 0.14                              | 0.00                              | 0.00        | 0.14        |
| 25                                  | Forest                       | 0.00                    | 0.06                  | 0.06                              | 0.06                              | 0.00        | 0.00        |
| 26                                  | Emergent                     | 0.00                    | 0.02                  | 0.02                              | 0.00                              | 0.00        | 0.02        |
| W1                                  | Forest/Emergent              | 0.00                    | 0.10                  | 0.10                              | 0.00                              | 0.00        | 0.10        |
| W2                                  | Forest/Emergent              | 0.00                    | 0.22                  | 0.22                              | 0.04                              | 0.00        | 0.18        |
| <u>West Acquisition Area</u>        |                              |                         |                       |                                   |                                   |             |             |
| 35a-d                               | Forest/Emergent              | 0.04                    | 0.63                  | 0.67                              | 0.27                              | 0.00        | 0.40        |
| 37a-f                               | Forest/Emergent              | 0.36                    | 3.75                  | 4.11                              | 2.86                              | 0.00        | 1.25        |
| 40                                  | Forest                       | 0.00                    | 0.03                  | 0.03                              | 0.00                              | 0.03        | 0.00        |
| 41a and b <sup>c</sup>              | Emergent                     | 0.00                    | 0.44                  | 0.44                              | 0.00                              | 0.00        | 0.44        |
| 44a and b                           | Forest                       | 0.00                    | 0.26                  | 0.26                              | 0.18                              | 0.08        | 0.00        |
| A5                                  | Emergent                     | 0.02                    | 0.01                  | 0.03                              | 0.00                              | 0.00        | 0.03        |
| A6                                  | Forest                       | 0.09                    | 0.07                  | 0.16                              | 0.16                              | 0.00        | 0.00        |
| A7                                  | Forest                       | 0.00                    | 0.30                  | 0.30                              | 0.30                              | 0.00        | 0.00        |

**Table 3.1-1. Summary of wetland impacts for Seattle-Tacoma International Airport Master Plan Update improvements by construction project (all values are in acres) (continued).**

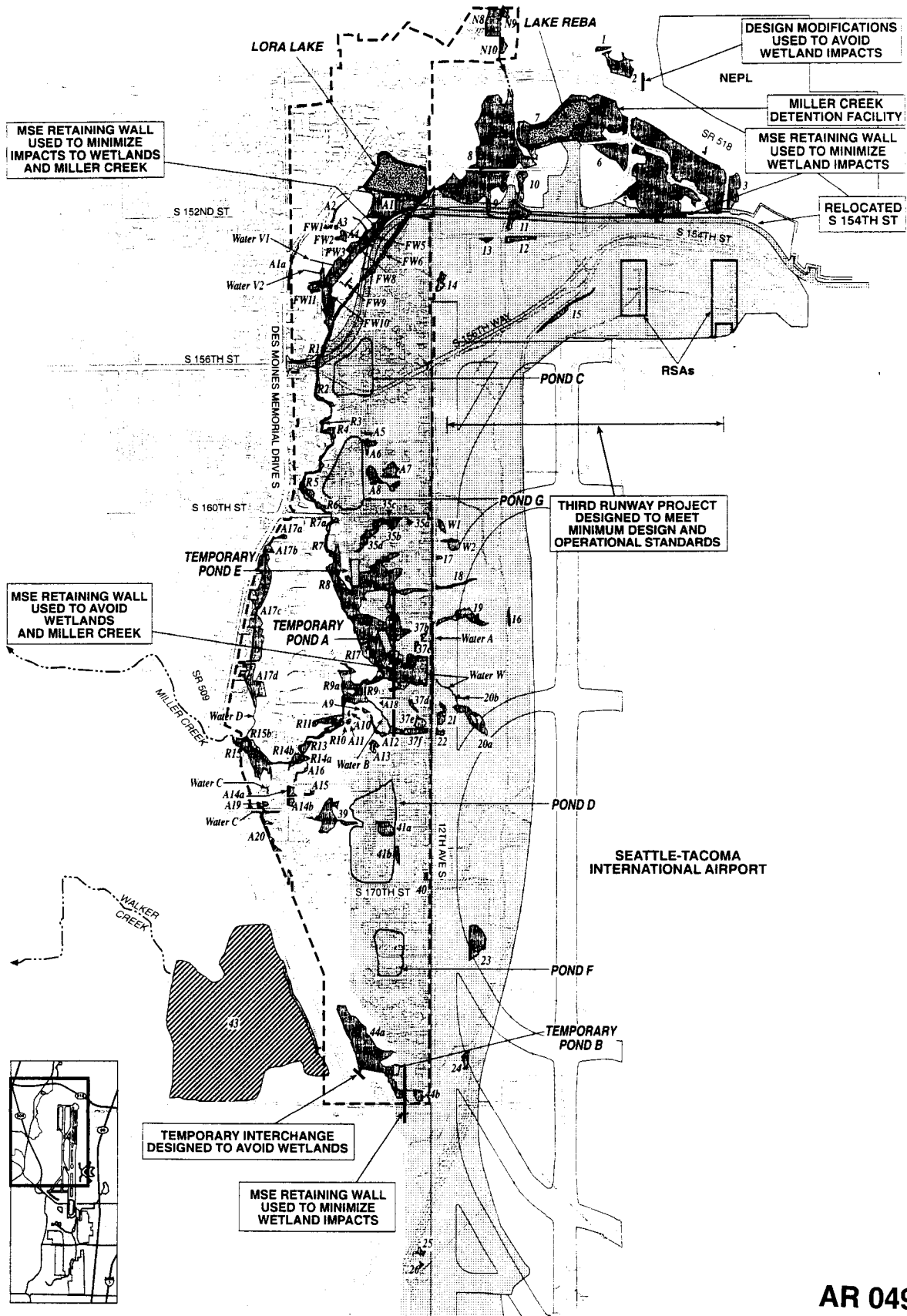
| Wetland Number                                             | Vegetation Type <sup>a</sup> | Indirect Impact (acres) | Direct Impact (acres) | Total Impact (acres) <sup>b</sup> | Vegetation Types Impacted (acres) |             |             |
|------------------------------------------------------------|------------------------------|-------------------------|-----------------------|-----------------------------------|-----------------------------------|-------------|-------------|
|                                                            |                              |                         |                       |                                   | Forest                            | Shrub       | Emergent    |
| A8                                                         | Forest/Shrub                 | 0.00                    | 0.38                  | 0.38                              | 0.07                              | 0.31        | 0.00        |
| A12                                                        | Shrub                        | 0.06                    | 0.02                  | 0.08                              | 0.00                              | 0.08        | 0.00        |
| A 18                                                       | Shrub                        | 0.01                    | 0.00                  | 0.01                              | 0.00                              | 0.01        | 0.00        |
| <b>Vacca Farm Site</b>                                     |                              |                         |                       |                                   |                                   |             |             |
| A1                                                         | Forest/Shrub/<br>Emergent    | 0.00                    | 0.59                  | 0.59                              | 0.09                              | 0.09        | 0.41        |
| FW 5                                                       | Farmed Wetland               | 0.00                    | 0.08                  | 0.08                              | 0.00                              | 0.00        | 0.08        |
| FW 6                                                       | Farmed Wetland               | 0.00                    | 0.07                  | 0.07                              | 0.00                              | 0.00        | 0.07        |
| <b>Riparian Wetland</b>                                    |                              |                         |                       |                                   |                                   |             |             |
| R1                                                         | Emergent                     | 0.00                    | 0.13                  | 0.13                              | 0.00                              | 0.00        | 0.13        |
|                                                            | <b>Subtotal</b>              | <b>1.29</b>             | <b>12.94</b>          | <b>14.23</b>                      | <b>6.73</b>                       | <b>1.87</b> | <b>5.63</b> |
| <b>South Aviation Support Area/Tyee Valley Golf Course</b> |                              |                         |                       |                                   |                                   |             |             |
| 52                                                         | Forest/Shrub/<br>Emergent    | 0.54                    | 0.00                  | 0.54                              | 0.54                              | 0.00        | 0.00        |
| 53                                                         | Forest                       | 0.00                    | 0.60                  | 0.60                              | 0.60                              | 0.00        | 0.00        |
| E2                                                         | Forest                       | 0.00                    | 0.04                  | 0.04                              | 0.04                              | 0.00        | 0.00        |
| E3                                                         | Forest                       | 0.00                    | 0.06                  | 0.06                              | 0.06                              | 0.00        | 0.00        |
| G1                                                         | Shrub (Slope)                | 0.00                    | 0.05                  | 0.05                              | 0.00                              | 0.05        | 0.00        |
| G2                                                         | Emergent                     | 0.00                    | 0.02                  | 0.02                              | 0.00                              | 0.00        | 0.02        |
| G3                                                         | Emergent                     | 0.02                    | 0.04                  | 0.06                              | 0.00                              | 0.00        | 0.06        |
| G4                                                         | Emergent                     | 0.04                    | 0.00                  | 0.04                              | 0.00                              | 0.00        | 0.04        |
| G5                                                         | Emergent                     | 0.47                    | 0.40                  | 0.87                              | 0.00                              | 0.00        | 0.87        |
| G7                                                         | Forest/Shrub                 | 0.00                    | 0.50                  | 0.50                              | 0.13                              | 0.37        | 0.00        |
|                                                            | <b>Subtotal</b>              | <b>1.07</b>             | <b>1.71</b>           | <b>2.78</b>                       | <b>1.37</b>                       | <b>0.42</b> | <b>0.99</b> |
| <b>Borrow Area and Haul Road</b>                           |                              |                         |                       |                                   |                                   |             |             |
| 28                                                         | Emergent                     | 0.00                    | 0.07                  | 0.07                              | 0.00                              | 0.00        | 0.07        |
| B11                                                        | Emergent                     | 0.00                    | 0.18                  | 0.18                              | 0.00                              | 0.00        | 0.18        |
| B12                                                        | Forest                       | 0.04                    | 0.03                  | 0.07                              | 0.00                              | 0.07        | 0.00        |
| B14                                                        | Shrub                        | 0.00                    | 0.78                  | 0.78                              | 0.00                              | 0.55        | 0.23        |
|                                                            | <b>Subtotal</b>              | <b>0.04</b>             | <b>1.06</b>           | <b>1.10</b>                       | <b>0.00</b>                       | <b>0.62</b> | <b>0.48</b> |
| <b>Mitigation<sup>d</sup></b>                              |                              |                         |                       |                                   |                                   |             |             |
| Auburn area 7                                              | Emergent                     | 0.00                    | 0.02                  | 0.02                              | 0.00                              | 0.00        | 0.02        |
| Auburn area 9                                              | Emergent                     | 0.00                    | 0.03                  | 0.03                              | 0.00                              | 0.00        | 0.03        |
| Auburn area 10                                             | Emergent                     | 0.00                    | 0.07                  | 0.07                              | 0.00                              | 0.00        | 0.07        |
|                                                            | <b>Subtotal</b>              | <b>0.00</b>             | <b>0.12</b>           | <b>0.12</b>                       | <b>0.00</b>                       | <b>0.00</b> | <b>0.12</b> |
| <b>TOTAL</b>                                               |                              | <b>2.40</b>             | <b>15.97</b>          | <b>18.37</b>                      | <b>8.17</b>                       | <b>2.98</b> | <b>7.22</b> |

<sup>a</sup> All wetlands are palustrine, based on USFWS wetland classification system (Cowardin et al. 1979).

<sup>b</sup> Values are rounded to two significant figures. Wetland impact may be subject to minor changes.

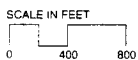
<sup>c</sup> This area includes 0.18 acre of open water habitat.

<sup>d</sup> Impacts in this area result from access road construction.



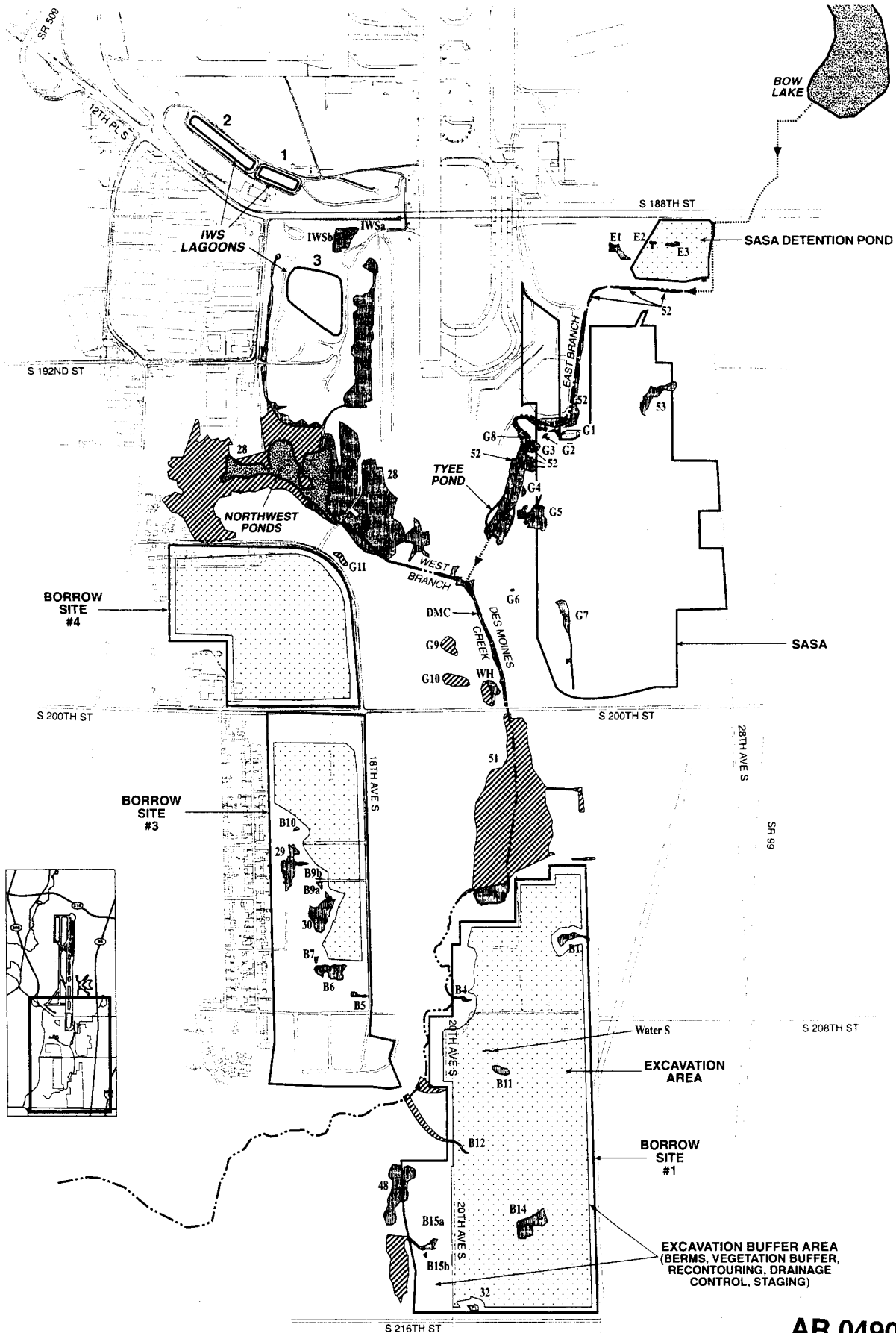
AR 049067

Port of Seattle/Natural Resource Mitigation Plan  
556-2912-001/0 (03) 11/01 (K)



- Wetlands not Verified by ACOE
- Delineated Wetlands Verified by ACOE
- Stream
- Acquisition Area Boundary
- Water Features
- Construction Area (Fill and Grading for Third Runway, Runway Safety Areas, and S 154th Street Relocation)
- Wetland Number

Figure 3.1-1  
Wetland Impacts in the  
Miller Creek Basin  
Near STIA



AR 049068

Port of Seattle/Natural Resource Mitigation Plan/556-2912-001/01(03) 10/01 (K)

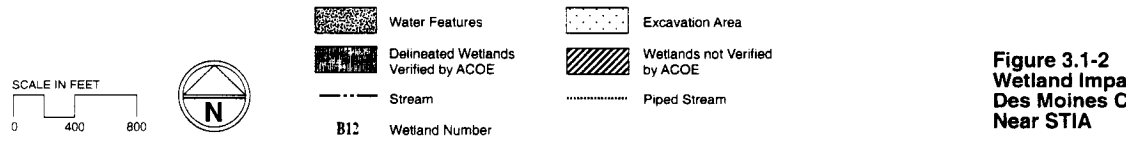


Figure 3.1-2  
Wetland Impacts in the  
Des Moines Creek Basin  
Near STIA

**Table 3.1-2. Summary of permanent wetland impacts by project and wetland category<sup>a</sup> (in acres).**

| <b>Project</b>                   | <b>Category II</b> | <b>Category III</b> | <b>Category IV</b> | <b>Total</b> |
|----------------------------------|--------------------|---------------------|--------------------|--------------|
| RSA                              | 0.00               | 0.14                | 0.00               | <b>0.14</b>  |
| Third Runway                     | 8.37               | 4.89                | 0.97               | <b>14.23</b> |
| Borrow Area 1 and Haul Rd        | 0.14               | 0.96                | 0.00               | <b>1.10</b>  |
| SASA                             | 0.54               | 1.20                | 1.04               | <b>2.78</b>  |
| Off-site Mitigation <sup>b</sup> | 0.00               | 0.12                | 0.00               | <b>0.12</b>  |
| <b>TOTAL</b>                     | <b>9.05</b>        | <b>7.31</b>         | <b>2.01</b>        | <b>18.37</b> |

<sup>a</sup> Wetlands are categorized according to Ecology (1993).

<sup>b</sup> Impacts result from a permanent access road in an emergent wetland at the Auburn mitigation project.

### **3.1.2 Temporary Construction Impacts**

During Master Plan Update improvement project construction, a maximum of 2.05 acres of wetland could temporarily be disturbed by construction activities, stormwater management, and temporary erosion and sediment control (TESC) facilities (Table 3.1-3 and Figure 3.1-3) (Parametrix 2001b). Upon completion of construction, temporarily impacted areas will be restored. Restoration activities will include removing invasive plant species, planting native species, and regrading temporarily impacted emergent wetlands to create higher quality forest, shrub, and open water wetlands.<sup>9</sup> The category rating of these wetlands will not change as a result of the temporary impacts or the mitigation.

Approximately 43.34 acres of wetland will be disturbed during mitigation activities (Table 3.1-4) (Parametrix 2001b). These impacts include temporary and permanent access road construction in wetlands and use of wetlands for temporary construction staging. Areas subject to temporary construction impacts will be regraded and replanted following construction. At the mitigation site in Auburn, construction impacts to emergent wetlands dominated by pasture grasses may exceed 36 months, but could be substantially less if construction windows (daily and annual) are extended.

### **3.1.3 Fragmentation and Indirect Impacts**

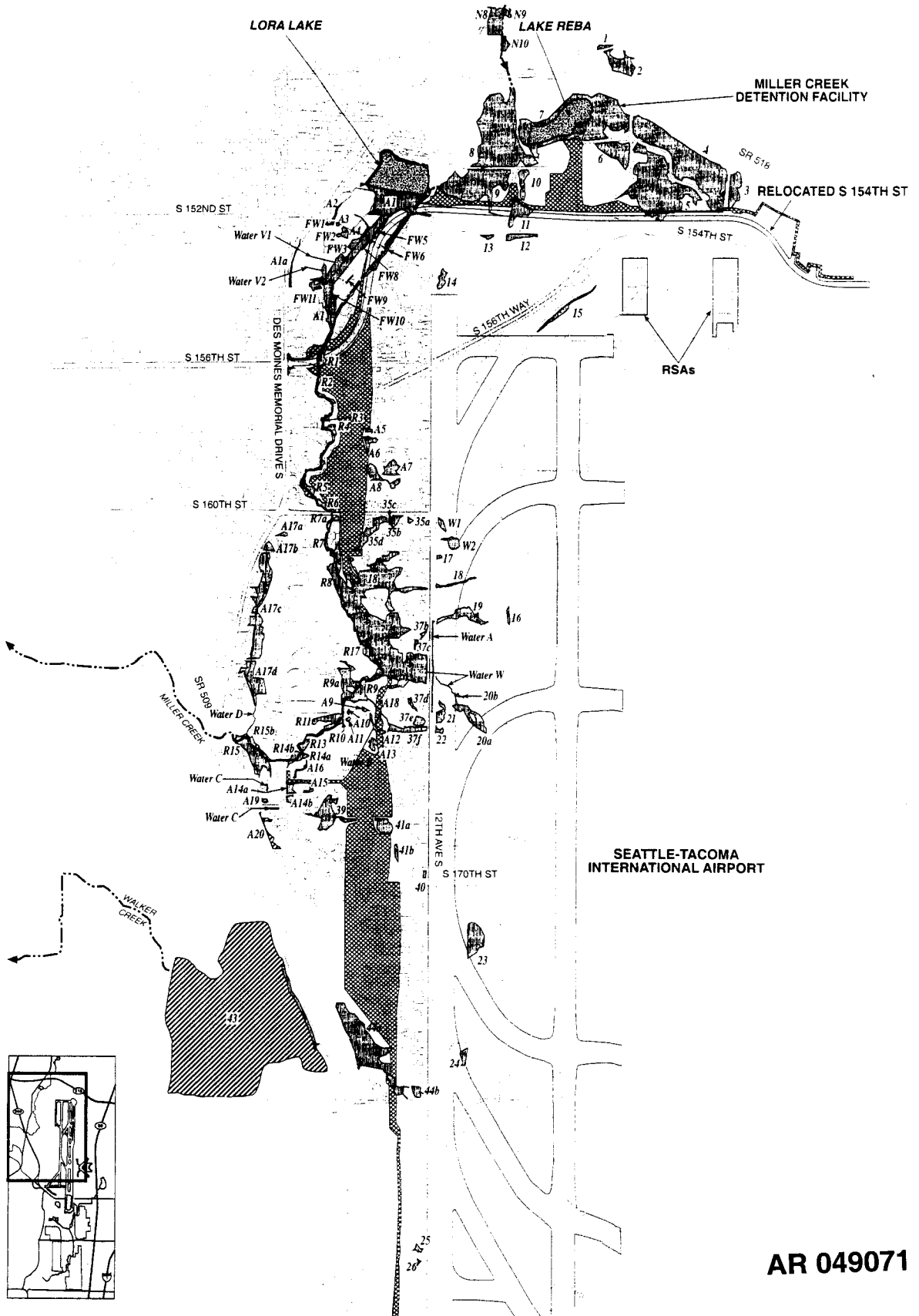
Where fill impacts to wetlands result in small fragments of remaining wetlands, the remaining wetland area has been considered permanently impacted, and tabulated in Table 3.1-1. For example, the small areas of Wetland A6 and A8 located between the runway embankment and proposed stormwater detention facilities may not persist as functioning wetland following completion of the project. *Fragmentation impacts* were evaluated by considering if, given the remaining fragment of wetland and the future project condition, the wetland would be capable of providing the suite of functions it currently does. Where the remaining wetland was, as a result of mitigation, incorporated into enhanced and protected buffers, it typically would remain functional. If, however, a wetland fragment were to remain isolated from other more significant habitat, its functions would be impaired and the indirect impact was considered significant. In these cases, the area of the wetland fragment was added to the amount of direct impacts.

<sup>9</sup> Methods for assessing temporary impacts are described in Section 2.1 of the *Wetland Functional Assessment and Impact Analysis* (Parametrix 2001b). To supplement restoration and reduce temporal impacts, additional mitigation for temporary impacts is included in this plan.

Table 3.1-3. Summary of direct temporary construction impacts to wetlands in the proposed Master Plan Update improvement area.

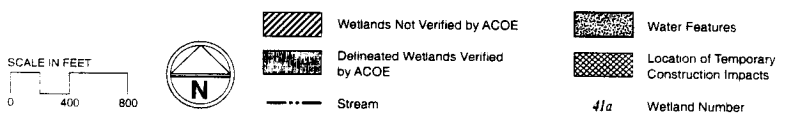
| Wetland                             | Duration  | Area (acres) | Vegetation Types (acres) |             |             | Impacts                                                                                                                                                                                                                                                                                                                                                                                                                                                                               |             |
|-------------------------------------|-----------|--------------|--------------------------|-------------|-------------|---------------------------------------------------------------------------------------------------------------------------------------------------------------------------------------------------------------------------------------------------------------------------------------------------------------------------------------------------------------------------------------------------------------------------------------------------------------------------------------|-------------|
|                                     |           |              | Forest                   | Shrub       | Emergent    |                                                                                                                                                                                                                                                                                                                                                                                                                                                                                       |             |
| <b>Runway Safety Area Extension</b> |           |              |                          |             |             |                                                                                                                                                                                                                                                                                                                                                                                                                                                                                       |             |
| 4                                   | 1 year    | 0.20         | 0.20                     | 0.00        | 0.00        | Temporary construction disturbance could occur in the portion of the wetlands that borders the construction area. These impacts could include minor soil disturbance or siltation caused by installation and removal of erosion control fences. Small amounts of shrub or herbaceous vegetation could be trimmed during installation or maintenance of the fences.                                                                                                                    |             |
| 5                                   | 1 year    | 0.20         | 0.10                     | 0.10        | 0.00        |                                                                                                                                                                                                                                                                                                                                                                                                                                                                                       |             |
| <b>Third Runway</b>                 |           |              |                          |             |             |                                                                                                                                                                                                                                                                                                                                                                                                                                                                                       |             |
| 9                                   | 1 year    | 0.16         | 0.11                     | 0.00        | 0.05        | Construction activity and noise could disturb wildlife during portions of the construction period.                                                                                                                                                                                                                                                                                                                                                                                    |             |
| A1                                  | 1.5 years | 0.05         | 0.01                     | 0.01        | 0.03        |                                                                                                                                                                                                                                                                                                                                                                                                                                                                                       |             |
| 18                                  | 3 years   | 0.22         | 0.04                     | 0.07        | 0.11        | The temporary erosion and sediment control (TESC) collection swales and a collection pond in Wetland 37 would eliminate water quality and habitat functions during the construction period.                                                                                                                                                                                                                                                                                           |             |
| 37                                  | 2 years   | 0.71         | 0.14                     | 0.18        | 0.39        | (Note: Permanent stormwater management facilities will be located outside of wetland areas. Impacts of temporary Pond E have been considered permanent.)                                                                                                                                                                                                                                                                                                                              |             |
| A12                                 | 3 years   | 0.03         | 0.00                     | 0.03        | 0.00        |                                                                                                                                                                                                                                                                                                                                                                                                                                                                                       |             |
| A13                                 | 3 years   | 0.01         | 0.01                     | 0.00        | 0.00        | A narrow band of temporary disturbance could result from installation of erosion control fences adjacent to the fill footprint and the security road. This disturbance will be within 30 ft of Miller Creek for about 100 linear ft. These impacts could include minor soil disturbance or siltation caused by installation and removal of erosion control fences. Small amounts of shrub or herbaceous vegetation could be trimmed during installation or maintenance of the fences. |             |
| 44a                                 | 0.5 year  | 0.00         |                          |             |             | Construction activity and noise could cause disturbance to wildlife.<br><b>SR 509</b> - Temporary Interchange - Construction activity and noise could disturb wildlife during portions of the construction period.                                                                                                                                                                                                                                                                    |             |
|                                     | 3 years   | 0.28         | 0.18                     | 0.10        | 0.00        | <b>Embankment TESC</b> - The TESC pond would eliminate habitat and water quality functions during the construction period.                                                                                                                                                                                                                                                                                                                                                            |             |
| <b>South Aviation Support Area</b>  |           |              |                          |             |             |                                                                                                                                                                                                                                                                                                                                                                                                                                                                                       |             |
| 52                                  | 2 years   | 0.17         | 0.00                     | 0.05        | 0.12        | Construction activity and noise could disturb wildlife during portions of the construction period.<br>Temporary construction disturbance could occur in the portion of the wetlands that borders the bridge construction area. These impacts could include minor soil disturbance or siltation caused by installation and removal of erosion control fences. Small amounts of shrub or herbaceous vegetation could be trimmed during installation or maintenance of the fences.       |             |
|                                     |           | <b>TOTAL</b> |                          | <b>2.05</b> | <b>0.79</b> | <b>0.54</b>                                                                                                                                                                                                                                                                                                                                                                                                                                                                           | <b>0.72</b> |





AR 049071

Port of Seattle Natural Resource Mitigation Plan: S56-2912-001/011031 11/01 (K)



**Figure 3.1-3**  
Location of Temporary Wetland  
Impacts in the Miller Creek  
Basin Near STIA

Table 3.1-4. Summary of wetlands disturbed during mitigation activities.

| Wetland                                                                                                                                  | Vegetation Types      | Total Area<br>(acres) | Vegetation Type Disturbed (acres) |             |              |
|------------------------------------------------------------------------------------------------------------------------------------------|-----------------------|-----------------------|-----------------------------------|-------------|--------------|
|                                                                                                                                          |                       |                       | Forest                            | Shrub       | Emergent     |
| <b>Temporary impacts to wetlands associated with implementing mitigation that includes excavation or installation of temporary roads</b> |                       |                       |                                   |             |              |
| FW 1, 2, 3, 8, 9,<br>10, and FW 11 <sup>a</sup>                                                                                          | Farmed Wetlands       | 0.88                  | 0.00                              | 0.00        | 0.88         |
| A1 <sup>a</sup>                                                                                                                          | Forest/Shrub/Emergent | 3.74                  | 0.56                              | 0.56        | 2.62         |
| A2 <sup>a</sup>                                                                                                                          | Shrub                 | 0.05                  | 0.00                              | 0.05        | 0.00         |
| A3 <sup>a</sup>                                                                                                                          | Shrub                 | 0.01                  | 0.00                              | 0.01        | 0.00         |
| A4 <sup>a</sup>                                                                                                                          | Shrub                 | 0.03                  | 0.00                              | 0.03        | 0.00         |
| Auburn Area 1 <sup>b</sup>                                                                                                               | Emergent              | 1.55                  | 0.00                              | 0.00        | 1.55         |
| Auburn Area 2 <sup>c</sup>                                                                                                               | Emergent              | 0.06                  | 0.00                              | 0.00        | 0.06         |
| Auburn Area 3 <sup>c</sup>                                                                                                               | Emergent              | 5.11                  | 0.00                              | 0.00        | 5.11         |
| Auburn Area 4 <sup>c</sup>                                                                                                               | Emergent              | 0.99                  | 0.00                              | 0.00        | 0.99         |
| Auburn Area 5 <sup>c</sup>                                                                                                               | Emergent              | 3.27                  | 0.00                              | 0.00        | 3.27         |
| Auburn Area 6 <sup>c</sup>                                                                                                               | Emergent              | 0.35                  | 0.00                              | 0.00        | 0.35         |
| Auburn Area 8 <sup>c</sup>                                                                                                               | Emergent              | 0.60                  | 0.00                              | 0.00        | 0.60         |
| Auburn Area 11 <sup>c</sup>                                                                                                              | Emergent              | 0.01                  | 0.00                              | 0.00        | 0.01         |
| Auburn <sup>d</sup>                                                                                                                      | Emergent              | 2.20                  | 0.00                              | 0.00        | 2.20         |
|                                                                                                                                          | <b>Subtotal</b>       | <b>18.85</b>          | <b>0.56</b>                       | <b>0.65</b> | <b>17.64</b> |
| <b>Temporary impacts in wetlands associated with enhancement planting</b>                                                                |                       |                       |                                   |             |              |
| 18 <sup>e</sup>                                                                                                                          | Forest/Shrub/Emergent | 1.27                  | 1.27                              | 0.00        | 0.00         |
| 28 <sup>f</sup>                                                                                                                          | Forest/Shrub/Emergent | 4.50                  | 0.00                              | 0.00        | 4.50         |
| 37a <sup>e,i</sup>                                                                                                                       | Forest/Emergent       | 1.96                  | 1.50                              | 0.00        | 0.46         |
| A1 <sup>e,i</sup>                                                                                                                        | Forest/Shrub/Emergent | 0.34                  | 0.34                              | 0.00        | 0.00         |
| A9 <sup>e,i</sup>                                                                                                                        | Shrub                 | 0.04                  | 0.00                              | 0.04        | 0.00         |
| A10 <sup>e,i</sup>                                                                                                                       | Shrub                 | 0.01                  | 0.00                              | 0.01        | 0.00         |
| A11 <sup>e,i</sup>                                                                                                                       | Shrub                 | 0.02                  | 0.00                              | 0.02        | 0.00         |
| A13 <sup>e,i</sup>                                                                                                                       | Forest                | 0.12                  | 0.12                              | 0.00        | 0.00         |
| A16 <sup>e,i</sup>                                                                                                                       | Shrub/Emergent        | 0.05                  | 0.00                              | 0.00        | 0.05         |
| A17 <sup>e,i</sup> , Water D                                                                                                             | Forest/Shrub/Emergent | 2.85                  | 0.27                              | 0.53        | 2.05         |
| N8, N9, N10 <sup>e</sup>                                                                                                                 | Emergent/Forest       | 0.86                  | 0.08                              | 0.00        | 0.78         |
| R1 <sup>e</sup>                                                                                                                          | Emergent              | 0.04                  | 0.00                              | 0.00        | 0.04         |
| R2 <sup>e,i</sup>                                                                                                                        | Shrub/Emergent        | 0.12                  | 0.00                              | 0.06        | 0.06         |
| R3 <sup>e,i</sup>                                                                                                                        | Shrub                 | 0.02                  | 0.00                              | 0.02        | 0.00         |
| R4 <sup>e,i</sup>                                                                                                                        | Emergent              | 0.11                  | 0.00                              | 0.00        | 0.11         |
| R4 <sup>b,e,i</sup>                                                                                                                      | Forest/Emergent       | 0.11                  | 0.03                              | 0.00        | 0.08         |
| R5 <sup>e,i</sup>                                                                                                                        | Emergent              | 0.05                  | 0.00                              | 0.00        | 0.05         |
| R5 <sup>b,e,i</sup>                                                                                                                      | Forest/Emergent       | 0.07                  | 0.02                              | 0.00        | 0.05         |
| R6 <sup>e,i</sup>                                                                                                                        | Forest/Emergent       | 0.21                  | 0.05                              | 0.00        | 0.16         |
| R6 <sup>b,e,i</sup>                                                                                                                      | Emergent              | 0.09                  | 0.00                              | 0.00        | 0.09         |
| R7 <sup>e,i</sup>                                                                                                                        | Forest/Emergent       | 0.04                  | 0.04                              | 0.00        | 0.00         |
| R7 <sup>a,e,i</sup>                                                                                                                      | Emergent              | 0.04                  | 0.04                              | 0.00        | 0.00         |
| R8 <sup>e,i</sup>                                                                                                                        | Shrub/Emergent        | 0.40                  | 0.00                              | 0.20        | 0.20         |
| R9 <sup>e,i</sup>                                                                                                                        | Forest                | 0.38                  | 0.38                              | 0.00        | 0.00         |

**Table 3.1-4. Summary of wetlands disturbed during mitigation activities (continued).**

| Wetland                                | Vegetation Types      | Total Area<br>(acres) | Vegetation Type Disturbed (acres) |             |                   |
|----------------------------------------|-----------------------|-----------------------|-----------------------------------|-------------|-------------------|
|                                        |                       |                       | Forest                            | Shrub       | Emergent          |
| R9 <sup>a, c, i</sup>                  | Forest/Shrub/Emergent | 0.30                  | 0.30                              | 0.00        | 0.00              |
| R10 <sup>c, i</sup>                    | Shrub                 | 0.04                  | 0.04                              | 0.00        | 0.00              |
| R11 <sup>c, i</sup>                    | Emergent              | 0.42                  | 0.00                              | 0.00        | 0.42              |
| R12 <sup>c, i</sup>                    | Forest                | 0.03                  | 0.03                              | 0.00        | 0.00              |
| R13 <sup>c, i</sup>                    | Emergent              | 0.12                  | 0.00                              | 0.00        | 0.12              |
| R14 <sup>a, c, i</sup>                 | Shrub/Emergent        | 0.13                  | 0.13                              | 0.00        | 0.00              |
| R14 <sup>b, c, i</sup>                 | Emergent              | 0.08                  | 0.00                              | 0.00        | 0.08              |
| R15 <sup>a, c, i</sup>                 | Forest/Shrub/Emergent | 0.79                  | 0.25                              | 0.40        | 0.14              |
| R15 <sup>b, c, i</sup>                 | Forest/Emergent       | 0.25                  | 0.06                              | 0.00        | 0.19              |
| R17 <sup>c, i</sup>                    | Forest                | 0.31                  | 0.31                              | 0.00        | 0.00              |
| Waters B, D,<br>V1 and V2 <sup>g</sup> | Open Water            | 0.21                  | 0.00                              | 0.00        | 0.21 <sup>j</sup> |
| Auburn <sup>eh</sup>                   | Emergent              | 9.13                  | 0.00                              | 0.00        | 9.13              |
|                                        | <b>Subtotal</b>       | <b>25.35</b>          | <b>5.26</b>                       | <b>1.28</b> | <b>18.03</b>      |
| <b>TOTAL</b>                           |                       | <b>43.34</b>          | <b>5.82</b>                       | <b>1.93</b> | <b>35.67</b>      |

- <sup>a</sup> Temporary impacts will be associated with restoration activities at the Vacca Farm site. Wetlands A1 and farmed wetland (FW) 11 extend off-site. Values given are for the portion of the wetland occurring on site.
- <sup>b</sup> Temporary impacts result from constructing temporary roads to provide access to the mitigation site.
- <sup>c</sup> Excavation activities in wetlands at off-site mitigation area to increase habitat diversity/complexity will include construction of temporary roads to access the interior portion of the site to conduct monitoring and maintenance activities, and creation of approximately 3 acres of temporary staging area.
- <sup>d</sup> Maximum of 2.20 acres of existing off-site ditches and FW will be converted to a wetland drainage channel that connects the mitigation site to the 100-year floodplain of the Green River.
- <sup>e</sup> Enhancements activities in these wetlands may include excavation for temporary irrigation systems.
- <sup>f</sup> Planting and removal of culverts will occur in the wetland located at the Tyee Valley Golf Course.
- <sup>g</sup> Existing drain tiles will be removed and natural wetland topography restored.
- <sup>h</sup> Mowing, discing, and planting will occur in an existing low quality emergent wetland.
- <sup>i</sup> These wetlands are in the Miller Creek buffer.

The calculated permanent impacts to wetlands (18.37 acres) also include about 2.4 acres of indirect wetland impacts (see Table 3.1-1) that could occur in certain locations where there are changes to wetland hydrology, shading, or fragmentation resulting in loss of wetland functions (Parametrix 2001b). While these indirect impacts could result in the loss of some wetland functions from an area, they may not necessarily remove all functions. For example, where the SASA bridge crosses Wetland 52, shading will eliminate wetland vegetation and therefore, some wildlife habitat function will be lost from this wetland. The wildlife corridor and hydrologic functions provided by this wetland will remain. In other areas, if wetland hydrology were reduced or eliminated, vegetation would remain and habitat or other functions would continue to be provided. Even though indirect impacts will not, in all cases, eliminate all wetland functions, these impacts are mitigated at ratios in excess of 3:1.

Other indirect impacts to wetlands that could affect their function include noise and human disturbance, changes in water quality impacts, and changes in surface hydrology. These impacts could alter or reduce the level of some functions, but would not eliminate the wetlands themselves or their functions. These impacts are also mitigated by this plan because, in most cases, land use

conditions that have degraded these wetlands are removed, and restoration actions are implemented to enhance wetland function (Parametrix 2001b).

#### **3.1.4 Watershed Impacts**

The wetland impacts, minimum amount of known wetlands, and wetland restoration actions are summarized by the on-site sub-watersheds of Water Resource Inventory Area (WRIA) 9 in Table 3.1-5. The Master Plan Update improvements result in about 3.3 to 4.0 percent of wetlands in these sub-basins. In all cases, because of the physical attributes of the mitigated wetlands, including their hydrologic connectivity, the mitigation provides Category III wetlands and buffers. These losses are compensated on-site by mitigation described in Sections 4, 5, and 7.

### **3.2 STREAMS**

Impacts to streams resulting from Master Plan Update improvements include filling approximately 980 ft of Miller Creek (Figure 3.2-1). Filling a portion of Miller Creek to accommodate the runway embankment and road relocations will result in a loss of surface water conveyance that must be replaced through mitigation (see Section 5.2). The section of Miller Creek to be relocated, adjacent to the Vacca Farm site, is an artificial (ditched) stream channel constructed in silty soils. The natural stream was moved to its present location and constructed as a straight channel to improve the area for farming; consequently, it provides limited fish habitat.

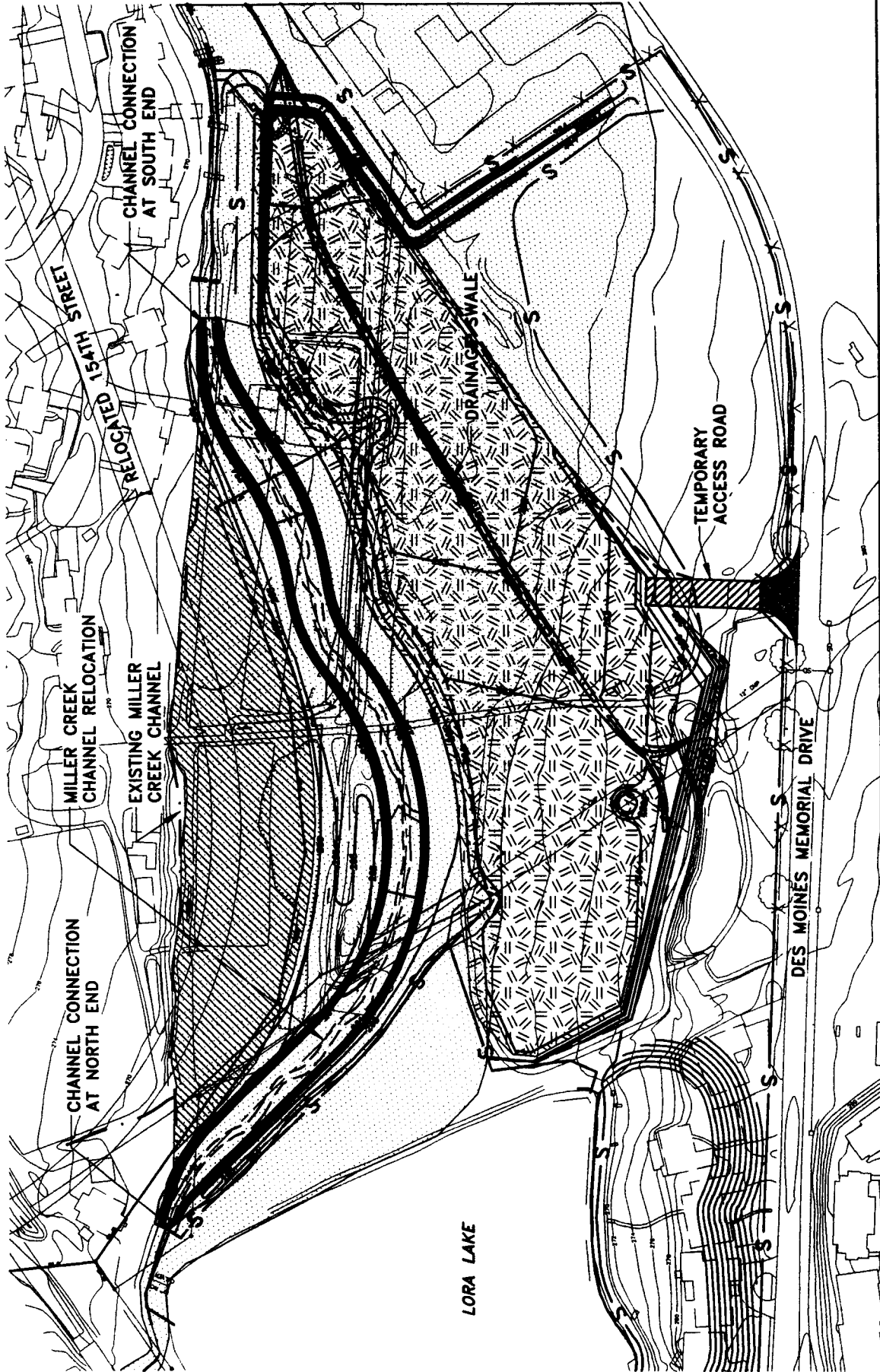
### **3.3 FLOODPLAINS**

Fill for the proposed Master Plan Update improvements will result in the loss of approximately 5.24 acre-ft of floodplain storage where the segment of Miller Creek will be relocated (see Figures 1.3-2 and 3.2-1). Without mitigation, encroachment on the floodplain would result in loss of flood storage capacity and potential increases in flooding in downstream areas.

**Table 3.1-5. Changes in wetland and aquatic habitat areas in the Miller, Walker, and Des Moines Creek basins (WRIA 9).**

| <b>Watershed and Sub-Area</b>                   | <b>Area</b>   | <b>Impact</b> | <b>Restoration</b> |
|-------------------------------------------------|---------------|---------------|--------------------|
| <b>Miller Creek Basin</b>                       |               |               |                    |
| Arbor Lake                                      | 3.7           | 0.00          | 0.00               |
| Lake Burien                                     | 30            | 0.00          | 0.00               |
| Riparian wetlands near S. 144 <sup>th</sup> Way | 2.00          | 0.00          | 0.00               |
| Tub Lake Peatland/N. SeaTac Park Wetlands       | 21.01         | 0.00          | 0.00               |
| North Employee Parking Lot Wetlands 1,2         | 0.81          | 0.00          | 0.00               |
| Des Moines Way Nursery                          | 0.86          | 0.00          | 2.00               |
| Runway Safety Areas/North End                   | 27.84         | 2.75          | 0.40               |
| Vacca Farm Mitigation                           | 8.07          | 0.00          | 6.60               |
| Miller Creek Riparian                           | 1.05          | 1.05          | 0.03               |
| Third Runway Embankment                         | <u>15.74</u>  | <u>11.03</u>  | <u>1.2</u>         |
| <b>Total</b>                                    | <b>111.08</b> | <b>14.83</b>  | <b>10.23</b>       |
| <b>NET CHANGE<sup>a</sup>: -4.5 acres</b>       | <b>-4.0%</b>  |               |                    |
| <b>Walker Creek Basin</b>                       |               |               |                    |
| Wetland 43                                      | 33.43         | 0.00          | 0.00               |
| Wetland 44                                      | 3.08          | 0.54          | 0.28               |
| Miscellaneous                                   | <u>0.99</u>   | <u>0.99</u>   | <u>0.00</u>        |
| <b>Total</b>                                    | <b>37.5</b>   | <b>1.53</b>   | <b>0.28</b>        |
| <b>NET CHANGE<sup>a</sup>: -1.25 acres</b>      | <b>-3.3%</b>  |               |                    |
| <b>Des Moines Creek Basin</b>                   |               |               |                    |
| WSDOT Wetland B                                 | 6.60          | 0.00          | 0.00               |
| Bow Lake Wetlands                               | 25            | 0.00          | 0.00               |
| SASA Area                                       | 7.22          | 2.95          | 0.17               |
| Borrow Areas                                    | 24.24         | 1.04          | 0.00               |
| Tyee Valley Golf Course                         | <u>38.51</u>  | <u>0.07</u>   | <u>0.00</u>        |
| <b>Total</b>                                    | <b>101.57</b> | <b>4.06</b>   | <b>0.17</b>        |
| <b>NET CHANGE<sup>a</sup>: -3.89 acres</b>      | <b>-3.8%</b>  |               |                    |
| <b>TOTAL</b>                                    | <b>250.15</b> | <b>20.42</b>  | <b>10.68</b>       |
| <b>NET CHANGE -9.74 acres</b>                   | <b>-3.9%</b>  |               |                    |

<sup>a</sup> Estimates of changes exceed actual changes, because they do not include riparian wetlands outside the project area, wetlands at the mouths of Miller, Walker, and Des Moines Creeks, or other wetlands that are likely to be present on undeveloped or developed areas. See Tables 4.1-2 and 4.1-3 in Section 4 for a summary of the mitigation planned to compensate for wetland functions associated with these changes.



**Figure 3.2-1  
Miller Creek  
Relocation and Floodplain  
Grading at the Vacca Farm Site**

FILE: 291203\_13  
DATE: 11/16/01

LEGEND:

|  |                       |                          |
|--|-----------------------|--------------------------|
|  | Existing Floodplain   | (Elevation ±284.5)       |
|  | Impacted Floodplain   | 8,455 c.y. (5.24 ac-ft.) |
|  | Floodplain Excavation | 9,589 c.y. (5.94 ac-ft.) |
|  | Proposed Grade        |                          |

—284—

0 75 150  
SCALE IN FEET

▲

Flooding impacts in the Miller Creek basin as a result of the project are unlikely because required mitigation will include adherence to floodplain development standards and floodway management requirements of FEMA, FAA, Ecology, King County, and the City of SeaTac. Floodplain development standards prohibit any reduction in the 100-yr floodplain or base flood storage volume. Compensatory mitigation is required for any proposed filling of the 100-yr floodplain to achieve no net loss in flood storage capacity.

Temporary floodplain impacts during construction could include temporary fill for construction access roads and construction in the floodplain as floodplain and wetland mitigation plans are implemented. Since construction will occur during the dry season when the probability of a significant flood is very low, this potential impact is not significant.

### **3.4 DRAINAGE CHANNELS**

Construction of the runway embankment will fill approximately 1,290 ft of three drainage channels near 12<sup>th</sup> Avenue (Figure 3.4-1) and portions of an agricultural drainage channel at the Vacca Farm site. Portions of Channels A, W, and B will be filled to accommodate the embankment for the third runway (see Figure 3.4-1). These channels do not contain fish habitat. Their primary function is to convey roadside runoff and seepage flow from the hill slopes to the riparian wetlands adjacent to Miller Creek. Without mitigation, filling these channels could result in reduced base flows reaching Miller Creek; however, mitigation actions to reroute seepage and stormwater flow to the riparian wetlands will continue to provide comparable base flow to the stream. Because appropriate mitigation actions will be implemented (see Section 5.2.3), no impacts to Miller Creek will occur from filling these drainage channels.

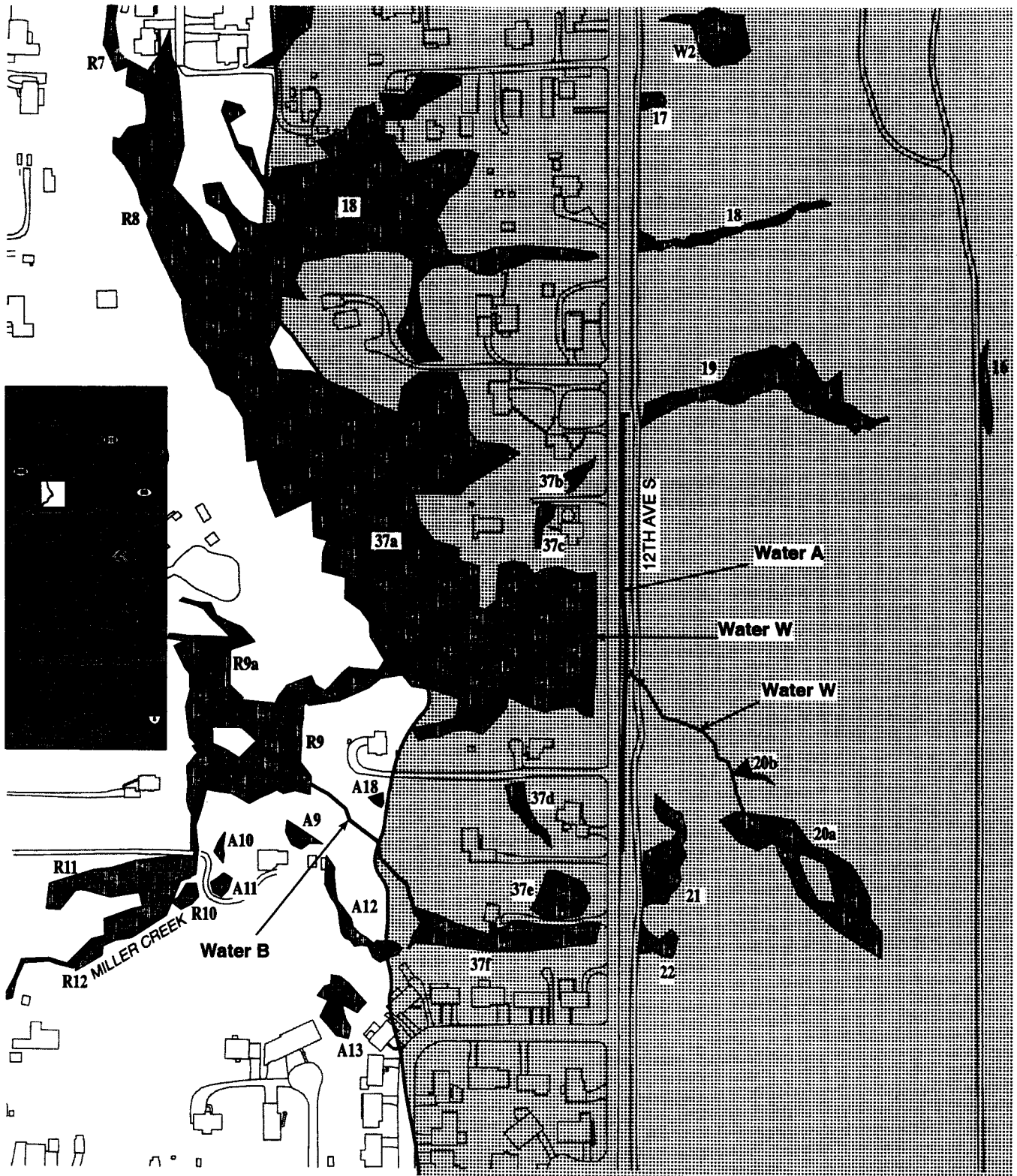
A drainage ditch located in the Vacca Farm site (see Figure 2.1-4) parallels Miller Creek for approximately 800 ft. The ditch, which is part of Wetland A1, provides positive drainage for the adjacent farmland, connecting to Miller Creek near South 156<sup>th</sup> Way. A portion of the channel (approximately 400 ft) would be restored to natural wetland grades and vegetation.

### **3.5 WATER QUANTITY AND WATER QUALITY**

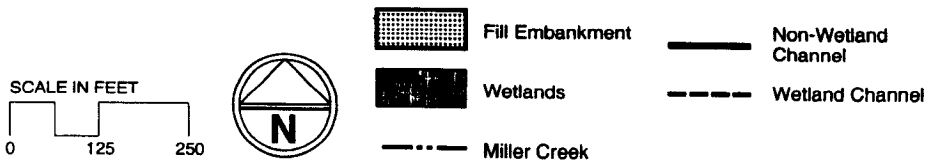
The permanent activities associated with implementation of the Master Plan Update improvements will include grading, filling, paving new streets and runways, and constructing new buildings. These improvements will increase impervious surface areas in the Miller Creek and Des Moines Creek watersheds. Details describing stormwater quality and quantity can be found in Section 6.

Additional impervious surfaces could further increase stormwater runoff rates and volumes, and pollutant loads to the receiving streams. Unless mitigated, changes in runoff are expected to increase flooding and erosion, and degrade instream habitat and water quality in Miller Creek downstream of stormwater inputs from the improved areas. The impervious surface areas could reduce the groundwater recharge occurring in the development footprints, resulting in less groundwater seepage during low-flow periods.

Operational impacts to water quality from fuel spills that could occur where fuel is routinely handled are avoided by routing runoff to the IWS through an established drainage system. Such spills do not enter the stormwater system, and thus do not discharge to wetlands, streams, or other



Port of Seattle/Natural Resource Mitigation Plan/556-2912-001/01(03) 11/01 (K)



**Figure 3.4-1  
Location of Drainage  
Channel Impacts in  
the Miller Creek Basin**



surface waters. Emergency fuel spills that occur outside the fuel handling areas could enter the stormwater drainage system (SDS), where they can be controlled and treated through emergency actions.

In the Miller Creek basin, Master Plan Update improvement projects will result in a net increase of 105.6 acres<sup>10</sup> of impervious surface area, increasing the overall impervious area in the basin by about 1 percent above the existing baseline condition (about 23 percent of impervious surface [Parametrix 2000a, 2001a]). In the Walker Creek Basin, Master Plan Update improvements will result in an increase of 6.2 acres. In the Des Moines Creek Basin, Master Plan Update improvements will result in an increase of 128.2 acres of impervious surface, increasing the overall impervious area in the basin by about 4 percent above the existing base condition (approximately 32 percent impervious [Parametrix 2000a, 2001a]). A total of 417 acres will drain to the IWS under future conditions.

The new impervious surfaces could increase stormwater runoff rates (FAA 1996) and volumes. Unless mitigated, changes in runoff are expected to increase flooding and erosion and degrade instream habitat and water quality in Des Moines and Miller Creeks downstream of stormwater inputs from the improved areas. Chinook salmon (*Oncorhynchus tshawytscha*) critical habitat in the estuaries of Miller and Des Moines Creeks will not be directly altered by runoff from new impervious surfaces in the Master Plan Update improvements. In addition, existing hydrologic impacts from existing impervious surfaces will be mitigated.

The impacts of these actions are further discussed in the project Environmental Impact Statement (EIS) and *Comprehensive Stormwater Management Plan* (Parametrix 2000a, 2001a). Without the proposed mitigation identified in Section 6.1 of this report, this new impervious surface could cause increased flooding, erosion, and habitat and water quality degradation in the Miller and Des Moines Creek watersheds. The *Comprehensive Stormwater Management Plan* summarizes the 1994 base watershed drainage area conditions and future conditions for Miller and Des Moines Creeks (Parametrix 2000a, 2001a).

---

<sup>10</sup> The net change in impervious area includes a reduction of approximately 50 acres of impervious surfaces (streets, driveways, and rooftops) that will result when existing houses and streets are removed in the acquisition area. Demolition in these areas is ongoing and is expected to be completed by 2002. Over 75 acres of the acquisition area is preserved as on-site mitigation.



#### **4. SUMMARY OF MITIGATION, MONITORING, MAINTENANCE, AND CONTINGENCIES**

This section provides an overview of the mitigation, performance monitoring, maintenance, and contingency actions incorporated into the Master Plan Update improvements to mitigate adverse project impacts to wetlands, streams, floodplains, and drainage channels. In addition, the Port has made extensive efforts throughout the Master Plan Update planning process to avoid, minimize, and rectify, as well as compensate for, adverse impacts.

The mitigation strategy (summarized in Section 4.1) focuses on compensatory mitigation actions to replace wetland and stream functions impacted by the Master Plan Update improvements (Parametrix 2001b). Key elements of the compensatory mitigation plan are targeted at restoring functions on-site and include sediment and nutrient retention (water quality), organic carbon production and export, surface water storage (floodwater detention and storage), and aquatic habitat functions (e.g., instream aquatic habitat and riparian habitat), as discussed in Section 4.1.

Section 4.2 discusses how mitigation sites and the beneficial ecological functions to be established on them will be protected in the long term. This section describes the establishment and enhancement of protective buffers, the adequacy of buffers to protect the desired functions from potential impacts, and long-term protection by establishing restrictive covenants.

The Port's mitigation plans include enforceable performance standards (Sections 5.1, 5.2, and 7) and a long-term monitoring plan, described in Section 4.2. Monitoring and evaluation of the projects against these performance standards will allow the success of mitigation projects to be evaluated by the Port and regulatory agencies and provide assurance that the ecological benefits of the mitigation are ultimately achieved. The monitoring section discusses the adaptive management approach that the Port will use to evaluate performance of the mitigation site and implement contingency measures if performance standards are not met. In addition, Section 4.3 summarizes the monitoring methods to evaluate hydrology, vegetation and wildlife habitat on the mitigation sites, the monitoring and control of hazard wildlife (USDA 2000), and an integrated weed management strategy for managing invasive non-native plant species.

Mitigation types proposed by the Port in this mitigation plan meet the mitigation criteria defined by ACOE (2001) in Regulatory Guidance Letter (RGL) 01-1. These mitigation types include: establishment (at Auburn); restoration-rehabilitation (on-site and at Auburn); restoration-re-establishment (on-site); enhancement (on-site and at Auburn); and protection (on-site).

##### **4.1 MITIGATION STRATEGY**

The primary strategy for mitigating natural resource impacts was to design the least damaging practical alternative to avoid and minimize wetland and stream impacts. Where impacts to wetlands and streams were found to be unavoidable, compensatory mitigation is proposed such that there is no net loss of wetland functions or area. The functions targeted in the design of the mitigation projects, were based on the functions impacted by wetland loss (see Parametrix 2001b) and by designing the mitigation sites with the habitat or other attributes required to provide the desired ecological functions.

The mitigation plan also proposes mitigation areas in excess of impact areas to account for the temporal losses of wetland function (losses of function over time) from both temporary and permanent impacts. The potential uncertainty in mitigation success is also recognized by the increased acreage of mitigation.<sup>11</sup> The comprehensive approach that the Port has taken to avoid, minimize, rectify, and compensate for impacts to wetlands and aquatic resources is summarized in Table 4.1-1, Figure 4.1-1, and Figure 4.1-2. The compensatory wetland and stream mitigation projects are summarized in Table 4.1-2. The recommended preference for selecting wetland mitigation sites in Washington is as follows: (1) on-site and in-kind; (2) off-site, within the watershed, and in-kind; (3) off-site, out of the watershed, and in-kind; and (4) off-site, out of the watershed, and out-of-kind (Ecology 1990). The Port's proposed mitigation for wetland impacts has followed these recommendations. Therefore, most mitigation for impacts to wetland, stream, and floodplain functions are on-site and in-kind, occurring within the Miller and Des Moines Creek basins.

On-site mitigation actions in WRIA 9 are summarized in this Section 4.1.1, and described in detail in Section 5 (for aquatic habitat, floodplain, stream, and wetland restoration) and Section 6 (for water quality and water quantity). Off-site wetland mitigation in WRIA 9 is proposed to replace avian wildlife habitat and is summarized in Section 4.1.2, and described in detail in Section 7.

Mitigation for the loss of ecological functions provided by wetlands unavoidably impacted meets or exceeds requirements to mitigate for lost wetland area and functions (Table 4.1-3 and Table 4.1-4). In Miller and Des Moines Creek basins, the Port proposes to restore and enhance non-avian habitat wetland functions on over 34.3 acres of wetlands and aquatic habitat, providing mitigation for impacts to 18.37 acres. Buffers associated with restored streams and wetlands in the basin will total approximately 55 acres.<sup>12</sup> Off-site mitigation at the Auburn mitigation site will consist of creating approximately 30 acres of new wetlands, enhancing 19.5 acres of existing emergent wetlands, and creating approximately 15.9 acres of forest and buffer habitat.

Additional mitigation to replace ecological functions will be provided in the form of funding for stream enhancement and provision of extensive buffers and on-site water quality and water quantity controls on stormwater runoff. These mitigation actions provide further assurance that all wetland functions potentially impacted are replaced, and there is significant ecological restoration of the impacted watersheds.

---

<sup>11</sup> The uncertainty in the ultimate success of the mitigation projects is greatly reduced by careful design that is based on several years of observations of mitigation site conditions. Uncertainties are further reduced by requirements for a 15-year monitoring period, identification of enforceable performance standards, planning of contingency options, and an adaptive management approach to monitoring the projects.

<sup>12</sup> The size and adequacy of the buffers proposed to protect existing and proposed functions at mitigation sites are discussed in Section 4.2 and as part of the detailed description of each project.

**Table 4.1-1. Summary of mitigation actions and their relation to National Environmental Policy Act, State Environmental Policy Act, and Clean Water Act mitigation sequencing requirements.**

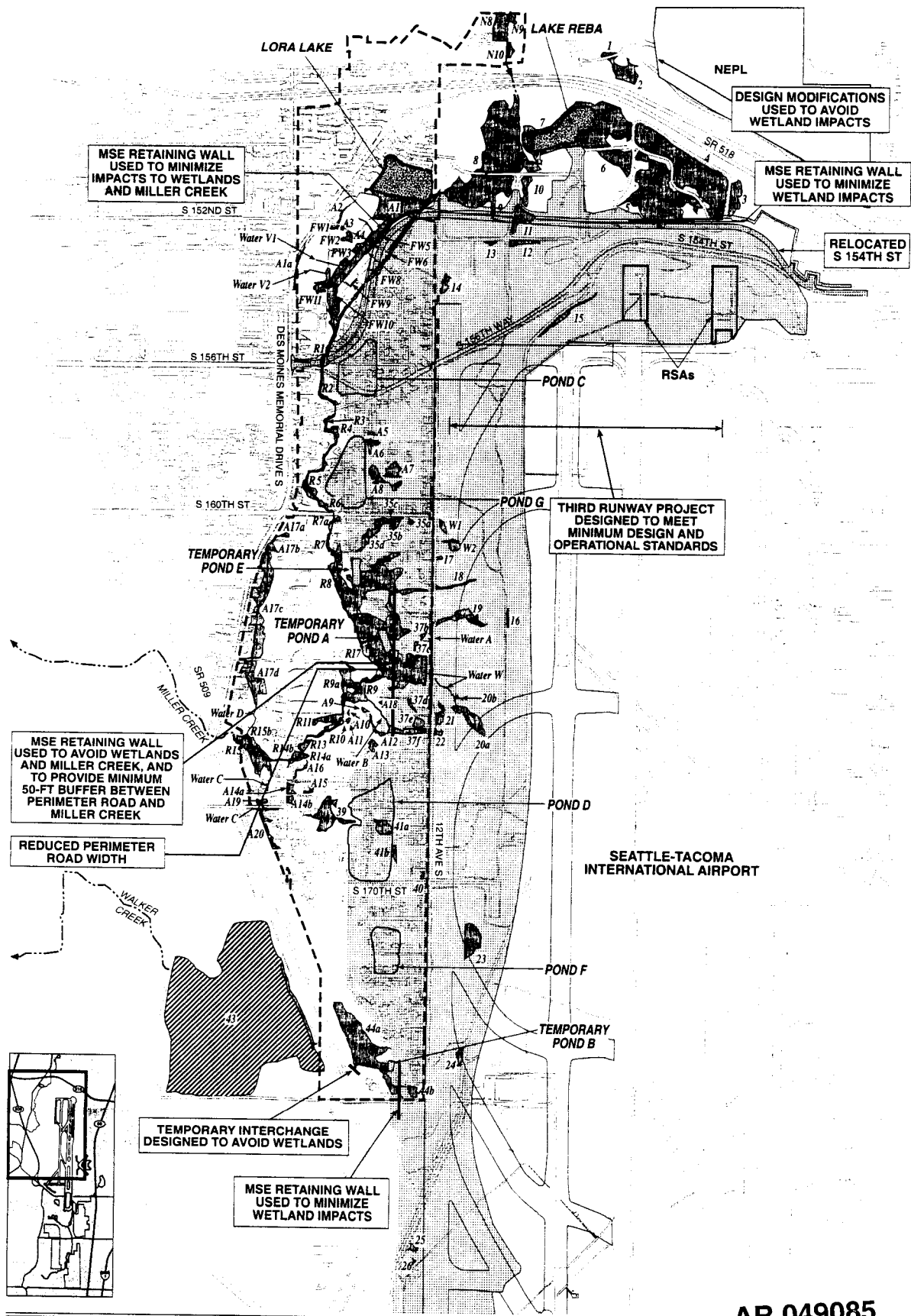
| Mitigation Requirement                                                                             | Proposed Mitigation Action                                                                                                                                                                                                                                                                                                                                                                                                                                                                                                                                                                                                                                                                                                                                                       |
|----------------------------------------------------------------------------------------------------|----------------------------------------------------------------------------------------------------------------------------------------------------------------------------------------------------------------------------------------------------------------------------------------------------------------------------------------------------------------------------------------------------------------------------------------------------------------------------------------------------------------------------------------------------------------------------------------------------------------------------------------------------------------------------------------------------------------------------------------------------------------------------------|
| <b>New Third Runway</b>                                                                            |                                                                                                                                                                                                                                                                                                                                                                                                                                                                                                                                                                                                                                                                                                                                                                                  |
| Avoid the impact by not taking a certain action or parts of an action.                             | <p>Avoid fill in wetlands and Miller Creek by designing the runway to meet the minimum operational, engineering, safety, and maintenance standards.</p> <p>Locate, where feasible, permanent stormwater detention ponds in uplands. Avoid excavation within 50 ft of Category II and III wetlands in Borrow Area 3.</p> <p>Avoid wetlands in Borrow Area 1 where practical.</p> <p>Construct retaining walls at the northwest end of the runway to reduce impacts to Miller Creek and Category II wetlands (Wetlands 8, 9, and A1) located at the north end of the project.</p> <p>Install a retaining wall near the west-central portion of the embankment to reduce impacts to Category II Wetlands 18 and 37 and avoid relocating a second segment of Miller Creek.</p>       |
| Minimize the impact by limiting the degree or magnitude of the action.                             | <p>Place a retaining wall near the southwest end of the runway to reduce impact to a Category II wetland (Wetland 44).</p> <p>Design Borrow Areas 1 and 3 with a 150- to 200-ft setback from Des Moines Creek to minimize potential impact to the stream and its buffers.</p> <p>Implement stormwater pollution prevention plans (SWPPPs) prior to any construction project.</p>                                                                                                                                                                                                                                                                                                                                                                                                 |
| Rectify the impact by restoring the affected environment.                                          | <p>Remove temporary stormwater management facilities located in wetlands following construction. These disturbed areas will be restored to pre-construction conditions</p>                                                                                                                                                                                                                                                                                                                                                                                                                                                                                                                                                                                                       |
| Reduce the impact over time by preservation and maintenance actions during the life of the action. | <p>Establish and enhance a 100-ft average (minimum 50-ft) forested buffer on both banks of Miller Creek to reduce potential construction and operational impacts to riparian wetlands and aquatic resources.</p> <p>Maintain hydrology to wetlands by directing seepage water from the embankment to wetlands downslope of the embankment (Hart Crowser 2000c, 2001b; Appendix Q).</p> <p>Provide water quantity and water quality mitigation to protect aquatic habitat in Miller Creek from stormwater impacts during operation.</p> <p>Reduce temporal losses from construction by adding additional mitigation (Wetland A17).</p>                                                                                                                                            |
| Compensate for the impact by replacing, enhancing, or providing substitute resources.              | <p>Restore the Vacca Farm wetland/floodplain area, including fill removal, creating new floodplain, restoring wetland hydrology and vegetation, and providing protective buffers.</p> <p>Restore and enhance Miller Creek instream habitat in the Vacca Farm area.</p> <p>Restore natural channel morphology to a ditched and channelized reach of the stream.</p> <p>Enhance instream habitat and place LWD in Miller Creek and enhance adjacent riparian buffers between Vacca Farm and Des Moines Memorial Drive.</p> <p>Enhance wetlands along Miller Creek within the 100-ft buffer by restoring native vegetation and removing invasive non-native species.</p> <p>Construct replacement drainage channels west of the embankment to replace filled drainage channels.</p> |

**Table 4.1-1. Summary of mitigation actions and their relation to National Environmental Policy Act, State Environmental Policy Act, and Clean Water Act mitigation sequencing requirements (continued).**

| Mitigation Requirement                                                                             | Proposed Mitigation Action                                                                                                                                                                                                                                                                                                                                                                                                                                                                                                                                                                                                                                                                                                                                                                                                                                                                                                                                                                                                                                                                                                                                                                                   |
|----------------------------------------------------------------------------------------------------|--------------------------------------------------------------------------------------------------------------------------------------------------------------------------------------------------------------------------------------------------------------------------------------------------------------------------------------------------------------------------------------------------------------------------------------------------------------------------------------------------------------------------------------------------------------------------------------------------------------------------------------------------------------------------------------------------------------------------------------------------------------------------------------------------------------------------------------------------------------------------------------------------------------------------------------------------------------------------------------------------------------------------------------------------------------------------------------------------------------------------------------------------------------------------------------------------------------|
|                                                                                                    | <p>Restore wetlands on the Tyee Valley Golf Course, including restoring wetland vegetation to reduce wildlife hazards and improve water quality.</p> <p>Restore and enhance wetlands, buffers, and Miller Creek at the Des Moines Way Nursery site.</p> <p>Reduce temporal losses by providing wetland additional enhancement as mitigation for temporary impacts.</p> <p>Enhance aquatic habitat in Des Moines Creek by restoring a 100-ft-wide forest/shrub buffer along the stream between the Northwest Ponds and the proposed SR 509 right-of-way (ROW).</p> <p>Provide a \$300,000 trust fund to enhance fisheries habitat in Miller and Des Moines Creeks.</p> <p>Create replacement wetlands at an off-site location for the loss of wildlife habitat within 10,000 ft of the airport runways.</p> <p>Monitor mitigation projects for compliance with performance standards and other permit conditions.</p> <p>Monitor stormwater runoff for compliance with National Pollutant Discharge Elimination System (NPDES) requirements.</p> <p>Monitor remaining wetlands downslope of the new embankment (i.e., between the embankment and Miller Creek) for indirect impacts to wetland hydrology.</p> |
| <b>Runway Safety Areas</b>                                                                         |                                                                                                                                                                                                                                                                                                                                                                                                                                                                                                                                                                                                                                                                                                                                                                                                                                                                                                                                                                                                                                                                                                                                                                                                              |
| Avoid the impact by not taking a certain action or parts of an action.                             | Construct retaining walls to support relocated South 154 <sup>th</sup> Street and avoid permanent fill in Wetlands 3 and 4.                                                                                                                                                                                                                                                                                                                                                                                                                                                                                                                                                                                                                                                                                                                                                                                                                                                                                                                                                                                                                                                                                  |
| Minimize the impact by limiting the degree or magnitude of the action.                             | Construct retaining walls to support relocated South 154 <sup>th</sup> Street and reduce permanent fill and minimize temporary impacts in Wetland 5.                                                                                                                                                                                                                                                                                                                                                                                                                                                                                                                                                                                                                                                                                                                                                                                                                                                                                                                                                                                                                                                         |
| Rectify the impact by restoring the affected environment.                                          | Implement SWPPPs prior to any construction project.<br>Restore wetland areas temporarily impacted by required TESC facilities and provide additional mitigation (Wetland A17) to reduce temporal losses.                                                                                                                                                                                                                                                                                                                                                                                                                                                                                                                                                                                                                                                                                                                                                                                                                                                                                                                                                                                                     |
| Reduce the impact over time by preservation and maintenance actions during the life of the action. | Provide water quantity and water quality mitigation to protect wetlands and other receiving waters from stormwater impacts during operation.                                                                                                                                                                                                                                                                                                                                                                                                                                                                                                                                                                                                                                                                                                                                                                                                                                                                                                                                                                                                                                                                 |
| Compensate for the impact by replacing, enhancing, or providing substitute resources.              | Restore the Vacca Farm wetland/floodplain area to provide hydrologic and water quality functions.<br>Create replacement wetlands for wildlife habitat (greater than 10,000 ft from the airport runways at the Auburn site).                                                                                                                                                                                                                                                                                                                                                                                                                                                                                                                                                                                                                                                                                                                                                                                                                                                                                                                                                                                  |
| Monitor the impact and take appropriate corrective actions.                                        | Monitor remaining wetlands for indirect impacts to hydrology.<br>Monitor mitigation projects for compliance with performance standards and other permit conditions.                                                                                                                                                                                                                                                                                                                                                                                                                                                                                                                                                                                                                                                                                                                                                                                                                                                                                                                                                                                                                                          |
| <b>South Aviation Support Area</b>                                                                 |                                                                                                                                                                                                                                                                                                                                                                                                                                                                                                                                                                                                                                                                                                                                                                                                                                                                                                                                                                                                                                                                                                                                                                                                              |
| Avoid the impact by not taking a certain action or parts of an action.                             | Monitor stormwater runoff for compliance with NPDES requirements.<br><br>Design the SASA footprint to avoid relocation of Des Moines Creek.<br>Temporary impacts to Des Moines Creek and Wetland 52 are not anticipated.                                                                                                                                                                                                                                                                                                                                                                                                                                                                                                                                                                                                                                                                                                                                                                                                                                                                                                                                                                                     |

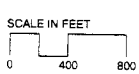
**Table 4.1-1. Summary of mitigation actions and their relation to National Environmental Policy Act, State Environmental Policy Act, and Clean Water Act mitigation sequencing requirements (continued).**

| <b>Mitigation Requirement</b>                                                                      | <b>Proposed Mitigation Action</b>                                                                                                                                                                                                                                                                                                                                                                                                                                                                            |
|----------------------------------------------------------------------------------------------------|--------------------------------------------------------------------------------------------------------------------------------------------------------------------------------------------------------------------------------------------------------------------------------------------------------------------------------------------------------------------------------------------------------------------------------------------------------------------------------------------------------------|
| Minimize the impact by limiting the degree or magnitude of the action.                             | Design the SASA to avoid direct impacts to forested wetland (Wetland 52) that provides groundwater discharge functions.                                                                                                                                                                                                                                                                                                                                                                                      |
| Reduce the impact over time by preservation and maintenance actions during the life of the action. | Design water quantity and water quality mitigation to protect wetlands from stormwater impacts.                                                                                                                                                                                                                                                                                                                                                                                                              |
| Rectify the impact by restoring the affected environment.                                          | Restore potential temporary impacts to Des Moines Creek and Wetland 52.                                                                                                                                                                                                                                                                                                                                                                                                                                      |
| Compensate for the impact by replacing, enhancing, or providing substitute resources.              | Restore wetlands on the Tyee Valley Golf Course to provide water quality and hydrologic benefits to replace lost wetland functions.<br>Construct replacement wetlands for wildlife habitat (greater than 10,000 ft from the airport runways at the Auburn site).<br>Enhance and restore a 100-ft-wide forest/shrub buffer along Des Moines Creek to enhance aquatic habitat.<br>Provide a trust fund for enhancement of fisheries habitat of Des Moines Creek.                                               |
| Monitor the impact and take appropriate corrective actions.                                        | Monitor Wetland 52 for indirect impacts to wetland hydrology.<br>Monitor mitigation projects for compliance with performance standards and other permit conditions.<br>Monitor stormwater runoff for compliance with NPDES requirements.                                                                                                                                                                                                                                                                     |
| <b>On-site Borrow Source Areas</b>                                                                 |                                                                                                                                                                                                                                                                                                                                                                                                                                                                                                              |
| Avoid the impact by not taking a certain action or parts of an action.                             | Redesign development areas within Borrow Areas 1 and 3 to avoid excavation of 12 wetlands (Wetlands B1, B4, B5, B6, B7, B9, B10, B15a, B15b, 29, 30, and 48).                                                                                                                                                                                                                                                                                                                                                |
| Minimize the impact by limiting the degree or magnitude of the action.                             | Establish a 150- to 200-ft buffer between Borrow Area 1 and Des Moines Creek to avoid impacts to stream hydrology and riparian buffers.<br>Follow a TESC Plan to eliminate siltation reaching wetlands or Des Moines Creek from excavation activities.<br>Establish final surface grades in Borrow Area 1, and construct interceptor swale system in Borrow Area 3, to direct surface water runoff and groundwater seepage to wetlands near borrow areas, and minimize and avoid indirect hydrology impacts. |
| Reduce the impact over time by preservation and maintenance actions during the life of the action. | Maintain BMPs throughout the operating period to ensure adjacent wetlands will be protected from adverse construction-related activities.<br>Preserve wetlands and buffers adjacent to Borrow Area 3.                                                                                                                                                                                                                                                                                                        |
| Compensate for the impact by replacing, enhancing, or providing substitute resources.              | Restore wetlands on the Tyee Valley Golf Course to compensate for water quality and hydrologic support functions impacted in the Des Moines Creek basin.<br>Enhance a 100-ft-wide forest/shrub buffer along Des Moines Creek to enhance aquatic habitat.<br>Provide a trust fund for enhancement of fisheries habitat of Des Moines Creek.                                                                                                                                                                   |
| Monitor the impact and take appropriate corrective actions.                                        | Monitor Wetlands B1, B4, B5, B6, B7, B9, B10, B15a, B15b, 29, 30, and 48 for potential indirect impacts to wetland hydrology from excavation activities.<br>Monitor stormwater runoff and TESC for compliance with NPDES requirements.                                                                                                                                                                                                                                                                       |



AR 049085

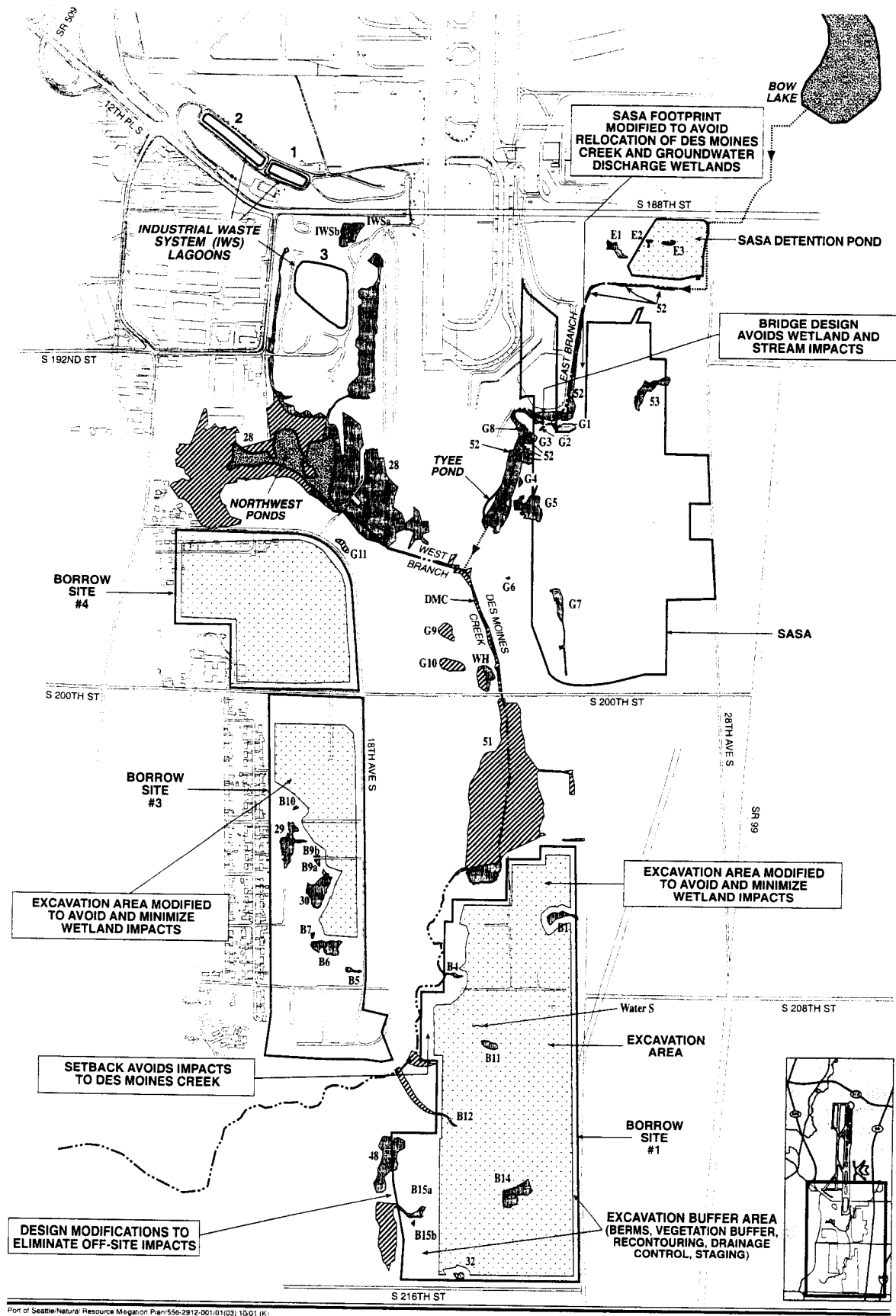
Port of Seattle/Natural Resource Mitigation Plan/556-2912-001(01/03) 11/01 (K)



- Wetlands not Verified by ACOE
- Delineated Wetlands Verified by ACOE
- Stream
- Acquisition Area Boundary
- Water Features
- Construction Area (Fill and Grading for Third Runway, Runway Safety Areas, and S 154th Street Relocation)
- Wetland Number

**Figure 4.1-1**  
Avoidance of Wetland and Stream Impacts in the Miller Creek Basin





Port of Seattle-Natural Resource Mitigation Plan/556-2912-001/01(03) 1001 (K)

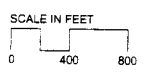
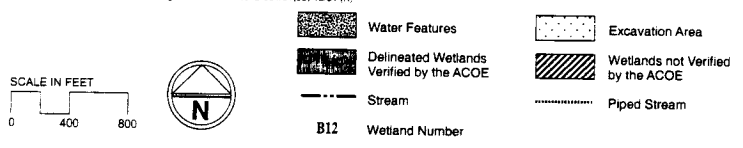


Figure 4.1-2  
Avoidance of Wetland and Stream Impacts in the Des Moines Creek Basin

AR 049086

**Table 4.1-2. Summary of compensatory mitigation (on and off site) for watershed, wetland, and stream impacts at Seattle-Tacoma International Airport.**

| Impact                                                                                                                                                   | Mitigation Action                                                                                                             | Target Functions to Replace                                            | Explanation and Key Attributes that Provide Target Functions <sup>a</sup>                                                                                                                                                                                                                                                                                                                                                                                                                              |
|----------------------------------------------------------------------------------------------------------------------------------------------------------|-------------------------------------------------------------------------------------------------------------------------------|------------------------------------------------------------------------|--------------------------------------------------------------------------------------------------------------------------------------------------------------------------------------------------------------------------------------------------------------------------------------------------------------------------------------------------------------------------------------------------------------------------------------------------------------------------------------------------------|
| <b>ON-SITE MITIGATION</b>                                                                                                                                |                                                                                                                               |                                                                        |                                                                                                                                                                                                                                                                                                                                                                                                                                                                                                        |
| <b>Permanent Impacts</b>                                                                                                                                 |                                                                                                                               |                                                                        |                                                                                                                                                                                                                                                                                                                                                                                                                                                                                                        |
| Approximately 980 linear ft of Miller Creek channel will be filled to accommodate third runway embankment and South 154 <sup>th</sup> Street relocation. | Relocate approximately 1,080 ft of Miller Creek channel.<br>Enhance 450 ft of Miller Creek channel at Des Moines Way Nursery. | Fish and aquatic habitat<br>Amphibian habitat<br>Organic matter export | The channel design includes instream habitat features, including improved substrate conditions, LWD, channel diversity, and increased channel length.<br>A buffer around the new channel will be vegetated with native trees and shrubs to provide shade and organic matter inputs to the stream.                                                                                                                                                                                                      |
| Drainage channels will be filled near 12 <sup>th</sup> Avenue South to accommodate the third runway embankment.                                          | Create new permanent drainage channels.                                                                                       | Organic matter export functions<br>Groundwater exchange functions      | Approximately 1,290 ft of new permanent drainage channels will provide ecological functions by planting the channel margins with native vegetation to provide buffer functions. Functions include shade to control water temperatures and provide organic matter input.<br>The channels will be designed to connect to the embankment drainage layer material to promote groundwater discharge. Connection to wetlands and Miller Creek will promote organic matter transport and export to the creek. |
| Approximately 8,500 cy of Miller Creek floodplain will be filled to accommodate third runway embankment and South 154 <sup>th</sup> Street relocation.   | Replace lost floodplain.                                                                                                      | Flood storage                                                          | Approximately 9,600 cubic yards of soil will be excavated to suitable elevations that achieve storage of 5.94 acre-ft of floodwaters.<br>Suitable grades and elevations will allow overbank and backwater flooding to occur in this floodplain.                                                                                                                                                                                                                                                        |

**Table 4.1-2. Summary of compensatory mitigation (on- and off-site) for watershed, wetland, and stream impacts at Seattle-Tacoma International Airport (continued).**

| Impact                                                                                                                                          | Mitigation Action                                                                                                                                                                | Target Functions to Replace                                                                                                                                                                                                                                                                                                                                                                                                                                                                                                                            | Explanation and Key Attributes that Provide Target Functions*                                                                                                                                                                                                                                                                                                                                                                                                                                                                                                                                    |
|-------------------------------------------------------------------------------------------------------------------------------------------------|----------------------------------------------------------------------------------------------------------------------------------------------------------------------------------|--------------------------------------------------------------------------------------------------------------------------------------------------------------------------------------------------------------------------------------------------------------------------------------------------------------------------------------------------------------------------------------------------------------------------------------------------------------------------------------------------------------------------------------------------------|--------------------------------------------------------------------------------------------------------------------------------------------------------------------------------------------------------------------------------------------------------------------------------------------------------------------------------------------------------------------------------------------------------------------------------------------------------------------------------------------------------------------------------------------------------------------------------------------------|
| Approximately 18.37 acres of wetland will be filled during construction of the third runway embankment and other construction-related projects. | Restore about 12.3 acres of prior converted cropland, farmed wetland, or other wetland on the Vacca Farm site to shrub-dominated wetlands (including removal of 1 acre of fill). | Nutrient and sediment trapping functions<br>Organic matter export<br>Groundwater exchange<br>Small mammal habitat<br>Reduced waterfowl habitat                                                                                                                                                                                                                                                                                                                                                                                                         | Plowed farmland will be stabilized with dense shrub and herbaceous plantings.<br>Overbank and backwater flooding will occur to promote organic matter export.<br>Subsurface drainage systems will be removed to promote natural groundwater discharge and flow patterns.<br>Hummocks vegetated with dense native vegetation in wetlands and buffers will be provided as habitat for small mammals. This attribute will be augmented with LWD in wetlands and buffers.<br>Large areas of emergent vegetation, open water, or long-term flooding that could promote waterfowl use will be avoided. |
| Restore about 2.8 acres of the Des Moines Way Nursery site to shrub dominated wetlands (Including removal of 2 acres of fill).                  | Restore wetland buffer conditions (1.81 acre) around the north and west sides of Lora Lake.                                                                                      | Fish, amphibian, and aquatic habitat<br>Organic matter export<br>Reduce wildlife attractants                                                                                                                                                                                                                                                                                                                                                                                                                                                           | Converting lawn areas to riparian buffer communities will be established by planting with native wetland and upland shrub vegetation (refer to Table 5.1-1 in Section 5).                                                                                                                                                                                                                                                                                                                                                                                                                        |
| Enhance approximately 10.25 acres of wetlands along Miller Creek                                                                                | Nutrient and sediment trapping<br>Small mammal habitat                                                                                                                           | Overhanging dense shrub vegetation will improve aquatic habitat, reduce waterfowl use of shoreline areas, and promote export of organic matter from shoreline to aquatic habitats.<br>Removal of a concrete bulkhead along the Lora Lake shoreline will improve shoreline habitat for amphibians, fish, and aquatic insects.<br>Removing structures and restoring native wetland vegetation (Table 4.1-3) will enhance riparian and other wetlands. Areas of non-native vegetation will be removed and native trees and shrubs planted in the wetland. |                                                                                                                                                                                                                                                                                                                                                                                                                                                                                                                                                                                                  |

**Table 4.1-2. Summary of compensatory mitigation (on- and off-site) for watershed, wetland, and stream impacts at Seattle-Tacoma International Airport (continued).**

| <b>Impact</b>                                                                                                                                                                                                                                                                                                                                                                                                                                                                                          | <b>Mitigation Action</b>                                                                                                                                           | <b>Target Functions to Replace</b>                                                                                    | <b>Explanation and Key Attributes that Provide Target Functions<sup>a</sup></b>                                                                                                                                                                                                                                                                                                                                                                                                                          |
|--------------------------------------------------------------------------------------------------------------------------------------------------------------------------------------------------------------------------------------------------------------------------------------------------------------------------------------------------------------------------------------------------------------------------------------------------------------------------------------------------------|--------------------------------------------------------------------------------------------------------------------------------------------------------------------|-----------------------------------------------------------------------------------------------------------------------|----------------------------------------------------------------------------------------------------------------------------------------------------------------------------------------------------------------------------------------------------------------------------------------------------------------------------------------------------------------------------------------------------------------------------------------------------------------------------------------------------------|
| <p><b>Temporary Impacts</b><br/>Construction of temporary stormwater management ponds and other projects may temporarily impact up to 2.05 acres of wetland.</p>                                                                                                                                                                                                                                                                                                                                       | <p>Restore wetlands on the Tye Valley Golf Course.</p>                                                                                                             | <p>Nutrient and sediment trapping<br/>Organic matter export<br/>Reduce waterfowl habitat<br/>Small mammal habitat</p> | <p>Dense native shrub vegetation will be planted in Des Moines Creek floodplain and riparian areas (see Table 4.1-3).<br/>The wetland and riparian vegetation will promote increased export of organic matter to Des Moines Creek compared to the existing turf vegetation.<sup>b</sup><br/>Shrub communities will reduce waterfowl use and improve habitat for small mammals.</p>                                                                                                                       |
| <p><b>Indirect and Cumulative Impacts</b><br/>Filled wetlands near Miller Creek will reduce aquatic habitat value of the stream.</p>                                                                                                                                                                                                                                                                                                                                                                   | <p>Restore forest and shrub communities to Wetland A17.<br/>Restore approximately 125 ft of Water D.<br/>Restore wetland areas after construction is complete.</p> | <p>Nutrient and sediment trapping<br/>Organic matter export<br/>Groundwater exchange<br/>Small mammal habitat</p>     | <p>Restoration of wetlands that will be temporarily filled or disturbed will restore functions that previously existed on these sites. Restoration will include establishing pre-disturbance topography, removing three culverts in Water D, and planting the area with native shrub or forest vegetation.<br/>Integration of these areas with the replacement drainage channel mitigation and the embankment layer will promote restoration of pre-existing hydrologic and water quality functions.</p> |
| <p><b>Indirect and Cumulative Impacts</b><br/>Conversion of residential landuses to vegetated stream buffers will promote nutrient and sediment trapping functions and reduce pollutant loading.<br/>Greater densities of riparian vegetation will increase shade, instream habitat, and organic matter export to Miller Creek.<br/>Riparian buffer vegetation will contribute to bank stabilization, sediment, and nutrient removal. It will also provide small mammal habitat (see Table 4.1-3).</p> | <p>Establish and enhance buffers along Miller Creek.</p>                                                                                                           | <p>Nutrient and sediment trapping<br/>Organic matter export<br/>Small mammal habitat</p>                              | <p>Conversion of residential landuses to vegetated stream buffers will promote nutrient and sediment trapping functions and reduce pollutant loading.<br/>Greater densities of riparian vegetation will increase shade, instream habitat, and organic matter export to Miller Creek.<br/>Riparian buffer vegetation will contribute to bank stabilization, sediment, and nutrient removal. It will also provide small mammal habitat (see Table 4.1-3).</p>                                              |

Table 4.1-2. Summary of compensatory mitigation (on- and off-site) for watershed, wetland, and stream impacts at Seattle-Tacoma International Airport (continued).

| Impact                                                                                                                               | Mitigation Action                                                                                                                                                                                                                                                                         | Target Functions to Replace                                                                | Explanation and Key Attributes that Provide Target Functions <sup>a</sup>                                                                                                                                                                                                                                                                                                                                                                                                                                                                                                                                                                                                                                     |
|--------------------------------------------------------------------------------------------------------------------------------------|-------------------------------------------------------------------------------------------------------------------------------------------------------------------------------------------------------------------------------------------------------------------------------------------|--------------------------------------------------------------------------------------------|---------------------------------------------------------------------------------------------------------------------------------------------------------------------------------------------------------------------------------------------------------------------------------------------------------------------------------------------------------------------------------------------------------------------------------------------------------------------------------------------------------------------------------------------------------------------------------------------------------------------------------------------------------------------------------------------------------------|
| Additional development in the watersheds could result in additional cumulative impacts.                                              | Participate in developing and implementing Miller Creek and Des Moines Creek basin plans.                                                                                                                                                                                                 | Aquatic habitat<br>Stream and/or watershed hydrology                                       | These planning processes will identify effective, long-term solutions to restore additional fish habitat functions to Miller and Des Moines Creeks. Projects are anticipated to focus on restoring watershed hydrology through increased regional stormwater detention facilities and improved fish habitat through habitat restoration projects.                                                                                                                                                                                                                                                                                                                                                             |
| The runway fill or borrow area excavation may eliminate water sources that contribute to remaining wetlands downslope of the runway. | Provide trust fund to watershed restoration projects.<br>Design internal drainage and conveyance channels to promote and retain wetland hydrology and streamflow.<br>Monitor wetlands adjacent to the third runway embankment and borrow areas to ensure wetland hydrology is maintained. | Cumulative impacts to aquatic habitat<br><br>Groundwater exchange<br>Organic matter export | The Port will contribute staffing resources and funds to support these efforts. The Port will work with other cooperating jurisdictions to plan and implement appropriate watershed restoration projects.<br>The Port will establish a trust fund to help promote aquatic habitat and other watershed restoration actions.<br>Subsurface and surface replacement channels will continue to collect and distribute groundwater currently surfacing near 12 <sup>th</sup> Avenue South to Miller Creek and associated wetlands.<br>Surface drainage patterns and conveyance swales will be designed to collect and distribute groundwater seepage and surface runoff to wetlands downslope of the borrow areas. |
| <b>OFF-SITE MITIGATION</b>                                                                                                           |                                                                                                                                                                                                                                                                                           |                                                                                            |                                                                                                                                                                                                                                                                                                                                                                                                                                                                                                                                                                                                                                                                                                               |
| <b>Permanent Impacts</b>                                                                                                             |                                                                                                                                                                                                                                                                                           |                                                                                            |                                                                                                                                                                                                                                                                                                                                                                                                                                                                                                                                                                                                                                                                                                               |
| Approximately 18.37 acres of wetland wildlife (avian) habitat will be lost.                                                          | Replace high quality wetland and avian habitat functions off-site at an overall ratio of 2:1.                                                                                                                                                                                             | Passerine bird habitat<br>Waterfowl habitat<br>Small mammal habitat<br>Flood storage       | A variety of wetland classes and vegetation types on a large protected site will provide high quality habitat for a diverse array of birds and small mammals.<br>Open water habitat (including vegetated aquatic beds) will support waterfowl and other bird species that require small ponds for forage or nesting.                                                                                                                                                                                                                                                                                                                                                                                          |

Table 4.1-2. Summary of compensatory mitigation (on- and off-site) for watershed, wetland, and stream impacts at Seattle-Tacoma International Airport (continued).

| Impact | Mitigation Action | Target Functions to Replace | Explanation and Key Attributes that Provide Target Functions <sup>a</sup>                                                                                                                                                                                                                                                                                                                                                                                                                                                                                                                                                                                                                                                                                                                                                                                                                                                                                                                                                                                                                                                             |
|--------|-------------------|-----------------------------|---------------------------------------------------------------------------------------------------------------------------------------------------------------------------------------------------------------------------------------------------------------------------------------------------------------------------------------------------------------------------------------------------------------------------------------------------------------------------------------------------------------------------------------------------------------------------------------------------------------------------------------------------------------------------------------------------------------------------------------------------------------------------------------------------------------------------------------------------------------------------------------------------------------------------------------------------------------------------------------------------------------------------------------------------------------------------------------------------------------------------------------|
|        |                   |                             | <p>Waterfowl and other marsh birds will use flooded persistent and non-persistent emergent plant communities for forage and nesting. These communities will produce organic matter and aquatic insects that provide forage in open water areas.</p> <p>Shrub wetland will fringe marsh communities and provide nesting and forage habitat for songbirds as well as export organic matter to emergent areas.</p> <p>Multi-storied forest communities will provide habitat to songbirds, raptors, and small mammals.</p> <p>A densely vegetated 100-ft-wide buffer will provide additional upland habitats and protect interior upland and wetland habitats from potential disturbances if off-site areas are developed.</p> <p>Microhabitat features-including LWD, vegetated hummocks, interspersions of vegetation types, and proximity to the Green River riparian corridor-will further enhance the area for wildlife.</p> <p>Excavation of portions of the site below an elevation of 45 ft and connection to the floodplain of the Green River by enhancing existing drainage channels will provide flood-storage functions.</p> |

<sup>a</sup> Analyses of the ecological functions provided at each wetland mitigation site are found in Tables 4-13 to 4-16 in the *Wetland Functional Assessment and Impact Analysis* (Parametrix 2001b). All mitigation areas (including, but not limited to, streams, wetlands, buffers, and floodplains) located within 10,000 ft of a runway shall be subject to the provisions of the Port's *Wildlife Hazard Management Plan* (USDA 2000) for the management of wildlife and wildlife attractant areas. On-site mitigation may provide replacement habitat functions for birds, but credit is not sought for this function, as management of birds pursuant to the WHMP may restrict this function.

<sup>b</sup> These enhancements will be coordinated with the Des Moines Creek Basin Committee's proposed RDF.

**Table 4.1-3. Summary of wetland mitigation credit for Seattle-Tacoma International Airport Master Plan Update improvements. (All impacts and mitigation occur in WRIA 9.)**

| Mitigation                                                                                  | Mitigation Area (ac)                        | Mitigation Credit |
|---------------------------------------------------------------------------------------------|---------------------------------------------|-------------------|
| <b>ON-SITE</b>                                                                              |                                             |                   |
| <b>Wetland Restoration – Credit ratio 1:1</b>                                               |                                             |                   |
| Remove Fill Adjacent to Lora Lake                                                           | 1.00                                        | 1.00              |
| Remove Fill at Des Moines Way Nursery Site                                                  | 2.00                                        | 2.00              |
| Remove Fill at Wetland A17                                                                  | 0.30                                        | 0.30              |
| Vacca Farm (prior converted cropland and other upland)                                      | 6.60                                        | 6.60              |
| Temporary Impacts                                                                           | <u>2.05</u>                                 | <u>2.05</u>       |
|                                                                                             | <b>Subtotal 11.95</b>                       | <b>11.95</b>      |
| <b>Wetland Enhancement – Credit ratio 1:2</b>                                               |                                             |                   |
| Des Moines Way Nursery                                                                      | 0.86                                        | 0.43              |
| Vacca Farm (Farmed Wetland, Other Wetlands, Lora Lake)                                      | 5.70                                        | 2.85              |
| Wetlands in Miller Creek Wetland and Riparian Buffer                                        | 10.25                                       | 5.12              |
| Tyee Valley Golf Course                                                                     | 4.50                                        | 2.25              |
| Wetland in Des Moines Creek Buffer                                                          | <u>1.01</u>                                 | <u>0.51</u>       |
|                                                                                             | <b>Subtotal 22.32</b>                       | <b>11.16</b>      |
| <b>Buffer Enhancement- Credit ratio 1:5</b>                                                 |                                             |                   |
| Miller Creek Buffer, South of Vacca Farm                                                    | 40.86                                       | 8.17              |
| Vacca Farm                                                                                  | 4.58                                        | 0.92              |
| Lora Lake                                                                                   | 1.81                                        | 0.36              |
| Tyee Valley Golf Course Mitigation Area Buffer                                              | 1.57                                        | 0.31              |
| West Branch Des Moines Creek Buffer                                                         | 3.38                                        | 0.68              |
| Des Moines Way Nursery                                                                      | <u>2.73</u>                                 | <u>0.55</u>       |
|                                                                                             | <b>Subtotal 54.93</b>                       | <b>10.99</b>      |
| <b>Preservation – Credit Ratio 1:10</b>                                                     |                                             |                   |
| Borrow Area 3 Wetland                                                                       | 2.35                                        | 0.24              |
| Borrow Area 3 Buffer                                                                        | <u>21.20</u>                                | <u>2.10</u>       |
|                                                                                             | <b>Subtotal 23.55</b>                       | <b>2.34</b>       |
|                                                                                             | <b>Total On-Site <sup>a, b</sup> 112.75</b> | <b>36.44</b>      |
| <b>OFF-SITE</b>                                                                             |                                             |                   |
| <b>Wetland Creation<sup>c</sup> - Credit ratio 1:1</b>                                      |                                             |                   |
| Forest (17.20 acres), shrub (6.0 acres), emergent (6.20 acres), and open water (0.60 acres) | 29.98                                       | 29.98             |
| <b>Wetland Enhancement – Credit ratio 1:2</b>                                               |                                             |                   |
|                                                                                             | 19.50                                       | 9.75              |
| <b>Buffer Enhancement – Credit ratio 1:5</b>                                                |                                             |                   |
|                                                                                             | <u>15.90</u>                                | <u>3.18</u>       |
|                                                                                             | <b>Total Off-Site 65.38</b>                 | <b>42.91</b>      |
| <b>TOTAL</b>                                                                                | <b>178.13</b>                               | <b>79.35</b>      |

<sup>a</sup> Mitigation credit has not been assigned for relocating a portion of Miller Creek channel, instream enhancement projects, drainage channel replacement, or a \$300,000 trust fund for watershed restoration.

<sup>b</sup> In- basin mitigation area divided by wetland impacts (18.37 acres permanent plus 2.05 acres temporary) provides a 5.5:1 aerial replacement ratio.

<sup>c</sup> Based on maps of hydric soils, mitigation can be also characterized as restoration.

**Table 4.1-4 Wetland acreage impacts and mitigation by wetland function.**

| Function                      | Impact <sup>b</sup> | On-Site <sup>a</sup> |        | Auburn |        | Comment                                                                                                                                                                                                                                                                                                                                              |
|-------------------------------|---------------------|----------------------|--------|--------|--------|------------------------------------------------------------------------------------------------------------------------------------------------------------------------------------------------------------------------------------------------------------------------------------------------------------------------------------------------------|
|                               |                     | Acres                | Credit | Acres  | Credit |                                                                                                                                                                                                                                                                                                                                                      |
| Resident/<br>Anadromous Fish  | 8.6                 | 74.60                | 30.42  | -      | -      | On-site mitigation includes mitigation for direct impacts to Miller Creek and indirect impacts that may occur through alteration of riparian and hydrologically connected wetlands. For the Miller Creek enhancement areas, buffer averaging areas greater than 100-feet from Miller Creek were excluded from providing this function.               |
| Passerine Birds               | 14.9                | -                    | -      | 65.38  | 42.91  | On-site mitigation credit is not sought for this function due to potential wildlife management actions.                                                                                                                                                                                                                                              |
| Waterfowl                     | 1.9                 | -                    | -      | 6.80   | 6.80   | On-site mitigation credit is not sought for this function due to potential wildlife management actions.                                                                                                                                                                                                                                              |
| Amphibians                    | 9.8                 | 87.05                | 31.95  | 65.38  | 42.91  | The Lora Lake shoreline restoration, restoration at the nursery site, removing human uses, and establishing native plant communities provided by the on-site mitigation will provide habitat for several species.                                                                                                                                    |
| Small Mammals                 | 13.2                | 87.05                | 31.95  | 65.38  | 42.91  | Wetland restoration and enhancement, eliminating human uses, and establishing native plant communities provided by the on-site mitigation will provide habitat for several species.                                                                                                                                                                  |
| Exports Organic<br>Matter     | 10.9                | 87.05                | 31.95  | -      | -      | On-site mitigation includes increasing production and quality of organic matter in wetlands and riparian areas through restoration and enhancement. Maintenance actions that remove organic matter from wetlands, streams, and buffers will also be removed.                                                                                         |
| Ground Water<br>Exchange      | -                   | -                    | -      | -      | -      | Impacts to this function, provided by slope and riparian wetlands (13.6 acres), are avoided by project design and by low flow augmentation.                                                                                                                                                                                                          |
| Flood Storage                 | 4.6                 | 4.6                  | 4.6    | 25     | 25     | This function is mitigated on-site by new flood storage at Vacca Farm and by stormwater detention facilities that are designed to maintain or decrease peak stream flows during flood events.                                                                                                                                                        |
| Nutrient/Sediment<br>Trapping | 16.3                | 87.05                | 31.95  | 65.38  | 42.91  | In basin mitigation for this function is provided by wetland restoration and enhancement and by the changes in land use that convert pollution generating land uses in mitigation areas to native vegetation. The retrofitting of existing pollution generating surfaces with BMPs for water quality treatment also improve water quality of runoff. |

<sup>a</sup> Preservation of wetland and buffer near Borrow Area 3 is excluded from this table.

<sup>b</sup> Functional ratings for Wetlands that exceed low are included in these values.



However, all mitigation areas (including but not limited to wetlands, streams, buffers, and floodplains) and other lands located within 10,000 ft of a runway are subject to the provisions of the Port's WHMP (USDA 2000) for management of wildlife and wildlife attractants (FAA Advisory Circular 150/5200-33). No open-water habitat is to be created within 10,000 ft of the airfield as part of this mitigation plan. As explained in this plan, on-site mitigation is planned to reduce certain existing wildlife hazards to comply with FAA mandates regarding wildlife attractants near airports. Thus, on-site mitigation focuses on providing aquatic habitat enhancements for fish, amphibians, and invertebrates when such can be accomplished without increasing waterfowl use. On-site mitigation also replaces flood storage functions impacted and enhances the biological and physical functions of riparian areas near Miller and Des Moines Creeks. These areas will provide small mammal and song bird habitat, though this is not their primary purpose.

Mitigation for wildlife habitat (bird and small mammals) is provided off-site. The off-site mitigation is designed to provide a large, high-quality, diverse wetland system and is located in the City of Auburn. At this site, habitat mitigation can be provided that is consistent with the FAA Record of Decision (1997c) and Advisory Circular 150/5200-33 and RGL 01-1 (ACOE 2001) regarding wildlife attractants and mitigation near airports.

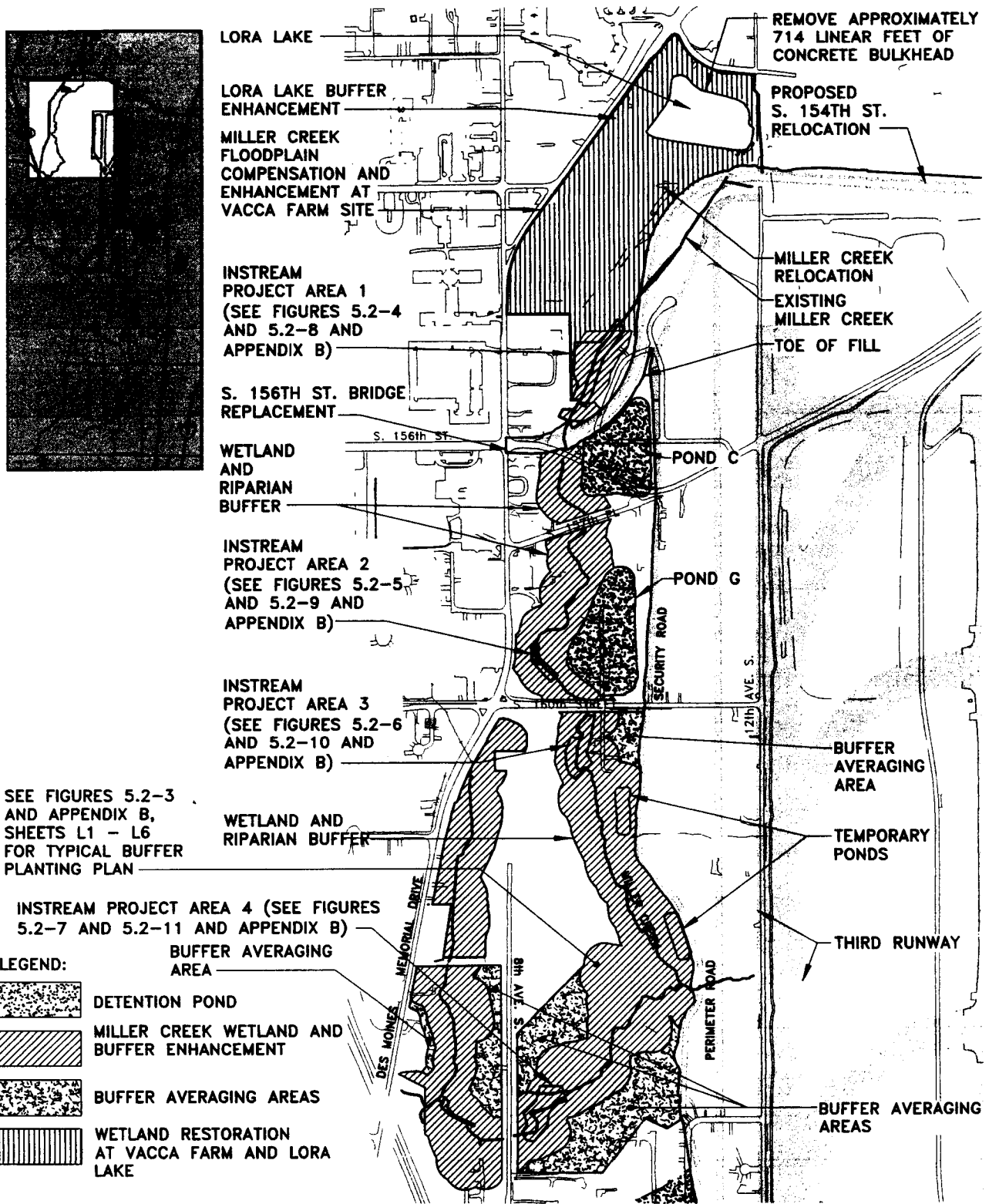
#### **4.1.1 On-Site Mitigation**

Following the recommended preference for on-site mitigation, a number of on-site mitigation elements are proposed to compensate for Master Plan Update improvements affecting wetlands, hydrology, water quality, and aquatic habitat in the Miller and Des Moines Creek basins. Mitigation projects in Miller and Des Moines Creek basins are designed to replace all lost wetland functions with the exception of avian habitat. On-site mitigation is also directed toward removing certain existing land use conditions that, over time, have contributed to degraded wetland and aquatic habitats in these basins. The mitigation projects designed for the Master Plan Update improvements (see Table 4.1-2 and Figure 4.1-3) have been developed in direct response to agency guidelines for on-site functional mitigation.

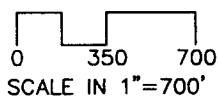
##### **4.1.1.1 Miller Creek Basin**

The focus of mitigation in the Miller Creek basin is to restore and enhance ecosystem functions to the aquatic/wetland systems along a significant portion of Miller Creek. Mitigation actions in the Miller Creek basin will restore wetland, stream, and riparian functions to a 1.5-mile reach, or approximately one third of the entire length of Miller Creek.

The Miller Creek watershed has been modified and habitats degraded by historical and on going agricultural, residential, commercial, and industrial development. Approximately 80 percent of the watershed has been converted from its original forested condition to residential or commercial land



FILE: 291203\_F4  
DATE: 11/09/01



**Figure 4.1-3  
Locations of Mitigation  
Projects in the  
Miller Creek Basin**

uses (Parametrix 2000a, 2001a). Increased impervious surfaces have resulted in increased runoff rates and volumes, which have contributed to erosion and down cutting in high-energy reaches and increased sedimentation and habitat degradation in low-gradient reaches (FAA 1996; KCSWM 1994). Runoff from residential, commercial, and agricultural areas has increased input of sediment, nutrients, and pollutants to the stream. Upland and wetland riparian areas adjacent to the stream have been altered from the original forest and/or shrub cover to impervious surfaces, agricultural fields, residential lawns, or ornamental landscaping. Native plant and animal habitats have been reduced in size and fragmented, resulting in a loss of species diversity.

The natural channel morphology of Miller Creek has been altered, particularly in reaches above South 160<sup>th</sup> Street. Extensive areas of the channel have been armored with riprap or retaining walls, and dredged or straightened to protect property adjacent to the stream or to drain land for agricultural uses. For much of its length, Miller Creek lacks connections to adjacent floodplains, floodplain wetlands, or riparian areas due to filling of adjacent wetlands, as well as dredging and straightening of the channel to increase conveyance. These changes have resulted in a lack of habitat complexity, a lack of woody debris in the channel, a lack of shading from riparian vegetation, the loss of surface water storage, and degraded water quality and biotic integrity in much of the basin.

To replace functions impacted by the Master Plan Update improvements and to restore and enhance aquatic and wetland functions in the Miller Creek basin, the Port proposes the following specific mitigation:

- Restore natural channel morphology, habitat complexity, and instream habitat along an approximately 1.4-mile reach of Miller Creek extending from south of Lora Lake to Des Moines Memorial Drive.
- Restore floodplain, floodplain wetlands, and riparian areas along the upper reaches of Miller Creek, and re-integrate floodplains and adjacent wetlands with the stream.
- Restore, replace, and enhance wetland and aquatic habitat functions to the currently degraded lacustrine, stream, floodplain, and riparian wetland system along the upper reaches of Miller Creek.
- Maintain wetland hydrology and base flow functions in wetlands adjacent to the embankment fill by providing surface water drainage features to convey groundwater and surface water runoff from the new embankment to downslope wetlands.
- Restore and enhance wetland and aquatic functions, and protect the long-term viability of these systems by establishing native forested buffers around wetlands and aquatic systems from Lora Lake to Des Moines Memorial Drive.
- Restore habitat connectivity in the upper reaches of the Miller Creek basin by providing a continuous forested wetland and riparian corridor connecting currently fragmented wetland, aquatic, and riparian habitats between Lora Lake and Des Moines Memorial Drive.

To accomplish these objectives, mitigation projects will be concentrated in two areas along the upper reaches of Miller Creek: (1) Lora Lake and the Vacca Farm and (2) Miller Creek and its riparian zone between Lora Lake and Des Moines Memorial Drive.

In addition to these projects, the Port will establish watershed trust funds to promote local stream restoration projects in the Miller Creek basin.

#### **4.1.1.2 Des Moines Creek Basin**

Mitigation projects for the Des Moines Creek basin are designed to mitigate unavoidable project impacts to wetlands and aquatic resources by restoring wetland and stream functions, and by providing mitigation for potential indirect effects to wetland hydrology. Mitigation actions in the Des Moines Creek basin will increase infiltration adjacent to the stream, reduce pollutant runoff, increase sediment retention, and improve nutrient cycling functions in the wetland adjacent to Des Moines Creek. To replace functions impacted by Master Plan Update improvements and to restore and enhance aquatic and wetland habitat in the Des Moines basin, the Port proposes the following specific mitigation:

- Restore and enhance wetland and aquatic habitat by replacing the existing turf grass wetland with a native shrub wetland at the Tyee Valley Golf Course, adjacent to Des Moines Creek.
- Enhance water quality and fish habitat, and restore stream conditions in Des Moines Creek by establishing a forested buffer along at least 1,600 linear feet of the west branch of Des Moines Creek.
- Avoid, minimize, and mitigate potential indirect hydrology impacts to wetlands adjacent to the borrow areas by directing groundwater seepage and/or surface water runoff to wetlands near the borrow areas.

In addition to these projects, the Port will establish watershed trust funds to promote local stream restoration projects in the Des Moines Creek basin.

#### **4.1.1.3 On-site Stormwater Mitigation**

The Port will construct the necessary stormwater conveyance, detention, and treatment facilities to manage runoff from both newly developed project areas and existing airport areas. These facilities will not only mitigate new construction impacts, as required by current stormwater regulations and mitigation goals identified during the environmental review process, but they will also help to reduce flood peaks in these basins to further mitigate the impacts of airport stormwater discharges.

On-site stormwater facilities will be constructed in Miller, Walker, and Des Moines Creek basins at 14 separate locations and provide approximately 344 acre-ft of new storage. The following sections describe specific mitigation to reduce stormwater impacts from Master Plan Update improvements. Detailed information on mitigation for stormwater quantity and quality is included in the *Comprehensive Stormwater Management Plan* (Parametrix 2000a, 2001a).

#### **Stormwater Detention Based on Higher Stormwater Standards**

Detention storage provided for Master Plan Update improvement projects will exceed that normally required by local regulations, and result in additional mitigation of stormwater impacts from project areas, including reduced peak stormwater runoff impacts on Miller, Walker, and Des Moines Creeks.

### **Reduce Runoff from Existing Airport Areas With Stormwater Detention**

To control runoff from areas of the airport developed prior to 1994, stormwater detention will be provided to mitigate existing runoff impacts. Proposed detention facilities in Miller, Walker, and Des Moines Creeks include stormwater detention to mitigate impacts of pre-1994 development. In the retrofit analysis, the pre-development flow rates assumed that existing land cover is 10 percent impervious area, 75 percent forest, and 15 percent grass (also known as the pre-development “target flow regime”). Stormwater detention designs for Miller, Walker, and Des Moines Creek basins are based on the Level 2 flow control.

### **Provide Infiltration at Stormwater Detention Facilities**

Further improvements to low stream flows will be achieved by infiltrating stormwater at the detention facilities. Because site conditions must be favorable for infiltration to be feasible, the Port has evaluated infiltration for stormwater detention facility design. Ponds in the Miller Creek Basin will use infiltration where practicable.

### **Water Quality Mitigation**

The STIA Master Plan Update improvement projects are not expected to impact existing water quality because:

- The quality of STIA runway stormwater has been shown to be comparable to or better than regional urban stormwater.
- In contrast to existing land uses, all Master Plan Update improvements will be served by BMPs in compliance with the *Stormwater Management Manual for Western Washington* (Ecology 2001b) (e.g., bioswales, filter strips, wet vaults, infiltration).

Since Miller, Walker, and Des Moines Creeks drain urban watersheds, they have been subject to cumulative impacts of heavy metals, oils, and grease from nearby urban highways; fecal coliform from failing residential septic systems and adjacent farms; and suspended solids and litter carried in urban runoff. They also receive increased levels of phosphorus and nitrogen from fertilization of landscaping or cultivated areas. These impacts are typical of an urban environment supporting an assortment of residential, commercial, and industrial activities. Sources of many of these pollutants will be removed as part of the Master Plan Update improvements within the approximately 258-acre acquisition area. Because actions to mitigate impacts to water quality will be in place, the quality of stormwater runoff in the future will be equal to or better than current stormwater quality. A detailed discussion of water quality benefits and mitigation is included in the *Comprehensive Stormwater Management Plan* (Parametrix 2000a, 2001a).

#### **4.1.2 Off-Site Mitigation**

Off-site mitigation is proposed because FAA regulations generally prohibit the siting of potential wildlife attractants (including wetland mitigation) within 10,000 ft of active runways.<sup>13</sup> The Port

---

<sup>13</sup> For the Master Plan Update, FAA has specified off-site wetland mitigation as a requirement of Federal funding (FAA 1997a).

searched for wetland mitigation sites in the Des Moines and Miller Creek watersheds that could be used to provide replacement wildlife habitat; however, these watersheds are almost totally within the 10,000-ft exclusion area for wildlife habitat mitigation. Areas within these two watersheds that are more than 10,000 ft from existing runways were found not to be suitable for mitigation due to their small size, developed nature, forested condition, or the lack of hydrologic conditions necessary to support wetlands.

To mitigate for the loss of wildlife habitat due to the Master Plan Update improvements, the Port will construct wetland mitigation off-site on a 65-acre parcel in the City of Auburn. This wetland mitigation area will replace lost wetland functions at a minimum 2:1 replacement ratio. This mitigation provides the opportunity to create, restore, and enhance high-quality, diverse forested, shrub, emergent, and open water wetland habitats and functions to a site where these functions are currently absent or degraded. Approximately 17.2 acres of forested wetland, 6.0 acres of shrub wetland, 6.2 acres of emergent wetland, 0.60 acre of open water habitat will be created or restored. On about 19.5 acres of emergent wetland dominated by non-native pasture grasses, native wetland forest communities will be restored. Overall habitat functions will be enhanced by providing approximately 11.9 acres of forested buffers around the perimeter of the site and approximately 4.0 acres of upland habitat within the interior portion of the site. Replacing habitat currently dominated by pasture grasses with native forested, shrub, and emergent wetland plant communities will enhance wetland functions in existing wetlands.

## **4.2 ECOLOGICAL FUNCTIONS PROVIDED BY THE MITIGATION**

The mitigation sites have been designed to replace and enhance the ecological functions provided by wetlands and streams impacted by the MPU projects at STIA. Mitigation also includes the establishment and enhancement of protective buffers where none are present today. The establishment and enhancement of these buffers at the on- and off-site mitigation areas improve the ecological condition above baseline (or pre-project) conditions, as the buffer areas are currently developed or otherwise degraded by various land uses. The specific functions replaced at each of the mitigation sites are discussed below. The value of the buffers in protecting ecological functions of the mitigation sites is also discussed below.

### **4.2.1 Vacca Farm Restoration and Miller Creek Relocation**

Mitigation at this site focuses on replacing the Miller Creek stream channel, replacing riparian habitat functions, replacing lost floodplain functions, improving water quality functions, improving organic matter export functions, and reducing the habitat value of the area to waterfowl and flocking birds. These functional changes will be achieved as described in the following paragraphs:

- **Fish and Aquatic Habitat**

The new stream channel will provide improved fish and other aquatic habitat because it is designed with a number of beneficial features to cutthroat trout and other organisms that are lacking in the present stream (see Appendix K). The primary characteristics provided by the design are LWD, woody riparian vegetation, and substrate variability. Each of these features will enhance fish and aquatic habitat. Increased amounts of woody riparian vegetation will result in increased shade, allochthonous inputs (food sources in the form of coarse particulate organic matter [CPOM] and terrestrial invertebrates), and sources of woody debris. Increased

LWD generally provides habitat complexity, including small plunge pools, fish cover, invertebrate substrates, variable water depths and velocities, etc. These conditions will provide nesting, resting, and forage habitat for fish and other aquatic life. Increased streambed variability in the form of gravel, wood, and CPOM will also increase the diversity of invertebrate habitat. [Note that the role of LWD and riparian conditions on aquatic systems is extensively reviewed in Allen (1995), Bisson and Bilby (1998), Bisson et al. (1987), Gregory et al. (1986), Harmon et al. (1986), Hershey and Lamberti (1998)].

The shallow water along the margin of Lora Lake will be improved aquatic habitat compared to existing conditions. The replacement of fill, lawns and riprap coupled with restored wetlands, and plantings of riparian tree and shrub vegetation will improve aquatic habitat by providing shade and organic matter input (woody debris, leaf matter, and insects) that will support fish and other aquatic life.

- **Amphibian Habitat**

In Puget Sound, amphibian species using non-flooded wetland and riparian areas typically prefer habitats dominated by woody plant communities (Brown 1985; Johnson and O'Neil 2001; Kauffman et al. 2001; Rose et al. 2001). Thus, converting farmland to shrub and forested wetlands and buffers will improve habitat conditions for amphibians. The restored floodplain wetlands will provide habitat for adult amphibians and breeding habitat (logs and forest soils) for species that breed in non-aquatic habitat (e.g., red-backed salamander, ensatina). The mitigation site will also improve amphibian dispersal because of the new South 154<sup>th</sup> Street bridge that will span the floodplain of Miller Creek, and removal of the existing bridge, which prevents movement of amphibians through riparian areas. The mitigation will also improve connections to upstream, forested wetlands (Wetlands 1 through 9).

The removal of riprap and fill from the margin of Lora Lake will and provide breeding habitat for amphibians that require surface water for breeding. Removing fill and restoring shrub wetlands along the lake margin will provide non-aquatic habitat for amphibians.

- **Small Mammal Habitat**

Planting of vegetation in riparian areas and restoring wetlands will improve habitat for small mammals by creating a diversity of forage and cover habitat for them. Logs and woody vegetation added to the site will provide denning and forage areas (Brown 1985; Johnson and O'Neil 2001; Kauffman et al. 2001; Rose et al. 2001). The new South 154<sup>th</sup> Street bridge and demolition of the existing bridge will improve habitat connectivity for small mammals, because the new bridge will span the floodplain and allow unimpeded passage of small mammals. The restoration also improves habitat connectivity to Wetlands 1 through 9 that are located north and east of the site.

Removal of fill and restoration of shrub wetlands along the margin of Lora Lake will provide small mammal habitat for wetland and non-wetland dependent species.

- **Nutrient Retention and Sediment Trapping (Water Quality)**

The new channel is designed to have overbank flow during the 1-year and higher storm events. Smaller storms will flood portions of the floodplain through backwater flooding. In each case, floodwater flows into shrub and forested riparian areas will promote sediment trapping and

retention of nutrients in the restored wetland (see Mitsch and Gosselink 2000 and Belt et al. 1992). In the riparian wetlands, planting woody vegetation will allow this function to occur at higher levels than currently exists on the farmland or lawn areas (adjacent to Lora Lake). The replacement of herbaceous vegetation with woody plant communities would promote storage of nutrients in organic matter (wood) which decomposes slower than herbaceous vegetation (Harmon et al. 1986). Removal of farming and residential land use activities will remove activities that degrade water quality (Horner et al. 1994; Los Angeles County Department of Public Works 2000; Steur et al. 1997; Bannerman et al. 1999; Minnesota Pollution Control Agency 2000).

- **Organic Matter Export**

The new channel is designed to have overbank flow during the 1-year and higher storm events. Smaller storms will flood portions of the floodplain through backwater flooding. As floodwaters recede, export of dissolved and particulate organic matter from the floodplain to the stream is likely, and will occur at higher levels because greater amounts and types of organic matter (leaves, twigs, branches, etc.) will be on site and available for export.

Replacing of grass-dominated riparian plants adjacent to the stream and Lora Lake with native woody riparian vegetation will increase the amount and diversity of organic matter (i.e., readily decomposable leaves and woody debris that is slower to decompose) available to the stream and aquatic habitat of Lora Lake.

The high productivity expected in forest and shrub wetlands will result in accumulations of organic matter in the saturated soil of the restored wetland. Groundwater movement through the site and flooding will transport dissolved organic matter to Miller Creek (Fieberg et al. 1990; Emmet et al. 1994; Dosskey and Bertsch 1994). Placement of logs in Miller Creek and development of a natural riparian zone will help trap organic debris in the stream channel (Bisson and Bilby 1998; Speaker et al. 1988; Bisson et al. 1987), where it will be available for processing by aquatic invertebrates, thus benefiting the food chain.

Removal of plowing and soil drainage systems will reduce the potential loss of peat soils through oxidation, which occurs in better-drained soils (Ford 1993). Restoring natural hydrology and natural plant communities will provide a carbon cycle where greater amounts of organic matter decomposes anaerobically with subsequent export from the site as dissolved organic carbon, and accumulation on-site as organic soil.

- **Groundwater Exchange**

The mitigation area is predominantly a groundwater discharge area (as indicated the historical presence of peat soils (Rigg 1958; Paulson 1953). Enhancement activities will not alter this hydrology pattern. Restoration as wetland, including removal of some agricultural drainage systems, would reduce the velocity of some groundwater that moves across the site.

- **Flood Storage**

The Vacca Farm mitigation site is designed to replace floodplain filled by the project (8,500 cubic yards) and provide a small net increase (9,600 cubic yards). The overall significance of the wetlands and farmland in providing this function will not change.



- **Waterfowl Habitat**

As directed by FAA, waterfowl habitat functions are not proposed at this mitigation area. The current farmland will be planted with trees and shrubs to provide a complete canopy cover that will prevent ground foraging by waterfowl. Additionally, while portions of the site will flood during 1-year and greater storm events, the presence of standing water on the site will be for a short duration and obscured by vegetation. Thus, it will not attract wildlife.

The pond margin along Lora Lake will be modified to reduce use by waterfowl. Replacing lawns with riparian tree and shrub vegetation will eliminate forage and resting areas used by waterfowl.

- **Passerine Bird Habitat**

Planting tall shrubs and trees on the site will reduce foraging by flocking birds. The plant species to be planted do not provide direct food sources (i.e., fruits, nuts, seeds, berries, etc.) for avifauna. The vegetation will produce insects that a variety of passerine birds will forage upon. The combination of these elements will limit bird use, and shift use from flocking birds to forest species. Planting trees and shrubs around Lora Lake could increase forage opportunity for some birds such as kingfisher.

#### **4.2.2 Miller Creek Buffer Wetland Enhancement**

Enhancing the riparian zone along Miller Creek, including the enhancement of instream habitat, buffers, will provide the following functions:

- **Fish and Aquatic Habitat**

The instream enhancements will improve habitat for fish and other aquatic organisms because of the new beneficial features that will be added to the stream that are currently lacking. The primary features provided are LWD, woody riparian vegetation, substrate variability, and removal of riprap. Each of these features will enhance fish and aquatic habitat (see Cederholm et al. 1997). Increased amounts of woody riparian vegetation will result in increased shade, allochthonous inputs (food sources in the form of CPOM and terrestrial invertebrates), and sources of woody debris. Increased LWD generally provides habitat complexity, including small plunge pools, fish cover, invertebrate substrates, variable water depths and velocities, etc. These conditions provide nesting, resting, and forage habitat for fish and other aquatic life. Increased streambed variability in the form of gravel, wood, and CPOM will also increase the diversity of invertebrate habitat. Removal of riprap will provide more natural channel banks that improve invertebrate habitat and forage areas for fish. Buffer enhancement will increase the types and amounts (terrestrial insects, plant detritus, etc.) of organic matter inputs to the stream, thus increasing forage resources for fish and invertebrates. The role of riparian conditions and LWD on aquatic systems is extensively reviewed in Allen (1995), Bisson and Bilby (1998), Bisson et al. (1987), Gregory et al. (1986), Harmon et al. (1986), Hershey and Lamberti (1998), Harmon et al. (1986), and Lassetre (1999).

- **Amphibian Habitat**

The wetland and buffer enhancements that replace lawns and homes will improve conditions for amphibians by enhancing vegetated habitat in riparian wetlands. This enhancement will provide improved habitat for adult terrestrial amphibians. Improved habitat for terrestrial breeding amphibians (e.g., red-backed salamander, ensatina) will be provided by increased amounts of forest vegetation and woody debris in the Miller Creek buffer and riparian wetlands (Brown 1985; Johnson and O'Neil 2001; Kauffman et al. 2001; Rose et al. 2001). The mitigation site will also improve amphibian dispersal because of improved connections to habitat at Vacca Farm, Lora Lake, and other riparian wetlands.

- **Organic Matter Export**

Replacing grass-dominated riparian areas with native woody riparian vegetation will increase the export of organic matter to the creek. In many places, lawn vegetation will be replaced with tree and shrub vegetation. The higher productivity and greater structural diversity expected in the riparian wetlands will increase the amount and diversity of organic matter (i.e., insects, leaves, branches, trees, etc.) reaching the stream. Accumulations of organic matter in the saturated soil and increased export to the stream as detritus and woody debris or as dissolved carbon are likely to occur. Where riparian vegetation consists of blackberry, its replacement with a multi-storied forest and shrub canopy will also increase the type and diversity of organic matter reaching the stream.

Placing LWD in the stream channel and removing residential land uses, as part of mitigation, will result in restoration of natural patterns of organic matter storage and cycling in the stream channel (Bisson et al. 1987; Harmon et al. 1986). For example, under residential land use, many residents clear the riparian buffer of trees or shrubs, reducing delivery of organic matter to the stream channel. When trees or branches do fall into the creek, they are typically removed by the landowner. Removing these logs and branches prevents trapping of organic matter in the channel, and promotes its conveyance downstream. Placement of logs in the stream as mitigation will promote trapping and storage of organic matter in the mitigation site, where its ultimate decomposition will benefit aquatic organisms.

Groundwater movement through the riparian wetlands will transport dissolved organic matter (Ford 1993) to Miller Creek. Removing artificial bank armoring and placing in-channel woody debris will improve overbank flow in some sections. This overbank flow, coupled with overhanging riparian vegetation, will provide additional sources of organic matter export into the stream channel. Where riparian wetland vegetation is currently pasture or blackberry, planting tree and shrub communities will increase the amount and diversity of organic matter available to the stream and wetlands.

- **Nutrient Retention and Sediment Trapping (Water Quality)**

Water quality functions of the buffer and riparian wetlands will improve for several reasons. Many impacts to wetlands and the stream will be removed as a result of the project and mitigation. For example, several dozen houses and buildings, lawns, driveways, etc. will be removed from the mitigation area, thus removing features and land uses that contribute to the

degradation of water quality (Horner et al. 1994; Los Angeles County Department of Public Works; 2000; Steur et al. 1997; Bannerman et al. 1999; Minnesota Pollution Control Agency 2000). Several septic systems will be removed from the mitigation area, as will one or more horse pasture, which also contribute to degradation of water quality. Outside of the mitigation area, removing streets and residential land use will reduce the amount of pollutant loading to the wetland and stream system. Restoration of these disturbed areas will increase their capacity to provide water quality functions by establishing natural nutrient cycling pathways.

- **Groundwater Exchange**

The mitigation area is a predominantly groundwater discharge area and enhancement activities will not alter this hydrology pattern (Hart Crowser 2000c; Pacific Ground Water Group 2000, 2001). Design of the embankment and the hydrologic function of the embankment will protect this function.

- **Small Mammal Habitat**

Planting riparian vegetation in riparian areas and restoring wetlands will improve habitat for small mammals by creating a diversity of forage and cover habitat for them. Increased woody vegetation and debris will provide denning and forage areas (Brown 1985; Johnson and O'Neil; 2001; Kaufman et al. 2001; Rose et al. 2001). The new 154<sup>th</sup> Street bridge and demolition of the existing bridge will improve habitat connectivity for small mammals using the Miller Creek buffer.

- **Passerine Bird Habitat**

The buffer plants will provide limited direct food sources (i.e., fruits, nuts, seeds, berries, etc.) for avifauna, but will produce insects that a variety of passerine birds forage upon. While not a specific goal of the mitigation, the increased amounts of woody and forest vegetation will provide additional and improved habitat for forest-dwelling bird species.

Buffering Miller Creek and associated riparian wetlands with 100-ft average buffers will improve the function of the stream compared to baseline. For most functions of concern, the buffers will ameliorate temperature control and provide/protect instream habitat. The 100-ft buffer width, in some locations,<sup>14</sup> is somewhat less than the width that would maximize recruitment of large woody debris (Table 4.2-1). At this width, some reduction in delivery of woody debris to the stream compared to a mature forested buffer in an undisturbed area will occur.<sup>15</sup> Delivery of wood above the current baseline will be substantial because much of the buffer is currently landscaped and homeowners remove woody debris.

---

<sup>14</sup> In many locations, the combination of forested riparian wetlands, buffer-averaging areas, and 100-ft stream buffers exceed widths recommended for this function. Where buffers are less than recommended distances, hazard trees can be cut to fall into the buffer to supplement delivery of wood to buffers and creeks.

<sup>15</sup> In many areas, trees are absent from areas farther than 100 ft from the stream (the buffer averaging approach has incorporated several forested areas beyond the 100-ft buffer into the mitigation). Since these areas currently lack trees, the reduction of this function will occur in future years, when planted trees have grown to heights greater than 100 ft. This could occur after 50 to 75 years.

**Table 4.2-1. Riparian habitat buffer widths needed to protect riparian habitat functions (modified from Knutsen and Naef [1997]).**

| Riparian Habitat Function           | Buffer (Ft) | Literature Sources                                       | Evaluation for Master Plan Update Mitigation                                                                                                                                                                                                                                                                                                                                                                                                                                                                                                                      |
|-------------------------------------|-------------|----------------------------------------------------------|-------------------------------------------------------------------------------------------------------------------------------------------------------------------------------------------------------------------------------------------------------------------------------------------------------------------------------------------------------------------------------------------------------------------------------------------------------------------------------------------------------------------------------------------------------------------|
| <b>Water Temperature Control</b>    |             |                                                          |                                                                                                                                                                                                                                                                                                                                                                                                                                                                                                                                                                   |
| 60-80% shading                      | 35 to 125   | Brazier et al. 1973                                      | The 100 ft vegetated buffer would provide full shade of the narrow stream channels and thus provide water temperature control function. In limited areas where the buffer is reduced to 50 ft, full shading is also expected to occur because of the dense multi-layered planting approach.<br><br>Since several buffer areas are currently disturbed, shading will increase over time, and is not currently optimal in all locations.                                                                                                                            |
|                                     | 35 to 120   | Johnson and Ryba 1992                                    |                                                                                                                                                                                                                                                                                                                                                                                                                                                                                                                                                                   |
|                                     | 39          | Corbett and Lynch 1985                                   |                                                                                                                                                                                                                                                                                                                                                                                                                                                                                                                                                                   |
|                                     | 49 to 100   | Hewlett and Fortson 1982                                 |                                                                                                                                                                                                                                                                                                                                                                                                                                                                                                                                                                   |
|                                     | 59          | Moring 1975                                              |                                                                                                                                                                                                                                                                                                                                                                                                                                                                                                                                                                   |
| 50-100% shading                     | 60 to 125   | U.S. Forest Service et al. 1993                          |                                                                                                                                                                                                                                                                                                                                                                                                                                                                                                                                                                   |
|                                     | 100         | Lynch et al. 1985                                        |                                                                                                                                                                                                                                                                                                                                                                                                                                                                                                                                                                   |
|                                     | 100         | Beschta et al. 1987                                      |                                                                                                                                                                                                                                                                                                                                                                                                                                                                                                                                                                   |
|                                     | 100         | Johnson and Ryba 1992                                    |                                                                                                                                                                                                                                                                                                                                                                                                                                                                                                                                                                   |
|                                     | 100 to 141  | Jones et al. 1988                                        |                                                                                                                                                                                                                                                                                                                                                                                                                                                                                                                                                                   |
| 80% shading                         | 151         | Steinblums et al. 1984                                   |                                                                                                                                                                                                                                                                                                                                                                                                                                                                                                                                                                   |
| <b>Large Woody Debris</b>           |             |                                                          |                                                                                                                                                                                                                                                                                                                                                                                                                                                                                                                                                                   |
|                                     | 100         | Murphy and Koski 1989                                    | The mitigation places a substantial amount of LWD in the stream at construction. The stream buffer mitigation will substantially improve recruitment of LWD over existing conditions. When trees in the buffer reach mature heights in 60 to 120 years, recruitment will be somewhat reduced (5 to 15%) from levels expected if buffers were 150 ft. Recruitment could be increased to natural levels (and accelerated over time) by placing any trees that have fallen outside the buffer within the buffer and by felling hazard trees inward toward the creek. |
|                                     | 103         | Bottom et al. 1983                                       |                                                                                                                                                                                                                                                                                                                                                                                                                                                                                                                                                                   |
|                                     | 148         | Harmon et al. 1986                                       |                                                                                                                                                                                                                                                                                                                                                                                                                                                                                                                                                                   |
|                                     | 150         | McDade et al. 1990                                       |                                                                                                                                                                                                                                                                                                                                                                                                                                                                                                                                                                   |
|                                     | 150         | Robison and Beschta 1990                                 |                                                                                                                                                                                                                                                                                                                                                                                                                                                                                                                                                                   |
|                                     | 165         | Van Sickle and Gregory 1990                              |                                                                                                                                                                                                                                                                                                                                                                                                                                                                                                                                                                   |
|                                     | 180         | Thomas et al. 1993                                       |                                                                                                                                                                                                                                                                                                                                                                                                                                                                                                                                                                   |
| <b>Filter Sediments</b>             |             |                                                          |                                                                                                                                                                                                                                                                                                                                                                                                                                                                                                                                                                   |
| 75% sediment removal                | 100 to 125  | Karr and Schlosser 1977                                  | This function will occur as a result of the 100-ft average stream buffers. Where buffers are reduced to a minimum of 50 ft, the function will also be realized because there will be no areas of bare ground or erosion near the creeks.                                                                                                                                                                                                                                                                                                                          |
| 90% of sediment removal at 2% grade | 100         | Johnson and Ryba 1992                                    |                                                                                                                                                                                                                                                                                                                                                                                                                                                                                                                                                                   |
| Sediment removal                    | 100         | Erman et al. 1977; Moring et al. 1982; Lynch et al. 1985 | Permanent and temporary stormwater management facilities and other BMPs (which collect sediment from impervious and construction surfaces) provide this buffer function.                                                                                                                                                                                                                                                                                                                                                                                          |
|                                     | 200         | Terrell and Perfetti 1989                                |                                                                                                                                                                                                                                                                                                                                                                                                                                                                                                                                                                   |

**Table 4.2-1. Riparian habitat buffer widths needed to protect riparian habitat functions (modified from Knutson and Naef [1997]) (continued).**

| <b>Riparian Habitat Function</b>                                      | <b>Buffer (Ft)</b> | <b>Literature Sources</b> | <b>Evaluation for Master Plan Update Mitigation</b>                                                                                                                                                                                                                                                                                                         |
|-----------------------------------------------------------------------|--------------------|---------------------------|-------------------------------------------------------------------------------------------------------------------------------------------------------------------------------------------------------------------------------------------------------------------------------------------------------------------------------------------------------------|
| 50% deposition                                                        | 289                | Gilliam and Skaggs 1988   |                                                                                                                                                                                                                                                                                                                                                             |
| Effective control of non-channelized sediment flow                    | 200 to 300         | Belt et al. 1992          | Larger buffers to remove sediment are recommended for land use conditions that are not relevant to the Master Plan Update mitigation sites, such as agricultural, forestland, mining, or other land uses. Studies that identify buffer needs in excess of 100 ft have not considered TESC and extensive stormwater management facilities to control runoff. |
| <b>Filter Pollutants</b>                                              |                    |                           |                                                                                                                                                                                                                                                                                                                                                             |
| Nutrient reduction                                                    | 13                 | Doyle et al. 1977         |                                                                                                                                                                                                                                                                                                                                                             |
| Minimum                                                               | 33                 | Petersen et al. 1992      |                                                                                                                                                                                                                                                                                                                                                             |
|                                                                       | 49                 | Castelle et al. 1992      |                                                                                                                                                                                                                                                                                                                                                             |
|                                                                       | 52                 | Jacobs and Gilliam 1985   |                                                                                                                                                                                                                                                                                                                                                             |
| Nutrient removal using the multi-species riparian buffer strip system | 66                 | Schultz et al. 1995       | The stream buffers are large enough to provide this function. They are generally not intended to do so because BMPs and the IWS route pollutants from pollution-generating surfaces through the stormwater management system for treatment. High levels of nutrient and chemical loading associated with agricultural land uses will not occur.             |
| Remove fecal coliforms                                                | 100 to 141         | Jones et al. 1988         | The larger buffers recommended for removal of nutrients, fecal coliform, and pesticides from agricultural land uses are not relevant to the Master Plan Update mitigation sites.                                                                                                                                                                            |
|                                                                       | 100                | Grismer 1981              |                                                                                                                                                                                                                                                                                                                                                             |
|                                                                       | 100                | Lynch et al. 1985         |                                                                                                                                                                                                                                                                                                                                                             |
| Nitrates removed to meet drinking water standards                     | 100                | Johnson and Ryba 1992     |                                                                                                                                                                                                                                                                                                                                                             |
| Nutrient pollution in forested riparian areas                         | 100                | Terrell and Perfetti 1989 |                                                                                                                                                                                                                                                                                                                                                             |
| Nutrient removal                                                      | 118                | Young et al. 1980         |                                                                                                                                                                                                                                                                                                                                                             |
| Pesticides and animal waste                                           | 200                | Terrell and Perfetti 1989 |                                                                                                                                                                                                                                                                                                                                                             |
| Nutrient pollution in herbaceous or cropland riparian areas           | 600                | Terrell and Perfetti 1989 |                                                                                                                                                                                                                                                                                                                                                             |

**Table 4.2-1. Riparian habitat buffer widths needed to protect riparian habitat functions (modified from Knutson and Naef [1997]) (continued).**

| <b>Riparian Habitat Function</b>  | <b>Buffer (Ft)</b> | <b>Literature Sources</b>                                | <b>Evaluation for Master Plan Update Mitigation</b>                                                                                                                                                                                                                                                                                                             |
|-----------------------------------|--------------------|----------------------------------------------------------|-----------------------------------------------------------------------------------------------------------------------------------------------------------------------------------------------------------------------------------------------------------------------------------------------------------------------------------------------------------------|
| <b>Erosion Control</b>            |                    |                                                          |                                                                                                                                                                                                                                                                                                                                                                 |
| Bank erosion control              | 100                | Raleigh et al. 1986                                      | Full erosion control potential of the buffer will be realized. There are no high mass wasting areas present in the stream buffer. Specific mitigation is planned to improve bank stability and natural channel morphology.                                                                                                                                      |
| High mass wasting area            | 125                | Cederholm 1994                                           |                                                                                                                                                                                                                                                                                                                                                                 |
| <b>Microclimate Influence</b>     |                    |                                                          |                                                                                                                                                                                                                                                                                                                                                                 |
| In forested ecosystem             | 200 to 399         | Chen et al. 1990                                         | These recommendations are made for old-growth forest ecosystems and are not relevant to urban conditions found in the Master Plan Update mitigation sites.                                                                                                                                                                                                      |
|                                   | 525                | Harris 1984, Franklin and Forman 1987                    | This function is lost from urban areas as there is no longer a forested ecosystem. However, the stream buffer mitigation will increase the microclimate influence of the buffer above existing baseline. It is unlikely any negative impact to aquatic or terrestrial organisms will result.                                                                    |
| <b>Aquatic Habitat</b>            |                    |                                                          |                                                                                                                                                                                                                                                                                                                                                                 |
| Aquatic insects                   | 100                | Erman et al. 1977                                        | This function will be fully realized where 100-ft buffers are present. In limited areas, the function may be sub-optimal due to 50-ft buffers. However, aquatic habitat conditions at the mitigation sites will improve above baseline due to the instream and buffer enhancement projects, and buffer averaging is included to mitigate reduced buffer widths. |
| Benthic invertebrates food supply | 100                | Erman et al. 1977                                        |                                                                                                                                                                                                                                                                                                                                                                 |
| Macroinvertebrate density         | 100                | Newbold et al. 1980                                      |                                                                                                                                                                                                                                                                                                                                                                 |
|                                   | 100                | Gregory et al. 1987                                      |                                                                                                                                                                                                                                                                                                                                                                 |
| Riparian invertebrates            | 100                | Erman et al. 1977; Roby et al. 1977; Newbold et al. 1980 |                                                                                                                                                                                                                                                                                                                                                                 |
| Brook trout                       | 100                | Raleigh 1982                                             |                                                                                                                                                                                                                                                                                                                                                                 |
| Chinook salmon                    | 100                | Raleigh et al. 1986                                      |                                                                                                                                                                                                                                                                                                                                                                 |
| Cutthroat trout                   | 100                | Hickman and Raleigh 1982                                 |                                                                                                                                                                                                                                                                                                                                                                 |
| Rainbow trout                     | 100                | Raleigh et al. 1984                                      |                                                                                                                                                                                                                                                                                                                                                                 |
| Reptiles and amphibians           | 100                | Rudolph and Dickson 1990                                 |                                                                                                                                                                                                                                                                                                                                                                 |
| <b>Instream Habitat</b>           |                    |                                                          |                                                                                                                                                                                                                                                                                                                                                                 |
| Minimal                           | 50 to 100          | Johnson and Ryba 1992                                    |                                                                                                                                                                                                                                                                                                                                                                 |

**Table 4.2-1. Riparian habitat buffer widths needed to protect riparian habitat functions (modified from Knutson and Naef [1997]) (continued).**

| Riparian Habitat Function       | Buffer (Ft) | Literature Sources        | Evaluation for Master Plan Update Mitigation |
|---------------------------------|-------------|---------------------------|----------------------------------------------|
| maintenance of most functions   |             |                           |                                              |
| <i>Mean Buffers<sup>a</sup></i> |             |                           |                                              |
| Temperature Control (90 ft)     |             | Filter Sediments (138 ft) |                                              |
| Large Woody Debris (147 ft)     |             | Filter Pollutants (78 ft) |                                              |
| Instream Habitat (50-100 ft)    |             |                           |                                              |

<sup>a</sup> Where a range of values was reported in the literature, the median of that range was used to calculate a mean.

The enhanced buffer is expected to provide nutrient and sediment removal functions from stream water during high-flow conditions when portions of it flood. The buffer is not expected to perform significant water quality treatment functions for urban runoff or runoff from adjacent uplands. Urban runoff from adjacent developed areas is treated by the stormwater management system, and not directed to the stream buffers for water quality treatment. Likewise, sources of sediment are not directed to the stream buffers for removal/filtration prior to discharging to the creek.

Since the buffer is not planned to support wildlife habitat, buffer widths for various wildlife species (Knutson and Naef 1997) are not relevant to the desired mitigation functions.

#### **4.2.3 Des Moines Way Nursery Wetland Restoration**

Mitigation goals for this site focus on restoring riparian habitat functions, restoring water quality functions, restoring organic matter export functions, and reducing the habitat value of the area to waterfowl and flocking birds. These functional changes will be achieved through wetland restoration, wetland and riparian enhancement, buffer restoration, and stream channel enhancement. The benefits of the mitigation to these functions are described in the below:

- **Fish and Aquatic Habitat**

The instream enhancements will improve habitat for fish and other aquatic organisms because of the new features that will be added to the stream that are currently lacking. The primary features provided are LWD and woody riparian vegetation. Each of these features will enhance fish and aquatic habitat (see Cederholm et al. 1997). Increased amounts of woody riparian vegetation will result in increased shade, allochthonous inputs (food sources in the form of CPOM and terrestrial invertebrates), and sources of woody debris. Increased LWD generally provides habitat complexity, including small plunge pools, fish cover, invertebrate substrates, variable water depths and velocities, etc. These conditions provide nesting, resting, and forage habitat for fish and other aquatic life. Increased streambed variability in the form of gravel, wood, and CPOM will also increase the diversity of invertebrate habitat. Buffer enhancement will increase the types and amounts (terrestrial insects, plant detritus, etc.) of organic matter inputs to the stream, thus increasing forage resources for fish and invertebrates. The role of riparian conditions and LWD on aquatic systems is extensively reviewed in Allen (1995),

Bisson and Bilby (1998), Bisson et al. (1987), Gregory et al. (1986), Harmon et al. (1986), Hershey and Lamberti (1998), Harmon et al. (1986), and Lassetre (1999).

- **Amphibian Habitat**

Restoring developed land to wetland conditions will improve conditions for amphibians by increasing the quality of vegetated habitat available to them. The wetland and buffer enhancements that replace lawns and buildings will improve conditions for amphibians by increasing and enhancing vegetated habitat available to them. This enhancement will provide improved habitat for adult terrestrial amphibians. Improved habitat for terrestrial breeding amphibians (e.g., red-backed salamander, ensatina) will be provided by increased amounts of forest vegetation and woody debris in the Miller Creek buffer and riparian wetlands (Brown 1985; Johnson and O'Neil 2001; Kauffman et al. 2001; Rose et al. 2001).

- **Small Mammal Habitat**

Planting riparian vegetation and restoring wetlands will improve habitat for small mammals by creating a diversity of forage and cover habitat for them. Increased woody vegetation and woody debris will provide denning and forage areas (Brown 1985; Johnson and O'Neil 2001; Kaufman et al. 2001; Rose et al. 2001). Restored wetlands and buffers will provide new habitat and resources wetland and upland dependent species.

- **Passerine Bird Habitat**

Planting tall shrubs and trees on the site will reduce foraging habitat for ground feeding birds. The buffer plants will provide limited direct food sources (i.e., fruits, nuts, seeds, berries, etc.) for avifauna, but will produce insects that a variety of passerine birds forage upon. While not a specific goal of the mitigation, the increased amounts of woody and forest vegetation will provide additional and improved habitat for forest-dwelling bird species.

- **Nutrient Retention and Sediment Trapping (Water Quality)**

Water quality functions of the buffer and riparian wetlands will improve for several reasons. Impacts to wetlands and the stream will be removed as a result of the demolition of commercial properties, removal of nursery areas, lawns, and parking areas. Removal of these land uses would remove activities that contribute to water quality degradation (Horner et al. 1994; Los Angeles County Department of Public Works, 2000; Steur et al. 1997; Bannerman et al. 1999; Minnesota Pollution Control Agency 2000).

The removal of development, fill, and detrimental land uses, coupled with the replacement of these areas with shrub and forest dominated wetland and riparian communities will promote nutrient uptake and storage in vegetation and soil organic matter. Establishing natural nutrient cycling pathways on the site will support water quality functions.

- **Organic Matter Export**

Replacing grass-dominated wetlands, fill, developed property, and managed riparian areas with wetlands dominated native woody vegetation will increase the export of particulate and



dissolved organic matter from wetlands to the stream. In many places, lawn vegetation will be replaced with tree and shrub vegetation. The higher productivity and greater structural diversity expected in the riparian wetlands will increase the amount and diversity of organic matter (i.e., insects, leaves, branches, trees, etc.) reaching the stream. Accumulations of soil organic matter due to slower decomposition of wood in the saturated soils are likely. The partial decomposition of organic matter in wetland environments would increase export to the stream as detritus and as dissolved carbon. Where riparian vegetation consists of lawn, its replacement with a multi-storied forest and shrub canopy will also increase the type and diversity of organic matter reaching the stream.

Placing LWD in the stream channel and removing riprap will result in the restoration of natural patterns of organic matter retention and cycling in the stream channel (Bisson et al. 1987; Harmon et al. 1986), as described in other sections above. This will support stream invertebrates and downstream fish communities.

Placing in-channel woody debris will improve overbank flow in some sections. This overbank flow, coupled with overhanging riparian vegetation, will provide additional sources of organic matter export into the stream channel. Where riparian wetland vegetation is currently lawn or blackberry, planting tree and shrub communities will increase the amount and diversity of organic matter available to the stream and wetlands.

The high productivity expected in forest and shrub wetlands will result in accumulations of organic matter in the saturated soil of the restored wetland. Groundwater movement through the site and flooding will continue, and would transport dissolved organic matter to Miller Creek (Fieberg et al. 1990; Emmet et al. 1994; Dosskey and Bertsch 1994).

- **Groundwater Exchange**

The mitigation area is predominantly a groundwater discharge area (as indicated the historical presence of peat soils [Rigg 1958; Paulson 1953]). Enhancement activities will not alter this hydrologic pattern. Restoration of portions of the site as wetland by removing fill will allow groundwater to support additional wetland habitat.

- **Flood Storage**

No changes to this function are planned at the site. Over time, the Miller Creek channel could migrate or meander through wetland restoration areas and it could expand its floodplain and flood storage capacity.

- **Waterfowl Habitat**

As directed by FAA, waterfowl habitat functions are not proposed at this mitigation area. The current lawn will be planted with trees and shrubs to provide a complete canopy cover that will prevent ground foraging by waterfowl. If any short duration flooding occurs on the site, a tree and shrub canopy that would prevent substantial waterfowl use would cover it.

#### **4.2.4 Functions Planned for the Tye Valley Golf Course Mitigation Site**

- **Fish and Aquatic Habitat**

Enhancement of floodplain wetlands and stream buffers will improve fish and aquatic habitat. Increased amounts of woody riparian vegetation planted in the wetland and buffer will result in increased shade and organic matter inputs to the stream, including food sources and woody debris that improves habitat (see Table 4.2-1). These conditions improve the quality of the stream for nesting, resting, and forage habitat for fish and other aquatic life. Restoration of floodplain wetlands (converting golf course vegetation to shrub wetland) will increase carbon production, some of which will be exported to the stream during flood events, rainy periods, or through movement in groundwater (in the form of dissolved organic carbon).

- **Amphibian Habitat**

The wetland and buffer enhancements that replace golf course turf grass will improve conditions for amphibians by restoring floodplain wetlands that provide habitat for terrestrial adult amphibians. Improved habitat terrestrial breeding species (e.g., red-backed salamander, ensatina) will be provided by the increased amounts of shrub vegetation and woody debris. The mitigation site will also improve amphibian dispersal because of improved connections to other riparian wetlands and Wetland 28.

- **Small Mammal Habitat**

Planting vegetation in riparian areas and restoring wetlands will improve habitat for small mammals by creating a diversity of forage and cover habitat compared to the existing turf grass. Increased woody vegetation and debris will provide denning and forage areas. The mitigation site will also improve amphibian dispersal because of improved connections to other riparian wetlands and Wetland 28.

- **Nutrient Retention and Sediment Trapping (Water Quality)**

Removing turf grass management from the wetland and buffer areas will remove sources of nutrients and pesticides. Planting shrub and forest vegetation will provide natural pathways for nutrient cycling.

- **Organic Matter Export**

Organic matter export functions will increase because currently organic matter is cut and removed from the floodplain as part of golf course activities. After enhancement is in place, organic matter could be exported from the wetland and riparian buffer during flooding and rainy periods. New woody vegetation and eliminating mowing of grass in the riparian zone will allow leaf-fall, herbaceous plants, and insects to reach es Moines Creek at levels higher than would be expected from gold course turf.

- **Waterfowl Habitat**

As directed by FAA, a waterfowl habitat function is not sought at this mitigation area. The current turf grass will be planted with trees and shrubs to provide a complete canopy cover that prevents ground foraging by waterfowl. Additionally, while portions of the site will flood during 1-year and greater storm events, the presence of standing water on the site will be for short duration, and obscured by vegetation. Thus, it will not attract wildlife.

- **Passerine Bird Habitat**

The wetland and buffer plants will provide limited direct food sources (i.e., fruits, nuts, seeds, berries, etc.) for avifauna to limit bird use, and restrict use by flocking birds. The buffers will produce insects that a variety of passerine birds will forage upon. While not a specific goal of the mitigation, the increased amounts of woody and forest vegetation will provide additional and improved habitat for forest-dwelling bird species.

Buffering Des Moines Creek and associated riparian wetlands with 100-ft average buffers will improve the function of the stream compared to baseline. For most functions of concern, the buffers will ameliorate temperature control and provide/protect in-stream habitat. In forested situations, WDFW recommends a width of 150 ft for maximum wood recruitment for streams. Project constraints do not allow for that width; therefore, some reduction in future delivery of woody debris to the stream compared to a mature forested buffer in an undisturbed area will occur.<sup>16</sup> Delivery of wood above the current baseline will be substantial because the current buffer is largely turf grass.

The enhanced buffer is expected to provide nutrient and sediment removal functions from stream water during high-flow conditions when portions of it flood. The buffer is not expected to perform significant water quality treatment functions for urban runoff or runoff from adjacent uplands. Runoff from adjacent developed areas is treated by the stormwater management system, and not directed to the stream buffers for water quality treatment. Likewise, sources of sediment are not directed to the stream buffers for removal/filtration prior to discharging to the creek. Since the buffer is not planned to support wildlife habitat, buffer widths are not relevant to the desired functions.

#### **4.2.5 Wetland Mitigation in Auburn**

Functions planned for the wetland mitigation site in Auburn are:

- **Waterfowl Habitat**

The Auburn mitigation site will create open water, submergent aquatic bed vegetation, and seasonally flooded emergent vegetation. These areas will provide a diversity of cover and food sources that will provide habitat for waterfowl, including feeding, resting, and nesting habitat.

- **Passerine Bird Habitat**

The Auburn mitigation site will provide multi-canopied forested, shrub, and emergent wetland communities. The complex vegetation structure and plant communities (containing vertical diversity, snags, debris structures, and food sources) will provide high quality habitat to a variety of forest and wetland bird species. These elements will provide resting, nesting, and foraging habitat for passerine birds.

---

<sup>16</sup> Since most areas located between 100 and 150 ft from the stream that are not currently included in the buffer lack tall trees, the reduction of this function would occur in future years, when any planted trees have grown to heights in excess of 100 ft in height. This could occur after 50 to 75 years.

- **Fish and Aquatic Habitat**

The Auburn mitigation area is not designed to provide fish habitat. Some warmwater fish may use the open water and flooded emergent portion of the wetlands.

- **Amphibian Habitat**

Creation of open water ponds with flooded emergent vegetation will provide breeding and rearing habitat for several amphibian species. The open water will provide habitat for the adult phases of aquatic species. Forested wetlands and upland buffers will provide habitat for terrestrial adult life phases. Mitigation includes placement of logs and other woody debris, and topographic diversity that will provide habitat structure for amphibians.

- **Small Mammal Habitat**

The existing tall grasses on the site provide good habitat for a variety of small mammals. Conversion of the area to forest and shrub wetlands will improve habitat for forest and wetland-associated mammals. The increased vegetation structure will provide a greater variety of denning areas, a greater diversity of food sources, and greater cover.

- **Nutrient Retention and Sediment Trapping (Water Quality)**

Mitigation consists of depression wetlands with a surface flow outlet. The large size of the wetland basins and relatively small amount of discharge water expected during most conditions will result in high retention rates for sediment and nutrients. The site will have a surface water connection to the Green River floodplain during flow events that exceed 8,500 cubic ft per second. At these flow levels, the wetland area will flood as a result of backwater conditions from the Green River. During flood events the wetland is expected to remove nutrients and sediments from floodwaters.

- **Organic Matter Export**

As the flood waters drain, fine particulate organic matter (FPOM) and dissolved organic matter will be exported to downstream systems via the ditch systems.

- **Groundwater Exchange**

The topographic variability of the mitigation area will provide areas of seasonal groundwater discharge.

- **Flood Storage**

The Auburn mitigation site design connects it hydrologically to the Green River floodplain via a series of ditches. The site is designed to store approximately 50 acre-ft of floodwater during 100-year flood events.

The specific wildlife species targeted for the mitigation site are listed in Section 7.2.5.4. The habitat conditions at this site, including the 100-ft buffers, provide suitable habitat for all these species. The quantity and quality of the approximately 50 acres of wetland and over 15 acres of protective buffer exceeds that of the 18.37 acres of wetland habitat impacted at STIA. While some species do not frequent the affected wetlands near STIA and may require buffers in excess of 100 ft for optimal

habitat, the mitigation site will accommodate their use. On the Auburn site, more wildlife species most sensitive to disturbance are expected to use the interior portions of the site that are most secluded (about 37 acres of interior habitat are more than 200 ft from the perimeter of the site). Regardless, for the species of birds using wetlands near STIA, improved habitat functions will occur because wetland buffers of the impacted wetlands are generally absent or much less than 100 ft.

### **4.3 MONITORING PLAN AND CONTINGENCY MEASURES**

Effective monitoring, adaptive management, maintenance, and contingency actions are planned to evaluate and assure performance standards are met, and to correct deficiencies if needed. Monitoring and reporting monitoring results for agency review and concurrence will assure that appropriate contingency actions are taken and ecological benefits are ultimately achieved. This section describes mitigation site monitoring that will occur over a 15-year period to verify that each project is meeting established performance standards and permit conditions. The monitoring approach for all mitigation projects is described here and will be performed in accordance with all conditions of the *401 Water Quality Certification* (Ecology 2001a). Specific monitoring requirements for individual projects are included in Section 5 (on-site mitigation) and Section 7 (off-site mitigation). If monitoring demonstrates that performance standards are not met, then contingency actions will be evaluated and implemented to assure that the desired wetland functions are ultimately provided by the mitigation projects.

#### **4.3.1 Monitoring Approach**

The monitoring plan describes steps that the Port will take to ensure that the mitigation projects meet design goals, objectives, performance standards, and permit conditions. Monitoring will be used to evaluate conditions at each mitigation site relevant to mitigation success, including overall site conditions, site hydrology, vegetation, wildlife, invasive species, and when applicable for specific projects, channel morphology and instream habitat features. Parameters commonly used to predict ecological functions (such as percent cover of native vegetation, percent survival of planted stock, channel bed material size distribution, channel profiles, density of LWD in streams, and frequency and size of pools in streams) will be measured. These measurements will be used to quantify site conditions and allow comparisons with performance standards.

Performance standards will be measured using standard field techniques, and thus will be enforceable by permitting agencies. Performance standards developed for the Port's mitigation plan reflect reviews made by ACOE and Ecology.

Monitoring results will be used to evaluate appropriate contingency measures in cases where performance standards are not met. Contingency measures will be implemented following an adaptive management approach, described in Section 4.3.2. The adaptive management approach depends on monitoring data to:

- Evaluate the locations and need for contingency measures.
- Develop appropriate contingency measures.
- Adapt contingency measures as necessary to meet performance standards.
- Evaluate the success of contingency measures following implementation.

If at any point during the monitoring period the results of monitoring show that the success criteria established in the plan are not being met, Ecology may require corrective action, additional monitoring, and additional mitigation.

Ecology or ACOE may require contingency measures and additional monitoring of the mitigation areas if wetland monitoring reveals that vegetation establishment or wildlife use of the wetland is not sufficient to meet the success standards. Additional monitoring may be required beyond the 15-year period if mitigation success is not achieved within the monitoring period.

#### **4.3.1.1 Monitoring Periods**

##### **Pre-construction Monitoring**

Mitigation sites will be monitored before, during, and after mitigation construction. The Port has conducted regular monitoring of the acquisition area during the acquisition and mitigation design phases to ensure that no wetlands or aquatic resources are impacted by nearby construction or survey activities. Pre-construction monitoring includes steps such as ensuring that wetlands and/or stream boundaries are clearly marked or fenced, inspecting sediment and erosion control measures, and conducting regular site inspections to ensure that construction or survey operations are avoiding wetlands and streams. In addition, groundwater hydrology monitoring will be initiated in wetlands near the new embankment and borrow areas prior to project construction to allow the Port to evaluate any potential indirect impacts. This monitoring will meet all conditions of the *401 Water Certification* (Ecology 2001a). The monitoring will allow the Port to detect potential indirect hydrology impacts that may affect wetland functions. If needed, appropriate contingency measures to maintain hydrology in wetlands will be implemented.

The Port shall monitor hydrologic conditions of all wetlands downslope of the Third Runway embankment in the Miller, Walker, and Des Moines Creek sub-basins. Hydrologic monitoring using piezometers and shallow hand dug soil pits in undisturbed wetlands downslope of the Third Runway embankment shall be conducted with sufficient frequency to determine wet season trends. The Port will conduct twice monthly hydrologic monitoring during the wet season, November through May, and will continue such monitoring for at least three (3) years after completion. Maps of sample locations and vegetation in the surrounding areas, observations of stressed vegetation, any adaptive management actions implemented in the surrounding areas, a comparison to baseline data, and conclusions will be documented and submitted to Ecology on a monthly basis during that period. At the end of each water year, the Port will complete a trends analysis with proposed contingency measures identified to supplement wetland hydrology, if such is required. A schedule for completion of proposed contingency measures, if any are required, will be provided.

A similar groundwater-monitoring program will be completed in wetlands near Borrow Areas 1 and 3. In Borrow Area 1, Wetlands 48, B15, 32, B12, B4, and B1 will be evaluated. In Borrow Area 3, all wetlands will be avoided, but special emphasis shall be given to the area near where the drainage swale discharges into Wetland 29, to provide an early indication of hydrologic changes, if any to the wetland.

### **Construction Monitoring**

The Port will also monitor all mitigation sites during construction. Construction monitoring is essential to ensure that mitigation designs are implemented according to plans and specifications in this mitigation plan, and in the final construction documents. Construction monitoring will also ensure that construction activities are consistent with federal, state, and local permit conditions. Construction monitoring will include regular and periodic inspections of the project site, regular meetings with contractors, and site visits during implementation of critical design elements (e.g., diverting flows to the new Miller Creek channel). Inspection activities during regular visits will, for example, verify that appropriate sediment and erosion control measures are in place, plants are being installed correctly and consistent with the plans, and habitat features are installed consistent with the plans. If changes to the planting design or plant schedule are required (as a result of new information about site conditions), they will be reviewed and approved by the wetland scientist or landscape architect appointed by the Port prior to implementation. Any modifications that affect the ability of the project to meet performance standards will be presented to ACOE and/or Ecology for approval prior to implementation.

Construction monitoring will also ensure that elements of mitigation construction are coordinated with other site activities. Because mitigation construction will often be coordinated with Master Plan Update improvement construction activities, construction monitoring will also ensure that Master Plan Update construction-related activities do not result in impacts to mitigation sites. For example, mitigation planting zones that are adjacent to Master Plan Update construction sites (e.g., Miller Creek relocation and South 154<sup>th</sup> Street relocation) will be protected and monitored to ensure that plants installed on the mitigation sites are not damaged or disturbed by Master Plan Update construction.

### **Post-construction Monitoring**

Baseline monitoring data will be collected following completion of mitigation construction. The baseline monitoring report will include a summary of site conditions immediately following mitigation construction, as well as documentation of the protocol to be used to monitor the mitigation sites (e.g., sampling methodology, locations of all monitoring wells, photo points, vegetation sampling plots). Post-construction monitoring methods, parameters to be measured, and specific monitoring schedules for each of the mitigation projects are included in this document in the individual sections describing each mitigation project (Sections 5 and 7).

All mitigation projects will be monitored for a 15-year period following completion of mitigation construction and approval of Record drawings (i.e., 'record' drawings) by the agencies. Monitoring will take place during years 0 (baseline), 1, 2, 3, 5, 7, 10, 12, and 15. Monitoring reports will be submitted to ACOE and Ecology each year that monitoring is conducted.

Consistent with condition D1 s of the *Water Quality Certification* (Ecology 2001a), the Port shall notify Ecology and ACOE a minimum of 3 days in advance of field monitoring work. Ecology or its designee will be allowed access to all mitigation sites during the 15-year monitoring period.

#### **4.3.1.2 Monitoring Reports**

The Port will prepare and submit annual monitoring reports to ACOE and Ecology's Federal Permit Manager, SeaTac Third Runway, Northwest Regional Office, no later than December 31<sup>st</sup> of each year following the first year of the mitigation site work. These and other reporting requirements are discussed further in this section.

#### **Construction Monitoring**

Construction monitoring by wetland ecologist and the project engineer will occur to ensure the mitigation is constructed according to the approved plans and specifications provided in this document. Also during construction monitoring, mitigation sites will be examined for yard and other waste, including hazardous waste<sup>17</sup>, that may have been left by previous landowners. Small amounts of waste occur on some sites (e.g. wood debris, concrete blocks, tires, etc.), and as these items are encountered during implementation, they will be removed from the mitigation area and disposed of in appropriate upland areas.

Consistent with condition D1-q of the *Water Quality Certification* (Ecology 2001a) construction monitoring shall also include field inspection by a qualified wetland consulting biologist during construction and planting to ensure proper installation.

#### **Baseline Monitoring Report**

On completion of construction for each mitigation project, record drawings and baseline (record) monitoring report will be submitted to EPA, USFWS, Ecology, and ACOE. These will document the final design of the mitigation sites and any minor changes to mitigation plans that may have occurred during construction.

A baseline monitoring report will also be prepared to document initial post-mitigation site conditions for hydrology, wildlife, vegetation, invasive species, channel morphology, and instream habitat features for each mitigation project as they apply. These baseline conditions will allow the Port and agencies to evaluate changes on the mitigation site over time, progress toward meeting mitigation objectives, and final performance standards.

The baseline report documenting the final design of all wetland mitigation sites shall be prepared when the initial planting is completed. The report shall include discussions and record drawings of the following:

- Site boundaries
- Location of perimeter fencing and signs
- Photographs of the area taken from established permanent reference points (see Appendix I)
- A planting plan showing species, densities, sizes, and approximate locations of plants, as well as plant sources and the time of planting

---

<sup>17</sup>Sites have been evaluated for hazardous wastes during the acquisition and demolition phases of the project and all known hazardous wastes have been appropriately removed.



- Habitat features (snags, large woody debris, etc) and their locations
- Drawings in the report shall clearly identify the boundaries of the project
- Locations of sampling and monitoring sites
- Any changes to the plan that occurred during construction, and
- Plans showing locations of all monitoring transects

Monitoring reports shall show all sampling locations, discuss trends and changes, discuss success in achieving performance standards or other implementation difficulties, provide remedies to address implementation problems, and set forth a timeline for their resolution. Supporting data and calculations shall be maintained by the Port and made available to Ecology and ACOE upon request.

The As Built Report shall be sent to Ecology's Federal Permit Manager, SeaTac Third Runway within sixty (60) days of completing the mitigation site.

Any proposed changes to the wetland mitigation and monitoring protocol established in this report and the Water Quality Certification (Ecology 2001a) must be approved in writing by Ecology and/or ACOE prior to implementation of any changes.

A report including the record drawings of the mitigation site and locations of monitoring sampling locations will be submitted within 60 days of completion of the final planting for a given mitigation site. The baseline monitoring report will be submitted within 120 days of the completion of the final planting for a given mitigation site.

#### **Post-construction Monitoring Reports and Reporting Schedule**

Monitoring of all mitigation sites (including temporary impacts that involve fill or clearing of vegetation in wetlands) will be conducted for a period of not less than 15 years, consistent with the monitoring plans, methods, and schedules described in this document and required by the *401 Water Quality Certification* (Ecology 2001a). Regular monitoring periods for post-construction monitoring will be in years 0 (baseline), 1, 2, 3, 5, 7, 9, 10, 12, and 15. Monitoring reports will summarize the data collected during each monitoring period. Reports will also compare results from each monitoring period to baseline conditions, previous monitoring year results, and performance standards, and discuss any recommended contingency actions. Monitoring reports will be submitted by the end of the year (i.e., December 31<sup>st</sup>) of each monitoring period, or at a time mutually agreed upon by the Port and agencies. Monitoring schedules specific to each mitigation project are included in the individual project descriptions in Sections 5 and 7 of this document.

Each monitoring report shall include photographic documentation of the projects taken from permanent reference points (see Appendix I). Existing wetland and mitigated wetland boundaries (including all areas down slope of the Third Runway embankment, Vacca Farm, the borrow sites, and the Auburn mitigation site) will be delineated at years 5, 10, and 15. A licensed survey crew will survey and map the wetland delineation points established. The delineation map and comparisons to previous delineation maps will be furnished to Ecology and ACOE by December

31st in each of the year that a delineation is required. If the delineation shows the wetland boundaries have decreased then additional on-site mitigation may be required by Ecology.

### **Reporting of Hazard Wildlife Monitoring Results**

In addition to performance monitoring that will be conducted specifically for the mitigation sites, the Port conducts regular monitoring as part of the WHMP. Monitoring activities and results regarding hazard wildlife in the area of the mitigation projects will be included as an attachment to the mitigation monitoring reports. The purpose of this attachment will be to document the status of the mitigation projects near the airport with regard to hazard wildlife.

#### **4.3.1.3 Monitoring Methods**

##### **Hydrology**

Groundwater and/or surface water hydrology will be monitored at mitigation sites for a 15-year period following completion of all mitigation construction. The hydrology in wetlands located adjacent to the runway embankment, SASA, Borrow Area 1, and Borrow Area 3 will also be monitored. The primary purpose of monitoring groundwater levels in mitigation areas is to verify that groundwater, which maintains wetland conditions on most of the mitigation sites, is present and continues to support wetland conditions. The evaluation will include determining that groundwater levels and periods of saturation are sufficient to support the wetland plant communities present on each site. Wetland hydrology in wetlands adjacent to the Master Plan Update improvements will be monitored to verify that indirect impacts to wetland hydrology do not occur, and to implement contingency actions if they are found. Permanent groundwater monitoring wells will be installed to monitor seasonal groundwater levels at each site. Monitoring wells will be installed by a licensed well driller and recorded with Ecology. Groundwater hydrology will be measured in each planting zone and in all wetlands at each mitigation site. Well locations will be surveyed and included on site base maps. Well locations will be shown on the record drawings.

Depths to groundwater will be measured monthly during the first 3 years following completion of grading and then seasonally (i.e., four times a year) thereafter. These data will be used to evaluate the depth, frequency, and duration of inundation and/or soil saturation on the mitigation sites, and determine whether wetland hydrology performance standards are met. These data will also be used to determine appropriate contingency measures if performance standards are not met, and to evaluate adaptive management or maintenance needs.

Groundwater monitoring will also be used to evaluate any potential indirect impacts to wetland hydrology in wetlands between the new third runway embankment and Miller Creek, and wetlands downslope of the borrow areas. Master Plan Update improvements have been designed to avoid and minimize any indirect impacts to wetland hydrology, and hydrology in these wetlands will be monitored to verify that indirect impacts have not occurred.

Surface water levels and/or flows will be monitored at selected mitigation sites where flow rates or the extent, frequency, or duration of inundation are important components of the mitigation (e.g., Miller Creek channel relocation, replacement drainage channels, Auburn open water habitat, Wetland 30 near Borrow Area 3). Surface water levels will be evaluated using staff gages. Surface

water depths and/or flow rates will be measured during regular monitoring visits. Flow rates will be measured using depth and velocity methods.

### Wetland Indicators

Wetlands at each mitigation site will be evaluated to verify that these areas continue to meet jurisdictional wetland criteria following mitigation. Methods consistent with ACOE 1987 Manual (Environmental Laboratory 1987) for delineating wetlands will be used to verify that hydric soils, hydrology indicators, and hydrophytic vegetation are present in the wetland areas.

### Vegetation

Vegetation monitoring will be used to determine if native plant communities are established in accordance with the specific performance standards for each site, and to provide guidance for the implementation of contingency measures when necessary. A range of variables will be evaluated, including percent survival, canopy cover by strata, height by strata, number of vegetation strata, species composition and richness, evidence of herbivore damage or disease, recruitment (i.e., the number of newly establishing individuals), canopy cover, and number of invasive, non-native species.

Immediately after completion of plant installation, the landscape architect or wetland scientist will inspect the site to evaluate the planted stock for overall health. If necessary, re-planting will be recommended to ensure that the site has been planted according to the plans and specifications. Following this inspection, record drawings will be completed to show the location of the installed plant material, the species composition, density and spacing of plants in each planting zone, and average height of each strata in each zone. Permanent vegetation photo points, sampling plots, and/or transects will be established in the field and shown on the record drawings. Vegetation data will be collected to establish baseline conditions on the monitoring site. Record drawings and baseline conditions establish a benchmark against which future changes in the vegetation can be compared. The photo points will provide a visual representation of plant cover, species composition, and general health.

The timing of the baseline monitoring will depend on construction schedules, and subsequent monitoring visits will be scheduled such that at least one full growing season occurs between monitoring dates. Vegetation sampling should occur in the late spring or early summer (June through early July). A combination of plot and plotless vegetation sampling techniques will be used following standard vegetation sampling protocols (e.g., Elzinga et al. 1998; Kent and Coker 1994). Vegetation sampling plots and/or transects will be located to ensure a representative sample of the entire mitigation site (i.e., in each planting zone, in representative locations throughout the site).

Plant survival is a key indicator of the success of native vegetation establishment and of the maintenance of target densities on the mitigation sites. A minimum survival rate of 80 percent for planted stock (calculated as percent of original individuals planted) will be required for the first 3 years of the monitoring period.

Due to the difficulty in locating and tracking individual plants over time, plant cover rather than survival or density will be evaluated following year 3. After year 3, cover of native species will more accurately reflect the ultimate habitat conditions desired on the mitigation sites. After year 3,

performance standards will target a density and/or cover measure so that plant abundance can be evaluated even if plant numbers cannot be accurately estimated. Vegetation cover performance standards have been developed from observations of plant growth at various wetland and non-wetland locations in King County, and from monitoring data presented in *Auburn Racetrack-Year Four Monitoring Report* (Shapiro and Associates 2000). The performance standards for vegetation cover at all mitigation sites increase throughout the monitoring period, as listed in Table 4.3-1).

**Table 4.3-1. Performance standards for vegetation cover (minimum percent) by vegetation zone and monitoring year.**

| Monitoring Year | Vegetation Zone     |                    |           |         |                  |
|-----------------|---------------------|--------------------|-----------|---------|------------------|
|                 | Forest <sup>a</sup> | Shrub <sup>a</sup> | Emergent  |         | Invasive Species |
|                 |                     |                    | Hydroseed | Planted |                  |
| 0               | -                   | -                  | 0         | 0       | <10              |
| 1               | -                   | -                  | 50        | 10      | <10              |
| 2               | -                   | -                  | 60        | 20      | <10              |
| 3               | 10                  | 10                 | 70        | 30      | <10              |
| 5               | 25                  | 40                 | 80        | 50      | <10              |
| 7               | 40                  | 65                 | 80        | 70      | <10              |
| 10              | 80                  | 80                 | 80        | 80      | <10              |
| 12              | 80                  | 80                 | 80        | 80      | <10              |
| 15              | 80                  | 80                 | 80        | 80      | <10              |

<sup>a</sup> Vegetation cover will not be monitored in forest and shrub plant communities during monitoring year 0, 1, or 2. During these years, plant survival performance will be monitored and at year 3, survival must be 80 percent of the original numbers planted. Invasive plant species cover will be monitored during all monitoring years.

Natural colonization on the mitigation site is an important measure of the success of the mitigation. Plants that colonize the site (i.e., recruitment) following mitigation construction will be included in several of the variables used in the vegetation monitoring (e.g., density, species composition and richness measures, and percent cover).

### **Wildlife**

Port wildlife managers will monitor the mitigation sites near STIA to determine hazard wildlife use (USDA 2000). Mitigation areas will be monitored according to the Port's WHMP. Information obtained from the hazard wildlife studies will be used to determine hazard wildlife use of the mitigation area and any conflicts with FAA requirements regarding wildlife attractants near airports. Monitoring activities may include seasonal bird counts to determine levels of use and presence/absence of specific avian species. If results of the monitoring activities suggest that hazard birds are using the mitigation site, corrective actions regarding planting schemes and/or hydrologic regimes may be implemented following procedures identified in the WHMP. Any measures to control hazard wildlife that are recommended as a result of this monitoring will be reported to the agencies in the regular post-construction monitoring reports to ACOE and Ecology.

Mitigation sites will also be monitored for non-hazard wildlife (e.g., amphibians) during annual monitoring visits. Wildlife will be evaluated by assessing wildlife habitat components (i.e., vegetation structure, diversity, and cover, or habitat elements such as coarse woody debris), and to determine if performance standards are met. There are no performance standards that require

monitoring wildlife use or populations. However, during monitoring visits, observations of wildlife will be made and reported rather than directly sampling wildlife populations.

### **Channel Morphology and Instream Habitat**

Channel morphology and instream habitat will be evaluated using standard methods of stream ecology (e.g., Bain and Stevenson 1999; Hauer and Lamberti 1996). These methods will be used to measure variables such as channel profiles, cross sections, substrate size, type and amount of LWD, canopy cover from riparian vegetation, and type and number of habitat features (e.g., undercut banks, side channels, pools). Channel morphology and instream habitat features will be evaluated during regular monitoring visits, as well as following storm events. In addition, biological monitoring will be conducted in Miller Creek to evaluate changes in the Benthic Index of Biotic Integrity (BIBI) over the 15-year monitoring period (Karr and Chu 1999). Visual inspections and photo documentation will also be used to evaluate channel morphology, the stability of habitat features, and evidence of erosion or scouring.

### **Sample Data Sheets**

Sample data sheets in Appendix I show the general format and type of information to be recorded during regular monitoring visits. These data sheets reflect typical measurements of hydrology, wildlife, photographic documentation, plant cover, and plant growth that will be measured during monitoring visits.

### **4.3.2 Adaptive Management Approach**

Implementation of contingency actions and other management activities on the mitigation sites will be based on an adaptive management strategy using performance standards to trigger contingency and management actions. “Adaptive Management” recognizes that since the best contingency and management actions cannot always be predicted in advance and for all potential site deficiencies; they are determined on a case-by-case basis. Monitoring results will be used to identify any areas in which mitigation sites are not meeting performance standards, evaluate the reason(s) performance standards are not being met, and design and implement appropriate contingency actions.

If necessary, the first step following monitoring will be to determine why performance standards are not being met, and to identify key contributing factors (e.g., unusual drought, inadequate hydrology, invasive species, or animal damage). Once contributing factors are identified, appropriate contingency measures to remove or ameliorate the contributing factors will be designed and implemented. Effects of contingency measures will be monitored to ensure they have the desired result. The results of monitoring the efficacy of contingency measures will be used to fine-tune or adjust contingency measures to increase their effectiveness. Any planned contingency actions, as well as the results of implementing specific contingencies, will be fully documented and reported in the regular post-construction monitoring reports. Additional information is provided in the following sections on the weed management strategy for all mitigation sites and the relationship of the WHMP (USDA 2000) to the mitigation sites in the Miller and Des Moines Creek basins.

The Port will provide Ecology and ACOE with written documentation of the implementation of any of the contingency measures and adaptive management measures that have been taken. Adaptive management measures must include temporary erosion and sedimentation measures approved by

Ecology. Any problems identified throughout the mitigation sites shall be immediately corrected. Implementation of corrective actions shall be done within the confines of the contingency measures identified in this report. All contingency measures shall be implemented with adequate TESC measures such that state water quality standards are not exceeded.

#### **4.3.2.1 Maintenance**

The mitigation projects are designed to be self-sustaining over the long term and are not anticipated to require significant routine maintenance following the 15-year monitoring period. However, during the monitoring period, some maintenance actions will be required on the mitigation sites. Both routine maintenance tasks (e.g., maintaining irrigation systems) and adaptive management/contingency measures (e.g., weed management, replacing plants) will be required during the monitoring period to ensure that overall objectives and goals are met.

Routine maintenance will include maintaining temporary irrigation systems, repairing or maintaining TESC measures, removing trash, repairing fences and signs, replacing dead plant material, maintaining herbivore deterrents (e.g., geese exclusion devices, herbivore collars), and methods for control of invasive plant species. For the first year following planting, the landscape contractor will be responsible for ensuring the health of planted material and replacing dead or severely stressed plant material. After the first year, the Port will be responsible for maintaining plants and will replace plants as needed based on performance standards and consistent with specified contingency measures. Additionally, if any of the trees planted in mitigation projects within 10,000 ft of STIA runways create prime roosting habitat for starlings, blackbirds, crows, or raptors, the Port may remove these trees to conform with FAA mandates regarding aircraft safety and bird hazards. In this eventuality, the Port will replace these plants with small trees or shrubs, consistent with the WHMP.

Routine invasive plant species control includes removing weed growth from areas of mulch or weed fabric around or between planted stock. Contingency measures that may be needed to meet the invasive species performance standard for re-vegetated areas (no more than 10 percent cover at monitoring year 15) are discussed below under contingency measures.

Routine maintenance, including weeding, removal of invasive species, and watering, shall occur at least twice a year in all mitigation areas and more often as needed. The maintenance crew shall be overseen by a wetland biologist to assist with identifying invasive species and other problems.

The need for maintenance is anticipated to decline during the monitoring period, as the mitigation has been designed to be self-sustaining in the long term. Maintenance will continue as needed for the monitoring period (i.e., at least 15 years).

#### **4.3.2.2 Phasing of Conifer Plantings**

The landscape plan for each mitigation area where coniferous trees are specified shows that the planting of these trees is phased (see landscape design sheets in Appendices A-F). It is anticipated that these conifers would be planted in a second planting phase coincident with replacement plantings that may be required to meet the year three performance standard for plant survival. At

this time, the conifer species would be planted. The trees will be positioned such that they receive some shade from adjacent plants (trees, shrubs, and groundcover). For the first growing season following this planting, soil moisture conditions will be examined closely, and the use of the temporary irrigation system may be extended for 1 year to reduce mortality and promote growth during the June to September period.

#### **4.3.2.3 Wildlife Hazard Management**

Monitoring and maintenance/contingency actions for the on-site mitigation areas adjacent to STIA will be coordinated with the Port's WHMP. The results of monitoring for hazard wildlife at the mitigation sites will be included in the mitigation monitoring reports submitted to regulatory agencies.

The mitigation and implementation plans have been designed to be consistent with the FAA-approved WHMP, while providing for the restoration of wetland and stream functions potentially impacted by the project. Because the specific requirements of the WHMP (e.g., choice of plant species) were incorporated into the mitigation designs to avoid wildlife hazards at the mitigation sites, it is not anticipated that alterations to the mitigation sites will be necessary to comply with the requirements of the WHMP. The Port will monitor the mitigation sites regularly as part of its routine hazard wildlife-monitoring program. Activities on the mitigation site for the purposes of wildlife hazard management would be consistent with permit conditions. The mitigation monitoring reports will identify hazard wildlife management activities (if any) on the mitigation sites.

In the event that the FAA determines that mitigation measures have created a wildlife hazard to aircraft based on information obtained from the wildlife-monitoring program, the wildlife hazard will be addressed according to the WHMP. The process will be as follows:

- The FAA will consult with the United States Department of Agriculture – Wildlife Science Division (USDA-WSD) regarding the problem
- The USDA-WSD will recommend a list of strategies that can be used to eliminate the problem
- The Port and USDA-WSD will implement the strategies to eliminate the hazard
- Implementation will be consistent with the wildlife hazard, and depending on the nature of the action, agencies will be properly notified

The on-site mitigation areas are not planned as mitigation for impacts to avian or other wildlife species<sup>18</sup> that pose aircraft safety concerns. A critical need of the mitigation projects is to restore wetland and stream buffer functions in a manner that avoids creating new avian wildlife hazards and reduces existing avian wildlife hazards.

---

<sup>18</sup> As discussed in this document, wildlife habitat functions will be replaced by creating and restoring wetland habitats at an off-site location in WRIA 9, in Auburn. Non-avian wildlife using mitigation sites may be a hazard to aircraft safety if they attract avian predators, or move onto active runways.

As discussed in this plan, airport property is subject to a variety of potential wildlife management actions (regulations affecting wildlife management are explained in Sections 4.5 to 4.9 of the WHMP, and wildlife management control is discussed in Section 6 of the WHMP). In nearly all cases, these management actions can be successfully implemented without interfering with the ability of the on-site mitigation projects to provide the planned ecological functions. In nearly all cases, management actions at the on-site mitigation sites will involve hazing or removal of wildlife and minor habitat modification. These actions are consistent with the planned mitigation and require no wetland-related permits or approvals.

The wildlife management control actions presented in the WHMP attempt to balance the Port's, FAA's, and USDA WSD's role in protecting aviation safety with the goal of non-wildlife wetland mitigation and enhancement. Although the Port must retain ultimate authority to identify and respond to wildlife threats to aviation safety, the WHMP requires that:

- The Port secure permits and approvals for any control actions that would result in a significant reduction in mitigation functions, except where immediate action is required to ensure air safety.
- Any control action that results in a significant reduction in mitigation functions must be compensated for and mitigation functions must be restored as soon as practicable.

Regarding the mitigation sites, the WHMP contemplates two levels of wildlife management actions: those that may have a de minimus reduction in mitigation function, and those that may cause a significant reduction in mitigation functions.

#### **Minor Vegetation Management Activities**

This level of management activity includes vegetation management in mitigation sites that will not result in a significant reduction of mitigation functions, will not require a permit, and will not require a change to an existing permit condition. As a rule of thumb, this will generally include actions that do not alter the ability of a mitigation site to meet performance standards for vegetation, as identified in the mitigation plan. These actions will be exempt from pre-consultation with the permitting agencies. Examples of such management actions include:

- Selective trimming of vegetation. If selective trimming of vegetation within mitigation sites is required, it can occur without disruption of the desired functions of the mitigation. Removal of small quantities of vegetation can also occur when mitigation functions are not significantly altered.
- Increase vegetation density. Adding new non-attractive native plants to mitigation sites would increase plant density and reduce poorly vegetated areas. This action would reduce wildlife use of more open areas and increase the rate of canopy closure over periodically flooded floodplain areas.
- Replant or replace one type of vegetation with another native plant species. If one vegetation type is observed to be a wildlife attractant, it shall be replaced with another type. Replacement could occur through physical removal (cutting, up rooting, etc.) or by replanting areas with faster growing species that may out-compete less desirable plants.



Generally, replacement can occur without significant soil disturbance and without affecting the planned wetland functions.

- **Removal of channel obstructions.** Various debris blockages (including beaver dams) could increase the presence of standing water at the mitigation sites. To reduce standing water areas and habitat for waterfowl, it will be necessary to remove these obstructions.

The above vegetation management actions, if performed, will be reported in the mitigation monitoring reports, required for the Master Plan Update Clean Water Act Section 404 and Section 401 permit. Reporting will include a description of the action taken, an explanation of why the action was taken, an analysis of the effect of the action on the mitigation site properties, performance standards, and ecological functions. Photographs of the mitigation site prior to and following the management action will be included. An analysis of the effectiveness of the management action in eliminating or reducing the wildlife hazard will also be reported.

### **Potentially Significant Management Activities**

This level includes wildlife management activities that require permits from agencies regarding Clean Water Act Section 404 and Section 401 compliance, ESA review, Hydraulic Project Approval (HPA) review, and other applicable laws, or changes to conditions of existing permits and approvals. In the unlikely event that wildlife management activities result in significant modifications to non-habitat wetland functions, the Port would apply for the required permits or permit changes prior to conducting these activities, unless immediate action was required to ensure aircraft safety. If the Port determines that immediate action is required to ensure air safety, the Port will notify ACOE, Ecology, and other agencies with permitting jurisdiction at the earliest practicable date to consult with them on the actions taken and to be taken. This consultation would also determine the appropriate mitigation(s) necessary to restore the lost or impaired mitigation functions.

Recognizing that activities that would result in a significant reduction in mitigation functions should be employed only as a last resort, the Port will be required to restore the lost or impaired mitigation functions at a ratio of at least 1.5 acres of mitigation to 1.0 acre of impact and to secure any required permits for the mitigation.

Examples of such management activities include:

- **Netting of habitat.** A potential management strategy to reduce bird use is to use a pole-supported net system that would reduce bird access to habitat. Placement of physical structures in wetlands, such as support posts, cable anchors, etc. could be subject to HPA and Section 404 permitting.
- **Drainage of wetlands.** Alteration of soil saturation or the extent of jurisdictional wetlands on mitigation sites through excavation of drainage channels, grading, or other hydrologic modification.
- **Significant removal/replacement of vegetation** such that planned mitigation functions could be altered. This could occur if larger scale removal/replanting affected riparian conditions, reduced shading of creeks, or changed other factors important to the mitigation function. As a rule of thumb, significant removal/replacement of vegetation will generally

include actions that result in removal of vegetation cover in a mitigation area such that the vegetation performance standards for the mitigation site cannot be met.

#### 4.3.2.4 Integrated Weed Management

An integrated weed management strategy will be used at all mitigation sites to allow successful establishment of native vegetation and prevent long-term dominance of the site by invasive and non-native plants.<sup>19</sup> The goal of the weed management plan can be accomplished by a combination of the following steps:

- Reducing existing on-site sources of invasive non-natives by measures such as stripping the soil surface to remove above and below-ground plant parts, mowing, and/or applying herbicide consistent with the *Biological Opinion* for the Master Plan Update (FWS 2001).
- Planting rapidly growing native species that will quickly establish cover and shade on the mitigation site to reduce weed invasion in the short-term.
- Using hydroseed to establish an initial “weed barrier” and to provide initial plant cover on the site, and reduce colonization by invasive species.
- Monitoring the site for new weed invasions and controlling or removing invasive species before they are allowed to dominate the site.

Control of invasive plants will be most important during the initial years (i.e., years 1 through 7) of the monitoring period while the native vegetation is becoming established. Control methods include, but are not limited to, using manual/mechanical methods to mow, cut, grub, or girdle plants, and selective use of EPA-approved herbicides.<sup>20</sup> Use of herbicides will be minimized. However, limited herbicide use in combination with other control methods may be necessary to control some of the aggressive invasive species likely to occur on the site (see Table 4.3-2).

**Table 4.3-2. Invasive plant species that will be monitored and controlled on the mitigation sites.**

| <i>Scientific Name</i>        | <i>Common Name</i>   |
|-------------------------------|----------------------|
| <i>Convolvulus sepium</i>     | Hedge bindweed       |
| <i>Cytisus scoparius</i>      | Scot's broom         |
| <i>Lythrum salicaria</i>      | Purple loosestrife   |
| <i>Phalaris arundinacea</i>   | Reed canarygrass     |
| <i>Polygonum cuspidatum</i>   | Japanese knotweed    |
| <i>Polygonum sachalinense</i> | Sachaline            |
| <i>Rubus discolor</i>         | Himalayan blackberry |
| <i>Rubus laciniatus</i>       | Evergreen blackberry |

<sup>19</sup> The plan assumes that complete eradication of non-native plants, especially invasive non-native plants, is not possible because the mitigation sites are surrounded by large sources of non-native seeds. A variety of bird species are also expected to import native and non-native plant species to the sites. The presence of non-native species will likely be a permanent feature of the mitigation sites.

<sup>20</sup> Herbicide used will be EPA approved, and applied by licensed applicators. Herbicides will be limited to those that are non-toxic to aquatic organisms. The most likely candidate for application to kill blackberry and reed canarygrass is glyphosphate. This herbicide has been evaluated by Ecology (2000) and others (Extoxnet 1996) and found to be protective of aquatic life for this purpose (FWS 2001).

#### **4.3.2.5 Fencing and Signage**

The boundaries of the mitigation area and buffers shall be permanently marked with stakes at least every 100 feet and/or with fencing. The marking shall include signage that clearly indicates that mowing and fertilizer/pesticide applications are prohibited within mitigation areas. The locations and types of fencing is shown in Appendix P.

#### **4.3.2.5 Contingency Measures**

Specific contingency measures have been developed for each performance standard at each mitigation site. Contingency measures will be implemented following the adaptive management approach in cases where performance standards are not being met. Proposed contingency actions will be fully discussed in monitoring reports submitted to the agencies, and all contingency measures will be monitored and evaluated to verify that they are achieving the desired result. Project-specific contingency measures are included with the individual project descriptions in Sections 5 and 7 of this document. The Port will consult with ACOE and Ecology prior to implementing any additional contingency measures that may be required, but that are not included in this document.

Control of invasive non-native plant species will likely require contingency measures on most of the mitigation sites during the first several years following construction. Specific control measures will depend on the invasive species of concern and site conditions. The Port will use an integrated, adaptive weed management strategy to control invasive non-native species on the mitigation sites. This strategy is explained in Section 4.3.2.4.

Independent of the potential for temporary netting to reduce wildlife hazards (Section 4.3.2.3 and the WHMP), temporary netting may be needed to reduce damage by grazing waterfowl. Temporary netting or other temporary enclosure systems could be supported 1 to 2 ft above the ground surface in emergent wetland areas to reduce damage by geese or other waterfowl.



## 5. ON-SITE MITIGATION PROJECTS

This section describes on-site mitigation projects that are designed to restore and enhance physical and biological functions in Miller and Des Moines Creeks and nearby wetlands. The Port will provide on-site mitigation in both the Miller Creek and Des Moines Creek basins, a part of WRIA 9, to compensate for unavoidable project impacts to wetland, stream, and hydrologic functions. In developing this plan, the Port utilized agency guidance to identify on-site mitigation activities that will compensate for project impacts to wetland and stream functions. Elements of the mitigation plan are specifically targeted to restore on-site functions that will be impacted by the project. These include sediment and nutrient retention (water quality), organic carbon production and export, surface water storage (floodwater detention and storage), and aquatic habitat functions (e.g., instream aquatic habitat and riparian habitat).

The mitigation plan will result in increased functional performance of the wetlands, streams, and buffers in the mitigation sites relative to their degraded existing conditions. For example, wetlands currently dominated by non-native ornamental vegetation and turf grasses will be restored to forested systems containing a greater diversity of native species and habitats. Along Miller and Des Moines Creeks, water storage, nutrient and sediment retention, instream habitat, and non-avian wildlife habitat functions will all be improved relative to existing conditions.

The on-site mitigation projects are described below.

### ***Miller Creek Basin***

- Vacca Farm Mitigation: Miller Creek Relocation (Section 5.1.1), Vacca Farm Wetlands and Floodplain Restoration (Section 5.1.2), and Lora Lake Shoreline Enhancement (Section 5.1.3)
- Miller Creek Wetland and Riparian Buffer Enhancement (Section 5.2.1)
- Miller Creek Instream Habitat Enhancements (Section 5.2.2)
- Drainage Channel Replacement (Section 5.2.3)
- Restoration of Temporary Construction Impacts (Section 5.2.4)
- Miller Creek Basin Trust Fund for Watershed Rehabilitation (Section 5.2.5)
- Des Moines Way Nursery Wetland Restoration (Appendix N)

### ***Des Moines Creek Basin***

- Tyee Valley Golf Course Wetland Enhancement (Section 5.3.1)
- Des Moines Creek Buffer Enhancement (Section 5.3.1)
- Des Moines Creek Basin Trust Fund for Watershed Rehabilitation (Section 5.3.2)
- Preservation of buffer and wetlands near Borrow Area 3 (Section 5.3.3)

The section provide descriptions and plans for each on-site mitigation project. Section 5.1 describes relocation and restoration of a portion of the Miller Creek channel; restoration and enhancement of the Lora Lake shoreline; and restoration of wetlands, floodplain, and buffers on the Vacca Farm site. Section 5.2 describes mitigation projects to restore and enhance wetlands and riparian buffers along a 6,500-ft reach of Miller Creek, and to enhance instream habitat along this reach. In addition, mitigation actions to restore wetlands temporarily impacted by construction of the design and replacement drainage channels (Section 5.2) that mitigate for filling of existing ditches and drainage channels are described.

The restoration projects in the Des Moines Creek basin (Section 5.3) are designed to enhance existing wetlands on the Tyee Valley Golf Course and the riparian buffer along sections of Des Moines Creek. Plans to minimize and mitigate potential indirect hydrologic impacts to wetlands near the borrow areas are also provided.

For each mitigation project described in this section, the mitigation plans are organized following Ecology guidance (Ecology 1994a). The mitigation plan, goals, and objectives are introduced first, followed by a description of the project site, existing ecological conditions, the rationale for selecting the project, and any constraints on the proposed mitigation. Next the mitigation design is described in detail, with reference to figures and the plan sheets in Appendices A-F. Performance standards, monitoring schedules, and maintenance and contingency measures necessary to ensure mitigation success are described next. The final section for each project describes the specific construction steps, methods, and sequencing required to implement the mitigation design.

## 5.1 VACCA FARM MITIGATION

Mitigation actions at the Vacca Farm site are designed to enhance or restore approximately 19 acres of aquatic and riparian habitats. Mitigation actions restore natural channel morphology to Miller Creek, integrate the channel with its floodplain, remove bulkheads along the Lora Lake shoreline, remove fill from wetlands, restore functions to degraded wetlands and restore natural vegetation to poorly vegetated riparian and upland buffers (Table 5.1-1; Appendix A). These actions will enhance fish habitat in Miller Creek, improve water quality (provide shade, ameliorate elevated water temperatures, increase dissolved oxygen, provide inputs of organic matter, improve sediment retention, and remove potential sources of fertilizer or pesticide inputs), provide no net loss of floodplain storage, and enhance the diversity and complexity of wetland habitats. Mitigation projects in the Vacca Farm area have also been designed to reduce the potential wildlife hazards that currently exist on the site, consistent with FAA Advisory Circular 150/5200-33. The major mitigation elements for the Vacca Farm site include the following:

- Relocation of a channelized portion of Miller Creek
- Restoration of natural channel morphology and instream habitat to the relocated reach
- Restoration and enhancement of riparian buffers along Miller Creek
- Restoration and enhancement of floodplain wetlands on the Vacca Farm site
- Restoration and enhancement of upland buffers around the Vacca Farm site

- Restoration and enhancement of wetland areas and upland buffers along the Lora Lake shoreline
- Removal of fill and bulkheads from the Lora Lake shoreline, and restoration of a more natural shoreline along the lake

**Table 5.1-1. Summary of wetland and buffer mitigation areas at Vacca Farm.**

| Mitigation Area at Vacca Farm                                           | Wetland Area (acres) |
|-------------------------------------------------------------------------|----------------------|
| Wetland Restoration (prior converted and filled wetland near Lora Lake) | 7.60                 |
| Wetland Enhancement                                                     |                      |
| Wetlands (A1, A1a, A2, A3, A4)                                          | 1.59                 |
| Farmed Wetlands (1, 2, 3, 9, 10, 11)                                    | 0.73                 |
| Lora Lake shoreline                                                     | 0.32                 |
| Lora Lake aquatic habitat                                               | 3.06                 |
| <b>Subtotal</b>                                                         | <b>5.70</b>          |
| Buffer Enhancement                                                      |                      |
| Buffer (Des Moines Memorial Drive)                                      | 1.54                 |
| Stream Buffer (South 154 <sup>th</sup> Street)                          | 3.04                 |
| Lora Lake Buffer                                                        | 1.81                 |
| <b>Subtotal</b>                                                         | <b>6.39</b>          |
| <b>Total Restoration Area</b>                                           | <b>19.69</b>         |

### 5.1.1 Miller Creek Relocation and Channel Restoration Plan

To accommodate the embankment for the third runway, the RSAs, and the relocation of South 154<sup>th</sup> Street, approximately 980 ft of Miller Creek will be realigned and relocated. The new stream channel will be constructed approximately 200 ft west of the existing channel, through the Vacca Farm site. The channel reach to be relocated has been dredged and straightened, lacks complexity (e.g., straight uniform channel bed, no undercut banks, no side channels, no pool/riffle morphology, uniform silt substrate), has few instream habitat features (e.g., no LWD, no pools or backwater areas), and the riparian vegetation provides little shade or organic matter to the channel.

Relocating the stream will increase the channel length to approximately 1,080 ft. A low-flow channel will meander within a larger high-flow channel, and the new channel will include instream habitat features (e.g., LWD). The channel will be designed to be connected to the floodplain by overbank flooding with approximately a 1-year return interval. Channel banks will be planted with native shrub plant communities and the new channel will have a native forested riparian zone to ameliorate water quality and provide shade and LWD.

### 5.1.1.1 Goals, Objectives, and Design Criteria

The overall goals of this plan are to provide a new, longer stream channel with enhanced habitat features and a more natural channel morphology compared to the existing channel, which will be filled. The channel design is constrained by the existing high- and low-flow conditions in Miller Creek and the very gradual slope of the channel through this reach. The goals of the design are focused on the need for the relocated channel to continue to convey base flows, to maintain sufficient depths during summer low-flow periods for fish passage, to prevent deposition of fines and scouring to maintain fish habitat, and to allow flood flows greater than annual peak flows to overtop the channel banks and flow onto the floodplain. Specific goals for the design of the relocated channel are:

- The stream continues to provide base flow conveyance
- Minimum flow velocity remains high enough to minimize fine sediment deposition
- The new channel accommodates peak flows up to the 100-year flow with no net reduction of 100-year floodplain storage or floodway conveyance
- The new channel provides improved fish habitat
- The new channel replaces or enhances riparian habitat function
- The channel does not attract wildlife (such as waterfowl or flocking birds)

The goals are prioritized from the most critical hydrologic functions that the existing channel provides to enhancements that will improve channel and riparian habitat.

To implement the general goals identified above, specific objectives and design criteria were developed (Table 5.1-2). Specific performance standards, monitoring approach, and contingency measures for the channel relocation are discussed in more detail in Section 5.1.1.10.

**Table 5.1-2. Mitigation goals, design objectives, and design criteria for the Miller Creek relocation project.**

| Goals and Design Objectives                                                             | Design Criteria                                                                                                                                                                                                                                              |
|-----------------------------------------------------------------------------------------|--------------------------------------------------------------------------------------------------------------------------------------------------------------------------------------------------------------------------------------------------------------|
| <b>Goal 1: The stream will continue to provide base flow conveyance</b>                 |                                                                                                                                                                                                                                                              |
| Provide flow depths to allow fish passage, prevent fish stranding, and provide habitat. | Construct low flow channel 8 ft wide with 1:1 slopes and 0.5 ft deep to convey summer base flows.<br><br>Construct high flow channel 32 ft wide with side slopes of 2:1 (typical) from depths of 0.5 to 1.0 ft to provide capacity for wet season base flow. |
| <b>Goal 2: Low-flow velocity should minimize fine sediment deposition</b>               |                                                                                                                                                                                                                                                              |
| Minimize sedimentation with minimum flow velocity.                                      | The channel cross section will provide an average dry season base flow velocity that is greater than the silt transport velocity (0.7 ft/sec).<br><br>Design a natural channel with stable gravel bottom.                                                    |
| Minimize channel scouring at the maximum design flow velocity.                          | Channel flow velocity cannot exceed the gravel movement velocity (4 ft/sec) for the 100-year flow.                                                                                                                                                           |



**Table 5.1-2. Mitigation goals, design objectives, and design criteria for the Miller Creek relocation project (continued).**

| Goals and Design Objectives                                                         | Design Criteria                                                                                                                                                                                                                                                              |
|-------------------------------------------------------------------------------------|------------------------------------------------------------------------------------------------------------------------------------------------------------------------------------------------------------------------------------------------------------------------------|
| <b>Goal 3: The channel will accommodate peak flows, including the 100-year flow</b> |                                                                                                                                                                                                                                                                              |
| Accommodate the 100-yr peak flow.                                                   | Flows greater than the annual peak flow will overtop the channel and inundate the adjacent floodplain restoration area.                                                                                                                                                      |
| <b>Goal 4: The new channel will provide enhanced fish habitat</b>                   |                                                                                                                                                                                                                                                                              |
| Provide enhanced fish habitat without fish passage barriers.                        | Provide a natural channel configuration. Increase channel length by about 10 percent and create a meandering low-flow channel.<br><br>Provide habitat features, including instream features such as deflectors and overhanging logs as needed to maximize available habitat. |
| <b>Goal 5: The channel will replace and enhance riparian habitat function</b>       |                                                                                                                                                                                                                                                                              |
| Provide riparian habitat.                                                           | Provide a minimum 50-ft vegetated buffer on the east side of the channel.<br><br>Establish native vegetation along channel banks and the riparian zone of the new channel.                                                                                                   |
| <b>Goal 6: The channel will not attract wildlife</b>                                |                                                                                                                                                                                                                                                                              |
|                                                                                     | Densely plant woody vegetation along the new channel to cover open water and reduce use of the area by waterfowl.                                                                                                                                                            |

**5.1.1.2 Ecological Assessment of Miller Creek at Vacca Farm**

Overall conditions in the Miller Creek basin are described in Section 2. In this section, existing conditions at the Vacca Farm site relevant to the mitigation design are described in more detail. Miller Creek originates north of SR 518, flows south through the Miller Creek detention facility along the southeast side of Lora Lake, and then south along the eastern edge of the Vacca Farm site. The Miller Creek detention facility detains and stores floodwaters from the upper reaches of the Miller Creek basin during periods of high flow. Vacca Farm sits in a broad, flat valley of alluvial sands, silts, and peat soils located south of Lora Lake. Portions of Miller Creek have been channelized through the Vacca Farm site and straightened to improve drainage on the site. From the Vacca Farm site, Miller Creek continues south and west through residential areas and ultimately empties into Puget Sound (see Figure 2.1-2 and 2.2-1).

The Miller Creek channel between the Miller Creek detention facility outlet to South 156<sup>th</sup> Way has been dredged and straightened to drain wetlands for farmland reclamation. Topographic conditions, peat soils, and seasonally high water tables along this reach indicate that this area was historically a wetland. The channel currently overflows its banks with at least a 2-year frequency with full flow velocity of 1.7 ft per second (FAA 1996). Frequent flooding is primarily the result of limited channel capacity, in part due to channel slope.

Miller Creek is approximately 4 to 10 ft wide and 2 ft deep below the outfall of the Miller Creek detention facility. The bank is lined with large rocks in the upper segments near Lora Lake, and the channel has a very silty substrate. The section of the stream within the Vacca Farm site that will be

relocated is a ditched reach with a silty bottom substrate. Downstream of South 156th Way, the channel contains natural meanders that vary from approximately 5 to 10 ft in width and the substrate consists of areas of sand and gravel with some silt.

A side channel (ditch) in the Vacca Farm site runs parallel to and west of the main channel. The side channel does not drain runoff from a distinct subbasin area, nor does it provide additional channel capacity to the main channel. Rather, it provides positive drainage for a portion of the relatively flat farmland located west of Miller Creek.

### **Hydrology**

Urbanization and development of the watershed have led to increased runoff rates and volumes that have contributed to erosion and downcutting. Increased erosion and downcutting have also resulted in sedimentation and habitat degradation in the low-gradient areas (FAA 1996). In 1990, King County constructed the Miller Creek detention facility to alleviate some of these impacts (see Figure 1.3-1).

Since 1982, King County Surface Water Management (KCSWM) has monitored flow rates at the outlet of the Miller Creek detention facility (KCSWM 1994). The available flow data provide a good record of base flows, normal wet and dry season flows, and annual peak flows. Streamflow rates are typically highest between October and April and lowest between May and September (FAA 1996). Montgomery Water Group (1995) modeled hydrologic characteristics in the basin and found that in some years no flow occurs in the upper watershed areas during portions of the summer (i.e., 1 in 10-year low flow). They also reported that summer flows are 0.5 cfs less than about 10 percent of the time. Flows during the dry season and wet season are shown in Table 5.1-3. Table 5.1-4 summarizes data for flood frequency estimates in Miller Creek at the Miller Creek detention facility.

**Table 5.1-3. Estimated base flow rates at the Miller Creek detention facility outlet structure.**

| Season                  | Flow Rate (cfs) |
|-------------------------|-----------------|
| Dry (May – September)   | 0.5             |
| Wet (October – April)   | 5.0             |
| Approximate Annual Peak | 40.0            |

Source: KCSWM (1994)

**Table 5.1-4. Flood frequency estimates for Miller Creek at the Miller Creek detention facility control structure.**

| Return Period (years) | Peak Flow Rate (cfs) |
|-----------------------|----------------------|
| 1.01                  | 21                   |
| 1.11                  | 40                   |
| 2                     | 75                   |
| 10                    | 125                  |
| 20                    | 141                  |
| 50                    | 161                  |
| 100                   | 175                  |

Source: Montgomery Water Group (1995)

### Existing Fish Habitat

Historically, Miller Creek supported anadromous fish runs of coho salmon, chum salmon, and sea-run cutthroat trout, as well as resident populations of pumpkinseed sunfish (*Lepomis gibbosus*), sculpin, and cutthroat trout (FAA 1996). A qualitative electrofishing survey conducted in August 1996 identified cutthroat trout, pumpkinseed sunfish, and three-spine stickleback in reaches between South 160<sup>th</sup> Street and the outlet of Lake Reba (Aquatic Resource Consultants 1996). One coho smolt was captured downstream of the culvert under South 160<sup>th</sup> Street during a 1996 electrofishing survey. In addition, three cutthroat trout were found north of a natural waterfall above South 160<sup>th</sup> Street during another electroshocking study on November 10, 1998 by Parametrix, Inc.

The stream currently supports a small coho salmon run maintained by annual releases of hatchery-reared fingerlings raised by the Des Moines Section of Trout Unlimited (FAA 1996; Hillman et al. 1999). No spawning activity was observed during surveys conducted in 1996 by WDFW. However, the Des Moines Section of Trout Unlimited reported 91 coho spawners in a recent survey. The Port has prepared a Biological Assessment that evaluates the effect of the Master Plan Update improvement projects on fish species recently listed under the ESA (Parametrix 2000c).

Residential development in the watershed has resulted in a general deterioration of fish habitat due to removal of native riparian vegetation, stream channelization and bank armoring, filling of riparian wetlands, reduction of the availability of LWD, and increased runoff rates and non-point source pollution loading. Expansion of impervious surface area in the basin has caused increased volumes and velocities of stormwater runoff (resulting in increased bank erosion) and downcutting. These factors have contributed to a general lack of (1) instream cover, (2) available low- and high-flow habitat or refuge, (3) available spawning habitat in the basin, (4) habitat complexity, and (5) high-quality water (KCSWM 1987; and FAA 1996).

Natural, unaltered stream reaches in the Miller Creek basin are essentially nonexistent, while major portions of the main stem and associated drainage ditches are channelized or otherwise modified (KCSWM 1987). The portion of the stream crossing the Vacca Farm site has been channelized, lacks woody debris, and provides limited habitat complexity. This reach is dominated by low-velocity flows and excessive sedimentation, which appears to be partially caused by agricultural runoff. FAA (1996) estimated that 10 tons of sediment are transported to the stream annually from approximately 11 acres of adjacent agricultural land. These factors contribute to the lack of pools, and therefore a lack of refugia (resting places) for fish during high-flow events.

Several natural and man-made barriers appear to limit fish access to the upper basin; however, they are not barriers under all flow conditions. The most prominent barrier on Miller Creek is a natural 8-ft-high waterfall about 0.2 mile upstream of South 160<sup>th</sup> Street that restricts upstream fish passage. Several corrugated metal and concrete box culverts, such as a culvert located at South 160<sup>th</sup> Street, appear to be barriers under certain flow conditions.

These barriers, combined with habitat availability, likely contribute to the current fish distributions in Miller Creek; salmonids occupy primarily downstream reaches while other species occur upstream. Recent studies (FAA 1996; Hillman et al. 1999) have found that suitable coho salmon spawning habitat and evidence of coho salmon spawning are limited to the area downstream of First Avenue South, while suitable cutthroat trout spawning habitat is scattered in small patches between South 156<sup>th</sup> Way and First Avenue South. Areas upstream of First Avenue South consist

predominantly of a fine silt and sand substrate, which is more suitable habitat for the non-salmonid fish species that occur there.

### **Existing Riparian Vegetation**

Downstream of the Miller Creek detention facility, about 200 linear ft of the stream is bordered by small tree and shrub riparian vegetation. Riparian vegetation consists of stands of red alder saplings (*Alnus rubra*) with an understory of hardhack (*Spiraea douglasii*), Himalayan blackberry (*Rubus discolor*), and field horsetail (*Equisetum arvense*).

Throughout most of the Vacca Farm site, riparian vegetation associated with Miller Creek is typically a narrow band less than 50 ft wide. Riparian vegetation is dominated by reed canarygrass (*Phalaris arundinacea*), climbing nightshade (*Solanum dulcamara*), and introduced grass species. Scattered throughout this area are black cottonwood (*Populus trichocarpa*) and willow (*Salix* spp.) trees and saplings. This narrow band of low-quality riparian vegetation separates the stream from the adjacent cultivated farmland.

#### **5.1.1.3 Ownership**

Property at the Vacca Farm site and along Lora Lake needed for the stream relocation has been purchased by the Port as part of the larger property acquisition program for the proposed Master Plan Update improvements.

#### **5.1.1.4 Rationale for Selection**

The Miller Creek relocation mitigation provides the opportunity to restore both high-quality stream habitat and floodplain wetland habitat that will result in on-site, in-kind replacement for stream and wetland functions impacted by the Master Plan Update projects. The existing portion of Miller Creek that will be relocated was moved from its original location within the floodplain at the Vacca Farm site to increase the amount of floodplain suitable for farming. The original channel was moved to the east, straightened, and dredged to facilitate drainage and increase agricultural land on the site. As a result, although the channel still floods, it lacks the connection with its floodplain and floodplain wetlands that it historically had. The channel does not meander across the floodplain and there are no side channels, sloughs, or backwater areas. The existing channel lacks complexity (e.g., straight uniform channel bed, no undercut banks, no side channels, no pool/riffle morphology, uniform silty substrate), there are few instream habitat features (e.g., no LWD, no pools or backwater areas), and the riparian vegetation provides little shade or organic matter to the channel.

Relocation and restoration of channel morphology therefore provides the opportunity to restore both aquatic habitat and floodplain wetland functions on the site. The mitigation plan for the channel relocation will restore channel morphology and instream habitat. In addition, the connection between channel and floodplain wetlands will be restored to the extent possible, while avoiding the creation of new hazard wildlife attractants near the airport. Integration of channel and floodplain will be designed to allow the channel to flood periodically, but to avoid standing water in floodplain wetlands.

### 5.1.1.5 Constraints

Relocation of Miller Creek must occur on-site in proximity to the existing channel. The Vacca Farm site is nearly level, with only a few feet of grade change from north to south. The alignment for the new channel has been designed to facilitate meeting design criteria for flow and velocity given the existing site topography. Meeting these criteria requires that the stream relocation reach be as short as possible to ensure that the maximum channel slope is maintained. The length of the relocated stream reach cannot be increased and still meet the minimum gradient for required flow velocities and depth. As a consequence of constraints on channel length, the new channel will remain fairly close to the re-aligned roadway and the embankment. The buffer width between the relocated stream and South 154<sup>th</sup> Street is constrained by the maximum length of the new stream channel (Figure 5.1-1). Constraints on the channel design are described in detail in Section 5.1.1.6, Channel Relocation Mitigation Design.

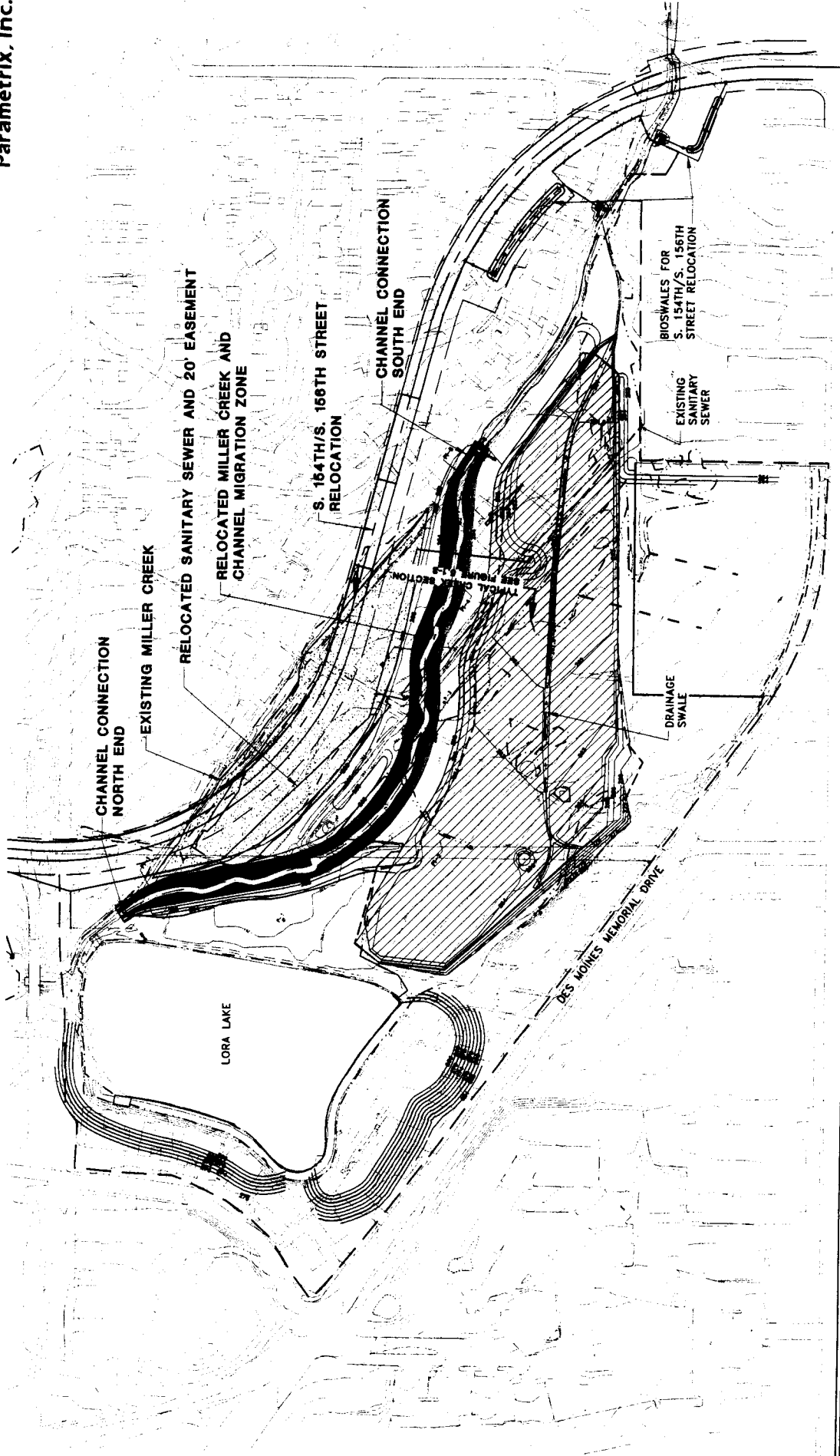
No other apparent constraints outside of the Port's control could affect the success of the stream relocation. No plans exist to change the Miller Creek detention facility's operation procedure. Stormwater management is now planned to occur in new facilities (i.e., vaults and/or ponds located in upland areas) that are independent of the Miller Creek detention facility (for details, refer to the *Comprehensive Stormwater Management Plan*, Parametrix 2000a, 2001a). However, even if the existing detention facility were enlarged to provide more flood storage, this would not be expected to change flow rates in Miller Creek. The detention facility could be enlarged to provide greater stormwater storage without increasing the maximum elevation of water storage or peak discharge rates. This could be accomplished by excavating uplands that are located south of the facility to an elevation within the operating range of the facility to provide new storage. This will not affect the mitigation design because stream hydrology, specifically base flow and normal seasonal flow, will not be significantly modified, and it is unlikely that peak flows will be increased.

### 5.1.1.6 Channel Relocation Mitigation Design

The goals of the design are focused on the need for the relocated channel to continue to convey base flows, maintain sufficient depths during summer low-flow periods for fish passage, prevent deposition of fines and scouring to maintain fish habitat, and allow flood flows greater than annual peak flows to overtop the channel banks and flow onto the floodplain.

#### Channel Design

The channel design process evaluated and adjusted design variables and constraints (e.g., channel depth, width, flow velocity, channel slope, etc.) to meet the design goals and criteria. The critical variables in new channel design are channel slope, flow velocities (i.e., dry and wet season base flows, annual peak flows, and flood flows above annual peak flows), maximum design flow, channel depth and bottom width, channel roughness, and channel length. Initial channel slope was determined using the available drop in elevation along the new reach. The corresponding channel bottom width was determined and adjusted until the minimum flow depth (0.25 ft) was achieved. The slope was then adjusted until the base flow velocity was high enough to move sediment particles smaller than sand to reduce siltation and fining of the bed (Figure 5.1-2). Using the adjusted slope, the channel was then designed to convey peak flows (in connection with maximum depths and channel configurations described in the following sections). Channel widths and flow depth were then adjusted to assure that peak flow velocities were less than the transport velocity for gravel.



0 80' 160'  
SCALE IN FEET

DATE: 11/18/20

LEGEND

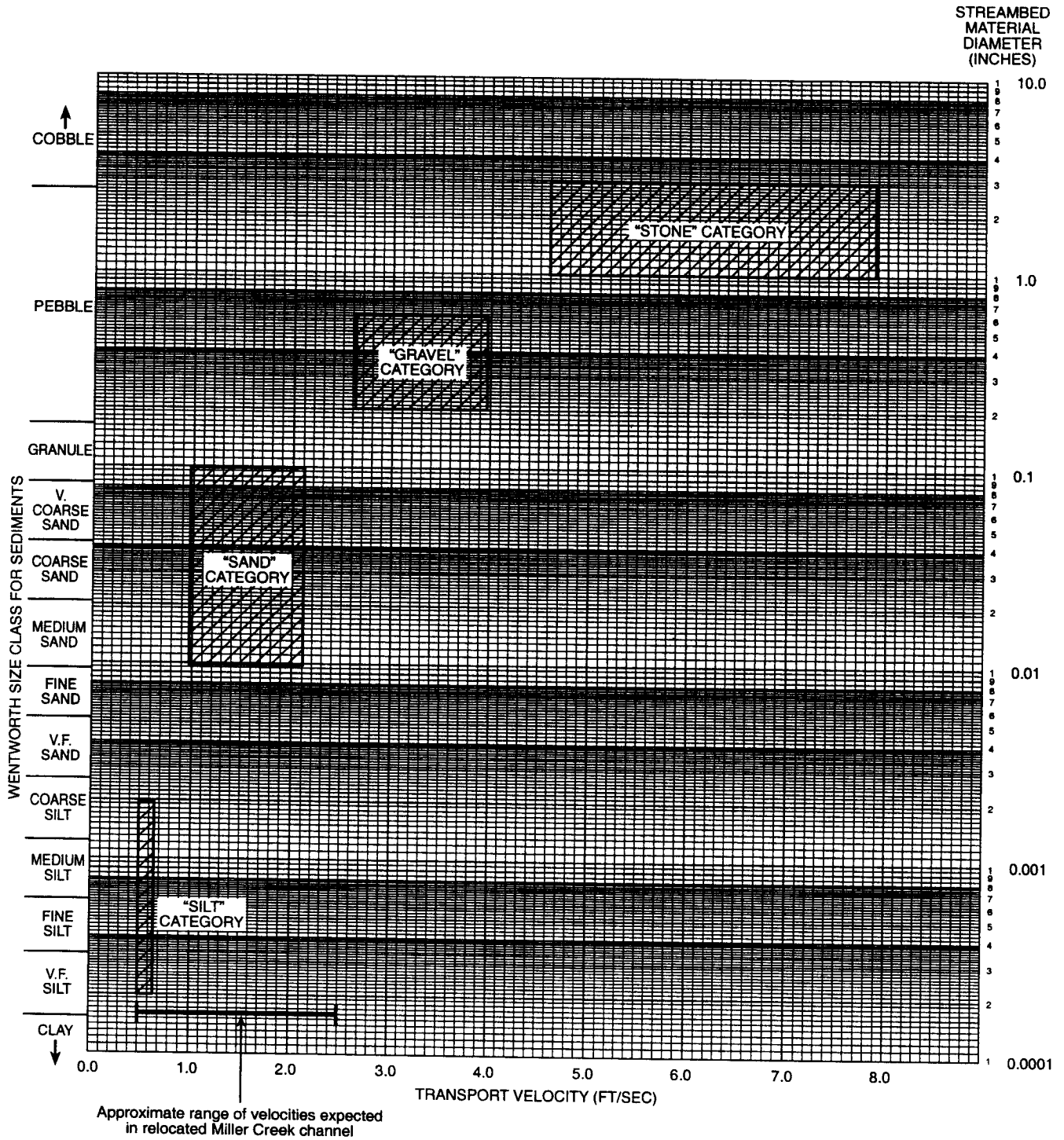
- RELOCATED SANITARY SEWER
- EXISTING SANITARY SEWER
- WETLAND BOUNDARY
- EXISTING CONTOUR

- PROPOSED CONTOUR
- LIMIT OF CONSTRUCTION
- FILLED FLOODPLAIN  
8,465 CY (5.24 AC.-FT.)

- WETLAND (VERIFIED)
- PROPOSED FLOODPLAIN EXCAVATION  
9,569 CY (5.94 AC.-FT.)
- ROAD RIGHT OF WAY

Figure 5.1-1  
Vacca Farm Wetland Restoration  
Grading Plan

AR 049138



Source: Fisheries and Oceans (1980)

Port of Seattle/Natural Resource Mitigation Plan/556-2912-001/01(03) 12/00 (K)

**Figure 5.1-2  
Sediment Transport Velocity  
vs. Sediment Diameter**

AR 049139

The channel design (Figure 5.1-3 and Sheets C5 and C8 of Appendix A) includes a geotextile fabric liner for the relocated segment of Miller Creek. The geotextile will facilitate constructability of the channel in the peat soils, allowing placement of channel substrates other features with out excessive mixing with the underlying peat soils.

The proposed geotextile fabric is highly permeable, and is designed to permit groundwater exchange<sup>21</sup>. Because the geotextile fabric will be permeable, the stream will be hydrologically connected to the high groundwater table that is typically present in the underlying peat soils.<sup>22</sup> The high water table that is present on the site, the elevation of the new stream channel at or below the elevation of the groundwater, and the relative low permeability of the peat compared to the channel substrate will assure that the creek flows are maintained at the surface and not lost to groundwater.

Particles of the underlying peat soils and overlying stream substrate are expected to mix within the geotextile fabric. Thus, over time the permeability of the liner will match that of the adjacent strata. Particles from the underlying peat soils (typically under hydrostatic pressure) would be most likely to migrate into the liner and thus, the liner's permeability would eventually be expected to match or exceed the permeability of the peat soils.

The material specifications for spawning gravel (see below) is suitable for cutthroat trout and includes some fine sands and silts. These finer particles will reduce the permeability of the substrate such that during low flow periods the stream flow will remain as surface flow, and not flow laterally through the channel substrate. The lack of significant substantial clay sized particles in the spawning gravel mix will allow water to move from the underlying peat, through the geotextile liner, and into the stream bed materials.

Spawning gravels for the stream channel are specified to be naturally occurring, granular material. They will not be not crushed or fractured, and must be free of roots, wood, organic material, and any other deleterious substances. They must meet the following size gradation:

| Sieve Size | Percent Passing | Sieve Size   | Percent Passing |
|------------|-----------------|--------------|-----------------|
| 4" square  | 100             | ¼" square    | 25-50           |
| 2" square  | 80-100          | U.S. No. 4   | 20-40           |
| 1" square  | 80-100          | U.S. No. 10  | 10-20           |
| ¾" square  | 70-90           | U.S. No. 100 | 5-10            |
| ½" square  | 50-70           | U.S. No. 200 | 5 max.          |

<sup>21</sup> Geotextile liners are by definition permeable, unless identified as "impermeable geomembrane liner". The geotextile liner's permeability of 60 to 110 gallons per minute per square foot is much greater than that of the underlying peat.

<sup>22</sup> This design approach represents an improvement over the existing condition, as the existing stream channel consists of a ditch excavated in inorganic soils that are peripheral to the peat. Groundwater that currently surfaces in the peat flows through an agricultural ditch before entering the stream at the extreme south end of the site. The new design allows groundwater to discharge to the stream channel itself throughout the mitigation site.



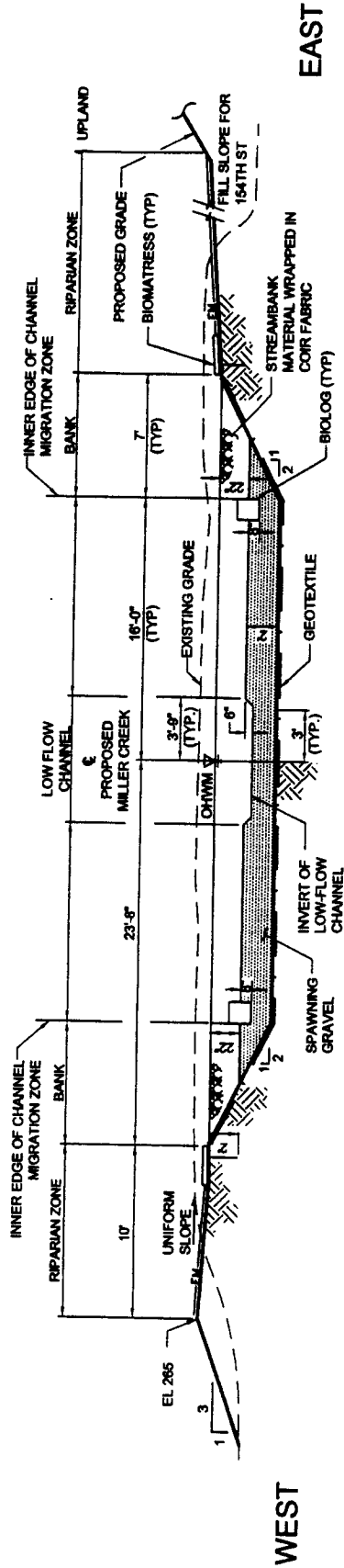


Figure 5.1-3  
Channel Cross Section  
Miller Creek Location

AR 049141

FILE: 291203\_FS.1-1  
DATE: 09/24/01

SCALE: HORIZONTAL 1"=10'  
VERTICAL 1"=10'

**Hydrology**

The hydrologic design criteria for the Miller Creek relocated channel design are listed in Table 5.1-2. Design criteria for determining base flow, annual peak flow, and 100 year flow conditions were established from data gathered by KCSWM. These flow rates were determined from data gathered at the outlet of the Miller Creek detention facility (which includes Lake Reba), which is several hundred feet upstream of the mitigation site. Data have been gathered at this location since 1988 (KCSWM 1994). These flow data provide a good record of normal base flows, seasonal peak flows, average flows by season, and extreme flows during near-record events. Design criteria for base flow and annual peak flow conditions were established from these data (Table 5.1-5). Statistical analysis of the flow monitoring data was not conducted.

**Table 5.1-5. Estimated flow rates for Miller Creek channel design.**

| <b>Flow Regime</b>   | <b>Flow Rate (cfs)</b> |
|----------------------|------------------------|
| Dry season base flow | 0.5                    |
| Wet season base flow | 5                      |
| Stormflow            | 10                     |
| Annual peak flow     | 40                     |
| 2-year peak flow     | 75                     |
| 10-year peak flow    | 125                    |
| 100-year peak flow   | 175                    |

Source: Montgomery Water Group (1995), with additional data compiled by Parametrix.

In addition to monitored flow rate data, a detailed hydrologic modeling study was prepared (Montgomery Water Group 1995) that calculated peak flow rates for flood frequencies up to the 100-year flood (Table 5.1-6). The flood return frequencies were calculated assuming that the Miller Creek detention facility and control structure are in place. The calculated flow rates appear to be consistent with the flow monitoring data. The peak monitored flow rate (225 cfs) on November 24, 1990 was in excess of the current predicted 100-year flood flow. The control structure was constructed after the 1990 storm; it is likely that the peak flow rate of November 1990 would have been reduced by the detention system. Because stormwater runoff will be mitigated in separate stormwater management facilities, this plan does not increase channel capacity for increased flows.

**Table 5.1-6. Flood frequency estimates for Miller Creek at the Miller Creek detention facility control structure.**

| <b>Return Period (years)</b> | <b>Peak Flow Rate (cfs)</b> |
|------------------------------|-----------------------------|
| 1.01                         | 21                          |
| 1.11                         | 40                          |
| 2                            | 75                          |
| 10                           | 125                         |
| 20                           | 141                         |
| 50                           | 161                         |
| 100                          | 175                         |

Source: Montgomery Water Group (1995).

### **Stream Hydraulics**

Stream hydraulics are the existing or proposed physical conditions that influence the direction, depth, and flow velocity in the proposed relocated stream. Several factors influence hydraulics, including flow rates, channel slope, channel cross section, channel roughness, and flow depth. While several of these features will be designed, factors such as flow rate or average channel slope cannot be modified. The following sections discuss the design parameters that apply to all channel segments, and the proposed channel configuration for each segment.

### **Flow Velocity**

Channel flow velocity is the primary variable influencing channel design and fish habitat. The low-flow goal is to minimize fine-grained (sands and finer) material sedimentation in the proposed channel during normal dry season base flows. Conversely, the flow velocity at peak flows must not exceed rates that would erode the channel banks or scour loose substrate larger than small gravel.

The relationship between flow velocity and sediment transport velocity is shown in Figure 5.1-2. If the flow velocity equals or exceeds that shown for each grain size, the sediment can be expected to move until the velocity decreases. If the maximum velocity of a specific section of a stream channel is known, an estimate of the size of the bed material that would be relatively stable can be determined. These relationships are used to determine the size of stream substrate materials and their long-term stability. The Miller Creek channel design thus balances a minimum base flow velocity designed to prevent sedimentation with a maximum peak flow velocity designed to prevent scouring. Using Figure 5.1-2, the channel parameters were adjusted to maintain base flow velocity greater than the silt movement velocity, but less than the gravel movement velocity for peak flow. Preventing gravel movement in the new reach will prevent scouring of the substrate.

### **Channel Slope**

The average channel slope in the relocated reach is determined by physical constraints (i.e., topography) of the Vacca Farm site. The proposed channel drops 2.5 ft in approximately 1,118 ft for an average channel slope of 0.22 percent. The approximate elevation at the point where the relocated stream rejoins the existing channel is 260.0 ft. However, the natural land slope along the proposed stream channel does not drop continuously. Due to the small vertical drop over the relocated segment, a relatively uniform grade is proposed for Miller Creek.

### **Channel Flow Depth**

Given the goals for fish habitat, desired substrate characteristics, and stream hydrology, flow depth standards have been determined. These flow standards are: (1) a dry season water depth of at least 0.25 ft; (2) a wet season water depth of 1 ft; (3) a maximum depth of 2 ft at the mean annual flow rate, and (4) flows greater than the annual maximum flow rate (40 cfs) will overflow the streambanks, flooding the Vacca Farm site.

### **Maximum Design Channel Flow**

The topography and available channel slope in the project area limit constructing a large channel that can convey the 100-year storm while maintaining a minimum flow depth for dry season base flows. Therefore, the channel will overflow onto the floodplain at flows greater than approximately 40 cfs. The floodplain and floodway are designed to convey the 100-year flows of 175 cfs.

### **Channel Bottom Width**

The relocated channel bottom width is largely controlled by the minimum low-flow depth of 0.25 ft. During the dry season, the water depth must average at least 0.25 ft to provide minimum depth for fish movement. To determine the channel bottom width, the base flow rate, slope, roughness, and side slopes were fixed, and the bottom width was adjusted until the flow depth was at least 0.25 ft. The results were checked to ensure that no other design criteria were changed to exceed design parameters. Results indicate that a channel bottom width ranging from 4 to 10 ft meets the design criteria for minimum flow depth. Thus, a low-flow channel between 4 and 10 ft wide will maintain a minimum flow depth of 0.25 ft during summer low flows to allow fish passage while conveying wet season base flows (see Figure 5.1-3).

### **Channel Roughness and Side Slopes**

Channel roughness, described by using Manning's roughness factor ( $n$ ), is a key factor in determining channel capacity. The Manning's channel roughness factor for a natural stream channel with a gravel or stony bottom and limited instream vegetation is 0.0035. This factor was used for calculating channel capacity for the relocated reach. The Miller Creek relocated channel will consist of a high-flow (or bench area) and a low-flow channel. The low-flow channel will have an 18- to 24-inch-deep gravel streambed, and will be generally 4 to 10 ft wide by 6 inches deep. It will meander within the 32-ft-wide high-flow channel, forming a channel migration zone (see Figure 5.1-3). The low-flow channel is designed to convey base flows and to overtop its banks approximately once a year during annual peak flows (i.e., between approximately 20 and 40 cfs). The annual peak flows will be accommodated within the 32-ft high-flow channel. Flood flows greater than the annual peak flows (i.e., greater than 40 cfs) will overflow the streambanks onto the floodplain.

The new channel is located in an area with peat soils; however, the channel will not be constructed directly in peat soils without bank stabilization (see Figure 5.1-3). The streambanks will be constructed using blended soils and gravels wrapped in an erosion control fabric. The toe of the channel banks will be protected by installing prefabricated logs made of dense coconut fibers wrapped in erosion control fabric. This construction method provides immediate erosion protection as well as a rooting substrate that will facilitate revegetation of the banks. The area adjacent to the channel banks will be sloped toward the channel at 2 to 10 percent grade for positive drainage.

The side slopes of the low-flow channel will be 1:1, which is required to maintain minimum flow depths of 0.25 ft for fish passage. This design will also allow some minor undercutting of channel banks over time to increase shelter for fish. Low-flow channels of natural streams in the Puget Sound region typically have vertical side slopes (Rosgen 1994; Montgomery and Buffington 1993), and the design thus mimics natural stream channels. The side slopes of the new channel will be stabilized with bioengineering and by planting native vegetation (i.e., primarily willow stakes). The low channel gradient and design of the low-flow channel to overflow into the larger channel during storms greatly decrease the likelihood of erosive flows.

### **Channel Alignment**

The channel will be constructed to meander within the limits of the stream corridor as shown in plan and cross section in Figures 5.1-1 and 5.1-3. The extent of meandering is limited by the need to maintain a minimum channel slope to meet flow velocity goals.

### **Sewer Line Relocation**

Relocation of Miller Creek (design and construction) will be coordinated with realignment of the sewer line required by relocation of South 154<sup>th</sup> Street. The sewer line will parallel the new road alignment (outside of the mitigation site boundary) and will cross under the new channel (see Figure 5.1-1). The sewer line will be approximately 4 ft below the invert of the new channel. The trench in which the sewer line lies will be backfilled with compacted fill material that will provide a stable surface over the sewer line. The Port has analyzed the need for additional stabilization below the new channel to protect the sewer line and the channel. This analysis indicates that because of the depth of the sewer line, the flat topography of the site, and the small size of the channel, no extra measures will be required to stabilize the channel over the sewer line. The new channel will be located in a portion of the Miller Creek floodplain that is more or less flat; stream velocities are low in this portion of the stream, and there is no potential for significant downcutting within the new channel reach. During periods of high flows, the channel is designed to overtop its banks and flow onto the floodplain, which further reduces any potential for downcutting.

The 20-ft easement for the relocated sewer will be located outside of the mitigation site boundaries, except where the line crosses under the stream. A maintenance access road will be located within the easement along the east side of the mitigation site; however, the access road will not go through the mitigation site (Appendix A, Sheet C2).

### **Wildlife Considerations**

Design and implementation of mitigation for STIA must meet flight safety issues and FAA requirements. Collisions between birds and aircraft are a serious safety issue. Open-water areas, wetlands, and tall trees can create an aviation hazard by attracting waterfowl, small flocking birds (such as European starlings), and raptors. Fish can also attract birds, such as raptors or herons, that pose hazards to aviation. When these habitat features are within 10,000 ft of airport runways, the potential for collisions with aircraft can be serious. For these reasons, mitigation projects within 10,000 ft of STIA runways are designed, where feasible, to reduce existing wildlife hazards and avoid creating new hazards. At the Vacca Farm area, hazardous wildlife currently use the site and are periodically controlled. Wildlife use of the mitigation site will be monitored and managed according to the WHMP (USDA 2000).

Fish habitat design standards for Miller Creek were developed based on the habitat requirements of cutthroat trout.<sup>23</sup> The planned features include:

- Shading to minimize temperature increases during the summer
- Higher velocity riffles to maintain oxygen levels and reduce sedimentation

---

<sup>23</sup> While coho salmon may find suitable rearing habitat in this area, flow conditions are not anticipated to be suitable for spawning coho.

- Placement of logs, rocks, or other structures to provide refuge
- Shading of the channel with native vegetation

Channel shading will enhance the stream habitat and also decrease the stream's visibility to birds of prey (e.g., herons, raptors) that would use the stream to collect food. Riparian vegetation will thus help reduce potential wildlife hazards along the channel. The following sections describe how the stream design will meet cutthroat trout habitat criteria and FAA requirements for aviation safety.

### **Instream Habitat**

The instream habitat criteria used in the relocated channel design are based on general habitat requirements of the resident salmonid cutthroat trout and coho salmon, which could potentially use the site. Although anadromous salmonids have not been observed in the proposed impact areas, resident cutthroat trout are present. These criteria are used to provide the highest quality fish habitat possible. Designing the relocated stream to meet habitat requirements of salmonids helps ensure that the best possible fish habitat is created.

In general, salmonids require cool, well-oxygenated water; spawning gravel that is free of accumulated silt; and abundant instream cover for habitat. In addition, because habitat requirements vary as life stages change, habitat complexity within the stream is also necessary. General physical habitat requirements include access to critical habitat features, stable flows, appropriate stream substrate, and riparian and instream cover.

Salmonids require cover provided by such features as undercut banks, logs, boulders, deep pools, and overhanging riparian vegetation for feeding, hiding, and resting. In addition, these features help stabilize streambanks and substrate during high-flow periods. The relocated channel, which is designed with vertical banks in the low-flow depth range, will encourage minor undercutting to provide cover during low-flow periods. LWD (e.g., deflector logs, angle logs, and root wads) and boulders will be used to stabilize the substrate, protect the upper banks from excessive erosion, and provide hiding and holding habitat for fish during higher flow periods (Figure 5.1-4).

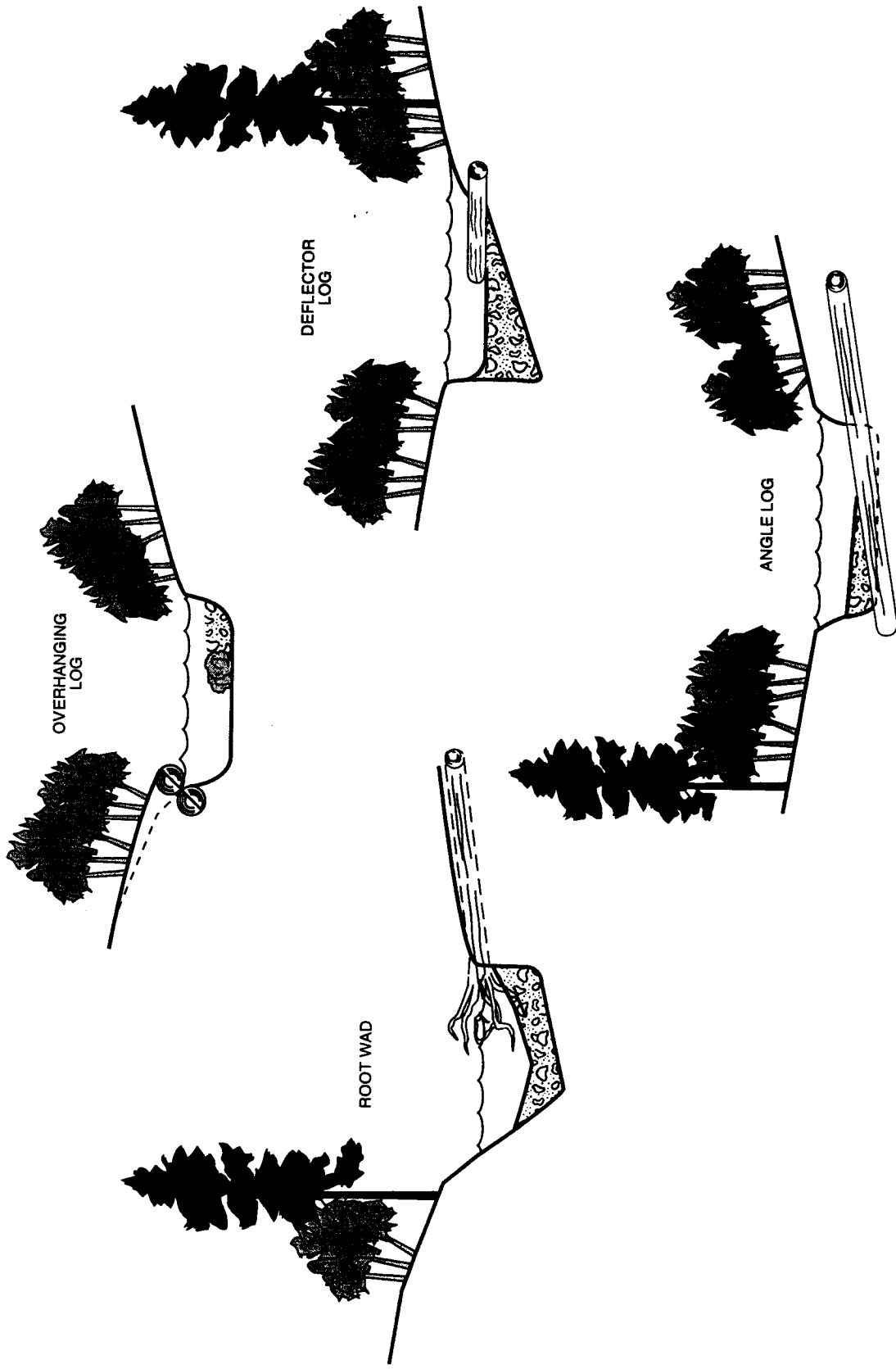
### **Fish Access**

Adequate fish access throughout the entire relocated stream section will be provided by the minimum design depth requirements (i.e., 0.25 ft during dry season base flows). Accessible habitat includes protected areas (i.e., low-velocity pockets) during high flows. The channel is also designed to avoid habitat features that could cause stranding problems during low-flow conditions.

This minimum depth requirement should allow fish access to habitat throughout the length of the channel, thus limiting stranding problems during low-flow periods.

### **Stable Flow**

Stable flows ensure habitat access and protect the habitat against erosion or scouring; they also minimize fish displacement to less preferred habitats. The channel width and bank slope criteria incorporated in the design will help maintain relatively stable flow velocities throughout the range of flows expected in the new channel.



Data Compiled by Parametrix

Port of Seattle/Natural Resource Mitigation Plan 7556-2912-001/01(03) 12/00 (K)

**Figure 5.1-4  
Representative Fish Habitat  
Enhancement Features**

### **Stream Substrate**

Cutthroat trout require stable gravel and sand substrates largely free of accumulated silt for spawning and during early rearing life stages. This also contributes to the optimum production of desired prey. Substrate in the relocated channel will consist of primarily of gravel, coarse sands, and cobble material substrate (see specifications provided earlier) to provide stable spawning and rearing habitat. However, portions of the channel will naturally accumulate sand over time. The flow velocity criteria for the channel were set to maintain suitable substrate for fish by minimizing the accumulation of fine-grained material in the channel during low-flow periods and preventing excessive scouring of the substrate during high flows. Since flow velocities are not constant along the entire channel, sedimentation is expected to occur on the inside of bends and in deeper pools during low-flow periods. However, these sediments will flush out during higher flows.

### **Floodplain Conveyance**

The 100-year floodplain elevation and floodway delineation in the proposed project area were determined by FEMA when the Flood Insurance Rate Maps (FIRM) were prepared. The proposed channel capacity was checked to assure it could convey the 100-year peak flow. Since the floodplain storage capacity on the Vacca Farm site does not decrease (see Section 5.1.2), no increase in future conveyance capacity of the channel is necessary. During flood events, the stream would overtop the channel banks and flood the existing and regraded floodplain. The floodplain itself is broad and nearly level, and it has adequate storage and conveyance capacity to prevent increases in the 100-year flood elevation upstream of the site.

### **Channel Planting and Riparian Buffer**

The new channel banks will be stabilized and cover will be provided to the stream by planting the banks with native willows. Shade cloth will be used to provide shade over the channel during the summer months until 40 percent cover of riparian vegetation is reached. Use of shade cloth (between Stations 2+00 and 13+00 [see Appendix A]) will ameliorate stream temperatures while riparian vegetation is becoming established. A forested buffer will also be planted along the stream riparian zone to maximize stream shade and provide overhanging cover as habitat. These planting plans are described in Section 5.1.2.7. Upland trees and shrubs will also be planted on the roadway slope east of the new channel. These plantings will buffer the stream from the road, but no mitigation credit will be sought for this area (Appendix A, Sheet C1.1).

#### **5.1.1.7 Implementation**

Construction of the third runway, which requires the relocation of Miller Creek, is currently scheduled as part of the first phase of the proposed Master Plan Update implementation. Channel relocation construction is currently anticipated to begin the first construction season (i.e., summer) following granting of the permits for the project. After the new channel is complete, Miller Creek will be diverted and monitoring will begin. Instream work associated with new channel construction must occur during low-flow periods and be consistent with HPA permit conditions as specified by WDFW. Construction of the channel relocation will be coordinated with construction of the third runway, South 154<sup>th</sup> Street/South 156<sup>th</sup> Way relocation, the sewer line relocation, and construction of Vacca Farm floodplain projects. A detailed description of implementation, construction methods, and construction steps for the Vacca Farm projects, including the stream relocation, is included in Section 5.1.4.



### **5.1.1.8 Monitoring and Performance Standards**

The Miller Creek relocation project will be monitored consistent with the approach and schedule outlined in Section 4 of this document. Detailed performance standards and contingency measures for the Miller Creek channel are included in Table 5.1-7, which summarizes performance standards and monitoring methods and parameters for all of the Vacca Farm mitigation projects. The general monitoring schedule for the Vacca Farm projects is provided in Table 5.1-8. Monitoring the new channel includes routine inspections and emergency inspections following major floods.

#### **Hydrology and Hydraulics**

The effectiveness of the relocated stream will be evaluated in several ways. Because erosion and sedimentation are the primary indicators of stream hydraulic conditions, they are the critical criteria to be included in the proposed monitoring plan. The following activities will be included in the stream monitoring plan to determine whether specific performance standards are being met (see Tables 5.1-7 and 5.1-8):

- Inspect the constructed habitat features (log weirs, root wads, etc.) to ensure they have not been damaged or displaced (to the extent that they are not providing habitat)
- Inspect the substrate to ensure that sedimentation and erosion prevention goals are met
- Inspect for erosion or scouring
- Evaluate substrate material to determine if particle sizes remain stable, and there is no evidence of excessive siltation or scouring
- Inspect stream structures and channel after major storms, as monitored by the KCSWM gage
- Inspect for adverse flooding impacts and ponding water

Fencing along the perimeter of the mitigation area will protect the area from public access and illegal dumping. Where feasible from security and wildlife management concerns, it will be designed to promote wildlife movements. Permanent signs that clearly designate the area as a protected wetland mitigation site will also mark site perimeters. Signs will be inspected regularly and maintained in good condition by the Port.

#### **Channel Bank and Riparian Buffer**

Vegetation along the new channel will be monitored to ensure that channel and riparian plantings meet design goals and become successfully established along the relocated stream. Performance standards, variables to be evaluated (e.g., survival, cover), and specific contingency measures for riparian vegetation are included in Table 5.1-7.

The landscape shows that the planting of conifer trees is phased (see landscape design sheets in Appendix A). It is anticipated that these conifers would be planted in a second planting phase coincident with replacement plantings that may be required to meet the year three performance standard for plant survival. At this time, the conifer species would be planted. The trees will be positioned such that they receive some shade from adjacent plants (trees, shrubs, and groundcover). For the first growing season following this planting, soil moisture conditions will be examined closely, and the use of the temporary irrigation system may be used to reduce mortality and promote growth.

**Table 5.1-7. Final performance standards, evaluation approaches, and contingency measures for mitigation projects at Vacca Farm.**

| Design Criteria                                                                            | Performance Standard                                                                                                                      | Evaluation Approach                                                                                                                                                                                                                                                                                                              | Contingency Measures                                                                                                                                                                                                                                       |
|--------------------------------------------------------------------------------------------|-------------------------------------------------------------------------------------------------------------------------------------------|----------------------------------------------------------------------------------------------------------------------------------------------------------------------------------------------------------------------------------------------------------------------------------------------------------------------------------|------------------------------------------------------------------------------------------------------------------------------------------------------------------------------------------------------------------------------------------------------------|
| <b>I. Relocation of Miller Creek (relocated portion of stream (1080 ft) on Vacca Farm)</b> |                                                                                                                                           |                                                                                                                                                                                                                                                                                                                                  |                                                                                                                                                                                                                                                            |
| 1.                                                                                         | The channel cross section will provide an average dry season base flow velocity that is greater than the transport velocity (0.7 ft/sec). | Average flow velocities will exceed 0.7 ft/sec at flows of 0.5 cfs or greater. Measurements of stream velocity.                                                                                                                                                                                                                  | Alter velocities in low-flow channel using woody debris or boulders.<br>Narrow portions of channel using LWD, boulders, or gravel bars to increase velocity.                                                                                               |
| 2.                                                                                         | Design a natural channel with stable gravel bottom in riffle sections suitable for spawning of cutthroat trout.                           | Substrates will contain less than 20% fine sediments (i.e., sand or smaller) in riffle sections. Riffle areas will be delineated as part of the as built plans. A volumetric assessment of substrate (using McNeil cores or bulk samples) will be performed to document substrate conditions.                                    | If fine sediments are present, evaluate sources; if sources are on Port property, implement stabilization measures to control or eliminate fine sediments.<br>Alter velocities in low-flow channel using woody debris or boulders to adjust channel width. |
| 3.                                                                                         | Channel flow velocity is less than the gravel movement velocity (4 ft/sec) at the 100-year flow (175 cfs).                                | Bed material size will not change compared to record conditions. A volumetric assessment of substrate (using McNeil cores or bulk samples) will be used to document substrate conditions. Channel surveys will be performed to evaluate the presence of scouring or erosion.                                                     | Adjust width of channel, replace spawning gravels, and/or repair any eroded channel banks with bioengineering or additional streambank plantings.                                                                                                          |
| 4.                                                                                         | Flows greater than the annual peak flow will overtop the channel and inundate the adjacent floodplain restoration.                        | Flows greater than the annual peak (40 cfs) will overtop the stream channel and floodplain and relate to streamflow and as built topography (e.g., floodplain elevation and berm height). Measure water elevations in the channel and relate to streamflow and as built topography (e.g., floodplain elevation and berm height). | Adjust bank height, channel morphology, or roughness to alter amounts of overbank flow.<br>Regrade channel banks if necessary.                                                                                                                             |
| 5.                                                                                         | Provide instream habitat features such as deflectors and overhanging logs as needed to maximize available habitat.                        | A minimum of 20 instream habitat features (e.g., LWD, deflectors, logs, root wads) will be present during monitoring years 3, 8, and 15. (LWD is woody material greater than 10 cm in diameter and 2 m in length (Cederholm et al. 1997). Measure abundance, sizes, and location of LWD in the new channel.                      | If losses of LWD occur, evaluate factors contributing to reduction in LWD (e.g., high flows) and address.<br>Add LWD to channel as necessary.                                                                                                              |

**Table 5.1-7. Final performance standards, evaluation approaches, and contingency measures for mitigation projects at Vacca Farm (continued).**

| Design Criteria                                                                                                                                             | Performance Standard                                                                                                                                                                                                                                                                                                                                                                                                                                                                               | Evaluation Approach                                                                                                                                                                | Contingency Measures                                                                                                                                                                                                                           |
|-------------------------------------------------------------------------------------------------------------------------------------------------------------|----------------------------------------------------------------------------------------------------------------------------------------------------------------------------------------------------------------------------------------------------------------------------------------------------------------------------------------------------------------------------------------------------------------------------------------------------------------------------------------------------|------------------------------------------------------------------------------------------------------------------------------------------------------------------------------------|------------------------------------------------------------------------------------------------------------------------------------------------------------------------------------------------------------------------------------------------|
| 6. Provide approximately 3.0 acres of vegetated buffer on the east side of the channel. Establish native vegetation along riparian zone of the new channel. | Establish 3.0 acres of native shrub/forested riparian zone and upland buffers with an average tree density of at least 280 stems/acre and shrub density of at least 2,100 individuals per acre in monitoring years 3, 8, and 15.                                                                                                                                                                                                                                                                   | Vegetation sampling (plots, transects, or plotless techniques) to measure stem density, plant cover, count live and dead plants, and measure cover of non-native invasive species. | Install additional plants if necessary. Identify substitute native species that are adapted to site conditions.<br>Eliminate or reduce the abundance of non-native invasive species.<br>Install protective collars to reduce herbivore damage. |
| 7. Densely plant woody vegetation along the new channel to cover open water and reduce use of the area by waterfowl.                                        | At Year 1, survival of planted stock will be 100%. Average survival of planted trees and shrubs in the first 3 monitoring years shall be at least 80%; cover of native species will be 80% by year 15 <sup>b</sup> .<br>Cover of non-native invasive <sup>c</sup> species will be no greater than 10% during any monitoring year.<br>In monitoring years 3, 8, and 15, the numbers of plant species in the mitigation area shall not decline by more than 10 % from the number originally planted. | Vegetation sampling to determine tree and shrub cover over the portion of the channel below the ordinary high water mark (OHWWM).                                                  | Add additional plants if areas of exposed stream channel are present.                                                                                                                                                                          |

**II. Wetland Enhancement and Restoration on Vacca Farm**

1. Provide approximately 5.94 acre-ft of flood storage to compensate for the Vacca Farm to embankment. The floodplain compensate for area will slope toward drainage approximately 5.24 acre-swales that connect to Miller Natural Resource Mitigation Plan Seattle-Tacoma International Airport Master Plan Update
1. Provide for approximately 5.94 acre-ft of flood storage on acre-ft filled for the Vacca Farm to embankment. The floodplain compensate for area will slope toward drainage approximately 5.24 acre-swales that connect to Miller Natural Resource Mitigation Plan Seattle-Tacoma International Airport Master Plan Update

Record drawings and hydrologic monitoring to verify necessary flood storage is present

Regrade area if not excavated to specifications.

Modify design of swales to improve drainage conditions if necessary.

**Table 5.1-7. Final performance standards, evaluation approaches, and contingency measures for mitigation projects at Vacca Farm (continued).**

| Design Criteria                                                                                                                                                                                                                                                                                  | Performance Standard                                                                                                                                                                                                                                                                                                                                                 | Evaluation Approach                                                                                    | Contingency Measures                                                                                                                                                                                                                                                                                                           |
|--------------------------------------------------------------------------------------------------------------------------------------------------------------------------------------------------------------------------------------------------------------------------------------------------|----------------------------------------------------------------------------------------------------------------------------------------------------------------------------------------------------------------------------------------------------------------------------------------------------------------------------------------------------------------------|--------------------------------------------------------------------------------------------------------|--------------------------------------------------------------------------------------------------------------------------------------------------------------------------------------------------------------------------------------------------------------------------------------------------------------------------------|
| ft filled for the Creek.<br>embankment. Excavate drainage swales to provide positive drainage from the floodplain and prevent standing water during non-flood periods.                                                                                                                           |                                                                                                                                                                                                                                                                                                                                                                      |                                                                                                        |                                                                                                                                                                                                                                                                                                                                |
| 2. Use excavated material from grading the floodplain to create topographic variation in the floodplain.                                                                                                                                                                                         | Topographic features (mounds, ridges) will be constructed at a density of 4 per acre. Dimensions of these features will range between 4 and 8 ft wide; 8 and 16 ft long, and 1 and 2 ft high.                                                                                                                                                                        | Determine density from record survey.                                                                  | Construct additional features if project has not been built to specifications.                                                                                                                                                                                                                                                 |
| 3. Plant native trees, shrubs and herbaceous (see Table 5.1-11, Table 5.1-12) species in these areas at tree densities of greater than 280 trees per acre (trees include willow species) and shrub densities of greater than 2,100 per acre. Intersperse scattered native conifers in this area. | At year 1, survival of planted stock will be 100%. Shrub and tree survival will average at least 80% in the first 3 monitoring years. In monitoring years 3, 8, and 15, at least 280 trees per acre (including willow species) and 2,100 shrubs/acre will remain. Percent cover of native species will be at least 80% by year 15 <sup>o</sup> .                     | Vegetation sampling (plots, transects, or plotless techniques) measure vegetation cover and diversity. | If standards are not met: <ul style="list-style-type: none"> <li>• Select species that are better adapted to existing hydrologic conditions.</li> <li>• Install additional plant material.</li> <li>• Install protective collars to reduce herbivore damage.</li> <li>• Control/reduce non-native invasive species.</li> </ul> |
| 4. Plant the floodplain with native trees, shrubs, herbaceous species will be at                                                                                                                                                                                                                 | Percent cover of native species will be at least 80% by year 15 <sup>o</sup> . In newly planted or enhanced areas, non-native invasive species cover will be no more than 10% in all monitoring years. In monitoring years 3, 8, and 15, the numbers of plant species in the mitigation area shall not decline by more than 10 % from the number originally planted. | Vegetation sampling (plots, transects, or plotless techniques) to estimate canopy                      | See above.                                                                                                                                                                                                                                                                                                                     |

**Table 5.1-7. Final performance standards, evaluation approaches, and contingency measures for mitigation projects at Vacca Farm (continued).**

| Design Criteria                                                                                                                                                                                                                                                          | Performance Standard                                                                                                                                                                                                               | Evaluation Approach                                                                 | Contingency Measures                                                           |
|--------------------------------------------------------------------------------------------------------------------------------------------------------------------------------------------------------------------------------------------------------------------------|------------------------------------------------------------------------------------------------------------------------------------------------------------------------------------------------------------------------------------|-------------------------------------------------------------------------------------|--------------------------------------------------------------------------------|
| and grasses to deter water fowl.                                                                                                                                                                                                                                         | least 80% by year 15 <sup>b</sup> .                                                                                                                                                                                                | cover.                                                                              |                                                                                |
| 5. Enhance existing forested wetland south of Lora Lake with shrubs to provide a diverse understory. Total density of native shrubs will be at least 1,700 individuals per acre.                                                                                         | At Year 1, survival of planted stock will be 100%. Average survival of planted stock will be at least 80% in the first 3 monitoring years. In monitoring years 3, 8, and 15, shrub density will be at least 1,700 shrubs per acre. | See above.                                                                          | See above.                                                                     |
| In areas where wetland is being enhanced, percent cover of non-native invasive <sup>c</sup> species in the understory will be no more than 10% during any monitoring year.                                                                                               |                                                                                                                                                                                                                                    |                                                                                     |                                                                                |
| In years 3, 8, and 15, the number of plant species present will not decrease by more than 10% from the number installed at baseline.                                                                                                                                     |                                                                                                                                                                                                                                    |                                                                                     |                                                                                |
| <b>III. Lora Lake Buffer Enhancement</b>                                                                                                                                                                                                                                 |                                                                                                                                                                                                                                    |                                                                                     |                                                                                |
| 1. Plant buffer and restoration areas with native trees and shrubs. Plant native tree species at densities of greater than 280 per acre (total of at least 168 trees). Plant native shrub species at densities of greater than 2,100 (total of at least 1,260) per acre. | At Year 1 survival of planted stock will be 100%. Average survival of planted stock will be at least 80% in the first 3 monitoring years. During monitoring years 3, 8, and 15, trees will be present in the buffer.               | Vegetation sampling (plots, transects, or plotless techniques), as described above. | Contingency measures for vegetation performance standards are described above. |
| Percent cover of native species will be at least 80% by year 15 <sup>b</sup> .                                                                                                                                                                                           |                                                                                                                                                                                                                                    |                                                                                     |                                                                                |
| In years 3, 8, and 15, plant diversity will not decrease by                                                                                                                                                                                                              |                                                                                                                                                                                                                                    |                                                                                     |                                                                                |

Table 5.1-7. Final performance standards, evaluation approaches, and contingency measures for mitigation projects at Vacca Farm (continued).

| Design Criteria                                                                            | Performance Standard                                                                                                                                                                                                                                                                                                      | Evaluation Approach                                                     | Contingency Measures                                                                                                          |
|--------------------------------------------------------------------------------------------|---------------------------------------------------------------------------------------------------------------------------------------------------------------------------------------------------------------------------------------------------------------------------------------------------------------------------|-------------------------------------------------------------------------|-------------------------------------------------------------------------------------------------------------------------------|
|                                                                                            | more than 10% from the number and type of plants installed at baseline.<br>Non-native invasive species cover will be no more than 10% by year 15 in newly planted or enhanced areas.                                                                                                                                      |                                                                         |                                                                                                                               |
| 2. Restoration areas will meet wetland hydrology criteria                                  | At the upland edge of the restoration area, the minimum criteria for wetland hydrology (see Environmental Laboratory 1987) will be present. In the interior portions of the site, groundwater will be within 12 inches of the soil surface for at least the period of March through May during years of average rainfall. | Groundwater monitoring.                                                 | Evaluate hydrologic monitoring data and determine site grades that provide the desired hydrologic regime.                     |
| 3. Concrete bulkhead will be removed and shoreline graded to a stable slope configuration. | Record drawings and photo documentation verify that the concrete bulkhead has been removed.<br>New shoreline of Lora Lake will have a slope of 3:1 or gentler.                                                                                                                                                            | Record drawings to verify removal and bulkheads and slope of shoreline. | Remove all structures and bulkhead areas to be consistent with design.<br>Re-grade as necessary to be consistent with design. |

- <sup>a</sup> Compliance with this performance standard will be determined from the record drawing, and will generally not require ongoing monitoring.
- <sup>b</sup> See Table 4.3-1 for interim cover targets (i.e., from year 3 to year 15).
- <sup>c</sup> See Table 4.3-2 for list of invasive, non-native species to be monitored and controlled on the mitigation site.
- <sup>d</sup> During the first few growing seasons following establishment of the new channel, shade will be provided over the channel with the use of nursery shade cloth to shade out about 75% of the ambient solar radiation. Interim cover standards for vegetation (i.e., for monitoring years 1 through 14) are provided in Table 4.3-1)
- <sup>e</sup> See Appendix A for design details.
- <sup>f</sup> Normal rainfall will be based on the definition for 'most years' given in the ACOE manual (Environmental Laboratory 1987) (i.e., annual precipitation in a normal year must be the same as or greater than precipitation in 5 years out of 10) or the average precipitation for a time period plus or minus 1 standard deviation of the mean.

**Table 5.1-8. Miller Creek relocation mitigation monitoring methods and schedule.**

| Feature             | Activity                                                           | Duration                                                                                    | Years Following Construction |   |   |   |   |   |   |   |   |   |    |    |    |
|---------------------|--------------------------------------------------------------------|---------------------------------------------------------------------------------------------|------------------------------|---|---|---|---|---|---|---|---|---|----|----|----|
|                     |                                                                    |                                                                                             | 0                            | 1 | 2 | 3 | 4 | 5 | 6 | 7 | 8 | 9 | 10 | 12 | 15 |
| Habitat Structures  | Visual inspection, photodocumentation                              | Annually (May), or after flows in excess of the 2-year peak flow (during the first 3 years) | X                            | X | X | X |   | X |   | X |   |   | X  | X  | X  |
| Channel Morphology  | Measured cross sections, longitudinal profiles, photodocumentation | Annually (May) or after flows in excess of the 2-year peak flow (during the first 3 years)  | X                            | X | X | X |   | X |   | X |   |   | X  | X  | X  |
| Substrate           | Pebble counts                                                      | Semi-annually (February/August)                                                             | X                            | X | X | X |   | X |   | X |   |   | X  | X  | X  |
| Erosion or Scouring | Evaluate materials and scouring                                    | Annually (May) or after flows in excess of the 2-year peak flow (during the first 3 years)  | X                            | X | X | X |   | X |   | X |   |   | X  | X  | X  |
| Adverse Flooding    | Inspect floodplain for ponded water                                | Twice yearly (February/November)                                                            | X                            | X | X | X |   | X |   | X |   |   | X  | X  | X  |
| Channel Plantings   | Vegetation sampling                                                | Semi-annually (May/June & September/October)                                                | X                            | X | X | X |   | X |   | X |   |   | X  | X  | X  |
|                     | Wetland Delineation                                                | Early spring                                                                                |                              |   |   |   |   | X |   |   |   |   | X  |    | X  |

**Instream Habitat**

Instream habitat conditions in the relocated channel section will be described based on a variety of monitoring data collected using standard methods for ecological evaluations of streams. Hydrologic conditions important to habitat that will be described include water depths, velocities, profile, and area of wetted channel. Substrate conditions (size and type) will be evaluated and described by site observations and pebble counts. The amounts and types of LWD in the stream channel will be described, including the special habitat conditions (undercut banks, side channels, and pools) this LWD creates. The influence of riparian vegetation on instream habitat will be described based on surveys of plant cover overhanging the high- and low-flow channels. Methods for collecting and evaluating this information are provided in Table 5.1-8.

**5.1.1.9 Site Protection**

The Port will execute and file restrictive covenants on the mitigation projects at the Vacca Farm site. Copies of restrictive covenants that have been approved by ACOE, Ecology, FAA, and USDA-WSD are included in Appendix G.

#### **5.1.1.10 Maintenance and Contingency Plans**

A key design objective for the stream channel is that it shall function as a natural channel, requiring little or no maintenance. To ensure that this goal is achieved, the monitoring plan and contingencies have been designed to allow the channel to perform within a range of conditions. If the performance standards indicate that the channel is not within this acceptable range, periodic maintenance may be required to change or remove the factors responsible. Specific contingency measures for the channel relocation are included in Table 5.1-7.

The proposed channel configuration has two basic conveyance criteria that need to be maintained to meet performance standards: (1) maintain minimum flow depths and velocity for fish passage, water quality, and sedimentation; and (2) provide flow capacity for peak flows. If there were to be future changes in flow rates in Miller Creek compared to design flows, contingency measures may be required for the project to continue to meet goals and objectives. The Port does not anticipate that contingency measures will be needed due to future changes in flow rates for the following reasons. Flow rates are unlikely to differ from the design flows used to develop this plan because the design flows were derived from detailed data (including a calibrated Hydrologic Simulation Program FORTRAN [HSPF] model), and because of the extensive BMPs developed for the project (see Section 6 and Parametrix 2000a, 2001a). Possible contingency measures that would be implemented in the case of altered flow rates could include:

- Widening the base flow channel to reduce velocities and improve capacity
- Narrowing the base flow channel with logs or boulders to increase base flow depth and velocity
- Widening the flood flow portion of the channel (above 0.5 ft) to improve capacity and reduce velocity
- Adding log weir steps to flatten stream slope, reducing velocity and increasing base flow depth
- Adding a bypass flow channel to convey peak flows past the main channel.

#### **5.1.2 Vacca Farm Floodplain and Wetland Restoration Plan**

To mitigate the loss of floodplain storage (approximately 5.24 acre-ft) and wetland impacts in the Miller Creek basin, the floodplain and wetlands in the Vacca Farm area will be restored (see Table 5.1-1). Restoration of the historic floodplain and wetlands will include providing a minimum of 5.94 acre-ft of flood storage, restoring wetland hydrology, and re-establishing native vegetation in approximately 12 acres of existing cultivated farmland and aquatic habitat of Lora Lake. Replacing non-native vegetation with native plant communities will enhance existing degraded wetlands on the Vacca Farm site. Planting forested upland buffers around the perimeter of the Vacca Farm site (Figure 5.1-5) will further enhance functions in the restored wetlands. Approximately 5 acres of upland buffers will enhance and protect the floodplain wetlands by increasing infiltration and supporting wetland hydrology and stream base flows, removing sediments and nutrients, and providing physical protection and visual screening from adjacent properties. The Vacca Farm mitigation allows significant wetland functional restoration to occur in proximity to, and in the same basin as, project impacts.



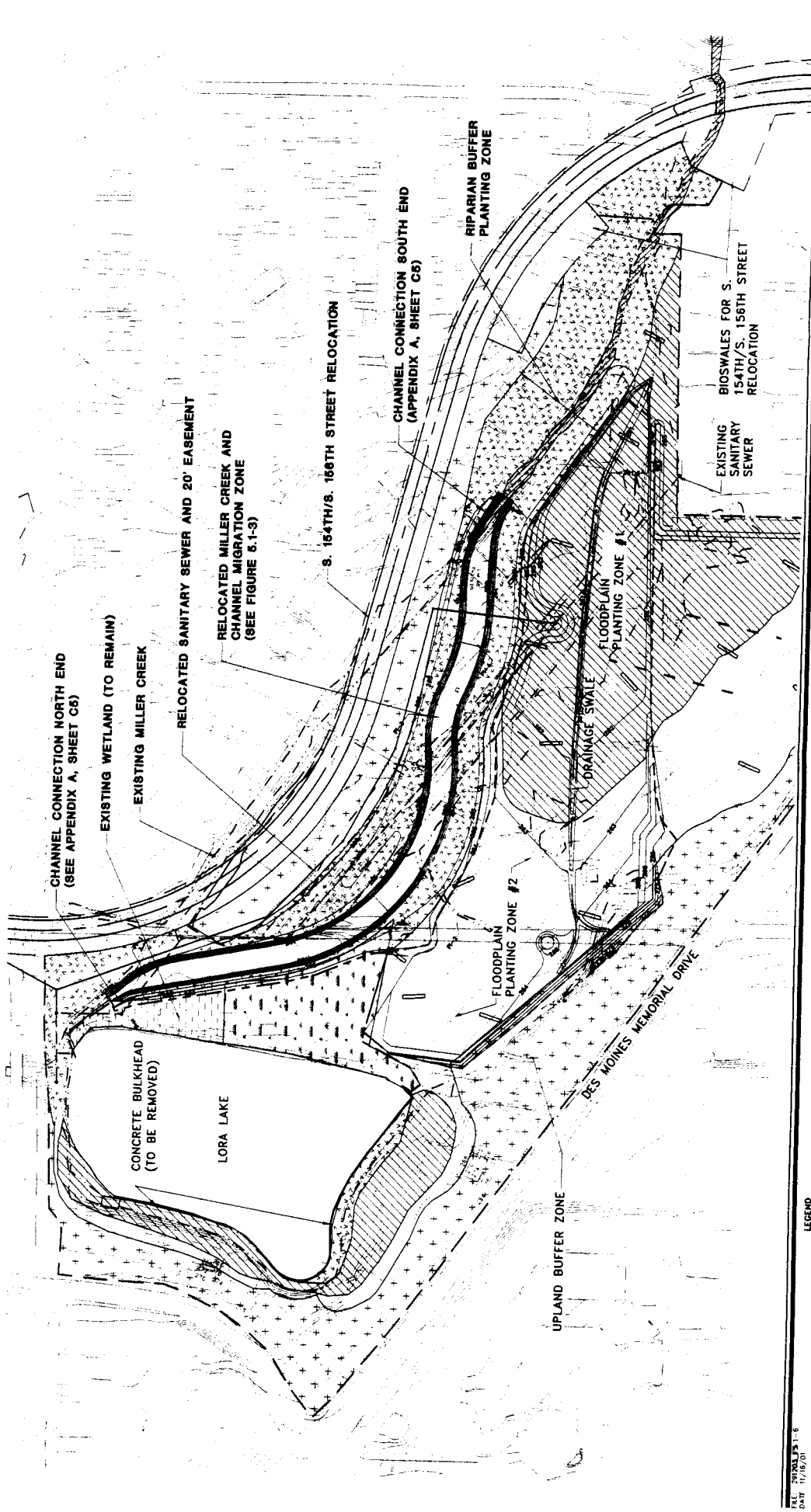


Figure 5.1-5  
Vacca Farm  
Planting Plan

Vacca Farm contains areas which historically were wetland but have altered hydrology due to prior agricultural activities. Historic wetlands north and west of Lora Lake have been filled. The floodplain and wetland restoration will restore wetland hydrology to the site by removing existing drainage features and excavating part of the floodplain to bring seasonal groundwater levels closer to the surface, and removing fill from the perimeter of Lora Lake. Native wetland plant communities will be restored to the floodplain wetlands and existing degraded emergent wetlands will be enhanced to forested or shrub wetlands (see Figure 5.1-5). These actions will enhance hydrologic (i.e., surface water storage) and water quality functions at the Vacca Farm site, as well as reduce the volume of eroded soil, pesticide, and fertilizer runoff reaching Miller Creek.

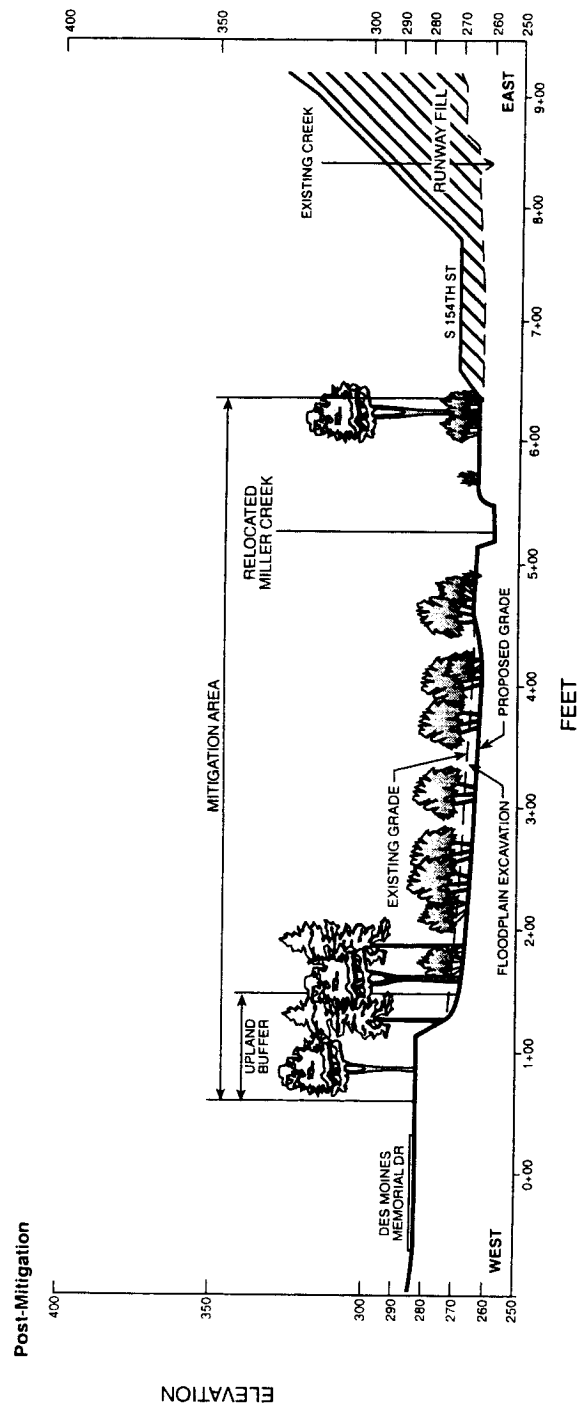
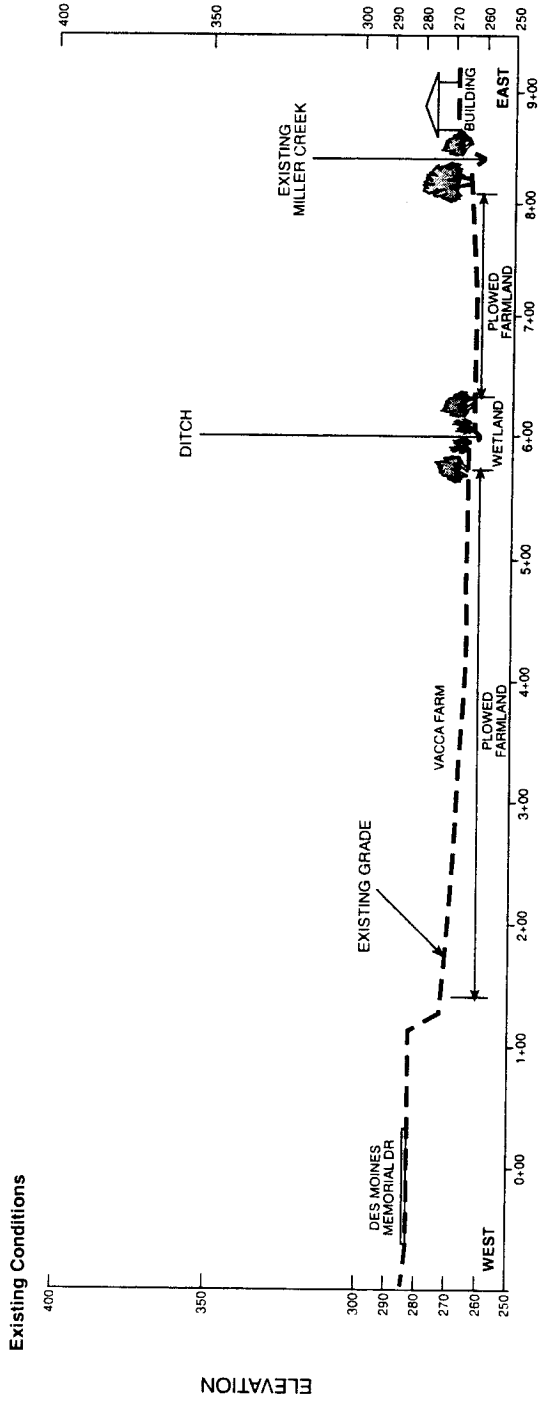
To protect aquatic habitat in Miller Creek and protect and enhance functions of floodplain wetlands, forested buffers will be established and enhanced. An upland buffer area will be established along the east side of the relocated Miller Creek between the riparian zone of the stream and the relocated roadway for South 154<sup>th</sup> Street (Figure 5.1-6, see Figure 5.1-5). The buffer will reduce human intrusion into the riparian zone, screen riparian habitats from human activity, and protect water quality and aquatic habitat. A second upland buffer will be established between the floodplain enhancement area and Des Moines Memorial Drive on the west side of the Vacca Farm site (see Figure 5.1-5). The forested buffer in this area will provide a physical buffer between the road and the enhanced shrub floodplain wetlands and restored stream.

#### **5.1.2.1 Goals, Objectives, and Design Criteria**

Three specific goals have been identified for the Vacca Farm floodplain and wetlands mitigation:

- Compensate for loss of riparian flood storage and wetlands in the Miller Creek basin.
- Restore and enhance floodplain and wetland functions adjacent to Miller Creek in the Vacca Farm site by restoring historic floodplain and wetland hydrology and vegetation. Enhance floodplain, wetland, and stream functions by providing forested riparian and upland buffers.
- Grade the floodplain and create a planting area for the wetland community in the floodplain area that does not attract waterfowl and flocking birds, and reduces existing wildlife hazards.

Specific objectives and design criteria to achieve these wetland mitigation goals are listed in Table 5.1-9.



**Figure 5.1-6  
Typical Cross Section of Miller Creek  
Floodplain Enhancement**

**Table 5.1-9. Mitigation goals, design objectives, and design criteria for the Vacca Farm wetland restoration project.**

| Goals and Design Objectives                                                                                                   | Design Criteria                                                                                                                                                                                                                                                                                                              |
|-------------------------------------------------------------------------------------------------------------------------------|------------------------------------------------------------------------------------------------------------------------------------------------------------------------------------------------------------------------------------------------------------------------------------------------------------------------------|
| <b>Goal 1: Compensate for loss of floodplain and floodwater storage</b>                                                       |                                                                                                                                                                                                                                                                                                                              |
| Provide additional floodplain area by excavating approximately 9,600 cy on the Vacca Farm site.                               | Excavate approximately 9,600 cy of soil between elevation 262 ft and 266 ft.<br><br>Drainage swales to provide positive drainage from the floodplain and prevent standing water during non-flood periods.<br><br>Use excavated material from grading the secondary swales to create topographic variation in the floodplain. |
| <b>Goal 2: Increase functional linkages between historic wetlands and Miller Creek</b>                                        |                                                                                                                                                                                                                                                                                                                              |
| Remove existing agricultural uses from the floodplain area on the Vacca Farm site.                                            | Eliminate farming activities and remove existing structures from restoration site.                                                                                                                                                                                                                                           |
| Restore wetland hydrology to farmed wetlands and prior converted croplands.                                                   | Remove ditches and drains. Grade floodplain to elevations that restore wetland hydrology.                                                                                                                                                                                                                                    |
| Plant floodplain with native trees and shrubs.                                                                                | Restore 11 acres of floodplain (see Table 5.1-1) with native vegetation.<br><br>Plant native shrub species in the floodplain and intersperse native trees in this area. Shrubs will be planted at a density greater than 2,100 per acre.                                                                                     |
| <b>Goal 3: Establish native wetland communities in the mitigation area that does not attract waterfowl and flocking birds</b> |                                                                                                                                                                                                                                                                                                                              |
| Deter flocking waterfowl from using the site.                                                                                 | Plant the floodplain with native trees, shrubs, and tall grasses to deter waterfowl.                                                                                                                                                                                                                                         |

### 5.1.2.2 Mitigation Site Description

The Miller Creek floodplain and wetland restoration project will be located at the Vacca Farm site, northwest of the existing airfield. The Vacca Farm site includes Lora Lake and the area to the south of Lora Lake between the existing Miller Creek channel and Des Moines Memorial Drive (see Figures 2.1-2 and 2.1-4). Vacca Farm contains upland areas around the perimeter of the site; agricultural fields; some scattered farm structures; a system of drainage ditches and tile drains; FWs; and forested, shrub, and emergent wetlands (Parametrix 2000c). A large ditch runs through the middle of the Vacca Farm site, parallel to the existing Miller Creek channel, flowing into Miller Creek at the south end of the site (see Figure 2.1-4).

### 5.1.2.3 Ownership

The Port owns all of the property on the Vacca Farm site.

**AR 049160**

#### **5.1.2.4 Rationale for Selection**

The Vacca Farm site allows significant wetland functional restoration to occur in proximity to, and in the same basin as, project impacts. Mitigation at this site provides the opportunity to restore wetland hydrology and wetland habitat to areas that historically were wetlands, but have altered hydrology due to prior agricultural activities. In addition, because the site has been farmed, non-native plants dominate the site, there are no extensive areas of existing forest or invasive species, and the site is relatively flat. Therefore, minimal grading would be required, and no natural vegetation communities would be disturbed by mitigation activities. The floodplain and wetland restoration will also reduce wildlife hazards near the airport by replacing emergent wetlands with forested and shrub wetlands. These actions will enhance hydrologic (surface water storage) and water quality functions at the Vacca Farm site, as well as reducing the volume of eroded soil, pesticide, and fertilizer runoff reaching Miller Creek.

#### **5.1.2.5 Constraints**

No constraints have been identified that would preclude implementing this plan.

#### **5.1.2.6 Ecological Assessment of the Vacca Farm Mitigation Site**

Ecological conditions important to the mitigation design and implementation are summarized below. Historically the Vacca Farm site likely was a mosaic of forested and shrub wetlands. These wetlands developed on peat soils that formed in a wide floodplain along a low-gradient, frequently flooded reach of Miller Creek. The site currently consists of uplands; agricultural fields; FWs; and forested, shrub, and emergent wetlands.

#### **Miller Creek Floodplain**

The 100-year floodplain in the vicinity of the Vacca Farm is quite extensive (see Figure 2.2-2). The wetland area and poor drainage that existed prior to agricultural drainage activities are evident from the 100-year floodplain estimated by FEMA. The approximate 100-year flood elevations, determined by FEMA as part of its study, vary from 266 ft at the Miller Creek detention facility outlet to approximately 265 ft at the downstream end of the Vacca Farm site. A floodway has also been delineated and mapped in a portion of the floodplain on the Vacca Farm site.

#### **Hydrology**

Wetland hydrology on the Vacca Farm site is supported primarily by high local groundwater levels, and secondarily by precipitation and overbank flooding in Miller Creek. Four groundwater monitoring wells were installed at the Vacca Farm site on May 14, 1997 to evaluate site hydrology. Groundwater levels were then measured during 16 separate site visits between May 30, 1997 and November 12, 1997 (Table 5.1-10). During this period, groundwater levels averaged approximately 1.5 to 2 ft below the ground surface. The largest fluctuation occurred at monitoring well P-1, located in the existing forested and shrub wetland. At this well, the groundwater table was lowest during the dry summer months, and, as expected, higher groundwater levels occurred in the spring and fall. For the past several years (1996 to 2000) during the winter and early spring months, the Vacca Farm site was temporarily flooded and soils were saturated to the surface. These data were

used to estimate hydrologic conditions expected to occur in the floodplain restoration site once drainage ditches are removed and excavation in the floodplain area is complete.

**Table 5.1-10. Groundwater monitoring well data<sup>a</sup> on the Vacca Farm site.**

| Sampling Date | Well Numbers and Surveyed Elevation (ft) <sup>b</sup> |                |                |                |
|---------------|-------------------------------------------------------|----------------|----------------|----------------|
|               | P-1<br>(263.7)                                        | P-2<br>(265.1) | P-3<br>(262.9) | P-4<br>(273.1) |
| 5/30/1997     | -0.9                                                  | -2.0           | -1.3           | -2.5           |
| 6/05/1997     | -0.5                                                  | -1.5           | -0.4           | -2.3           |
| 6/11/1997     | -0.8                                                  | -1.8           | -0.6           | -2.3           |
| 6/19/1997     | -1.0                                                  | -1.9           | -0.7           | -2.4           |
| 7/03/1997     | -                                                     | -2.0           | -0.6           | -2.4           |
| 7/10/1997     | -0.5                                                  | -1.6           | -0.4           | -2.3           |
| 7/25/1997     | -2.0                                                  | -2.2           | -1.3           | -2.5           |
| 7/31/1997     | -                                                     | -2.3           | -1.6           | -2.5           |
| 8/07/1997     | -2.6                                                  | -2.4           | -1.8           | -2.5           |
| 8/14/1997     | -2.7                                                  | -2.6           | -2.1           | -2.5           |
| 9/04/1997     | -                                                     | -2.4           | -1.8           | -2.5           |
| 9/18/1997     | -0.1                                                  | -1.1           | -0.5           | -2.2           |
| 9/26/1997     | -1.0                                                  | -1.7           | -0.5           | -2.3           |
| 10/03/1997    | -0.6                                                  | -1.2           | -0.3           | 2.2            |
| 10/16/1997    | -0.8                                                  | -1.6           | -0.3           | -2.2           |
| 11/12/1997    | -0.5                                                  | -1.4           | -0.2           | -2.2           |

<sup>a</sup> Data are represented as depth to groundwater in ft.

<sup>b</sup> Elevations are represented as ft above mean sea level.

### **Soils**

*The Soil Survey for King County Area Washington* (Snyder et al. 1973) has not mapped soils within the project area. However, Parametrix, Inc. and HWA GeoSciences, Inc. (1998) have evaluated existing soil conditions on the Vacca Farm site. Results of these investigations revealed that most of the soils on the site are underlain by soft, saturated peat that overlies layers of alluvial sands, silts, and dense, glacially deposited material. These conditions indicate that the area was largely a historic wetland that has now been partially drained and highly modified. Typical soil profiles in peat-dominated areas on the Vacca Farm site are shown in Appendix A, Sheet C6.1. Soils in the upland areas on the Vacca Farm site are predominantly silty loams with scattered inclusions of sandy loams.

### **Upland Vegetation**

Upland areas on the Vacca Farm site primarily consist of recently cultivated cropland; no native plant communities are present. Limited areas on the edge of the cultivated fields on the south and

west side of the site are dominated by Scots broom (*Cytisus scoparius*), Himalayan blackberry, Canada thistle (*Cirsium arvense*), and various grass species such as orchardgrass (*Dactylis glomerata*) and common velvetgrass (*Holcus lanatus*).

The upland area in the southern portion of the site contains a gravel fill pad covered with various grass species and a dense Himalayan blackberry thicket. Some of the upland areas surrounding Miller Creek and drainage swales were created from side-cast material from past dredging and maintenance activities in the stream and swales. Cultivated areas have been ditched and drained.

### **Farmed Wetland Vegetation**

Nine farmed wetlands are present on the Vacca Farm site (FWs 1, 2, 3, 5, 6, 8, 9, 10, and 11; see Figure 2.1-4). Farmed wetlands are areas that contain wetland hydrology and soils, but lack wetland vegetation because of farming activities. Additional descriptions of these wetlands can be found in the *Wetland Delineation Report* (Parametrix 2000b). Due to the site's agricultural history, an extensive network of drainage ditches and tile drains exists on the site.

These areas have hydric soils and soil saturation within 12 inches of the soil surface for more than 15 consecutive days during the growing season. It is likely that these areas were wetlands before being converted to active farmland. However, these areas lacked inundation for at least 15 consecutive days during the early growing season and therefore do not meet the criteria for FWs according to the Food Security Act (Section 514.22).

### **Forest, Shrub, and Emergent Wetland Vegetation**

A single large wetland (Wetland A1, approximately 4.66 acres) occurs in the central portion of the Vacca Farm site (see Figure 2.1-4). Wetland A1 is a forested, shrub, and emergent wetland complex located south of Lora Lake and extending south through the center of the Vacca Farm site. The northern portion of this wetland contains red alder and black cottonwood in the tree canopy with willow, hardhack, and common cattail (*Typha latifolia*) in the understory. A narrow band of Wetland A1 continues south and contains scrub-shrub and emergent wetland habitat that bisects the farmed agricultural fields. This wetland area is associated with a large north-south drainage ditch that parallels Miller Creek and ultimately drains into the stream to the south (see Figure 2.1-4). Dominant species in wetlands associated with the ditch include Pacific willow (*Salix lucida*), Himalayan blackberry, common cattail, and reed canarygrass.

Wetlands A2, A3, and A4 are seasonally saturated shrub wetlands located in the center of the Vacca Farm site, in tilled farmland. These wetland islands are dominated by Himalayan blackberry with creeping buttercup (*Ranunculus repens*) around the edges.

#### **5.1.2.7 Vacca Farm Floodplain and Wetland Restoration Design**

This mitigation plan will replace lost flood storage by excavating approximately 9,585 cy of soil that is currently above the 100-year floodplain on the Vacca Farm site. This action will compensate for lost floodplain storage and wetland impacts from construction activities for the third runway fill embankment and portions of relocated South 154<sup>th</sup> Street. The farmed fields at the Vacca Farm site will be regraded to restore wetland hydrology and planted with native tree, shrub, and herbaceous plant species to restore the historic riparian/floodplain wetland. In addition, a portion of an existing

forested, shrub, and emergent wetland (Wetland A1) will be enhanced by planting native shrubs in the area currently dominated by non-native blackberry species. Key elements of the mitigation design are presented below. Specific details on construction sequencing and construction methods for the project are included in the implementation section for Vacca Farm projects (Section 5.1.4).

### **Grading Design**

Prior to grading, existing structures and fences will be removed from the site and existing ditches and drains will be filled or removed to restore site hydrology. The mitigation design objectives for the floodplain grading will be achieved by excavating and grading approximately 6 acres of the Vacca Farm site between elevations 262 and 266. An initial step will be to remove the top 6 inches of topsoil where floodplain grading will occur to remove potential pesticide residues from past farming activities. This soil will be disposed of off-site at an approved upland disposal facility.

To prevent water from accumulating on the new floodplain surface and potentially attracting waterfowl, a drainage swale with secondary side channels will be graded through the middle of the floodplain. The primary channel will be centrally located and approximately 1 to 2 ft wide and 1 to 2 ft deep. Excavation for the channel will add a minor amount of floodstorage capacity to the site, but the channel will not affect the overall functions of the floodplain. During flood events the channel will become inundated by floodwater that backs up as a result of restrictions located downstream (south) of the site.<sup>24</sup> Additional floodwater will enter the site from the north, as the stream overtops its banks. As floodflows abate, and the channel south of the site can accommodate the stream within its channel, the floodplain will drain. The rate of drainage, however, remains controlled by the downstream channel, and not by the on-site drainage channel. The on-site channel simply assures that water is not stored for long periods (i.e., dead storage) on the site.

Side-cast material from creating these channels will be incorporated into the site grading plan to create microtopographic relief. Microtopography will consist of mounds and ridges at a density of approximately 4 features per acre. Depressional areas will not be created due to the potential for attracting hazard wildlife. This microtopographic relief provides habitat complexity that will increase the diversity of plant species that can be supported on the site (Appendix A, Sheet C7.1). LWD will also be added to the floodplain to increase habitat complexity and increase organic matter on the floodplain (Appendix A, Sheet C1.1).

Immediately after grading, the two floodplain wetland planting zones (see Figure 5.1-5) will be hydroseeded with a native grass mix to establish understory plants in these zones. All other areas that have been graded will be hydroseeded with a seed mixture designed to prevent soil erosion and sedimentation to Miller Creek and/or Lora Lake (Table 5.1-11). The seed mixture will stabilize any exposed soils that will not be brought to final grade or permanent vegetation cover within 30 days of exposure. This seed mix should be applied during the period between April 1 through June 30 and September 1 through October 31. If seeding occurs between June 1 and September 30, irrigation may be required to ensure germination and establishment.

---

<sup>24</sup> Because of these downstream restrictions, the floodplain becomes a backwater area, and the drainage channel and the floodplain as a whole is not a floodway or “flow-through” system. The downstream channel restrictions will not be modified, and therefore downstream flow and flood conditions will not change.



**Table 5.1-11. Proposed seed mix for erosion control.**

| Scientific Name                            | Common Name         | Percent by Weight |
|--------------------------------------------|---------------------|-------------------|
| <i>Agrostis alba</i>                       | Redtop              | 10                |
| <i>Lolium multiflorum</i>                  | Annual rye          | 40                |
| <i>Festuca rubra</i> var. <i>commutata</i> | Chewings red fescue | 40                |
| <i>Trifolium repens</i>                    | White clover        | 10                |

All soils left exposed for greater than 48 hours from October 1 through March 31 (or greater than 7 days from April 1 through September 30) will be covered with jute matting or other appropriate BMPs.

As described above, soils at the Vacca Farm site consist primarily of peat and some mineral topsoil. Therefore, it is anticipated that soil amendments will not be necessary after grading activities occur. To the extent practicable, existing organic soils (below the top 6 inches) and sands from the site will be used to create a suitable planting medium and match the proposed final graded surface (Appendix A, Sheet C6). Where use of existing organic soils is not practicable, a prepared topsoil will be tilled into the subgrade prior to planting. Newly graded slopes will be tracked at right angles to the contour to reduce soil erosion.

Temporary irrigation will be installed following grading to provide flexibility in plant installation and to maximize successful establishment, survival, and early growth of hydroseeded cover crops and plant stock. The irrigation system is used to provide suitable wetland hydrology (see below), but to ensure success during the initial critical stages of plant establishment. The system will be designed so that above-ground portions can be removed after a few years, when the option to use irrigation will no longer be needed. Irrigation will use municipal water purchased by the Port. Application rates will be less than agronomic rates, but sufficient to reduce plant mortality and to promote growth during dry periods. Use of the irrigation system is described more fully under Implementation, Section 5.1-4.

### **Expected Hydrology**

The high groundwater table throughout the Vacca Farm site suggests that post-construction hydrology will result in soils that are saturated to the surface from the onset of autumn rains through early summer (early to mid July). Standing water, ranging in depth from 2 to 6 inches, is also expected to occur for short periods during the fall, winter, and spring months. To deter waterfowl from using areas of standing water, dense shrub plantings will be located throughout the site. The upland zones may become saturated during some winter months in years of normal rainfall, but would likely be dry by early summer. Because of a high water table on the site, dewatering may be necessary before grading activities occur (see Implementation, Section 5.1.4).

### **Wildlife Considerations**

Flocking birds, raptors, and waterfowl pose the greatest concern for aircraft safety at STIA. Therefore, a landscape planting approach has been developed to aid in deterring these species from using the new mitigation sites as foraging areas or roost sites. Guidance obtained from Port wildlife

managers and information gathered through literature searches have directed development of the planting plan. For example, Lyon and Caccamise (1981) found that roost stands for European starlings were generally composed of deciduous trees 18 to 35 years of age with stem densities greater than 290 trees per acre (average of about 700 trees per acre). The minimum roost size was 0.32 acre, although the average was about 4.5 acres. Conclusions from this study indicate that these birds typically select roost sites composed of dense stands of young trees that allow the birds to roost in a compact formation, and also provide some thermal protection after leaf fall.

Waterfowl typically prefer to forage in open areas, such as open water, emergent marshes, or mowed lawn, because their view of potential predators is unobstructed. An obstructed view is perceived as dangerous and waterfowl will not typically forage in such an area. Therefore, the planting plan will focus on installing dense shrubs with scattered small trees to obstruct views and landing paths. This strategy will also exclude waterfowl during the winter by creating a dense barrier of stems to cover standing water that is likely to be present.

Geese or waterfowl exclusion measures will likely be necessary during the initial years of the mitigation because the site will be dominated by low vegetation and will be fairly open. Geese exclusion measures will include dense planting of trees and shrubs on the restoration site and the elimination of areas of open, ponded water. During the monitoring period, geese exclusion may also include physical barriers to prevent geese from landing or entering the site.

## **Landscape Plan**

### **Planting Plan**

Six planting zones will be created in the Miller Creek floodplain enhancement and wetland restoration area: Upland Buffers, Existing Wetland Enhancement, Floodplain Zone 1, Floodplain Zone 2, Miller Creek Riparian Buffer, and Miller Creek Channel Planting (see Figure 5.1-5; and Table 5.1-12; Appendix A, Sheets L4 and L5). To minimize wildlife hazards, all the planting plans for the on-site mitigation actions are designed to be unattractive to flocking birds and waterfowl. Plants used in the on-site mitigation areas produce few fruits, berries, or nuts (see Table 5.1-12).

The landscape plan for the area shows that the planting of conifer trees is phased (see landscape design sheets in Appendix A). It is anticipated that these conifers would be planted in a second planting phase coincident with replacement plantings that may be required to meet the year three performance standard for plant survival. At this time, the conifer species would be planted. The trees will be positioned such that they receive some shade from adjacent plants (trees, shrubs, and groundcover). For the first growing season following this planting, soil moisture conditions will be examined closely, and the use of the temporary irrigation system may be used to reduce mortality and promote growth.

### *Upland Buffers*

Upland buffers (see Figures 5.1-5 and 5.1-6; Appendix A, Sheets L4 and L5) are located east and west of the floodplain area, and will be planted with species adapted to seasonally wet, upland soil conditions. Upland buffers will typically be located above the 100-year floodplain (approximately at the 265-ft elevation). The landscape plan for the upland area will focus on planting trees and shrubs in a dense vegetated buffer to protect the floodplain enhancement area from surrounding land uses. Installed tree densities will be at least 280 stems per acre. Trees will be installed according to the

Table 5.1-12. Proposed plant list for mitigation projects in Miller and Des Moines Creek basins.

| Scientific Name                           | Common Name      | Size and Condition <sup>a</sup> | Approximate Spacing (ft/on center) <sup>b</sup> | Upland Zone | Floodplain Zone 1 | Floodplain Zone 2 | Riparian Zone |
|-------------------------------------------|------------------|---------------------------------|-------------------------------------------------|-------------|-------------------|-------------------|---------------|
| <b>Trees</b>                              |                  |                                 |                                                 |             |                   |                   |               |
| <i>Abies grandis</i>                      | Grand Fir        | 3 - 4' B&B                      | 10 to 15                                        | X           |                   |                   |               |
| <i>Acer macrophyllum</i>                  | Bigleaf maple    | 3 - 4' B&B                      | 10 to 15                                        | X           |                   | X                 | X             |
| <i>Alnus rubra</i> <sup>c</sup>           | Red alder        | 3 - 4' B&B                      | 10 to 15                                        | X           |                   |                   | X             |
| <i>Fraxinus latifolia</i>                 | Oregon ash       | 3 - 4' B&B                      | 10 to 15                                        | X           | X                 |                   | X             |
| <i>Picea sitchensis</i> <sup>c</sup>      | Sitka spruce     | 3 - 4' B&B                      | 10 to 15                                        | X           |                   | X                 |               |
| <i>Populus trichocarpa</i>                | Black cottonwood | 3 - 4' B&B/live stake           | 10 to 15                                        |             |                   | X                 | X             |
| <i>Pseudotsuga menziesii</i> <sup>c</sup> | Douglas fir      | 3 - 4' B&B                      | 10 to 15                                        | X           |                   |                   |               |
| <i>Rhamnus purshiana</i>                  | Cascara          | 3 - 4' B&B                      | 10 to 15                                        | X           |                   | X                 | X             |
| <i>Thuja plicata</i>                      | Western redcedar | 3 - 4' B&B                      | 10 to 15                                        | X           |                   | X                 |               |
| <i>Tsuga heterophylla</i>                 | Western Hemlock  | 3 - 4' B&B                      | 10 to 15                                        | X           |                   |                   |               |
| <b>Shrubs</b>                             |                  |                                 |                                                 |             |                   |                   |               |
| <i>Acer circinatum</i>                    | Vine maple       | 2 gal                           | 4 to 6                                          | X           |                   |                   | X             |
| <i>Philadelphus lewisii</i>               | Mock Orange      | 2 gal                           | 4 to 6                                          | X           |                   |                   |               |
| <i>Physocarpus capitatus</i>              | Pacific ninebark | 2 gal                           | 4 to 6                                          |             |                   | X                 | X             |
| <i>Rosa nutkana</i>                       | Nootka rose      | 2 gal                           | 4 to 6                                          | X           |                   |                   |               |
| <i>Rosa pisocarpa</i>                     | Clustered rose   | 2 gal                           | 4 to 6                                          |             |                   | X                 | X             |
| <i>Salix hookeriana</i>                   | Hooker willow    | live stake <sup>d</sup>         | 4 to 5                                          |             | X                 |                   | X             |
| <i>Salix lucida</i>                       | Pacific willow   | live stake <sup>d</sup>         | 4 to 5                                          |             | X                 |                   | X             |
| <i>Salix sitchensis</i>                   | Sitka willow     | live stake <sup>d</sup>         | 4 to 6                                          |             | X                 |                   | X             |
| <i>Salix scouleriana</i>                  | Scouler's willow | live stake <sup>d</sup>         | 4 to 5                                          |             | X                 |                   | X             |
| <i>Spiraea douglasii</i>                  | Hardhack spirea  | 2 gal                           | 4 to 5                                          |             | X                 |                   | X             |
| <b>Grasses</b>                            |                  |                                 |                                                 |             |                   |                   |               |
| <i>Agrostis exarata</i>                   | Spike bentgrass  | Seed                            |                                                 |             |                   | X                 |               |
| <i>Beckmannia syzigachne</i>              | Sloughgrass      | Seed                            |                                                 |             | X                 |                   | X             |

Table 5.1-12. Plant list for mitigation projects in Miller and Des Moines Creek basins (continued).

| Scientific Name                 | Common Name        | Size and Condition <sup>a</sup> | Approximate Spacing (ft/on center) <sup>b</sup> | Upland Zone | Floodplain Zone 1 | Floodplain Zone 2 | Riparian Zone |
|---------------------------------|--------------------|---------------------------------|-------------------------------------------------|-------------|-------------------|-------------------|---------------|
| <i>Calamagrostis canadensis</i> | Canada reed        | Seed                            |                                                 |             | X                 | X                 |               |
| <i>Deschampsia cespitosa</i>    | Tufted hairgrass   | Seed                            |                                                 |             | X                 | X                 |               |
| <b>Sedges and Rushes</b>        |                    |                                 |                                                 |             |                   |                   |               |
| <i>Carex amplifolia</i>         | Ample-leafed sedge | Seed                            |                                                 |             | X                 | X                 |               |
| <i>Carex praticola</i>          | Meadow sedge       | Seed                            |                                                 |             | X                 |                   |               |
| <i>Carex stipata</i>            | Sawbeaked sedge    | Seed                            |                                                 |             | X                 | X                 |               |
| <i>Scirpus cyperinus</i>        | Wool-grass         | Seed                            |                                                 |             | X                 | X                 |               |
| <b>Herbaceous</b>               |                    |                                 |                                                 |             |                   |                   |               |
| <i>Aster subspicatus</i>        | Douglas aster      | Seed                            |                                                 |             |                   | X                 | X             |
| <i>Solidago canadensis</i>      | Canada goldenrod   | Seed                            |                                                 |             |                   | X                 |               |

<sup>a</sup> Depending on availability and season, plant condition may be substituted. B&B refers to ball and burlap.  
<sup>b</sup> All shrub plantings for the Miller Creek floodplain wetland restoration, Miller Creek drainage channel replacement, and Tye Valley Golf Course will be planted 3 to 4 ft on center  
<sup>c</sup> These species will not be a dominant component of the planting plan in order to limit the potential to attract flocking birds.  
<sup>d</sup> Live stake material will typically be used in the Miller Creek relocation buffer planting and in other buffer/floodplain plans, where appropriate. Spacings for line stakes may range from 18 inches to 3 ft on center.

planting plan and field locations will approved by the landscape architect or wetland biologist. Installed shrub densities will be greater than 2,100 individuals per acre (see Table 5.1-7). The planting scheme in the upland areas will place coniferous and deciduous tree species in patches to create a broken canopy.

#### *Existing Wetlands to be Enhanced*

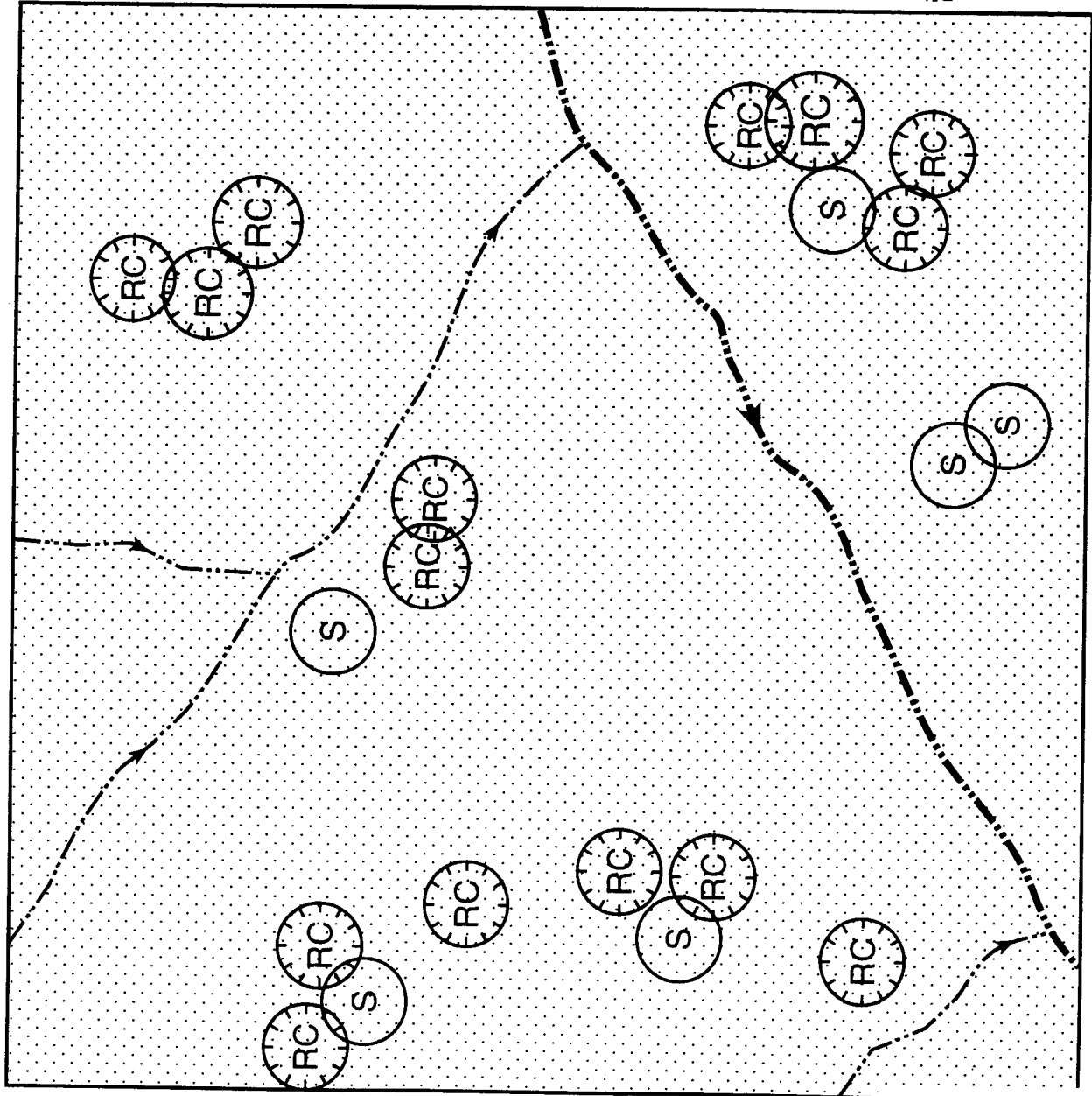
Removing non-native invasive species in selected areas and infill planting with native tree and shrub species will enhance existing wetlands on the Vacca Farm site. A portion of Wetland A1, south of Lora Lake, contains an area that historically has been disturbed by agricultural and other activities. As a result of this disturbance, non-native invasive species such as Himalayan blackberry have become dominant in this portion of the wetland. Therefore, an enhancement plan has been developed for this area to promote a native wetland vegetation community. Patches of blackberry will be removed and the wetland will be planted with native small tree and shrub species (primarily willows) to create a native shrub/tree community and to reduce cover of non-native species. Planting densities for infill tree planting will be greater than 250 stems per acre and for shrub planting will be greater than 1,700 individuals per acre. Infill planting densities are slightly lower than planting densities in cleared and/or graded areas because some native vegetation already exists in areas to be infill planted.






#### *Floodplain Wetlands (Planting Zone 1 and Planting Zone 2)*

Floodplain wetlands will be restored to native small tree and shrub wetland plant communities following grading. The landscape plan for the wetland floodplain restoration area will be similar to that described above with regard to wildlife attractants. Shrubs will be planted in dense patches to provide continuous shrub cover, with western redcedar (*Thuja plicata*) and some deciduous trees on microtopographic high points interspersed in the shrub planting (Figure 5.1-7). Floodplain Zone 1 is the wettest zone on the floodplain and will be planted with species tolerant of the prolonged saturation and periods of inundation that will occur below elevation 262.5 ft. Floodplain Zone 2 will be slightly drier than Zone 1 and will consist of wetland plant species tolerant of the wet and saturated soil conditions that occur between elevations 262.5 and 265 ft. Figure 5.1-6 and Sheet C1.2 in Appendix A show a typical cross section of the Vacca Farm floodplain following grading and planting. Figure

Installed tree densities will be at least 280 stems per acre. Trees will be installed according to the planting plan and field locations will approved by the landscape architect or wetland biologist. Installed shrub densities will be greater than 2,100 individuals per acre.

Herbaceous understory species will be established in the two floodplain wetland zones by hydroseeding a native grass/sedge/forb mix in these zones in early fall, following grading (see Table 5.1-11). The hydroseed mix will contain seeds and a wood fiber mulch and tackifier to stabilize soils and enhance germination. Plant species included in the mix are designed to provide for rapidly germinating species that can provide initial cover, as well as later germinating species that will add to the cover and species diversity of the herbaceous vegetation of the floodplain communities.



-  Sitka Spruce
-  Western Redcedar
-  Mixed Shrub
-  Drainage Swale
-  Secondary Drainage Swales

Note: See Appendix A Sheets L1 and L2 for details

Port of Seattle/Natural Resource Mitigation Plan/556-2912-001/01(03), 12/00 (K)

**Figure 5.1-7**  
**Typical Planting Plan for the**  
**Miller Creek Floodplain, Zone 2**

### *Miller Creek Riparian Buffer and Channel Planting*

In addition to the upland buffers along the northwest and east sides of the site, riparian buffers will be established along Miller Creek and around Lora Lake (see Figure 5.1-5; Appendix A, Sheets L4 and L5). Species proposed to be planted in the riparian buffer include black cottonwood, Pacific willow, Sitka willow (*Salix sitchensis*), Scouler's willow (*Salix scouleriana*), bigleaf maple (*Acer macrophyllum*), Oregon ash (*Fraxinus latifolia*), red alder, Pacific ninebark (*Phsocarpus capitatus*), and vine maple (*Acer circinatum*). An average 50-ft buffer will be established on both sides of the relocated segment of Miller Creek, although in some areas the buffer will be less than 50 ft wide due to the location of the embankment and South 154<sup>th</sup> Street/South 156<sup>th</sup> Way. The immediate channel banks of the newly relocated channel will be planted with live willow stakes (Appendix A, Sheets L4 and L5). A typical cross section of the proposed buffer area around Miller Creek appears in Figure 5.1-6 and in Appendix A, Sheet C1.2.

#### **Planting Approach**

Planting will occur whenever possible in late fall (October to November) or early spring (March or April), when soil moisture and plant conditions are optimal for installing plants. However, it may not always be possible or desirable to plant only during the winter months. For example, soils could be frozen or too wet at times during the winter months, limiting the amount of planting that can take place. Irrigation will be installed on the site to make it possible to plant during times of the year other than winter or early spring. Trees of varying heights (between approximately 36 and 48 inches) will be planted to provide height diversity, and trees and shrubs will be planted in a mosaic of species and heights to simulate natural patchiness. Trees and shrubs will be planted at densities (see Table 5.1-12) sufficient to attain the performance standards in Table 5.1-7. A landscape architect or wetland scientist will be on-site to observe placement and installation of the plant material to ensure that plants are installed according to the planting plan and specifications.

To reduce potential competition with non-native species, mulch or landscape fabric will be placed around the base of trees and shrubs. Girdling or other damage from small or large mammal grazing will be reduced or prevented through the use of collars, or the stems of installed plant material may be painted with a mixture of pruning wax and a natural deterrent such as cayenne pepper.

#### **5.1.2.8 Monitoring and Performance Standards**

The Vacca Farm floodplain and wetland mitigation site will be monitored consistent with the approach and schedules outlined in Section 4 of this document. Specific performance standards and contingency measures for the Vacca Farm floodplain are included in Table 5.1-7. The general monitoring schedule for the Vacca Farm projects is provided in Table 5.1-8. Monitoring objectives specific to the Vacca Farm site are designed to evaluate the functioning of the relocated channel (discussed above in Section 5.1.1.8), floodplain hydrology, wetland indicators, and the establishment of the upland and wetland plant communities (Table 5.1-13). Monitoring for hazard wildlife will also be conducted at the Vacca Farm site, as described in Section 4.

### **Floodplain Hydrology**

Floodplain groundwater hydrology will be monitored at the Vacca Farm site for at least a 15-year period following completion of all mitigation construction. The primary purpose of monitoring groundwater levels is to verify that shallow groundwater continues to support wetland hydrology on the site, and that seasonal groundwater levels are sufficient to support the wetland plant communities on the site. Groundwater hydrology will be monitored at the Vacca Farm site consistent with the methods and approach outlined in Section 4 of this document.

### **Vegetation Monitoring**

Vegetation will be monitored in all planting zones at the Vacca Farm site to verify that performance standards are being met, and to develop contingency measures as necessary (see Table 5.1-7, Table 5.1-13). Vegetation monitoring will be consistent with the approach, methods, and schedules provided in Section 4 of this document.

#### **5.1.2.9 Site Protection**

The Port will execute and file a restrictive covenant for the mitigation area. Copies of proposed restrictive covenants are included in Appendix G.

The boundaries of the mitigation area and buffers shall be permanently marked with stakes at least every 100 feet or with fencing. The marking shall include signage that clearly indicates that mowing and fertilizer/pesticide applications are prohibited within mitigation areas. The details of fencing and signage are provided in Appendix P.



**Table 5.1-13. Monitoring schedule for wetland restoration and floodplain enhancement at Vacca Farm.**

| Feature                                               | Activity                                                          | Timing                                                  | Data Collection Year |   |   |   |   |   |   |   |   |   |    |    |    |   |   |   |   |   |
|-------------------------------------------------------|-------------------------------------------------------------------|---------------------------------------------------------|----------------------|---|---|---|---|---|---|---|---|---|----|----|----|---|---|---|---|---|
|                                                       |                                                                   |                                                         | 0                    | 1 | 2 | 3 | 4 | 5 | 6 | 7 | 8 | 9 | 10 | 12 | 15 |   |   |   |   |   |
| Floodplain Storage                                    | A topographic survey of the site.                                 | Immediately after grading is complete                   | X                    |   |   |   |   |   |   |   |   |   |    |    |    |   |   |   |   |   |
| Hydrology                                             | Measure the maximum depth and approximate duration of inundation. | Monthly                                                 | X                    | X | X | X |   |   |   |   |   |   |    |    |    |   |   |   |   |   |
|                                                       |                                                                   | Once during winter, late spring/early summer, and fall  |                      |   |   | X | X | X | X | X | X | X | X  | X  | X  | X | X | X | X | X |
|                                                       | Measure depth to groundwater.                                     | Monthly                                                 | X                    | X | X | X |   |   |   |   |   |   |    |    |    |   |   |   |   |   |
|                                                       |                                                                   | Once during winter, late spring/early summer, and fall  |                      |   |   | X | X | X | X | X | X | X | X  | X  | X  | X | X | X | X | X |
| Establishment of Vegetation                           | Calculate percent plant survival.                                 | Once late spring to early summer                        | X                    | X | X | X |   |   |   |   |   |   |    |    |    |   |   |   |   |   |
| Achieve an early successional wetland plant community | Vegetation mapping.                                               | Once in late spring to early summer                     | X                    | X | X | X |   |   |   |   |   |   |    |    |    |   |   |   |   |   |
|                                                       |                                                                   | Once in late spring to early summer in year 3, 5, 7, 10 |                      |   |   | X | X | X | X | X | X | X | X  | X  | X  | X | X | X | X | X |
| Reports                                               | Photographic documentation and walk-through survey.               | Once in spring                                          | X                    | X | X | X |   |   |   |   |   |   |    |    |    |   |   |   |   |   |
|                                                       |                                                                   | Wetland delineation                                     |                      |   |   |   |   |   |   |   |   |   |    |    |    |   |   |   |   |   |
|                                                       |                                                                   | Early spring                                            |                      |   |   |   |   |   |   |   |   |   |    |    |    |   |   |   |   |   |
|                                                       |                                                                   |                                                         | X                    | X | X | X |   |   |   |   |   |   |    |    |    |   |   |   |   |   |
|                                                       |                                                                   |                                                         |                      |   |   |   |   |   |   |   |   |   |    |    |    |   |   |   |   |   |
|                                                       |                                                                   |                                                         |                      |   |   |   |   |   |   |   |   |   |    |    |    |   |   |   |   |   |

### 5.1.2.10 Maintenance and Contingency Plans

Routine maintenance tasks (e.g., maintaining irrigation systems, removing trash, mulching, mowing) and adaptive management contingency measures (e.g., re-planting, weed control) will be implemented consistent with the approach outlined in Section 4. If the Vacca Farm site does not meet performance standards during the monitoring period, contingency measures will be implemented using the adaptive management approach outlined in Section 4. Specific contingency measures are provided for each performance standard in Table 5.1-7.

Meeting the performance standards for non-native invasive species at Vacca Farm will likely require implementation of contingency measures during the 15-year monitoring period. Potential invasive species of concern at the Vacca Farm site include, but are not limited to, reed canarygrass, Himalayan blackberry, Japanese knotweed (*Polygonum cuspidatum*, and *P. sachalinense*), and purple loosestrife (*Lythrum salicaria*). These species are a concern because they already occur at Vacca Farm and may be difficult to eliminate, or because propagules of these plants are likely to continuously re-invade the site from upstream aquatic sources or from the surrounding area. Successfully establishing native vegetation on the site will be a key component in reducing and controlling invasive species in the long term at the mitigation site. In the short term (i.e., during the 15-year monitoring period), contingency measures specified in Table 5.1-7 will be implemented as necessary to control invasive species on the site.

Possible contingency measures that may be implemented to reduce hazard wildlife attractants specific to Vacca Farm are included in Table 5.1-7. Contingencies include eliminating areas of standing water on the floodplain by planting shrubs or minor regrading to eliminate depressions. Measures to control wildlife hazards will be consistent with the Port's WHMP approach described in Section 4.

Examples of the types of contingency actions that may need to be implemented at Vacca Farm include:

- If topographic surveys reveal inadequate floodplain storage capacity, additional grading will be undertaken to replace the lost floodplain area.
- If standing water persists on the site for extended periods such that waterfowl use of the site is regular, then corrective actions will be taken to plant densely with shrubs or create positive flow of surface water off the site to Miller Creek.
- If invasive species cover is greater than specified in the performance standards, or if native plant survival is reduced by competition with non-native invasive species, then invasive species removal and/or control will be implemented.
- Replacement plants will be installed if survival is less than 80 percent in the first 3 years.
- If plant species exhibit greater than 20 percent mortality within the first 3 years, site conditions would be re-evaluated to determine whether the conditions could support the species. If the site cannot support the original plant species, then those species may be replaced with species of similar form and function and tolerance to hydrologic conditions on the site.

### 5.1.3 Lora Lake Shoreline Enhancement

Mitigation at Lora Lake includes removing a concrete bulkhead, removing residential structures, and removing wetland fill from the west and north perimeters of the lake. These disturbed areas will be planted with wetland shrub communities. A forested buffer will be planted around the lake (Figure 5.1-8; Appendix A, Sheet C3.2) (see Table 5.1-1).

Replacing concrete bulkheads with a vegetated shoreline and establishing forested buffers around Lora Lake provide the opportunity to enhance water quality and habitat in the lake. Restored wetlands and buffers around Lora Lake will also enhance the aquatic habitat functions of the lake and the overall function of the restored wetlands in the Vacca Farm floodplain. In particular, the buffer restored wetlands, and bulkhead removal will increase the amount of organic detritus source to the lake for the benefit of aquatic insects. Increased insect production will improve habitat conditions for fish and amphibians. Additionally, the restored wetlands and vegetated shoreline will provide improved habitat for amphibians. Removing existing residences, lawns, and structures will eliminate sources of nutrients and pollutants to the lake and stream. Mitigation at this site also provides an opportunity to reduce existing hazard wildlife attractants near the airport by reducing habitat for waterfowl that graze on the existing lawn around the lake.

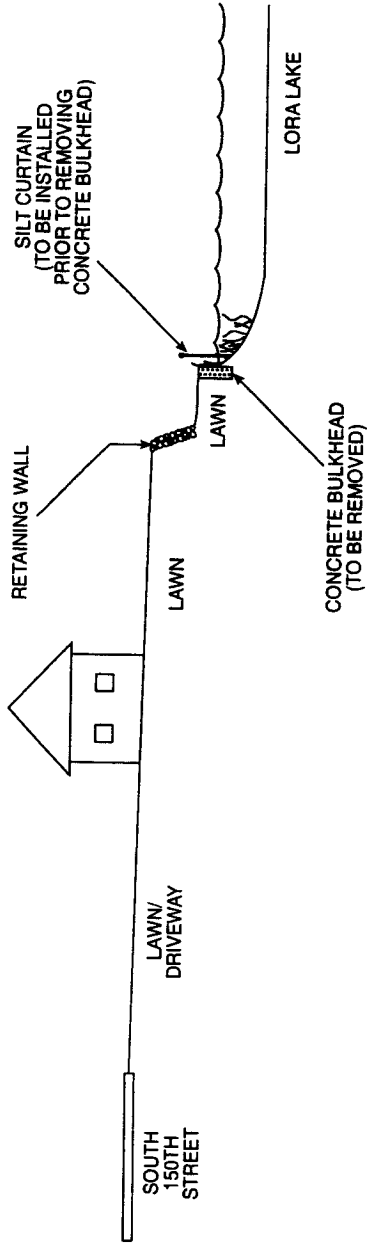
#### 5.1.3.1 Goals, Objectives, and Design Criteria

The goal of the buffer enhancement project is to protect and enhance the aquatic habitats in Lora Lake for aquatic insects, fish, and amphibians by removing shoreline bulkheads and planting native vegetation around the shoreline. Specific design objectives are described in Table 5.1-14.

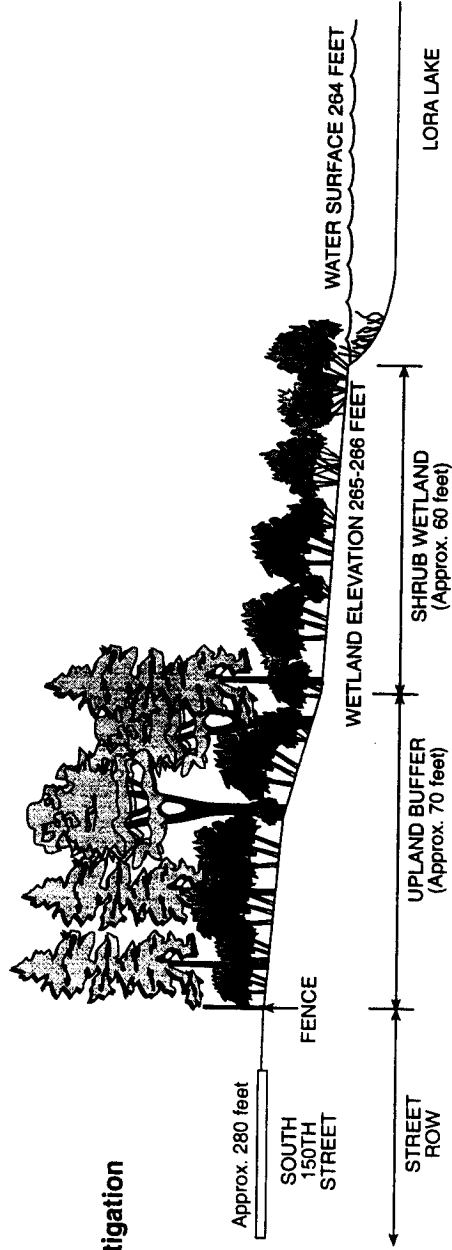
**Table 5.1-14. Mitigation design objectives and criteria for the buffer enhancement projects at Lora Lake.**

| <b>Goals and Design Objectives</b>                                                                                                         | <b>Design Criteria</b>                                                                                                                                                                                                                                                                                                         |
|--------------------------------------------------------------------------------------------------------------------------------------------|--------------------------------------------------------------------------------------------------------------------------------------------------------------------------------------------------------------------------------------------------------------------------------------------------------------------------------|
| Restore more natural shoreline to Lora Lake and improve ecological function of the Lora Lake shoreline to the aquatic habitat of the lake. | The concrete bulkhead will be removed and shoreline graded to a stable slope configuration.                                                                                                                                                                                                                                    |
| Protect and enhance mitigation actions by providing protected upland buffers.                                                              | Remove 1-acre of wetland fill along the north and west side of the lake to restore historic wetland conditions.<br>All structures within the 25-ft buffer will be demolished and failing septic systems (if present) will be removed.<br>Plant upland buffer areas (1.81 acres) around Lora Lake with native trees and shrubs. |
| Vegetate all disturbed areas with native plant communities.                                                                                | Plant native tree species at densities of approximately 280 per acre.<br>Plant native shrub species at densities of approximately 2,100 per acre.                                                                                                                                                                              |

**Existing Conditions**



**Post-Mitigation**



AR 049176

Port of Seattle/Natural Resource Mitigation Plan/556-2912-001/01(03) 11/01 (K)

**Figure 5.1-8  
Typical Cross Section of Lora Lake  
Buffer Enhancement**

VERTICAL SCALE 1" = 40'  
HORIZONTAL SCALE 1" = 40'

### **5.1.3.2 Mitigation Site Description**

Lora Lake is a man-made pond excavated from a natural wetland and located in the northern portion of the Miller Creek floodplain. Lora Lake flows into Miller Creek via a 12-inch concrete culvert on the southeast corner of the lake or via flow at several points over the earthen berm that forms the southern shore of the lake.

Lora Lake was excavated after 1961 and prior to 1970. The residential development along the north and west shore of the lake is partially built on wetland fill that was placed on farmland similar to that occurring on the Vacca Farm site. Cement block bulkhead and riprap retaining walls are located around most of the shoreline on the north and west sides of Lora Lake. Upland areas are located behind the retaining wall and consist of single-family residences, outbuildings, landscaping, mowed lawn, and impervious surfaces such as roads and driveways. Existing septic systems, runoff from roads and rooftops, lawn fertilizers, and pesticides are potential sources of pollutants to Lora Lake, Miller Creek, and associated wetlands. Residential lawns along the lake can also attract waterfowl that graze on the turf grasses.

A narrow band of emergent wetland extends around Lora Lake between the cement bulkhead and the riprap retaining wall, and along the south shore of the lake. Just south of Lora Lake is a large deciduous forested wetland (Wetland A1). Detailed descriptions of Lora Lake and Wetland A1 are included in the *Wetland Delineation Report* (Parametrix 2000b).

### **5.1.3.3 Ownership**

The Port owns all of the parcels within the mitigation area surrounding Lora Lake.

### **5.1.3.4 Rationale for Selection**

Enhancing the shoreline and buffers around Lora Lake provides the opportunity to restore wetlands, enhance water quality in Lora Lake and Miller Creek, and to enhance the function of the restored wetlands in the Vacca Farm floodplain. Removal of existing residences, lawns, and structures will eliminate sources of nutrients and other pollutants to the lake and stream. Wetland functions on the Vacca Farm site will be enhanced by providing buffer protection around the lake and the upper reaches of Miller Creek. Mitigation at this site also provides an opportunity to reduce existing hazard wildlife attractants near the airport.

### **5.1.3.5 Constraints**

There are no constraints associated with implementing this mitigation action. Grading has been avoided in an area where a drainage pipe is present. There is a drainage easement on about 0.01 acre of property for a drainage pipe. The easement also includes maintenance of a rock weir near the Lora Lake shoreline.

### **5.1.3.6 Ecological Assessment of the Lora Lake Shoreline**

#### **Vegetation**

Cement block and riprap bulkheads are located around most of the shoreline on the north and west sides of the excavated lake. Most of the area surrounding Lora Lake on the north and west is impervious surface (i.e., turf grass lawn or buildings and roadways). Vegetation is predominantly non-native turf grasses and ornamental landscaping.

A vegetated berm is located along the southern shore of the lake, with a deciduous forested wetland located south of the berm (Wetland A1). An upland shrub area is located to the east. Dominant species on the vegetated berm include red alder, Himalayan blackberry, and various grass species. The forested wetland contains a prevalence of red alder, black cottonwood, willow, Himalayan blackberry, hardhack, and common cattail. The upland shrub area consists of some Douglas fir (*Pseudotsuga menziesii*), with red alder and dense thickets of Himalayan blackberry.

#### **Soils**

Soils in the wetland areas surrounding Lora Lake and Miller Creek are composed of organic peat deposits from 3.5 ft to 10 ft thick, with lenses of alluvial sands and silts. Fill material associated with buildings around Lora Lake comprises most of the soils in the upland areas. Soils in the area immediately south of Lora Lake have been altered to construct the dike on the south side.

### **5.1.3.7 Lora Lake Shoreline and Wetland Restoration Design**

To enhance the aquatic functions of Lora Lake the concrete bulkhead lining the shoreline will be removed. Existing wetlands fringing the Lake will be enhanced, and about 1 acre of filled wetland will be restored. Upland areas between Des Moines Memorial Drive, South 150<sup>th</sup> Street and Lora Lake will be restored with native tree and shrubs. These changes are illustrated in Figure 5.1-8.

#### **Demolition and Grading**

Residences and various outbuildings, the majority of which are located around Lora Lake, will be demolished prior to implementing this plan. The design includes necessary BMPs to be used throughout demolition activities to prevent sediment from entering the lake or associated wetlands.

Grading activities associated with removing the bulkhead and wetland fill will result in a nearly level wetland area 1-acre in size and about 0.5 to 2 feet above the elevation of the lake. The upland slope on the north and west side of the lake would be established at about 3:1. The restored wetland area would be established near the elevation of buried natural soils. If the peat soils that were historically mapped on the site were removed prior to fill, peat removed from other construction projects will be used to establish wetland soil with high organic matter content.

Prior to planting the buffer areas, grading activities may include roughening the surface, removing portions of lawn, or tilling soil that has been compacted during grading, demolition activities or construction staging. During and following grading, standard TESC measures such as tracking soil surfaces on slopes parallel to the contours will be implemented to prevent erosion.

### **Expected Hydrology**

The areas located below elevation 266 ft feet would be expected to meet the wetland hydrology parameter and support restored wetlands. The groundwater table is high adjacent to the lakeshore, and groundwater seepage emanated from the rock retaining walls on the north and west sides of the lake. Some ground water emanates at about 265-266 ft and is present during the late fall to early summer period. Observations of water leaving Lora Lake throughout the summer months suggest these seep areas are perennial. Wetland areas below about 265.4 ft will become inundated for brief during 100-year flood events.

### **Wildlife Considerations**

The landscape plan has been designed to be consistent with the WHMP and to avoid attracting flocking birds, raptors, and waterfowl. Dense plantings of shrubs broken by scattered trees will discourage use by flocking birds and waterfowl. To deter raptor use of the mitigation sites, deciduous and coniferous trees with stiff branches (such as Sitka spruce (*Picea sitchensis*) or Douglas fir) will be planted in limited quantities. These species will also break up the deciduous tree canopy. This will limit roosting habitat for raptors such as red-tailed hawks. The primary coniferous tree species used in the upland and transitional zones will be western redcedar because its limp branches do not provide ideal raptor perching habitat.

### **Landscape Plan**

Species to be planted in the Lora Lake buffer and wetland restoration areas are identified in Table 5.1-12. The planting plan for the buffer is shown in Figure 5.1-5 and included in the Landscape Plan sheets in Appendix A. The Lora Lake buffer includes species such as black cottonwood and willows for the wetland restoration areas, as well as species such as big-leaf maple and red alder for the drier areas in the buffer.

The landscape plan for the area shows that the planting of conifer trees is phased (see landscape design sheets in Appendix A). It is anticipated that these conifers would be planted in a second planting phase coincident with replacement plantings that may be required to meet the year three performance standard for plant survival. At this time, the conifer species would be planted. The trees will be positioned such that they receive some shade from adjacent plants (trees, shrubs, and groundcover). For the first growing season following this planting, soil moisture conditions will be examined closely, and the use of the temporary irrigation system may be used to reduce mortality and promote growth.

#### **5.1.3.8 Implementation**

Implementation details for Lora Lake are included with the descriptions for the Vacca Farm projects in Section 5.1.4.

#### **5.1.3.9 Monitoring and Performance Standards**

Monitoring for the Lora Lake buffers will follow the overall approach described in Section 4. Detailed performance standards and contingency measures for the Lora Lake buffer are included in Table 5.1-7. Post-construction monitoring will occur for 15 years after installation of the plant material consistent with the schedule in Table 5.1-13.

Monitoring Lora Lake will focus primarily on vegetation to evaluate establishment of native vegetation, consistent with the approach described in Section 4. The Lora Lake site will also be monitored for hazard wildlife, consistent with the monitoring approaches described in Section 4.

#### **5.1.3.10 Site Protection**

The Port will execute and file restrictive covenants for the mitigation area. Copies of proposed restrictive covenants are included in Appendix G. The boundaries of the mitigation area and buffers shall be permanently marked with stakes at least every 100 feet or with fencing. The marking shall include signage that clearly indicates that mowing and fertilizer/pesticide applications are prohibited within mitigation areas. The details of fencing and signage are provided in Appendix P.

Fencing will protect the site from illegal dumping, human use, and may also serve as a security fence for portions of the airport. Where security or wildlife management concerns allow, fencing will allow passage of wildlife.

#### **5.1.3.11 Maintenance and Contingency Plans**

A maintenance plan will be developed for the Lora Lake buffers, as described in Section 4, to guide routine maintenance tasks. Specific contingency measures will be implemented as necessary, consistent with the adaptive management approach. Contingency measures for Lora Lake are listed in Table 5.1-7.

A special monitoring need for this site is to evaluate the several drainage paths that water follows when it exits over the berm of Lora Lake and enters Miller Creek or the Vacca Farm wetlands. Beaver, uprooting of trees, or erosion could alter these hydrologic flow paths which could affect water levels in the lake or the distribution of water to downstream areas. While over time the establishment of greater amounts of tree and shrub vegetation on the berm should create increased stability, in the short term, some changes could create new wetland management opportunities. Evaluation of this feature will provide a basis for adaptive management if needed.

#### **5.1.4 Implementation of the Vacca Farm Mitigation Projects**

Construction associated with building the proposed third runway, including relocation of the South 154<sup>th</sup> Street/South 156<sup>th</sup> Way roadway and sewer line, will be part of the first phase of the proposed Master Plan Update implementation. Relocation of Miller Creek must occur prior to embankment construction, which will fill a portion of the existing channel. The new stream channel must be constructed and stabilized before stream flow can be diverted from the existing channel and before the existing channel can be filled. Construction of the Vacca Farm mitigation projects is therefore currently scheduled to begin during the first construction season (i.e., early summer) following issuance of permits for the project. A general schedule for implementation of the Vacca Farm projects is provided in Table 5.1-15. Detailed plan sheets for the grading and restoration of the banks of Miller Creek at the South 154<sup>th</sup> Street/South 156<sup>th</sup> Way bridge relocation are included in Appendix B, Sheets P1 and P2.



Table 5.1-15. Proposed Implementation Timeline for Vacca Farm Mitigation Projects\*

| Project/Activity                                                                       | Year 1 <sup>a</sup> |   |   |   |   |   |   |   |   |   |   |   | Year 2 |   |   |   |   |   |   |   |   |   |   |   | Year 3 |   |   |   |   |   |   |   |   |   |   |   |
|----------------------------------------------------------------------------------------|---------------------|---|---|---|---|---|---|---|---|---|---|---|--------|---|---|---|---|---|---|---|---|---|---|---|--------|---|---|---|---|---|---|---|---|---|---|---|
|                                                                                        | J                   | F | M | A | M | J | J | A | S | O | N | D | J      | F | M | A | M | J | J | A | S | O | N | D | J      | F | M | A | M | J | J | A | S | O | N | D |
| <b>Miller Creek Relocation</b>                                                         |                     |   |   |   |   |   |   |   |   |   |   |   |        |   |   |   |   |   |   |   |   |   |   |   |        |   |   |   |   |   |   |   |   |   |   |   |
| Pre-construction meeting                                                               | ■                   | ■ |   |   |   |   |   |   |   |   |   |   |        |   |   |   |   |   |   |   |   |   |   |   |        |   |   |   |   |   |   |   |   |   |   |   |
| TESC, Site Preparation                                                                 | ■                   | ■ | ■ | ■ | ■ |   |   |   |   |   |   |   |        |   |   |   |   |   |   |   |   |   |   |   |        |   |   |   |   |   |   |   |   |   |   |   |
| Excavate new stream channel                                                            |                     |   | ■ | ■ | ■ | ■ |   |   |   |   |   |   |        |   |   |   |   |   |   |   |   |   |   |   |        |   |   |   |   |   |   |   |   |   |   |   |
| Install instream habitat features and stream gravels                                   |                     |   |   |   |   |   |   |   |   |   |   |   |        |   |   |   |   |   |   |   |   |   |   |   |        |   |   |   |   |   |   |   |   |   |   |   |
| Produce record drawings of new channel                                                 |                     |   |   |   |   |   |   |   |   |   | ■ |   |        |   |   |   |   |   |   |   |   |   |   |   |        |   |   |   |   |   |   |   |   |   |   |   |
| Install stream diversion measures at tie-ins                                           |                     |   |   |   |   |   |   |   |   | ■ |   |   |        |   |   |   |   |   |   |   |   |   |   |   |        |   |   |   |   |   |   |   |   |   |   |   |
| Trap and relocate fish in existing stream channel                                      |                     |   |   |   |   |   |   |   |   | ■ |   |   |        |   |   |   |   |   |   |   |   |   |   |   |        |   |   |   |   |   |   |   |   |   |   |   |
| Excavate channel tie-ins                                                               |                     |   |   |   |   |   |   |   |   | ■ |   |   |        |   |   |   |   |   |   |   |   |   |   |   |        |   |   |   |   |   |   |   |   |   |   |   |
| Construct new channel banks, install bioengineering and plant channel banks            |                     |   |   |   |   |   |   |   |   | ■ | ■ |   |        |   |   |   |   |   |   |   |   |   |   |   |        |   |   |   |   |   |   |   |   |   |   |   |
| Divert water to new channel                                                            |                     |   |   |   |   |   |   |   |   | ■ | ■ |   |        |   |   |   |   |   |   |   |   |   |   |   |        |   |   |   |   |   |   |   |   |   |   |   |
| Monitor new channel                                                                    |                     |   |   |   |   |   |   |   |   | ■ | ■ |   |        |   |   |   |   |   |   |   |   |   |   |   |        |   |   |   |   |   |   |   |   |   |   |   |
| <b>Vacca Farm Floodplain and Lora Lake Buffers</b>                                     |                     |   |   |   |   |   |   |   |   |   |   |   |        |   |   |   |   |   |   |   |   |   |   |   |        |   |   |   |   |   |   |   |   |   |   |   |
| Preconstruction meeting                                                                | ■                   | ■ |   |   |   |   |   |   |   |   |   |   |        |   |   |   |   |   |   |   |   |   |   |   |        |   |   |   |   |   |   |   |   |   |   |   |
| TESC, Site Preparation                                                                 | ■                   | ■ | ■ | ■ | ■ |   |   |   |   |   |   |   |        |   |   |   |   |   |   |   |   |   |   |   |        |   |   |   |   |   |   |   |   |   |   |   |
| Implement dewatering                                                                   |                     |   |   |   |   |   |   |   |   |   |   |   |        |   |   |   |   |   |   |   |   |   |   |   |        |   |   |   |   |   |   |   |   |   |   |   |
| Mass grade floodplain                                                                  |                     |   |   |   |   |   |   |   |   |   |   |   |        |   |   |   |   |   |   |   |   |   |   |   |        |   |   |   |   |   |   |   |   |   |   |   |
| Fine grade floodplain                                                                  |                     |   |   |   |   |   |   |   |   |   |   |   |        |   |   |   |   |   |   |   |   |   |   |   |        |   |   |   |   |   |   |   |   |   |   |   |
| Install irrigation system                                                              |                     |   |   |   |   |   |   |   |   |   |   |   |        |   |   |   |   |   |   |   |   |   |   |   |        |   |   |   |   |   |   |   |   |   |   |   |
| Install monitoring wells                                                               |                     |   |   |   |   |   |   |   |   |   |   |   |        |   |   |   |   |   |   |   |   |   |   |   |        |   |   |   |   |   |   |   |   |   |   |   |
| Hydroseed graded areas                                                                 |                     |   |   |   |   |   |   |   |   |   |   |   |        |   |   |   |   |   |   |   |   |   |   |   |        |   |   |   |   |   |   |   |   |   |   |   |
| Closeout (remove construction debris and equipment, staging areas, access roads, etc.) |                     |   |   |   |   |   |   |   |   |   |   |   |        |   |   |   |   |   |   |   |   |   |   |   |        |   |   |   |   |   |   |   |   |   |   |   |
| Produce grading record drawings                                                        |                     |   |   |   |   |   |   |   |   |   |   |   |        |   |   |   |   |   |   |   |   |   |   |   |        |   |   |   |   |   |   |   |   |   |   |   |

**Table 5.1-15. Proposed Implementation Timeline for Vacca Farm Mitigation Projects (continued).**

| Project/Activity                                                                                      | Year 1 <sup>a</sup> |   |   |   |   |   |   |   |   |   |   |   | Year 2 |   |   |   |   |   |   |   |   |   |   |   | Year 3 |   |   |   |   |   |   |   |   |   |   |   |
|-------------------------------------------------------------------------------------------------------|---------------------|---|---|---|---|---|---|---|---|---|---|---|--------|---|---|---|---|---|---|---|---|---|---|---|--------|---|---|---|---|---|---|---|---|---|---|---|
|                                                                                                       | J                   | F | M | A | M | J | J | A | S | O | N | D | J      | F | M | A | M | J | J | A | S | O | N | D | J      | F | M | A | M | J | J | A | S | O | N | D |
| Install plants in Vacca Farm floodplain and buffer, and along Miller Creek riparian zone <sup>b</sup> |                     |   |   |   |   |   |   |   |   |   |   |   |        |   |   |   |   |   |   |   |   |   |   |   |        |   |   |   |   |   |   |   |   |   |   |   |
| Install plants in Lora Lake buffer <sup>b</sup>                                                       |                     |   |   |   |   |   |   |   |   |   |   |   |        |   |   |   |   |   |   |   |   |   |   |   |        |   |   |   |   |   |   |   |   |   |   |   |
| Produce planting plan record drawings                                                                 |                     |   |   |   |   |   |   |   |   |   |   |   |        |   |   |   |   |   |   |   |   |   |   |   |        |   |   |   |   |   |   |   |   |   |   |   |
| Conduct baseline monitoring                                                                           |                     |   |   |   |   |   |   |   |   |   |   |   |        |   |   |   |   |   |   |   |   |   |   |   |        |   |   |   |   |   |   |   |   |   |   |   |
| Begin maintenance/monitoring period                                                                   |                     |   |   |   |   |   |   |   |   |   |   |   |        |   |   |   |   |   |   |   |   |   |   |   |        |   |   |   |   |   |   |   |   |   |   |   |

<sup>a</sup> Year one starts with the first construction season following issuance of permits. Implementation of mitigation projects may vary from this proposed schedule depending upon coordination with other Master Plan Update projects, contract obligations, or final approval.

<sup>b</sup> Plant procurement for all projects will be started 6 to 12 months prior to the anticipated planting date to ensure that plants in the specified quantities and species are available by the scheduled planting date. Planting will be phased such that coniferous species will be planted following the third year of monitoring.

#### 5.1.4.1 General Construction Sequencing

Construction of the Vacca Farm projects are currently scheduled to begin during the 2002 construction season (see Table 5.1-15), but the actual schedule is dependent on receipt of federal, state, and local permits. Excavation and grading for the floodplain and stream channel are expected to occur during the driest time of the year, taking approximately 15 weeks, beginning in late June and ending by early October. Instream work associated with the channel relocation will be subject to permit conditions associated with the HPA, and will likely occur between July 15 and September 15.

Construction of the mitigation site will be coordinated with the embankment construction, the South 154<sup>th</sup> Street relocation (including South 156<sup>th</sup> Way bridge relocation), and relocation of the sewer line to ensure that these projects do not impact the mitigation site. In particular, prior to commencing with plant installation, contractors will be required to complete all other work on the site to ensure that plants are not damaged once they are installed.

Construction of Vacca Farm projects will likely take place in several phases. Phase 1 will include most of the earthwork for the Miller Creek channel relocation and floodplain. During Phase 1, the Vacca Farm floodplain will be graded and the irrigation system installed, the new channel will be excavated, and the channel banks stabilized with bioengineering and planted with live stakes. After the new channel grading is complete, tie-ins will be constructed at either end of the new channel where it connects with the existing channel (Appendix A, Sheets C1.1 and C5). Connecting the new channel to the existing channel will require installing water control devices to divert water to the new channel, and implementing measures to protect fish in the existing channel during construction. Connecting the existing stream channel to the new channel, and the diverting water into the new channel, and stabilizing will occur during the first construction season. Grading the Miller Creek floodplain adjacent to the new channel will occur concurrently with channel excavation. Removal of Lora Lake bulkheads and grading of the Lora Lake shoreline may also be included in Phase 1 (Appendix A, Sheet C2), although this work is not dependent on the Miller Creek relocation.

Following completion of Phase 1 earthwork, all open areas on the site (i.e., the channel, floodplain areas, and Lora Lake buffers) will be hydroseeded to provide weed barrier and erosion control prior to winter rains and plant installation. Hydroseed should be applied by mid-September to ensure that the site is adequately stabilized before the rainy season.

During Phase 2, the old channel will be filled for construction of the runway embankment, and planting floodplain wetlands and buffers during the first fall and/or winter following completion of grading. Completion of buffer planting east of Miller Creek will be coordinated with roadway relocation and will likely not be completed until roadway construction is complete. Phase 2 planting includes enhancement planting of the existing wetlands, planting the newly graded areas of the floodplain and riparian zone of Miller Creek, and planting new and enhanced buffer areas along Lora Lake and the east and west sides of the mitigation site (Landscape Plan sheets in Appendix A, Sheets L1 and L2). Plant installation in these areas may require more than one construction season to complete.

### **Phase 1: Site Preparation, Grading, and Channel Relocation**

Earthwork for this phase includes site preparation, installation of sediment and erosion control measures, dewatering if necessary, grading, installation of irrigation, and site stabilization following grading.

#### **Site Preparation and Erosion Control**

No work will begin until the TESC plan is implemented (Appendix A, Sheets TE1 and TE2), nor until any protected or restricted access areas (e.g., wetlands or streams) have been flagged and/or fenced. The TESC plan includes installation of silt fences around the existing wetlands to be enhanced southeast of Lora Lake, and the Lora Lake shoreline, to prevent sediment from the construction site entering these waters (Appendix A, Sheet TE1). A temporary berm will be constructed and a silt fence installed to protect adjacent properties to the south of the mitigation site and prevent water from the construction site from entering the drainage ditch that runs through the center of Wetland A1.

Water from the construction site will likely be directed to the temporary sediment settling pond at the lowest (i.e., southern) end of the proposed floodplain (Appendix A, Sheet TE1). Water from this pond will be allowed to settle until particulates and sediment have settled out. Water from the site can then be discharged via the outlet, quarry spalls, and straw bale filters to Miller Creek (Appendix A, Sheet TE2). Alternatively, construction stormwater runoff may be diverted or pumped to TESC Pond C. Water in the sediment ponds and discharge will be monitored to ensure that turbid water is not discharged to the stream.

Additional TESC measures include placing silt fence around work areas and staging areas, and placing straw bales at key locations within the project limits. Clearing and brush removal will be limited to only those work areas that the contractor is scheduled to begin within the following 2 weeks.

Prior to the start of grading, construction access, staging, and stockpile areas will be set up, and dewatering may be necessary. Temporary access routes and staging areas identified on the western side of the site will be set up and flagged (Appendix A, Sheets C2, TE1). The site will be cleared of debris (e.g., existing tile drains, storm drains and piping, trash, structures).

Construction sequencing of the mitigation site and the roadway/embankment will be carefully coordinated to prevent impacts to the completed mitigation site from roadway construction. Measures to protect the mitigation site from adjacent construction may include orange barrier fencing, sediment and erosion control fencing, and possibly temporary installation of ecology blocks or rock gabions to prevent the intrusion of construction machinery into the mitigation site.

#### **Dewatering**

Due to the high groundwater table throughout the Vacca Farm site, excavation of the floodplain and new channel will likely require dewatering. The dewatering pumps, temporary storage ponds, and sediment and erosion control measures will be installed prior to the start of new channel excavation or floodplain grading. The dewatering system may include excavating dewatering trenches and installing French drains or sumps. The exact location of dewatering trenches and temporary storage

ponds will be determined by the contractor. The location of these dewatering features may change as the excavation and final grading of the floodplain proceeds; however, all dewatering wells, temporary storage ponds, and/or trenches will be within the area to be excavated for the floodplain grading (Appendix A, Sheets C2, TE2). In addition, all water from dewatering areas will be directed to sediment settling ponds and any sediment will be allowed to settle prior to being discharged via a quarry spill outfall and straw bale filters to Miller Creek (see Appendix A, Sheet TE2). All dewatering features will either be removed as a consequence of the ongoing excavation (e.g., trenches, drains) or removed and the area graded once they are no longer needed (e.g., temporary storage ponds).

### **New Channel Excavation and Floodplain Grading**

New channel construction includes excavation of the new channel, stabilization of channel banks, installation of stream gravels and woody debris, implementation of fish protection measures, construction of the tie-ins to the existing channel, diversion of water to the new channel, and filling in the old channel. Construction in the existing channel will likely take place between July 15 and September 15, consistent with conditions in the HPA.

The new channel will be excavated and water diverted from the existing channel within the same construction season. The new channel banks will be adequately stabilized to carry dry and wet season flows using bioengineering (e.g., coir lifts with live stakes, erosion control fabric) (Appendix A, Sheets C5 and L2). Channel banks will be planted densely with willow stakes to provide additional stabilization and channel roughness. The dry and wet season base flows in this portion of Miller Creek are typically low (< 5 cfs) and the new channel slope is very gradual. Therefore, even during storm events, flows in Miller Creek through this reach will not have large amounts of energy. Furthermore, the channel has been designed with a low-flow channel inside a wider channel meander zone, which can accommodate up to annual peak flows (Appendix A, Sheet C5). Flows greater than annual peak flows will flood onto the floodplain, rapidly attenuating the energy and erosive force of high flows.

The sequence of steps required to divert existing flows to the new channel will be consistent with HPA permit conditions and will be conducted to reduce stress and impacts on aquatic organisms. Prior to constructing tie-ins and diverting Miller Creek to the new channel, the section of the existing channel to be diverted will be closed off, and fish within the existing channel will be captured and relocated to a point downstream of South 160<sup>th</sup> Street where suitable habitat exists. Fish capture and relocation will be done under the supervision of a qualified fish biologist with a collection permit from the WDFW.

Immediately following fish capture, the tie-ins will be constructed, and flow from the existing channel will be intermittently introduced to the new channel section to allow the streambed gravels to sort and stabilize. Flows will be intermittently introduced to the new channel with a gate valve or other control structure to allow flows to be metered. During this time a collection sump located at the downstream end of the new channel will collect water. Turbid water will be conveyed to a sediment pond until the new channel flows clear. After diversion of stream flow has been successfully completed, the existing channel will be filled during embankment construction.

Excavation of the floodplain grades at Vacca Farm may occur concurrently with the new channel excavation. Floodplain grading will begin as soon as the contractor can control the groundwater sufficiently for excavation. Grading will occur on all areas of the mitigation site with the exception of the existing wetland to the east of Lora Lake (i.e., between Lora Lake and Miller Creek) and the area of upland buffer along the western portion of the site (Appendix A, Sheets C1.1 and L1). Existing drainage ditches on the site will be filled and removed during grading to restore site hydrology. A swale will be constructed through the floodplain to allow it to drain gradually to the south and prevent standing water (Appendix A, Sheet C2). Cross sections in the plan sheets show the proposed site elevations following grading (Appendix A, Sheets C1.2 and C4). In addition to floodplain grading, existing bulkheads along the north and west shoreline of Lora Lake will be removed and a more gradual slope will be restored to the lake shoreline. Removal of the bulkheads prior to planting buffer vegetation will enhance the function of the buffer to be planted along Lora Lake.

### **Installation of Temporary Irrigation and Site Stabilization**

Once the new wetland, buffer, and floodplain grades have been established and verified by field survey, the temporary irrigation system will be installed (Appendix A, Sheets L1 through L3). This system will be used to provide flexibility in the planting schedule, provide contingencies against periods of dry weather during the first few growing seasons, and to maximize plant survival and growth during the first years following planting. Allowing for maximum plant growth during the first years of restoration will expedite establishment of cover and shade on the site, production of biomass, vertical habitat structure, and organic litter. This will help reduce temporal impacts.

Irrigation is a standard feature of wetland mitigation construction in the Puget Sound Lowlands due to the region's pronounced summer drought. Irrigation will be designed for the entire area to be graded at Vacca Farm; however, it may not be necessary in some areas. If, following grading, the wetland scientist determines that irrigation is not needed in some areas, it will not be installed.

Municipal water will be used for irrigation. It is anticipated that the irrigation system would be used for the months of June through September, but actual timing will be dependent on weather and soil moisture conditions. Application rates will be sufficient to reduce plant mortality and promote growth during dry periods. In upland buffers that contain well-drained soils, earlier and more frequent use may be required. The irrigation system will be decommissioned and all aboveground parts removed at the direction of the wetland scientist once plant survival standards have been met.

The site will be stabilized following completion of grading and prior to the onset of winter rains. A hydroseed mix designed to provide temporary erosion control and a weed barrier will be applied to the graded floodplain areas by mid-September.

### **Phase 2: Establish Native Vegetation in the Miller Creek Channel, Floodplain, and Buffer**

The channel area will be planted as soon as channel excavation is complete. In areas with irrigation, planting will not be limited to fall or winter planting seasons; in areas lacking irrigation, planting will occur only during the fall and/or winter months. The stream buffer and adjacent floodplain can be planted after site grading and irrigation installation is complete and hydroseed has become established.

It is anticipated that floodplain and buffers, stream riparian zone and buffers, and Lora Lake buffer planting will begin the first fall (i.e., October or November) following grading and irrigation installation. Planting the entire site will likely require more than 1 year to complete. Immediately following plant installation, the area between plants will be mulched or covered with a weed control fabric to reduce establishment of weeds. Stem collars or other herbivore deterrents may be installed on plants to reduce damage from rodents and other herbivores.

Soils on the Vacca Farm site are a mix of inter-bedded peat, sand, silt, and gravel. Following excavation and grading, the material exposed at the surface will likely vary from predominantly peat to a mix of sands, gravels, and silts. To ensure a medium suitable for plant establishment, 12 to 14 inches of prepared topsoil will be spread over the surface following grading. Where feasible, the prepared topsoil will be comprised of native materials from the site, mixed to obtain a topsoil with a 3:1 mineral to organic material mix. Where not feasible, prepared topsoil will be a 3:1 mix of clean sand with organic compost that is free of weed seed or other unsuitable material.

Plant material used in the mitigation will be obtained from commercial nurseries. Nurseries will be required to certify that the plant material is legally procured and from the appropriate geographic sources. Plant material used for mitigation will be grown in the area that is bounded on the north by the Fraser River Valley of British Columbia, on the east by the 1,000-ft elevation of the Cascades, on the west by the 1,000-foot elevation in the Olympic or Coast ranges, and on the south by the Willamette Valley.

#### **5.1.4.2 Construction Steps**

The following sections outline the construction and post-construction steps necessary to implement the Mitigation Plan for the Vacca Farm site.

##### **General Conditions**

- On award of the contract, the contractor will provide the Port with any required pre-construction submittals, work plans, and schedules.
- A pre-construction meeting will be held with the contractor, architect/engineer, and wetland scientist to review submittals, work plans, schedules, and permit conditions.
- The contractor will be responsible for ensuring that the work is performed in compliance with all permit conditions and shall maintain a copy of permits on-site.
- Work will be coordinated to avoid re-entry and damage to areas that have previously been planted; work will be conducted so that no other work will impact completed landscape work.
- Areas where any landscape work has been completed will be off limits to all vehicular traffic, and pedestrian traffic will be strictly limited.
- All site work will be performed in accordance with permit conditions; any instream work or work below Ordinary High Water (OHW) will take place only during the allowable work times, consistent with HPA permit conditions (i.e., July 15 to September 15).

- Plant procurement shall be coordinated with the grading and irrigation installation schedules and be completed 6 to 12 months prior to the scheduled planting season to ensure that plants are available in the quantities and species required by the planting plan.

### **Site Preparation**

- Establish vertical and horizontal site controls and maintain through construction to record drawings.
- Identify and flag limits of work for mitigation site.
- Identify staging areas and temporary access/haul roads.
- Implement TESC plan; install TESC measures for all projects, including the Miller Creek channel relocation, floodplain grading, Lora Lake buffer planting, and Miller Creek buffer enhancement areas.
- Identify and flag sewer manholes and sewer easement.
- Install fencing (orange barrier) around areas to be protected (e.g., existing wetlands, outlet ditches, sewer manholes).
- Maintain security of the site through construction.
- Establish temporary access/haul roads.
- Establish staging and stockpile areas.
- Implement a spill control plan and identify fueling areas.
- Install site dewatering equipment and structures (e.g., pumping wells, manifold piping, temporary storage ponds, discharge structure).

### **Clearing, Excavation, and Grading**

- Clear and grub the site.
- Implement dewatering for new channel construction, if necessary.
- Fill in or remove drainage ditches.
- Excavate new channel subgrades (except at tie-in areas).
- Confirm new channel subgrades with field survey.
- Install log weirs and quarry spalls.
- Place streambed material and grade low-flow channel.
- Confirm new channel finish grades.
- Construct new channel banks; install coir fabric-wrapped streambank material.
- Install coir logs and coir mattresses.
- Install instream habitat features in new channel.
- Install channel plantings and bioengineering.



- Install shade cloth.
- Remove weeds (e.g., grub out blackberry and reed canarygrass; apply herbicide if appropriate per specifications) and clear brush in wetland buffer enhancement areas.
- Mass and fine grade floodplain.
- Install microtopography/LWD on floodplain.

#### **Construct New Channel Tie-Ins to Existing Channel**

- Implement fish-protection and erosion control measures for tie-in construction.
- Install sheeting and base flow stream diversion sumps at tie-in areas.
- Excavate new channel grades at tie-in areas.
- Install transition area log weirs and quarry spalls at tie-in areas.
- Place streambed (spawning) gravel and grade low-flow channel at tie-in areas.
- Confirm new channel finish grades.
- Construct new channel banks.
- Install coir logs and coir mattresses at tie-in areas.
- Install bioengineering.
- Divert water into new channel.
- Place fill in existing channel at tie-in areas.
- Prepare grading record drawings for new channel and floodplain; modify planting plans as needed to match as-built grades and site conditions

#### **Irrigation and Landscaping**

- Install and test irrigation system in floodplain.
- Apply hydroseed to graded portion of the floodplain.
- Winterize irrigation system.
- Begin planting in fall/winter following grading.
- Plant riparian/buffer zone of new channel.
- Plant Miller Creek floodplain and other wetland enhancement areas.
- Plant upland buffer adjacent to floodplain and Lora Lake buffers.

#### **Closeout**

- Complete site cleanup by removing temporary haul/access roads, TESC berm, and staging areas.
- Remove construction equipment and debris.

- Hydroseed and/or install plants in temporary staging areas or access roads within the mitigation site boundaries.
- Hydroseed erosion control mix in temporary staging areas/access roads outside the mitigation boundaries.

#### **Record Drawings, Monitoring, and Maintenance**

- Produce record drawings (including grading, instream habitat, and planting) for all project areas (e.g., Lora Lake buffers and shoreline, Miller Creek floodplain, relocated channel, and Miller Creek buffer between new channel and South 154<sup>th</sup> Street/South 156th Way bridge).
- Complete a baseline report, including record drawings and final monitoring plan (e.g., locations of monitoring plots, baseline conditions).
- Begin compliance monitoring during the first growing season after all grading and planting are complete; submit annual monitoring reports for 15-year monitoring period.
- Conduct maintenance (e.g., weed management, WHMP) and implement any necessary contingency measures to meet performance standards.

**AR 049190**



## 5.2 MILLER CREEK RIPARIAN AND INSTREAM ENHANCEMENT PROJECTS

Mitigation along Miller Creek from the Vacca Farm site to Des Moines Memorial Drive is designed to establish a large, contiguous habitat corridor extending approximately 6,500 ft along the stream, connecting habitats that are currently fragmented by urban land uses. Within this corridor, instream, wetland, and non-wetland riparian habitats will be restored and enhanced. Removing channel armoring, restoring more natural channel morphology, and installing habitat features at selected areas will restore instream habitat in Miller Creek. Removing structures, impervious surfaces, and non-native vegetation and planting with native wetland vegetation will be enhanced many of the riparian wetlands along Miller Creek. Non-wetland riparian buffers along Miller Creek will be enhanced to stabilize soil; retain sediments and nutrients; and provide shade, organic matter, and woody debris to the stream.

Mitigation measures along Miller Creek will also be implemented to compensate for filling existing drainage channels, maintain the hydrology of wetlands between Miller Creek and the new runway embankment, and mitigate temporary construction impacts to wetlands. These mitigation actions are designed to prevent indirect hydrologic impacts to wetlands downslope of the embankment. Replacement drainage channels will be constructed to maintain inputs from surface water runoff and groundwater seepage to wetlands downslope of the new embankment, and wetlands temporarily impacted by construction will be restored to pre-construction conditions.

To compensate for unavoidable project impacts to wetlands and streams, the Miller Creek buffer and instream enhancement projects include the following specific mitigation actions:

- Restoring and enhancing functions in approximately 7.4 acres of riparian wetlands along both sides of a 6,500-ft reach of Miller Creek, between the Vacca Farm site and Des Moines Memorial Drive (Section 5.2.1)
- Restoring and enhancing a native, forested riparian buffer corridor along the east and west sides of this 6,500-ft section of Miller Creek to protect and improve aquatic habitat in the stream, associated drainage channels, and riparian wetlands (Section 5.2.1)
- Establishing a large, contiguous, protected riparian habitat corridor connecting the upper and lower reaches of Miller Creek (Section 5.2.1)
- Restoring fish and aquatic habitat to degraded, highly modified reaches of Miller Creek by adding LWD and boulders, reconstructing natural stream channels, removing man-made obstructions, and reshaping or stabilizing streambanks (Section 5.2.2)
- Replacing approximately 1,290 linear ft of drainage channels near 12<sup>th</sup> Avenue South to compensate for existing drainage channels that will be filled by the third runway embankment (Section 5.2.3)
- Restoring wetland and upland plant communities to Wetland A17 to mitigate for the temporary impacts of construction (temporary impacts will also be restored as described in Section 5.2.4, and this mitigation thus reduces duration of these impacts).
- Improve channel conditions in Water D (1,830 linear feet) through riparian plantings and wood placement.

- Encouraging and promoting additional local stream restoration efforts in the basin; the Port will create a \$150,000 trust fund to be used for stream restoration projects in the Miller Creek basin (Section 5.2.5)

### **5.2.1 Miller Creek Riparian Corridor Wetland and Buffer Enhancement Plan**

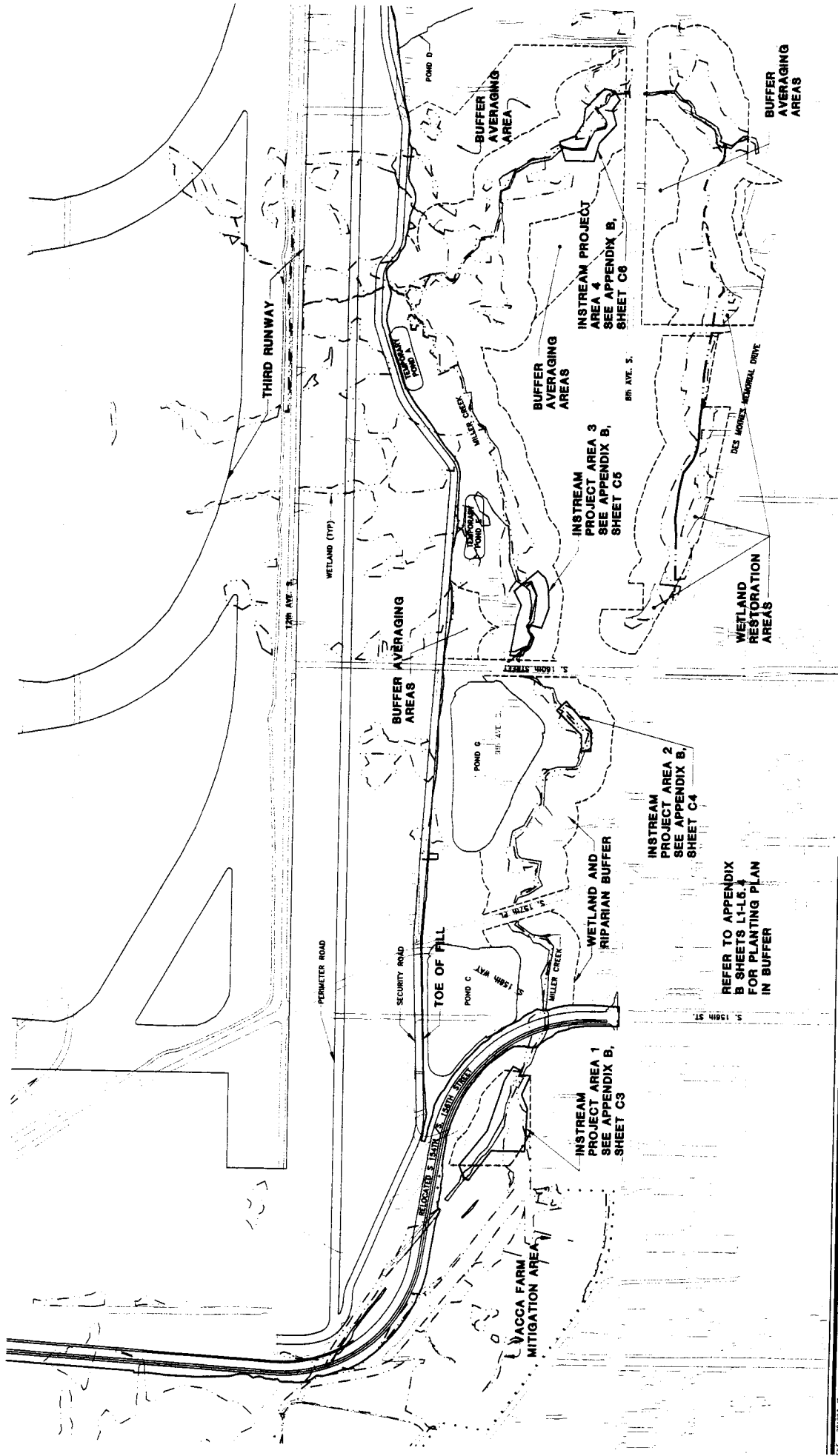
Physical and biological functions will be enhanced along approximately 6,500 ft of Miller Creek. Protection and enhancement of the riparian area will enhance the physical functions forested buffers provide, including reducing stream water temperatures, reducing erosion and suspended sediment releases to streams, influencing channel morphology by contributing LWD to the channel, and stabilizing the banks. Riparian restoration will also enhance biological functions of stream buffers, such as increasing nutrient cycling and retention, increasing organic carbon export to the stream, and providing habitat and food resources to aquatic organisms.

As a consequence of past development in the Miller Creek watershed, buffers have been removed or degraded along much of the stream. Native forested vegetation has been replaced by impervious surfaces, ornamental turf grasses, or landscaping. These alterations reduce the ability of the existing buffer to support the biological and physical functions necessary to maintain quality habitat in adjacent streams.

To restore functions to aquatic resources, riparian wetlands, and buffer along Miller Creek, a buffer area that averages a minimum of 100 ft wide on both banks of the stream (approximately 40 acres) will be enhanced (Figure 5.2-1; Appendix B). Approximately 10.25 acres of riparian wetland habitat and approximately 40.86 acres of buffer will be enhanced. Buffer and wetland enhancement activities along Miller Creek include removal of all residential structures and associated impervious surfaces, underground oil storage tanks, and septic systems. Non-native, invasive species will be removed from wetlands and riparian areas where they would prevent the establishment of native vegetation, and where removal will not destabilize stream banks or result in increased sedimentation.

These specific areas are shown as shaded zones on the landscape sheets in Appendix B. The wetlands and riparian buffer will be enhanced by planting areas of existing lawn, predominantly non-native vegetation, or disturbed areas (i.e., from which structures or impervious surfaces have been removed) with native, predominantly forested vegetation (Figure 5.2-2 and on the Landscape Plan sheets in Appendix B). Wetland or riparian buffer areas, which currently are predominantly forest or shrub vegetation, will be enhanced with in-fill planting of native trees or shrubs.

Design of the Miller Creek wetland and riparian buffer enhancements has been coordinated with the design and location of stormwater detention ponds, the South 156<sup>th</sup> Way bridge replacement, location of airport security roads and utility easements, and replacement drainage channels (see Section 5.2.3). Appropriate BMPs will be implemented and construction activities sequenced to ensure there are no impacts to buffer enhancement projects from other mitigation or Master Plan Update improvements construction activities (see Implementation, Section 5.2.2.10 for details).



**Figure 5.2-1  
Miller Creek Instream and  
Buffer Enhancements**

- NOTES:**
1. ACCESS TO PROJECT SITES BY APPROVAL OF ENGINEER.
  2. WETLAND AREAS NOT TO BE DISTURBED BY EQUIPMENT. WETLAND AREAS WILL BE STAKED AND MARKED IN THE FIELD BY THE ENGINEER OR BIOLOGIST.

- LEGEND**
- MILLER CREEK
  - ▨ WETLANDS
  - ▨ BUFFER AVERAGING AREA
  - ▨ WETLAND RESTORATION AREA
  - ▨ WETLAND AND RIPARIAN BUFFER
  - ▨ INSTREAM PROJECT AREA
  - ▨ VACCA FARM MITIGATION AREA
  - ▨ WETLAND RESTORATION AREA
  - ▨ RIPARIAN BUFFER

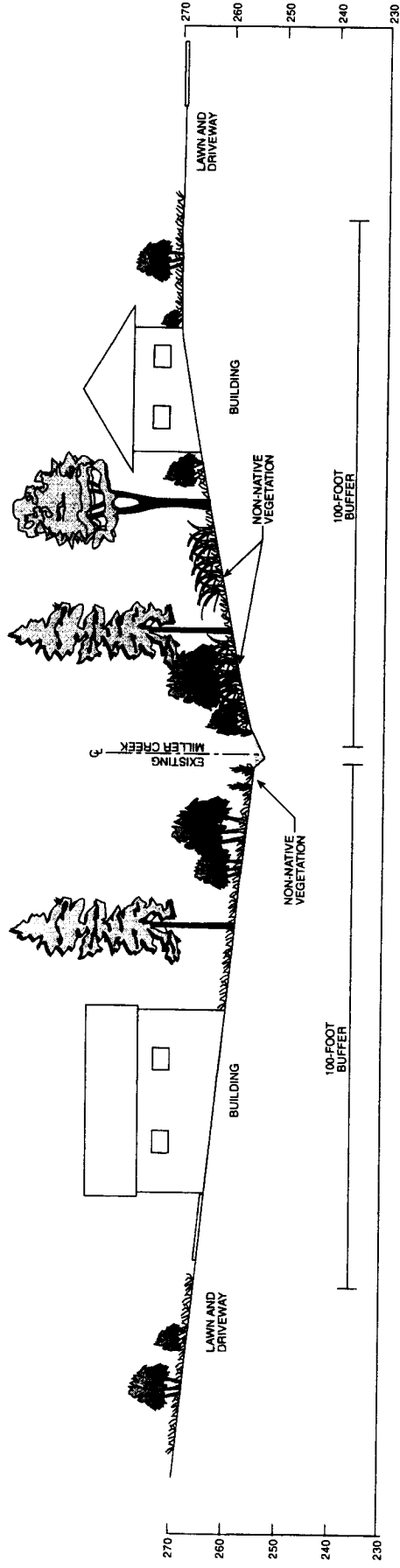


0 175 350  
SCALE IN FEET

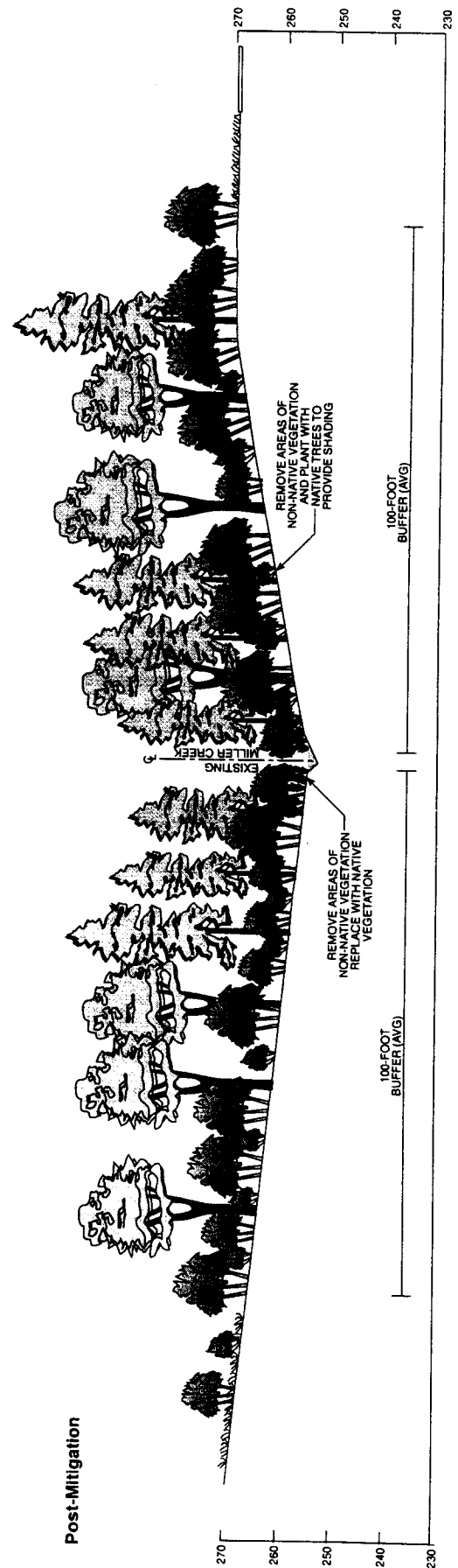
FILE: 29103.D  
DATE: 11/16/01

**AR 049194**

**Existing Conditions**



**Post-Mitigation**



**Figure 5.2-2  
Typical Cross Section of Miller Creek  
Stream Buffer Enhancement**

VERTICAL SCALE 1" = 30'  
HORIZONTAL SCALE 1" = 30'

### 5.2.1.1 Goals, Objectives, and Design Criteria

The primary goals of the buffer enhancement plan are to enhance functions in riparian wetlands and in aquatic habitat within and downstream of the Miller Creek riparian corridor by restoring a forested buffer along the entire length of Miller Creek in the acquisition area (Table 5.2-1).

**Table 5.2-1. Mitigation goals, design objectives, and design criteria for the Miller Creek wetland and buffer enhancement project.**

| Goals and Design Objectives                                                                | Design Criteria                                                                                                                                                                                                                                                                                                                                                                                         |
|--------------------------------------------------------------------------------------------|---------------------------------------------------------------------------------------------------------------------------------------------------------------------------------------------------------------------------------------------------------------------------------------------------------------------------------------------------------------------------------------------------------|
| <b>Goal: Enhance aquatic habitat in the Miller Creek by establishing a forested buffer</b> |                                                                                                                                                                                                                                                                                                                                                                                                         |
| Restore approximately 40.86 acres of riparian buffer along Miller Creek.                   | Demolish existing structures; remove maintained lawn, landscaping, and portions of non-native vegetation located within 100 ft of Miller Creek (or its adjacent wetlands), and buffer averaging areas.<br><br>Remove potential water quality impacts such as failed septic systems and untreated stormwater runoff from the buffer area.                                                                |
| Enhance wetland and riparian areas.                                                        | Riparian buffer areas that are cleared or disturbed during demolition will be planted with native forested and shrub vegetation.<br><br>Plant native tree species at densities of greater than 280 per acre.<br><br>Plant native shrub species at densities of greater than 2,100 per acre.<br><br>Planting native forest vegetation will enhance lawn and other areas dominated by non-native species. |
| Increase shade, detritus input, and organic matter retention in the aquatic environment.   | Densely plant the portion of the buffer adjacent to the stream with native trees and shrubs where applicable to provide overhanging vegetation and provide future sources of LWD to the stream.                                                                                                                                                                                                         |
| Reduce erosion and sedimentation to Miller Creek.                                          | Remove existing structures, such as riprap walls and bridges, to reduce channel scouring.<br><br>Increase sediment retention in the buffer by planting trees and shrubs.                                                                                                                                                                                                                                |
| Provide long-term protection to the Miller Creek Buffer.                                   | Establish restrictive covenants to permanently protect buffer.<br><br>Install fencing and signs to designate area as protected mitigation site.                                                                                                                                                                                                                                                         |

### 5.2.1.2 Mitigation Site Description

The section of Miller Creek includes the riparian enhancement projects is located along both sides of the stream between the southern portion of the Vacca Farm site and where the stream flows under Des Moines Memorial Drive (Appendix B, Sheet C2).

The Miller Creek buffer was established by adding a 100-ft buffer from the Ordinary High Water Mark (OHWM) of Miller Creek or from the edge of riparian wetlands (riparian wetlands are those that are directly associated with Miller Creek). Approximately 4.8 acres of permanent detention ponds, relocated South 154<sup>th</sup> Street/South 156<sup>th</sup> Way, and the third runway embankment will encroach into this buffer. Additionally, an existing 20-ft wide sanitary sewer pipe easement (1.7 acres) was calculated as an encroachment. Buffer averaging was applied at three locations along the stream to compensate for these encroachments. The upland buffers and buffer averaging areas total approximately 40.86 acres (Appendix J).



The riparian buffer vegetation consists primarily of turf grass lawns, areas of ornamental non-native landscaping, or non-native invasive plant species such as Himalayan blackberry, English ivy (*Hedera helix*), and Japanese knotweed (see Figure 5.2-2). Existing land uses in the buffer area include residential structures (such as houses and outbuildings), roads, small stock farms, and horse pastures. In small patches along the channel and in several wetland areas adjacent to the stream, native tree and shrub species occur such as red alder, black cottonwood, Pacific and Sitka willow, hardhack, lady fern (*Athyrium felix-femina*), horsetail, and various native and non-native grasses.

Twenty-five wetlands are present within the Miller Creek buffer and buffer averaging areas (see Table 3.1-4). These wetlands are 18, 37, A1, A9, A10, A11, A13, A16, A17, R1, R2, R3, R4, R5, R6, R7, R8, R9, R10, R11, R12, R13, R14, R15a, and R17. A complete description of these wetlands is provided in the *Wetland Delineation Report* (Parametrix 2000b).

### **5.2.1.3 Ownership**

All parcels within the riparian wetland and buffer enhancement area shown in Figure 5.2-1 are owned by the Port.

### **5.2.1.4 Rationale for Selection**

Restoring the riparian habitat along this reach of Miller Creek provides on-site and in-kind mitigation opportunities to replace wetland and stream functions impacted by the project. Despite past degradation, the downstream reaches of Miller Creek contain habitat for salmonids. Acquisition, permanent protection, and restoration of a significant portion of Miller Creek have the potential to significantly enhance wetland and aquatic habitats in the Miller Creek basin, including downstream segments not within the project area. Removing residential land uses and associated non-point source pollution and physical impacts, such as clearing and dumping, will enhance the wetland and riparian plant communities, as well as water quality and aquatic habitat within the stream.

The planned restoration and enhancement of the Miller Creek riparian corridor provide an exceptional opportunity to remove anthropogenic impacts, and to establish a large, contiguous riparian habitat corridor within a highly urbanized watershed. Few such opportunities exist to perform habitat restoration at this scale on significant salmonid-bearing streams in urban environments.

### **5.2.1.5 Constraints**

There are no constraints to implementing the mitigation as proposed. Specific mitigation actions have been limited in portions of the mitigation area affected by steep slopes or existing native vegetation. For example, in areas that cannot be accessed without causing increased erosion, or disturbance to desirable vegetation, enhancement actions are not planned.

A concern identified for this mitigation area has been the presence of an existing sewer line easement owned by the Southwest Suburban Sewer District. Occasional maintenance of this line would be required within the 20-foot easement, and this maintenance<sup>25</sup> could prevent mature vegetation from developing within the easement (see Landscape Plan Sheets in Appendix B). For these reasons, this area of the easement is removed from the mitigation buffer, and an equivalent area that can be fully protected from future disturbance has been added to the mitigation area. The presence of the sewer line will not reduce or alter the ecological functions derived from the mitigation. Its presence has, in fact, increased the area of land set aside for protection.

A water main and easement are present in the mitigation site near Wetland A17.

#### **5.2.1.6 Ecological Assessment of the Mitigation Site**

Ecological conditions relevant to the mitigation design and implementation are discussed in this section.

##### **Hydrology**

The majority of the proposed buffer zone contains uplands and areas of riparian and non-riparian wetlands. Seasonal soil saturation can occur in some of the upland areas near the stream. Inundation of some riparian wetlands occurs during the high-flow periods that may occur in late fall, winter, and spring. Soils in most of the riparian wetlands remain moist during the summer months, and portions of some wetlands (e.g., Wetlands 18 and 37) remain perennially saturated. Non-riparian wetlands in the buffer area are typically saturated during the late fall through early summer period.

Evaluations of project impacts to wetlands (Parametrix 2001b) demonstrate that, with the proposed mitigation, groundwater will continue to be available to support wetlands protected by the Miller Creek buffer. Mitigation to further protect and monitor these wetlands is discussed in Section 5.2.3.

##### **Soils**

The project area has not been mapped by the Soil Survey of King County Area Washington (Snyder et al. 1973). However, various soil test pits were dug during field investigations for wetland delineations within the Miller Creek area. Alluvial soils with high organic matter were found in the small riparian wetlands. Soils throughout the remainder of the Miller Creek riparian corridor, south of the Vacca Farm site, are disturbed due to residential development, but appear to be typical Alderwood soils (Snyder et al. 1973). Alderwood series are primarily made up of moderately well

---

<sup>25</sup> Sewer lines generally have a design life in excess of 50 years, and rarely require maintenance or fail. Therefore, the potential for disturbance of the easement area is small and infrequent. Furthermore, if leaks were to develop in the line, there are methods to repair and rehabilitate sewer lines in-situ with no disruption of surface soils. These methods employ installation of new pipe sleeves or pipe liners within the existing pipe. Installation is done through existing manholes without soil excavation. These are the preferred methods for rehabilitating sewer lines, and are routinely used by large and small sewer utilities. The easement width of 20 ft provides sufficient construction area for maintenance, repair, or rehabilitation needs.

drained soils forming on glacial till. In some areas, soils were predominantly a sandy loam, with a soil profile that corresponds to Indianola soils (Snyder et al. 1973).

### **Vegetation**

South of the Vacca Farm site, between South 156th Way and South 160<sup>th</sup> Street, the riparian vegetation is a complex mix of types. Areas of residential landscaping, such as lawns and ornamental plantings, and areas of non-native invasive vegetation, are intermixed with areas of native upland and wetland vegetation. Non-native dominant plants include such invasive species as Himalayan blackberry, Japanese knotweed, and English ivy.

Riparian vegetation south of South 160<sup>th</sup> Street is more often dominated by native plant species than the area between Vacca Farm and South 160<sup>th</sup> Street. Common species identified in the canopy layer include red alder, western redcedar, English holly (*Ilex aquifolium*), and some Douglas fir. Dominant species in the shrub layer consist of Himalayan blackberry, salmonberry (*Rubus spectabilis*), willow, and Indian plum (*Oemleria cerasiformis*), with horsetail species, lady fern, swordfern (*Polystichum munitum*), and various upland and wetland grasses in the herbaceous layer.

To assess the extent of non-native vegetation located within 100 ft of the stream, a vegetation survey was conducted along each parcel that borders Miller Creek. Detailed descriptions of the vegetation in each parcel within the riparian buffer are provided in Appendix B, Sheets L1 through L6.

#### **5.2.1.7 Miller Creek Wetland and Riparian Buffer Enhancement Mitigation Design**

Conditions along Miller Creek vary widely in terms of existing vegetation, presence of structures, and percent cover of non-native invasive species. Due to this variation, a single mitigation design is not appropriate for the entire buffer area. Given the range of existing conditions, four different buffer-enhancement actions will be implemented, depending on site-specific conditions (Table 5.2-2 and on the Landscape Plan sheets in Appendix B, Sheets L1 through L5). Specific performance standards for the buffer enhancement area are provided in Table 5.2-3. Depending on existing conditions in a given part of the buffer, mitigation actions may include one of the following:

- Removing structures and/or existing non-native invasive vegetation, and re-planting with native vegetation (i.e., clearing and re-planting)
- Controlling and managing patches of non-native invasive vegetation, and re-planting with native vegetation (i.e., invasive management and re-planting)
- Retaining the existing native vegetation matrix but infill planting to increase species diversity and habitat structure (i.e., infill planting)
- Retaining and protecting existing native vegetation with the designated buffer (i.e., protection)

**Table 5.2-2. Enhancement planting approach along the Miller Creek buffer.**

| Enhancement Activity                                                                   | Explanation and Comments                                                                                                                                                                                                                                                                                                                                                                                                                                                                                                                                                                                                                                                                                                                                                                                                                                                                                                                                                                                                                                                                                                                                                                                                                                                                                                                                                                     |
|----------------------------------------------------------------------------------------|----------------------------------------------------------------------------------------------------------------------------------------------------------------------------------------------------------------------------------------------------------------------------------------------------------------------------------------------------------------------------------------------------------------------------------------------------------------------------------------------------------------------------------------------------------------------------------------------------------------------------------------------------------------------------------------------------------------------------------------------------------------------------------------------------------------------------------------------------------------------------------------------------------------------------------------------------------------------------------------------------------------------------------------------------------------------------------------------------------------------------------------------------------------------------------------------------------------------------------------------------------------------------------------------------------------------------------------------------------------------------------------------|
| Remove structures and/or non-native invasive vegetation and re-planting.               | <p>This enhancement approach includes planting disturbed areas after structures have been removed from the site. Activities may include grading within the existing buffer to remove houses, driveways, and other structures. If necessary, soil will be scarified and/or amended with organic material.</p> <p>Non-native invasive species such as Himalayan and evergreen blackberry), Japanese knotweed, bamboo (<i>Bambusa</i> sp.) and English holly (<i>Ilex aquifolium</i>) will be removed from certain portions of the buffer; these areas are shaded on the Landscape Plan sheets in Appendix B. Removal of non-native invasive plants will depend upon vehicular access, the potential risk of sedimentation in wetlands or Miller Creek from vegetation removal, and whether or not invasive species can be controlled adequately without removal. Areas of non-native invasive species will be wholly removed only where there is appropriate access and if existing desirable vegetation will not be adversely affected.</p> <p>Re-vegetation will consist of planting native trees and shrubs in areas, such as lawns associated with residences, that do not currently have an overstory of vegetation. Understory planting will occur in forest areas that lack understory shrubs. Native trees and shrubs to be used in these enhancements are listed in Table 5.1-12.</p> |
| Invasive vegetation control and/or management, and re-planting with native vegetation. | <p>Non-native invasive species such as Himalayan and evergreen blackberry, Japanese knotweed, bamboo, and English holly will be controlled and managed in certain portions of the buffer where removal is not necessary or possible. For example, invasive species within the buffer may be left in place if removal could cause erosion or sedimentation to the stream or adjacent wetlands.</p> <p>In some areas, patches of invasive species may be treated with herbicide and/or physically removed. These patches may range in size from approximately 200 to 600 ft<sup>2</sup>. Coniferous tree species will be planted in the open area to promote reforestation that would eventually shade out invasive species. These plantings will also provide diversity, seed stock, and recruitment of LWD into the riparian buffer.</p>                                                                                                                                                                                                                                                                                                                                                                                                                                                                                                                                                     |
| Infill planting in existing native/non-native vegetation.                              | <p>Native trees and shrubs will be planted to increase (1) the amount of shade over Miller Creek, (2) LWD recruitment, and (3) colonization of native trees.</p> <p>Native trees and shrubs will be planted to increase (1) the amount of shade over Miller Creek, (2) LWD recruitment, and (3) colonization of native trees.</p>                                                                                                                                                                                                                                                                                                                                                                                                                                                                                                                                                                                                                                                                                                                                                                                                                                                                                                                                                                                                                                                            |
| No enhancement action needed.                                                          | <p>These areas either (1) contain well-vegetated buffer that does not require enhancement activities, or (2) are inaccessible or cannot be enhanced without causing harm to desirable vegetation.</p>                                                                                                                                                                                                                                                                                                                                                                                                                                                                                                                                                                                                                                                                                                                                                                                                                                                                                                                                                                                                                                                                                                                                                                                        |

**Table 5.2-3. Final performance standards, evaluation approach, and contingency measures for wetland and buffer enhancement along Miller Creek.**

| Design Criteria                                                                                                                                                                                                                                                                                                                                       | Performance Standard                                                                                                                                                                                                                                                                                                                                                                                                                                                                                                                                                                                                                                                                                                                                    | Evaluation Approach                                                                                                                                         | Contingency Measures                                                                                                                                                                                                                                                                                                                  |
|-------------------------------------------------------------------------------------------------------------------------------------------------------------------------------------------------------------------------------------------------------------------------------------------------------------------------------------------------------|---------------------------------------------------------------------------------------------------------------------------------------------------------------------------------------------------------------------------------------------------------------------------------------------------------------------------------------------------------------------------------------------------------------------------------------------------------------------------------------------------------------------------------------------------------------------------------------------------------------------------------------------------------------------------------------------------------------------------------------------------------|-------------------------------------------------------------------------------------------------------------------------------------------------------------|---------------------------------------------------------------------------------------------------------------------------------------------------------------------------------------------------------------------------------------------------------------------------------------------------------------------------------------|
| <p>1. Riparian buffer areas that are cleared or disturbed during demolition will be planted with native forested and shrub vegetation (these are shaded on the Landscape Plan sheets in Appendix B). Plant native tree species at densities of greater than 280 per acre. Plant native shrub species at densities of greater than 2,100 per acre.</p> | <p>Plant survival will be 100% following year 1. Average survival of planted stock will be at least 80% during the first 3 monitoring years. Tree density will be at least 280 stems/acre; shrub density will be at least 2,100 individuals per acre in monitoring years 3, 8, and 15. During monitoring years 3, 8, and 15, plant diversity will not decrease by more than 10% from the number of plant species installed at baseline. Cover of native species will be at least 80% at monitoring year 15<sup>a</sup>. Cover of non-native, invasive<sup>b</sup> species in newly planted or enhanced areas will not exceed 10% in any monitoring year (see the Landscape Plan sheets in Appendix B for locations where this standard will apply).</p> | <p>Vegetation sampling (plots, transects, or plotless techniques) to estimate native species cover, density, and mortality, and invasive species cover.</p> | <p>If standards are not met:</p> <ul style="list-style-type: none"> <li>• Select species that are better adapted to existing hydrologic conditions.</li> <li>• Install additional plant material.</li> <li>• Install protective collars to reduce herbivore damage.</li> <li>• Control/reduce non-native invasive species.</li> </ul> |
| <p>2. Lawn and other areas dominated by non-native plant species, will be enhanced by planting native forested vegetation.</p>                                                                                                                                                                                                                        | <p>Plant survival will be 100% following year 1. Average survival of planted stock will be at least 80% during the first 3 monitoring years. Tree density will be at least 280 stems/acre; shrub density will be at least 2,100 individuals per acre in monitoring years 3, 8, and 15. In monitoring years 3, 8, and 15, plant diversity will not decrease by more than 10% from the number of plant species installed at baseline. Cover of native species will be at least 80% at monitoring year 15<sup>a</sup>. Cover of non-native, invasive<sup>b</sup> species in newly planted or enhanced areas will not exceed 10% in any monitoring year (see the Landscape Plan sheets in Appendix B for locations where this standard will apply).</p>     | <p>See above.</p>                                                                                                                                           | <p>See above.</p>                                                                                                                                                                                                                                                                                                                     |

**Table 5.2-3. Final performance standards, evaluation approach, and contingency measures for wetland and buffer enhancement along Miller Creek (continued).**

| Design Criteria                                                                                                                                                          | Performance Standard                                                                                                                                                               | Evaluation Approach                                            | Contingency Measures                                      |
|--------------------------------------------------------------------------------------------------------------------------------------------------------------------------|------------------------------------------------------------------------------------------------------------------------------------------------------------------------------------|----------------------------------------------------------------|-----------------------------------------------------------|
| <p>3. Densely plant the portion of the buffer adjacent to Miller Creek with native trees and shrubs where applicable to provide future sources of LWD to the stream.</p> | <p>newly planted or enhanced areas will not exceed 10% in any monitoring year.<br/>Density of trees in buffer is at least 280 stems/acre during monitoring years 3, 8, and 15.</p> | <p>See above.</p>                                              | <p>See above.</p>                                         |
| <p>4. Install fencing and signs to designate the buffer area as a protected mitigation site.</p>                                                                         | <p>Signs and/or fencing will clearly mark the buffer edge as a protected mitigation site (see Appendix 0 for fencing specifications).</p>                                          | <p>Check signs and fencing during annual monitoring visits</p> | <p>Repair and/or re-install damaged or missing signs.</p> |

<sup>a</sup> See Table 4.2-1 for interim cover targets (i.e., from year 3 to year 15).

<sup>b</sup> See Table 4.2-2 for list of invasive, non-native species to be monitored and controlled on the mitigation site.

### **Removal of Structures and Impervious Surfaces**

All structures, underground storage tanks and septic systems, roads, and driveways within the proposed buffer along the Miller Creek riparian corridor will be demolished and removed. If abandoned underground pipes or other structures do not pose risks to water quality, they may be left plugged and in place.

Demolition will be designed to minimize disturbance to existing native vegetation and soils. The contractor responsible for demolition of structures within the stream buffer areas will follow BMPs to prevent erosion and sedimentation to the stream. The Port has already demolished many residential structures within the stream buffer using sediment and erosion control BMPs to prevent erosion and sedimentation to the stream or wetlands. Standard practice prior to any demolition activity is to install an orange barrier fence and a sediment fence between the demolition site and any wetland or water feature. These standard BMPs will continue to be used throughout the demolition activities associated with the Miller Creek buffer enhancement plan. Materials removed from the buffer area during demolition will be disposed of off-site at an approved upland disposal facility.

### **Grading and/or Clearing**

Grading activities will include removing existing structures, fill material, and driveways in the designated buffer areas. Additional minor grading will remove landscape features such as retaining walls. Clearing of large patches of non-native invasive species from accessible areas along the stream is proposed. On parcels where large areas of blackberry or other invasive species will be removed (such as Parcels 255, 256, and 260), the top 6 to 12 inches of topsoil may be tilled and removed if necessary to remove the root stocks of invasive species.

### **Expected Hydrology**

The hydrologic regime within the buffer area along Miller Creek varies widely because of topography, soil conditions, and proximity to the stream or associated wetlands. Surface grades will be changed as little as possible to retain existing drainage and flow patterns. Therefore, no changes to the existing hydrologic regime are anticipated to occur from implementing this mitigation plan.

### **Hazard Wildlife Considerations**

A landscape planting approach has been developed consistent with the WHMP to aid in deterring flocking birds, raptors, and waterfowl from using the buffer areas along Miller Creek as habitat. Mitigation actions in the buffer, such as replacing the existing open areas (i.e., lawns) along the stream with forested and shrub vegetation, will reduce hazard wildlife attractants by covering and screening open water.

To deter raptor use of the mitigation sites, deciduous and coniferous trees with stiff branches (such as Sitka spruce or Douglas fir) will be planted in limited quantities to limit roosting habitat for raptors such as red-tailed hawks. The primary coniferous tree species used in the upland and transitional zones will be western redcedar because its limp branches do not provide ideal raptor perching habitat.

## **Landscape Plan**

Specific planting plans for each area within the buffer have been designed using the buffer area inventory and the four enhancement alternatives (see Table 5.2-2). Plant communities and specific planting zones are shown in detail on Landscape Plan sheets in Appendix B.

A list of plant species similar to that identified for the Miller Creek floodplain and wetland restoration (see Table 5.1-12) will be used in the Miller Creek riparian corridor buffer enhancement plan. Sun-tolerant species such as Douglas fir and red alder will be planted in open sunny areas, while species that prefer shade, such as vine maple, will be planted in shady areas under existing vegetation. A typical planting plan (Figure 5.2-3) depicts how these planting approaches will be applied.

The landscape plan for the area shows that the planting of conifer trees is phased (see Landscape Plan sheets in Appendix B). It is anticipated that these conifers would be planted in a second planting phase coincident with replacement plantings that may be required to meet the year three performance standard for plant survival. At this time, the conifer species would be planted. The trees will be positioned such that they receive some shade from adjacent plants (trees, shrubs, and groundcover). For the first growing season following this planting, soil moisture conditions will be examined closely, and the use of the temporary irrigation system may be used to reduce mortality and promote growth.

A temporary irrigation system will be provided within the buffer areas. Irrigation will be used only during the plant establishment phase and will be removed after plant survival standards have been met. Irrigation will likely be used during the June through September time period, depending on weather conditions. Application rates are planned to be less than agronomic rates, but sufficient to reduce plant mortality and promote plant growth during the first season following planting.

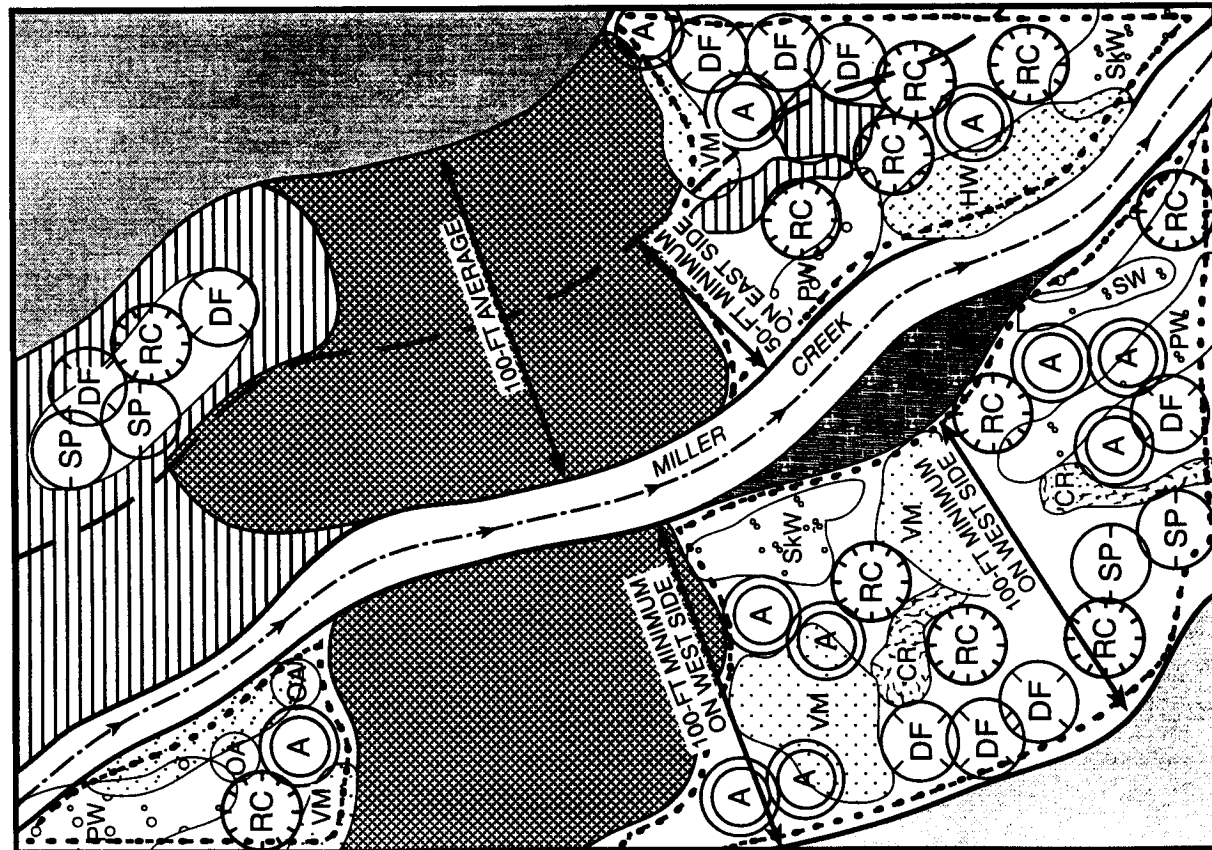
### **5.2.1.8 Implementation**

Miller Creek buffer projects will be closely coordinated with the instream enhancement projects, as well as related Master Plan Update improvements, such as construction of the embankment. Construction methods, sequencing, and steps necessary to implement both the riparian wetland and buffer enhancement projects and the instream enhancement projects are discussed in Section 5.2.2.10.

### **5.2.1.9 Monitoring and Performance Standards**

Monitoring of the wetland and riparian buffer projects will be consistent with the monitoring approach and schedule outlined in Section 4. Specific performance standards will be evaluated regularly during the monitoring period to ensure that the wetland and riparian buffer enhancement projects are meeting project goals and objectives (see Table 5.2-3). If performance standards are not met, specific contingency measures listed in Table 5.2-3 may be implemented, following the adaptive management approach described in Section 4. Monitoring schedules specific to the riparian buffer are provided in Table 5.2-4.



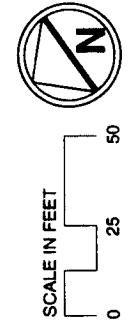


- Existing Wetland
- Existing vegetation to remain
- Area of existing non-native invasive plant species to be removed and replaced with native riparian trees and shrubs
- Areas for partial non-native plant removal. Native coniferous trees will be planted to provide shading

| Riparian Floodplain Zone               | Upland Zone         |
|----------------------------------------|---------------------|
| <b>TREES</b>                           | <b>TREES</b>        |
| RC Western Redcedar                    | DF Douglas Fir      |
| A Red Alder                            | SP Sitka Spruce     |
| OA Oregon Ash                          | FC Western Redcedar |
| <b>SHRUBS</b>                          | A Red Alder         |
| SkW Sitka Willow                       | <b>SHRUBS</b>       |
| PW Pacific Willow                      | VM Vine Maple       |
| HW Hooker's Willow                     | CR Clustered Rose   |
| Hydroseed Mix/<br>Natural Colonization |                     |

Port of Seattle/Natural Resource Mitigation Plan/556-2812-001/01(03) 11/01 (K)

**Figure 5.2-3  
Typical Planting Plan  
for the Miller Creek Upland and  
Streamside Buffer Planting Zones**



**Table 5.2-4. Monitoring schedule for the Miller Creek buffer and wetland enhancement project.**

| Feature                      | Method                                                                                   | Duration                         | Data Collection Year |   |   |   |   |   |    |    |    |   |   |   |   |   |   |
|------------------------------|------------------------------------------------------------------------------------------|----------------------------------|----------------------|---|---|---|---|---|----|----|----|---|---|---|---|---|---|
|                              |                                                                                          |                                  | 0                    | 1 | 2 | 3 | 5 | 7 | 10 | 12 | 15 |   |   |   |   |   |   |
| Plant survival               | Calculating plant survival.                                                              | Once late spring to early summer | X                    | X | X | X | X |   |    |    |    |   |   |   |   |   |   |
| Tree and shrub density/cover | Vegetation sampling                                                                      | Once late spring to early summer | X                    | X | X | X | X | X | X  | X  | X  | X | X | X | X | X | X |
| Vegetation structure         | Describe from walk-through surveys, incorporating data from above analysis as available. | Once late spring to early summer | X                    | X | X | X | X | X | X  | X  | X  | X | X | X | X | X | X |
| Reports                      |                                                                                          |                                  | X                    | X | X | X | X | X | X  | X  | X  | X | X | X | X | X | X |

In areas where enhancement tree plantings are added to existing forest vegetation, tree densities of at least 280 trees per acre will be achieved. In these areas, survival of new plants will be monitored for the appropriate performance standards. If mortality of existing vegetation occurs (i.e., through windfall or other damage, they will be evaluated and using adaptive management analysis, replacement planting may be used to supplement these areas.

#### **5.2.1.10 Site Protection**

The Port will execute and file a restrictive covenant for the mitigation area. Copies of proposed restrictive covenants are included in Appendix F.

The boundaries of the mitigation area and buffers shall be permanently marked with stakes at least every 100 feet or with fencing. The marking shall include signage that clearly indicates that mowing and fertilizer/pesticide applications are prohibited within mitigation areas. The details of fencing and signage are provided in Appendix P.

#### **5.2.1.11 Maintenance and Contingency Plans**

Routine maintenance tasks (e.g., maintaining irrigation system, removing trash) and adaptive management/contingency measures (e.g., weed management, replacing plants) will be implemented consistent with the approach outlined in Section 4. Specific contingency actions for each wetland and riparian buffer performance standard are provided in Table 5.2-3.

### **5.2.2 Miller Creek Instream Habitat Enhancement Plan**

Four major instream enhancement projects, as well as general instream habitat enhancements, will restore and improve the quality of fish habitat in Miller Creek. Instream habitat quality is currently degraded as a result of historic residential land uses and overall urbanization in the basin (see Section 2).

The section of Miller Creek between the Vacca Farm site and Des Moines Memorial Drive was surveyed in February and March 1999 to identify areas within the stream channel that would benefit from habitat enhancement. As a result of this survey, four enhancement projects have been identified (Appendix B, Sheet C2). Habitat enhancement in these four projects includes removal of channel armoring, weirs, concrete walls, and footbridges, and installing instream features such as root wads, gravel, and LWD. In addition to these four instream enhancement projects, LWD will be added at selected locations along the 6,500-ft section of Miller Creek to enhance overall channel function and habitat (Appendix B, Sheets C7 and C10). Instream enhancement projects will be coordinated with the wetland and riparian buffer enhancement projects. The streambed and bank of Miller Creek adjacent to the South 156th Way bridge will also be restored after the existing bridge over South 156th Way is removed and reconstructed as part of relocating South 154<sup>th</sup> Street (see Figure 5.2-1).

**5.2.2.1 Goals, Objectives, and Design Criteria**

The overall goal of the Miller Creek instream enhancement projects is to alleviate historic human disturbances by increasing the amount, quality, and continuity of instream fish habitat. Specific design objectives in the instream enhancement projects are:

- Enhance instream fish habitat by increasing channel complexity
- Stabilize bed and bank erosion along Miller Creek
- Remove instream man-made debris and channel armoring
- Enhance instream substrate conditions for fish and invertebrates
- Restore the streambed and bank after relocating the bridge over South 156th Way

To implement the goal identified above, specific objectives and design criteria were developed (Table 5.2-5).

**Table 5.2-5. Mitigation goals, design objectives, and design criteria for instream enhancement projects in Miller Creek.**

| <b>Goals and Design Objectives</b>                                                     | <b>Design Criteria</b>                                                                                  |
|----------------------------------------------------------------------------------------|---------------------------------------------------------------------------------------------------------|
| <b>Goal 1: Enhance habitat by increasing channel complexity</b>                        |                                                                                                         |
| Create pools and riffle habitat.                                                       | Remove cemented riprap along banks, encourage natural formation of meander bends and cut benches.       |
| Create habitat features for juvenile rearing and high-flow refugia.                    | Increase the amount of stable, LWD in the channel.                                                      |
| Create instream diversity and enhance organic matter retention.                        | Place wood in stream to create flow diversity and refugia.                                              |
| <b>Goal 2: Stabilize bed and bank erosion</b>                                          |                                                                                                         |
| Identify locations of in-channel or bank erosion and stabilize those areas.            | Stabilize those areas of excessive erosion by using native vegetation and LWD.                          |
| <b>Goal 3: Remove trash</b>                                                            |                                                                                                         |
| Channel will be free of trash.                                                         | Remove all trash from the channel that could be harmful to fish habitat, aesthetics, and water quality. |
| <b>Goal 4: Enhance instream substrate</b>                                              |                                                                                                         |
| Enhance substrate.                                                                     | Add gravel to degraded reaches where natural recruitment is limited.                                    |
| <b>Goal 5: Restore the bed and bank after relocating the bridge at South 156th Way</b> |                                                                                                         |
| Reduce fine sediment load from Port property.                                          | Reduce upstream erosion by vegetating banks and replanting the Vacca Farm site.                         |

### **5.2.2.2 Mitigation Site Description**

The four instream enhancement projects and the general habitat enhancements are located in Miller Creek between the Vacca Farm site and Des Moines Memorial Drive (see Figure 5.2-1; Appendix B, Sheet C2).

Between Vacca Farm and South 160<sup>th</sup> Street, the stream channel is less altered than the ditched and channelized reach on the Vacca Farm site; however, it still suffers from the effects of urbanization. South of Vacca Farm, the stream contains some meanders, pools and riffles, and LWD in the channel. The substrate is predominantly silty, mixed with areas of sand and till in the northern portions of this reach. Farther downstream the substrate consists largely of gravel and gravel-sand bars. Unconfined channel widths in this reach range from 7 to 10 ft and gravel bars are approximately 5 ft wide. Because this stream reach has been surrounded by residences and yards, several stream portions are modified with riprap, retaining walls, bridge abutments, footbridges, and other bank-side structures that restrict natural channel morphology. The vegetated upland buffer in this area mostly consists of lawn and some bushes and trees planted by homeowners, but there is very little native riparian vegetation.

The stream channel between South 160<sup>th</sup> Street and SR 509 is less disturbed than the upstream reaches, with channel widths ranging from 7 to 10 ft. With the exception of a few small stretches within this reach, which have been highly modified with riprap, tire walls, or fences, this reach is characterized by meanders, LWD jams, riparian vegetation (although in much of the area the vegetation is non-native), pools and riffles, and gravel bars. In this section, residential development is generally located farther from the stream than in the upstream reaches. As a result, the stream-banks have more intact riparian vegetation, reducing the impact of urbanization. Gravel and sandbars are present in many portions of this reach and substrate in the majority of the channel is gravel.

### **5.2.2.3 Ownership**

The Port owns the entire area to be included in the Miller Creek riparian and instream enhancement mitigation.

### **5.2.2.4 Rationale for Selection**

Mitigation sites for the specific instream enhancement projects were selected based on several criteria. An initial survey of existing conditions was conducted to identify locations where development adjacent to the channel or alterations to the channel were directly impairing habitat and/or water quality in Miller Creek. These sites were then evaluated based on the severity and type of impact and opportunity for restoration. Type of impact included the loss of habitat complexity, channel armoring, erosion, man-made debris in the channel, and unstable or uniform geomorphology. Opportunities for significant improvement at potential enhancement sites were determined based on benefits to upstream and downstream reaches, access to the site, coordination with buffer revegetation projects, and potential negative impacts during construction.

### 5.2.2.5 Constraints

There are no significant constraints to the implementing the mitigation projects. However, instream work must be performed during low-flow periods, and all work will be designed and performed consistent with conditions of the HPA permit for the projects.

### 5.2.2.6 Ecological Assessment of the Enhancement Sites

Urban development in the Miller Creek watershed has degraded instream habitat and water quality throughout the basin. Specifically, within the project reach, aquatic habitat has been degraded by altered hydrology; channelization; excess fine sediments; altered water quality due to inputs of pollutants, stormwater discharges, and agricultural and residential herbicides, pesticides, and fertilizers; loss of habitat complexity; and loss of contiguous vegetated buffers (Table 5.2-6). However, Miller Creek continues to support populations of coho salmon, anadromous and resident cutthroat trout, three-spine sticklebacks, white crappie (*Pomoxis annularis*), and pumpkinseed sunfish.

**Table 5.2-6. Summary of existing conditions in Miller Creek between South 156th Way and Des Moines Memorial Drive.**

| Parameter             | Description                                                                                                                                                                                                                                     |
|-----------------------|-------------------------------------------------------------------------------------------------------------------------------------------------------------------------------------------------------------------------------------------------|
| Fish Habitat          | Pool habitat and high-flow refugia quality are relatively poor, which is related to the lack of LWD in the channel. This problem (and other factors) may limit the sizes of resident and anadromous fish populations supported by Miller Creek. |
| Fine Sediment         | High turbidity was observed (and reported) in Miller Creek during winter base flow rates. This problem is primarily found in the upper reaches, where the channel has been straightened and confined by riprap on both banks.                   |
| Geomorphic Complexity | Numerous footbridges and riprap confine the stream to a narrow straight channel in many reaches.                                                                                                                                                |
| Man-made Debris       | Man-made debris (tires, shopping carts, metal pipes, and car parts) and fences that restrict upstream and downstream fish movement are common throughout the stream.                                                                            |

Between South 156th Way and the South 160<sup>th</sup> Street culvert, Miller Creek has been degraded by substantial development adjacent to the banks. Segments of the stream have been straightened and the banks in these reaches are lined with riprap or cement. Substrate in this reach consists of silt and fine sands. Numerous footbridges and weirs influence channel morphology and reduce habitat complexity. Most of the footbridges confine the channel, creating straightened reaches of high-velocity flows and bed scouring. Riparian vegetation consists primarily of lawn and some trees adjacent to the channel; however, the vegetation does not provide shade, bank stabilization, or habitat complexity. A fish survey conducted in 1998 found that sticklebacks were the dominant fish in this reach; white crappies were also found. Although cutthroat trout were found upstream of the waterfall north of South 160<sup>th</sup> Street during an electroshocking fish survey on November 10, 1998 (Parametrix 1998), they were not found during that survey in the upper reaches of Miller Creek north of South 156th Way.

Specific conditions in each of the four instream project reaches are described in the following section.

### **Instream Enhancement Project 1**

Instream Project 1 is located between the downstream end of the Miller Creek relocation project and South 156th Way (see Figure 5.2-1). The project area includes approximately 650 ft of Miller Creek, which is confined along most of the project length by riprap (Figure 5.2-4). Historically, this area was a wetland that may have lacked a defined streambed. When this area was drained for farmland, Miller Creek was channelized along the eastern edge of Wetland A1. A small side channel, or ditch, draining Wetland A1 flows into Miller Creek at the south end of the wetland (see Figure 5.2-4). This project is located on Parcels 63, 87, 88, 89, 90, 91, 97, 98, 100, and 101.

In this reach Miller Creek is a low-gradient stream, although the valley becomes more confined downstream of the confluence with the side channel. The project site has two distinct areas: upstream of the confluence with the side channel (Parcels 88, 89, and 90), and downstream of the confluence where the valley narrows (Parcels 91, 99, 100, and 101). Substrate in the upstream reach is composed primarily of silt and fine gravel; however, some coarse gravel exists where riprap has fallen into the channel and created a riffle. Substrate in the side channel and downstream of the confluence consists of fine silt. Five footbridges cross Miller Creek upstream of the confluence, and a fence crosses the channel at the upstream end of the project site. Two footbridges and a fence cross the side channel.

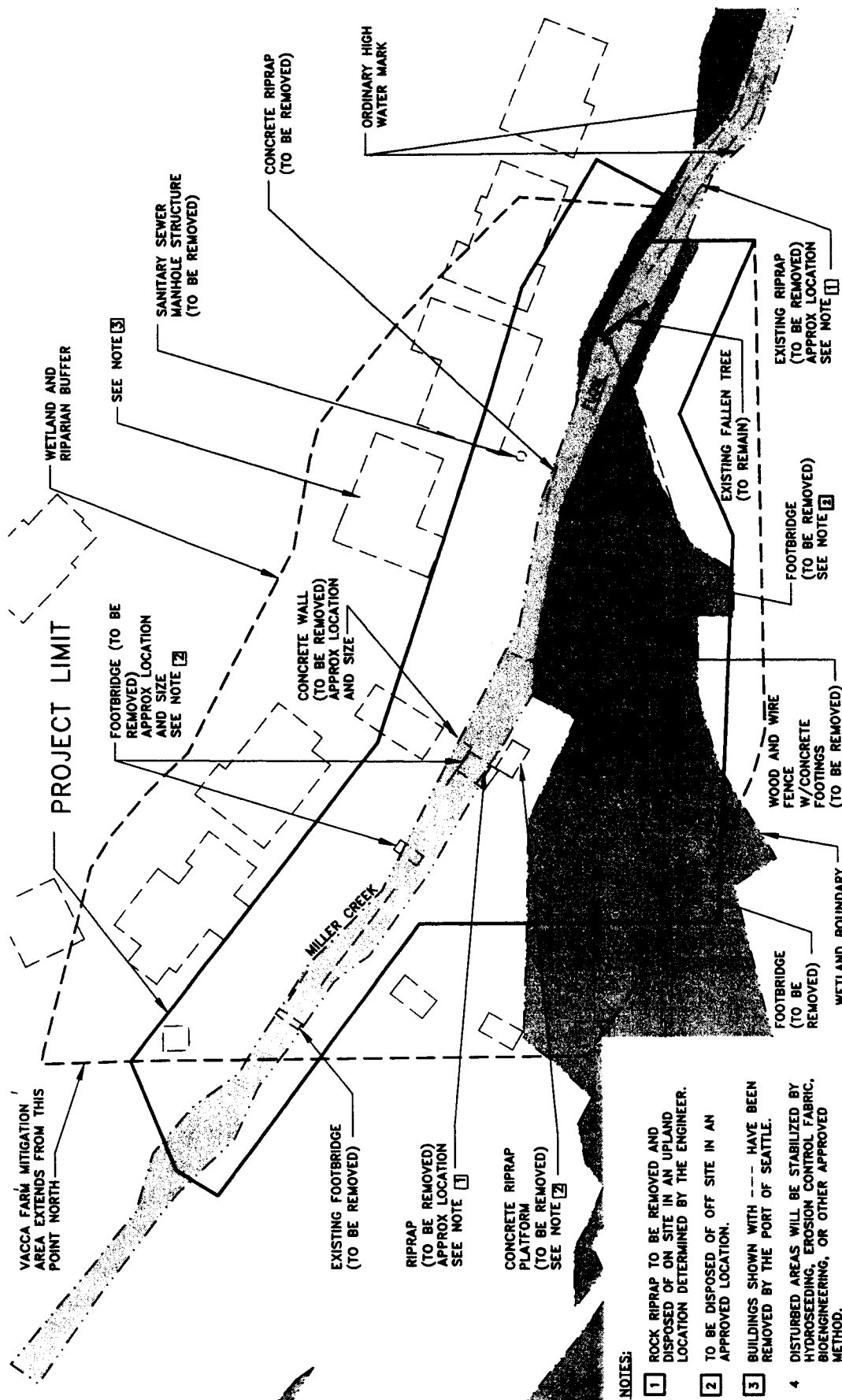
During high-flow events, both Miller Creek and the side channel overtop their banks and flood the adjacent wetland. Vegetation within this reach is predominantly grass; the site also has several large western redcedar trees and some non-native and invasive species. Downstream of the confluence several large trees are located along the channel; however, the remainder of vegetation is lawn and invasive or exotic species.

### **Instream Enhancement Project 2**

Instream Project 2 is located approximately 150 ft upstream of South 160<sup>th</sup> Street (see Figure 5.2-1). A narrow ravine confines Miller Creek and its floodplain throughout this reach.

Construction of two weirs in this reach has altered the channel profile and resulted in a uniform channel with little habitat diversity (Figure 5.2-5). The first (downstream) weir is approximately 3 ft high and constructed of large boulders. The second (upstream) weir is constructed of cement, located approximately 70 ft upstream of the first weir, and is approximately 2 ft high. A footbridge crosses Miller Creek just upstream of the second weir. Miller Creek is confined by riprap on both banks downstream of the first weir and upstream of the second weir. Both weirs may impede fish passage at summer low flows.

Between the weirs, riprap armors the left bank, while lawn on the right bank is planted to the edge of the channel. During storm events, a pool forms behind the downstream weir and floods the right bank. An emergent wetland lies adjacent to the left bank of Miller Creek throughout the project area.



**Figure 5.2-4  
Instream Project 1  
Existing Conditions**

**NOTES:**

- 1 ROCK RIPRAP TO BE REMOVED AND DISPOSED OF ON SITE IN AN UPLAND LOCATION DETERMINED BY THE ENGINEER.
- 2 TO BE DISPOSED OF OFF SITE IN AN APPROVED LOCATION.
- 3 BUILDINGS SHOWN WITH --- HAVE BEEN REMOVED BY THE PORT OF SEATTLE.
- 4 DISTURBED AREAS WILL BE STABILIZED BY HYDROSEEDING, EROSION CONTROL FABRIC, BIOENGINEERING, OR OTHER APPROVED METHOD.

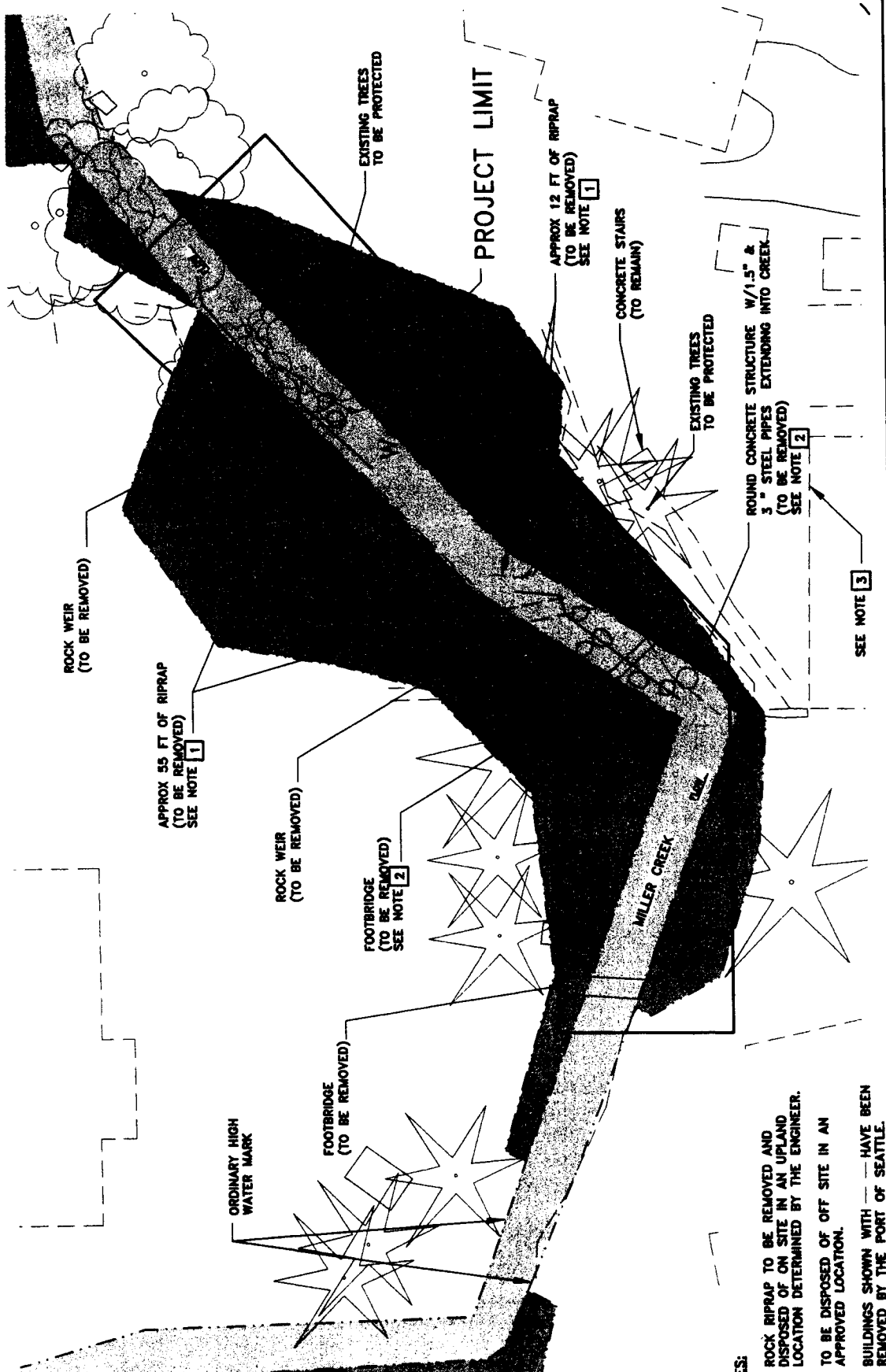
FILE: 291203\_J3  
DATE: 06/05/01



**LEGEND**







**NOTES:**

- 1 ROCK RIPRAP TO BE REMOVED AND DISPOSED OF ON SITE IN AN UPLAND LOCATION DETERMINED BY THE ENGINEER.
- 2 TO BE DISPOSED OF OFF SITE IN AN APPROVED LOCATION.
- 3 BUILDINGS SHOWN WITH --- HAVE BEEN REMOVED BY THE PORT OF SEATTLE.

FILE: 201203.F5  
DATE: 11/15/01



**LEGEND**



**Figure 5.2-5  
Instream Project 2  
Existing Conditions**

Vegetation in the project area is predominantly turf grass lawns; however, a stand of large cottonwood trees is located on the right bank near the downstream weir. The project site is easily accessible on the right bank, although heavy equipment access may be limited by a retaining wall on the left bank.

### **Instream Enhancement Project 3**

The site of Instream Project 3 extends from a scour pool and debris area immediately downstream of a culvert at South 160<sup>th</sup> Street to approximately 600 ft downstream (see Figure 5.2-1). This project is located on Parcels 256, 257, 258, 259, 260, and 276. Miller Creek is confined in the middle and upper portions of this site by a narrow ravine. However, along the lower project reaches, the valley widens and an extensive floodplain and wetland are associated with the stream.

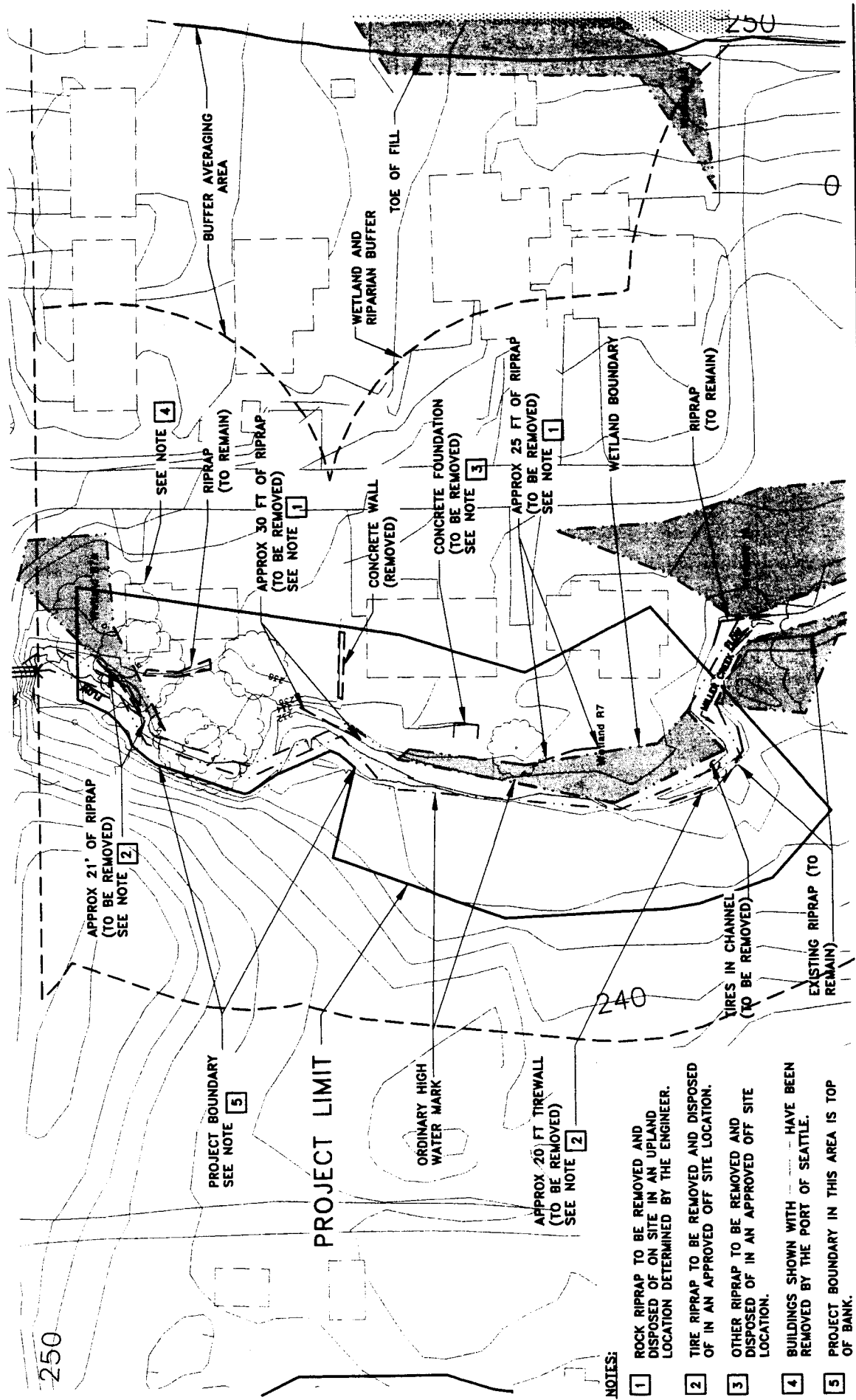
Tire riprap has been placed along the left bank downstream of the scour pool, while the right bank is steep and shows evidence of erosion and downcutting. In the middle of the project site, Miller Creek becomes confined to a narrow channel, the gradient increases to a slope of approximately 3 percent, and the velocity increases. At the lower end of the steep reach, Miller Creek has a sharp meander bend that is protected by riprap (Figure 5.2-6). Tire riprap lines the channel approximately 40 ft upstream of this meander. A deep scour pool with large cobble substrate has formed on the outside edge of the meander. Another meander immediately downstream has also been lined with riprap.

Vegetation throughout this reach is dominated by blackberry species and turf grass lawn, with a few large trees scattered along the banks. Access to the site is limited by steep banks on the right bank immediately downstream of the culvert. However, the project area is easily accessible along the left bank.

### **Instream Enhancement Project 4**


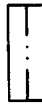
Enhancement Project 4 extends from a point east of 8<sup>th</sup> Avenue South to a private driveway approximately 820 ft upstream (see Figure 5.2-1). Project 4 is located on Parcels 314, 316, 317, and 321. Many reaches of Miller Creek throughout this project area are unconfined by riprap and have pool and riffle sequences; small pieces of in-channel wood are present throughout this reach as well. Riprap lines the bank downstream of the private driveway (Figure 5.2-7). Large cement pieces line Miller Creek on the right bank, constricting the channel. A collapsed footbridge has created a backwater pool and trapped debris on the upstream side during winter base flow conditions. At the downstream portion of the project area, two rock walls line the stream and a fence spans the channel. The upstream wall, located along the left bank, influences the flow pattern of the stream; however, there is evidence of bank erosion downstream of this wall. Miller Creek is channelized by the second wall, which lines both banks.

Riparian vegetation in the project site includes many large (>30 ft) western redcedar and red alder trees; however, little understory exists, and ground cover is primarily grass, gravel, and invasive species such as blackberry. Steep banks at specific locations on the left bank would limit site access. Miller Creek is easily accessible in most places along the right bank.



**Figure 5.2-6  
Instream Project 3  
Existing Conditions**

**LEGEND**

-  WETLAND
-  MILLER CREEK CHANNEL

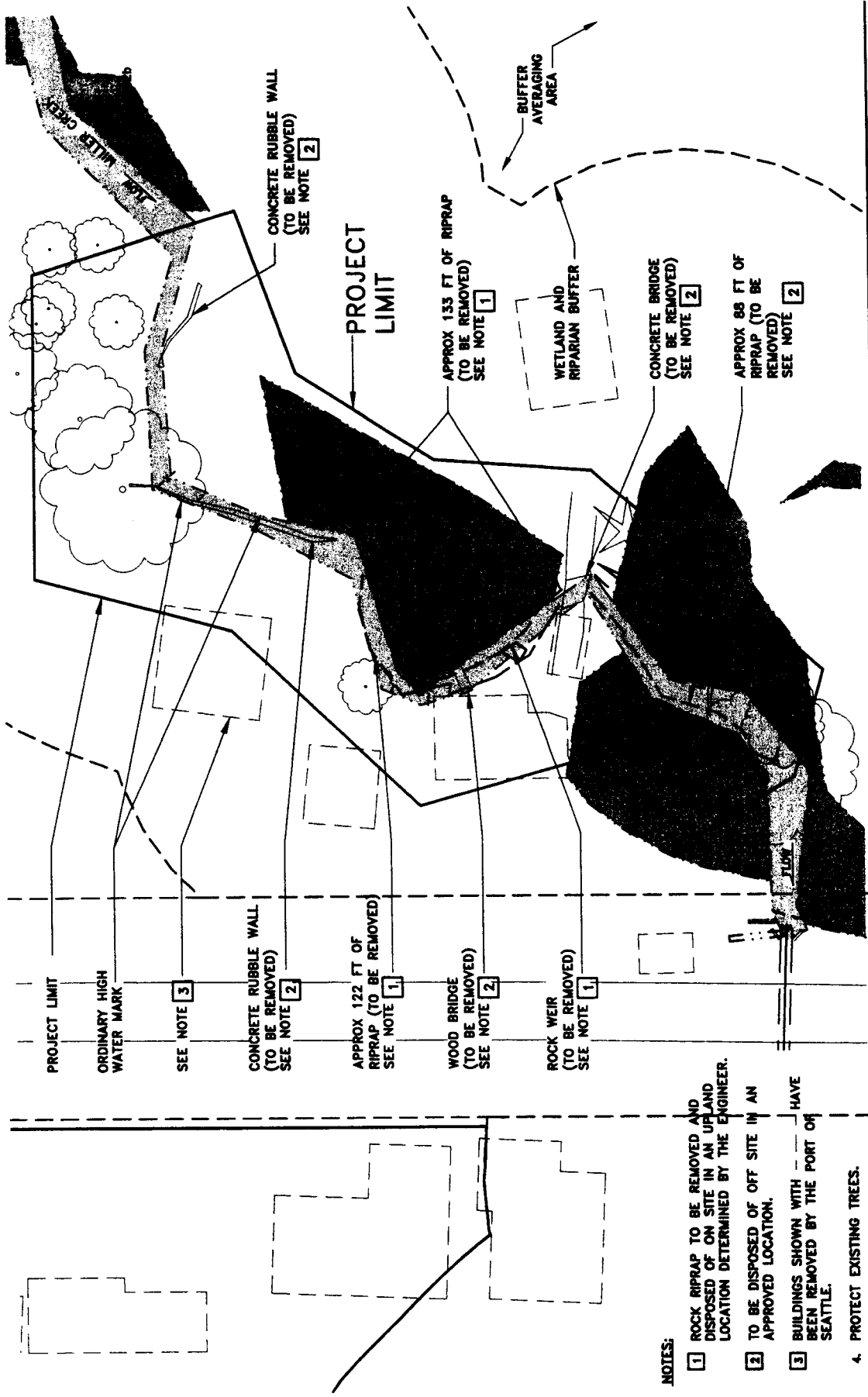
- NOTES:**
- 1 ROCK RIPRAP TO BE REMOVED AND DISPOSED OF ON SITE IN AN UPLAND LOCATION DETERMINED BY THE ENGINEER.
  - 2 TIRE RIPRAP TO BE REMOVED AND DISPOSED OF IN AN APPROVED OFF SITE LOCATION.
  - 3 OTHER RIPRAP TO BE REMOVED AND DISPOSED OF IN AN APPROVED OFF SITE LOCATION.
  - 4 BUILDINGS SHOWN WITH DASHED LINES HAVE BEEN REMOVED BY THE PORT OF SEATTLE.
  - 5 PROJECT BOUNDARY IN THIS AREA IS TOP OF BANK.

FILE: 291703\_15  
DATE: 11/15/01



0 30' 60'  
SCALE IN FEET

**AR 049215**



NOTES:

- 1 ROCK RIPRAP TO BE REMOVED AND DISPOSED OF ON SITE IN AN UPLAND LOCATION DETERMINED BY THE ENGINEER.
- 2 TO BE DISPOSED OF OFF SITE IN AN APPROVED LOCATION.
- 3 BUILDINGS SHOWN WITH \_\_\_\_\_ HAVE BEEN REMOVED BY THE PORT OF SEATTLE.
- 4. PROTECT EXISTING TREES.

FILE: 201003\_05  
DATE: 11/16/01



LEGEND

- WETLAND
- MILLER CREEK CHANNEL

Figure 5.2-7  
Instream Project 4  
Existing Conditions

### 5.2.2.7 Instream Habitat Enhancements Mitigation Design

The following sections describe the mitigation actions proposed for the four specific instream habitat enhancement projects, the general in-stream habitat enhancement along Miller Creek, and the restoration of the stream for the South 156th Way bridge relocation.

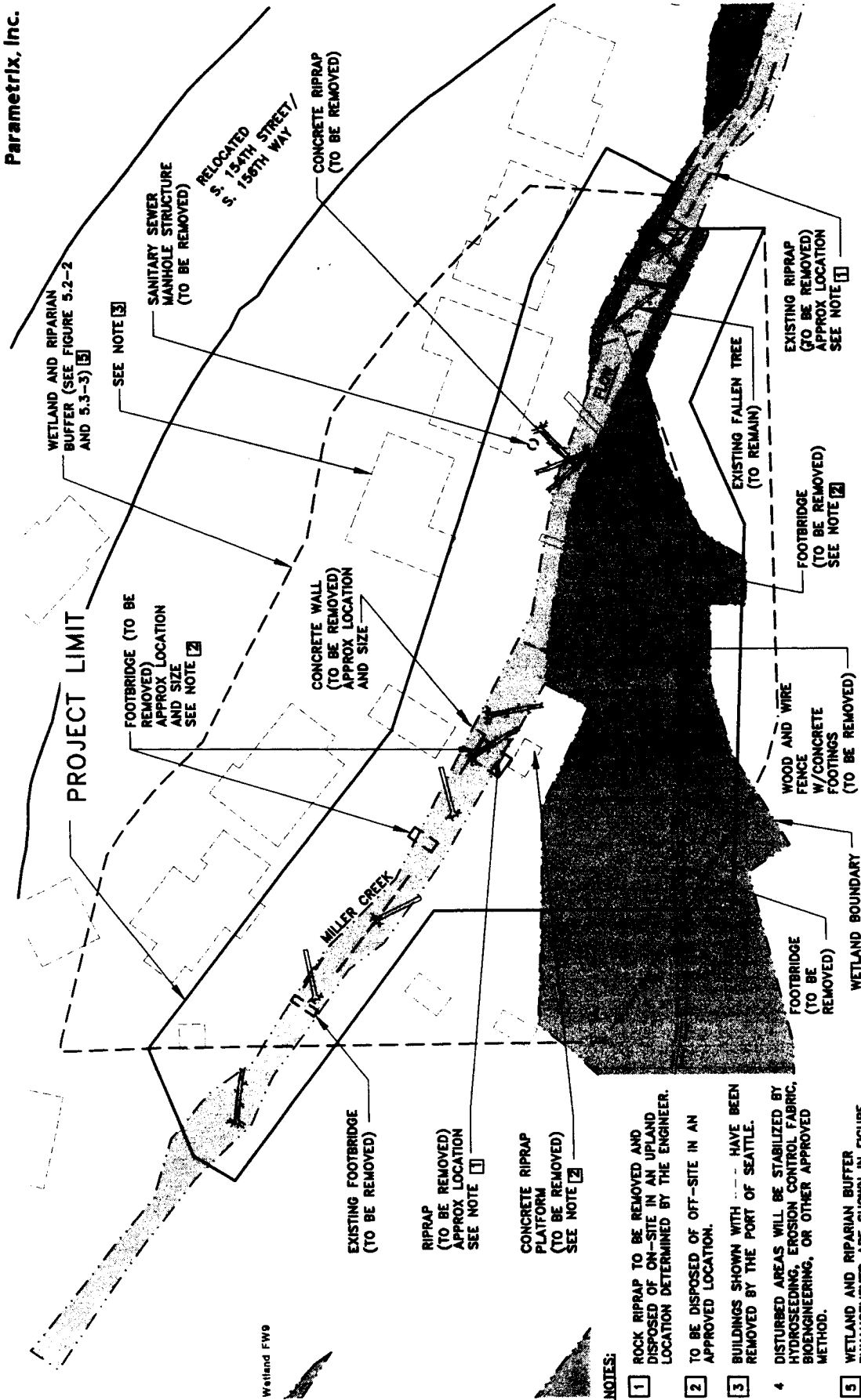
Most channel armoring, rock walls, weirs, and footbridges along this reach of Miller Creek will be removed. For example, the existing rock weirs located at Instream Project 2 will be removed because they impede fish passage. However, at several locations some riprap will be left in the channel to avoid creating significant erosion or construction impacts (Figures 5.2-8 through 5.2-11; Appendix B, Sheets C3 through C6).

Prior to developing the enhancement designs, cross sections were surveyed in three relatively undisturbed reaches in Miller Creek. These cross sections (Figure 5.2-12) are used as reference sites for proposed instream enhancement projects. The geomorphic and habitat benefits associated with each enhancement feature are summarized in Table 5.2-7.

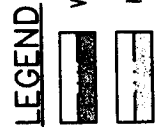
**Table 5.2-7. Habitat and geomorphic benefits of Miller Creek instream enhancement features.**

| <b>Enhancement Feature</b> | <b>Geomorphic Function</b>                                                                                                                            | <b>Habitat Function</b>                                                                                |
|----------------------------|-------------------------------------------------------------------------------------------------------------------------------------------------------|--------------------------------------------------------------------------------------------------------|
| LWD                        | Stabilizes banks<br>Promotes deposition of fine sediment                                                                                              | Increases habitat complexity<br>Promotes pool formation<br>Provides instream cover                     |
| Riparian Vegetation        | Stabilizes banks<br>Provides a source for LWD recruitment<br>Increases roughness, promotes deposition of fine sediment                                | Moderates temperature<br>Provides organic matter<br>Promotes undercut banks<br>Provides instream cover |
| Meander Bends              | Creates pool/riffle sequences<br>Promotes overbank flows, reduces channel incision<br>Creates variations in flow regime<br>Creates depositional areas | Increases habitat complexity<br>Creates spawning reaches                                               |
| Boulders                   | Promotes variation in channel width<br>Creates variations in flow regime                                                                              | Provides instream cover<br>Creates variations in flow regime                                           |
| Erosion Control            | Reduces sediment loading<br>Stabilizes banks                                                                                                          | Reduces spawning habitat degradation<br>Increases macroinvertebrate production                         |
| Remove Instream Barriers   | Promotes natural geomorphic processes (i.e., widening, meandering, deposition)                                                                        | Increases habitat availability/continuity                                                              |
| Debris Removal             | NA                                                                                                                                                    | Enhances aesthetics<br>Reduces potential pollutants                                                    |
| Remove Footbridges/Riprap  | Allows for natural channel movement (i.e., widening, meandering, deposition)                                                                          | Increase habitat complexity                                                                            |

NA = Not applicable



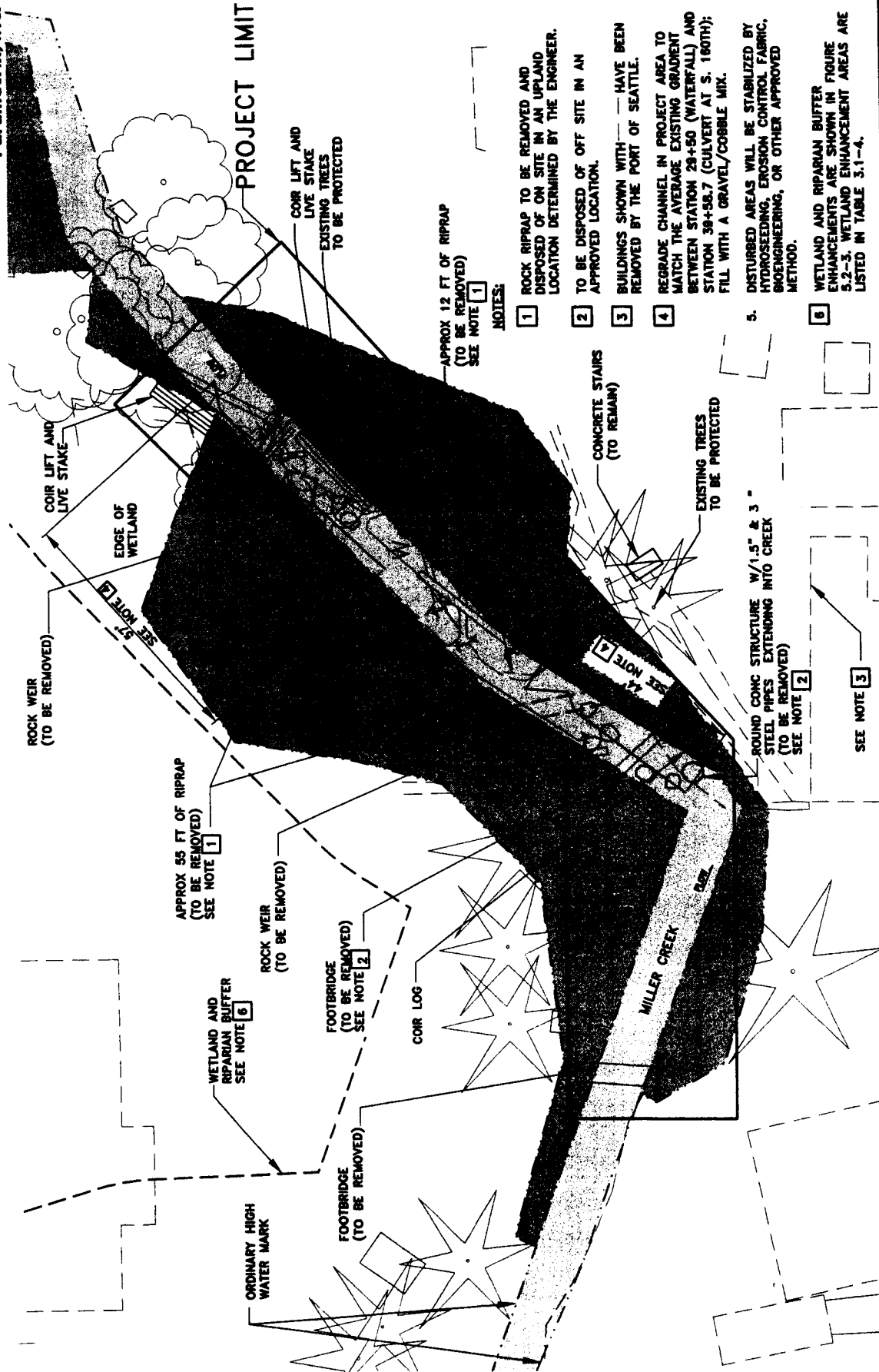
FILE: 281203\_JFS  
DATE: 10/26/01



**Figure 5.2-8  
Instream Project 1  
Proposed Conditions**

- NOTES:**
- 1 ROCK RIPRAP TO BE REMOVED AND DISPOSED OF ON-SITE IN AN UPLAND LOCATION DETERMINED BY THE ENGINEER.
  - 2 TO BE DISPOSED OF OFF-SITE IN AN APPROVED LOCATION.
  - 3 BUILDINGS SHOWN WITH DASHED LINES HAVE BEEN REMOVED BY THE PORT OF SEATTLE.
  - 4 DISTURBED AREAS WILL BE STABILIZED BY HYDROSEEDING, EROSION CONTROL FABRIC, BIOENGINEERING, OR OTHER APPROVED METHOD.
  - 5 WETLAND AND RIPARIAN BUFFER ENHANCEMENTS ARE SHOWN IN FIGURE 5.2-3. WETLAND ENHANCEMENT AREAS ARE LISTED IN TABLE 3.1-4.

Parametrix, Inc.



PROJECT LIMIT

APPROX 12 FT OF RIPRAP (TO BE REMOVED) SEE NOTE 1

APPROX 55 FT OF RIPRAP (TO BE REMOVED) SEE NOTE 1

ROCK WEIR (TO BE REMOVED) SEE NOTE 1

CORR LIFT AND LIVE STAKE

EDGE OF WETLAND

WETLAND AND RIPARIAN BUFFER SEE NOTE 6

ROCK WEIR (TO BE REMOVED)

FOOTBRIDGE (TO BE REMOVED) SEE NOTE 2

CORR LOG

ORDINARY HIGH WATER MARK

FOOTBRIDGE (TO BE REMOVED)

CONCRETE STAIRS (TO REMAIN)

EXISTING TREES TO BE PROTECTED

ROUND CONC STRUCTURE W/1.5" & 3" STEEL PIPES EXTENDING INTO CREEK (TO BE REMOVED) SEE NOTE 2

SEE NOTE 3

NOTES:

- 1 ROCK RIPRAP TO BE REMOVED AND DISPOSED OF ON SITE IN AN UPLAND LOCATION DETERMINED BY THE ENGINEER.
- 2 TO BE DISPOSED OF OFF SITE IN AN APPROVED LOCATION.
- 3 BUILDINGS SHOWN WITH --- HAVE BEEN REMOVED BY THE PORT OF SEATTLE.
- 4 REGRADE CHANNEL IN PROJECT AREA TO MATCH THE AVERAGE EXISTING GRADIENT BETWEEN STATION 29+50 (WATERFALL) AND STATION 30+56.7 (CULVERT AT S. 160TH); FILL WITH A GRAVEL/CORBLE MIX.
- 5 DISTURBED AREAS WILL BE STABILIZED BY HYDROSEEDING, EROSION CONTROL FABRIC, BIOENGINEERING, OR OTHER APPROVED METHOD.
- 6 WETLAND AND RIPARIAN BUFFER ENHANCEMENTS ARE SHOWN IN FIGURE 5.2-3. WETLAND ENHANCEMENT AREAS ARE LISTED IN TABLE 3.1-4.

FILE: 281203.J5  
DATE: 09/06/01



LEGEND

- WETLAND
- MILLER CREEK CHANNEL

Figure 5.2-9  
Instream Project 2  
Proposed Conditions

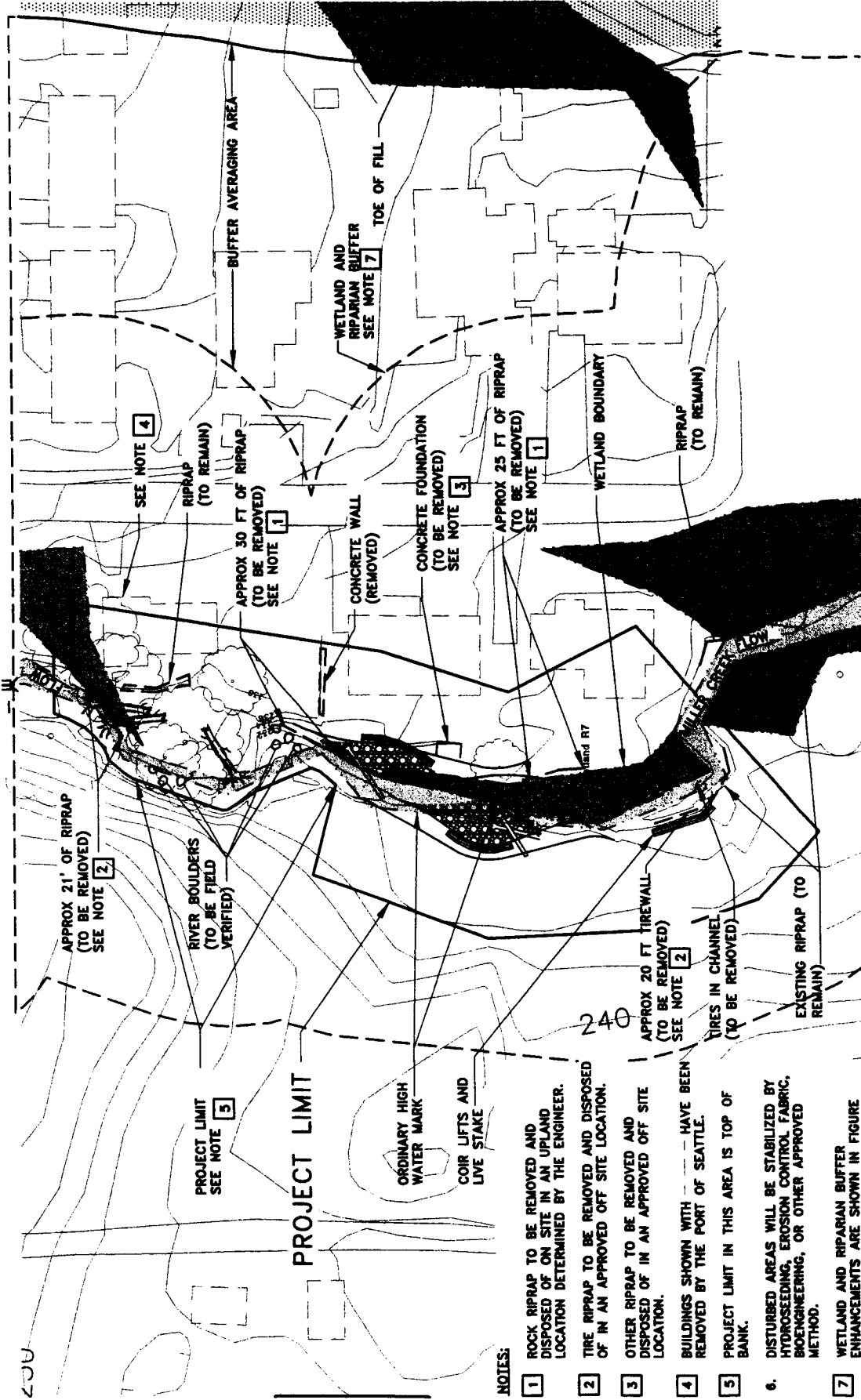
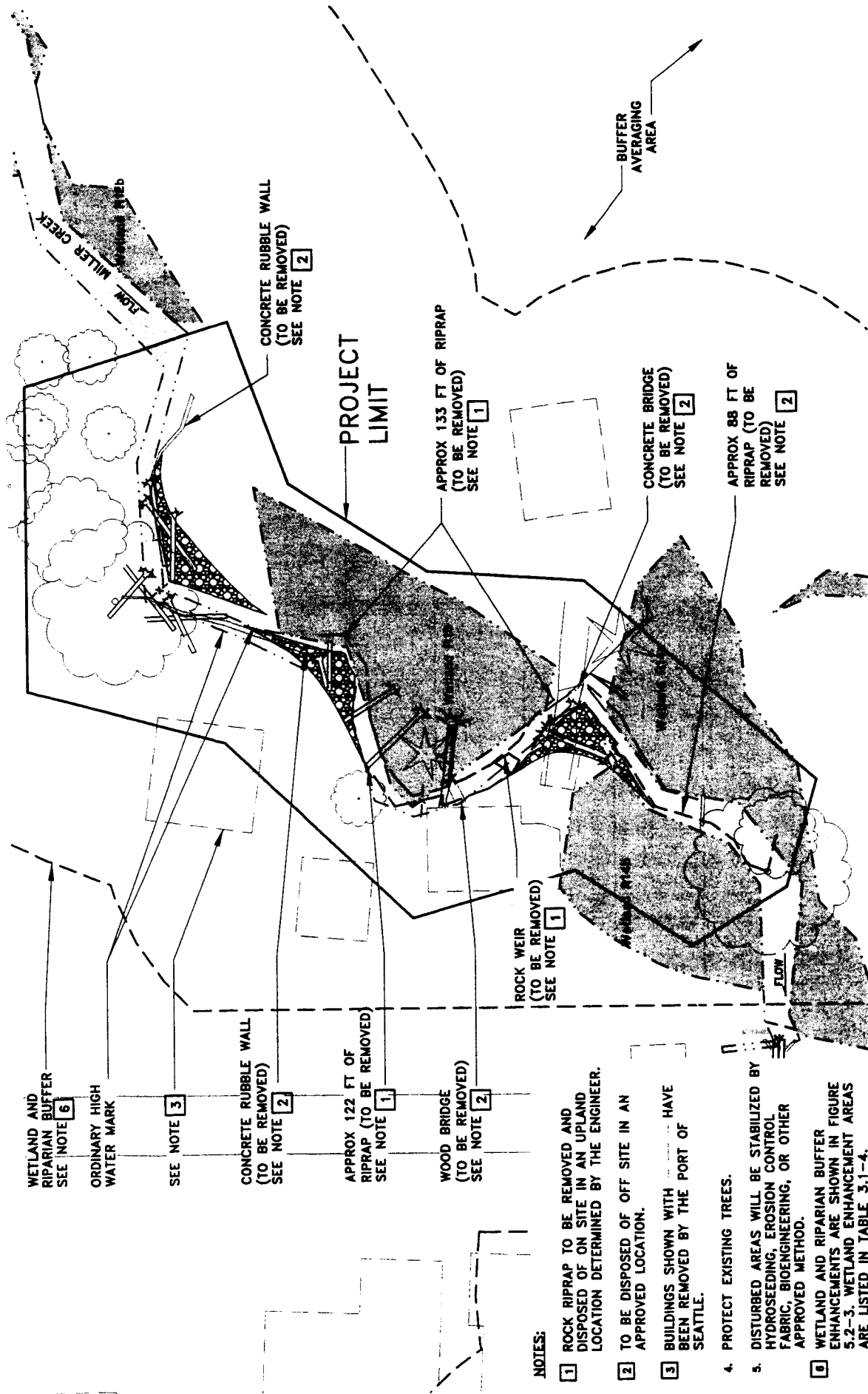


Figure 5.2-10  
 Instream Project 3  
 Proposed Conditions

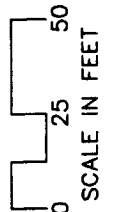




**Figure 5.2-11  
Instream Project 4  
Proposed Conditions**

**LEGEND**

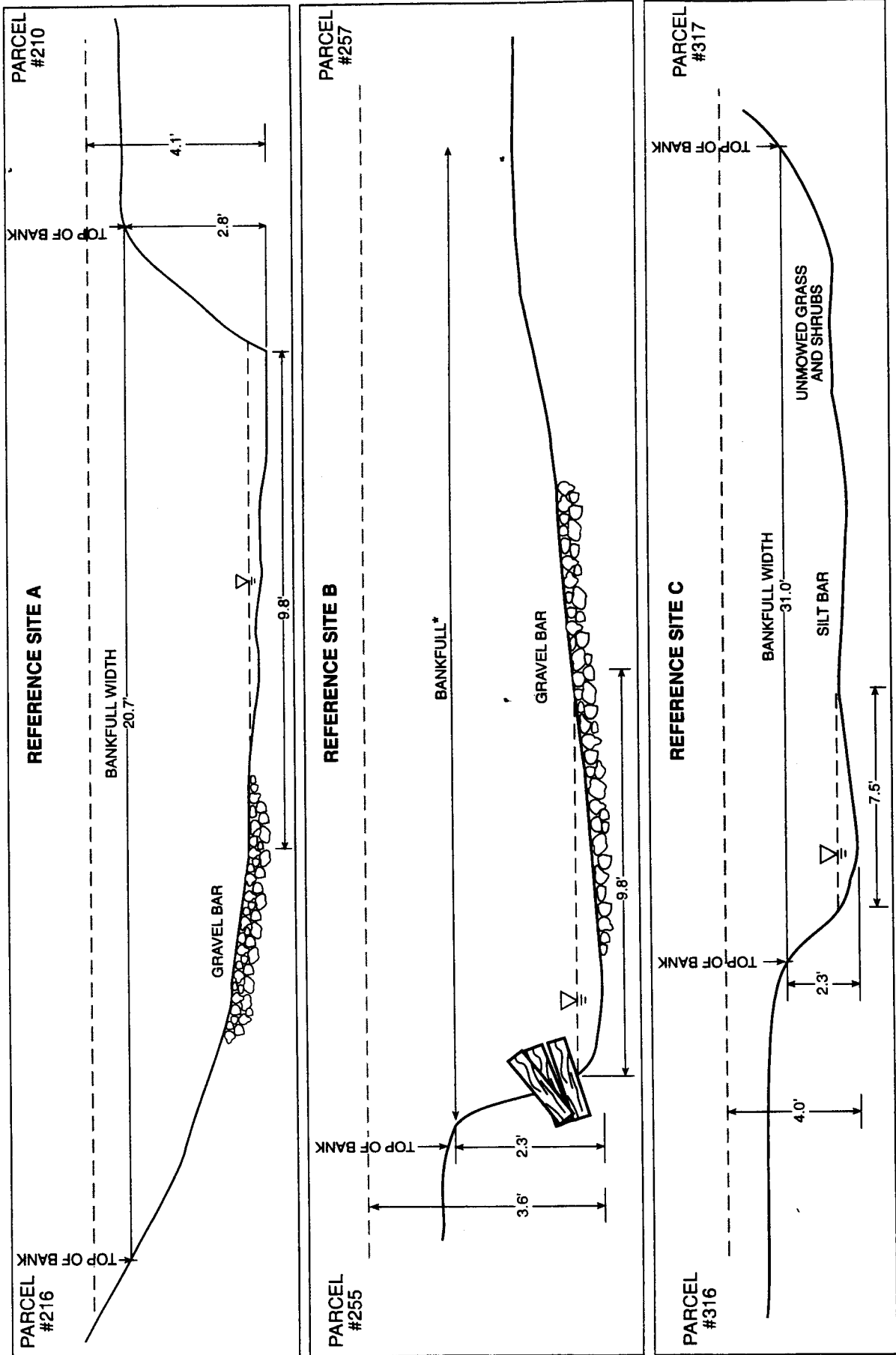
- WETLAND
- MILLER CREEK CHANNEL
- GRAVEL BAR



FILE: 291203.F5  
DATE: 11/16/01

**NOTES:**

- 1 ROCK RIPRAP TO BE REMOVED AND DISPOSED OF ON SITE IN AN UPLAND LOCATION DETERMINED BY THE ENGINEER.
- 2 TO BE DISPOSED OF OFF SITE IN AN APPROVED LOCATION.
- 3 BUILDINGS SHOWN WITH [diagonal hatching] HAVE BEEN REMOVED BY THE PORT OF SEATTLE.
4. PROTECT EXISTING TREES.
5. DISTURBED AREAS WILL BE STABILIZED BY HYDROSEEDING, EROSION CONTROL FABRIC, BIOENGINEERING, OR OTHER APPROVED METHOD.
- 6 WETLAND AND RIPARIAN BUFFER ENHANCEMENTS ARE SHOWN IN FIGURE 5.2-3. WETLAND ENHANCEMENT AREAS ARE LISTED IN TABLE 3.1-4.



**Figure 5.2-12**  
**Representative Cross Sections of Miller Creek**  
**Reference Sites (Surveyed at Parcels 210/216-255/257 and 316/317)**

Port of Seattle/Natural Resource Mitigation Plan 556-2912-001/01(03) 11/01 (K)

- FEMA - 100-year floodplain in elevation
- - - Water surface elevation at winter base flow (4/28/99)
- ▽ Water surface elevation at winter base flow (4/28/99)
- \* Bankfull width not determined for reference site B

NOT TO SCALE

### **Instream Enhancement Project 1**

Activities at Instream Project 1 will enhance approximately 470 ft of Miller Creek and 300 ft of a side channel extending from the Miller Creek relocation and Vacca Farm project to the downstream side of the existing South 156th Way bridge (see Figure 5.2-8; Appendix B, Sheet C3). The primary goal of the enhancement features is to create a geomorphically stable, low-gradient stream. Other goals include increasing the frequency of overbank flow for sediment deposition, enhancing instream habitat, and enhancing the side channel.

Project 1 includes removing riprap, footbridges, railroad ties, and fences along Miller Creek and placing woody debris in the channel to increase instream habitat complexity. Riprap currently located upstream of the South 156th Way bridge will be removed as part of the bridge replacement project. Portions of the area may be regraded to match grading associated with the Vacca Farm project and to promote flooding near the confluence with the side channel. The reach currently located under the existing bridge will be restored by adding some wood and large rocks, providing erosion control along the banks, and replanting the riparian area once this bridge has been replaced.

Addition of woody debris and native vegetation to the main and side channel will create more diverse instream habitat for fish and other aquatic organisms. Native riparian and wetland vegetation will be planted along the banks.

The entire project site is easily accessible to people and heavy equipment on both banks. Therefore, construction of instream enhancement features and replanting of riparian vegetation will be unrestricted. Specific access routes will be identified in the field to protect sensitive areas located within the project boundary.

### **Instream Enhancement Project 2**

Proposed enhancements at Instream Project 2 include removing riprap and the two instream weirs, placing LWD and river boulders in the channel, and replanting with native wetland and riparian vegetation (see Figure 5.2-9; Appendix B, Sheet C4). The goal of this project is to improve fish passage and enhance instream and riparian habitat along approximately 234 ft of Miller Creek. Approximately 100 ft of the channel profile will be regraded to match average upstream and downstream gradients.

Approximately 55 ft of riprap will be removed along the left bank between the two weirs and approximately 12 ft of riprap will be removed along the right bank. All of the riprap associated with the two weirs, as well as the two weirs, will be removed from the stream. Two footbridges will also be removed. Coir logs and coir lifts will be used to restabilize areas where riprap is removed (Appendix B, Sheets C4 and C9). Stream gravel will be placed in the channel and LWD and river boulders will be used to stabilize the regraded reach. Native wetland and riparian vegetation will be planted to provide shade and reduce bank erosion.

A temporary diversion of Miller Creek and dewatering of an approximately 120-ft section will be required to remove the instream weirs and install new grade controls in the channel (Appendix B, Sheet TE2). Diversion and dewatering are necessary to prevent sedimentation impacts to downstream portions of the stream during removal of the weirs. Diversion of the stream and

construction steps to remove weirs will be implemented only during low-flow conditions and will be consistent with conditions of the HPA permit for the project.

Measures to protect fish (e.g., trapping and relocating fish) in the section of the stream to be dewatered will be implemented prior to diverting flows and will be conducted by a qualified fish biologist consistent with conditions of the HPA permit. To divert the stream, the section of stream to be dewatered will be temporarily blocked with silt curtains, fish trapped and relocated, and the water diverted via a temporary dam, pumps, and pipes. The project area will then be dewatered, weirs and riprap removed and new grade controls installed, banks stabilized, and the stream diverted back into the project area. If necessary, the initial portions of the re-introduced flow would be captured downstream of the project area and pumped into upland areas for biofiltration prior to discharging back into Miller Creek. Diversion of the stream will be conducted only during the work hours when the weirs are being removed (i.e., one or two work days). At the end of each work day, work will be complete enough to allow water to be diverted back into the existing channel.

### **Instream Enhancement Project 3**

Major factors degrading the stream along this reach are erosion and downcutting upstream of a riprapped meander located approximately 300 ft downstream of the South 160<sup>th</sup> Street culvert. The primary goals of the enhancement are to remove constrictions that channelize flow (i.e., instream tire retaining walls) and stabilize the profile of Miller Creek. Other goals at this site include adding erosion control features along the banks, replanting native riparian and wetland species, removing riprap along both banks, removing a fence along the left bank, and enhancing instream habitat (see Figure 5.2-10; Appendix B, Sheet C5).

All instream tires will be removed throughout this reach, including tires along the left bank immediately downstream of the South 160<sup>th</sup> Street culvert and those that currently provide erosion control on the right bank upstream of the meander. Erosion control measures and replanting of native vegetation will be used to stabilize the banks where they have been disturbed during construction activities. Upstream of the riprapped meander, the banks will be regraded to create a high-flow channel and two gravel bars (see Figure 5.2-10; Appendix B, Sheet C5). LWD and river boulders will be used to stabilize the channel and reduce velocities. LWD and boulders will also enhance instream habitat. The removal of riprap will allow the stream to naturally meander. The high-flow benches will be planted with native vegetation. Non-native and invasive species will be replaced at the site with native riparian species.

### **Instream Enhancement Project 4**

Gravel bar enhancement features are included in Project 4 (see Figure 5.2-11; Appendix B, Sheet C6). The primary goal of this project is to reduce channel constrictions, which are causing bank erosion and scour, and enhance existing instream and riparian habitat. Two rock walls along the left and right streambanks, as well as an existing driveway, will be removed. Removal of the rock walls and driveway will restore natural channel geomorphology in this reach. Erosion control measures (e.g., sediment fencing and straw bales, erosion control fabric, or other appropriate BMPs) will be used along the banks if needed. LWD will be placed in the channel and on the gravel bars to maintain the existing channel grade, reduce erosion, and enhance instream habitat.

Removal of the two concrete rubble walls in the downstream reaches will enhance stream morphology and create more diverse instream habitat with pools and bars. It will also require erosion control along the banks; placement of woody debris will be used to stabilize gravel bars and promote deposition of suspended sediment.

Native riparian vegetation and wetland vegetation will be planted along the right bank within the project area and along the left bank where the site is accessible. The planted vegetation will provide shade and bank stability, as well as structural and species diversity to the riparian understory and forest. Invasive and non-native species will be removed from the site.

### **General Instream Habitat Enhancement**

In addition to placing LWD within each of the four instream enhancement projects, LWD will be placed at various locations throughout the 6,500-ft stretch of Miller Creek. LWD placement will generally conform to existing WDFW guidelines and be consistent with conditions of the HPA permit. The species (western redcedar, Douglas fir, and western hemlock [*Tsuga heterophylla*]) and size will be determined during the final design. The number and location of woody debris at each project site are shown on the detailed plan sheets in Appendix B (Sheets C3 through C6), and LWD will be field-placed by the project engineer or habitat biologist during construction. LWD will be designed to be stable in the stream. Natural anchoring methods, such as partially burying or locating the woody debris outside the low-flow channel, will be preferred over conventional anchoring methods (Appendix B, Sheet C10). The general locations of LWD will vary from site to site, depending on the design objective. Much of the woody debris can be salvaged from existing forested areas on the Master Plan Update project sites that will be filled by embankment construction. This salvage woody debris will have root wads attached. Table 5.2-8 summarizes final performance standards, evaluation approach, and contingency measures for all the instream habitat enhancements in Miller Creek.

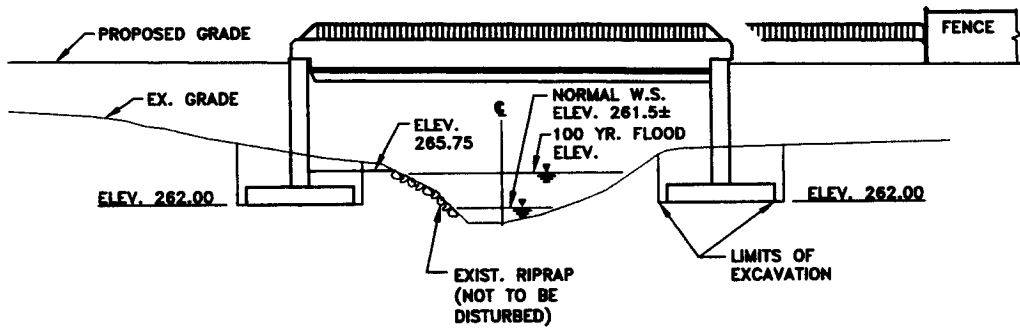
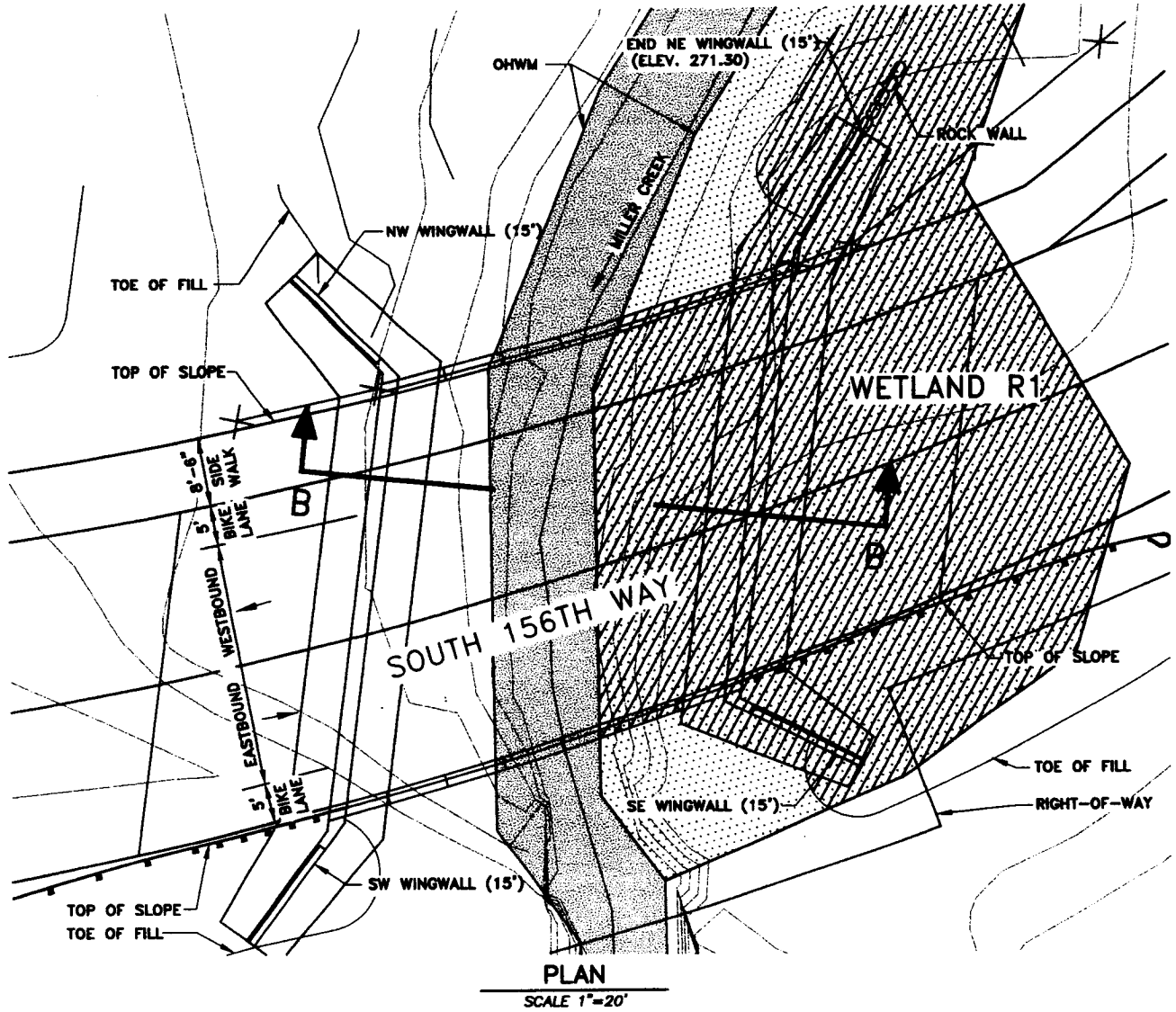
### **South 154<sup>th</sup> Street/South 156<sup>th</sup> Way Bridge Relocation**

To accommodate the RSAs for the third runway, it will be necessary to relocate South 154<sup>th</sup> Street north and west of its current alignment. The existing and proposed alignment of South 154<sup>th</sup> Street connects with South 156<sup>th</sup> Way. As a result of relocating this roadway, it will be necessary to replace and relocate the existing bridge over Miller Creek at South 156<sup>th</sup> Way. The existing timber bridge will be removed and replaced with a new bridge that will span the 100-year floodplain of the stream (see Figure 5.2-1; Appendix B, Sheets L1, L1.1, P1, and P2).

Elements of this bridge relocation will require restoring the streambanks after the existing timber bridge is removed. The existing stream channel under the bridge is armored with riprap and confined by the timber walls of the bridge. As a result of construction for the timber bridge, this segment of the stream was widened, and the channel bed is wider than the segments to the north and south. After removing the bridge, restoration activities will focus on re-establishing the streambanks. To accomplish this, a portion of the channel will be filled to restore the natural channel width (Figure 5.2-13; Appendix B, Sheet P1). Loose riprap will remain along the edge of the stream channel under the bridge segments only to provide stabilization under the bridge (see Figure 5.2-13; Appendix B, Sheets P1 and P2). Streambanks will be planted with native riparian vegetation.

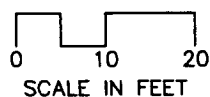
**Table 5.2-8. Final performance standards, evaluation approach, and contingency measures for instream habitat enhancements in Miller Creek.**

| Design Criteria                                                         | Performance Standard                                                                                                                                                                                                                                                                                         | Evaluation Approach                                                                                            | Contingency Measures                                                                                                                                                                                                                      |
|-------------------------------------------------------------------------|--------------------------------------------------------------------------------------------------------------------------------------------------------------------------------------------------------------------------------------------------------------------------------------------------------------|----------------------------------------------------------------------------------------------------------------|-------------------------------------------------------------------------------------------------------------------------------------------------------------------------------------------------------------------------------------------|
| 1. Add LWD to the creek channel.                                        | During all monitoring years, number of LWD features in stream remains stable or increases compared to baseline (record) conditions (LWD is woody material greater than 10 cm in diameter and 2 m in length).                                                                                                 | Record survey and visual inspection of channel                                                                 | Add LWD to create additional channel complexity.                                                                                                                                                                                          |
| 2. Stabilize areas of erosion by using native vegetation and LWD.       | During all monitoring years, number and density of habitat features (e.g., pools, riffles, bars, and undercut banks) remain stable or increase compared to baseline (record) conditions.<br>Cover of streambank vegetation in enhancement will meet performance standards for cover provided in Table 4.2-1. | Record survey and visual inspections.<br>Measure density and number of habitat features                        | Add LWD to create additional channel complexity and promote formation of pools and riffles.                                                                                                                                               |
| 3. Add gravel to degraded reaches where natural recruitment is limited. | Bank stabilizing LWD, as shown on record drawings, remains in place.<br>During all monitoring years, substrate is predominantly gravel (>50 percent) on bars and benches, as defined in as-built conditions.                                                                                                 | Site inspections and record drawings.<br>Assess substrate composition with pebble counts.<br>Visual inspection | Repair damaged bank if necessary.<br>Stabilize banks with additional LWD, live stakes, or seeding.<br>Evaluate source of sediment and remove/control.<br>Add channel features (e.g., large wood and boulders) to reduce bedload movement. |



NOTE:  
ALL DISTURBED AREAS WILL BE  
STABILIZED USING APPROPRIATE BMPS.

FILE: 281203\_15  
DATE: 10/19/01



**LEGEND**

- WETLAND R1
- WETLAND IMPACTS

**Figure 5.2-13**  
**South 156th Way**  
**Bridge Relocation**

AR 049227

### 5.2.2.8 Monitoring and Performance Standards

The monitoring approach, methods, schedules, and reporting for the instream habitat projects will be consistent with the approach outlined for all Master Plan Update mitigation projects (Section 4). Specific performance standards developed for the instream projects will be evaluated to ensure that the projects are meeting overall objectives and goals (Table 5.2-9).

**Table 5.2-9. Monitoring schedule for the instream enhancement projects.**

| Feature             | Activity                                                 | Frequency                                                                                | Data Collection Year |   |   |   |   |   |    |    |    |
|---------------------|----------------------------------------------------------|------------------------------------------------------------------------------------------|----------------------|---|---|---|---|---|----|----|----|
|                     |                                                          |                                                                                          | 0                    | 1 | 2 | 3 | 5 | 7 | 10 | 12 | 15 |
| Habitat Structures  | Inspection, stability of habitat features                | Annually (May) or after flows in excess of the 2-year peak flow during the first 3 years | X                    | X | X | X | X | X | X  | X  | X  |
| Substrate           | Pebble counts                                            | Semiannually (February/August)                                                           | X                    | X | X | X | X | X | X  | X  | X  |
| Erosion or Scouring | Visual evidence of erosion or scouring                   | Annually (May) or after flows in excess of the 2-year peak flow during the first 3 years | X                    | X | X | X | X | X | X  | X  | X  |
| Structures          | Evidence of cavitation or scouring                       | Annually (May) or after flows in excess of the 2-year peak flow during the first 3 years | X                    | X | X | X | X | X | X  | X  | X  |
| Adverse Flooding    | Inspect channel banks and riparian zone for ponded water | Twice yearly (February/November)                                                         | X                    | X | X | X | X | X | X  | X  | X  |
| Reports             |                                                          |                                                                                          | X                    | X | X | X | X | X | X  | X  | X  |

### Instream Habitat Conditions

Instream habitat will be monitored and evaluated against performance standards to ensure that these features provide the desired habitat and bank stabilization functions, and that instream LWD is stable, creating pools and meanders as designed. Table 5.2-8 lists specific performance standards, methods/parameters, and contingency measures for ensuring that the instream enhancements are meeting project goals and objectives. Monitoring instream habitat enhancement projects will focus primarily on evaluating parameters related to aquatic habitat quality such as habitat complexity (e.g., pool/riffle morphology, undercut banks), habitat features (e.g., LWD, gravel bars), and overall stream condition (e.g., lack of sedimentation or erosion, lack of man-made debris).

Monitoring methods and schedule for the instream enhancement projects are listed in Table 5.2-9. The schedule includes routine inspections and emergency inspections to be conducted following major flood events.



## **Biological Conditions**

The instream enhancement projects are designed to enhance biological as well as physical functions in Miller Creek and therefore, as part of the monitoring program for the Miller Creek instream projects, biological conditions will be evaluated and compared to existing or baseline conditions in the stream. Biological conditions will be assessed using BIBI (Kerans and Karr 1994; Fore et al. 1996; Kleindl 1995). Aquatic invertebrate populations will be sampled from representative riffles in Miller Creek, and the data will be analyzed to determine the BIBI score. The BIBI score integrates several physical and chemical conditions in the stream and watershed.<sup>26</sup>

Information gathered from this study will be used to evaluate changes in the invertebrate assemblages and relate them to other monitoring parameters and changes at the mitigation sites through the monitoring period. The BIBI scores obtained each year during the monitoring period will be compared to baseline values obtained from Miller Creek prior to mitigation, as well as to values obtained in other urban streams in the Puget Sound region. Since this methodology has not been widely applied to mitigation, BIBI data will be used to generally assess how the mitigation projects affect biotic integrity, but will not be linked to performance standards.

## **Vegetation**

Riparian and channel vegetation installed as part of the instream projects will be monitored and evaluated against the performance standards for the wetland and riparian buffer plantings described in Table 5.2-3. Monitoring methods and a schedule for evaluating riparian vegetation at the instream projects are listed in Table 5.2-4.

### **5.2.2.9 Maintenance and Contingency Plans**

Routine maintenance and contingency measures will be implemented consistent with the approach described in Section 4. A design goal for the instream enhancement features is that each enhanced reach function as a natural channel, requiring little or no maintenance. As indicated in Tables 5.2-8 and 5.2-9, periodic maintenance may be required to correct a variety of detrimental conditions to ensure that the projects meet performance standards.

In the event that contingency measures are necessary, the Port will use an adaptive management plan, as outlined in Section 4, to assess factors contributing to poor performance and design appropriate measures to change the contributing factors. Specific contingency measures for each of the performance standards for the instream projects are listed in Table 5.2-8.

All of the proposed enhancement projects have similar basic criteria for performance standards: (1) maintain minimum flow depths and velocities for fish passage, water quality, and sedimentation; (2) provide capacity for peak flows; and (3) reduce erosion of the bed and banks. The enhancement

---

<sup>26</sup> The BIBI is a numerical analysis of stream invertebrate data that assesses the degree to which macroinvertebrate populations have been altered by human disturbance. A strong correlation between levels of urbanization and BIBI scores exists (Fore et al. 1996; Horner et al. 1996). While BIBI measurements will monitor changes in the invertebrate assemblages in the stream, the values will also reflect activities in the watershed upstream of the mitigation, and thus cannot be used to unequivocally determine the effect of mitigation actions.

features were designed to meet these criteria; however, if flow rates and stream hydraulics differ substantially from the design flows used to develop the enhancement features, these features may not function as designed. If this occurs, reaches with enhancement features can be modified by:

- Modifying channel widths to reduce velocities and improve capacity
- Adding additional bank stabilization and erosion control methods
- Adding or modifying channel profile structures (e.g., log weirs) to reduce velocities

#### **5.2.2.10 Implementation of Buffer and Instream Enhancement Projects**

Implementation of the buffer and instream projects along Miller Creek will be coordinated with each other, and will be constructed in a manner consistent with federal, state, and local permits (e.g., CWA 404, HPA). In addition, construction of the mitigation projects will be coordinated with construction of the third runway embankment, security roads, utility relocations, South 156th Way bridge relocation, and stormwater management facilities to ensure that implementation of the mitigation projects is not impacted by other construction activities. A proposed implementation time line is presented in Table 5.2-10. Details regarding implementation steps, construction methods, and sequencing are included in this section.

#### **General Construction Sequencing**

Landscaping for the buffer enhancement will be coordinated with the instream enhancement projects. Wetland and riparian enhancements will start with installing TESC measures, demolishing of existing structures (e.g., buildings, driveways, fences), clearing and grubbing the site to remove non-native vegetation, and preparing the site for planting.

Temporary irrigation may be installed for some enhancement areas if necessary. Wetland and riparian vegetation will be planted in the fall immediately following site preparation (see Irrigation Plan sheets in Appendix B). BMPs for sediment and erosion control during these activities will minimize impacts to the stream and adjacent wetlands (Appendix B, Sheets TE1 through TE6). Measures include placing silt fence around work areas and staging areas, and placing straw bales or other BMPs at key locations within the project limits. Clearing and brush removal will be limited to only those work areas that the contractor is scheduled to begin within the following 2 weeks. The disturbed areas will be stabilized immediately after work in that area is completed. TESC measures will remain in place and be maintained until the entire site has stabilized.

Instream work will be scheduled during dry weather, when base flows are at a minimum, and will be restricted to allowable work times consistent with the HPA (i.e., July 15 to September 15). Prior to the start of any other construction activities, the TESC plan for the instream projects will be implemented and the TESC elements will be in place (Appendix B, Sheets TE1 through TE6). Once the temporary facilities are in place, the contractor will implement a plan for controlling water in areas requiring instream work. This may include excavating dewatering trenches, French drains, and sumps.

**Table 5.2-10. Proposed Implementation Timeline for Miller Creek In-Stream, Wetland, and Riparian Buffer Enhancements Projects**

| Project/Activity                                             | Year 1 <sup>a</sup> |   |   |   |   |   |   |   |   |   |   |   | Year 2 |   |   |   |   |   |   |   |   |   |   |   | Year 3 |   |   |   |   |   |   |   |   |   |   |   |
|--------------------------------------------------------------|---------------------|---|---|---|---|---|---|---|---|---|---|---|--------|---|---|---|---|---|---|---|---|---|---|---|--------|---|---|---|---|---|---|---|---|---|---|---|
|                                                              | J                   | F | M | A | M | J | J | A | S | O | N | D | J      | F | M | A | M | J | J | A | S | O | N | D | J      | F | M | A | M | J | J | A | S | O | N | D |
| <b>Miller Creek In-Stream Enhancements</b>                   |                     |   |   |   |   |   |   |   |   |   |   |   |        |   |   |   |   |   |   |   |   |   |   |   |        |   |   |   |   |   |   |   |   |   |   |   |
| Preconstruction meeting                                      | ■                   |   |   |   |   |   |   |   |   |   |   |   |        |   |   |   |   |   |   |   |   |   |   |   |        |   |   |   |   |   |   |   |   |   |   |   |
| TESC, site preparation                                       |                     | ■ | ■ |   |   |   |   |   |   |   |   |   |        |   |   |   |   |   |   |   |   |   |   |   |        |   |   |   |   |   |   |   |   |   |   |   |
| Install silt curtains and silt fencing                       |                     |   |   | ■ | ■ | ■ |   |   |   |   |   |   |        |   |   |   |   |   |   |   |   |   |   |   |        |   |   |   |   |   |   |   |   |   |   |   |
| Clear site and grade per plan                                |                     |   |   | ■ | ■ | ■ |   |   |   |   |   |   |        |   |   |   |   |   |   |   |   |   |   |   |        |   |   |   |   |   |   |   |   |   |   |   |
| Remove bridges, channel riprap, or other structures per plan |                     |   |   | ■ | ■ | ■ |   |   |   |   |   |   |        |   |   |   |   |   |   |   |   |   |   |   |        |   |   |   |   |   |   |   |   |   |   |   |
| Install LWD, stream gravel, bioengineering                   |                     |   |   |   |   |   | ■ |   |   |   |   |   |        |   |   |   |   |   |   |   |   |   |   |   |        |   |   |   |   |   |   |   |   |   |   |   |
| Hydroseed/implement planting plan                            |                     |   |   |   |   |   | ■ | ■ | ■ |   |   |   |        |   |   |   |   |   |   |   |   |   |   |   |        |   |   |   |   |   |   |   |   |   |   |   |
| Remove silt curtain and TESC measures                        |                     |   |   |   |   |   | ■ | ■ | ■ |   |   |   |        |   |   |   |   |   |   |   |   |   |   |   |        |   |   |   |   |   |   |   |   |   |   |   |
| Produce record drawings, conduct baseline monitoring         |                     |   |   |   |   |   | ■ | ■ | ■ |   |   |   |        |   |   |   |   |   |   |   |   |   |   |   |        |   |   |   |   |   |   |   |   |   |   |   |
| Begin compliance monitoring                                  |                     |   |   |   |   |   |   |   |   |   |   |   |        |   |   |   |   |   |   |   |   |   |   |   |        |   |   |   |   |   |   |   |   |   |   |   |
| <b>Wetland and Riparian Buffer Enhancements</b>              |                     |   |   |   |   |   |   |   |   |   |   |   |        |   |   |   |   |   |   |   |   |   |   |   |        |   |   |   |   |   |   |   |   |   |   |   |
| Preconstruction meeting                                      |                     |   |   |   |   |   | ■ |   |   |   |   |   |        |   |   |   |   |   |   |   |   |   |   |   |        |   |   |   |   |   |   |   |   |   |   |   |
| TESC, site preparation                                       |                     |   |   |   |   |   | ■ | ■ | ■ |   |   |   |        |   |   |   |   |   |   |   |   |   |   |   |        |   |   |   |   |   |   |   |   |   |   |   |
| Remove debris and structures per plan                        |                     |   |   |   |   |   | ■ | ■ | ■ |   |   |   |        |   |   |   |   |   |   |   |   |   |   |   |        |   |   |   |   |   |   |   |   |   |   |   |
| Remove non-native plants per plan                            |                     |   |   |   |   |   | ■ | ■ | ■ |   |   |   |        |   |   |   |   |   |   |   |   |   |   |   |        |   |   |   |   |   |   |   |   |   |   |   |
| Install plants per planting plan <sup>b</sup>                |                     |   |   |   |   |   | ■ | ■ | ■ |   |   |   |        |   |   |   |   |   |   |   |   |   |   |   |        |   |   |   |   |   |   |   |   |   |   |   |
| Produce record drawings                                      |                     |   |   |   |   |   | ■ | ■ | ■ |   |   |   |        |   |   |   |   |   |   |   |   |   |   |   |        |   |   |   |   |   |   |   |   |   |   |   |
| Conduct baseline monitoring                                  |                     |   |   |   |   |   | ■ | ■ | ■ |   |   |   |        |   |   |   |   |   |   |   |   |   |   |   |        |   |   |   |   |   |   |   |   |   |   |   |
| Begin maintenance and compliance monitoring                  |                     |   |   |   |   |   | ■ | ■ | ■ |   |   |   |        |   |   |   |   |   |   |   |   |   |   |   |        |   |   |   |   |   |   |   |   |   |   |   |

<sup>a</sup> Year one starts with the first construction season following issuance of permits. Implementation of mitigation projects may vary from this proposed schedule depending upon coordination with other Master Plan Update projects, contract obligations, or final approval.

<sup>b</sup> Plant procurement will begin 6 to 12 months prior to the anticipated planting date to ensure that plants in the specified quantities and species are available by the scheduled planting date. Planting will be phased such that coniferous species will be planted following the third year of monitoring.

Temporary berms (using sandbags or other structures that would not be driven into the channel) may be used to divert flows around bank work. Silt curtains will be installed prior to any LWD placement except for channel spanning LWD (Appendix B, Sheet TE5). Silt curtains will extend completely around the project site. Any turbid water inside the silt curtain will be pumped out and directed through settling ponds and straw bale filters prior to being discharged back into the stream. All instream work will be performed in a manner to protect fish and other aquatic organisms, consistent with the HPA permit conditions.

Excavation and partial burial (Appendix B, Sheet C10) will anchor LWD. LWD will be excavated and placed by hand tools or from the streambanks using equipment with extendable arms (e.g., backhoe). No equipment will be allowed to drive into or cross the stream channel. Access to project sites will avoid wetlands where possible. If access through non-wetland areas is not feasible, protective plywood mats will be placed over access paths and work areas to protect wetlands and the stream. Silt fences will be installed along all access routes. Vegetation clearing will be limited, and vegetation will be mowed rather than removed wherever possible to gain access to project sites. Access routes will be stabilized and revegetated immediately following construction.

Plant material used in the mitigation will be obtained from commercial nurseries. Nurseries will be required to certify that the plant material is legally procured and from the appropriate geographic source. Plant material used in the mitigation will be grown in the area bounded on the north by the Fraser River Valley, British Columbia; on the east by the 1,000-ft elevation of the Cascades; on the west by the 1,000-ft elevation in the Olympic or Coast ranges; and on the south by the Willamette Valley.

### **Construction Steps**

Construction steps required to implement the instream and buffer enhancement projects are described below. General construction steps, as well as construction steps for each of the four instream projects and placement of LWD in the stream within the project area, are included.

### **General Conditions**

- On award of the contract, the contractor will provide the Port with any required pre-construction submittals, work plans, and schedules.
- A pre-construction meeting will be held with the contractor, architect/engineer, and wetland scientist to review submittals, work plans, schedules, and permit conditions.
- The contractor will be responsible for ensuring that the work is performed in compliance with all permit conditions and shall maintain a copy of permits on-site.
- Work will be coordinated to avoid re-entry and damage to areas that have previously been planted; work will be conducted so that no other work will impact completed landscaping.
- Areas where landscaping has been completed will be off-limits to all vehicular traffic, and pedestrian traffic will be strictly limited.

- Construction will take place during the dry season; any instream work or work below the OHWM will take place only during the allowable work times, consistent with HPA permit conditions (i.e., July 15 to September 15).
- Plant procurement shall be coordinated with the grading and irrigation installation schedules. Plants will be secured 6 to 12 months prior to the scheduled planting season to ensure that plants are available in the quantities and species required by the planting plan.

#### **Site Preparation**

- Establish vertical and horizontal site controls and maintain through construction to record drawings.
- Identify and flag limits of work for mitigation site.
- Identify staging areas and temporary access/haul roads.
- Implement TESC plan and install TESC measures.
- Install fencing (orange barrier) around areas to be protected (e.g., stream channel, existing wetlands, vegetation/trees to be retained).
- Maintain security of the site through construction.
- Establish temporary access/haul roads.
- Establish staging and stockpile areas.
- Implement a spill control plan and identify fueling areas.

#### **Clearing, Excavation, and Grading**

- Clear and grub portions of the site as specified; clear structures and impervious surfaces and existing non-native vegetation in selected areas.
- In selected areas, grade per specifications.
- Install irrigation as specified in selected areas.

#### **Instream Project 1 (Appendix B, Sheets C3, C9, C10, and TE1)**

- Install silt curtains and silt fencing per specifications. This can be done in phases as approved by the engineer.
- Remove riprap, footbridges, railroad ties, and fences identified on plan sheet.
- Regrade portions of the area as needed to meet grading from Vacca Farm projects.
- Install LWD in the main channel and side channel.
- Implement planting plan for the main channel and side channel.
- Seed disturbed areas (including any access roads and staging areas).
- Maintain TESC measures adjacent to restored stream bank until adjacent riparian buffer has been planted and stabilized.

- Remove silt curtain and TESC measures once the site is stabilized and approved by the engineer and wetland scientist.

**Instream Project 2 (Appendix B, Sheets C4, C8 through C10, TE2)**

- Install silt curtains and silt fencing per specifications.
- Clear and grade the minimum area required for construction of the project.
- Remove two footbridges identified on plan sheet.
- Remove riprap associated with two weirs; remove the two weirs.
- Install coir logs and coir lifts to stabilize areas where riprap is removed.
- Install LWD, boulders, and stream gravel.
- Seed disturbed areas.
- Implement planting plan for stream banks, wetland, and riparian areas adjacent to project site.
- Remove silt curtain and TESC measures once the site is stabilized and approved by the engineer and wetland scientist.

**Instream Project 3 (Appendix B, Sheets C5, C8 through C10, TE3)**

- Install silt curtains and silt fencing per specifications.
- Clear and grade the minimum area required for construction of the project.
- Remove instream tires lining left and right banks; remove riprap.
- Construct high-flow benches and gravel bars.
- Install LWD, boulders, and stream gravel.
- Install coir lifts, coir logs, and plant banks with live stakes to stabilize new banks.
- Seed disturbed areas.
- Implement planting plan for channel banks, wetland, and riparian areas adjacent to the project site.
- Remove silt curtain and TESC measures once the site is stabilized and approved by the engineer and wetland scientist.

**Instream Project 4 (Appendix B, Sheets C6, C8 through C10, TE4)**

- Install silt curtains and silt fencing per specifications.
- Clear and grade the minimum area required for construction of the project.
- Remove riprap rock walls and existing driveway.
- Construct three high-flow benches and gravel bars; construct new channel banks.
- Install LWD, river boulders, and stream gravel.
- Place geotextile over new banks.

- Seed disturbed areas.
- Implement planting plan for new channel banks, wetland, and riparian areas adjacent to the project site.
- Remove silt curtain and TESC measures on the east bank once the site is stabilized and approved by the engineer and wetland scientist.

#### **Closeout**

- Complete site cleanup by removing temporary haul/access roads and staging areas.
- Remove construction equipment and debris.
- Hydroseed and/or install plants in any temporary staging areas or access roads within the mitigation site boundaries.
- Hydroseed erosion control mix in temporary staging areas/access roads outside the mitigation boundaries.
- Install permanent fence and/or signs along buffer boundary.

#### **Record Drawings, Monitoring, and Maintenance**

- Produce grading record drawings for instream enhancement projects and planting plan record drawings for wetland and buffer enhancement areas.
- Complete a baseline report, including record drawings, buffer boundaries along Miller Creek, and final monitoring plan (e.g., locations of monitoring plots, baseline conditions).
- Begin compliance monitoring during the first growing season after planting is complete. Submit annual monitoring reports for the 15-year monitoring period.
- Conduct maintenance (e.g., weed management, WHMP) and implement any necessary contingency measures to meet performance standards.

#### **5.2.3 Drainage Channel Replacement Plan**

Three small intermittent drainage channels (Drainage Channels A, B, and W) are located in the acquisition area on the west side of the existing runway (see Section 2, Figure 2.1-2).<sup>27</sup> These drainage channels currently convey water (groundwater and surface water) from the hillside on the western edge of the airport to Miller Creek and the wetlands adjacent to Miller Creek. Channel A is located immediately east of 12<sup>th</sup> Avenue South in a roadside drainage ditch. Channel B originates in Wetland 37f and is located west of 12<sup>th</sup> Avenue South. Channel B provides a surface water connection between Wetland 37f and Wetland R9. Channel W is located east of the existing perimeter road within the current Airport Operation Area (AOA). This channel originates in Wetland 20b and flows northwest through a culvert and under the perimeter road; it ultimately empties into Channel A.

Approximately 1,290 linear ft of the existing drainage channels will be filled as a result of third runway construction (Section 3). The Port proposes to mitigate for filling these channels by

---

<sup>27</sup> Ditches on the Vacca Farm (see Section 3.4) are not included in this mitigation because their functions are enhanced as part of the Vacca Farm restoration projects (see Section 5.1).

replacing and restoring their functions on-site. A subsurface drainage system in the fill embankment will collect water infiltrating the embankment and direct this water to surface water channels at the base of the embankment. Water from the replacement drainage channels will be directed to riparian wetlands along Miller Creek (Figure 5.2-14). The surface water channels will be designed to replace the 100-year flow conveyance capacity of the channel lengths being filled. Replacement drainage channels will be permanent features and their construction will be coordinated with the Miller Creek buffer enhancement projects, embankment construction activities, and stormwater facility construction.

### 5.2.3.1 Goals, Objectives, and Design Criteria

To replace the functions of existing channels, four replacement drainage channel areas will be designed along the west side of the perimeter roadway at the base of the fill embankment. The goals of this mitigation action are listed below and described in Table 5.2-11.






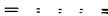

- The replacement drainage channels will provide adequate (100-year) flow conveyance functions.
- The replacement drainage channels will collect seepage from the embankment to maintain base flows in Miller Creek and hydrology of downslope wetlands.
- The replacement drainage channels will provide open channel lengths equivalent to the existing drainage channel lengths.
- The replacement drainage channels will be planted with a vegetated buffer to provide shade to enhance water quality in Miller Creek and other wetlands.

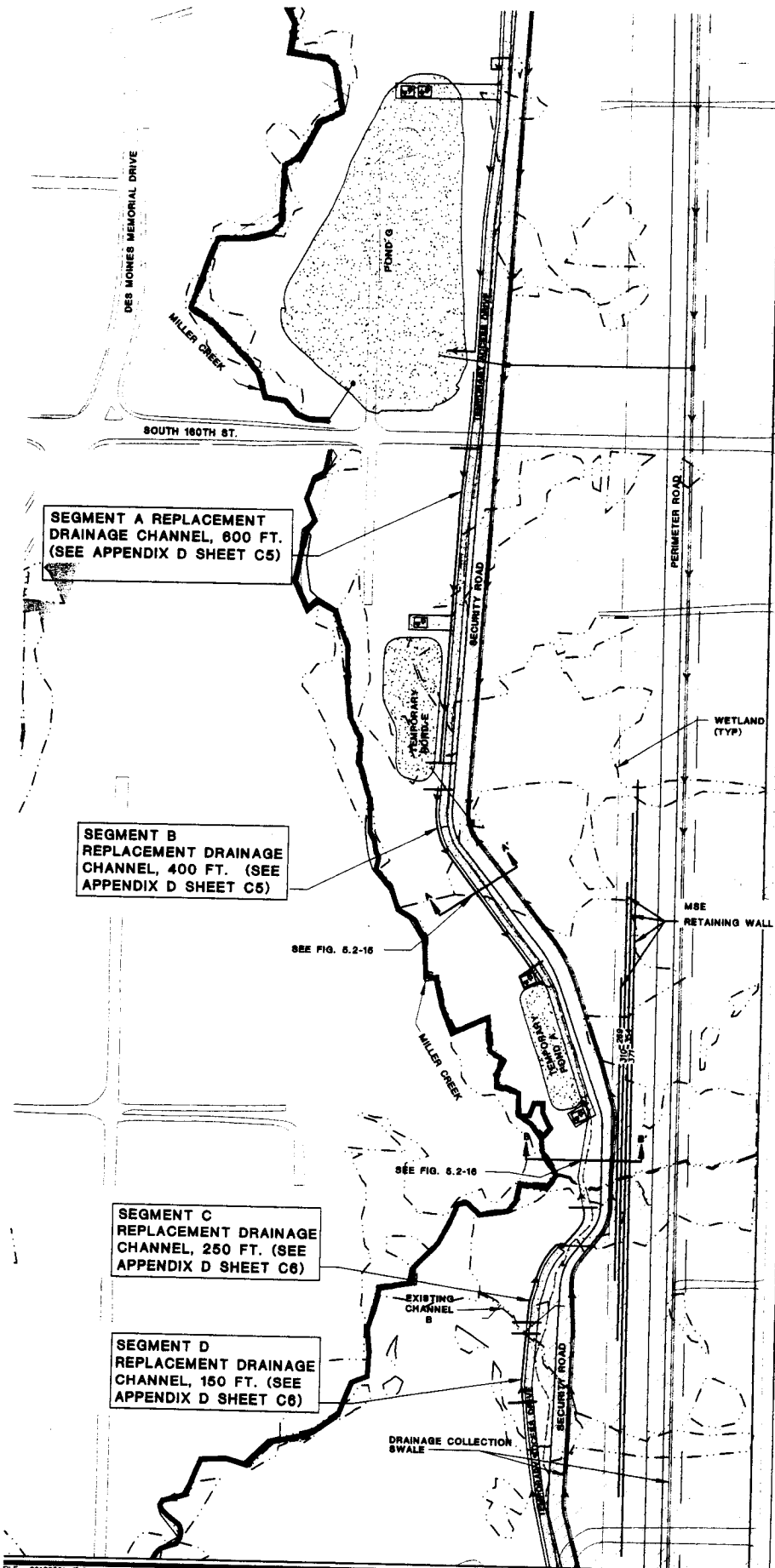
**Table 5.2-11. Mitigation goals, design objectives, and design criteria for replacement drainage channels.**

| Design Objectives                                                                                                      | Design Criteria                                                                                                                                                                                                                                                                                   |
|------------------------------------------------------------------------------------------------------------------------|---------------------------------------------------------------------------------------------------------------------------------------------------------------------------------------------------------------------------------------------------------------------------------------------------|
| <b>Goal 1: The replacement drainage channels will provide adequate (100-year) flow conveyance functions</b>            |                                                                                                                                                                                                                                                                                                   |
| Provide channel flow capacity for expected runoff.                                                                     | Construct the replacement channel to convey the 100-year, 24-hour design storm and seepage flows emanating from the embankment.<br><br>Channel depths will be a minimum of 2 ft deep with side slopes of 3:1 or flatter; or if slopes are steeper, log and rock weirs will protect channel banks. |
| <b>Goal 2: The replacement channels will collect seepage to maintain base flows and wetland hydrology</b>              |                                                                                                                                                                                                                                                                                                   |
| Integrate channel into embankment drainage layer so groundwater can be collected.                                      | Construct channels down gradient and hydrologically connected to the drainage layer of the embankment.                                                                                                                                                                                            |
| Convey water to riparian wetlands downslope from the embankment.                                                       | Direct water in drainage channels to discharge points in or adjacent to riparian wetlands along Miller Creek (Wetlands A13, 18, 37, 39, 44a, and A9).                                                                                                                                             |
| <b>Goal 3: The replacement channels will provide an open channel of equivalent length as the existing channel</b>      |                                                                                                                                                                                                                                                                                                   |
| Construct new channels with equivalent length, substrate, and streamside vegetation.                                   | Construct new channels with a minimum length of 1,290 ft.<br><br>Channel substrate will be stable and have slopes of less than 3:1. Where steeper channel slopes are required, protect from down cutting with log weirs.                                                                          |
| <b>Goal 4: Plant a vegetated buffer along the length of channel to provide shade, which will enhance water quality</b> |                                                                                                                                                                                                                                                                                                   |
| Provide a vegetated buffer along the length of the mitigation channel.                                                 | Plant native shrubs at greater than 2,100 individuals per acre along channel banks.<br><br>Plant native trees greater than 280 trees per acre along channel banks.                                                                                                                                |



LEGEND

-  Sedimentation Pond
-  Pumping Facility
-  Fill Embankment
-  Replacement Drainage Channel
-  Temporary Drainage Channel
-  Drainage Collection Swale
-  Wetland



AR 049237

FILE: 29120301\_R5.2-14  
 DATE: 12/14/00  
 SOURCE: HNTB

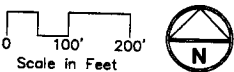


Figure 5.2-14  
 Location of Replacement Drainage Channel and Swales along the West Side of the Third Runway Embankment

### **5.2.3.2 Mitigation Site Description**

The replacement channels will be located in areas that are currently predominantly residential lawns, upland forest, or emergent wetlands. The replacement drainage channels will be constructed on the west side of the perimeter road that will run immediately west of the new embankment for the third runway (see Figure 5.2-14).

### **5.2.3.3 Ownership**

The Port owns the property where the replacement drainage channels will be relocated.

### **5.2.3.4 Rationale For Selection**

The drainage channel mitigation replaces the water conveyance functions of the channels that will be impacted by the project. Replacement drainage channels will be constructed as close to the original channel location as possible. The existing channels currently convey water from the hillslope to the west of STIA to downgradient wetlands and Miller Creek. The channels are designed to ensure that the discharge of water to wetlands adjacent to Miller Creek continues.

### **5.2.3.5 Constraints**

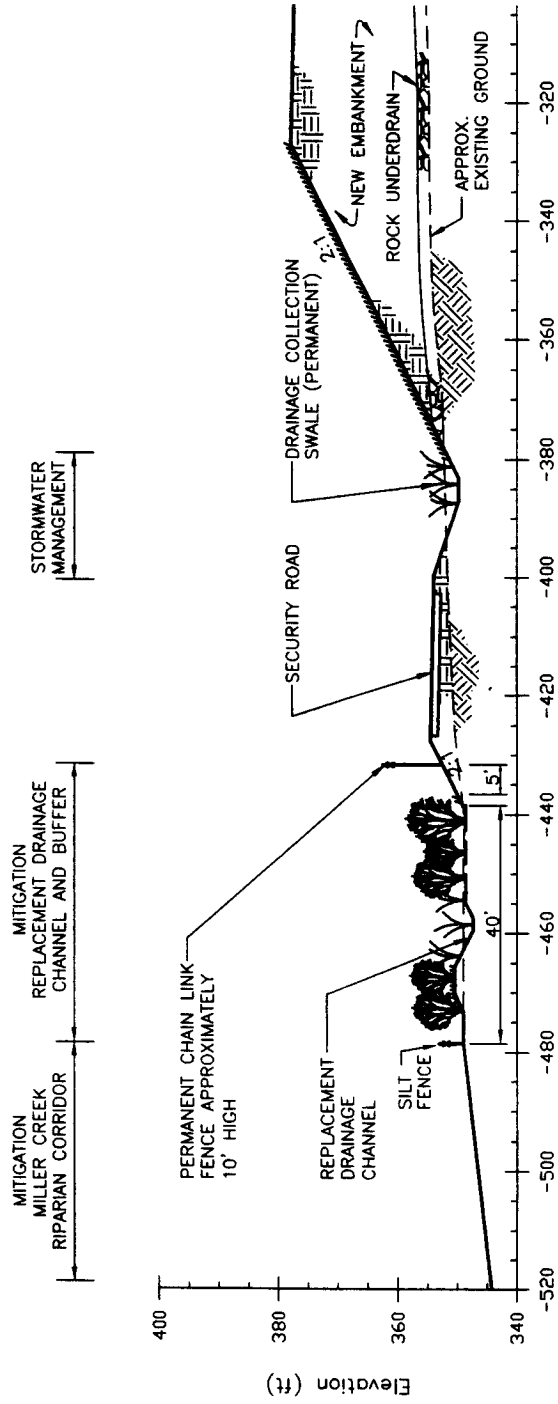
There are no constraints that affect implementation of the planned mitigation action.

### **5.2.3.6 Ecological Assessment of the Mitigation Site**

The replacement channels will be located in areas that are currently residential, upland forest, or emergent wetlands. A detailed description of ecological conditions at these sites is given in the *Wetland Delineation Report* (Parametrix 2000b).

### **5.2.3.7 Replacement Drainage Channel Mitigation Design**

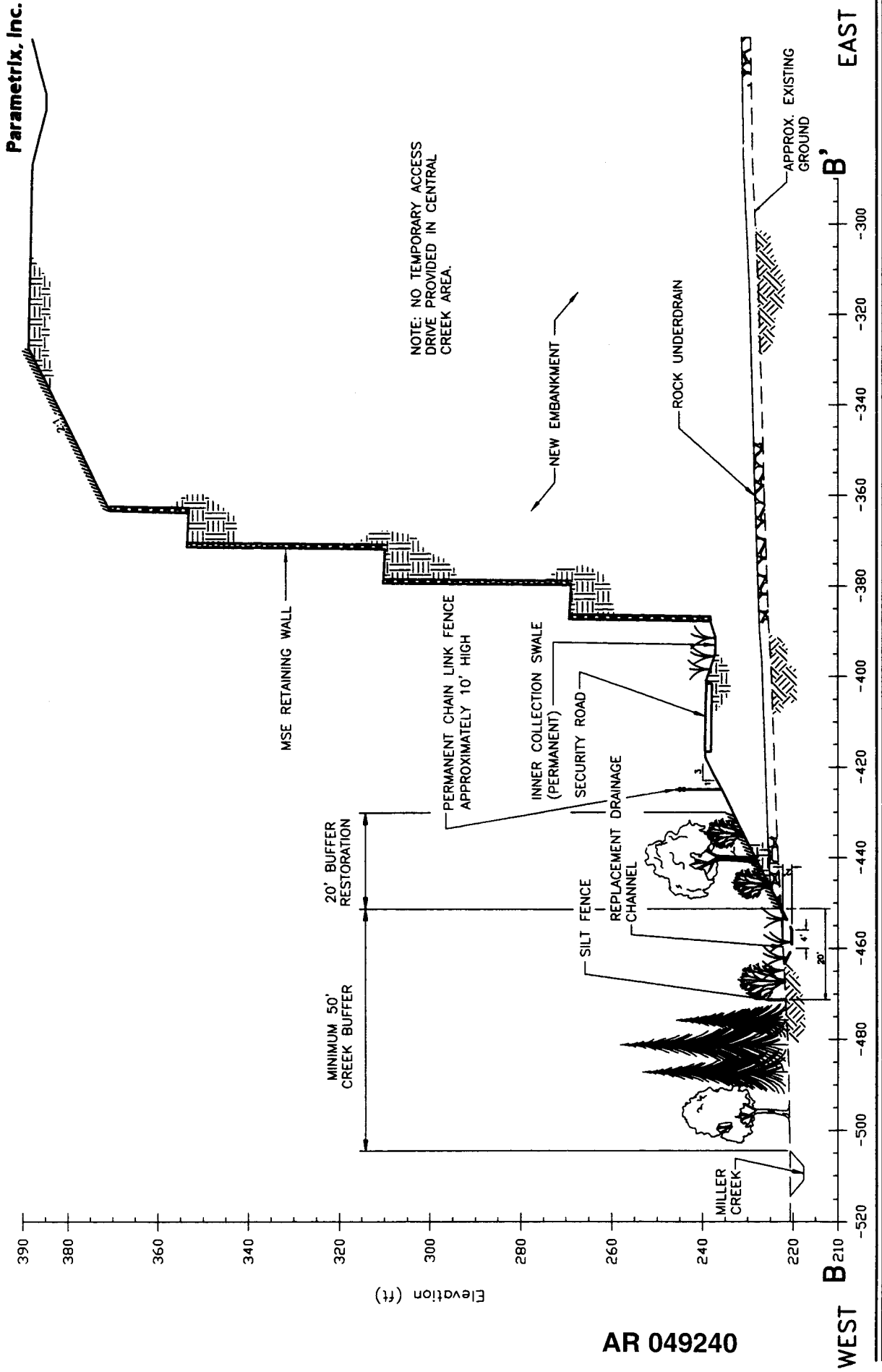
A permanent drainage collection swale will be constructed at the toe of the embankment to intercept surface water runoff from the embankment and security road. The replacement drainage channels located on the west side of the new security road will receive water from the underdrain system the embankment slope, and the non-pollution generating surfaces of the security road. The underdrain system collects water infiltrating into the embankment (see Figure 5.2-14 through 5.2-16; Appendix D, Sheets C5, C6, and C7 ). The replacement channels will then direct this water to downslope wetlands.



**Figure 5.2-15**  
**Typical Cross Section of the Replacement**  
**Drainage Channel, Drainage Collection**  
**Swale and Third Runway Embankment**

SCALE: HORIZONTAL 1"=30'  
 VERTICAL 1"=30'

FILE: 2912\_5  
 DATE: 10/23/01  
 SOURCE: HNTB



AR 049240

FILE: 29/203\_5.2-16  
DATE: 09/24/01  
SOURCE: FHNB

REFERENCE: NRMP 2000

SCALE: HORIZONTAL 1"=30'  
VERTICAL 1"=30'

**Figure 5.2-16**  
**Cross Section B-B' of the Replacement**  
**Drainage Channel, Drainage Collection**  
**Swale, and Third Runway Retaining Wall**

During construction of the embankment and retaining wall, west of the third runway, the collection swale will collect construction runoff from the outermost portion of the embankment and route the water to a sedimentation and water treatment facility. After construction of the embankment and retaining walls is complete, the collection swale will be retained to intercept surface water runoff from the embankment and direct it to the replacement drainage channels via culverts under the perimeter road. The replacement drainage channels (a minimum of 1,290 linear ft of the collection swale) will convey groundwater and seepage from the embankment and runoff water to adjacent wetlands (see Figure 5.2-14; Appendix D, Sheet C3, and Sheets C4 through C8).

### **Channel Size and Slope**

The drainage channels will be designed to convey the 100-year peak flow rate for runoff and groundwater collected by the swale. The maximum flow depth in the channel will be determined by anticipated flow conditions; the channel depth will range from 2 to 4 ft with up to 3:1 side slopes. The bottom width will be controlled by the flow minimum design depth (0.5 ft) and channel slope, but will be a minimum of 3 ft wide. Flow control weirs, used to prevent erosion, sedimentation, scouring, and downstream deposition impacts.

### **Discharge Points**

The drainage channels will discharge into downslope wetlands to maintain wetland hydrology, disperse runoff, and to provide base flows to Miller Creek (i.e., Wetlands A13, 18, 37, 39, 44a, and R9; Appendix D, Sheets C4 through C7). At the discharge points, the channels will be designed to prevent erosion or scouring impacts by utilizing the design standards for flow spreaders identified in the *Stormwater Management Manual for Western Washington* (Ecology 2001b) in the receiving channel or wetlands through the use of dispersal trenches or similar construction. The dispersal trenches will include installing weirs and/or soil stabilization (i.e. live stakes, branch packs) at discharge points to prevent erosion. Flow rates at each dispersal trench will generally range between 0.1cfs for two-year storms and less than 0.5 cfs for 100-year storms. Dispersal trenches and weirs are designed to spread and discharge these flows over a 50 – 100 foot zone.

### **Groundwater Seepage and Hydrology**

Existing channels convey seepage and stormwater to downstream wetlands and Miller Creek. The replacement drainage channels will collect seepage water that discharges from the embankment and distribute it to downslope wetlands using rock berms or infiltration swales. The hydrology of wetlands downslope of the new embankment will be monitored following construction to ensure that wetland hydrology is maintained.

#### **5.2.3.8 Implementation**

The replacement drainage channel will be constructed as part of the stormwater facilities for the third runway embankment. Channel construction and planting of the vegetated buffers will be coordinated with construction of the embankment and stormwater facilities, the Miller Creek riparian wetland and buffer enhancements, and temporary restoration of wetland impacts. Implementation of the replacement drainage channel is described in Section 5.2.4.12

## **Landscape Plan**

The landscape plan for the replacement channels has been designed to be consistent with the Port's WHMP. The side slopes and buffers along the channels will be planted with native vegetation to provide shade. The vegetation will also contribute organic matter to the drainage channels and ultimately to Miller Creek. The vegetated buffer will extend from the edge of the channel to approximately 10 ft west of the security road (see Figures 5.2-15 and 5.2-16; Appendix B, Sheets L2 through L5; Appendix D, Sheets C5 and C8). This distance is designed to provide a minimum of 5 ft of unvegetated area on either side of the perimeter fence as required for airport security. Native plant species that will not attract hazard wildlife (see Table 5.1-12) will be planted adjacent to the channel.

## **Monitoring and Performance Standards**

The drainage channels will be monitored consistent with the monitoring approach, methods, schedules, and reporting outlined in Section 4. Hazard wildlife will be monitored consistent with the Port's WHMP (USDA 2000). Monitoring and performance standards for the replacement drainage channels will evaluate not only the functioning of the drainage channels (flow conveyance, stability of substrate, evidence of erosion) and the vegetated buffers, but the hydrology of downslope wetlands as well. Specific performance standards, types of parameters to evaluate, and contingency measures for the replacement drainage channels are provided in Table 5.2-12. Replacement drainage channels will be monitored following the schedule and methods provided in Table 5.2-13.

## **Hydrology**

The replacement drainage channel design provides surface water to support the hydrology of downslope wetlands to ensure that existing wetland functions are maintained. The depth and duration of soil saturation will be monitored periodically during the 15-year monitoring period in wetlands between the embankment and Miller Creek (i.e., Wetlands 18 and 37). Groundwater monitoring will use standard groundwater monitoring wells installed in the wetlands between the embankment and Miller Creek. Groundwater levels will be monitored monthly for the first 5 years of the monitoring period, and then every other month for the remainder of the monitoring period. Specific performance standards and contingency measures for maintaining hydrology in downslope wetlands are included in Table 5.2-12.

## **Vegetation**

Vegetation in the drainage channel buffers will be monitored to evaluate plant survival, native plant cover, invasive species cover, plant density, and overall health and vigor consistent with the approach outlined in Section 4.

### **5.2.3.9 Site Protection**

The channels will be protected from adjacent airport development by fencing and signs that designate the area as permanently protected mitigation sites. The area will be covered by the restrictive covenants drafted to permanently protect the mitigation sites (Appendix G).

**Table 5.2-12. Final performance standards, evaluation approach, and contingency measures for replacement drainage channels.**

| Design Criteria                                                                                                                                                          | Performance Standard                                                                                                                                                                                                                                                                                                                                                                                                                                                                                                                                                                                                                                                                                                                                                                                                                                                                                                                                                                                                                                                                                                                                                    | Evaluation Approach                                                                                                                                                                                                                                                                                                                                                                                                                                                                                                                                                                                                                  | Contingency Measures                                                                                                                                                                                                                                                                                                                                                                                                                                                                                                                                                                                                                                                                                                                                                                                                                                                                                                                                                                                                 |
|--------------------------------------------------------------------------------------------------------------------------------------------------------------------------|-------------------------------------------------------------------------------------------------------------------------------------------------------------------------------------------------------------------------------------------------------------------------------------------------------------------------------------------------------------------------------------------------------------------------------------------------------------------------------------------------------------------------------------------------------------------------------------------------------------------------------------------------------------------------------------------------------------------------------------------------------------------------------------------------------------------------------------------------------------------------------------------------------------------------------------------------------------------------------------------------------------------------------------------------------------------------------------------------------------------------------------------------------------------------|--------------------------------------------------------------------------------------------------------------------------------------------------------------------------------------------------------------------------------------------------------------------------------------------------------------------------------------------------------------------------------------------------------------------------------------------------------------------------------------------------------------------------------------------------------------------------------------------------------------------------------------|----------------------------------------------------------------------------------------------------------------------------------------------------------------------------------------------------------------------------------------------------------------------------------------------------------------------------------------------------------------------------------------------------------------------------------------------------------------------------------------------------------------------------------------------------------------------------------------------------------------------------------------------------------------------------------------------------------------------------------------------------------------------------------------------------------------------------------------------------------------------------------------------------------------------------------------------------------------------------------------------------------------------|
| <p>1*. Construct the replacement channel to convey the 100-year, 24-hour design storm, and seepage water collected by the embankment drain layer and adjacent areas.</p> | <p>Channel depths will be a minimum of 2 ft deep with side slopes of 3:1 or gentler with log and rock weirs to protect channel banks.</p>                                                                                                                                                                                                                                                                                                                                                                                                                                                                                                                                                                                                                                                                                                                                                                                                                                                                                                                                                                                                                               | <p>Monitor stability by examining for scour, bank erosion, etc. once per year and following storm events greater than the ten year storm.</p>                                                                                                                                                                                                                                                                                                                                                                                                                                                                                        | <p>Enlarge channel if conveyance is inadequate.</p>                                                                                                                                                                                                                                                                                                                                                                                                                                                                                                                                                                                                                                                                                                                                                                                                                                                                                                                                                                  |
| <p>2. Direct water in drainage channels to discharge points in or adjacent to riparian wetlands along Miller Creek (Wetlands A13, 18, 37a, 39, 44a, R9).</p>             | <p>Flowing water will be present in Segment B and Segment C from December to June in years of normal<sup>b</sup> rainfall.</p> <p>Groundwater in wetlands with predominantly organic soils (Portions of Wetland 18, 37a, R14a, A14b, and 44a) will be within 10 inches of the soil surface at least between March and mid-June in years of normal<sup>b</sup> rainfall.</p> <p>Other wetlands with predominantly mineral soils will have soils saturated in the upper part to mid-April in years of normal<sup>b</sup> rainfall.</p> <p>Wetland indicator status (WIS) of the dominant non-invasive plant species will not differ from pre-project conditions during or at the end of the monitoring period. Each vegetation strata (trees, shrubs, and emergents) shall be assessed separately, and have separate conclusions. Statistically valid sampling procedures will be employed to monitor these potential changes, in all areas where there is a potential to change the post construction hydrology (downslope of the embankment and the borrow sites). WIS status of the vegetation will be calculated as in the 1987 USACE wetland delineation manual.</p> | <p>Measurements of channel baseflow by installing weirs that allow quantity of water flowing through channels to be determined.</p> <p>Map organic and inorganic soils; characterize wetland vegetation. Monitor duration and depth to water table in wetlands to determine if wetland hydrology persists.</p> <p>The data will be related to the wetland indicator status of dominant wetland plants, the information on vegetation tolerance of various hydrologic regimes, and the intensity of reducing soil conditions (i.e., iron reduction creating mottled and gleyed soil colors, or organic matter accumulation). This</p> | <p>Modify discharge points from channel to wetlands to meet performance standards.</p> <p>Divert treated stormwater from upslope stormwater ponds to drainage channels.</p> <p>Improve drainage paths to convey water to wetlands.</p> <p>Remove obstructions and/or enlarge channels as needed.</p> <p>Reconfigure drainage channels to maintain flows (i.e., longer drainage channels to collect more water for distribution to wetlands).</p> <p>If wetlands are found to be drier than under pre-project conditions:</p> <p>Divert treated stormwater from upslope stormwater ponds to drainage channels (the source of this stormwater could be from biofiltration swales, filter strips, etc. treating runoff from the perimeter road).</p> <p>Reconfigure discharge (i.e., location, size, and number of discharge points that distribute water to wetlands from drainage channels).</p> <p>If these wetlands are wetter than under pre-project conditions:</p> <p>A portion of the water in the drainage</p> |

**Table 5.2-12. Final performance standards, evaluation approach, and contingency measures for replacement drainage channels (continued).**

| Design Criteria                                                                                                                                   | Performance Standard                                                                                                                                                                                                                                                                                                                                                                                                                                                                                                                                                                                                                            | Evaluation Approach                                                                                                                                                                                                                                                                                                                                         | Contingency Measures                                                                                                                                                                                                                                                                                                                                                                                                            |
|---------------------------------------------------------------------------------------------------------------------------------------------------|-------------------------------------------------------------------------------------------------------------------------------------------------------------------------------------------------------------------------------------------------------------------------------------------------------------------------------------------------------------------------------------------------------------------------------------------------------------------------------------------------------------------------------------------------------------------------------------------------------------------------------------------------|-------------------------------------------------------------------------------------------------------------------------------------------------------------------------------------------------------------------------------------------------------------------------------------------------------------------------------------------------------------|---------------------------------------------------------------------------------------------------------------------------------------------------------------------------------------------------------------------------------------------------------------------------------------------------------------------------------------------------------------------------------------------------------------------------------|
| <p>3. Plant native shrubs at greater than 2,100 individuals per acre and native trees at greater than 280 trees per acre along channel banks.</p> | <p>Shrub density will be at least 2,100 individuals per acre. Tree density will be at least 280 stems per acre.</p> <p>At Year 1, survival of planted stock will be 100%. Average tree and shrub survival will be at least 80% during the first 3 monitoring years.</p> <p>Average canopy cover of native species will be at least 80% by monitoring year 15.<sup>d</sup></p> <p>By the end of year 3, plant diversity in each stratum will not decrease by more than 10% from the number and type of plants installed at baseline.</p> <p>Cover of non-native invasive<sup>e</sup> species will be no more than 10% by monitoring year 15.</p> | <p>analysis will be used to determine whether the post-construction hydrology observed through monitoring can reasonably be expected to maintain the wetland soils and vegetation currently present in the wetlands.</p> <p>Vegetation sampling (plots, transects, or plotless techniques) to estimate cover, density, mortality, and invasive species.</p> | <p>channels will be directed to Water W rather than into the wetlands.</p> <p>If standards are not met:<br/>                     Select species that are better adapted to existing hydrologic conditions.<br/>                     Install additional plant material.<br/>                     Install protective collars to reduce herbivore damage.<br/>                     Control/reduce non-native invasive species.</p> |

<sup>a</sup> Indicates a key design standard to be determined from the as-built condition. These standards typically do not require ongoing monitoring.

<sup>b</sup> Normal rainfall will be based on the definition for 'most years' given in the ACOE Manual (Environmental Laboratory 1987) (i.e. annual precipitation in a normal year must be the same as or greater than precipitation in 5 years out of 10) or the average precipitation for a time period plus or minus 1 standard deviation of the mean.

<sup>c</sup> Pre-project vegetation and soil conditions are documented in the *Wetland Delineation Report* (Parametrix 2000b).

<sup>d</sup> See Table 4.3-1 for interim cover targets (i.e., from year 3 to year 15).

<sup>e</sup> See Table 4.3-2 for a list of invasive, non-native species to be monitored and controlled on the mitigation site.



Table 5.2-13. Monitoring schedule for the replacement drainage channels.

| Feature            | Method                                            | Frequency of Inspection                                       | Data Collection Year |   |   |   |   |   |   |   |   |   |    |    |   |   |
|--------------------|---------------------------------------------------|---------------------------------------------------------------|----------------------|---|---|---|---|---|---|---|---|---|----|----|---|---|
|                    |                                                   |                                                               | 0                    | 1 | 2 | 3 | 4 | 5 | 6 | 7 | 8 | 9 | 12 | 15 |   |   |
| Substrate          | Inspect for evidence of erosion or scouring       | Annually (May) or after 2-year storm during the first 3 years | X                    | X | X | X | X | X | X | X | X | X | X  | X  | X | X |
| Hydrology          | Inspect following flood events; measure base flow | Twice yearly (February/November)                              | X                    | X | X | X | X | X | X | X | X | X | X  | X  | X | X |
| Downslope Wetlands | Groundwater monitoring                            | Monthly                                                       | X                    | X | X | X | X | X | X | X | X | X | X  | X  | X | X |
| Buffer Vegetation  | Vegetation sampling                               | Annually (late spring or early summer)                        | X                    | X | X | X | X | X | X | X | X | X | X  | X  | X | X |

### 5.2.3.10 Maintenance and Contingency Plans

Routine maintenance and contingency measures will be implemented for the replacement drainage channels consistent with the overall approach outlined in Section 4.

Specific contingency measures for the drainage channels are provided in Table 5.2-12. If flow rates and hydrology are substantially different from the design flows used to develop this plan, the channels may not function as designed and the channel section can be modified by:

- Widening the base flow channel to reduce velocities and improve capacity.
- Narrowing the base flow channel with logs or boulders to increase base flow depth and velocity.
- Widening the flood flow portion of the channel (above 0.5 ft) to improve capacity and reduce velocity.
- Adding log weir steps to flatten stream slope, reducing velocity and increasing base flow depth.
- Adjusting discharge points to Wetlands A13, 18, 37a, 39, 44a, and R9 or other wetlands as necessary.

### 5.2.4 Wetland Restoration Plan for Temporary Construction Impacts

Construction of the third runway embankment will result in some temporary wetland impacts (described in Section 5.2.4.2). Temporary impacts to wetlands are those that do not involve permanent filling or excavation, and include clearing of wetland vegetation; use of a wetland for temporary construction of access roads, staging areas, or temporary stormwater management ponds; or minor disturbances associated with placement of barrier and sediment fencing. Temporary impacts will last 1 to 5 years<sup>28</sup>. A maximum of 2.05 acres of wetlands (including 1.15 acres of forest, 0.46 acre of shrub, and 0.44 acre of emergent wetland) may be impacted temporarily by construction activities (Table 5.2-14). However, not all of these wetlands will necessarily be impacted by construction activities. During construction, all practicable means will be used to minimize and avoid temporary impacts (for example, reducing staging area or access road footprints, minimizing pond sizes, or re-routing access roads). Therefore, actual temporary construction impacts may be less than 2.05 acres. All wetlands temporarily impacted by construction activities will be restored and monitored to ensure performance standards are met (Table 5.2-15).

Following construction, wetlands temporarily impacted by clearing or filling will be restored by removing all temporary fill material, re-establishing pre-disturbance conditions, and planting with native forested and shrub vegetation. Wetlands with only minor disturbances that do not involve clearing of vegetation or filling (e.g., sediment fencing placed along the edge of a wetland) will be restored by removing sediment fencing, removing any other construction debris, and replacing any wetland vegetation disturbed by these activities.

---

<sup>28</sup> The temporal loss of wetland functions that can result from temporary impacts that exceed 1 year is mitigated by provided additional mitigation (at Wetland A17 and other locations).

Additionally, other temporary impacts to wetlands will occur during mitigation activities (see Section 5.2.4.2).

**Table 5.2-14. Summary of wetlands subject to temporary construction-related impacts.**

| Wetland                             | Classification <sup>a</sup>        | Total<br>Temporary<br>Impact Area<br>(acres) | Vegetation Type Impacted (acres) |             |             |
|-------------------------------------|------------------------------------|----------------------------------------------|----------------------------------|-------------|-------------|
|                                     |                                    |                                              | Forest                           | Shrub       | Emergent    |
| <b>Runway Safety Area Extension</b> |                                    |                                              |                                  |             |             |
| 4                                   | Forest <sup>b</sup>                | 0.20                                         | 0.20                             | 0.00        | 0.00        |
| 5                                   | Forest /Shrub <sup>b</sup>         | 0.20                                         | 0.10                             | 0.10        | 0.00        |
| 9                                   | Forest/Emergent                    | 0.16                                         | 0.11                             | 0.00        | 0.05        |
| <b>Third Runway</b>                 |                                    |                                              |                                  |             |             |
| 18                                  | Forest/Shrub/Emergent              | 0.22                                         | 0.04                             | 0.07        | 0.11        |
| 37                                  | Forest/Shrub/Emergent              | 0.71                                         | 0.50                             | 0.10        | 0.11        |
| 44a                                 | Forest/Shrub                       | 0.28                                         | 0.18                             | 0.10        | 0.00        |
| A1                                  | Forest/Shrub/Emergent <sup>b</sup> | 0.05                                         | 0.01                             | 0.01        | 0.03        |
| A12                                 | Shrub                              | 0.03                                         | 0.00                             | 0.03        | 0.00        |
| A13                                 | Forest                             | 0.01                                         | 0.01                             | 0.00        | 0.00        |
| R2                                  | Emergent                           | 0.02                                         | 0.00                             | 0.00        | 0.02        |
| <b>South Aviation Support Area</b>  |                                    |                                              |                                  |             |             |
| 52                                  | Forest/Shrub/Emergent <sup>b</sup> | 0.17                                         | 0.00                             | 0.05        | 0.12        |
| <b>TOTAL</b>                        |                                    | <b>2.05</b>                                  | <b>1.15</b>                      | <b>0.46</b> | <b>0.44</b> |

<sup>a</sup> All wetlands are palustrine, based on USFWS wetland classification system (Cowardin et al. 1979).

<sup>b</sup> Temporary impacts will be limited to installation of sediment fencing and other standard BMPs such as temporary seeding, straw mulch, interception swales, etc.

**Table 5.2-15. Mitigation design objectives and criteria for restoration of temporary wetland impacts.**

| Goal and Design Objectives                                                    | Design Criteria                                                                                                                                                                                  |
|-------------------------------------------------------------------------------|--------------------------------------------------------------------------------------------------------------------------------------------------------------------------------------------------|
| Restore wetlands to pre-construction conditions.                              | Grade areas to pre-construction elevations if pre-construction grades have been modified, amend soils with topsoil.                                                                              |
| Provide wetland hydrology appropriate for each wetland vegetation cover type. | Grade to re-establish pre-construction hydrology.                                                                                                                                                |
| Re-vegetate impacted wetland areas.                                           | Restore impacted areas with native forest vegetation. Emergent wetland communities will be replanted with forest vegetation to increase wetland functions and reduce potential use by waterfowl. |
| Stabilize soils in upland areas adjacent to restoration areas.                | Disturbed ground within 50 ft of the wetlands will be hydroseeded or otherwise stabilized to prevent erosion impacts to the wetland.                                                             |

#### **5.2.4.1 Goal, Objectives, and Design Criteria**

The primary goal of this plan is to ensure no net loss of wetland functions by restoring wetlands temporarily impacted by construction activities to their pre-construction size with an overall increase in function (e.g., replace non-native emergent vegetation with native forest vegetation).

Design objectives and design criteria were developed (see Table 5.2-15) to ensure that restoration goals have been met at the end of the 15-year monitoring program.

#### **5.2.4.2 Wetlands Site Description**

A total of 11 wetlands (see Table 5.2-14) may be temporarily disturbed by Master Plan Update project construction activities (see Figure 3.1-3; Appendix D, Sheets C2 and C3 through C7). These wetlands lie within three general project areas: the RSA and South 154<sup>th</sup> Street relocation, the third runway embankment, and the SASA. Wetlands subject to temporary construction-related impacts are listed in Table 5.2-14. A complete description of these wetlands is included in the *Wetland Delineation Report* (Parametrix 2000b).

##### **Runway Safety Areas and South 154<sup>th</sup> Street Relocation**

Wetlands 4 and 5 are located near the north end of the existing runways where required RSA extensions will be built. As part of the safety extensions, South 154<sup>th</sup> Street will be relocated several hundred feet to the north, adjacent to these wetlands. Temporary disturbance to small portions of Wetlands 4 and 5 (about 0.40 acre) could result from placement of silt fences and required temporary erosion and sediment control actions.

##### **Third Runway Embankment**

Eight wetlands occur near the edge of fill for the third runway embankment. Temporary disturbance will occur in portions of Wetlands A1 (0.05 acre), A12 (0.03 acre), A13 (0.01 acre), R2 (0.02 acre), and 18 (0.22 acre), outside the area of permanent fill. During the relocation of South 154<sup>th</sup> Street, portions (0.16 acre) of Wetland 9 will be temporarily disturbed by construction activity. Minor disturbance could occur in limited portions of these wetlands as a result of installing silt fences around the construction area.

In addition to the impacts described above, approximately 0.71 acre of Wetland 37 and 0.28 acres of wetland 44a will be directly disturbed from construction of temporary stormwater management facilities, including a temporary detention pond. The pond will be used to temporarily store construction stormwater that is pumped to an upland sedimentation pond. Design of these facilities has been planned to prevent indirect impacts to Wetland 37 and Wetland 44 as explained in Hart Crowser (2001a; Appendix Q). These stormwater facilities will be removed and the wetland area restored after completion of the third runway. Permanent stormwater facilities will be located outside of wetland areas.

##### **South Aviation Support Area**

Wetland 52 (i.e., Tyee Pond) is adjacent to the SASA project. Temporary impacts (approximately 0.17 acre) may occur during construction of the taxiway connecting the SASA to the airfield.

Impacts to the wetland could include minor sedimentation or soil disturbance resulting from construction.

#### **Temporary Impacts Resulting from Mitigation Projects**

Approximately 43.34 acres of wetland area (in both on- and off-site mitigation areas) will be subject to enhancement and restoration activities such as grading, weed control, and planting (see Table 3.1-4). In general, these activities occur to Category III or Category IV wetlands that are farmed or dominated by non-native vegetation. For example, approximately 3.74 acres of Wetland A1, a Category II riparian wetland, will be temporarily disturbed by construction associated with the relocation of Miller Creek, floodplain grading, and planting. Two emergent Category III wetlands at or near the off-site mitigation area in Auburn, Washington (see Sections 4 and 7) will be altered by the placement of temporary construction access roads or by excavation to increase the amount of seasonal saturation the wetland experiences. All of these wetlands will be enhanced or restored by the proposed mitigation actions, with an overall increase in wetland function resulting from the mitigation. These actions are described in detail in the sections discussing the individual mitigation projects.

#### **5.2.4.3 Rationale for Selection**

Those wetlands temporarily impacted from construction activities will be restored on-site. Mitigation of temporary impacts provides the opportunity to enhance or restore functions in wetlands that are currently degraded. Following mitigation of temporary impacts, these wetlands will be vegetated with native forest and shrub wetland species, and wetlands will be protected by 50-ft-wide upland buffers where possible.

#### **5.2.4.4 Constraints**

No significant constraints have been identified that would preclude implementing restoration plans for temporarily impacted wetlands.

#### **5.2.4.5 Ecological Assessment of the Mitigation Sites**

Ecological conditions in the temporarily impacted wetlands are discussed in detail in the *Wetland Delineation Report* (Parametrix 2000b). A general description of existing conditions in these wetlands is included in Section 2 of this report.

#### **5.2.4.6 Temporary Impact Mitigation Design**

Mitigation of temporary impacts varies on the nature of the impact, and specific mitigation plans are included in Appendix D. On completion of construction, all fill material and any construction material, equipment, or debris will be removed from the wetland.

The area will be regraded if necessary to re-establish pre-disturbance topography. Compacted soils will be loosened and amended with organic matter to obtain a suitable planting media. Soils retained for mitigation purposes that are stockpiled for more than 1 year will be treated with

microbial inoculants or through the addition of well decomposed organic matter. Where altered, wetland hydrology will be established in the wetland by directing seepage water to the wetlands via the drainage channels.

Wetlands subjected to minor temporary impacts (i.e., installation of sediment or barrier fencing does not require clearing of vegetation) will be restored by removing construction materials or debris. If any vegetation is disturbed by construction activities in these areas it will be replaced.

Finally, any areas outside of wetlands or wetland buffers that are disturbed by construction will be hydroseeded with an erosion control seed mix to stabilize the soils and prevent erosion. Hydroseeding will also provide ground cover and reduce the amount of habitat available for non-native weedy species that could affect the success of the wetland mitigation sites.

Mitigation plans for temporary wetland impacts will be coordinated as needed with the mitigation actions for the adjacent Miller Creek wetland and riparian buffer enhancement projects (Sections 5.2.1 and 5.2.2).

### **Wildlife Considerations**

Planting plans developed for the temporary impact mitigation are similar to those developed for the Miller Creek wetland and riparian buffer enhancement projects. These plans are consistent with the Port's WHMP and include species that are not likely to attract hazard wildlife (see Table 5.1-12; Appendix D, Sheet L1).

### **Landscape Plan**

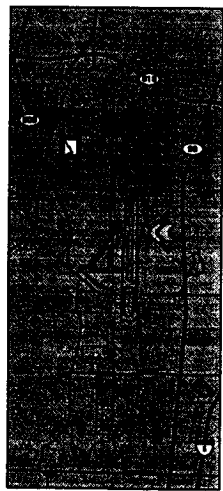
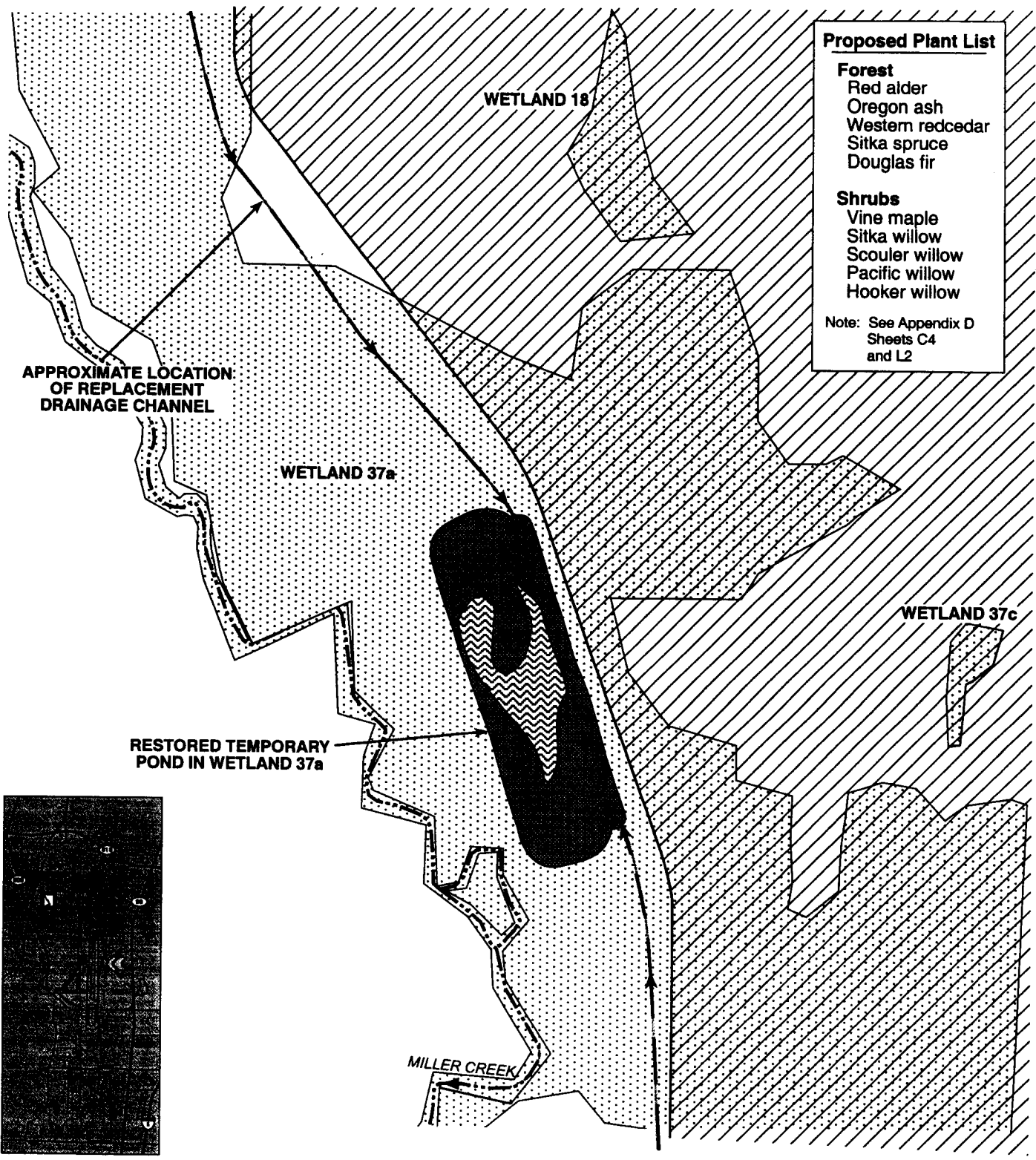
Native forest and shrub wetland vegetation will be restored by planting species such as Sitka spruce, black cottonwood, western redcedar, Pacific willow, Oregon ash, Pacific ninebark, and Sitka willow (Figures 5.2-17 and 5.2-18). Landscape plans for restoring temporarily disturbed wetland areas are shown in Appendix D, Sheet L1. A typical planting plan shows how the wetland areas will be replanted after construction is completed.

### **Expected Hydrology**

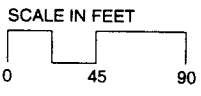
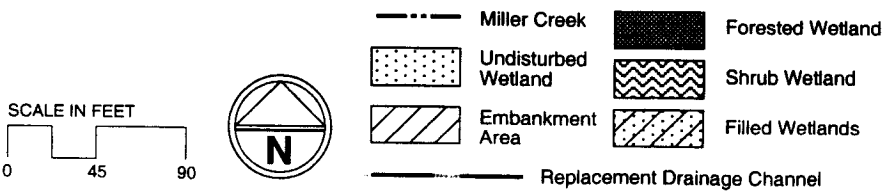
All temporarily impacted wetlands will be restored to pre-disturbance conditions (including topography) and therefore it is anticipated that hydrology in the restored wetlands will be similar to pre-construction conditions. The replacement drainage channel system is designed to ensure that hydrology in wetlands downslope of the embankment will be maintained. Performance standards and monitoring for wetlands downslope of the embankment are provided in Tables 5.2-11 and Table 5.2-12.

#### **5.2.4.7 Performance Standard and Contingency**

Performance standards, types of parameters measured, and contingency measures for temporary impact mitigation are listed in Table 5.2-16. The monitoring schedule for temporarily impacted mitigation sites is provided in Section 5.2.4.9.



Port of Seattle/Natural Resource Mitigation Plan/556-2912-001/01(03) 11/01 (K)



**Figure 5.2-17  
 Typical Planting Plan for  
 Wetland 37 Restoration of  
 Temporary Impact**

Riparian and Wetland Zone

RC Western Redcedar

A Red Alder

OA Oregon Ash

SW Scouler's Willow

SSp Sitka Spruce

HW Hooker's Willow

P Pacific Willow

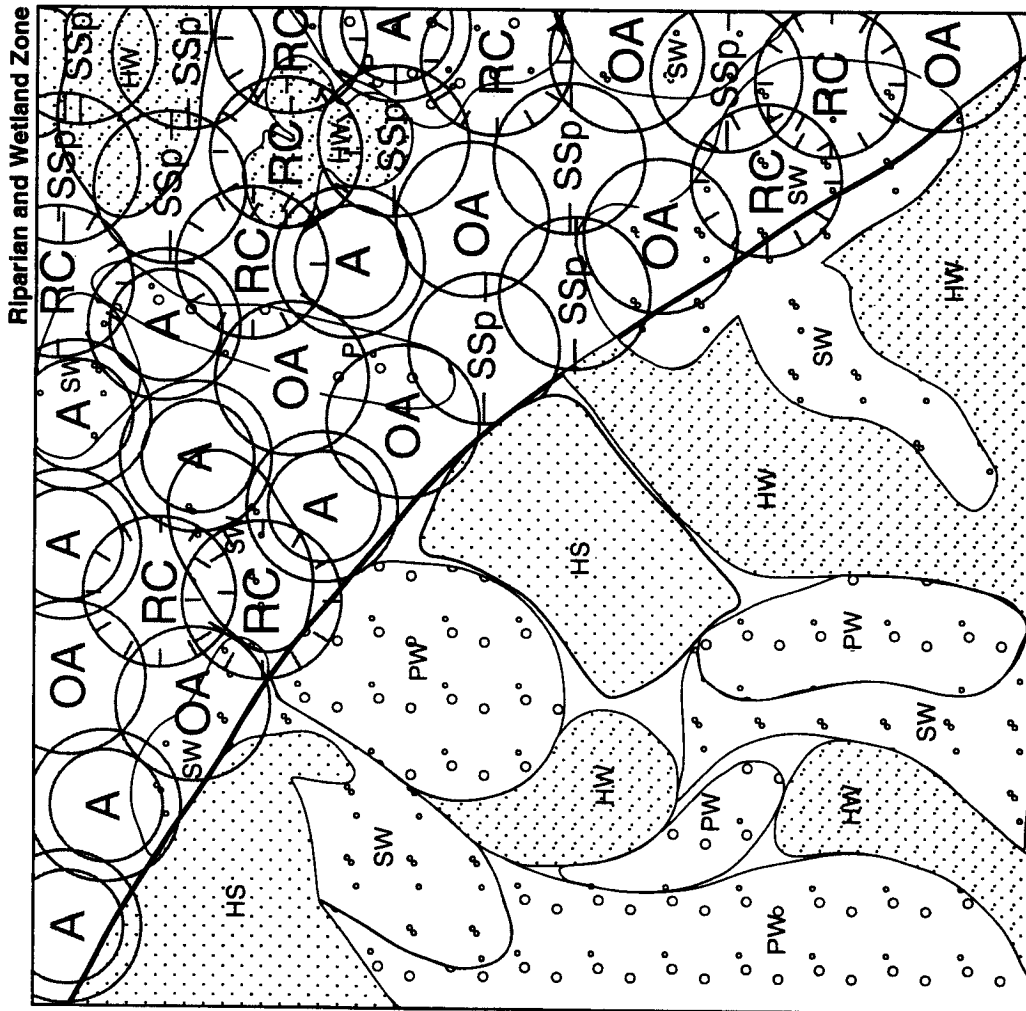
Shrub Wetland

SW Scouler's Willow

HW Hooker's Willow/Sitka Willow

PW Pacific Willow

HS Hardhack Spirea



Note: See Appendix D, Sheet L1

Part of Seattle/Natural Resource Mitigation Plan/556-2912-001/01(03) 9/01 (K)

Figure 5.2-18  
Typical Planting Plan  
for Restoration of Temporary  
Wetland Impacts



## **Vegetation**

Temporarily impacted wetlands that are replanted will be restored as palustrine forested wetlands and therefore will be monitored for at least 15 years. Vegetation will be monitored using the approach outlined in Table 5.2-16 and consistent with the requirements of Ecology (2001a).

### **5.2.4.10 Site Protection**

Areas subjected to temporary impacts will be protected as established in the restrictive covenants (Appendix G) and other federal, state, and local regulations that protect wetlands.

### **5.2.4.11 Maintenance and Contingency Plans**

Routine maintenance and contingency measures will be implemented for the temporarily impacted mitigation sites consistent with the overall approach outlined in Section 4.

Contingency measures for each performance standard for the temporary impact mitigation projects are listed in Table 5.2-16. Contingency measures will be consistent with the adaptive management approach outlined in Section 4.

### **5.2.4.12 Implementation of Replacement Drainage Channel and Temporarily Impacted Mitigation Projects**

The locations of the wetlands subject to temporary impacts and drainage channel mitigation sites are shown in Appendix D. Implementation of mitigation activities for temporarily impacted wetlands is dependent on phasing for construction of the third runway embankment and decommissioning of temporary stormwater detention ponds for the runway embankment construction. Drainage channel construction will occur before and during construction of the embankment (approximately 2000 to 2005). Temporary wetland impact restoration will occur immediately after completion of individual projects impacting wetlands (i.e., South 154<sup>th</sup> Street relocation embankment).

Prior to the start of construction, a pre-construction meeting between the contractor, engineer, and wetland scientist will determine the exact areas needed for construction activities. These temporary construction impact areas will be located to avoid and minimize impacts to wetlands. Construction limits will be clearly marked in the field to avoid impacts to wetlands outside the temporarily impacted areas.

Following construction, all construction debris and equipment will be removed from temporarily impacted areas. Any temporary access roads will be removed. Any fill material will be removed. Temporarily impacted areas will be returned to pre-disturbance conditions and drainage channels will be graded per specifications (Appendix D, Sheets C9 and L1). Soils that have been compacted by construction activities will be deep ripped if necessary, and will be tilled to a depth of 10 to 14 inches to provide suitable conditions for planting. Disturbed areas will be hydroseeded to stabilize the soil and native plant species installed to establish forested wetland vegetation (Appendix D, Sheets C9 and L1). Planting will occur during the early fall following temporary mitigation or drainage channel construction. Sediment and erosion control measures may be removed 1 full year after planting if these sites are stable. Replacement drainage channel buffers will also be planted with native trees and shrubs. Temporarily impacted and drainage channel mitigation sites will be monitored annually for a period of 15 years to ensure they are meeting performance standards.

### **5.2.5 Miller Creek Basin Trust Fund for Watershed Rehabilitation**

To provide opportunities for additional restoration projects in the Miller Creek basin, the Port will establish a trust fund to support watershed rehabilitation projects. The trust fund will focus on portions of Miller Creek not owned by the Port, and where the Port is unable to independently implement stream enhancement projects. The Port will make these trust funds available and defer the selection of appropriate projects to other governmental agencies or interested groups. Restoration or enhancement projects supported by the trust fund are independent of the environmental review and permit process for Master Plan Update projects (e.g., CWA 404/401, HPA), and may require local, state, or federal permits and environmental review.

#### **5.2.5.1 Goal**

The goal of this mitigation action is to provide a funding source to local agencies and groups to enhance instream or riparian habitat for salmonids and other aquatic organisms in the Miller Creek basin.

#### **5.2.5.2 Description**

The trust fund for watershed restoration will provide \$150,000 for restoration projects in the Miller Creek basin. Potential projects eligible for funding by the trust fund are based on information provided in the Stream Survey Report for Miller Creek (Appendix F of the Final EIS for the Master Plan Update Projects [Port of Seattle 1997]). The projects identified in Table 5.2-18 are a preliminary list and are proposed to address habitat problems in Miller Creek identified in the stream survey. Examples of projects eligible for full or partial funding could include instream fisheries habitat improvements similar to those proposed for Miller Creek in this plan (see Figures 5.2-8 through 5.2-11), riparian buffer enhancement, removal of fish passage barriers, and removal of failed septic systems.

While specific projects are not selected, a suite of potential projects is identified with their respective goals, general performance standards, and general monitoring requirements. Additional planning and engineering of selected projects will result in specific project designs, performance standards, monitoring requirements, and contingency measures. Project proponents will be responsible for obtaining any federal, state, or local permits required to implement the projects.

The trust fund will have a sunset period of 5 years, with the 5-year period beginning once permits are issued for the Master Plan Update projects. If after a 5-year period trust fund projects are not designed and environmental permits sought,<sup>29</sup> the Port will use the money to implement projects in the Miller Creek basin that would provide water quality or aquatic habitat benefits. The projects to be implemented will be at the discretion of the Port, but with approval from Ecology and ACOE.

---

<sup>29</sup> Project proponents will be responsible for obtaining all federal, state, and local permits required to implement habitat enhancement projects.

**Table 5.2-16. Final performance standards, evaluation measures, and contingency measures for restoration of temporary wetland impacts.**

| Design Criteria                                                                                                                                                                                     | Performance Standard                                                                                                                                                                                                                                                                                                                                                                                                                                                                                                                                                                                                                                                                                                                                                                                                                                                                              | Evaluation Methods                                                                                                                                                                                                          | Contingency Measures                                                                                                                                                                                                                                                                                                                                                                |
|-----------------------------------------------------------------------------------------------------------------------------------------------------------------------------------------------------|---------------------------------------------------------------------------------------------------------------------------------------------------------------------------------------------------------------------------------------------------------------------------------------------------------------------------------------------------------------------------------------------------------------------------------------------------------------------------------------------------------------------------------------------------------------------------------------------------------------------------------------------------------------------------------------------------------------------------------------------------------------------------------------------------------------------------------------------------------------------------------------------------|-----------------------------------------------------------------------------------------------------------------------------------------------------------------------------------------------------------------------------|-------------------------------------------------------------------------------------------------------------------------------------------------------------------------------------------------------------------------------------------------------------------------------------------------------------------------------------------------------------------------------------|
| 1. Grade disturbed areas to pre-construction elevations, and hydrologic conditions.                                                                                                                 | Pre-disturbance wetland topography is restored.                                                                                                                                                                                                                                                                                                                                                                                                                                                                                                                                                                                                                                                                                                                                                                                                                                                   | Comparison of pre- and post-construction topography.                                                                                                                                                                        | Regrade if necessary.                                                                                                                                                                                                                                                                                                                                                               |
| 2. Restore impacted areas with native forest vegetation. Emergent wetland communities will be replanted with forest vegetation to increase wetland functions and reduce potential use by waterfowl. | Wetland areas will meet wetland criteria (hydrophytic vegetation, hydric soils, hydrology) following restoration (see Table 5.2.12).<br><br>In revegetated areas, survival will be 100% at the end of year 1; average survival of planted stock will be at least 80% during the first 3 monitoring years. Cover of native species will be at least 80% by the end of the 15-year monitoring period <sup>a</sup> .<br><br>Cover of non-native invasive <sup>b</sup> species in newly planted or enhanced areas will be no more than 10% during any monitoring year.<br><br>In monitoring years 3, 8, and 15-revegetated wetlands will have a tree density of at least 280 per acre and a shrub density of at least 2,100 individuals per acre.<br><br>In monitoring years 3, 8, and 15, plant diversity will not decrease by more than 10% from the number of plant species installed at baseline. | Monitor the depth to and the duration of soil saturation (see Table 5.2.12).<br><br>Vegetation sampling (plots, transects, or plotless techniques) to estimate mortality, cover, density, and presence of invasive species. | Regrade if necessary.<br><br>Use water collected by drainage channels to supplement wetland hydrology.<br><br>If standards are not met:<br><br>Select species that are better adapted to existing hydrologic conditions.<br><br>Install additional plant material.<br><br>Install protective collars to reduce herbivore damage.<br><br>Control/reduce non-native invasive species. |
| 3. Disturbed ground within 50 ft of the wetlands will be hydroseeded or otherwise stabilized to prevent erosion impacts to the wetland.                                                             | Vegetation cover within 50 ft of wetlands will exceed 80 percent within 1 year following restoration.                                                                                                                                                                                                                                                                                                                                                                                                                                                                                                                                                                                                                                                                                                                                                                                             | Measure plant cover using standard vegetation sampling techniques.                                                                                                                                                          | Install erosion control fabric.<br><br>Install additional hydroseed or plants in upland areas.                                                                                                                                                                                                                                                                                      |

<sup>a</sup> See Table 4.3-1 for interim cover targets (i.e., from year 3 to year 15).

<sup>b</sup> See Table 4.3-2 for list of invasive, non-native species to be monitored and controlled on the mitigation site.

### 5.2.4.8 Implementation

Temporary impact mitigation projects will be coordinated with third runway construction activities, as well as with Miller Creek riparian wetland and buffer enhancement projects. Implementation of the replacement drainage channels and the temporary impact mitigation is described in Section 5.2.4.12 below.

### 5.2.4.9 Monitoring and Performance Standards

The overall monitoring approach for temporary impact mitigation will be consistent with the monitoring approach outlined for all Master Plan Update mitigation projects in Section 4 of this plan. Monitoring tasks specific to the temporary impact mitigation projects are described in this section. Performance standards, methods and parameters, and contingency measures for the temporary impact mitigation are listed in Table 5.2-16. The monitoring schedule for temporarily impacted mitigation sites is provided in Table 5.2-17.

**Table 5.2-17. Monitoring schedule for restoration of temporary wetland impacts.**

| Feature                | Activity               | Frequency                                       | Data Collection Year |   |   |   |   |   |   |   |   |   |    |    |    |
|------------------------|------------------------|-------------------------------------------------|----------------------|---|---|---|---|---|---|---|---|---|----|----|----|
|                        |                        |                                                 | 0                    | 1 | 2 | 3 | 4 | 5 | 6 | 7 | 8 | 9 | 10 | 12 | 15 |
| Wetland hydrology      | Groundwater monitoring | Twice Monthly                                   | X                    | X | X | X |   |   |   |   |   |   |    |    |    |
|                        |                        | Monthly                                         |                      |   |   |   | X | X |   |   |   | X |    | X  |    |
|                        |                        | Once winter, late spring/early summer, and fall |                      |   |   |   |   |   | X | X | X | X |    | X  | X  |
| Vegetation communities | Vegetation sampling    | Once late spring or early summer                | X                    | X | X | X | X | X |   |   |   | X | X  | X  |    |
|                        | Wetland Delineation    | Once in spring                                  |                      |   |   |   |   | X |   |   |   | X |    | X  |    |
| Reports                |                        |                                                 | X                    | X | X | X | X | X | X |   |   | X | X  | X  |    |

### Hydrology

Monitoring of temporarily impacted wetlands, as well as wetlands between the embankment and Miller Creek, will include evaluating wetland hydrology. To ensure that performance standards are met, and to aid in determining appropriate contingency measures, monitoring will include a pre-construction topographic survey and groundwater monitoring. A topographic survey of all wetlands within the temporarily impacted area will be conducted before grading for the runway embankment. This survey will be used as a baseline to re-establish pre-construction contours. Shallow groundwater monitoring wells will be installed within restored wetlands following grading and planting. Groundwater levels will be monitored at least monthly to determine presence of wetland hydrology sufficient to maintain existing or planted vegetation. This monitoring will be consistent with the requirements established by Ecology (2001a).

**Table 5.2-18. Potential trust fund projects in the Miller Creek watershed.**

| <b>Project</b>                            | <b>Goals</b>                                                                                                                                                                                  | <b>Description</b>                                                                                                                                                                  | <b>Performance Standards</b>                                                                                                                    | <b>Monitoring</b>                                                                                                                                                                   |
|-------------------------------------------|-----------------------------------------------------------------------------------------------------------------------------------------------------------------------------------------------|-------------------------------------------------------------------------------------------------------------------------------------------------------------------------------------|-------------------------------------------------------------------------------------------------------------------------------------------------|-------------------------------------------------------------------------------------------------------------------------------------------------------------------------------------|
| Pool Habitat Improvements (RM 2.0 to 3.3) | Increase high-flow refugia and over-wintering habitat for resident and anadromous fish species.                                                                                               | Modify stream channel to increase size, depth, and cover of existing pools.<br>Create additional pools through placement of LWD complexes (4 to 6 logs each) in the stream channel. | Established pools and riffles will remain stable, or pool/riffle ratio shall remain within 10% of established value over 10 years.              | Assess functions of pool/riffle complex annually at the end of the wet season to determine habitat quality of existing and created pools.                                           |
| Streambank Stabilization (RM 2.0 to 3.3)  | Increase quality spawning gravels and escape cover for juvenile salmonids and habitat for aquatic invertebrates by increasing stability of streambanks prone to slump and landslide activity. | Apply prescriptive stabilization designs to eroding banks, landslide areas, slumps, and debris jams that are major contributors to sediment loading.                                | Streambank stabilization projects shall remain intact for the 15-year monitoring period.                                                        | Assess stabilized streambanks annually at the end of the wet season, noting soil stability, evidence of sediment loading in the stream channel, and potential for sediment loading. |
| Streambank Re-vegetation (RM 2.0 to 3.3)  | Decrease seasonal water temperature fluctuation through shading stream channel with native vegetation.                                                                                        | Install native riparian vegetation to provide overhead cover and shading of stream channel.                                                                                         | Installed plant materials shall have minimum 80% survival after 3 years, and shall provide a minimum of 80% cover of native species by year 10. | Assess installed plant materials and percent cover of non-native invasive vegetation species annually at the end of the growing season.                                             |

### **5.2.5.3 Eligibility**

The Port or the designated administrator of the trust fund will consider requests for monies from the watershed trust fund to implement stream habitat enhancement projects. Requests must be made by King County, City of SeaTac, City of Des Moines, City of Burien, City of Normandy Park, special districts, tribal governments, non-profit organizations, or combinations of such governments through inter-local agreements. Organizations requesting funding must comply with general liability insurance requirements established by the Port.

Key criteria to be used to evaluate proposals to implement projects in Table 5.2-18, as well as other projects within the watershed, are:

- A demonstrated benefit to salmon or aquatic habitat without creating significant avian wildlife habitat within 10,000 ft of runways at STIA.
- Consistency with watershed management plans, or with prescriptions/recommendations identified using watershed analysis or stream assessment procedures.
- Clearly defined project goals, implementation plans, performance standards, and post-project monitoring.
- Preference for resolving underlying causes of problems rather than treating symptoms.
- Cost-effectiveness.

### **5.2.5.4 Implementation**

The Miller Creek Basin Committee, the King County Watershed Coordinator, Puget Sound Restoration Fund, or other responsible entity will administer the fund. The administrator will establish eligible project criteria, set project cost limits, and set implementation and monitoring requirements. The Port will review and approve project goals, plans, performance standards, and monitoring requirements to enhance the ultimate success of the projects. The Port or the administrator at the Port's request, will provide status reports to Ecology and ACOE.

### **5.2.5.5 Site Protection**

Site protection measures for enhancement projects will be coordinated with property owners and the fund administrator.

### **5.2.5.6 Monitoring and Contingency Plans**

The fund administrator will review project design, implementation, and as-built plans to verify that intended benefits have been built. Contingency actions associated with establishment or operation of the fund will be reviewed with the Port, ACOE, Ecology, and the fund administrator.



### **5.3 DES MOINES CREEK BASIN RESTORATION PROJECTS**

Master Plan Update improvement projects will result in approximately 3.88 acres of permanent wetland impacts in the Des Moines Creek basin (Borrow Area 1, Haul Road, and SASA; see Table 3.1-2). These unavoidable impacts will result from development of the SASA and excavation in the borrow areas. Therefore, to mitigate these impacts in the Des Moines Creek basin, the Port proposes restoration and enhancement projects designed to increase wetland function, enhance aquatic habitat, and improve stream conditions within Des Moines Creek. These mitigation projects are designed to ensure that new wildlife hazards are not created near the airport. This integrated set of projects is designed to meet the following overall objectives:

- Restore wetland functions to a portion of the Tye Valley Golf Course by restoring a native wetland shrub community (Section 5.3.1).
- Enhance aquatic habitat and improve stream functions by restoring a forested riparian buffer along a 870-ft of the west branch of Des Moines Creek, also located on the Tye Valley Golf Course (Section 5.3.1).
- Establish a \$150,000 trust fund for restoration projects located in the Des Moines Creek basin (Section 5.3.2).
- Provide for additional stream enhancement projects and local restoration efforts.
- Provide hydrologic mitigation to wetlands in Borrow Areas 1 and 3 (Section 5.3.3).

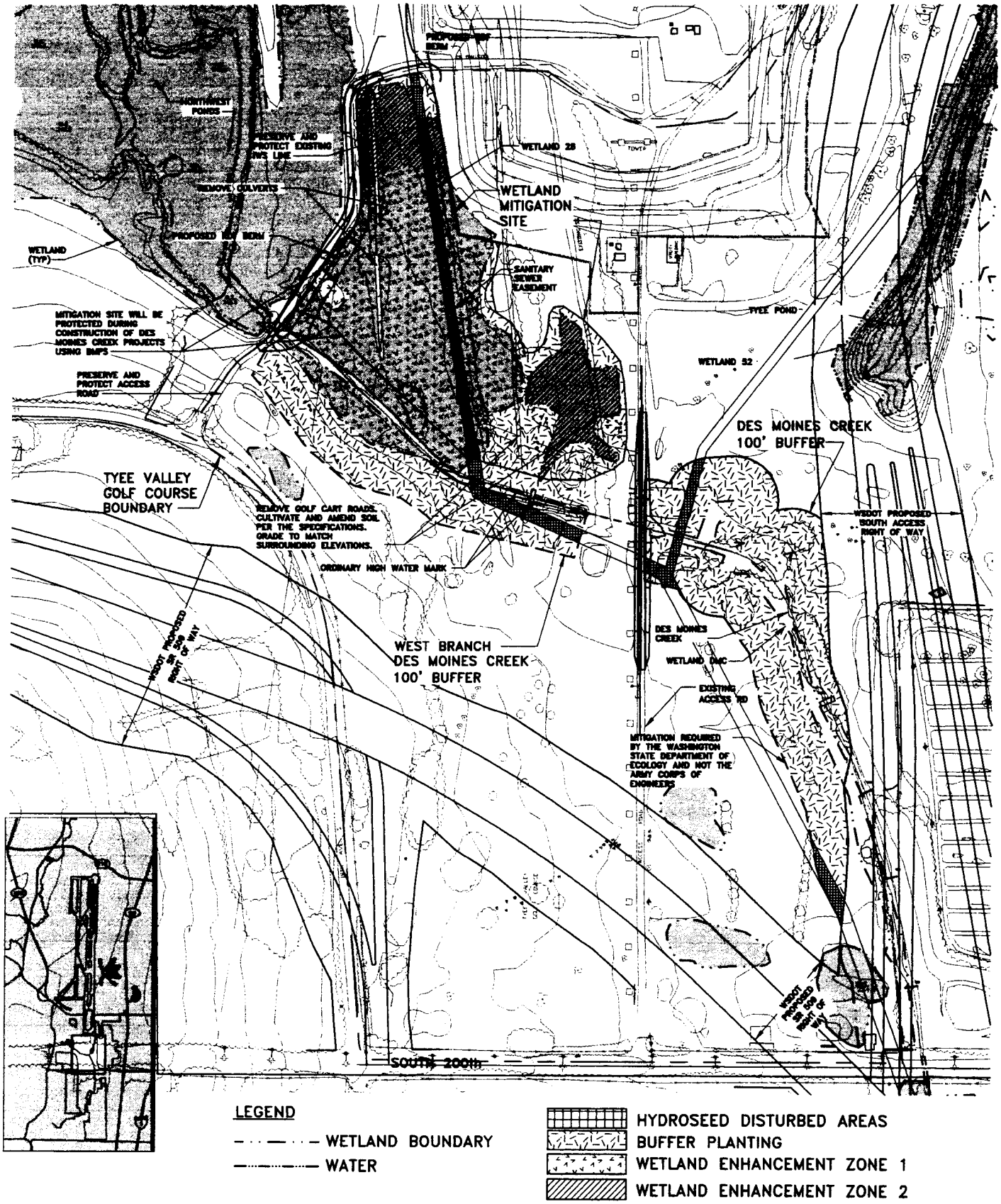
To provide additional protection to Des Moines Creek, the Port will plant a 100-ft buffer along Des Moines Creek from the edge of the wetland mitigation site at the Tye Valley Golf Course south to the proposed South Access Freeway ROW.

#### **5.3.1 Tye Valley Golf Course Area Mitigation Plans**

Projects in the Des Moines Creek basin are designed to mitigate unavoidable project impacts to wetlands and aquatic resources by restoring wetland and stream functions. To mitigate wetland impacts and improve aquatic habitat in the Des Moines Creek watershed, existing emergent wetland at the Tye Valley Golf Course will be enhanced by establishing a native shrub wetland community (Figure 5.3-1). Approximately 4.5 acres of wetland in the Tye Valley mitigation area and approximately 1.0 acre in the west branch Des Moines Creek buffer will be enhanced. This mitigation will increase infiltration, reduce pollutant runoff, increase sediment retention, improve nutrient cycling functions in the wetland, and improve water quality and habitat in adjacent Des Moines Creek. Replacing the existing golf course turf grass by planting a native shrub community will also decrease hazard wildlife attractants within 10,000 ft of the airfield (as required by the FAA) by reducing waterfowl use of the golf course.

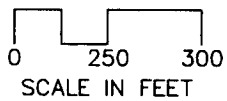
To enhance water quality and aquatic habitat in Des Moines Creek, approximately 5 acres of buffers will be established along Des Moines Creek at the Tye Valley Golf Course (see Table 4.1-3). A 100-ft buffer (approximately 3.4 acres) on both sides of the west branch of Des Moines Creek (see Figure 5.3-1) and approximately 1.6 acres within the Tye Valley Golf Course mitigation area will be enhanced. These buffers will be planted with native forested and shrub riparian vegetation. Species planted in the buffer will be selected to avoid attractants to hazard wildlife, consistent with the Port's WHMP.





FILE: 291203\_F5  
 DATE: 11/15/01

REFERENCE: NRMP 2000



**Figure 5.3-1**  
**Location of Wetland Enhancement**  
**On the Tye Valley Golf Course,**  
**Des Moines Creek Basin**

AR 049261

Enhancement of this buffer will increase infiltration in the buffer area; reduce sediment, nutrient, and pollutant inputs to the stream; and provide shade, LWD, and organic matter inputs to Des Moines Creek.

**5.3.1.1 Goals, Objectives, and Design Criteria**

The following section describes the goals, objectives, and design criteria identified for the Des Moines Creek projects. Goals identified for this plan include:

- Establish a total of 5.5 acres of native shrub wetland in a currently degraded emergent wetland (i.e., golf course turf). This action will improve water quality, fish habitat, and stream conditions in Des Moines Creek (4.5 acres in Tyee Valley Golf Course mitigation area and about 1.0 acre in west branch Des Moines Creek buffer; see Table 4.1-3).
- Reduce hazard wildlife (e.g., Canada goose and other waterfowl species) use of the golf course area by replacing turf grass wetland with shrub wetland.
- Improve water quality and aquatic habitat in Des Moines Creek by planting a 100-ft forested buffer along both banks of an 870-ft section of Des Moines Creek adjacent to the wetland mitigation.
- Improve water quality and aquatic habitat along other areas of Des Moines Creek that are outside the proposed SR 509 ROW.

Specific design objectives and criteria developed to ensure that the Des Moines Creek projects meet mitigation goals are listed in Table 5.3-1.

**Table 5.3-1. Mitigation goals, design objectives, and design criteria for wetland and buffer enhancement on the Tyee Valley Golf Course.**

| Goals and Design Objectives                                                                                                  | Design Criteria                                                                                                                                                                                                                  |
|------------------------------------------------------------------------------------------------------------------------------|----------------------------------------------------------------------------------------------------------------------------------------------------------------------------------------------------------------------------------|
| <b>Goal 1: Enhance degraded wetlands to provide improved water quality and aquatic habitat functions to Des Moines Creek</b> |                                                                                                                                                                                                                                  |
| Enhance existing turf-dominated wetland at the Tyee Valley Golf Course.                                                      | Plant 5.5 acres of the golf course wetland with native wetland shrub species (include wetland area on left and right bank west branch Des Moines Creek).<br><br>Shrub and small tree density will be 3,375 individuals per acre. |
| <b>Goal 2: Reduce waterfowl use of the golf course area</b>                                                                  |                                                                                                                                                                                                                                  |
| Reduce habitat value of the mitigation area for waterfowl.                                                                   | Plant area with shrub vegetation to discourage use of wetland by waterfowl, improving aircraft safety.                                                                                                                           |
| <b>Goal 3: Improve water quality and aquatic habitat in Des Moines Creek by restoring riparian buffers.</b>                  |                                                                                                                                                                                                                                  |
| Establish and protect 100-ft-wide riparian buffers.                                                                          | Plant 100-ft-wide riparian buffers on each side of Des Moines Creek (approximately 3.38 acres of buffer area).<br><br>Plant native riparian forested and shrub plant species within the 100-ft buffer along Des Moines Creek.    |

### **5.3.1.2 Mitigation Site Descriptions**

#### **Tyee Valley Golf Course**

The Tyee Valley Golf Course is an active golf course located at the southern end of the STIA runways (see Figure 2.1-1). The golf course occurs in the eastern portion of Wetland 28, an approximately 35-acre wetland complex associated with the Northwest Ponds and the west branch of Des Moines Creek. The portion of the wetland associated with the Northwest Ponds (west of the golf course) contains forest, shrub, emergent, and open-water wetland habitat. The golf course portion of Wetland 28 contains an approximately 9.75-acre emergent turf grass wetland. Wetland enhancement will occur in emergent turf grass wetland (see Figure 5.3-1). A detailed description of Wetland 28 is provided in the *Wetland Delineation Report* (Parametrix 2000b).

#### **Des Moines Creek**

The west branch of Des Moines Creek originates at the Northwest Ponds or Wetland 28 (see Figure 2.1-3). The Northwest Ponds, located southwest of the existing runways between South 192<sup>nd</sup> Street and South 196<sup>th</sup> Street, were excavated as a source of peat by the previous property owners, and subsequently incorporated into the airport's stormwater management system. The east fork of Des Moines Creek originates in Bow Lake, east of the airport, and flows south, mostly via closed pipes, to the Tyee Valley Golf Course detention pond (Tyee Pond; Wetland 52). From Tyee Pond, the east branch flows through a culvert to join the west branch of the creek southeast of the proposed wetland mitigation site (see Figure 5.3-1). South of the confluence, Des Moines Creek flows through the Tyee Valley Golf Course to South 200<sup>th</sup> Street and then generally south to Puget Sound.

### **5.3.1.3 Ownership**

The Port owns the property in the Des Moines Creek mitigation areas (i.e., golf course, buffer zone of Des Moines Creek). The golf course is currently leased to a golf course operation, which will cease operations before implementation of the mitigation plan.

### **5.3.1.4 Rationale for Selection**

The Des Moines Creek mitigation projects provide an opportunity to mitigate wetland impacts on-site in the Des Moines Creek basin. Mitigation will occur by restoring portions of a historic peat wetland adjacent to the upper reaches of Des Moines Creek, enhancing riparian buffers along Des Moines Creek, and mitigating potential indirect impacts to wetlands downslope of the project area.

Historic land uses have resulted in converting a native peat wetland to a golf course, as well as replacing forested wetlands and riparian areas along Des Moines Creek with open turf grass areas or areas of non-native invasive species. These alterations have degraded aquatic habitat in Des Moines Creek, increased sediment and nutrient inputs to the stream, and removed the buffering influence of riparian vegetation. Using the Tyee Valley Golf Course as a mitigation site provides a unique opportunity to enhance an existing wetland and restore a native wetland shrub habitat adjacent to a salmon-bearing stream. This mitigation site also provides the opportunity to improve the aquatic

habitat of Des Moines Creek by reducing pollutant runoff, increasing sediment retention, and increasing nutrient cycling by restoring both wetlands and riparian buffers along the stream.

Finally, the turf grass and seasonal flooding that occur on the Tye Valley Golf Course attract a large number of waterfowl (e.g., Canada geese and American widgeon) that forage on the mowed lawn of the golf course. These waterfowl pose a threat to aircraft operation and safety; establishing shrub vegetation will eliminate waterfowl from portions of the golf course and reduce aviation hazards.

#### **5.3.1.5 Constraints**

Mitigation design for these projects is constrained by the proximity of the mitigation sites to the airfield and runways. Proximity to the airfield affects the choice of plant species used in the design to ensure that wildlife hazards are not created. The size of buffer areas is constrained by nearby RSAs and embankments. Two separate and unrelated construction projects are also potential constraints that have affected the design and implementation of the Des Moines Creek projects. These projects are the King County RDF proposed at the Northwest Ponds and the Washington State Department of Transportation (WSDOT) SR 509 extension and South Access Freeway.

These constraints will not prevent the plan from being implemented, but they could affect implementation steps (e.g., construction sequencing) or design (e.g., protective barriers around mitigation plantings). In addition, concerns have been raised by ACOE and Ecology regarding the hydrology of the wetland mitigation area. Although this is not a constraint on the mitigation, these concerns are addressed in this section. Finally, there are no constraints on mitigation for indirect hydrology impacts at the borrow areas.

#### **Buffer Size**

Site constraints preclude the installation of extensive forested buffers around the wetland mitigation site. Within the wetland mitigation site itself, there are shrub buffers on the north side of the enhanced wetland edge and the surrounding golf course (Appendix C, Sheet C2). On the south side, 100-ft buffers along Des Moines Creek will protect the wetland mitigation site and the stream. Wetland buffers cannot be enhanced east of the wetland mitigation site because these areas are within designated RSAs and runway embankment. In this area, emergency and non-emergency access, flexibility to maintain or modify vegetation, vegetation height limits, and the flexibility to maintain or supplement navigation equipment or other airfield facilities must be retained for the safe operation of the airport. However, these restrictions will preclude high-impact uses near the wetland mitigation site, thereby providing an effective land use barrier.

#### **Wildlife Hazards**

The FAA and USDA-WSD staffs have evaluated the mitigation proposed for the Des Moines Creek basin for potential wildlife hazards to aviation. These agencies have determined that the mitigation results in a decrease in wildlife hazards near the airfield. New road construction (i.e., SR 509 extension and South Access Freeway) near the airport is not expected to increase wildlife hazards. Overall, modification of waterfowl habitat by the Port's mitigation (planting of existing emergent wetlands and buffers with shrub and forested vegetation) will reduce wildlife hazards.

## **Site Hydrology and Relationship to the King County/Des Moines Creek Regional Detention Facility**

### **Hydrology**

The Tyee Valley Golf Course wetland mitigation will occur on an existing peat wetland that historically supported forested and shrub vegetation. Existing soils and hydrology on the site would support forested or shrub wetland under existing conditions, in the absence of active measures to maintain the emergent turf grass vegetation of the golf course. Existing wetland conditions at the mitigation site are maintained by high groundwater and by precipitation during the winter months. Grading will not be necessary to create the hydrologic conditions necessary to restore shrub wetlands at the Tyee Valley Golf Course site because the site already has wetland hydrology sufficient to support native shrub wetlands.

### **Regional Detention Facility**

The Des Moines Basin Planning Committee identified a preferred alternative for the RDF in November 1999. The objective of the RDF is to control erosive flows reaching Des Moines Creek and thereby restore salmon habitat (King County Capitol Improvement Project Design Team 1999). The proposal includes increasing storage capacity in the Northwest Ponds and some channel reconstruction in Des Moines Creek to deepen the channel south of the wetland mitigation site.

Wetland hydrology of the mitigation site will not be affected by the operation of the RDF because hydroperiods within the mitigation site will not be significantly affected by the RDF. The Tyee Valley Golf Course currently is inundated by overbank flow from Des Moines Creek to some extent during flood events. The 100-year floodplain of Des Moines Creek (under existing conditions) is entirely within the mitigation site, and within the boundaries of Wetland 28 (Appendix C, Sheet C3). Construction of the RDF will result in a slight decrease in flooding on the mitigation site because of proposed reconstruction of the stream channel adjacent to the mitigation and increased water storage in Wetland 28.

Using data from the King County RDF plan (King County Capital Improvement Design Team 1999), King County compared current water levels on the mitigation site as a result of the 10-year, 25-year, and 100-year floods, with water levels predicted to occur during these flood events after construction of the RDF. In all cases, water levels and the extent of inundation on the site are somewhat lower with the proposed RDF than under current conditions (Appendix C, Sheets C3 and C4). For example, under existing conditions without the RDF, 100-year flood elevations are approximately at the 250.5-ft contour, while with the RDF, the 100-year flood elevations are a foot lower, at the 249.5-ft contour. Under existing conditions, inundation by the 100-year flood at the mitigation site is approximately 3.1 acres, while with the RDF in operation, the 100-year flood would inundate approximately 2.1 acres. Therefore, construction of the RDF will slightly decrease inundation of the site during flood events. However, because wetland hydrology on the site is not driven by flood events, this decrease will not affect implementation of the mitigation plan. Even with the slightly lower levels of inundation during flood events predicted after construction of the RDF, the Tyee site will support the planned wetland shrub vegetation. The site will continue to support wetland vegetation and hydrology because the current wetland is maintained by a high groundwater table that results in saturated soil conditions, and not by overbank flooding.

The preferred alternative for the RDF includes a berm adjacent to the west side of the Tyee Valley Golf Course mitigation site and enhancement of a portion of Des Moines Creek south of the wetland mitigation site (Appendix C, Sheet C2). The Port will protect the wetland mitigation site from RDF construction by placing sediment fencing or other TESC measures, and orange barrier fencing at the edge of the mitigation site to ensure that any potential impacts from construction are avoided. Protection will include ecology blocks or rock gabions to protect the wetland mitigation site during RDF construction to ensure that construction equipment does not enter the wetland mitigation site or riparian buffer.

Riparian buffer enhancement (the area extending a horizontal distance of 100 ft from the OHWM of the stream or from the edge of riparian wetlands, whichever is greater) along Des Moines Creek will be coordinated with construction of the RDF and will be planted by the end of 2004.

#### **SR 509 Extension/South Access Freeway**

The WSDOT SR 509 extension and South Access Freeway project will not constrain implementation of the Port's mitigation plan in the Des Moines Creek basin. These two projects involve extending SR 509 south of the proposed RDF and constructing an access road between SR 509 and the airport terminal ramps. All wetland mitigation has been designed to avoid conflicts with the preferred alternative for these projects.

The Port's proposed mitigation at the Tyee Valley Golf Course and along Des Moines Creek avoids the preferred alternative for SR 509 and the South Access Freeway (Appendix C, Sheet C2). Surface water runoff from these roadways can be collected, treated, and diverted to prevent runoff impacts to the mitigation sites. Therefore, these projects will not affect the hydrologic or riparian functions desired for the mitigation site.

#### **Other Utilities**

A concern for this mitigation area has been the presence of an IWS discharge line and sewer line easement owned by the Midway Sewer District. Occasional maintenance of this line will be required within the 20-ft easement, and this maintenance<sup>30</sup> could prevent mature vegetation from developing within the easement (see Appendix C, Sheet C2 for location of these lines). For these reasons, the area of the easement is removed from the mitigation buffer, and equivalent area that can be fully protected from future disturbance has been added to the mitigation area. As a result, the presence of the sewer line will not reduce or alter the ecological functions derived from the mitigation. Its presence has, in fact, increased the area of land set aside for protection.

---

<sup>30</sup> Sewer lines generally have a design life in excess of 50 years, and rarely require maintenance or fail. Therefore, the potential for disturbance of the easement area is small and infrequent. Furthermore, if leaks were to develop in the line, there are methods to repair and rehabilitate sewer lines in-situ with no disruption of surface soils. These methods employ installation of new pipe sleeves or pipe liners within the existing pipe. Installation is done through existing manholes without soil excavation. These are the preferred methods for rehabilitating sewer lines, and are routinely used by large and small sewer utilities. The easement width of 20 ft provides a sufficient construction work area for maintenance, repair, or replacement activities.

### 5.3.1.6 Ecological Assessment of the Mitigation Area

Detailed additional descriptions of wetlands, borrow areas, and Des Moines Creek in the mitigation projects area are provided in the *Wetland Delineation Report* (Parametrix 2000b). The following sections summarize the existing conditions of these areas.

#### Des Moines Creek

The west branch of Des Moines Creek originates at the Northwest Ponds and flows through the golf course to the confluence with the east branch; the main channel then flows south to Puget Sound. The channel and riparian zone of Des Moines Creek upstream of South 200<sup>th</sup> Street have been significantly altered as a result of golf course development. Des Moines Creek is on the 303(d) list for fecal coliform of unknown origin. The channel substrate in the reach of Des Moines Creek through the golf course is predominantly composed of sands and silts, with some scattered areas of gravels and cobble, and some areas of heavy accumulation of fine sediments. Riparian vegetation along Des Moines Creek in the golf course area is primarily turf grass. Between the confluence and South 200<sup>th</sup> Street, there is an approximately 25-ft-wide riparian zone vegetated with trees and shrubs. Existing riparian vegetation provides very little shade or organic matter inputs to Des Moines Creek.

#### Tyee Valley Golf Course Wetland (Wetland 28)

Historically, the Tyee Valley Golf Course was a peat wetland, most of which was farmed until about 1970. At this time, portions of the original wetland were converted to golf course and stormwater management ponds.

#### **Vegetation**

The proposed wetland mitigation site is located on an active golf course consisting primarily of fairways, greens, and roughs. Several roadways used for emergency access or golf cart roads are constructed on fill and cross the mitigation site. Vegetation on the Tyee Valley Golf Course is predominantly non-native turf grasses (e.g., *Poa* sp., *Agrostis* sp.), with scattered patches of coniferous and deciduous trees. No native wetland plant communities currently exist on the golf course. Portions of Wetland 28 to the west of the proposed mitigation site are dominated by native shrubs such as Pacific and Sitka willows and red elderberry (*Sambucus racemosa*), with some scattered trees such as black cottonwood and red alder.

#### **Soils**

In the golf course area of Wetland 28, the wetland soil is primarily a black or dark brown histic peat to a depth of greater than 18 inches. Small areas of the site consist of very dark gray silty loam mineral soils, or very dark mucks and loams (Parametrix 2000b). Upland soils are very dark grayish brown silty loams.

#### **Hydrology**

Hydrology within the wetland is maintained by a high groundwater table, occasional flooding from Des Moines Creek, and precipitation. Wetland hydrology in the western portion of the golf course is supported by groundwater and some overbank flow from Des Moines Creek. Wetland hydrology in the eastern portion of the wetland is primarily maintained by shallow groundwater and

precipitation that perches above a relatively impermeable layer of clay. Groundwater seeps are also found along the northern arm and in the southwest portion of the wetland. Soils in these wetland areas are typically saturated to the surface during the fall, winter, and spring months.

#### **5.3.1.7 Mitigation Design**

##### **Tyee Valley Wetland Mitigation**

The design for the wetland mitigation site is to plant a minimum of 4.5 acres of the golf course area wetland, which is currently dominated by non-native turf grass, with native shrub species (see Figure 5.3-1; Appendix C, Sheets C2 and L1). Additionally, approximately 1.6 acres of upland area adjacent to the wetland will be planted with native shrub species.

Reduced use of the site by geese following conversion of the golf course to shrub wetland will reduce inputs of fecal coliform and nutrients to the stream. In addition, planting the golf course with native shrubs, as well as establishing a forested/shrub buffer along Des Moines Creek, will increase nutrient cycling and retention in the buffer and is likely to further reduce nutrient inputs to the stream.

##### **Clearing and Site Preparation**

The design for the wetland mitigation site does not include significant changes to site topography by grading or excavation. Prior to installing plants, culverts and golf cart roads will be removed. Minor grading may take place attendant to the removal of golf course roads and existing culverts. Appropriate TESC measures will be installed prior to site preparation or clearing activities to protect the adjacent wetland and stream.

##### **Expected Hydrology**

The wetland enhancement area typically would be saturated to the surface during the fall, winter, and spring months. Soil saturation and wetland hydrology, which is maintained by high seasonal groundwater levels, will not be affected by the mitigation design. As discussed previously under Constraints, if the RDF is constructed, maximum flood levels will be slightly lower than they are now.

##### **Landscape Plan**

The planting plan consists of native shrub or small tree species that tolerate water level fluctuations, tolerate saturated soils during the fall-spring months, are typically found growing in peat soils, and are unlikely to attract significant numbers of avian wildlife (see Section 5.1.2.8; Appendix C, Sheet C2 and L1). Species tolerant of such conditions include hardhack and willows (Taylor 1993). Pacific willow, Sitka willow, and hardhack commonly occur in floodplain wetlands and are tolerant of flooding and inundation for prolonged periods. Plants will be installed in patches of varying species compositions and heights to provide the mosaic of vegetation heights that is consistent with reducing hazard wildlife attractants (USDA 2000).

The landscape plan for the area shows that the planting of conifer trees is phased (see landscape design sheets in Appendix C). It is anticipated that these conifers would be planted in a second planting phase coincident with replacement plantings that may be required to meet the year three performance standard for plant survival. At this time, the conifer species would be planted. The



trees will be positioned such that they receive some shade from adjacent plants (trees, shrubs, and groundcover). For the first growing season following this planting, soil moisture conditions will be examined closely, and the use of the temporary irrigation system may be used to reduce mortality and promote growth.

A temporary irrigation system may be installed in the drier portions of the golf course mitigation site to provide flexibility in planting schedules and to optimize growth rates during the initial plant establishment phase. Irrigation would use municipal water purchased by the Port. Irrigation will be used only during the plant establishment phase and will be removed after plant survival standards have been met. Irrigation will likely be used during the June through September time period, depending on weather conditions. Application rates are planned to be less than agronomic rates, but sufficient to reduce plant mortality and promote plant growth during the first season following planting.

### **Des Moines Creek Buffers**

The reach of the west branch of Des Moines Creek south of the Tye Valley Golf Course wetland mitigation site will be enhanced by planting native riparian trees and shrubs along both banks of the stream (Appendix C, Sheet C2). The riparian buffers will extend 100 ft from the OHWM of the stream or the edge of the riparian wetland, whichever distance is greater. Buffer plants will include black cottonwood, red alder, western redcedar, vine maple, and Nootka rose (*Rosa nutkana*).

A temporary irrigation system will be installed in the Des Moines Creek buffer to provide flexibility in planting schedules and optimize growth rates during the initial plant establishment phase. Irrigation will be provided by municipal water purchased by the Port. Irrigation will be used only during the plant establishment phase and will be removed after plant survival standards have been met. Irrigation will likely be used during the June through September time period, depending on weather conditions. Application rates are planned to be less than agronomic rates, but sufficient to reduce plant mortality and promote plant growth during the first season following planting.

#### **5.3.1.8 Performance Standard and Contingency**

Performance standards, variables to be evaluated (e.g., survival, cover), and specific contingency measures for Des Moines Creek projects are included in Table 5.3-2. The monitoring schedule is presented in Table 5.3-3.

#### **5.3.1.9 Implementation of Des Moines Creek Projects**

The Tye wetland mitigation and Des Moines Creek buffer enhancements will be coordinated with construction of the RDF. The Port will protect the mitigation sites from RDF construction impacts by placing TESC measures and orange barrier fencing at the edge of the mitigation sites. Ecology blocks will be used to further protect the mitigation sites from RDF construction impacts. Inspections will take place throughout the mitigation construction period to ensure that plans are being implemented as specified, permit conditions are met, and BMPs are installed and operating properly.

A proposed implementation plan for Tye Wetland Mitigation and Des Moines Creek buffer commencements is presented in Table 5.3-4. Plants in both the wetland mitigation and riparian

**Table 5.3-2. Final Performance Standards, Evaluation Approach, and Contingency Measures for the Tye Valley Golf Course and Des Moines Creek Buffer Mitigation Projects.**

| Design Criteria                                                                                        | Performance Standard                                                                                                                                                                                                                                                                                                                                                                                                                                                                                                                                                                                                                                                                               | Evaluation Approach                                                                                                                     | Contingency Measures                                                                                                                                                                                                                                                                                                      |
|--------------------------------------------------------------------------------------------------------|----------------------------------------------------------------------------------------------------------------------------------------------------------------------------------------------------------------------------------------------------------------------------------------------------------------------------------------------------------------------------------------------------------------------------------------------------------------------------------------------------------------------------------------------------------------------------------------------------------------------------------------------------------------------------------------------------|-----------------------------------------------------------------------------------------------------------------------------------------|---------------------------------------------------------------------------------------------------------------------------------------------------------------------------------------------------------------------------------------------------------------------------------------------------------------------------|
| 1. Shrub and small trees planted at combined density of greater than 3,375 stems per acre              | Survival of planted stock will be 100% at the end of year 1.<br>Average survival of planted stock will be at least 80% during the first 3 monitoring years.<br>Cover of native species will be at least 80% by monitoring year 15 <sup>a</sup> .<br>Cover of non-native invasive species will be no more than 10% by monitoring year 15 <sup>b</sup> .                                                                                                                                                                                                                                                                                                                                             | Vegetation sampling (plots, transects, or plotless techniques) to estimate mortality, cover, density, and presence of invasive species. | If standards are not met: <ul style="list-style-type: none"> <li>• Select species that are better adapted to existing hydrologic conditions.</li> <li>• Install additional plant material.</li> <li>• Install protective collars to reduce herbivore damage.</li> <li>• Control/reduce invasive plant species.</li> </ul> |
| 2. Plant native riparian tree and shrub plant species within the 100-ft buffer along Des Moines Creek. | Survival of planted stock will be 100% at the end of year 1.<br>Average survival of planted stock will be at least 80% during the first 3 monitoring years. Tree density will be at least 280 individuals per acre and shrub density will be at least 2,100 individuals per acre during monitoring years 3, 8, and 16.<br>In years 3, 8, and 15, the number of plant species present will not decrease more than 10% from the number installed at baseline.<br>Cover of native trees and shrubs will be at least 80% by monitoring year 15 <sup>a</sup> .<br>Cover of non-native invasive species in newly planted or enhanced areas will not exceed 10% during any monitoring year <sup>b</sup> . | Vegetation sampling (see above).                                                                                                        | See above.                                                                                                                                                                                                                                                                                                                |

<sup>a</sup> See Table 4.3-1 for interim cover targets (i.e., from year 3 to year 15).

<sup>b</sup> See Table 4.3-2 for list of invasive, non-native species to be monitored and controlled on the mitigation site.

**Table 5.3-3. Monitoring schedule for Des Moines Creek Basin mitigation projects.**

| Feature    | Activity                                                                     | Duration                                                | Data Collection Year |   |   |   |   |   |   |    |    |    |   |   |  |
|------------|------------------------------------------------------------------------------|---------------------------------------------------------|----------------------|---|---|---|---|---|---|----|----|----|---|---|--|
|            |                                                                              |                                                         | 0                    | 1 | 2 | 3 | 5 | 7 | 9 | 10 | 12 | 15 |   |   |  |
| Hydrology  | Shallow groundwater monitoring wells will be installed in the planting area. | Monthly for the first 3 years; semi-monthly thereafter. | X                    | X | X | X | X | X | X | X  | X  | X  | X | X |  |
|            |                                                                              |                                                         |                      |   |   |   |   |   |   |    |    |    |   |   |  |
| Vegetation | Measure plant survival.                                                      | Late spring or early summer.                            | X                    | X | X | X |   |   |   |    |    |    |   |   |  |
|            |                                                                              |                                                         |                      |   |   |   |   |   |   |    |    |    |   |   |  |
| Reports    | Vegetation sampling to determine cover.                                      | Late spring or early summer.                            |                      |   |   | X | X | X | X | X  | X  | X  | X | X |  |
|            |                                                                              |                                                         |                      |   |   |   |   |   |   |    |    |    |   |   |  |
| Reports    | Wetland Delineation                                                          | March                                                   |                      |   |   |   |   | X |   |    |    |    |   |   |  |
|            |                                                                              |                                                         | X                    | X | X | X | X | X | X | X  | X  | X  | X |   |  |

Table 5.3-4. Proposed implementation timeline for Tye Valley Golf Course and Des Moines Creek Buffer projects.

| Project/Activity                                    | Year 1 <sup>a</sup> |   |   |   |   |   |   |   |   |   |   |   | Year 2 |   |   |   |   |   |   |   |   |   |   |   | Year 3 |   |   |   |   |   |   |   |   |   |   |   |
|-----------------------------------------------------|---------------------|---|---|---|---|---|---|---|---|---|---|---|--------|---|---|---|---|---|---|---|---|---|---|---|--------|---|---|---|---|---|---|---|---|---|---|---|
|                                                     | J                   | F | M | A | M | J | J | A | S | O | N | D | J      | F | M | A | M | J | J | A | S | O | N | D | J      | F | M | A | M | J | J | A | S | O | N | D |
| Tye Valley Golf Course and Des Moines Creek Buffers |                     |   |   |   |   |   |   |   |   |   |   |   |        |   |   |   |   |   |   |   |   |   |   |   |        |   |   |   |   |   |   |   |   |   |   |   |
| Preconstruction meeting                             |                     |   |   |   |   |   |   |   |   |   |   |   |        |   |   |   |   |   |   |   |   |   |   |   |        |   |   |   |   |   |   |   |   |   |   |   |
| TESC, Site Preparation                              |                     |   |   |   |   |   |   |   |   |   |   |   |        |   |   |   |   |   |   |   |   |   |   |   |        |   |   |   |   |   |   |   |   |   |   |   |
| Conduct minor site grading as necessary per plans   |                     |   |   |   |   |   |   |   |   |   |   |   |        |   |   |   |   |   |   |   |   |   |   |   |        |   |   |   |   |   |   |   |   |   |   |   |
| Install plants per planting plan <sup>b</sup>       |                     |   |   |   |   |   |   |   |   |   |   |   |        |   |   |   |   |   |   |   |   |   |   |   |        |   |   |   |   |   |   |   |   |   |   |   |
| Produce record drawings                             |                     |   |   |   |   |   |   |   |   |   |   |   |        |   |   |   |   |   |   |   |   |   |   |   |        |   |   |   |   |   |   |   |   |   |   |   |
| Conduct baseline monitoring                         |                     |   |   |   |   |   |   |   |   |   |   |   |        |   |   |   |   |   |   |   |   |   |   |   |        |   |   |   |   |   |   |   |   |   |   |   |
| Begin maintenance and compliance monitoring         |                     |   |   |   |   |   |   |   |   |   |   |   |        |   |   |   |   |   |   |   |   |   |   |   |        |   |   |   |   |   |   |   |   |   |   |   |

<sup>a</sup> Year one starts with the first construction season following issuance of permits. Implementation of mitigation projects may vary from this proposed schedule depending upon coordination with other Master Plan Update projects, contract obligations, or final approval.

<sup>b</sup> Plant procurement will start 6 to 12 months prior to the anticipated planting date to ensure that plants in the specified quantities and species are available by the scheduled planting date. Planting will be phased such that coniferous species will be planted following the third year of monitoring.

buffer projects will be installed to reduce hazard wildlife attractants. A landscape architect or wetland scientist will observe plant installation to ensure that plants are installed correctly and according to the plans and specifications.

Plant material used in the mitigation will be obtained from commercial nurseries. Nurseries will be required to certify that the plant material is legally procured and from the appropriate geographic source. The appropriate geographic source for plant material used in the mitigation is defined as the area that is bounded on the north by the Fraser River Valley, B.C.; on the east by the 1,000-ft elevation of the Cascades; on the west by the 1,000-ft elevation in the Olympic or Coast ranges; and on the south by the Willamette Valley.

### **5.3.1.10 Construction Steps**

#### **General Conditions**

- On award of the contract, the contractor will provide the Port with any required pre-construction submittals, work plans, and schedules.
- A pre-construction meeting will be held with the contractor, architect/engineer, and wetland scientist to review submittals, work plans, schedules, and permit conditions.
- The contractor will be responsible for ensuring that the work is performed in compliance with all permit conditions and shall maintain a copy of permits on-site.
- Work will be coordinated to avoid re-entry and damage to areas that have previously been planted; work will be conducted so that no other work will impact completed landscape work.
- Areas where any landscape work has been completed will be off-limits to all vehicular traffic, and pedestrian traffic will be strictly limited.

#### **Pre-construction Meeting and Site Preparation**

- Establish vertical and horizontal site controls and maintain through construction to record drawings.
- Identify and flag limits of work for mitigation site.
- Identify staging areas, stockpile areas, and temporary access/haul roads.
- Implement TESC plan and install TESC measures.
- Install orange barrier fencing around the site and any vegetation to be protected.
- Install fencing and TESC measures around wetlands to be avoided in borrow areas.
- Maintain security of site through construction.
- Implement a spill control plan and identify fueling areas if needed.

#### **Clearing, Excavation, and Grading**

- Clear roads and/or culverts from the wetland mitigation site; clear and grub the riparian buffer site.

- Install hydrology monitoring wells at the wetland mitigation site.
- Prepare grading record drawings; modify planting plans as needed to match as-built grades and site conditions.

### **Irrigation and Landscaping**

- Install and test irrigation (irrigation will be designed for the wetland mitigation and buffers; however it may not be needed at the wetland mitigation site).
- Apply hydroseed to any areas of exposed soils.
- Winterize the irrigation system.
- Plant shrub wetland and forested buffer vegetation in fall/winter following grading.

### **Closeout**

- Complete site cleanup by removing temporary haul/access roads and staging areas.
- Remove construction equipment and debris.
- Hydroseed and/or install plants in temporary staging areas or access roads within the mitigation site boundaries.
- Hydroseed erosion control mix in temporary staging areas/access roads outside the mitigation boundaries.
- Install permanent fence and/or signs along mitigation site boundary.
- Install barrier fencing, rock gabions, or ecology blocks at the mitigation site boundary if necessary to protect the site from RDF construction activities.

### **Record drawings, Monitoring, and Maintenance**

- Produce grading and planting record drawings for wetland mitigation site and riparian buffers.
- Complete a baseline report, including record drawings and final monitoring plan (e.g., locations of monitoring plots, baseline conditions), for the wetland site, riparian buffers, and borrow areas.
- Begin compliance monitoring during first growing season after planting (or excavation for borrow areas) is complete; submit annual monitoring reports for 15-year monitoring period.
- Conduct maintenance (e.g., weed management, WHMP) and implement any necessary contingency measures to meet performance standards.

#### **5.3.1.11 Monitoring and Performance Standards**

Monitoring for the Des Moines Creek projects will be performed consistent with the approach, methods, and schedule outlined in Section 4 of this report. The focus of monitoring for the Des Moines Creek basin mitigation projects will be to:

- Evaluate the establishment of native wetland and riparian vegetation in the Tyee Valley Golf Course wetland and the Des Moines Creek buffers.

- Monitor groundwater and surface water levels at the Tyee Valley Golf Course wetland mitigation site.

Hydrology, vegetation, and hazard wildlife monitoring will be conducted consistent with the approach and methods described in Section 4. Groundwater monitoring will be conducted on the Tyee Valley Golf Course mitigation site to evaluate seasonal variation in groundwater levels on the site.

#### **Hydrologic Monitoring**

A series of permanent shallow groundwater monitoring wells will be installed in the enhanced wetland area at the Tyee Valley Golf Course to evaluate seasonal variation in groundwater levels on the site. Groundwater levels will be recorded monthly for the first 5 years of mitigation and every other month thereafter. The exact number and location of the wells will be determined after location of the enhancement area has been established. Wells will be installed by a licensed well driller and recorded with Ecology.

#### **Vegetation Monitoring**

The plantings at the Tyee Valley Golf Course wetland mitigation site and within the Des Moines Creek riparian buffer will be monitored over a minimum 15-year period that begins when plant installation is complete. Monitoring activities will take place in years 0, 1, 2, 3, 5, 7, 9, 10, 12, and 15 to determine species composition, survivorship, height, percent cover, density, and general health and vigor (see Table 5.3-3). Specific performance standards, parameters to measure, and contingency measures for the Des Moines Creek projects are provided in Table 5.3-2. Vegetation monitoring will follow standard vegetation sampling protocols as described in Section 4.

#### **Wildlife Monitoring**

The Port will perform wildlife monitoring in the wetland enhancement area according to requirements of the WHMP (USDA 2000). Based on the results of the wildlife monitoring, alterations to vegetation or hydrologic conditions may be necessary to comply with FAA requirements and the WHMP.

#### **5.3.1.12 Site Protection**

The Port will execute and file a restrictive covenant for the Des Moines Creek mitigation area. Copies of proposed restrictive covenants are included in Appendix G.

The boundaries of the mitigation area and buffers shall be permanently marked with stakes at least every 100 feet or with fencing. The marking shall include signage that clearly indicates that mowing and fertilizer/pesticide applications are prohibited within mitigation areas. The details of fencing and signage are provided in Appendix P.

#### **5.3.1.13 Maintenance and Contingency Plan**

Routine maintenance tasks (e.g., maintaining irrigation system, removing trash) and adaptive management/contingency measures (e.g., weed management, replacing plants) will be required during the monitoring period. Routine maintenance and contingency measures will be implemented

consistent with the approach described in Section 4. Specific contingency actions for each wetland and riparian buffer performance standard are listed in Table 5.3-2.

### **5.3.2 Des Moines Creek Basin Trust Fund for Watershed Rehabilitation**

To provide opportunities for additional restoration projects in the Des Moines Creek basin the Port will establish a trust fund to support watershed rehabilitation projects. The trust fund will focus on portions of Des Moines Creek not owned by the Port, and where the Port is unable to independently implement stream enhancement projects. The Port will make these trust funds available and defer the selection of appropriate projects to other governmental agencies or interested groups. Restoration or enhancement projects supported by the trust fund are independent of the environmental review and permit process for Master Plan Update projects (e.g., CWA 404/401, HPA), and may require local, state, or federal permits or environmental review.

#### **5.3.2.1 Goal**

The goal of this mitigation action is to enhance instream or riparian habitat for salmonids and other aquatic organisms of Des Moines Creeks on land not owned by the Port.

#### **5.3.2.2 Description**

The trust fund for watershed restoration will provide \$150,000 for restoration projects in the Des Moines Creek basin. Project information for potential projects eligible for funding by the trust fund is based on information provided in the Des Moines Creek Basin Plan (Des Moines Creek Basin Committee 1997) (Table 5.3-5). The trust fund will be established by the Port to fund watershed projects that result in direct habitat benefits to aquatic life in the streams or to remove documented water quality impacts.

Examples of projects eligible for full or partial funding include instream fisheries habitat improvements (e.g., see Figures 5.2-8 through 5.2-11), riparian buffer enhancement, removal of fish passage barriers, and removal of failed septic systems. Additional planning and engineering of selected projects would result in specific project designs, performance standards, monitoring requirements, and contingency measures. Project proponents will be responsible for obtaining federal, state, or local permits required to implement projects.

The trust fund will have a sunset clause of 5 years following issuance of Master Plan Update permits. If, after a 5-year period, projects are not designed and permits have not been sought,<sup>31</sup> the Port will use the money to implement those project(s) identified in the Des Moines Creek Basin Plan that provide water quality or aquatic habitat benefits. The project(s) to be implemented will be at the discretion of the Port, but with approval from Ecology and ACOE.

---

<sup>31</sup> The project proponents will be responsible for obtaining federal, state, and local permits required to implement the projects.



**Table 5.3-5. Summary of potential trust fund projects in the Des Moines Creek watershed (projects are as described in the Des Moines Creek Basin Plan, 1997).**

| Project                                      | Goals                                                                                                                                                                        | Description                                                                                                                                                                                                                                                                                                                    | Performance Standards                                                                     | Monitoring                                                                                                                                               | Cost Estimate <sup>a</sup> |
|----------------------------------------------|------------------------------------------------------------------------------------------------------------------------------------------------------------------------------|--------------------------------------------------------------------------------------------------------------------------------------------------------------------------------------------------------------------------------------------------------------------------------------------------------------------------------|-------------------------------------------------------------------------------------------|----------------------------------------------------------------------------------------------------------------------------------------------------------|----------------------------|
| <b>Habitat Improvements</b>                  |                                                                                                                                                                              |                                                                                                                                                                                                                                                                                                                                |                                                                                           |                                                                                                                                                          |                            |
| Ravine reach <sup>b</sup><br>(RM 1.0-1.85)   | Stabilize steep channel.<br>Provide channel geometry that responds positively to predicted flows.                                                                            | Construct 20 rock weirs throughout the reach.                                                                                                                                                                                                                                                                                  | Rock weirs remain secure/intact for 10 years.                                             | Assess function and any movement of rock weirs once a year at end of wet season.                                                                         | \$50,000                   |
| Treatment plant <sup>b</sup><br>(RM 0.4-1.0) | Provide pool habitat.<br>Increase channel complexity.<br>Reduce the risk of bank failure adjacent to sewer line access road by diverting high-velocity flows away from road. | Place 4 LWD complexes (4 to 6 logs each) on outside bends and/or channel spanning; install 15 small rock deflectors, each spanning 40% of channel (half immediately upstream of LWD complexes, half in high-velocity areas diverting flow from bank); place 5 small groups (3 to 5 rocks per group) of fish and turning rocks. | LWD complexes, rock deflectors, fish and turning rocks remain secure/intact for 10 years. | Assess functions of LWD complex, rock deflectors, fish and turning rocks; document shifting or accumulation of debris once a year at end of wet season.  | \$130,000                  |
| Park reach <sup>b</sup><br>(RM 0.0-0.4)      | Increase pool habitat.<br>Increase channel complexity.                                                                                                                       | Place 1 LWD complex (4 to 6 logs) on outside bend and/or channel spanning; install four small rock deflectors each spanning 40% of channel (half immediately upstream of LWD complexes, half in high-velocity areas diverting flow from bank); install 1 small group (3 to 5 rocks) of fish and turning rocks.                 | LWD complexes, rock deflectors, fish and turning rocks remain secure/intact for 10 years. | Assess function of LWD complexes, rock deflectors, fish and turning rocks; document shifting or accumulation of debris once a year at end of wet season. | \$50,000                   |
| Wetland reach<br>(RM 1.85-2.15)              | Maintain/enhance natural flood storage function of wetland system.                                                                                                           | Add woody debris to stream and/or buffer.                                                                                                                                                                                                                                                                                      | Installed habitat features remain secure/intact                                           | Assess functions of installed habitat features; document shifting or accumulation of debris once a year at end of wet season.                            | \$10,000                   |
| Septic systems <sup>b</sup>                  | Reduce fecal coliform levels and improve other water quality parameters in Des Moines Creek.                                                                                 | Identify houses within areas not connected to sanitary sewer.<br>Connect problem septic systems to sewer lines.                                                                                                                                                                                                                | Identified houses are connected to sewers and septic systems are decommissioned.          | As-built monitoring to verify completion.                                                                                                                | \$ 150,000                 |

<sup>a</sup> This cost estimate reflects 1997 dollars.  
<sup>b</sup> Identified as "regional high priority" in the basin plan.

### **5.3.2.3 Eligibility**

The Port or a designated administrator will consider requests for monies from the watershed trust fund to implement stream habitat enhancement projects. Requests must be made by King County, the cities of SeaTac or Des Moines, tribal governments, non-profit organizations, or combinations of such governments through interlocal agreements (ILAs). Organizations requesting funding must comply with general liability insurance requirements established by the Port.

Key criteria to be used in evaluating proposals to implement projects in Table 5.3-5, as well as other projects within the watershed, include the following:

- A demonstrated benefit to salmon or aquatic habitat without creating significant avian wildlife habitat within 10,000 ft of runways at STIA.
- Consistency with watershed management plans, or with prescriptions/recommendations identified using watershed analysis or stream assessment procedures.
- Clearly defined project goals, implementation plans, performance standards, and post-project monitoring.
- Preference for resolving underlying causes of problems rather than treating symptoms.
- Cost-effectiveness.

### **5.3.2.4 Implementation**

The Des Moines Creek Basin Committee, the King County Watershed Coordinator, Puget Sound Restoration Fund, or other responsible entity will administer the fund. The administrator will establish eligible project criteria, application forms, project cost limits, implementation and monitoring requirements, etc. The Port will review and approve the project goals, plans, performance standards, and monitoring requirements to enhance the ultimate success of the projects. The Port, or the administrator at the Port's request, will provide status reports to Ecology and ACOE.

### **5.3.2.5 Site Protection**

Site protection of enhancement projects will be coordinated with property owners and the fund administrator.

### **5.3.2.6 Monitoring and Contingency**

The fund administrator will review project design, implementation, and as-built plans to verify that the project is built as intended. Contingency actions associated with establishment or operation of the fund will be reviewed with the Port, ACOE, Ecology, and the fund administrator.

### **5.3.3 Preventing Indirect Impacts to Wetland Near Borrow Areas 1 and 3**

Mitigation to prevent indirect impacts to wetlands near Borrow Areas 1 and 3<sup>33</sup> is described in this section. Borrow Areas 1 and 3 will be excavated to provide fill material for the third runway and embankment construction (see Figure 4.1-2). Borrow area excavations have been designed to the extent practicable to avoid direct impacts to wetlands. Hydrological studies conducted by Hart Crowser (Hart Crowser 2000b,c, 2001b) indicate that the potential for indirect impacts to the hydrology of wetlands near the borrow areas is low. To further avoid and minimize potential indirect impacts, mitigation actions and monitoring is planned. Mitigation consists of drainage systems that collect surface runoff and/or groundwater seepage and direct this water to the wetlands.

Following construction, groundwater levels will be monitored in wetlands near the borrow areas to verify that wetland hydrology is present and able to maintain existing vegetation (Table 5.3-6).

Actions taken to avoid, minimize, and mitigate potential indirect impacts to wetland hydrology adjacent to the borrow areas are not included in the calculation of mitigation credit for the Master Plan Update projects. Wetlands subjected to hydrologic monitoring are:

Borrow Area 1: Wetlands B1, B4, B12, B15, 32, 48

Borrow Area 3: Wetlands B5, B6, B7, B9, B10, 29, 30.

#### **5.3.3.1 Borrow Area Site Descriptions**

The borrow areas are located south of the airfield between 24<sup>th</sup> Avenue South and 15<sup>th</sup> Avenue South, and between South 200<sup>th</sup> Street and South 216<sup>th</sup>-Street (see Figure 1.3-1). Most of these areas were formerly residential neighborhoods. Between 5 and 20 years ago, the area was acquired and cleared as part of STIA's noise abatement program.

Borrow Area 1 is located east of Des Moines Creek. The area slopes toward Des Moines Creek. Nine wetlands are located in Borrow Area 1 (Wetlands B1, B4, B11, B12, B14, B15a, B15b, 32, and 48).

Borrow Area 3 is located west of Des Moines Creek. The borrow area is bordered on the west by a relatively level plateau that slopes steeply down to a series of depressions in the southeast portion of the borrow area (Appendix H, Figure 1). The northern half and the western edge of the borrow area are high points approximately 40 ft to 120 ft higher than the low point in the southeast corner. Eight wetlands occur in Borrow Area 3 (Wetlands B5, B6, B7, B9a, B9b, B10, 29, and 30).

#### **5.3.3.2 Hydrology of Borrow Area Wetlands**

Borrow Area 1 contains wetlands whose hydrology is maintained by both groundwater and precipitation-sources. Wetlands B1, B11, B14, and 32 are depressional wetlands maintained by precipitation and surface water runoff. Wetlands B4, B12, B15, and 48 are slope wetlands maintained by groundwater seepage. Water surfacing in these slope wetlands flows downslope to Des Moines Creek. Surface water hydrology in the general vicinity of Borrow Area 1 has been

---

<sup>32</sup> The hydrology in Wetland 28, located north of Borrow Area 4, will also be monitored.

<sup>33</sup> The hydrology in Wetland 28, located north of Borrow Area 4, will also be monitored.

**Table 5.3-6. Final Performance Standards, Evaluation Approach, and Contingency Measures for Monitoring Borrow Area Wetlands.**

| <b>Design Criteria</b>                                                                                                                               | <b>Performance Standard</b>                                                                                                                                                                                                                                                                                                                                                                                                                                                                                                                                                                                                 | <b>Evaluation Approach</b>                                                                                             | <b>Contingency Measures</b>                                                                                                                                                                                          |
|------------------------------------------------------------------------------------------------------------------------------------------------------|-----------------------------------------------------------------------------------------------------------------------------------------------------------------------------------------------------------------------------------------------------------------------------------------------------------------------------------------------------------------------------------------------------------------------------------------------------------------------------------------------------------------------------------------------------------------------------------------------------------------------------|------------------------------------------------------------------------------------------------------------------------|----------------------------------------------------------------------------------------------------------------------------------------------------------------------------------------------------------------------|
| Maintain wetland hydrology by redirecting surface water runoff to the wetlands near Borrow Area 1.                                                   | Soils in wetlands near Borrow Area 1 (Wetlands 48 and B15) will be saturated to the surface from December to April in years of normal <sup>a</sup> rainfall.                                                                                                                                                                                                                                                                                                                                                                                                                                                                | Shallow groundwater monitoring wells.                                                                                  | Minor grading to direct surface water runoff to wetlands                                                                                                                                                             |
| Maintain wetland hydrology by directing groundwater seepage and surface water runoff via an interceptor swale to wetlands in and near Borrow Area 3. | Wetland 30 will have shallow standing water up to 24 inches deep during the breeding season for resident amphibians (i.e., December through April).<br>Wetland 29 will have soils saturated to the surface from December through April in years of normal <sup>a</sup> rainfall.                                                                                                                                                                                                                                                                                                                                            | Shallow groundwater monitoring wells and measurement of surface water depths.<br>Shallow groundwater monitoring wells. | Adjust length and discharge points of interceptor swale system<br>Adjust length and discharge points of interceptor swale system                                                                                     |
| Wetland vegetation will remain in wetlands adjacent to and downslope of borrow areas 1, 3, and 4.                                                    | Wetland indicator status (WIS) of the dominant non-invasive plant species will not differ from pre-project conditions during or at the end of the monitoring period. Each vegetation strata (trees, shrubs, and emergents) shall be assessed separately, and have separate conclusions. Statistically valid sampling procedures will be employed to monitor these potential changes, in all areas where there is a potential to change the post construction hydrology (downslope of the embankment and the borrow sites). WIS status of the vegetation will be calculated as in the 1987 USACE wetland delineation manual. | Vegetation sampling to determine plant cover, dominance, and presence of invasive species.                             | For Borrow are 3, alter distribution of water from the interceptor swale<br>For other wetlands, review grading and drainage patterns of borrow sites.<br>Regrade to provide additional water to wetlands of concern. |

<sup>a</sup> Normal rainfall will be based on the definition for 'most years' given in the USACE 1987 Manual (i.e. annual precipitation in a normal year must be the same as or greater than precipitation in 5 years out of 10) or the average precipitation for a time period plus or minus 1 standard deviation of the mean.

altered by the system of storm drains, culverts, and drainage ditches constructed when the area was developed. Since clearing the area for the noise abatement program, these surface drainage features have been abandoned and have deteriorated to such an extent that past drainage patterns are changing.

Wetland 29 occurs on the hillside at the west edge of the Borrow Area 3. Hydrology in this wetland is supported by groundwater seeps discharging on the face of the slope from a zone of perched groundwater that extends to the north and west (Hart Crowser 2000b, c; 2001b; Appendix H). Wetlands 30, B7, B6, and B5 occupy a series of depressions in the lower southeastern corner of Borrow Area 3. These wetlands may be supported by some shallow subsurface flow or interflow moving downslope from Wetland 29 (Hart Crowser 2000b,c), and by precipitation. Since these wetlands occur below the main perched groundwater layer on this site, the perched groundwater is available to continue to support wetland hydrology. Water is held in these wetlands by the relatively impermeable soils lining the depressions, promoting shallow perched conditions (Hart Crowser 2000c).

### **5.3.3.3 Actions to Avoid, Minimize, and Mitigate Indirect Impacts**

#### **Borrow Area 1**

The excavation in Borrow Area 1 has been designed to avoid direct impacts to Wetlands B1, B4, B15a, B15b, 32, and 48 (see Figure 3.1-2). Indirect impacts to wetlands downslope of the borrow area will be minimized by not excavating portions of the borrow area that lie within the watershed of these wetlands. Hydrology in these wetlands appears to be maintained by seasonal groundwater that perches on the till soils following periods of high rainfall. The existing SDS on 20<sup>th</sup> Avenue South collects surface runoff and directs it away from these wetlands. This SDS forms the eastern edge of the watershed for Wetlands 48, B15a, and B15b. Since excavation will not occur west of 20<sup>th</sup> Avenue South, the watersheds of these wetlands will not be altered and indirect hydrologic impacts are not expected to occur.

Wetland hydrology will be monitored in Wetlands 48, B15a, and B15b to verify that wetland hydrology continues to be present in these wetlands (see Table 5.3-6).

#### **Borrow Area 3**

A drainage swale will be installed during the excavation of Borrow Area 3 to convey groundwater to Wetland 29 and replace the potential loss of seepage from the perched groundwater zone (Appendix H, Figures 3, 7, and 8). This swale will collect groundwater seepage from the excavated slope face on the north and west sides of Borrow Area 3. Flow in this swale will be collected and conveyed south in a swale that drains into Wetland 29 (Appendix H, Figure 3).

Since the swale will extend for the full length of the seepage face in the borrow area, it may convey flows in excess of those needed to support hydrology in Wetland 29 and downslope wetlands (i.e., Wetland 30, which receives overland flow and shallow interflow from Wetland 29). Two measures will be used to manage excess flows and to optimize the distribution of water to Wetland 29. A flow control structure (weir and diversion structure) will be constructed in the swale just before it flows into Wetland 29 (Appendix H, Figure 9). This control structure will allow a controlled flow

rate to be directed into Wetland 29 and enable diversion of other flows away from the wetland and into the base of Borrow Area 3. Diverted flows will either be allowed to infiltrate at the base of Borrow Area 3 or be diverted to stormwater management facilities that will be constructed to manage runoff from the remainder of the borrow area. The length of the collector swale can also be modified (consistent with the adaptive management approach) based on post-construction monitoring to control the amount of seepage and runoff that is collected in the swale and diverted to Wetland 29.

Studies of borrow area hydrology indicate that impacts to the hydrology of the remaining wetlands in Borrow Area 3 (B5, B6, B7, B9a, B9b, B10, and 30) are not anticipated (Hart Crowser 2000a,b,c). Wetlands in Borrow Area 3 will be monitored before, during, and after excavation to verify that wetland hydrology will remain. If Wetlands 29 and 30 do not meet hydrologic performance standards developed for them (see Table 5.3-6), then contingency measures will be implemented. The collector swale system also can be used to divert additional water to Wetlands 29 if necessary.

#### 5.3.3.4 Hydrology Monitoring

Permanent shallow groundwater monitoring wells will also be installed in wetlands near borrow areas to verify there are no indirect hydrologic impacts. Groundwater levels will be recorded monthly for the first 5 years, and then every other month thereafter. In addition, a staff gage will be installed in Wetland 30 to allow monitoring of the extent and duration of surface water ponding that provides habitat for amphibians. Water levels will be monitored according to conditions of the *401 Water Quality Certification*, September 21, 2001 (Ecology 2001).

Evaluation of hydrology in wetlands near Borrow Areas 1 and 3 will be based on shallow groundwater data collected during pre- and post-construction periods. Borrow Area Wetlands 48, B15, 32, B12, B4, and B1 will be evaluated. All wetlands adjacent to Borrow Area 3 will be evaluated.

The Port will collect bi-monthly hydrologic monitoring data during the wet season, November through May, for at least 3 years after completion. Maps of sample locations and vegetation in the surrounding areas, observation of stressed vegetation, any adaptive management implemented in the surrounding areas, comparison to baseline data, and conclusions will be documented and submitted to Ecology on a monthly basis during that period. At the end of each water year the Port will complete and submit to Ecology a trends analysis with proposed contingency measures if needed. A schedule for completion of the proposed contingency measures will also be provided.

In Borrow Area 3, special emphasis shall be given to the area near where the drainage swale discharges into Wetland 29, to provide an early indication of hydrologic changes that may affect vegetation in the wetland. In Wetland 30, the evaluation approach will include measurements of surface water depths taken at least measured monthly during the period from December through April, and the monitoring results compared to pre-construction data.

### **5.3.3.5 Wetland Delineation**

Wetlands in the mitigation area will be delineated in years 5, 10, and 15. A licensed survey crew shall map the wetland boundary, and maps will be provided to Ecology by December 31<sup>st</sup> of the year the delineation was completed. If wetland boundaries have decreased, additional mitigation may be required.

### **5.3.3.6 Protection and Maintenance**

The drainage swale, downslope wetlands, and the unexcavated southern portion of Borrow Area 3 study area will be placed in restrictive covenants (see Appendix G). Periodic inspection and maintenance of the channel may be required to assure that it continues to perform as designed.

The wetland protection swale will be inspected and maintained at a minimum frequency of 2 times per year. Swale maintenance will include adjustment of flow control weir boards to provide appropriate flows to Wetland 29 and removal of vegetation or fill in the swale which may interfere with the seepage collection and diversion functions of the swale. A weir gage will be installed and calibrated. The gage will be marked with water depth and flow rates as that weir discharges can be determined immediately.

The boundaries of the mitigation area and buffers shall be permanently marked with stakes at least every 100 feet or with fencing. The marking shall include signage that clearly indicates that mowing and fertilizer/pesticide applications are prohibited within mitigation areas. The details of fencing and signage are provided in Appendix P.





## 6. HYDROLOGIC IMPACTS AND MITIGATION

This section describes actions incorporated into the STIA Master Plan Update improvements to mitigate potential impacts to water quantity and quality in the Miller, Walker, and Des Moines Creek basins. Existing water quantity and quality conditions, future changes in land use that affect surface water runoff, and projected future conditions under the Master Plan Update improvements and the proposed mitigation actions are summarized in this section.

Section 6.1 describes the proposed stormwater management program to control stormwater peak flow rates and flow durations from both newly developed project areas and existing airport areas. Proposed facilities, including approximately 344.1 acre-ft of new stormwater detention storage at 14 locations, will mitigate the impacts of new impervious surfaces on flows in Miller, Walker, and Des Moines Creeks. Section 6.2 summarizes actions to mitigate water quality impacts, including water quality treatment using BMPs and source controls, erosion and sediment control, and elimination of existing activities that degrade water quality. The flow control and water quality mitigation activities summarized below are based on stormwater information provided in the *Comprehensive Stormwater Management Plan* (Parametrix 2000a, 2001a).

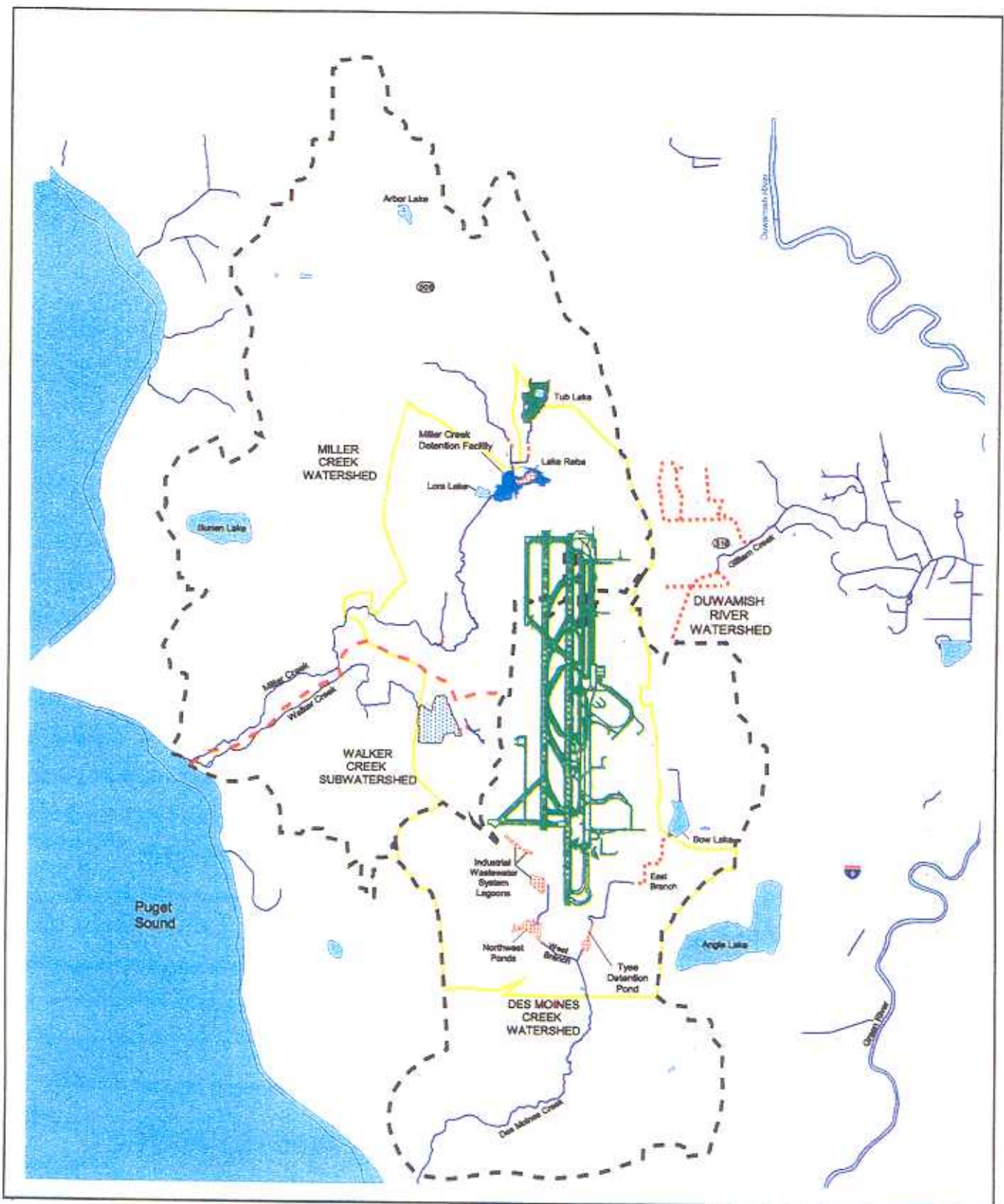
### 6.1 WATER QUANTITY

The Master Plan Update improvements could increase peak flows and reduce base flows in Miller, Walker, and Des Moines Creeks (Figure 6.1-1), thereby impacting aquatic habitat in these streams. The addition of new impervious area associated with the Master Plan Update improvements affecting the hydrology of these streams is discussed in the following sections, along with associated mitigation measures that compensate for these actions.

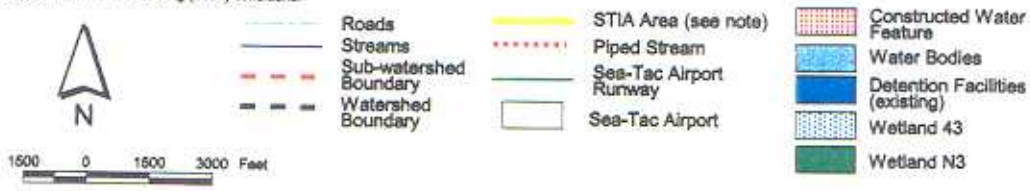
#### 6.1.1 Stormflow Impacts

The activities associated with the Master Plan Update improvements will include adding new impervious surfaces (new runways, taxiways, parking, and roadways) and filling wetlands. This action, if unmitigated, could change the hydrologic flow regime of Miller, Walker, and Des Moines Creeks, including increased peak flow magnitude and frequency, and increased elevated flow duration. The potential effects of high-flow impacts in the stream are increased erosion and sedimentation, habitat damage from scouring flows, and impaired habitat use during high-flow periods.

Proposed peak flow mitigation reduces peak flows from existing levels in both streams, which will reduce bank and channel erosion as well as sedimentation in downstream reaches, including estuaries. Additional detail on hydrology and stormwater management are provided in the (Parametrix 2000a, 2001a). The plan includes modeling conducted to estimate the impacts of the project on the Miller, Walker, and Des Moines Creek systems. The HSPF model was used for this purpose.



metrix, Inc. Sea-Tac Airport / 866-2812-001 File: K:\GIS\2512A\review\seatac\_4\_jimkelly.apr  
 se: Roads based on King County data. Water bodies derived from USGS hydrography data.  
 tion boundaries are approximates. Estimated wetland boundaries are based on field reconnaissance by Parametrix, Inc.  
 © STIA subbasins assume existing (1994) conditions.



1500 0 1500 3000 Feet

**Figure 6.1-1  
 Miller, Walker,  
 and Des Moines  
 Creek Watershed**

AR 049286

### **6.1.1.1 Wetland Fill**

The potential impacts to the hydrology of Miller, Des Moines, and Walker Creeks from filling 18.37 acres of wetlands are the loss of stormwater storage, groundwater recharge, and groundwater discharge. These functions are discussed below, and all wetland hydrologic functions are accounted for in the HSPF model, which assesses runoff impacts by various input parameters and calibration.

#### **Stormwater Storage**

Most wetlands filled by the project provide limited stormwater storage because they do not occur in closed basins or basins with restricted outlets that would allow water to pond during storms, and release water slowly following storms. Most wetlands occur on moderate to gentle slopes and are free-draining (seldom, if ever, ponding water).

In contrast, flood storage functions are provided by the riparian wetlands located in the 100-year floodplain of Miller Creek. Approximately 8,455 cy of flood storage would be filled at Vacca Farm, and approximately 9,589 cy of new floodplain will be excavated adjacent to the stream. All flood storage, including that provided by wetlands, is accounted for in the calibration of the HSPF model; design of stormwater detention facilities using this model will assure that flow mitigation is provided to account for impacted wetlands.

#### **Groundwater Discharge**

Several wetlands are sites of groundwater discharge, and thereby potentially provide base flow support to streams during all or portions of the year. Where fill occurs in these wetlands, the project has been designed to allow these discharge functions to continue. For example, the third runway embankment is designed with an internal drainage system that will collect water that currently infiltrates on the airfield and discharges in wetlands near 12<sup>th</sup> Avenue South. The drainage system will also collect water that infiltrates into the new embankment, and discharge it to wetlands and Miller Creek (see Section 5.2.3). Drainage systems associated with the retaining wall, which will be constructed to reduce wetland impacts, will also convey groundwater downslope to wetlands and the stream. Groundwater discharge effects on base flow are accounted for in the calibration of the HSPF model.

#### **Groundwater Recharge**

Most wetlands affected by fill are unlikely to have significant groundwater recharge functions because they occur on till soils, where layers of till restrict groundwater recharge. These low permeabilities result in poor drainage conditions, which in combination with topography and surface drainage features, promote the development of wetlands. Other wetlands occur in areas of known groundwater discharge (i.e., wetlands formed by local groundwater discharges) and thus cannot recharge groundwater. However, the HSPF model is based on the premise that all wetlands infiltrate; thus the model conservatively accounts for potential impacts to groundwater recharge as a result of filling these wetlands. Overall, development of impervious surfaces from Master Plan Update improvements could reduce groundwater recharge and eventual groundwater discharge to streams. These functions are accounted for in the HSPF model, and mitigation for these effects is included in the activities discussed in Sections 5 and 7 of this document, as well as in the *Comprehensive Stormwater Management Plan* (Parametrix 2000a, 2001a).

### 6.1.1.2 Indirect Hydrologic Impacts/ Impact Avoidance

Where feasible and practicable, direct and indirect impacts to the hydrologic functions of wetlands (base flow, groundwater discharge, and stormwater storage) have been avoided (Parametrix 2000a, 2001a,b). For example, within the three borrow areas, direct and indirect impacts to hydrologic functions of wetlands were avoided or minimized by protecting several wetlands and their upslope watersheds from excavation. Wetlands located downslope of excavation or fill areas will continue to receive ground and surface water from upslope areas because BMPs for water quality, site grading, and other surface water management features will allow clean water to continue to discharge to them. Additionally, rainwater will continue to infiltrate on the borrow sites because no impervious surface will be added, and this water will be available to recharge downslope wetlands and Des Moines Creek.

### 6.1.1.3 Impervious Area

In the Miller Creek Basin, Master Plan Update improvement projects will result in a net increase of 105.6 acres<sup>33</sup> of impervious surface area (Table 6.1-1), increasing the overall impervious area in the basin by about 1 percent above the existing baseline condition (about 23 percent of impervious surface; Parametrix 2000a, 2001a). In the Walker Creek basin, Master Plan Update improvements will result in a net increase of 6.2 acres of impervious surface. In the Des Moines Creek basin, Master Plan Update improvements will result in a net increase of 128.2 acres of impervious surface, increasing the overall impervious area in the basin by about 4 percent above the existing base condition (approximately 32 percent impervious surface; Parametrix 2000a, 2001a).

The new impervious surfaces could increase stormwater runoff rates (FAA 1996) and volumes. Unless mitigated, changes in runoff would be expected to increase flooding and erosion, and degrade instream habitat and water quality in Miller, Walker, and Des Moines Creeks downstream of stormwater inputs from the improved areas. As discussed below, the Port's *Comprehensive Stormwater Management Plan* includes mitigation to manage runoff from newly developed Master Plan Update improvement areas. In addition, existing hydrologic impacts from existing impervious surfaces will be mitigated.

### 6.1.1.4 Flow Control for New Master Plan Update Improvements and Retrofitting for Existing Airport Areas: Level 2

To protect instream and estuarine habitat, the Port has committed to achieving streamflows that maintain or reduce existing peak flow magnitude and duration in Miller and Des Moines Creeks. The Level 2 flow control standard, as defined by the King County Manual (King County DNR 1998), requires matching or improving post-developed flow duration to pre-developed flow durations<sup>34</sup> for all flow magnitudes between 50 percent of the 2-year event and the full 50-year event.

---

<sup>33</sup> The net change in impervious area includes removal of approximately 50 acres of impervious surfaces (streets, driveways, and rooftops) that will result when existing houses and streets are removed in the acquisition area. Demolition in these areas is ongoing and expected to be completed by 2002.

<sup>34</sup> Flow duration control refers to limiting the duration of geomorphically significant flows (i.e., those flows that initiate bedload movement) to baseline (pre-Master Plan Update) conditions.

**Table 6.1-1. Summary of Miller, Walker, and Des Moines Creek drainage areas at STIA and change in impervious area between 1994 baseline and 2006 future conditions (acres).**

| Stormwater<br>Outfall <sup>a</sup> | 1994 Baseline |                         |               | 2006 Future Condition |                         |               | Increase in<br>Impervious Area |
|------------------------------------|---------------|-------------------------|---------------|-----------------------|-------------------------|---------------|--------------------------------|
|                                    | Pervious      | Impervious <sup>b</sup> | Total         | Pervious              | Impervious <sup>b</sup> | Total         |                                |
| <b>Miller Creek</b>                |               |                         |               |                       |                         |               |                                |
| SDN1                               | 6.2           | 9.9                     | 16.1          | 3.5                   | 12.7                    | 16.1          | 2.8                            |
| SDN1LWR                            | 5.0           | 0.4                     | 5.4           | 4.9                   | 0.6                     | 5.4           | 0.2                            |
| SDN1OFF                            | 25.8          | 10.5                    | 36.3          | 28.3                  | 8.0                     | 36.3          | -2.5                           |
| SDN2X                              | 7.2           | 0.3                     | 7.5           | 5.3                   | 2.2                     | 7.5           | 1.9                            |
| SDN3                               | 33.4          | 14.5                    | 47.9          | 23.6                  | 24.3                    | 47.9          | 9.8                            |
| SDN3A                              | 28.6          | 1.9                     | 30.5          | 22.2                  | 8.2                     | 30.5          | 6.3                            |
| SDN3X                              | 25.4          | 0.0                     | 25.4          | 25.4                  | 0.0                     | 25.4          | 0.0                            |
| SDN4                               | 27.7          | 2.6                     | 30.3          | 18.1                  | 12.3                    | 30.3          | 9.7                            |
| SDN4X                              | 14.1          | 1.1                     | 15.2          | 11.0                  | 4.2                     | 15.2          | 3.1                            |
| SDW1A                              | 52.0          | 0.9                     | 52.8          | 37.4                  | 15.4                    | 52.8          | 14.5                           |
| SDW1B                              | 92.5          | 4.3                     | 96.9          | 69.9                  | 27.0                    | 96.9          | 22.7                           |
| NEPL                               | 41.4          | 0.9                     | 42.3          | 10.0                  | 32.3                    | 42.3          | 31.4                           |
| CARGO                              | 7.0           | 1.1                     | 8.1           | 0.0                   | 8.1                     | 8.1           | 7.0                            |
| Other STIA <sup>b</sup>            | 246.5         | 15.1                    | 261.8         | 247.8                 | 13.8                    | 261.8         | -1.3                           |
| <b>Total</b>                       |               |                         |               |                       |                         |               | <b>105.6</b>                   |
| <b>Walker Creek</b>                |               |                         |               |                       |                         |               |                                |
| SDW2                               | 41.3          | 3.3                     | 44.6          | 35.1                  | 9.5                     | 44.6          | 6.2                            |
| M8                                 | 22.2          | 6.6                     | 28.8          | 22.2                  | 6.6                     | 28.8          | 0.0                            |
| M9                                 | 76.1          | 22.5                    | 98.6          | 76.1                  | 22.5                    | 98.6          | 0.0                            |
| <b>Total</b>                       |               |                         |               |                       |                         |               | <b>6.2</b>                     |
| <b>Des Moines Creek</b>            |               |                         |               |                       |                         |               |                                |
| SDE4                               | 50.7          | 115.5                   | 166.2         | 40.1                  | 126.1                   | 166.2         | 10.6                           |
| SDS1                               | 0.9           | 16.8                    | 17.7          | 1.4                   | 16.3                    | 17.7          | -0.5                           |
| SDS2                               | 7.7           | 1.5                     | 9.2           | 8.1                   | 1.0                     | 9.2           | -0.5                           |
| SDS3                               | 165.5         | 178.0                   | 343.5         | 144.3                 | 199.2                   | 343.5         | 21.2                           |
| SDS3A                              | 62.7          | 7.1                     | 69.8          | 34.6                  | 35.1                    | 69.8          | 28.0                           |
| SDS4                               | 45.4          | 19.2                    | 64.6          | 32.1                  | 32.5                    | 64.6          | 13.3                           |
| SDS5                               | 32.1          | 0.4                     | 32.5          | 28.3                  | 4.2                     | 32.5          | 3.8                            |
| SDS6                               | 12.5          | 4.3                     | 16.7          | 13.5                  | 3.2                     | 16.7          | -1.1                           |
| SDS7                               | 83.2          | 8.0                     | 91.3          | 55.1                  | 36.2                    | 91.3          | 28.2                           |
| SASA                               | 25.3          | 8.9                     | 34.3          | 0.0                   | 34.3                    | 34.3          | 25.4                           |
| Other STIA <sup>c</sup>            | 136.1         | 57.7                    | 194.4         | 136.0                 | 57.5                    | 193.5         | -0.2                           |
| <b>Total</b>                       |               |                         |               |                       |                         |               | <b>128.2</b>                   |
| <b>IWS</b>                         |               |                         |               |                       |                         |               |                                |
| NCPS                               | 6.9           | 28.8                    | 35.7          | 4.8                   | 30.9                    | 35.7          | 2.1                            |
| NSMPS                              | 6.6           | 0.0                     | 6.6           | 4.7                   | 2.0                     | 6.6           | 2.0                            |
| NSPS                               | 0.3           | 13.5                    | 13.8          | 0.3                   | 13.4                    | 13.8          | -0.1                           |
| Primary                            | 24.9          | 277.6                   | 302.6         | 13.5                  | 289.1                   | 302.6         | 11.5                           |
| SASA                               | 51.8          | 6.5                     | 58.3          | 0.1                   | 58.3                    | 58.4          | 51.8                           |
| <b>Total</b>                       |               |                         |               |                       |                         |               | <b>67.3</b>                    |
| <b>TOTAL</b>                       | <b>1465.0</b> | <b>839.7</b>            | <b>2305.8</b> | <b>1157.7</b>         | <b>1147.0</b>           | <b>2304.9</b> | <b>307.3</b>                   |

Note: Rows may not total exactly as shown due to rounding. Source: Geographic Information System (GIS) coverage.

<sup>a</sup> Locations of stormwater outfalls are mapped in the *Comprehensive Stormwater Management Plan* (Parametrix 2000a, 2001a).

<sup>b</sup> Impervious area includes impervious area, lakes, and detention ponds.

<sup>c</sup> This includes outfalls MC6 and MC7.

The Level 2 analysis is more protective than stormwater control standards that have been used in the past. Previous controls allowed using an “event model,” which is a hydrologic model that compares pre-development runoff with post-project runoff using a hypothetical design storm; only peak flows were evaluated for compliance with standards. The Level 2 analysis used in the *Comprehensive Stormwater Management Plan* requires that a “continuous simulation” model (HSPF) be used and actual precipitation runoff is modeled. Pre-development runoff is compared with post-project flows over a range of probable flows. Level 2 flow analysis evaluates flow protection and mitigation measures over a wide range of erosive stormflows, whereas Level 1 analysis and event models are only protective of certain peak flows or flooding events. Level 2 is more protective of stream morphology, habitat (such as stream substrate), and hydrologic flow patterns.

The pre-developed condition for the Level 2 standard will be based on a *target flow regime*. The target flow regime used assumes that the existing watershed land cover is 10 percent impervious (or less if the existing impervious area is less than 10 percent impervious), 15 percent pervious “grass,” and 75 percent pervious “forest.”<sup>37</sup> Basing target flow on theoretical basin development of 10 percent (Miller Creek and Des Moines Creek existing impervious areas are 23 percent and 32 percent, respectively) is expected to reduce existing peak flows and be beneficial in maintaining stable stream channels (Parametrix 2000a, 2001a).

In the Des Moines Creek basin, the target flow regime was determined in a study by the University of Washington (King County CIP Design Team 1999). The flow regime determined for Des Moines Creek coincides with a target flow regime that would occur with an effective watershed impervious area of 10 percent. In studies of several Puget Sound streams, Booth and Jackson (1997) identified an approximately 10 percent impervious area threshold above which stream channel instability and habitat degradation occur.

The net result of flow retrofitting in the watersheds will be to reduce existing stormwater peak flows downstream of STIA in Miller and Des Moines Creeks *before flow impacts and controls for the Master Plan Update improvements are considered*. That is, even though the Miller Creek and Des Moines Creek watersheds have an existing impervious area of about 23 and 32 percent, respectively (Parametrix 2000a, 2001a), the flows from areas draining the airport will be reduced to a level corresponding to approximately 10 percent impervious area.<sup>38</sup>

---

<sup>36</sup> Flow duration control refers to limiting the duration of geomorphically significant flows (i.e., those flows that initiate bedload movement) to baseline (pre-Master Plan Update) conditions.

<sup>37</sup> In areas where existing impervious area is less than 10 percent, the impervious area is not changed and the difference between actual percent impervious and 10 percent is assumed to be grass.

<sup>38</sup> The HSPF model was calibrated with recorded flow data and actual basin land use prior to simulation of adding Level 2 flow control retrofits. The calibration accounts for flows attributable to each type of land use, based on existing conditions. Flows for other land use and hydrologic control conditions (such as 10 percent impervious surfaces and the Level 2 flow control retrofit) were then simulated using the HSPF model.

### **6.1.1.5 Estimated Detention Storage Requirements**

Proposed stormwater detention facilities for the Master Plan Update improvements were designed based on the drainage area served by each facility, the detention standard, the detention storage volume required to meet the flow control standards, and potential for waterfowl attraction. Approximately 344 acre-ft of new stormwater detention storage will be needed to mitigate the impacts of increased stormwater runoff (Table 6.1-2) associated with Master Plan Update improvements. The locations of new facilities are shown in Figure 6.1-2.

For sub-watersheds draining to the Des Moines Creek RDF or the Miller Creek detention facility, additional future analysis by the Port or the Basin Committees may show that the target flow and Level 2 standards can be met in the regional facilities. Stormwater detention facilities shown by the Port may be modified, with approval by Ecology, to reflect available detention in the regional facilities. In either case, the objective to meet the target flow using the Level 2 standard for both streams will be achieved.

#### **Pond and Vault Construction and Operation**

The feasibility of proposed stormwater ponds and vaults is demonstrated by the recent construction of similar facilities at STIA, including the North Employees' Parking Lot Vault (1997) and the Interconnecting Taxiways Vault (1998). Only the SASA detention pond will displace wetlands, a 0.06-acre shrub wetland. All other on-site detention facilities will be constructed in non-wetland areas. The primary discharge from the detention facilities will be surface discharge (not infiltration). However, infiltration is proposed at two stormwater facilities, SDW1A and SDW1B, to enhance base flows and reduce detention facility size. Detention facilities will consist of dry ponds with live storage<sup>39</sup> and will not include wet ponds with dead storage.<sup>40</sup>

#### **Net Result of Hydrologic Mitigation**

The net result of flow controls for the Master Plan Update improvements will be to maintain or reduce peak flows in Miller, Walker, and Des Moines Creeks to a stable flow regime downstream of STIA discharges (Tables 6.1-3 and 6.1-4). Stormwater facilities will retrofit existing flows to the target watershed flow regime pre-development conditions before new development is considered. The net effect of flow controls for Miller, Walker, and Des Moines Creeks (Figures 6.1-3, 6.1-4, 6.1-5, and 6.1-6) will be to maintain stormflows below existing conditions or the target watershed flow regimes following Master Plan construction and peak flow mitigation, whichever is less. The target flow regime will reduce flows in the stream channels, thereby reducing erosion and improving channel stability.

---

<sup>39</sup> Live storage is that volume of stormwater stored in a detention facility that drains following the storm. Live storage is used for hydrologic benefit to reduce flow peaks and durations.

<sup>40</sup> Stormwater for supplemental lowstream flow may be stored as dead storage in vaults.

**Table 6.1-2. Summary of required detention facility volumes.**

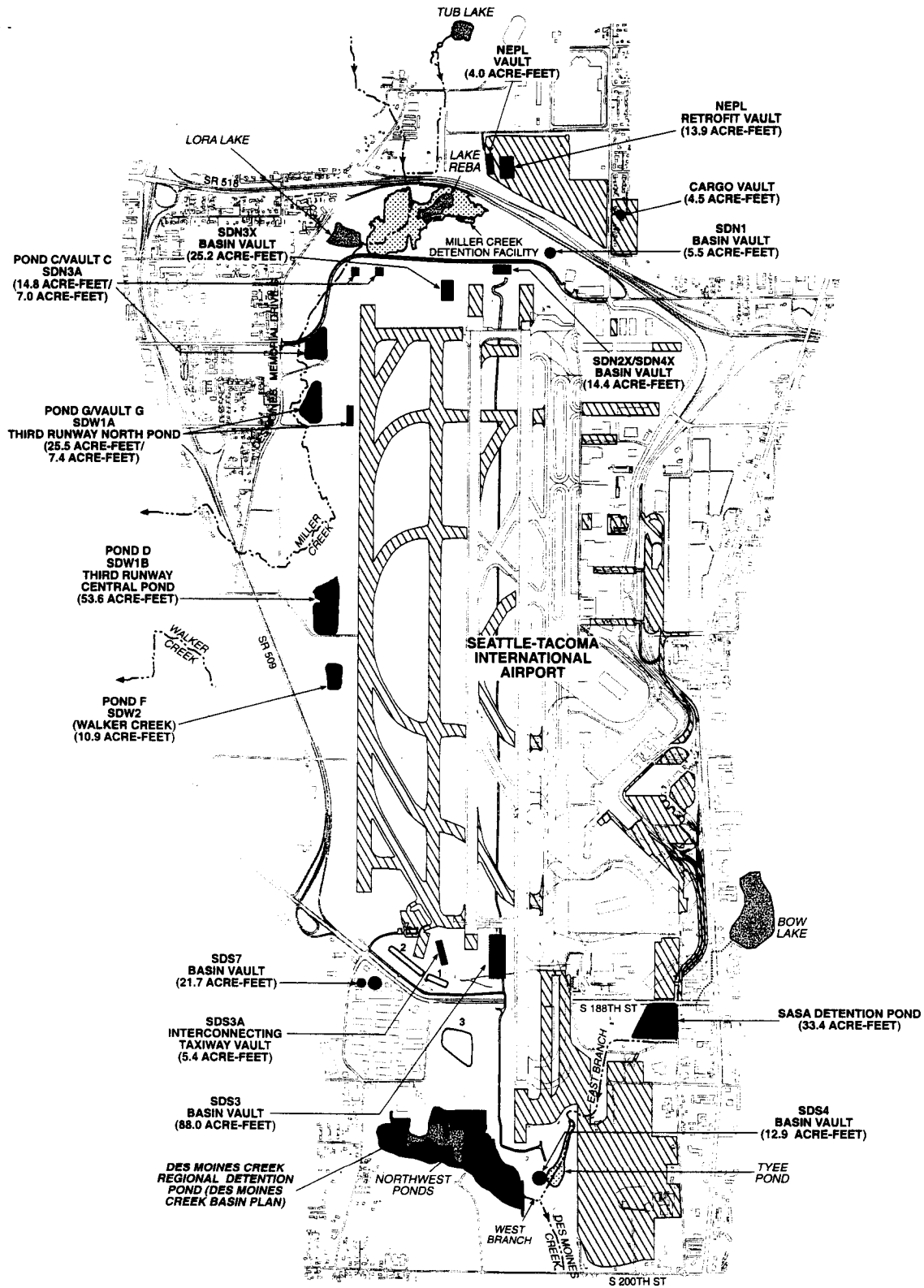
| <b>Watershed</b>              | <b>Hydrologic Evaluation Point</b> | <b>Volume Required (acre-ft)</b> | <b>Type of Facility<sup>a</sup></b> | <b>Comments</b>                        |                   |
|-------------------------------|------------------------------------|----------------------------------|-------------------------------------|----------------------------------------|-------------------|
| <b>Miller Creek</b>           | NEPL                               | 13.9 <sup>b</sup>                | Vault                               | <b>In addition to existing 4 ac-ft</b> |                   |
|                               | CARGO                              | 4.5                              | Vault                               |                                        |                   |
|                               | SDN2x + SDN4x                      | 44.4                             | Vault                               |                                        |                   |
|                               | SDN3/3x                            | 25.2                             | Vault                               |                                        |                   |
|                               | SDN1                               | 5.5                              | Vault                               |                                        |                   |
|                               | SDN3A                              | Pond: 14.8 /<br>Vault: 7.0       | Pond/Vault                          |                                        |                   |
|                               | SDW1A                              | Pond: 25.5 /<br>Vault: 7.4       | Pond/Vault                          |                                        | Infiltration used |
|                               | SDW1B                              | 53.6                             | Pond                                |                                        | Infiltration used |
| <b>Total Miller Creek</b>     |                                    | <b>171.8</b>                     |                                     |                                        |                   |
| <b>Total Walker Creek</b>     | <b>SDW2</b>                        | <b>10.9</b>                      | <b>Pond</b>                         |                                        |                   |
| <b>Des Moines Creek</b>       | <b>SASA Detention Facility</b>     | <b>33.4<sup>c</sup></b>          | <b>Pond</b>                         |                                        |                   |
|                               | Interconnecting taxiway (SDS3A)    | 5.5                              | Vault                               |                                        |                   |
|                               | Third Runway South (SDS7 and 6)    | 21.6                             | Vault                               |                                        |                   |
|                               | SDS3                               | 88.0                             | Vault                               |                                        |                   |
|                               | SDS4                               | 12.9                             | Vault                               |                                        |                   |
| <b>Total Des Moines Creek</b> |                                    | <b>161.4</b>                     |                                     |                                        |                   |

<sup>a</sup> Types of facilities are: Vault – an enclosure with multiple orifice outlets on a vertical riser with overflow spillway; or  
Pond – open earth construction with netting or other means to provide wildlife deterrent.

<sup>b</sup> This is the volume needed to retrofit the existing facility.

<sup>c</sup> This is the volume required to retrofit the STIA area only.





Natural Resources Mitigation Plan/556-2912-001/01(03) 11/01 (K)

AR 049293

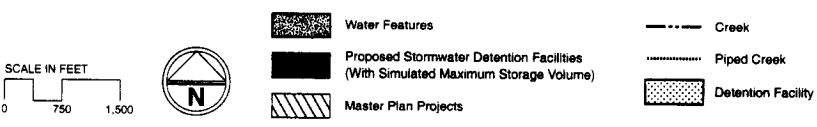


Figure 6.1-2  
Proposed Detention Facilities  
for Master Plan Projects

Table 6.1-3. Summary of flood peak flow frequency results for Miller/Walker Creek subbasins (all values are cfs).

| Return Period Peak | NEPL        |         | CARGO       |         | SDW2        |         | SDW1B       |         | SDN3A (Vacca) |         |
|--------------------|-------------|---------|-------------|---------|-------------|---------|-------------|---------|---------------|---------|
|                    | Pre-Project | Project | Pre-Project | Project | Pre-Project | Project | Pre-Project | Project | Pre-Project   | Project |
| 1/2 Q <sub>2</sub> | 0.61        | 0.22    | 0.12        | 0.05    | 1.65        | 0.58    | 0.68        | 0.20    | 0.27          | 0.09    |
| Q <sub>2</sub>     | 1.22        | 0.44    | 0.24        | 0.09    | 3.30        | 1.16    | 1.35        | 0.40    | 0.53          | 0.18    |
| Q <sub>10</sub>    | 1.70        | 0.73    | 0.33        | 0.14    | 6.22        | 3.14    | 2.11        | 0.71    | 0.75          | 0.32    |
| Q <sub>25</sub>    | 1.96        | 0.96    | 0.38        | 0.18    | 7.71        | 5.06    | 2.57        | 1.04    | 0.87          | 0.44    |
| Q <sub>50</sub>    | 2.16        | 1.18    | 0.42        | 0.21    | 8.82        | 7.13    | 2.96        | 1.04    | 0.96          | 0.56    |
| Q <sub>100</sub>   | 2.37        | 1.46    | 0.46        | 0.25    | 9.92        | 9.95    | 3.39        | 1.89    | 1.05          | 0.70    |

| Return Period Peak | SDW1A       |         | SDN3, SDN3X |         | Combined SDN2X/SDN4/SDN4X |         | Miller Creek at Detention Facility |         |
|--------------------|-------------|---------|-------------|---------|---------------------------|---------|------------------------------------|---------|
|                    | Pre-Project | Project | Pre-Project | Project | Pre-Project               | Project | Pre-Project                        | Project |
| 1/2 Q <sub>2</sub> | 0.15        | 0.006   | 0.71        | 0.25    | 0.57                      | 0.20    | 19.66                              | 19.78   |
| Q <sub>2</sub>     | 0.30        | 0.01    | 1.41        | 0.50    | 1.15                      | 0.39    | 39.31                              | 39.56   |
| Q <sub>10</sub>    | 0.58        | 0.05    | 2.01        | 0.83    | 1.61                      | 0.68    | 56.11                              | 56.41   |
| Q <sub>25</sub>    | 0.79        | 0.12    | 2.33        | 1.06    | 1.86                      | 0.95    | 64.06                              | 64.38   |
| Q <sub>50</sub>    | 0.99        | 0.25    | 2.58        | 1.27    | 2.06                      | 1.22    | 69.82                              | 70.17   |
| Q <sub>100</sub>   | 1.24        | 0.52    | 2.84        | 1.52    | 2.26                      | 1.57    | 75.47                              | 75.85   |

| Return Period Peak | Miller Creek at SR509 |         | Walker Creek at South 12 <sup>th</sup> Street |         | SDNI        |         |
|--------------------|-----------------------|---------|-----------------------------------------------|---------|-------------|---------|
|                    | Pre-Project           | Project | Pre-Project                                   | Project | Pre-Project | Project |
| 1/2 Q <sub>2</sub> | 22.81                 | 22.72   | 1.65                                          | 0.58    | 0.28        | 0.12    |
| Q <sub>2</sub>     | 45.62                 | 45.44   | 3.30                                          | 1.16    | 0.56        | 0.24    |
| Q <sub>10</sub>    | 67.23                 | 65.61   | 6.22                                          | 3.14    | 0.79        | 0.40    |
| Q <sub>25</sub>    | 77.29                 | 74.82   | 7.71                                          | 5.06    | 0.91        | 0.54    |
| Q <sub>50</sub>    | 84.53                 | 81.38   | 8.82                                          | 7.13    | 1.00        | 0.67    |
| Q <sub>100</sub>   | 91.58                 | 87.72   | 9.92                                          | 9.95    | 1.10        | 0.82    |

**Table 6.1-4. Summary of flood peak flow frequency results for Des Moines Creek subbasins  
(all values are cfs).**

| Return Period<br>Peak | SASA <sup>a</sup> |         | SDS3        |         | SDS3A       |         |
|-----------------------|-------------------|---------|-------------|---------|-------------|---------|
|                       | Pre-Project       | Project | Pre-Project | Project | Pre-Project | Project |
| 1/2 Q <sub>2</sub>    | 31.95             | 13.57   | 6.03        | 2.40    | 1.23        | 1.52    |
| Q <sub>2</sub>        | 63.90             | 27.13   | 12.06       | 4.79    | 2.45        | 3.05    |
| Q <sub>10</sub>       | 97.35             | 44.54   | 21.07       | 10.85   | 4.28        | 7.80    |
| Q <sub>25</sub>       | 116.65            | 56.20   | 26.92       | 16.51   | 5.47        | 12.09   |
| Q <sub>50</sub>       | 132.17            | 66.34   | 31.92       | 22.46   | 6.49        | 16.50   |
| Q <sub>100</sub>      | 148.69            | 77.82   | 37.52       | 30.39   | 7.62        | 22.26   |

| Return Period<br>Peak | SDS4        |         | SDS - Point of Compliance |         |
|-----------------------|-------------|---------|---------------------------|---------|
|                       | Pre-Project | Project | Pre-Project               | Project |
| 1/2 Q <sub>2</sub>    | 0.86        | 0.35    | 8.06                      | 4.35    |
| Q <sub>2</sub>        | 1.72        | 0.69    | 16.11                     | 8.71    |
| Q <sub>10</sub>       | 2.65        | 1.29    | 28.45                     | 18.58   |
| Q <sub>25</sub>       | 3.21        | 1.80    | 36.55                     | 26.66   |
| Q <sub>50</sub>       | 3.67        | 2.29    | 43.51                     | 34.51   |
| Q <sub>100</sub>      | 4.17        | 2.92    | 51.33                     | 44.30   |

| Return Period<br>Peak | SDS7        |         | Des Moines Creek @ South 200 Street |         |
|-----------------------|-------------|---------|-------------------------------------|---------|
|                       | Pre-Project | Project | Pre-Project                         | Project |
| 1/2 Q <sub>2</sub>    | 1.47        | 0.64    | 55.72                               | 36.29   |
| Q <sub>2</sub>        | 2.94        | 1.28    | 111.45                              | 72.58   |
| Q <sub>10</sub>       | 5.23        | 2.84    | 184.86                              | 117.11  |
| Q <sub>25</sub>       | 6.73        | 4.45    | 231.02                              | 145.08  |
| Q <sub>50</sub>       | 8.03        | 6.25    | 269.81                              | 168.55  |
| Q <sub>100</sub>      | 9.48        | 8.77    | 312.64                              | 194.44  |

<sup>a</sup> STIA basins plus non-STIA basins D1 and D2 are routed to pond. Retrofitting is applied only to STIA drainage areas.

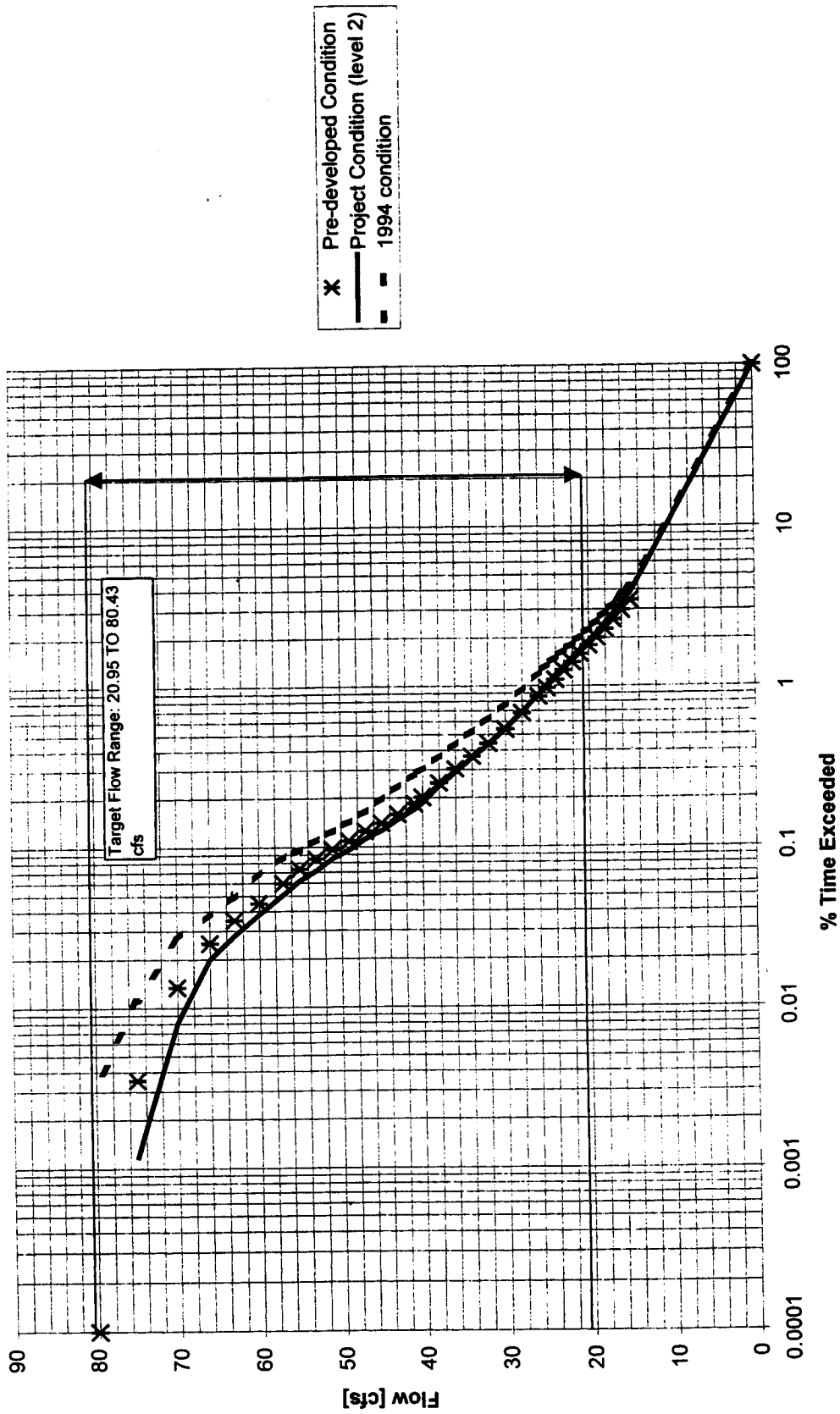


Figure 6.1-3  
Flow Duration Curve for  
Miller Creek at SR 509

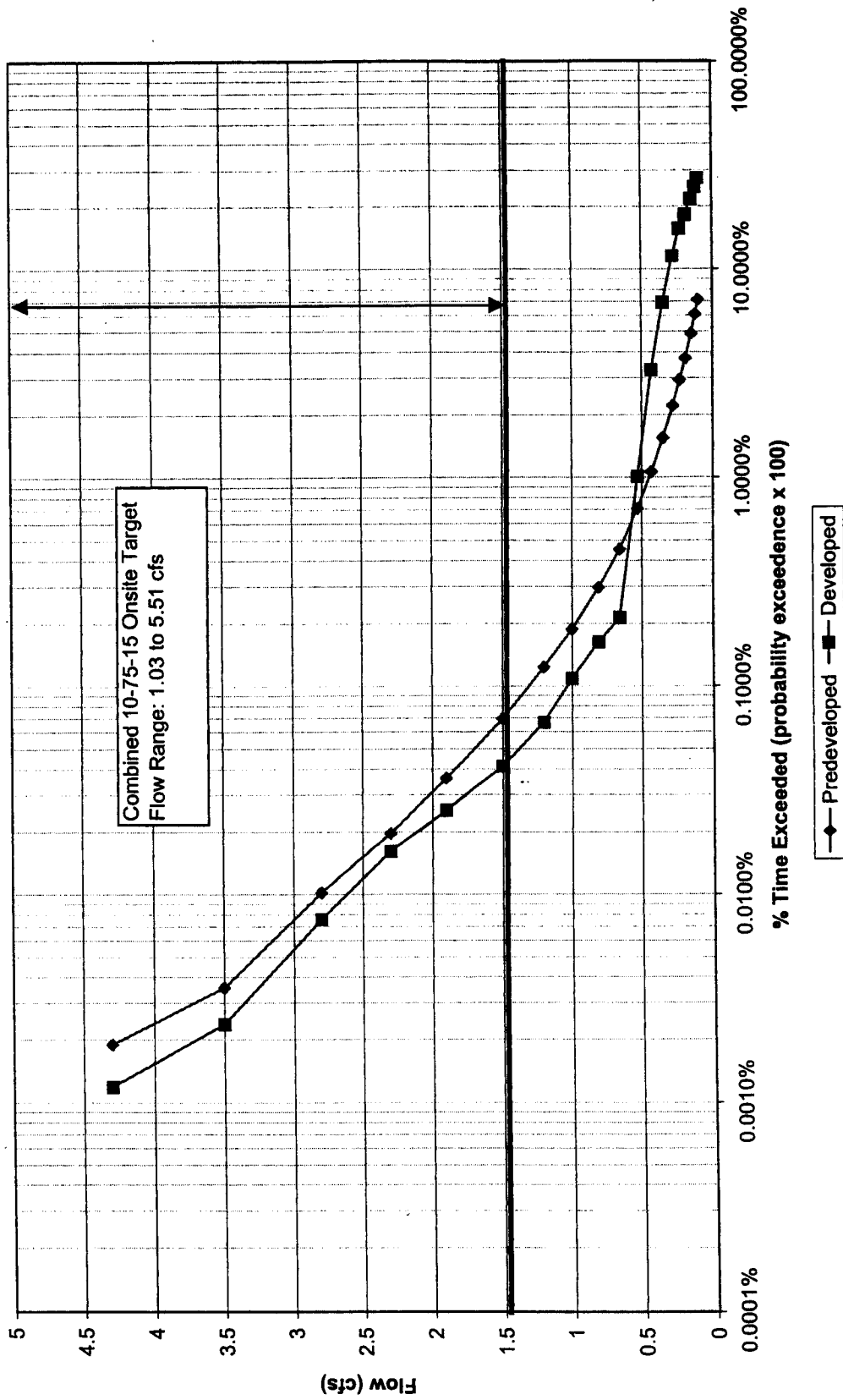


Figure 6.1-4  
Flow Duration Curve for  
Walker Creek at South 12th Street

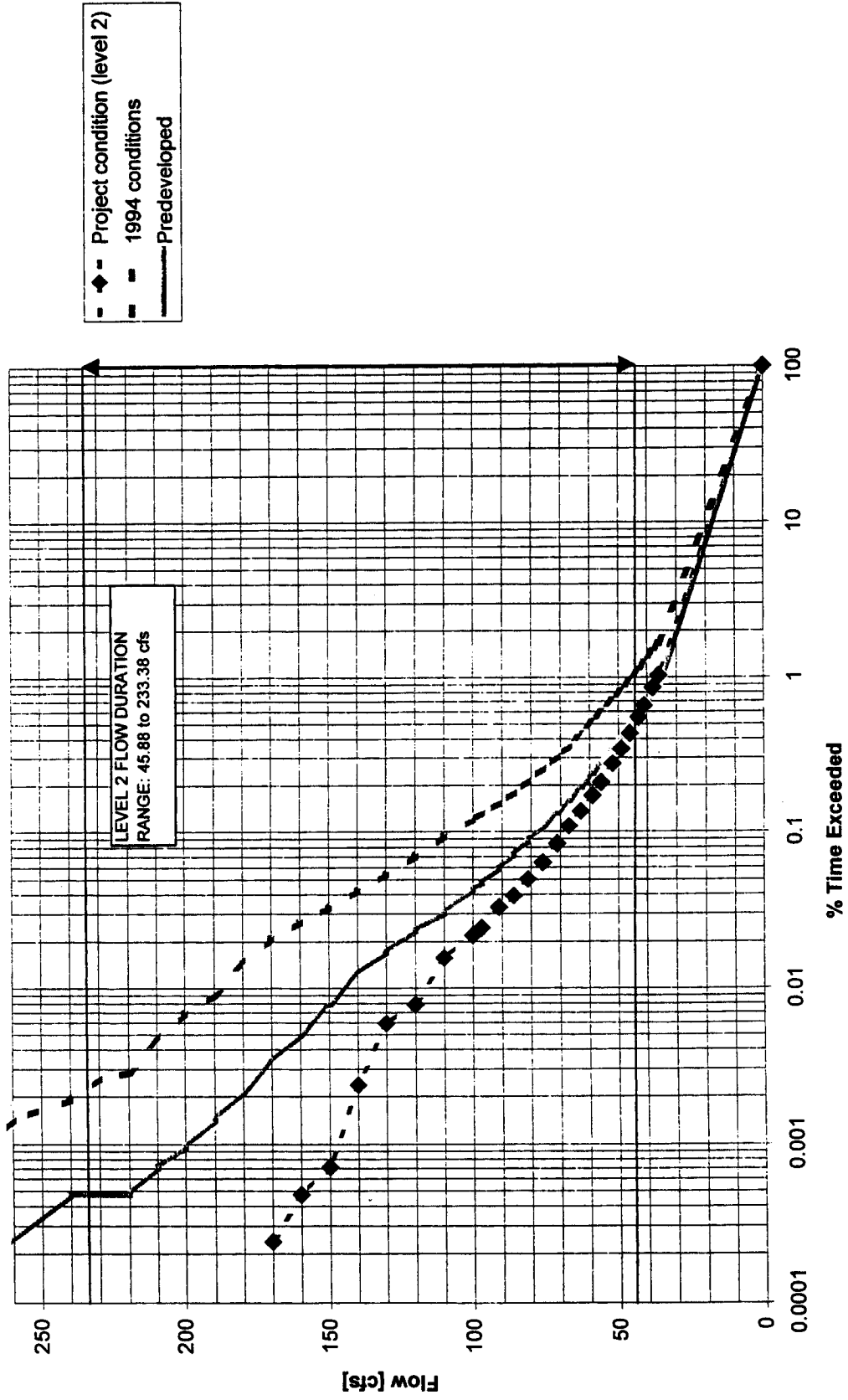


Figure 6.1-5  
 Flow Duration Curves for Des Moines  
 Creek at South 200th Street

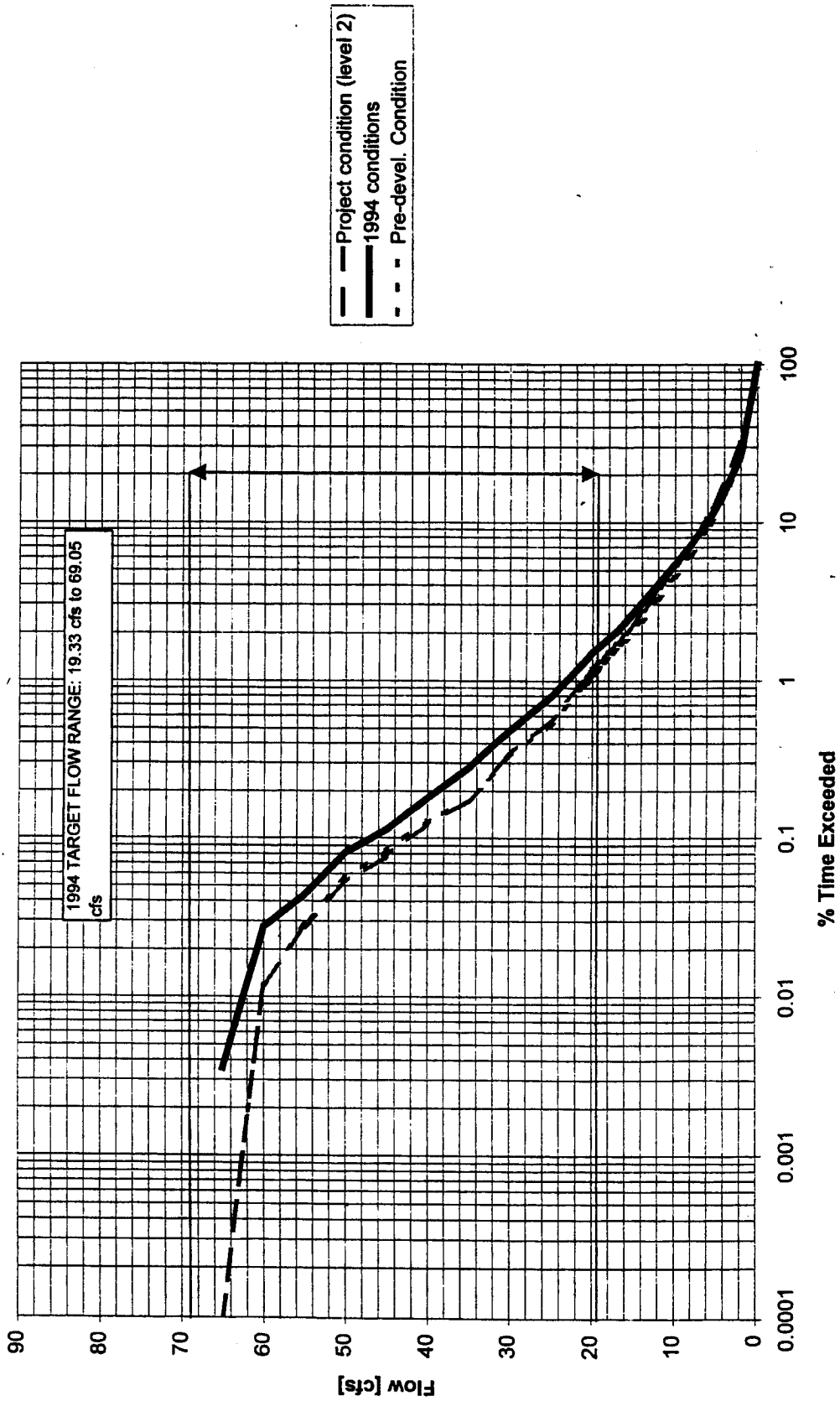


Figure 6.1-6  
 Flow Duration Curve for  
 Miller Creek at MCDF

### 6.1.2 Base Flow Impacts

Hydrologic modeling has also demonstrated a potential base flow impact due to the Master Plan Update improvements (Parametrix 2000a, 2001a). The HSPF model was used to analyze the potential hydrologic effects on stream base flow<sup>41</sup> after construction of the project in pervious areas. Results for the pre-project base condition (1994) were compared to the developed project condition (2006) in Miller, Walker, and Des Moines Creeks. Potential base flow changes were evaluated using a comparison between pre-project and project stream flow conditions during the typically driest times of year (August and September). Using HSPF, average changes in streamflow were simulated as shown in Table 6.1-5 (EarthTech 2000).

**Table 6.1-5. Estimated Low Streamflow Changes.**

|                  | Average Flows (cfs) |       |       |       |         |         |
|------------------|---------------------|-------|-------|-------|---------|---------|
|                  | 1994                |       | 2006  |       | Change  |         |
|                  | Aug                 | Sept  | Aug   | Sept  | Aug     | Sept    |
| Miller Creek     | 1.27                | 1.50  | 1.10  | 1.40  | - 0.17  | - 0.1   |
| Walker Creek     | 0.033               | 0.035 | 0.031 | 0.039 | - 0.002 | + 0.004 |
| Des Moines Creek | 1.08                | 1.64  | 1.07  | 1.73  | - 0.01  | + 0.09  |

If base flow impacts are large enough, the wetted stream area could be reduced and adversely affect critical habitat. However, base flow impacts estimated for Miller, Walker, and Des Moines Creeks are insignificant and would not measurably change the wetted area of critical habitat.

While the HSPF modeling summarized in Table 6.1-5 indicates reduced low streamflow, some mitigative elements of project hydrology have not been calculated and are beyond the capability of the HSPF model to closely evaluate. For example, stormwater from detention ponds SDW1A and SDW1B in the Miller Creek basin will be infiltrated. Infiltration will offset some low flow reduction, as water will be infiltrated in trenches near Miller Creek to slowly seep through the soil back into the stream long after the rain has stopped. Also, stormwater that infiltrates into the fill embankment (a large soil mass that will collect, store, and transmit water) and slowly leaks out has not been accounted for in the HSPF model due to limitations in the model to simulate these constructed systems. The relatively small reductions in low flow shown on Table 6.1-5 will in fact be even less due to the limitations of the HSPF model to model these positive effects. Additional details on base flow impacts are provided in the *Seattle-Tacoma Airport Master Plan Update Improvements Low Streamflow Analysis* (Earth Tech 2000).

#### 6.1.2.1 Effects of Peat Removal at Vacca Farm

Peat soils are often identified as having the ability to store water during wet periods and then release it slowly during dry periods, thereby augmenting base flows of associated streams. Excavation of peat soils during construction could alter hydrology and potentially affect base flow in Miller Creek.

<sup>41</sup> Base flow is defined as the streamflow generated by groundwater in undeveloped watersheds. It is sometimes referred to as dry-weather flow.



The peat soil at the Vacca Farm site is identified as “Rifle” peat–afibrous, woody peat. It forms in depressions on top of glacial outwash soils such as the Vashon advance outwash, a medium dense sand soil series mapped in the vicinity of the Miller Creek valley. The Soil Conservation Service (SCS) estimates the permeability of similar peat soils to be on the order of 0.63 to 2 inches per hour (moderate permeability). An estimate of field capacity (the soil water content after gravity drainage from the peat has ceased), based on SCS data, is 0.4 (relatively high soil water retention). In comparison, the underlying dense sand in the outwash material has a permeability estimated at less than 1.4 inches per hour, and an available water capacity of about 0.1. The total porosity of the peat is assumed to be 0.8 (relatively high, thus a conservative assumption of greater maximum water storage).

The quantity of peat removed that could potentially provide water storage is about 10,000 cy. Therefore, the peat could store  $(10,000 \text{ cy}) \times (27 \text{ cf/cy}) \times (0.8 - 0.4) = 108,000$  cubic ft of water. If the release rate to the stream were uniform during the drier months (May through September), the average daily flow would be on the order of  $(108,000 \text{ cubic ft}) / (160 \text{ days} \times 24 \text{ hours} \times 60 \text{ minutes} \times 60 \text{ seconds}) = 0.008$  cfs. This estimate is high because it neglects evapotranspiration, which reduces the amount of water actually available to release as streamflow. Furthermore, the timing of the release of water stored in the peat is not likely to be uniform throughout the summer–most release would occur during late spring and early summer (May and June), prior to minimum streamflows. Thus, the potential impact on base flows from peat removal is likely considerably less than 0.008 cfs; this is unlikely to affect aquatic habitat in Miller Creek. In addition, the mitigation actions described in Section 5 include removal of drainage ditches, which will slow soil drainage at the Vacca Farm site.

## 6.2 WATER QUALITY

The Port’s mitigation of potential water quality impacts is described in the *Comprehensive Stormwater Management Plan* (Parametrix 2000a, 2001a). Stormwater quality mitigation elements in the plan include the following:

- BMPs will meet or exceed stormwater quality treatment standards. BMPs will be applied to all new and redeveloped pollution-generating impervious surfaces (PGIS), and BMPs will be retrofitted to treat runoff from existing untreated PGIS where practicable. Upon completion of the Master Plan Update improvements and other anticipated projects (e.g., north terminal expansion), an estimated 499.4 acres (86 percent) of the STIA SDS will have water quality treatment BMPs, out of a total SDS PGIS area of 579.4 acres.
- Source control BMPs will be implemented for all PGIS, and regularly reviewed for additional or improved methods. Source controls are planned and implemented via the Port’s SWPPP for airport operations (Port of Seattle 1998).
- A landscape management plan is included in the SWPPP. The landscape management portions of the SWPPP are intended to control water quality impacts from managed vegetated areas, including chemical use, container disposal, integrated pest management, fertilizer application, weeding, pruning, and a prohibition of herbicide application near water courses.

- The IWS, a source control BMP, is designed to treat industrial wastewater from aircraft maintenance, fueling, and de-icing areas. The IWS is being upgraded so that storage overflows do not occur. The upgrade includes expansion of IWS Lagoon 3. The IWS upgrades are not a Master Plan Update project.
- Existing sources of stormwater pollutants will be removed from urban drainage areas. This includes removal of septic tanks, underground fuel storage tanks, untreated flows from lawns, streets, and driveways, and cultivated land located in stream floodplains and buffers.
- Projects will be implemented to enhance water quality such as flow augmentation, wetland restoration, stream restoration, and enhancement of riparian buffer zones within the Miller and Des Moines Creek basins.
- Hydrologic controls (peak flow and flow duration control, discussed in the flow control sections of the *Comprehensive Stormwater Management Plan*) will reduce instream erosion.
- During construction, TESC's will be applied in excess of Ecology Manual (Ecology 2001b) minimum requirements. TESC activities will include planning and implementing construction SWPPPs and monitoring plans for every individual Master Plan Update improvement activity, applying conventional TESC BMPs, providing advanced stormwater treatment where necessary and appropriate, supervising contractor erosion control compliance with an erosion control and stormwater specialist, and funding independent third-party oversight of construction erosion control and stormwater management and compliance.

As demonstrated in the *Comprehensive Stormwater Management Plan*, concentrations of pollutants in STIA stormwater are generally less than those in runoff from other residential, urban, and industrial areas in the region. As the Master Plan Update improvements will consist of similar activities and BMPs, these actions are expected to mitigate or prevent impacts. The Port's ongoing compliance with the Clean Water Act and, in turn, protection of STIA's receiving waters, are demonstrated through compliance with its Section 402 (NPDES) Permit, administered in Washington by Ecology (Ecology 1998). The Fact Sheet for the Port's NPDES Permit states that compliance with the effluent limitations and other conditions in the permit constitutes compliance with the Federal Water Pollution Control Act and the Washington Water Pollution Control Act (RCW 90.48).



## 7. OFF-SITE HABITAT MITIGATION: AUBURN WETLAND MITIGATION

The proposed Auburn wetland mitigation site is a 67-acre parcel of land located within the City of Auburn immediately west of the Green River (see Figure 1.2-1). This mitigation project is in WRIA 9 and designed to restore and enhance forested, shrub, emergent, and open-water wetland habitats on over 65 acres of the 67-acre site to compensate for wetlands unavoidably impacted by the Master Plan Update improvements within the same WRIA. The overall goal is to replace wetland habitat functions (especially for avian species) in an off-site location, in compliance with FAA Advisory Circular 150/5200-33 (FAA 1997b).<sup>42</sup> The Port proposes to restore or enhance existing emergent wetland with diverse forest, shrub, emergent, and open-water wetland habitat, and restore buffer areas at the Auburn site as mitigation for habitat impacts. A summary of wetland impacts resulting from the Master Plan Update projects, proposed compensatory mitigation for each wetland type, and the overall replacement ratios provided by the Auburn mitigation site are provided in Table 7.1-1.

**Table 7.1-1. Summary of wetland impacts and off-site compensatory design objectives for the proposed Master Plan Update improvements.**

| <b>Project Impact</b>                                                                                 | <b>Compensatory Design Objectives</b>                                                                                                                                               | <b>Acreage Provided<sup>1</sup></b>                                                                                           |
|-------------------------------------------------------------------------------------------------------|-------------------------------------------------------------------------------------------------------------------------------------------------------------------------------------|-------------------------------------------------------------------------------------------------------------------------------|
| Fill of 8.17 acres of forested wetland and loss of associated wildlife habitat.                       | Provide in-kind replacement of forested wetland functions and increase overall wildlife habitat function by creating/restoring emergent wetlands to create native forested habitat. | 17.20 acres of forested wetland                                                                                               |
|                                                                                                       | Enhance existing emergent wetlands to create native forested habitat.                                                                                                               | 19.50 acres of enhanced forested wetland                                                                                      |
| Fill of 2.98 acres of shrub wetland and loss of associated wildlife habitat.                          | Provide in-kind replacement of shrub wetland functions and increase overall wildlife habitat function by enhancing and restoring emergent wetlands.                                 | 6.00 acres of shrub wetland                                                                                                   |
| Fill of 7.22 acres of emergent wetland and loss of associated wildlife habitat.                       | Provide functional replacement of emergent wetlands and increase wildlife habitat function by restoring emergent wetland.                                                           | 6.20 acres of emergent wetland                                                                                                |
|                                                                                                       | Provide pockets of open-water habitat.                                                                                                                                              | 0.60 acre of open-water wetland                                                                                               |
| Protect the wetland from potential off-site disturbance and provide enhanced upland wildlife habitat. | Protect wetlands with 100-ft buffers that are densely planted with native tree and shrub vegetation.                                                                                | Approximately 15.90 acres of forested buffer protect the site from potential off-site disturbance and provide upland habitat. |

Wetland mitigation immediately adjacent to the existing airport is constrained by the need to avoid creating wildlife hazards (i.e., waterfowl and flocking bird habitat) near the airfield (FAA 1997b). Therefore, the focus of the on-site mitigation projects (Section 5) is to replace and enhance wetland functions, including hydrologic, water quality, aquatic habitat, and riparian support, to the extent

<sup>42</sup> The ACOE RGL 01-1 (ACOE 2001) recognizes air traffic concerns a factor in siting wetland mitigation.

practicable, while reducing existing wildlife hazards and avoiding the creation of new wildlife hazards. As a consequence, on-site projects will not create or enhance open-water or emergent wetland habitats that could attract waterfowl. Due to this constraint on-site, the Port proposes to include significant additional restoration, creation, and enhancement of palustrine forest, shrub, emergent, and open-water habitats at the Auburn mitigation site to compensate for project impacts to these habitats.

Much of the emergent wetland habitat impacted by the Master Plan Update projects is relatively low quality and has been significantly altered and degraded by development. The Miller and Des Moines Creek basins historically supported forested or shrub wetlands dominated by a diverse native flora. The vegetation in existing emergent wetlands filled or disturbed by the project is generally maintained by ongoing anthropogenic disturbance (i.e., mowing, golf course maintenance). In the absence of this disturbance, these wetlands would develop into forested or shrub wetlands. The emergent wetlands are also relatively low quality habitat for most wildlife species because of ongoing disturbance and a lack of vegetation diversity. Similarly, many of the existing shrub wetlands are dominated by non-native invasive species such as Himalayan blackberry, and in the absence of disturbance would develop into forested wetlands. Existing shrub wetlands also provide lower quality habitat due to frequent disturbance and lack of habitat diversity.

For these reasons, the off-site mitigation has been designed to provide improved avian habitat conditions relative to the existing wetlands lost near STIA. Off-site mitigation emphasizes the development of forested wetlands because, over time and in the absence of ongoing human disturbance, most of the wetlands impacted by the Master Plan Update projects would develop into forested wetlands similar to those historically found in the area. Therefore, the wetland mitigation provided at Auburn (see Table 7.1.1) is not strictly in-kind mitigation of habitat types, and creates a greater amount of generally higher quality forested wetlands compared to the lower quality emergent and shrub wetlands found near STIA.

This section describes the off-site mitigation and monitoring plan. Overall goals and design criteria are described in Section 7.1. The mitigation site and site selection process are described in Section 7.2. Section 7.3 contains a detailed description of the mitigation design, including a description of construction methods and implementation of the mitigation plan. Section 7.4 describes the implementation of the project at the mitigation site. Detailed plan sheets showing design elements are included in Appendix E.

## **7.1 GOALS, OBJECTIVES, AND DESIGN CRITERIA**

Goals, objectives, and design criteria for the Auburn off-site wetland mitigation have been developed to guide the mitigation design and ensure that overall mitigation objectives are met (Table 7.1-2). The wetland mitigation goals and objectives identified are designed to compensate for unavoidable wetland impacts, especially to wildlife habitat, by creating forested, shrub, emergent, and open-water replacement wetland habitat with a net gain in functional value and acreage.

**Table 7.1-2. Mitigation goals with associated design objectives and design criteria for the Auburn mitigation site.**

| Goals and Design Objectives                                                                                                                              | Design Criteria                                                                                                                                                                                                                                                                                                                                                                                                                                                                                                                                                                                                                                                                                                 |
|----------------------------------------------------------------------------------------------------------------------------------------------------------|-----------------------------------------------------------------------------------------------------------------------------------------------------------------------------------------------------------------------------------------------------------------------------------------------------------------------------------------------------------------------------------------------------------------------------------------------------------------------------------------------------------------------------------------------------------------------------------------------------------------------------------------------------------------------------------------------------------------|
| <b>Goal 1: Achieve no net loss of wetland acreage by constructing replacement habitats of forest, shrub, and emergent wetland with a forested buffer</b> |                                                                                                                                                                                                                                                                                                                                                                                                                                                                                                                                                                                                                                                                                                                 |
| Provide seasonal to permanent wetland hydrology appropriate for each wetland vegetation cover type.                                                      | <p>Use a perched water table to establish wetlands at the approximate final grades of:</p> <p style="text-align: center;"><u><b>East Basin</b></u></p> <p>Below 38 ft in open-water wetland<br/>           38 ft to 41 ft in emergent wetlands<br/>           41 ft to 42 ft in shrub wetlands<br/>           42 ft to 46 ft in forested wetlands</p> <p style="text-align: center;"><u><b>West Basin</b></u></p> <p>Below 42 ft in open-water wetland<br/>           42 ft to 44 ft in emergent wetlands<br/>           44 ft to 47 ft in shrub wetlands<br/>           47 ft to 49 ft in forested wetlands</p>                                                                                                |
| Provide in-kind replacement for impacts to 8.17 acres of forested wetland.                                                                               | <p>Plant five forested wetland plant associations that are similar in composition to naturally occurring plant associations. Use native deciduous and evergreen species such as black cottonwood, Oregon ash, red alder, western redcedar, and Sitka spruce.</p> <p>Forest communities will have a native shrub understory with species such as salmonberry (<i>Rubus spectabilis</i>), twinberry (<i>Lonicera involucrata</i>), red-osier dogwood, red elderberry (<i>Sambucus racemosa</i>), willows, and vine maple.</p> <p>Plant native tree species at densities greater than 280 per acre.</p> <p>Plant native shrub species in forested communities at densities greater than 1,800 plants per acre.</p> |
| Provide in-kind replacement for impacts to 2.98 acres of shrub wetland.                                                                                  | <p>Plant an association of native shrub wetland species that is similar in composition to naturally occurring shrub wetlands, including species such as Pacific willow, Hooker's willow, Sitka willow, red-osier dogwood, and twinberry.</p> <p>Plant native shrub species at densities greater than 2,100 plants per acre.</p>                                                                                                                                                                                                                                                                                                                                                                                 |
| Provide replacement for impacts to 7.22 acres of emergent wetland.                                                                                       | <p>Plant an association of native emergent wetland species similar in composition to native emergent wetlands. Use native species that are suited to seasonally and/or permanently flooded conditions, such as water parsley (<i>Oenanthe javanica</i>), hardstem bulrush (<i>Schoenoplectus acutus</i>), and common spikerush (<i>Eleocharis palustris</i>).</p> <p>Plant native emergent species in approximately 0.05-acre monotypic patches at densities greater than 10,000 plants per acre (approximately 24 inches on-center).</p>                                                                                                                                                                       |
| Provide a forested buffer around the mitigation site to enhance functions and protect the wetland mitigation.                                            | <p>Establish a 100-ft-wide forested buffer around the perimeter of the mitigation site.</p>                                                                                                                                                                                                                                                                                                                                                                                                                                                                                                                                                                                                                     |

**Table 7.1-2. Mitigation goals with associated design objectives, design criteria, and final performance standards for the Auburn mitigation site (continued).**

| <b>Goals and Design Objectives</b>                                                                                                                           | <b>Design Criteria</b>                                                                                                                                                                                                                                                                                                                                                                                                        |
|--------------------------------------------------------------------------------------------------------------------------------------------------------------|-------------------------------------------------------------------------------------------------------------------------------------------------------------------------------------------------------------------------------------------------------------------------------------------------------------------------------------------------------------------------------------------------------------------------------|
| <b>Goal 2: Provide wildlife habitat replacement outside the 10,000-ft safety radius for aircraft operations</b>                                              |                                                                                                                                                                                                                                                                                                                                                                                                                               |
| Provide flooded emergent wetland habitat suitable for waterfowl feeding and resting during the winter and spring months.                                     | Emergent wetlands will satisfy the design criteria for wetland mitigation Goal 1. Additional design criteria for waterfowl habitat include:<br>Provide year-round shallow water with patches of emergent vegetation as feeding habitat for dabbling duck species.<br>Provide ponded water areas for resting habitat.                                                                                                          |
| Provide emergent, shrub, and forested wetland habitat with feeding and breeding for songbirds.                                                               | Forest, shrub, and emergent wetlands will satisfy the design criteria for wetland mitigation Goal 1. Additional design criteria for songbird habitat include:<br>Plant forested wetland adjacent to shrub, emergent, and open-water habitats.<br>Plant portions of the forested wetland with shrub understory species to provide a multiple-layered canopy adjacent to the shrub portion of the wetland.                      |
| Provide forested, shrub, and emergent wetland feeding and breeding habitat for small mammals.                                                                | Forest, shrub, and emergent wetlands will satisfy the design criteria identified for wetland mitigation Goal 1. Additional design criteria for small mammal habitat include:<br>Place LWD (stumps and logs of native species) throughout the forested wetland to provide year-round cover for small mammals.<br>Construct low hummocks in the shrub wetland areas to provide non-saturated soils for burrowing small mammals. |
| Provide breeding habitat for amphibians.                                                                                                                     | Forest, shrub, and emergent-wetlands will satisfy the design criteria for wetland mitigation Goal 1. Additional design criteria for amphibian habitat include:<br>Provide attachment substrate for breeding amphibian species in areas of ponded water.                                                                                                                                                                       |
| <b>Goal 3: Provide replacement wildlife habitat that increases overall habitat functions</b>                                                                 |                                                                                                                                                                                                                                                                                                                                                                                                                               |
| Consolidate mitigation for impacts to many small, discontinuous wetlands into a single, larger wetland to provide a more diverse aggregate of habitat types. | Construct a contiguous wetland system with forested, shrub, and emergent wetland types and wildlife habitat features that provide in-kind and out-of-kind habitat replacement.                                                                                                                                                                                                                                                |
| Assure long-term protection of the mitigation site.                                                                                                          | Screen the wetland from off-site areas and install fencing around the perimeter.<br>No public trails will be permitted on the mitigation site.                                                                                                                                                                                                                                                                                |
| <b>Goal 4: Enhance the existing 19.5-acre emergent wetland at the Auburn site</b>                                                                            |                                                                                                                                                                                                                                                                                                                                                                                                                               |
| Enhance functions of approximately 19.5 acres of degraded emergent wetland.                                                                                  | Plant existing wetland with native trees and shrubs at densities greater than 2,100 individual plants per acre for shrubs and greater than 280 stems per acre for native trees.                                                                                                                                                                                                                                               |

### **7.1.1 Goals and Objectives**

The general mitigation goals for the Auburn site are as follows:

- Achieve an overall increase in wetland acreage and functional replacement at a mitigation ratio of at least 2:1.
- Mitigate lost habitat functions of the Master Plan Update improvements outside of the 10,000-ft aircraft operations safety radius of STIA to protect public safety and reduce wildlife hazards to aircraft.
- Create diverse wetland habitats (including forested, shrub, open water, and emergent) as well as upland forested habitat on a large site adjacent to existing habitat corridors along the Green River.
- Enhance wetland functions in the existing degraded wetlands, which are dominated by non-native species, by converting them to diverse, native forested, shrub, and emergent wetlands.
- Provide long-term protection for the mitigation site by providing a 100-ft forested buffer around the perimeter of the site.

## **7.2 WETLAND MITIGATION SITE**

The mitigation site chosen for off-site compensatory mitigation for the Master Plan Update improvements is described in the following sections.

### **7.2.1 Site Description**

The mitigation area is part of a 67-acre parcel located within the City of Auburn immediately west of the Green River (Figure 7.2-1). The site is nearly level but gradually slopes from the eastern (approximately 52 ft in elevation) and southeastern boundaries to approximately 45 ft in elevation in the northwest corner. The undeveloped parcel has been farmed in the recent past, and currently supports a mix of upland and wetland pasture grasses and forbs that are common on abandoned agricultural land in the Puget Sound basin. The mitigation site is located between 100 and 150 ft west of the OHWM of the adjacent Green River.<sup>43</sup>

The site is bounded by a variety of land uses, including active agriculture fields to the north and south; undeveloped land, multi-family housing and a drive-in theater to the west; and the Green River, patches of riparian forest, and undeveloped, forested slopes to the east. The site was previously zoned single-family residential (R2) by the City of Auburn, and the 1995 Comprehensive Plan designation is single-family (Auburn 1995). In 1998, a new section was added to the City's zoning ordinance that allows wetland mitigation to occur in R2 zoning. The mitigation site is located within the Draft Mill Creek Special Areas Management Plan (SAMP) (ACOE 1997). The relationship of this project to the Draft SAMP is discussed in Section 7.2.3.

---

<sup>43</sup> Approximately 1.62 acres along the eastern boundary of the 67-acre site is set aside for potential development as part of a regional trail that may be built by King County.



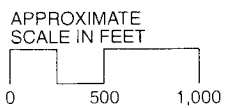
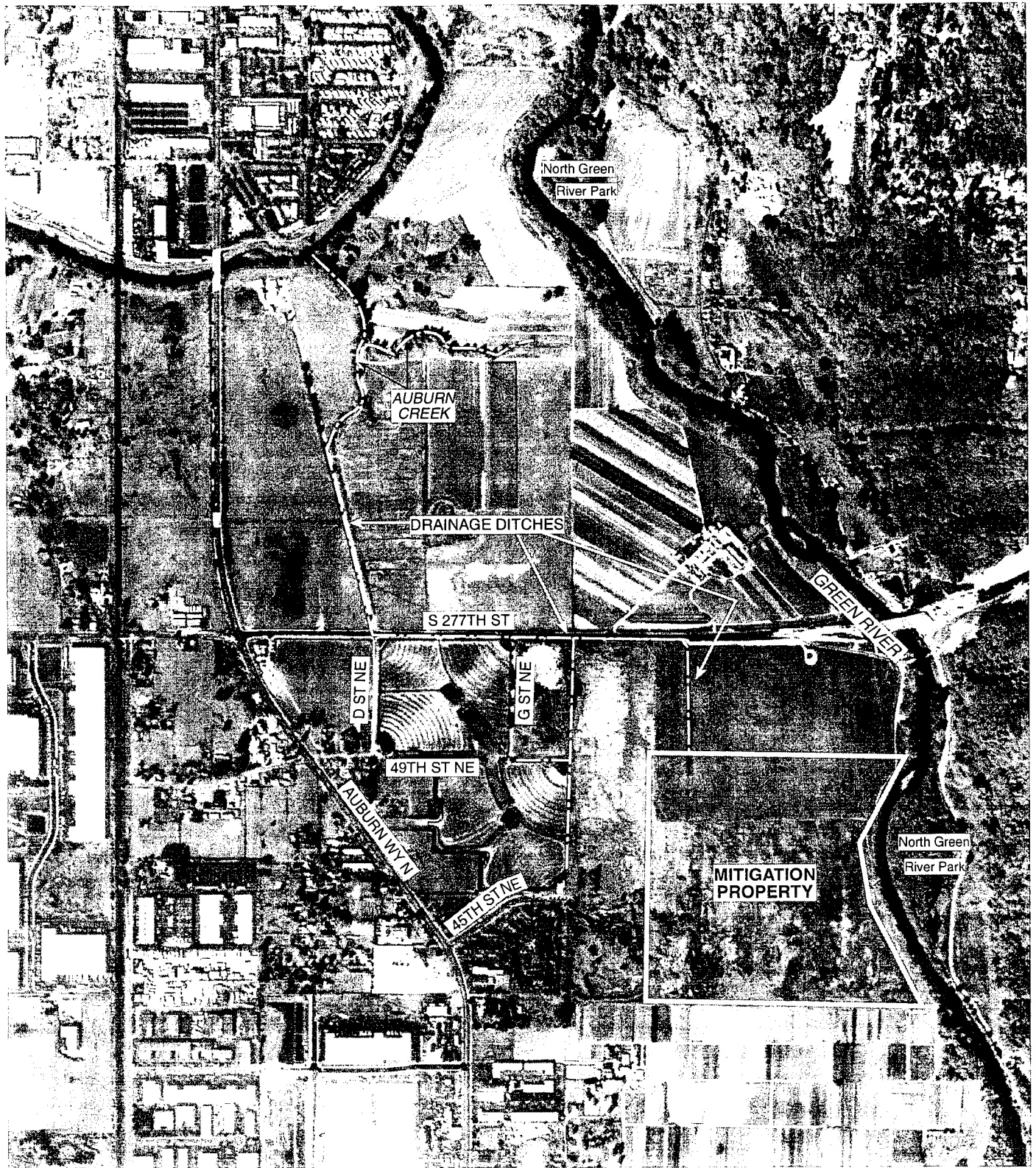


Figure 7.2-1  
Aerial Photograph of the Auburn  
Wetland Mitigation Site (1999)

Three jurisdictional wetlands were delineated on the mitigation site. Wetland 1 extends from the northwest corner to the south-central portion of the site (Figure 7.2-2) and covers 18.89 acres of the site. The wetland also extends off-site to the west, through the access easement for the site. Wetland 2 is adjacent to Wetland 1 in the south-central portion of the site, and is about 0.60 acre in size. Wetland 3 is located in the north-central portion of the site and is about 0.01 acre in size (Parametrix 2000b). Descriptions of site hydrology, soils, and vegetation of the wetland and upland portions of the site are included in the following sections.

## **7.2.2 Ownership**

The Port owns the entire 67-acre site and has a permanent access easement on the western side of the property (Appendix E, Sheet C2). Construction of the mitigation project requires temporary construction access easements, and a temporary drainage and construction easement that will allow the Port to modify an existing drainage ditch for drainage related to construction of the wetlands. A permanent easement allows monitoring and maintenance following construction. The Port has obtained these easements.

### **7.2.2.1 Construction Access**

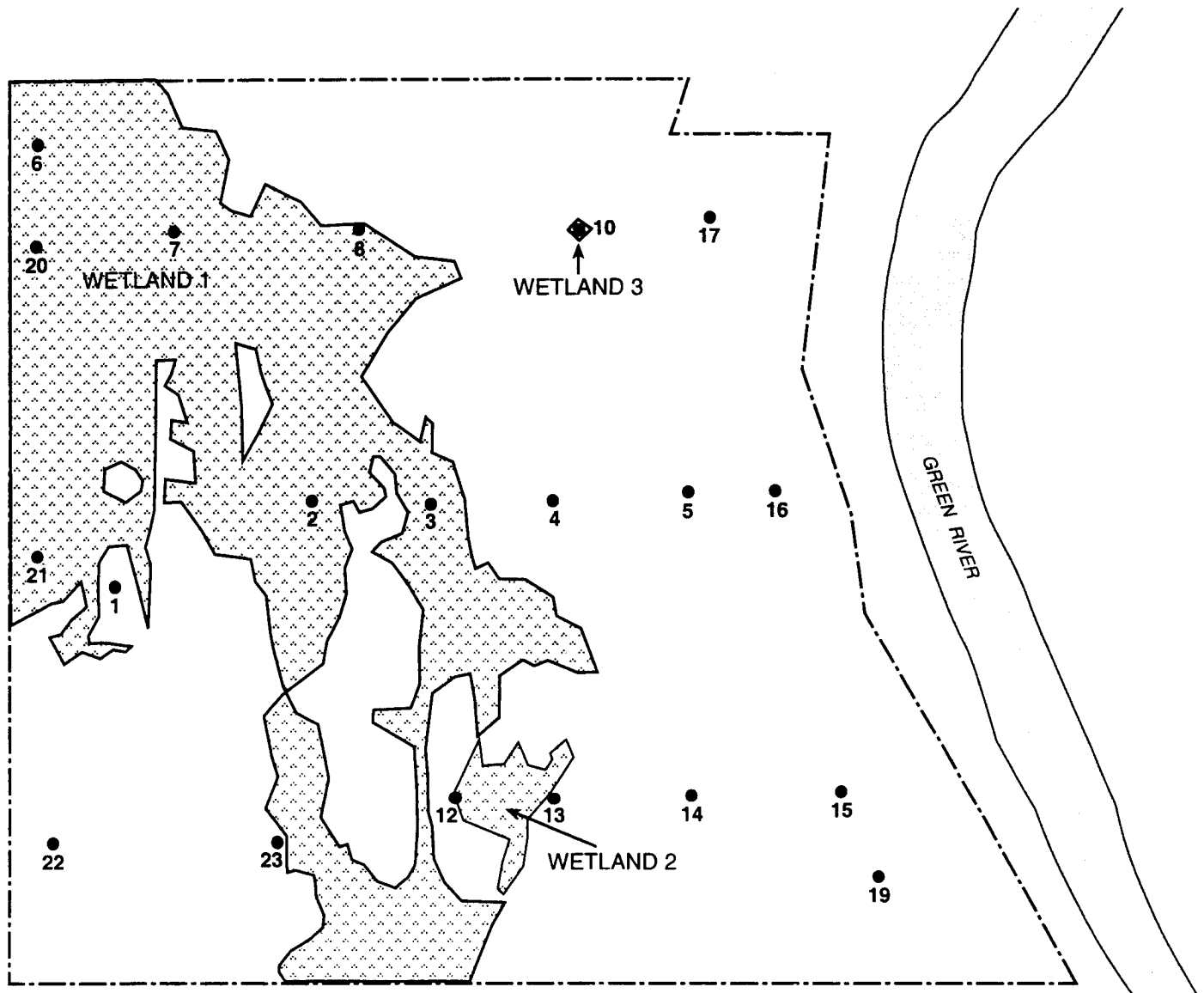
The Port has procured temporary construction and access easements from property owners to the west of the site for construction access to the mitigation project. As of December 2000, the Port had completed easement agreements from two property owners and was in the process of completing negotiations with three other owners.

### **7.2.2.2 Drainage Easement**

The Port has also procured a drainage and construction easement across the property north of the mitigation site (Appendix E, Sheet C2). The purpose of this easement is to grant the Port the right to modify an existing channel for drainage purposes related to construction of the mitigation project. The easement grants the Port the right to use this channel for the temporary discharge of water from dewatering wells to be used during excavation and construction of the mitigation wetlands. During dewatering, drainage water from the Port's property will be temporarily channeled to the existing outfall into the Green River at South 277<sup>th</sup> Street. Other than during construction dewatering, drainage water from the mitigation site will flow north through existing drainage channels along and under 277<sup>th</sup> Street, and then north to the Green River (see Section 7.2.2.3). The temporary drainage and construction easement will remain in use until a permanent flood channel is constructed across the property to the north.

### **7.2.2.3 Permanent Flood Channel**

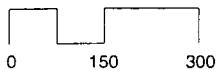
Construction of a permanent flood channel is a condition of the ILA between the Port and the City of Auburn. The ILA requires the Port to construct, or with the consent of the City, to pay the cost of constructing the floodway channel. The ILA requires that the flood channel be located in a mutually agreed upon location across the property to the north of the mitigation site (i.e., the Bristol



Note: See Appendix E Sheet C2 for more information.



APPROXIMATE  
SCALE IN FEET



Existing Wetland



Well Location



Site Boundary (Approximate)

**Figure 7.2-2**  
**Wetlands and Shallow Ground-**  
**water Monitoring Well Locations**  
**on the Wetland Mitigation Site,**  
**Auburn, Washington**

property). The Port is currently working with the City of Auburn and Bristol on the design and location of the floodway channel. Although a final determination has not been made as of December 2000, the existing channel is the most probable location of the permanent floodway channel (Appendix E, Sheet C2). Widening and deepening the existing drainage channel to construct the permanent floodway will impact a maximum of 2.2 acres of Waters of the U.S.<sup>44</sup>, and these impacts have been included in the project's CWA 404 permit application.

### **7.2.3 Rationale for Selection**

Mitigation site selection began with a review of the established goals as outlined in Section 7.1.1. The general site criteria required to meet these goals are similar to those listed by Castelle et al. (1992) and are listed below:

- A large non-wetland site, greater than 50 acres in size, with evidence of a seasonally high water table
- A non-forested site (to allow for significant net habitat improvements) adjacent to a higher quality habitat area (i.e., the Green River riparian corridor)
- A site with relatively flat topography
- A vacant or substantially vacant site
- A site available for purchase by the Port
- A site at least 10,000 ft from proposed or existing runways as recommended by the FAA (FAA 1997b)

The recommended preference for selecting wetland mitigation sites in the State of Washington is as follows: (1) on-site and in-kind; (2) off-site, within the watershed, and in-kind; (3) off-site, out of the watershed, and in-kind; and (4) off-site, out of the watershed, and out-of-kind (Ecology 1990). The Port's mitigation for wetland impacts follows these recommendations and the majority of mitigation for most wetland functions is located on-site, but outside of the STIA operations area to avoid hazards to aircraft. However, creating new wetland habitat within the STIA operations area was eliminated from consideration because the site criteria listed above could not be met. Additional on-site mitigation near STIA was not considered because it could be subject to degradation from wildlife control for safety reasons. Therefore, consideration of off-site mitigation was necessary.

#### **7.2.3.1 Wetland Mitigation and Aircraft Safety**

Bird-aircraft collisions (bird strikes) are a significant concern to the Port, the FAA, and the aviation community in general. Bird strikes threaten passenger safety, result in costly aircraft repair, cause passenger delays, and decrease revenue for commercial air carriers (Soloman 1973; Seubert 1977).

---

<sup>44</sup> This estimate is based on a drainage channel of about 1,200 linear feet that requires a construction footprint averaging 80 feet in width. It is assumed this channel is constructed in existing drainage ditches or abandoned farmland that are Waters of the U.S.

In the United States, annual costs due to bird strikes have been estimated to be \$112 million to military aircraft (Conover et al. 1996). Conover et al. (1996) estimate that for civilian aviation, about 33 percent of bird strikes are unreported, and that the annual rate for civilian aircraft is 6,240 strikes (the cost of these strikes was not estimated). Annual loss of life associated with bird strikes is less than three fatalities for all branches of the military, and 3.7 fatalities for civilian/commercial aviation (Conover et al. 1996). For these reasons, bird control in and around airports has become an important component of airport management.

The reported bird strikes at STIA are summarized in Table 7.2-1. The FAA (as part of the Part 139 Airport Certification Program) requires STIA to maintain and implement a WHMP (USDA 2000) to minimize bird strike hazards. Because of certification requirements and the Port's desire to maintain safe aircraft operations, it is compelled (where feasible) to eliminate bird hazards as part of the management plan. These hazards can be eliminated or reduced by hazing (scaring) birds from problem areas, killing wildlife (per permits issued by the USFWS), or modifying habitat so it is no longer suitable for wildlife creating the hazards.

**Table 7.2-1. Summary of reported bird strikes at Seattle-Tacoma International Airport (1979-1999).**

| Year           | Number of Strikes <sup>a</sup> |
|----------------|--------------------------------|
| 1979           | 5                              |
| 1980           | 8                              |
| 1981           | 14                             |
| 1982           | 4                              |
| 1983           | 8                              |
| 1984           | 3                              |
| 1985           | 11                             |
| 1986           | 12                             |
| 1987           | 11                             |
| 1988           | 7                              |
| 1989           | 13                             |
| 1990           | 35                             |
| 1991           | 22                             |
| 1992           | 13                             |
| 1993           | 14                             |
| 1994           | 22                             |
| 1995           | 20                             |
| 1996           | 27                             |
| 1997           | 27 <sup>b</sup>                |
| 1998           | 13 <sup>b</sup>                |
| 1999           | 21                             |
| <b>Average</b> | <b>14.8</b>                    |

<sup>a</sup> Some strike events may involve more than 1 bird.

<sup>b</sup> These numbers include carcasses found near the airfield.

FAA policy regarding wildlife attractants near airports includes the position that any activity or land use on or near an airport that threatens aircraft safety by attracting or sustaining hazardous wildlife is not a compatible land use (FAA 1997b). The FAA recommends all new wildlife attractants be 10,000 ft from turbine aircraft movement areas (AMAs) and 5 miles from an airport where wildlife could be attracted to or across the airport's approach or departure airspace. The FAA and the Port believe that wetland mitigation created as habitat for wildlife is a land use that should not occur near STIA.

There are compelling reasons to support decisions to mitigate for wildlife habitat mitigation greater than 10,000 ft from active runways. *Port of Seattle Position Paper re: Off-Airport Mitigation of Wetland Wildlife Habitat Function* (Port of Seattle 1998b) provides detailed explanation of off-airport mitigation needs. The reasons for off-airport mitigation discussed in that paper are summarized as follows:

- Creation of wetland wildlife habitat near the airport would increase the hazards to passenger safety. In the United States, more than 1,700 bird strikes occur each year. Worldwide since 1995, 74 people have been killed as a result of bird strikes and four large aircraft have been destroyed. For these reasons, FAA Advisory Circular 150/5200-33 recommends locating replacement wetlands more than 10,000 ft from runways serving turbine-engine airplanes. The FAA and the Department of Agriculture Animal Damage Control Division believe strongly that wetland wildlife habitat should not be created near STIA.
- If the Port were to create wetland wildlife habitat near the airport, it would be required to manage the wetland to prevent its attraction to birds. These management activities could be directly contrary to the key purpose of creating the habitat.
- The FAA has required, as a condition of its approval of the STIA improvements and as a condition of federal funding, that the Port comply with the FAA Advisory Circular and locate the replacement wetlands in Auburn. If the Port did not follow this requirement, it would likely lose essential federal funding for the airport projects.
- Constructing a replacement wetland in proximity to the airport raises liability concerns for the Port. Federal courts have found airport operators liable for failing to mitigate and warn pilots of wildlife hazards.

Considering the Port's and the FAA's mandate to provide a safe environment for aircraft operations, the construction of wetland mitigation to provide wildlife habitat is not feasible near (within 10,000 ft) an existing or proposed runway. A mitigation project designed to provide forest and shrub wetland (to discourage waterfowl use and replace functions in-kind) could attract additional numbers of birds known to be a strike hazard at the airport. While the mitigation is planned to avoid attracting other birds, it is potential habitat to many species. These include flocking birds (starlings, blackbirds, and pigeons), raptors (owls and hawks), and other common passerine (perching) birds. If increased numbers require management actions by the Port and FAA (such as modification of the mitigation site to discourage wildlife use), management would be contrary to federal and state wetland regulations and policies regarding mitigation.

**AR 049314**

The Port is attempting to decrease the aircraft/bird strike hazard at STIA as described in the WHMP (USDA 2000). The addition of new wildlife habitat near airport runways could undermine the ongoing effort to maintain and enhance airport safety and would not meet the goals of the Master Plan Update in which landing and takeoff safety is a major consideration.

### 7.2.3.2 On-site Locations

A GIS database (Puget Sound Regional Council 1994) was used to locate potential mitigation sites within the Miller Creek and Des Moines Creek watersheds. The GIS program identified all undeveloped, non-forested, non-wetland sites with average slopes less than 5 percent. It was assumed that, if available for purchase, these were the minimum criteria necessary for a suitable mitigation site. Based on these criteria, 19 potential mitigation sites were identified (Figure 7.2-3). The suitability of the sites (although all are within the 10,000-ft radius of concern for wildlife hazards to aircraft [FAA 1997b]) for wetland mitigation was evaluated during site visits on August 28, 1996 (Table 7.2-2).

The site selection criteria were altered because undeveloped sites greater than 50 acres were lacking in the two watersheds. For this level of analysis, it was assumed that drainage conditions on each site identified by the GIS program could be modified to retain adequate water to support wetlands, so evidence of high water tables was not considered. For this project, a mitigation site in excess of 50 acres is preferred because it would allow a mitigation ratio of at least 2:1 and allow protection of the site with adequate wetland buffers. In addition, sites greater than 50 acres would combine the functions of several small, isolated wetlands in a single large wetland mitigation project. This approach would enhance the probability of achieving mitigation goals, ensuring long-term protection, and ultimately providing wetland functions to compensate for project impacts (Federal Register 1995; Hurt et al. 1998). However, all sites greater than 10 acres were evaluated because there were few large undeveloped sites on suitable terrain in either watershed.

### 7.2.3.3 Off-site Locations

The search for off-site mitigation areas began by reviewing over 100 parcels for their suitability as wetland mitigation. The review focused on sites larger than 50 acres because of the acreage needed to mitigate impacts and the ecological and logistical advantages of developing mitigation on a single site. Other constraints identified for off-site areas included:

- Site selected should be in proximity to impact site and not conflict with other planned wetland mitigation projects in the Duwamish watershed
- Land not constrained by development restrictions (such as King County's Farmland Preservation Program)
- Land that is economically feasible for purchase and construction of desired mitigation
- Sites greater than 10,000 ft from proposed or existing STIA runways
- Sites greater than 5,000 ft from general aviation runways (for airports located within the Cities of Auburn and Kent)
- Sites located in WRIA 9

**AR 049315**



File: \source\papers\19-17\miller-and-desmoines.ppt, 1/17, 1/17, 1/17, 2/17 Date: April 27, 2017

AR 049316

- Road
- Major Highway
- Watershed Boundary
- Present Runways
- Proposed Third Runway, Runway Safety Areas, and Runway Extensions, Runway, Warehouse/ Parking or SASA Area
- Slope Less Than or Equal to 5%
- Non-Developed/Non-Forested
- Slope < 5% and Non-Developed/Non-Forested
- Potential Wetland Mitigation Site (Greater than 10 Acres)
- 10,000-Foot Radius From Proposed Runways
- City Boundary



**Figure 7.2-3**  
**Potential Mitigation Sites**  
**Evaluated in the Miller Creek**  
**and Des Moines Creek Watersheds**



Scale in Feet



**Table 7.2-2. Summary of potential mitigation sites analyzed within the Miller Creek and Des Moines Creek watersheds (see Figure 7.2-3).**

| Site | Watershed    | Acres | Existing Conditions                                                                                                                                                                                                                                                                                                                                                                                                                | Mitigation Limitations                                                                                                                                                                                                                                                                                                                                                                                                                                                                                                                                                                                                           |
|------|--------------|-------|------------------------------------------------------------------------------------------------------------------------------------------------------------------------------------------------------------------------------------------------------------------------------------------------------------------------------------------------------------------------------------------------------------------------------------|----------------------------------------------------------------------------------------------------------------------------------------------------------------------------------------------------------------------------------------------------------------------------------------------------------------------------------------------------------------------------------------------------------------------------------------------------------------------------------------------------------------------------------------------------------------------------------------------------------------------------------|
| 1    | Miller Creek | 55    | The site is within the direct flight path to the airport. It is within a vacated residential area and has been identified for development as the North SeaTac Park (which includes play fields, a picnic shelter, restrooms, a playground, parking, and trails), pursuant to an agreement between the Port and the City of SeaTac.                                                                                                 | Use of the site for wetland mitigation would eliminate use of much of the site as a community park.<br>The site is approximately 6,400 ft north of the existing runways. Enhancement of wildlife habitat in this area would increase wildlife hazards to aircraft.                                                                                                                                                                                                                                                                                                                                                               |
| 2    | Miller Creek | 14    | The area is within the direct flight path to the airport. It is in an abandoned residential area with scattered deciduous trees, blackberries, grasses, and weeds. The site drains from east to west into Tub Lake.                                                                                                                                                                                                                | Some slopes on the site are steeper than mapped in the GIS database, and only approximately 5 acres of the site are suitable for wetland creation. Therefore, this site is not large enough.<br>The site is 4,500 ft north of the existing runways, and enhancement of wildlife habitat in this area would increase hazards to aircraft.                                                                                                                                                                                                                                                                                         |
| 3    | Miller Creek | 33    | The area is in a vacated residential area in the direct flight path to the airport. Vegetation is largely comprised of blackberries, ornamental trees, grasses, and weeds. The smaller, northern portion of the site connects to the Tub Lake wetland on one side, with an approximate rise in elevation of 30 to 50 ft on other sides. The southern portion of the site is also topographically higher than the Tub Lake wetland. | The site is fragmented by three streets, which could be detrimental to wildlife.<br>The site is approximately 2,600 ft north of the nearest existing runway. Creation of wetland habitat at this site would increase wildlife hazards to aircraft.                                                                                                                                                                                                                                                                                                                                                                               |
| 4    | Miller Creek | 17    | The area is at a topographic high point in the direct flight path of the airport. There are patches of mixed deciduous and ornamental trees. A large water tower is in the northern portion of the site.                                                                                                                                                                                                                           | The area is not large enough to mitigate wetland impacts at one site, and there is no wildlife corridor to the other potential sites or other habitat areas. The site is within the fenced airport security area, which would preclude use of the wetland by some forms of wildlife, including deer, coyote, and fox.<br>The site is within the area of proposed Master Plan Update improvements where warehouse and parking is proposed.<br>This site is approximately 2,300 ft north of the nearest runway. Wetland creation would not be feasible due to the proximity of low-flying aircraft and increased wildlife hazards. |

Table 7.2-2. Summary of potential mitigation sites analyzed within the Miller Creek and Des Moines Creek watersheds (see Figure 7.2-3) (continued).

| Site               | Watershed                                                             | Acres | Existing Conditions                                                                                                                                           | Mitigation Limitations                                                                                                                                                                                                                                                                                                                                                                              |
|--------------------|-----------------------------------------------------------------------|-------|---------------------------------------------------------------------------------------------------------------------------------------------------------------|-----------------------------------------------------------------------------------------------------------------------------------------------------------------------------------------------------------------------------------------------------------------------------------------------------------------------------------------------------------------------------------------------------|
| 5                  | Miller Creek                                                          | 11    | The site is on a slope within the fenced airport security area. Patches of deciduous and ornamental trees are scattered throughout the site.                  | Most of the site will be developed as part of the Master Plan Update improvements. Only about 1 or 2 acres will remain after construction.                                                                                                                                                                                                                                                          |
| 6 and 7            | Miller Creek                                                          | 45    | These sites are grassy areas between the existing runways and taxiways within the airport operation area.                                                     | The proximity to existing airport operations (approximately 2,000 ft from existing runways and 1,000 ft from the proposed runway) would result in increased wildlife hazards to aircraft. Locating wetland habitat within the airport operation area is not feasible for safety reasons.                                                                                                            |
| 8                  | Miller Creek                                                          | 23    | This site consists of landscaped yards in a semi-rural residential area west of the airport. Miller Creek flows through portions of the relatively flat site. | The eastern portion of this site is within the fill footprint for the proposed runway. The remaining portion of the site is not large enough to mitigate wetland impacts. The mitigation area would be isolated from other habitat areas by South 154th Street, the airport, and SR 509, which would not be conducive to optimal wildlife habitat.                                                  |
| 9                  | Des Moines Creek                                                      | 24    | The site is a cemetery.                                                                                                                                       | The mitigation area would be 3,100 ft southwest of the end of the nearest existing runway and 2,100 ft southwest of the end of the proposed runway. The site is approximately 1,000 ft directly west of the edge of the proposed runway. The proximity of airport operations increases the wildlife hazard to low-flying aircraft. It is not reasonable to locate wetland mitigation in a cemetery. |
| 10, 11, 13, and 14 | Miller Creek (sites 10 and 13) and Des Moines Creek (sites 11 and 14) | 100   | These sites are located between and adjacent to the existing runways and taxiways. They are grassy areas mowed and maintained for airport safety reasons.     | The proximity of the site (3,600 ft southeast of the end of the nearest runway and 2,600 ft east of the edge of the nearest runway) to runways presents a wildlife hazard to aircraft. Locating wetland habitat within the airport operations area is not feasible due to safety reasons.                                                                                                           |

**Table 7.2-2. Summary of potential mitigation sites analyzed within the Miller Creek and Des Moines Creek watersheds (see Figure 7.2-3) (continued).**

| Site | Watershed        | Acres | Existing Conditions                                                                                                                                                                                                                   | Mitigation Limitations                                                                                                                                                                                                                                                                                                                                                                                                                                                                                                                                                                                                                                                                                                                                                                                                                                                                                                                                                                                                                                                                                                                                                                                                                                                                                                                                                                                                                                                                                                                                                                |
|------|------------------|-------|---------------------------------------------------------------------------------------------------------------------------------------------------------------------------------------------------------------------------------------|---------------------------------------------------------------------------------------------------------------------------------------------------------------------------------------------------------------------------------------------------------------------------------------------------------------------------------------------------------------------------------------------------------------------------------------------------------------------------------------------------------------------------------------------------------------------------------------------------------------------------------------------------------------------------------------------------------------------------------------------------------------------------------------------------------------------------------------------------------------------------------------------------------------------------------------------------------------------------------------------------------------------------------------------------------------------------------------------------------------------------------------------------------------------------------------------------------------------------------------------------------------------------------------------------------------------------------------------------------------------------------------------------------------------------------------------------------------------------------------------------------------------------------------------------------------------------------------|
| 12   | Miller Creek     | 16    | This relatively flat area consists of large expanses of lawn bordered by roads, houses, and a large scrub/shrub wetland.                                                                                                              | <p>Wetland mitigation at this site would require displacement of additional residents.</p> <p>The site is not large enough to mitigate all of the wetland impacts at one location.</p> <p>The area is bordered by major roadways (SR 509 and Des Moines Way South) on two of the three sides, which would not be conducive to optimal wildlife habitat.</p> <p>Mitigation would be about 1,800 ft west of the proposed runway and approximately 4,500 ft from either end of the proposed runway. The proximity of the proposed runway to mitigation would increase the hazard to aircraft.</p> <p>Less than half of the site would be available for wetland mitigation due to the surrounding topography and the presence of existing wetland. The proximity of a trailer park, hotel, and single-family homes, and the small size of available upland area, make this site undesirable for wetland habitat mitigation.</p> <p>The site is roughly 5,200 ft east of the ends of the existing runways and 4,700 ft east of the edge of the nearest runway.</p> <p>Much of the area is included in the Master Plan Update improvement area (including the safety area currently under construction and the SASA). If the preferred alternative for the airport expansion is implemented, there would not be enough suitable land remaining for wetland creation.</p> <p>Mitigation at this site may not be protected in perpetuity due to the proximity of airport operations. It is approximately 1,500 ft south of Runway 34R, which would increase wildlife hazards to aircraft.</p> |
| 15   | Des Moines Creek | 11    | Site 15 is a horse pasture surrounded on three sides by steep slopes. A scrub/shrub wetland, which connects to Bow Lake, lies on the western side of the pasture. Single-family homes, a trailer park, and a hotel overlook the site. |                                                                                                                                                                                                                                                                                                                                                                                                                                                                                                                                                                                                                                                                                                                                                                                                                                                                                                                                                                                                                                                                                                                                                                                                                                                                                                                                                                                                                                                                                                                                                                                       |
| 16   | Des Moines Creek | 35    | Site 16 is located in the direct flight path and consists of the northern portion of Tye Valley Golf Course. Currently, a safety area for Runway 34R, which encroaches on the golf course, is under construction.                     |                                                                                                                                                                                                                                                                                                                                                                                                                                                                                                                                                                                                                                                                                                                                                                                                                                                                                                                                                                                                                                                                                                                                                                                                                                                                                                                                                                                                                                                                                                                                                                                       |

**Table 7.2-2. Summary of potential mitigation sites analyzed within the Miller Creek and Des Moines Creek watersheds (see Figure 7.2-3) (continued).**

| Site | Watershed        | Acres | Existing Conditions                                                                                                                                                                                                                                                                                            | Mitigation Limitations                                                                                                                                                                                                                                                                                                                                                                                                                                                                                                                                                                                                                                                                                                                                                                                                                                                                                                                                                                                           |
|------|------------------|-------|----------------------------------------------------------------------------------------------------------------------------------------------------------------------------------------------------------------------------------------------------------------------------------------------------------------|------------------------------------------------------------------------------------------------------------------------------------------------------------------------------------------------------------------------------------------------------------------------------------------------------------------------------------------------------------------------------------------------------------------------------------------------------------------------------------------------------------------------------------------------------------------------------------------------------------------------------------------------------------------------------------------------------------------------------------------------------------------------------------------------------------------------------------------------------------------------------------------------------------------------------------------------------------------------------------------------------------------|
| 17   | Des Moines Creek | 23    | This site is the southern portion of Tyee Valley Golf Course. It is bordered by a mixed forest to the west and south, residential and recreational uses to the east, and the northern portion of the golf course to the north. Des Moines Creek divides the northern and southern portions of the golf course. | The site would be confined by ongoing disturbances or developments, including the airport, the SASA area, and borrow areas for construction of the proposed runway, which is not conducive for wildlife habitat replacement. It is 2,100 ft directly south of the end of Runway 34R, which would result in increased wildlife hazards to aircraft.<br><br>There is not enough land to mitigate wetland impacts on one site that could be protected in perpetuity.<br><br>The necessary acreage required for compensatory mitigation could not be attained at this site. It is fragmented by homes and active roads, and residents would have to be displaced for mitigation.<br><br>The site is approximately 4,900 ft south of the existing runways and would increase wildlife hazards to aircraft.<br><br>The necessary acreage required for compensatory mitigation could not be attained at this site. It is fragmented by homes and active roads, and residents would have to be displaced for mitigation. |
| 18   | Des Moines Creek | 16    | This site consists of grass pastures and landscaped yards adjacent to a forested area on the west side and residential areas to the north, east, and south. Most of the site is on a topographically high area.                                                                                                | The site is approximately 4,900 ft south of the existing runways and would increase wildlife hazards to aircraft.<br><br>The necessary acreage required for compensatory mitigation could not be attained at this site. It is fragmented by homes and active roads, and residents would have to be displaced for mitigation.                                                                                                                                                                                                                                                                                                                                                                                                                                                                                                                                                                                                                                                                                     |
| 19   | Des Moines Creek | 12    | Site 19 consists of landscaped yards and some pasture area with a large forested area to the north. Most of the site is topographically high.                                                                                                                                                                  | Site 19 is approximately 5,200 ft south of the existing runways, and would increase wildlife hazards to aircraft.                                                                                                                                                                                                                                                                                                                                                                                                                                                                                                                                                                                                                                                                                                                                                                                                                                                                                                |

Note: Data compiled by Parametrix.

In addition to the above constraints, a preference was given to suitably sized, non-wetland areas that were close to surface water or other riparian habitat areas. The mitigation site would then provide ecological functions to off-site areas.

Of 11 sites larger than 50 acres, five were rejected as unsuitable due to the large amount of wetlands present or because they offered minimal opportunity for habitat improvement. Of the six remaining sites, two were not available for purchase, the development rights of two were owned by King County for farmland preservation, and one site had been purchased by the City of Kent for its own mitigation purposes.

The remaining site, analyzed in this plan, has several attributes that make it favorable for wetland mitigation. It is large enough to accommodate the entire wetland mitigation project and has physical features that could successfully support the proposed mitigation approach. These features include proximity to the Green River and a seasonally high water table.

The mitigation site is within the boundary of the Mill Creek SAMP (ACOE 1997). This mitigation project enhances existing wetlands and creates wetlands from upland areas, enhances the aquatic resources of the basin, and is consistent with the goals and objectives of the SAMP. The Draft SAMP identifies specific wetland areas on which development would be permitted by a Regional General Permit, and other areas where protection and enhancement of wetlands will be required. The overall goal of the Draft SAMP is to provide for aquatic resource protection and economic development in the Mill Creek basin while assuring no net loss of aquatic resource functions and values of the basin.

#### **7.2.4 Constraints**

No construction or implementation constraints have been identified that would affect the success of the wetland mitigation at the Auburn site.

#### **7.2.5 Ecological Assessment of the Mitigation Site**

The ecological conditions of the upland and wetland areas of the proposed mitigation site are discussed in this section. The existing wetlands are described in more detail in Appendix A of the *Wetland Delineation Report* (Parametrix 2000b).

##### **7.2.5.1 Existing Site Conditions**

#### **Vegetation**

The mitigation site consists primarily of abandoned agricultural land. Vegetation is a mix of native and non-native herbaceous species, including meadow foxtail (*Alopecurus pratensis*), Canada thistle, quackgrass (*Agropyron repens*), timothy (*Phleum pratense*), orchardgrass, colonial bentgrass (*Agrostis tenuis*), and patches of reed canarygrass (Table 7.2-3). Other non-native species scattered throughout the area include cocklebur (*Xanthium strumarium*), common dandelion (*Taraxacum officinale*), and climbing nightshade.

**Table 7.2-3 Plant species observed on the mitigation site and adjacent riparian areas during delineation site visits in October 1995 and 2000.**

|                               | Scientific Name                       | Common Name               | WIS *      |
|-------------------------------|---------------------------------------|---------------------------|------------|
| <b>Trees</b>                  | <i>Alnus rubra</i>                    | Red alder                 | FAC        |
|                               | <i>Crataegus douglasii</i>            | Douglas hawthorn          | FAC        |
|                               | <i>Fraxinus latifolia</i>             | Oregon ash                | FACW       |
|                               | <i>Populus trichocarpa</i>            | Black cottonwood          | FAC        |
|                               | <i>Prunus emarginata</i>              | Bitter cherry             | FACU       |
| <b>Shrubs</b>                 | <i>Acer circinatum</i>                | Vine maple                | FACU       |
|                               | <i>Cornus stolonifera</i>             | Red-osier dogwood         | FACW       |
|                               | <i>Corylus cornuta</i>                | Beaked hazelnut           | FACU       |
|                               | <i>Cytisus scoparius</i>              | Scots broom               | NI         |
|                               | <i>Populus trichocarpa</i> (saplings) | Black cottonwood          | FAC        |
|                               | <i>Rosa nutkana</i>                   | Nootka rose               | FAC        |
|                               | <i>Rosa pisocarpa</i>                 | Clustered wild rose       | FAC        |
|                               | <i>Rosa</i> sp.                       | Rose                      |            |
|                               | <i>Rubus discolor</i>                 | Himalayan blackberry      | FACU       |
|                               | <i>Rubus laciniatus</i>               | Evergreen blackberry      | FACU       |
|                               | <i>Rubus ursinus</i>                  | Pacific blackberry        | FACU       |
|                               | <i>Salix</i> spp.                     | Willow                    | FACW       |
|                               | <i>Salix scouleriana</i>              | Scouler willow            | FAC        |
|                               | <i>Symphoricarpos albus</i>           | Snowberry                 | FACU       |
|                               | <b>Herbs</b>                          | <i>Agropyron repens</i> * | Quackgrass |
| <i>Agrostis alba</i>          |                                       | Redtop                    | FACW       |
| <i>Agrostis tenuis</i> *      |                                       | Colonial bentgrass        | FAC        |
| <i>Alopecurus geniculatus</i> |                                       | Water foxtail             | OBL        |
| <i>Alopecurus pratensis</i> * |                                       | Meadow foxtail            | FACW       |
| <i>Cirsium arvense</i> *      |                                       | Canada thistle            | FACU       |
| <i>Cirsium vulgare</i> *      |                                       | Bull thistle              | FACU       |
| <i>Dactylis glomerata</i> *   |                                       | Orchardgrass              | FACU       |
| <i>Dipsacus sylvestris</i>    |                                       | Teasel                    | FAC        |
| <i>Eleocharis palustris</i>   |                                       | Creeping spikerush        | OBL        |
| <i>Epilobium ciliatum</i>     |                                       | Willow-herb               | FACW       |
| <i>Equisetum arvense</i>      |                                       | Field horsetail           | FAC        |
| <i>Festuca arundinacea</i> *  |                                       | Tall fescue               | FAC        |
| <i>Festuca rubra</i>          |                                       | Red fescue                | FAC+       |
| <i>Geranium</i> spp.          |                                       | Crane's-bill              | FACU       |
| <i>Holcus lanatus</i> *       |                                       | Common velvetgrass        | FAC        |
| <i>Juncus effusus</i>         |                                       | Soft rush                 | FACW       |
| <i>Juncus</i> spp.            |                                       | Rush                      | FACW       |
| <i>Lolium perenne</i>         |                                       | Perennial rye grass       | FACU       |

Table 7.2-3. Plant species observed on the mitigation site and adjacent riparian areas during delineation site visits in October 1995 and 2000 (continued).

| Scientific Name               | Common Name         | WIS <sup>a</sup> |
|-------------------------------|---------------------|------------------|
| <i>Lotus corniculatus</i>     | Birds foot trefoil  | FAC              |
| <i>Phalaris arundinacea</i> * | Reed canarygrass    | FACW             |
| <i>Phleum pratense</i> *      | Timothy             | FAC              |
| <i>Phragmites communis</i>    | Common reed         | FACW             |
| <i>Plantago lanceolata</i>    | English plantain    | FAC              |
| <i>Poa pratensis</i> *        | Kentucky bluegrass  | FAC              |
| <i>Polystichum munitum</i>    | Sword fern          | FACU             |
| <i>Ranunculus repens</i>      | Creeping buttercup  | FACW             |
| <i>Rumex crispus</i>          | Curly dock          | FAC              |
| <i>Scirpus acutus</i>         | Hard-stem bulrush   | OBL              |
| <i>Solanum dulcamara</i> *    | Climbing nightshade | FAC              |
| <i>Symphoricarpos albus</i>   | Snowberry           | FACU             |
| <i>Tanacetum vulgare</i> *    | Common tansy        | UPL              |
| <i>Taraxacum officinale</i>   | Common dandelion    | FACU             |
| <i>Trifolium pratense</i>     | Red clover          | FACU             |
| <i>Typha latifolia</i>        | Common cattail      | OBL              |
| <i>Xanthium strumarium</i>    | Cocklebur           | FAC              |

\* These species are dominant on portions of the site.

<sup>a</sup> Wetland Indicator Status (Table 7.2-4).

Table 7.2-4. The wetland indicator status (WIS) system for determining a species adaptation to wetland conditions.

| Category                   | Symbol | Definition                                                                                                                                                                            |
|----------------------------|--------|---------------------------------------------------------------------------------------------------------------------------------------------------------------------------------------|
| Obligate Wetland Plants    | OBL    | Obligate wetland plants occur almost always (estimated probability >99%) in wetlands under natural conditions, but may also occur rarely (estimated probability <1%) in non-wetlands. |
| Facultative Wetland Plants | FACW   | Facultative wetland plants usually occur (estimated probability 67% to 99%) in wetlands, but may also occur (estimated probability 1% to 33%) in non-wetlands.                        |
| Facultative Plants         | FAC    | Facultative plants with a similar likelihood (estimated probability 33% to 67%) of occurring in wetlands or non-wetlands.                                                             |
| Facultative Upland Plants  | FACU   | Facultative upland plants usually occur (estimated probability 67% to 99%) in non-wetlands, but also occur (estimated probability 1% to 33%) in wetlands.                             |
| Obligate Upland Plants     | UPL    | Upland plants occur almost always (estimated probability >99%) in non-wetlands under natural conditions.                                                                              |
|                            | +      | Used in conjunction with a category to indicate a somewhat greater probability to occur in wetlands.                                                                                  |
|                            | -      | Used in conjunction with a category to indicate a somewhat lower probability to occur in wetlands.                                                                                    |

Source: Environmental Laboratory (1987)

Three emergent wetlands are present at the Auburn site (totalling about 19.5 acres [see Figure 7.2-2]). The wetlands are dominated by non-native pasture grasses that include meadow foxtail, reedtop (*Agrostis alba*), colonial bentgrass, quackgrass, tall fescue, common velvetgrass, and patches of reed canarygrass. Other herbaceous species in the wetlands include soft rush (*Juncus effusus*) and creeping buttercup. Along the western edge of the site are scattered black cottonwood and red alder trees.

A variety of shrubs and trees are scattered along a fence line at the southern boundary of the site. Shrubs found along the fence line include Himalayan blackberry, vine maple, roses (*Rosa* sp.), snowberry (*Symphoricarpos albus*), and red-osier dogwood (*Cornus stolonifera*). Tree species present in this area are Douglas hawthorn (*Crataegus douglasii*), Oregon ash, and black cottonwood. The herbaceous community in this area is dominated by reed canarygrass.

In the summer of 1998, the northern one-fourth of the property was plowed and disced by a farmer leasing the land to the north.<sup>45</sup> Pasture grasses such as tall fescue (*Festuca arundinacea*) and perennial ryegrass (*Lolium perenne*) currently dominates this portion of the site, and weedy forbs such as bull thistle (*Cirsium vulgare*) and willowherb (*Epilobium ciliatum*).

### Hydrology

There are no natural surface water features on the mitigation site. Two streams, the Green River and Auburn Creek, are located near the mitigation site. The Green River flows from south to north about 100 to 150 ft east of the mitigation site. At this location, the river base elevation is about 12 to 15 ft below the site elevation. The river channel consists of a steep bank, largely vegetated with red alder and black cottonwood saplings. North of the mitigation site and north of South 277<sup>th</sup> Street, King County sensitive areas maps (King County 1990) shows an intermittent stream, Auburn Creek (see Figure 7.2-1). This stream drains pasture and farmland and flows into the Green River about 1 mile north of the mitigation site. At the confluence of Auburn Creek and the Green River, a small dike, culvert, and flap gate provide flood control.

Overland flow enters the site through a wetland drainageway, or shallow swale, that crosses the middle of the site. For short periods following heavy rainfall, this shallow swale contains surface flows and conveys water from south to north across the site. This shallow drainage swale is connected to the 100-year floodplain of the Green River at the very northwest corner of the site (Figure 7.2-4). The eastern portion of the mitigation site is not within the 100-year floodplain of the Green River because the eastern edge of the site is several feet higher than the 100-year flood elevation of the river (see Figure 7.2-4). A drainage ditch on the mitigation site conveys stormwater and surface water runoff from the northwestern portion of the site to other ditches along South 277<sup>th</sup> Street. This water eventually flows into the Green River via a series of drainage ditches also called Auburn Creek.

Since September 1995, the groundwater hydrology of the site has been monitored using shallow groundwater monitoring wells (see Figure 7.2-2). Three representative wells are presented in Figures 7.2-5 through 7.2-7. The well data indicate groundwater levels that are within 18 inches of the surface at a number of locations, and generally within 36 to 24 inches of the soil surface for extended periods of time during the late fall, winter, and early spring months. Wetlands on the

---

<sup>45</sup> The Port did not authorize this activity and the Port's property was not planted.



mitigation site appear to be largely supported by this seasonally high groundwater table. In addition, wetland hydrology is supported by on-site precipitation that perches in the low permeability soils, resulting in saturated soils and extensive areas of shallow surface water ponding during the rainy season (see Figures 7.2-5 through 7.2-7).

At all well sites, groundwater elevations were lowest in late summer and early fall. Groundwater elevations were highest during and immediately after winter and early spring rains. Groundwater monitoring data show that following early fall precipitation (October, November) and subsequent soil saturation, groundwater elevations on the mitigation site rise by approximately 5 to 8 ft (see Figures 7.2-5 through 7.2-7). Groundwater elevations fall slowly during periods of low precipitation. The changes in groundwater elevation in response to precipitation are largely independent of variations in surface water elevation in the Green River because the river elevation is typically below the groundwater levels observed on the site (Figure 7.2-8).

Well data indicate that groundwater in the mitigation area is perched over a low-permeability clay layer and generally flows northwesterly in the same direction as surface water (Figure 7.2-9 through 7.2-11). A groundwater divide occurs approximately 700 ft west of the Green River (see Figure 7.2-9). East of this divide, groundwater flows eastward toward the river. West of the divide, water flows to the northwest.

### Soils

The soils on the mitigation site are alluvial in origin, developed from material deposited on the site by the Green River. The surficial layers of these soils are a complex of silty mineral soils, frequently with lenses of fine sand intermixed. Plowing has mixed the surficial layers of soil, typically to a depth of 9 to 10 inches.

The King County Soil Survey (Snyder et al. 1973) maps soils on the site as the poorly drained Briscot, and Oridia silt loams, and the somewhat poorly drained Renton silt loam (Figure 7.2-12; Table 7.2.5). Briscot, Oridia, and Renton silt loams are designated as hydric soils on the King County, Washington Hydric Soil List (NRCS 2000).<sup>46</sup>

**Table 7.2-5. Drainage characteristics of soils occurring on the mitigation site.**

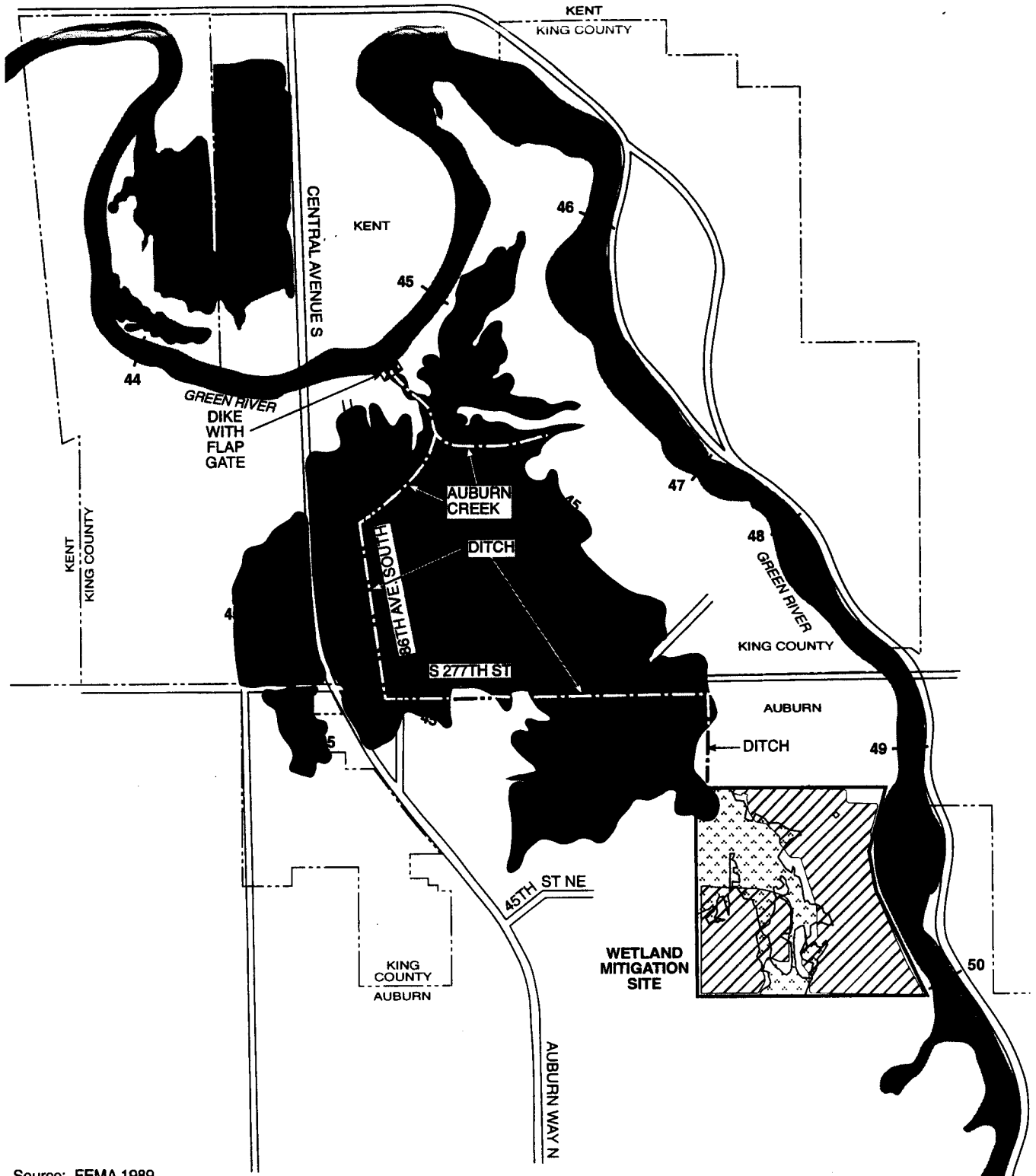
| Soil Series <sup>a</sup> | Drainage Class  | High Water Table                  |            |         | Flooding   |          |            |
|--------------------------|-----------------|-----------------------------------|------------|---------|------------|----------|------------|
|                          |                 | Permeability (in/hr) <sup>b</sup> | Depth (ft) | Months  | Frequency  | Duration | Months     |
| Briscot                  | Poorly          | 0.63-2.0                          | 1 to -1    | Nov-Apr | Occasional | Brief    | Dec to Feb |
| Oridia                   | Poorly          | 0.20-2.0                          | 1 to 3     | Nov-Apr | Occasional | Brief    | Nov to Apr |
| Renton                   | Somewhat poorly | 2.0-6.3                           | 1 to 1.5   | Nov-Apr | Common     | Brief    | Nov to Apr |

Source: USDA (1973).

<sup>a</sup> All soils are classified as hydric (wetland); however, evaluation of on-site conditions indicate non-hydric soil inclusions occur throughout the site.

<sup>b</sup> Within the top 20 inches of soil.

<sup>46</sup> Because the soils on the site are mapped as hydric, and farming activities including ditching have occurred, mitigation on the site could be considered restoration. Because the Port's mitigation establishes some wetland classes that probably did not historically occur on the site, the term "creation" is used for mitigation in upland portions of the site.



Source: FEMA 1989

Port of Seattle/Natural Resource Mitigation Plan/556-2912-001/01(03) 9/01 (K)



NOT TO SCALE



Existing Wetland



Excavation Area

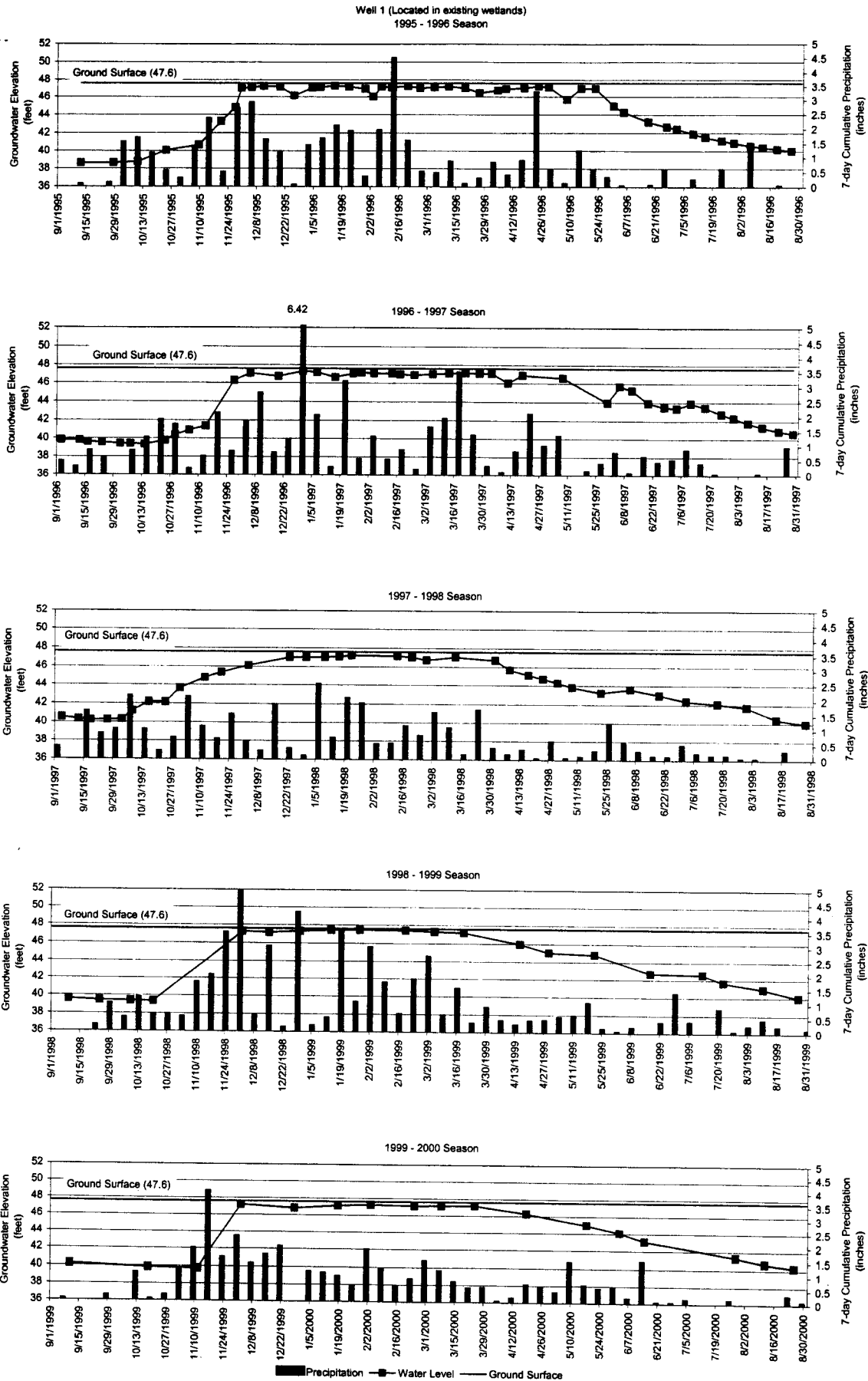


100-Year Floodplain

50

Flood Elevations

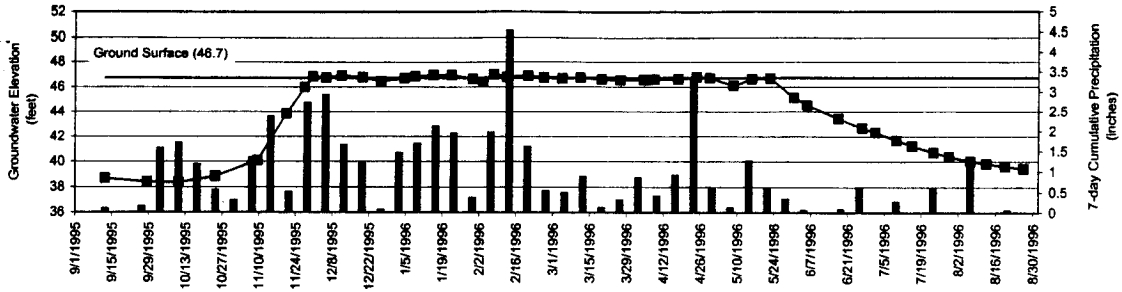
**Figure 7.2-4**  
**Location of the 100-Year**  
**Floodplain On and Near**  
**the Auburn Wetland**  
**Mitigation Site**



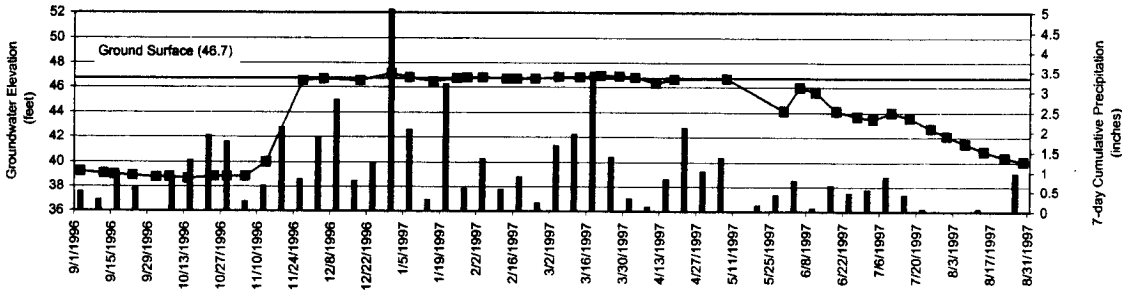
AR 049327

**Figure 7.2-5**  
Variations in Groundwater (Monitoring Well 1)  
and Precipitation

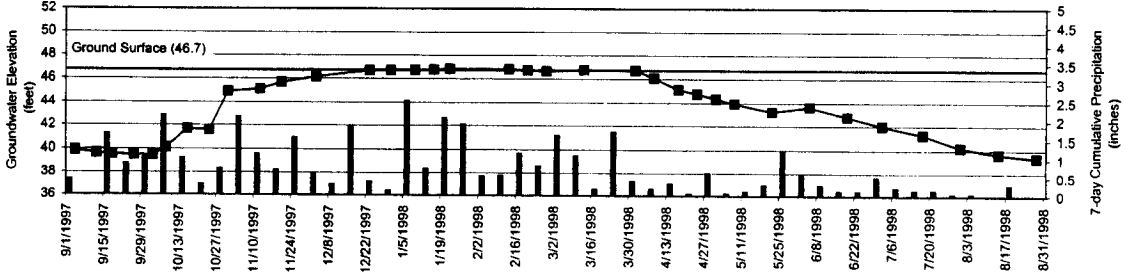
Well No. 3 (Located in existing wetlands)  
1995 - 1996 Season



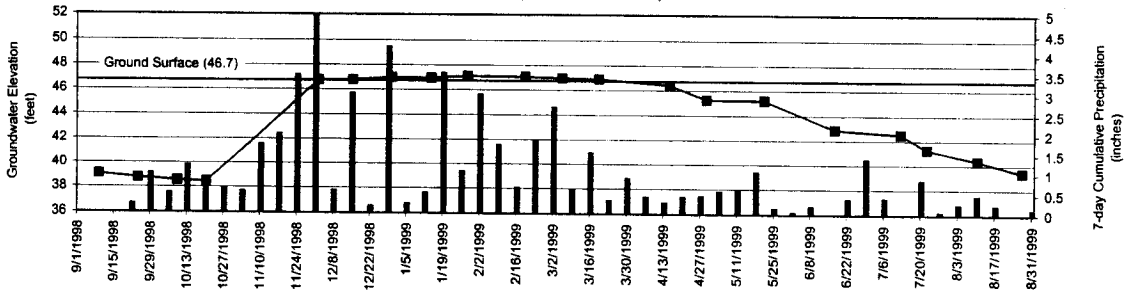
1996 - 1997 Season



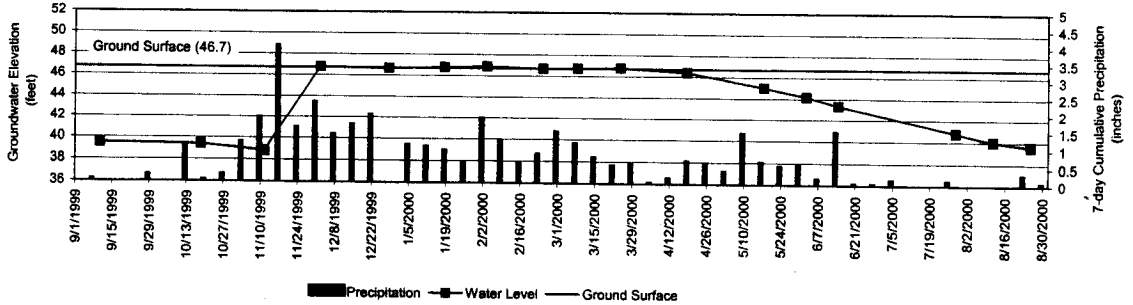
1997 - 1998 Season



1998 - 1999 Season



1999 - 2000 Season

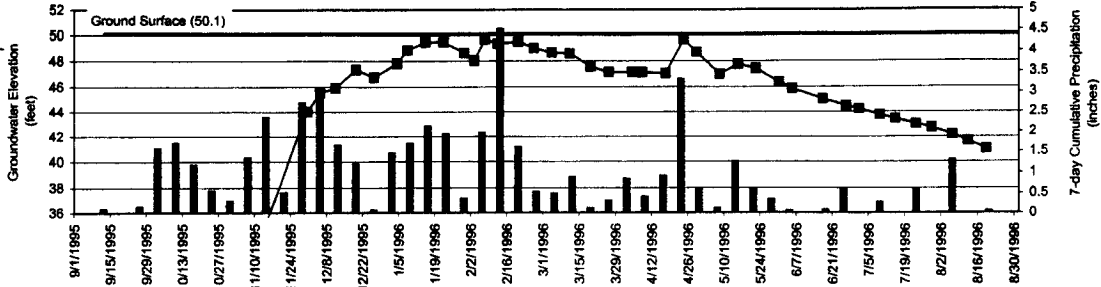


■ Precipitation — Water Level — Ground Surface

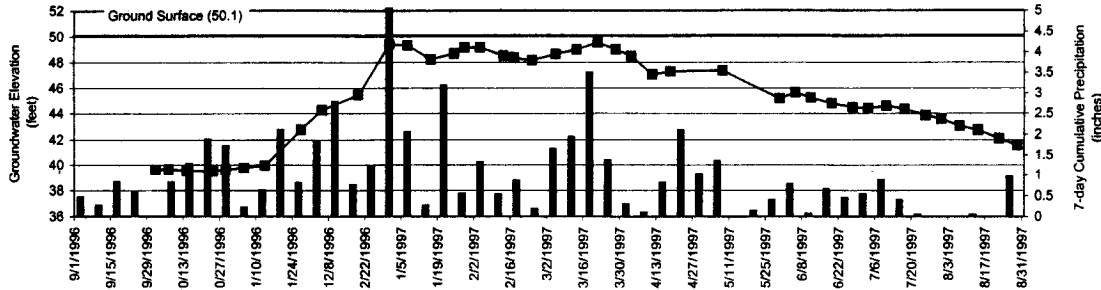
AR 049328

Figure 7.2-6  
Variations in Groundwater (Monitoring Well 3)  
and Precipitation

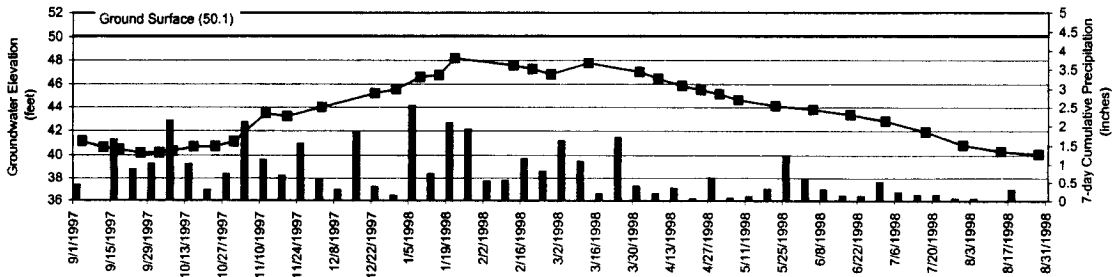
Well No. 5 (Located in existing upland)  
1995 - 1996 Season



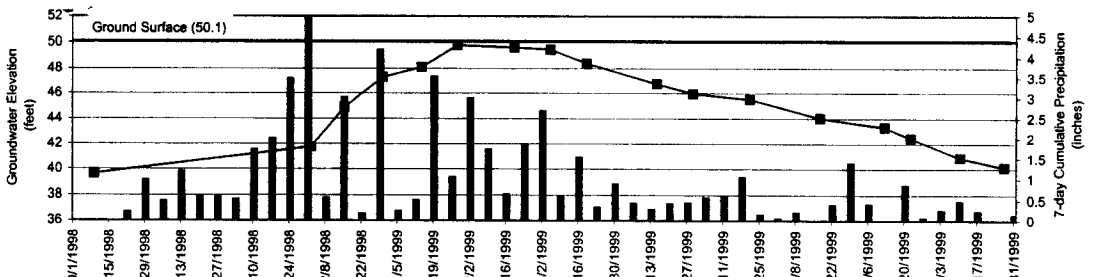
1996 - 1997 Season



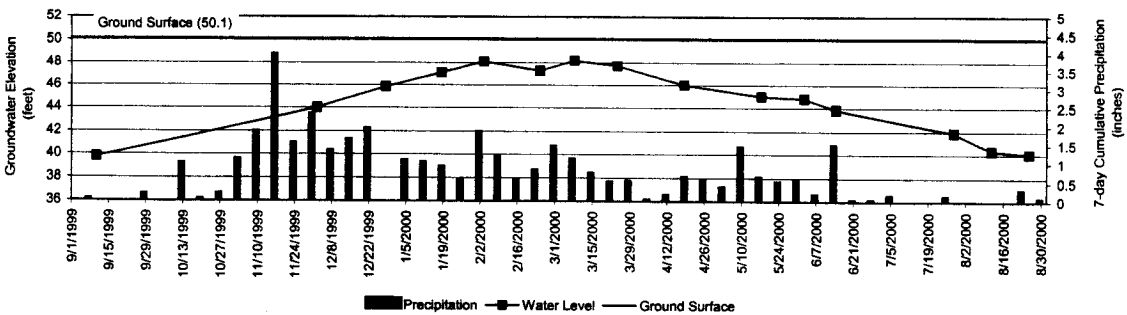
1997 - 1998 Season



1998 - 1999 Season



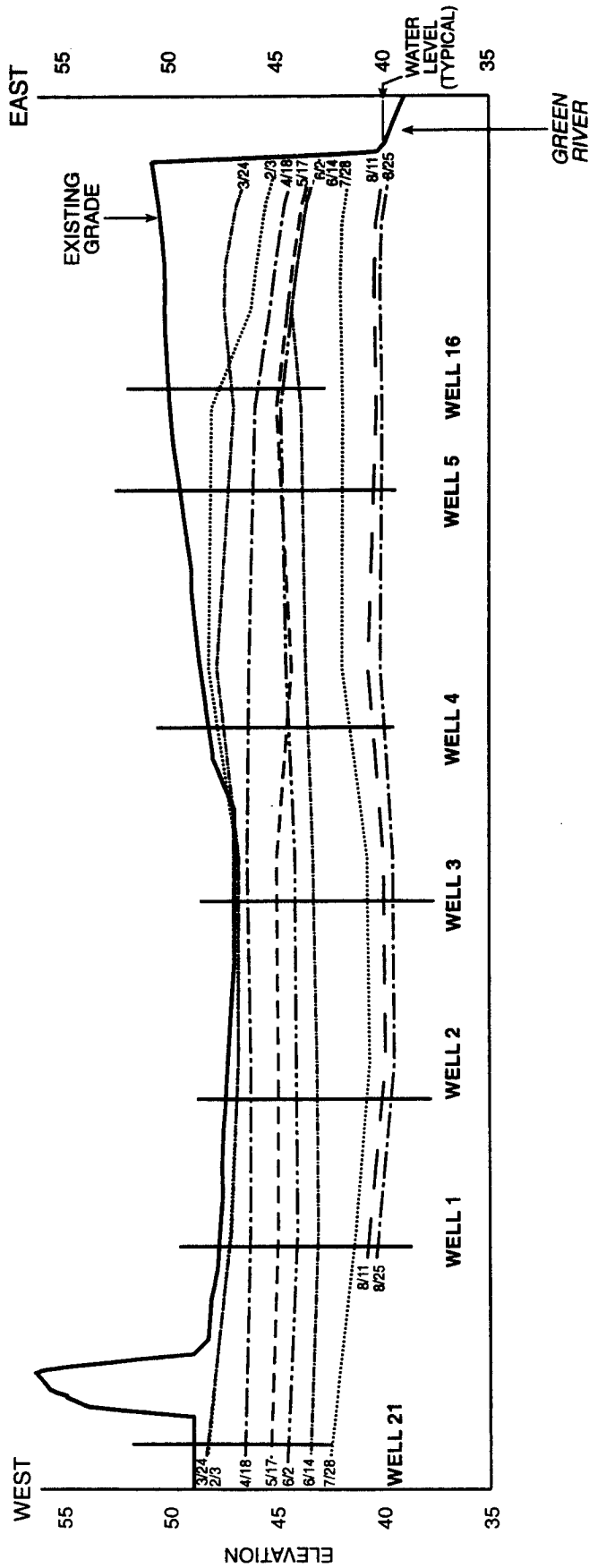
1999 - 2000 Season



■ Precipitation    - - - Water Level    — Ground Surface

AR 049329

Figure 7.2-7  
Variations in Groundwater (Monitoring Well 5)  
and Precipitation

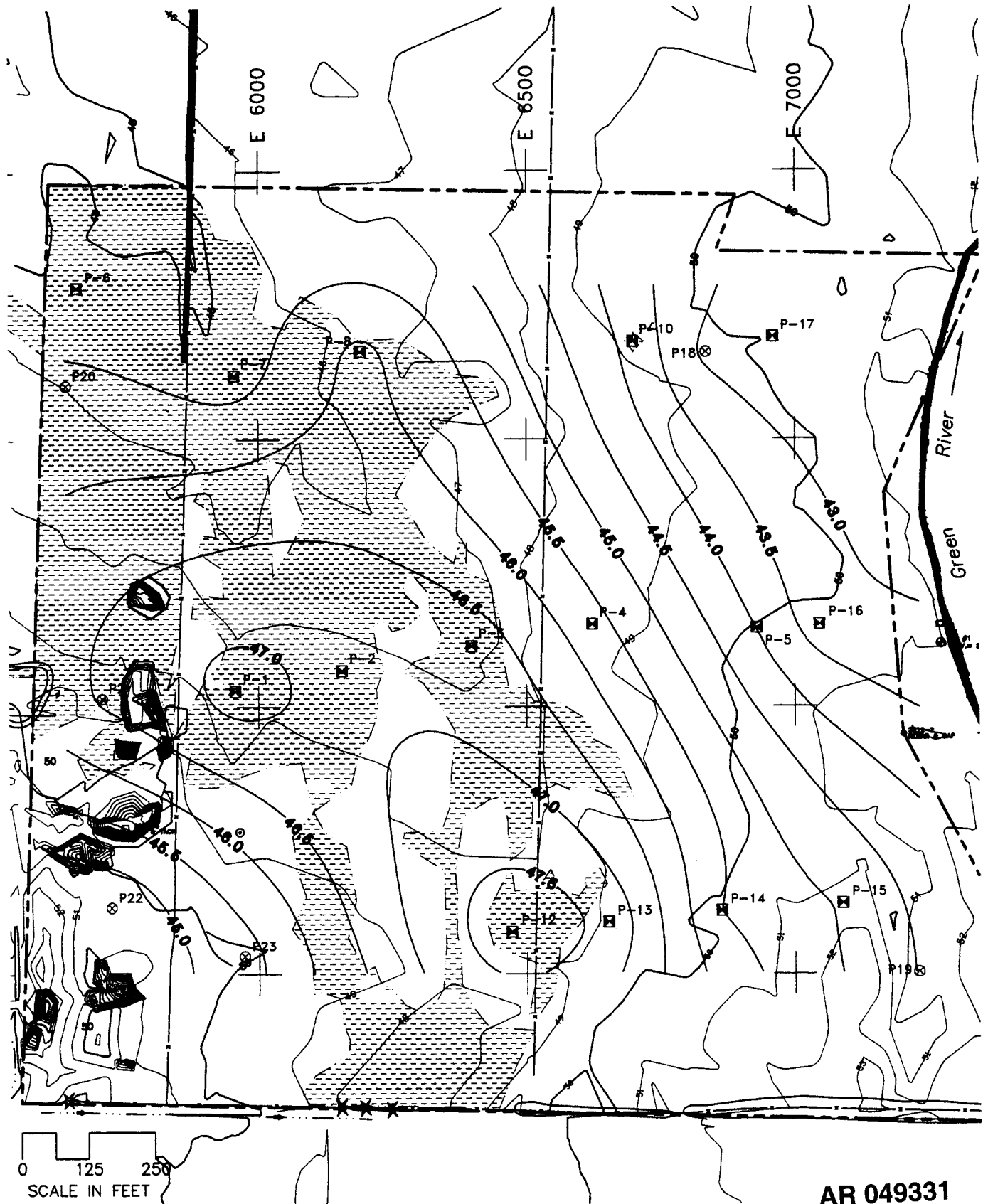


**Figure 7.2-8**  
**Cross Section of**  
**Groundwater Elevations**  
**(February-August 2000) at**  
**the Wetland Mitigation Site**

Port of Seattle/Natural Resource Mitigation Plan/556-2912-001/01(03) 6/01 (K)

- 2/3
- 3/24
- 4/18
- 5/17
- 6/2
- 8/14
- 7/28
- 8/11
- 8/25

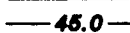
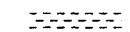
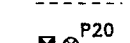

SCALE IN FEET  
 0 100 200  
 (HORIZONTAL)



AR 049331

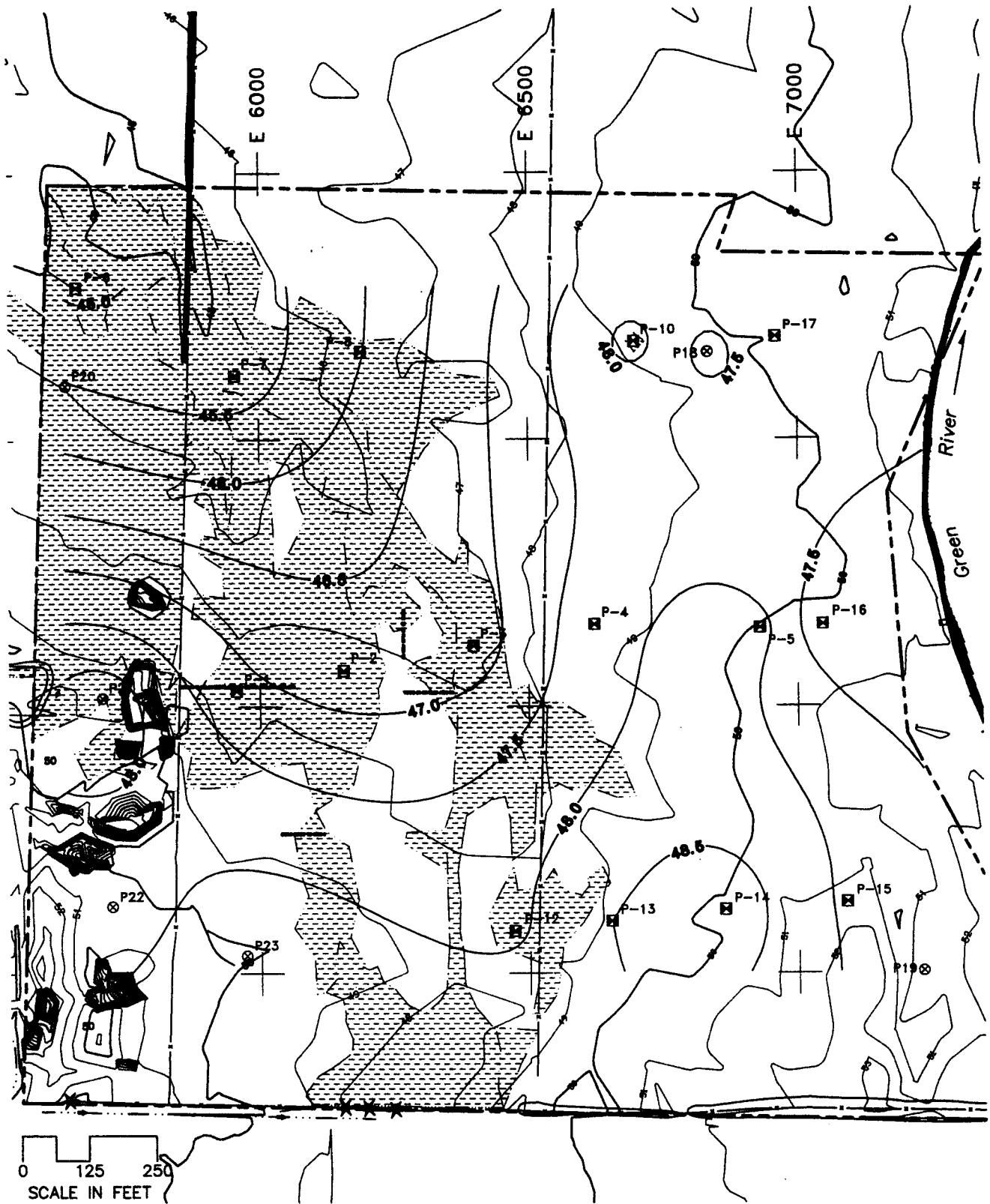
FILE: 29121404a  
DATE: 09/08/01

**LEGEND:**

-  Groundwater Contour and Elevation
-  Existing Wetland
-  Piezometer Locations and Number
-  Existing Ground Surface Contour and Elevation




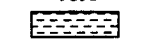
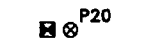
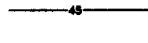
**Figure 7.2-9  
Groundwater Elevations on the  
Auburn Wetland Mitigation Site  
(December 2, 1999)**



FILE: 29121404b  
DATE: 09/06/01



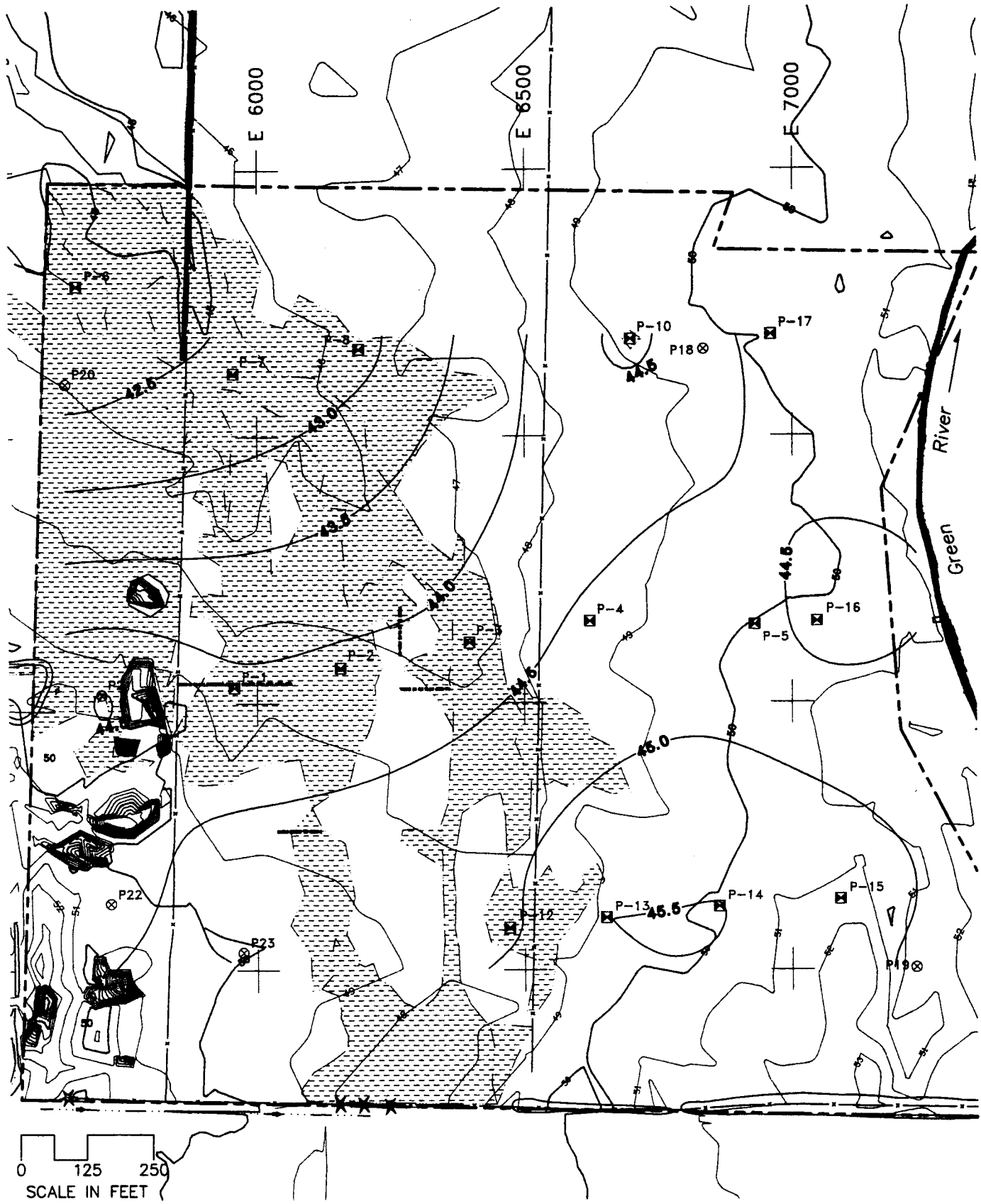
**LEGEND:**

-  Groundwater Contour and Elevation
-  Existing Wetland
-  Piezometer Locations and Number
-  Existing Ground Surface Contour and Elevation

**Figure 7.2-10**  
**Groundwater Elevations on the**  
**Auburn Wetland Mitigation Site**  
**(March 8, 2000)**

AR 049332





FILE: 29121404c  
DATE: 09/06/01

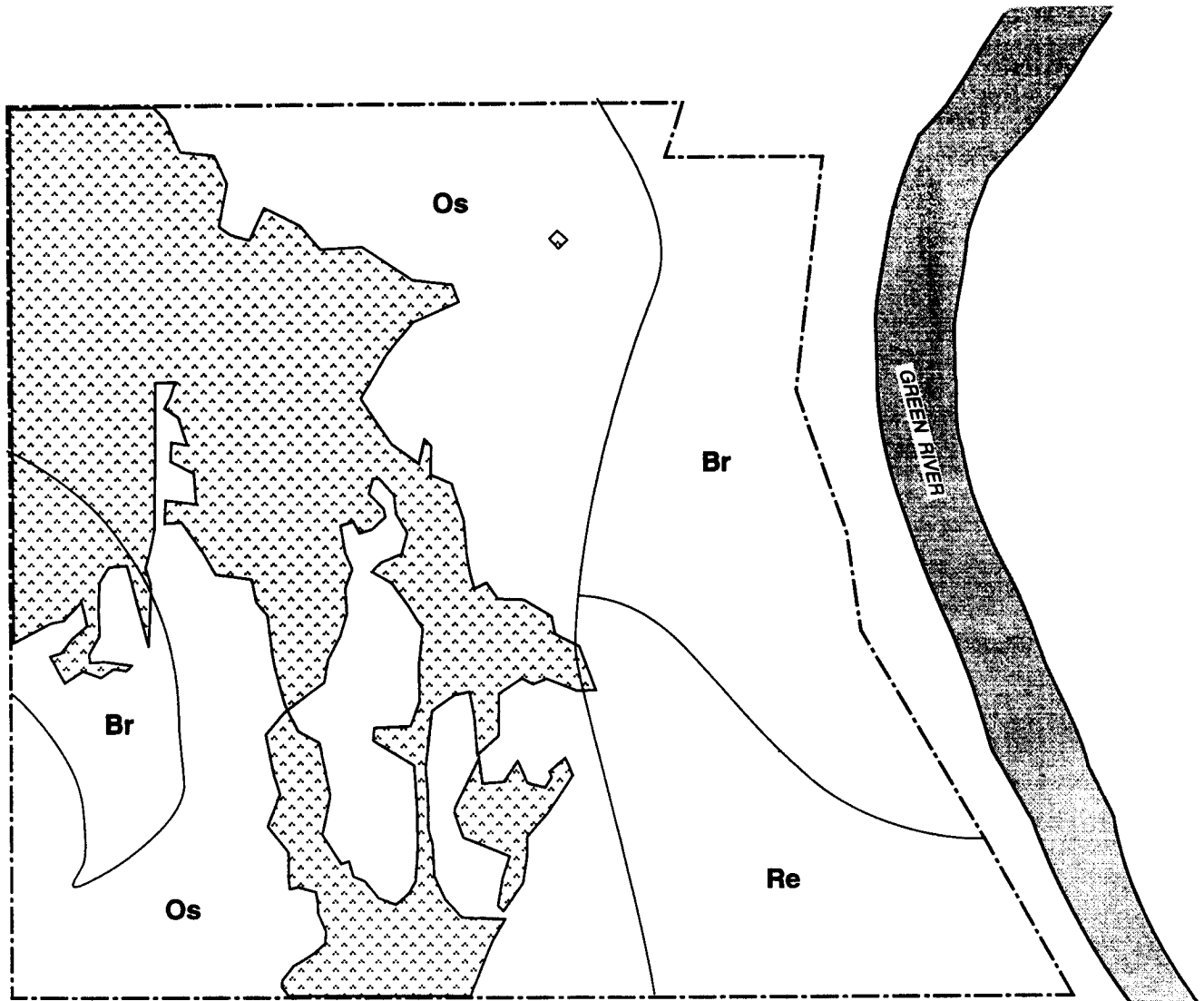
**LEGEND:**



- 44.5 — Groundwater Contour and Elevation
- Existing Wetland
- ⊠ P20 Piezometer Locations and Number
- 45 — Existing Ground Surface Contour and Elevation

**Figure 7.2-11  
Groundwater Elevations on the  
Auburn Wetland Mitigation Site  
(June 2, 2000)**

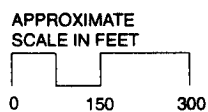
AR 049333





Source: USDA 1973

Port of Seattle/Natural Resource Mitigation Plan/556-2912-001/01(03) 6/01 (K)

AR 049334



- |           |                   |                                                                                     |                             |
|-----------|-------------------|-------------------------------------------------------------------------------------|-----------------------------|
| <b>Re</b> | Renton Silt Loam  |  | Existing Wetland            |
| <b>Os</b> | Oridia Silt Loam  |  | Site Boundary (Approximate) |
| <b>Br</b> | Briscot Silt Loam |                                                                                     |                             |

**Figure 7.2-12**  
**Soil Types on the**  
**Proposed Wetland**  
**Mitigation Site**

The published soil descriptions are generally consistent with the results of the laboratory and field analysis of soil performed by Parametrix in October 1995 and soil data collected in the fall of 2000 (Parametrix 2000b). Field observations and analytical test results indicate that two general soil profiles occur on the proposed mitigation site: a wetland soil profile and an upland soil profile (Figure 7.2-13).

The wetland soil profile generally consists of a 6-inch organic layer that covers a 72-inch layer of clayey silt (see Figure 7.2-13). The first 24 inches of the clayey silt are uniform, with mottles dispersed throughout. This uniformity is likely a result of past plowing. Below the uniformly mixed silt, the soil is stratified to layers of gray silt and sandy silt that grades to a sandy silt layer at a depth of about 72 inches. Below the sandy silt are 12 to 16 inches of very compact clayey silt. Below the clayey silt layer, the soil grades to a uniformly fine sand layer. The permeability of the clay silt varies between 0.001 to 0.003 inches/hour (determined at two locations). Because of the thickness of the clayey silt layer and the absence of an underlying fine sand (as found in the adjacent upland soils described below), these soils drain slowly, allowing hydric soil characteristics to develop.

In the upland portion of the site, including the areas outside the existing wetlands that would be graded under the proposed mitigation design, the upper 30 inches of soil is similar to the wetland soils described above (see Figure 7.2-13). A 6-inch topsoil layer is present over a 24-inch, uniformly mixed layer of clayey silt with dispersed mottles. Below 30 inches a 36- to 66-inch layer of uniform gray, fine sand (with some silt) is found. A 6- to 8-inch-thick clayey silt layer was encountered between the 72- and 96-inch depth. Below this clayey silt, the soil returns to a uniform fine sand. The sand layer located near the soil surface and a relatively thin clay silt layer in these soils allow them to drain more rapidly than the wetland soils.

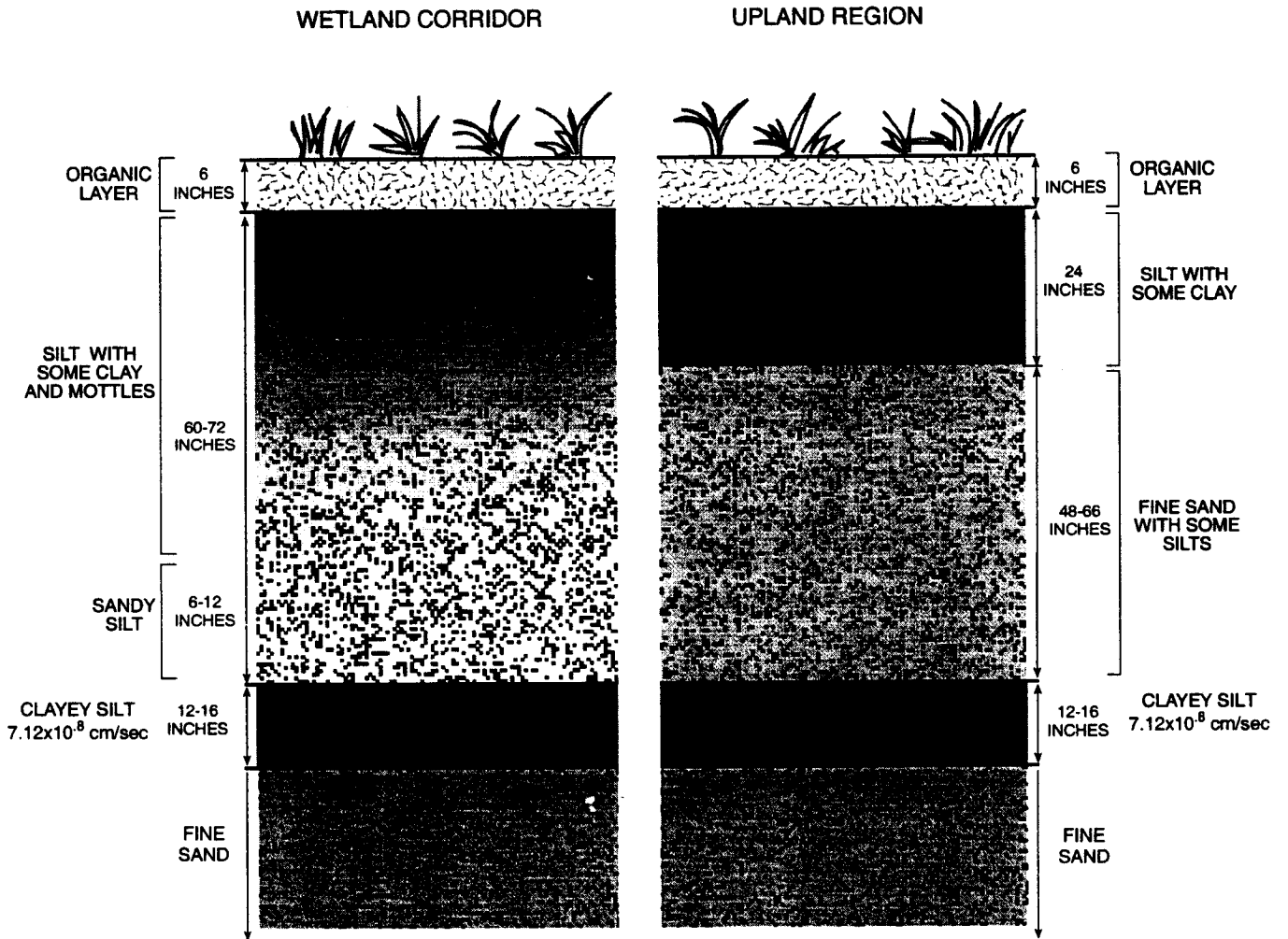
#### **7.2.5.2 Environmental Site Assessment**

A Phase I Site Assessment of the mitigation property was conducted in December 1995 (Parametrix 1995). The report was prepared according to guidelines described in *American Society for Testing and Materials (ASTM) Standard Practice for Environmental Site Assessments: Phase I Environmental Site Assessment Process* (ASTM E 1527). The assessment indicates no environmental conditions of concern associated with past or current use of the site and adjacent properties.

#### **7.2.5.3 Wildlife Habitat**

The mitigation site consists of abandoned agricultural land that is dominated by grasses and forbs. The properties immediately adjacent to the site to the north and south are actively farmed. West of the site, wildlife habitat has been largely eliminated by residential development. No permanent aquatic habitat is found on the site, although the Green River provides aquatic habitat near the eastern site boundary. Forest slopes along the east bank of the Green River provide habitat connectivity to riparian and other wetland systems, and forested areas. The WDFW Priority Habitats and Species database identifies the palustrine emergent wetland that bisects the site as a priority habitat (all wetlands are considered priority habitat by WDFW).

Habitat quality of the existing wetlands and the adjacent grassy uplands is relatively low due to a number of factors. The relatively uniform pasture grass vegetation is dominated by non-native plant species, lacks structural diversity, has low plant species diversity, and lacks habitat complexity.



POS Natural Resource Mitigation/556-2912-001/01(03) 12/00

Data Compiled by Parametrix

**Figure 7.2-13  
Typical Soil Profiles at  
the Wetland Mitigation Site**

**AR 049336**

Small mammals use the area for feeding and breeding. The site may provide foraging habitat for raptors, such as Northern harriers and red-tailed hawks. Apart from the tall pasture grasses there is a general lack of cover from predators, and a lack of habitat complexity (e.g., pits and mounds, LWD) that provides for breeding, resting, and/or thermal cover for small mammals. For most passerine bird species, the site lacks habitat structure for nesting, protection from predators, thermal cover, or perching. A narrow band of shrub vegetation along the southern boundary provides limited forage and perching habitat. Amphibian habitat on the site is currently limited by a lack of seasonally inundated pools, forest cover, and LWD.

Tracks or scat of coyote, mink, deer, and raccoon were observed on or near the mitigation site during the site assessment. Species observed on the site include kingfisher, short-eared owl, barn owl, common snipe, red-tailed hawk, common yellowthroat, and mallard duck. Most of these species appeared to be most abundant in the eastern portion of the site next to the Green River.

#### **7.2.5.4 Functional Changes Anticipated at the Auburn Mitigation Site**

The off-site wetland mitigation site is designed to replace wetland habitat functions affected by implementation of the proposed Master Plan Update improvements. The proposed design of the mitigation site will also provide additional mitigation for wildlife species using wetland buffer areas and other upland habitats at the airport. While about 20 acres of the mitigation site contains wetlands, the net result of the proposed mitigation is beneficial to these wetlands in that it restores them to a more natural condition, with higher habitat functions, as discussed below (see Table 4.1-2; also see Table 4-16 in Parametrix 2001b). There would be no adverse changes to the physical or biological functions provided by the existing wetlands on or near the site.

#### **Wildlife Habitat**

Construction of the forested, shrub, and emergent wetlands would create conditions that provide habitat for a variety of wildlife species (Table 7.2-6). Habitat structure and availability will change as vegetation matures over the next several decades, and the wildlife species using the site are expected to change over time (Table 7.2-7). Plant species proposed for the wetland mitigation area and their values to various forms of wildlife are presented in Table 7.2-8.

Post-construction habitat structure in forested wetlands would be similar to a regenerating forest, and would develop mature forest habitat attributes after several decades (Figure 7.2-14). The shrub understory would enhance development of habitat structure. Songbird use in early stages of habitat development would include foliage and bark-gleaning species (kinglet, chickadee, bushtit, and vireo) that forage in the area. In later years, Oregon ash, vine maple, willows, redcedar, and western hemlock seed production would be used by additional songbird species. Small mammals would likely forage on the forest floor for seeds and invertebrates, even though optimal habitat conditions would not occur for one or more decades. As a tree canopy begins to develop, it would provide nesting habitat and cover for predator avoidance.

Post-construction habitat structure in shrub wetlands would generally be similar to that of forested systems during the first several years of development (see Figure 7.2-14). However, since shrub communities would periodically be flooded, ground-dwelling animals would be less common. The shrub community would reach functional maturity in 15 to 25 years following planting (see Figure 7.2-14).

**Table 7.2-6. Wildlife species expected to occur in the Auburn wetland mitigation site after construction.**

| Common Name                | Habitat Type                         |                                     |               |                |                 | Abandoned Agricultural Land |
|----------------------------|--------------------------------------|-------------------------------------|---------------|----------------|-----------------|-----------------------------|
|                            | Permanently Flooded Emergent Wetland | Seasonally Flooded Emergent Wetland | Shrub Wetland | Forest Wetland | Riparian Forest |                             |
| <b>Amphibians</b>          |                                      |                                     |               |                |                 |                             |
| Northwestern salamander    | X                                    | X                                   |               | X              | X               |                             |
| Long-toed salamander       |                                      | X                                   | X             | X              | X               |                             |
| Pacific giant salamander   | X                                    |                                     |               | X              | X               |                             |
| Rough-skinned newt         | X                                    | X                                   |               |                | X               |                             |
| Ensatina                   |                                      |                                     |               |                | X               |                             |
| Western toad               | X                                    | X                                   |               |                |                 |                             |
| Pacific chorus frog        | X                                    | X                                   | X             | X              | X               |                             |
| Red-legged frog            | X                                    | X                                   | X             | X              | X               |                             |
| Bullfrog <sup>1</sup>      | X                                    |                                     |               |                |                 |                             |
| <b>Reptiles</b>            |                                      |                                     |               |                |                 |                             |
| Common garter snake        | X                                    | X                                   | X             | X              | X               |                             |
| <b>Birds</b>               |                                      |                                     |               |                |                 |                             |
| Great blue heron           | X                                    | X                                   | X             | X              |                 |                             |
| Canada goose               | X                                    | X                                   |               |                |                 | X                           |
| Green-winged teal          | X                                    | X                                   |               |                |                 | X                           |
| Mallard                    | X                                    | X                                   | X             |                |                 | X                           |
| Northern pintail           | X                                    | X                                   |               |                |                 | X                           |
| American pigeon            | X                                    | X                                   |               |                |                 | X                           |
| Osprey                     |                                      |                                     |               |                | X               |                             |
| Bald eagle                 |                                      |                                     |               |                | X               |                             |
| Northern harrier           | X                                    | X                                   |               |                |                 | X                           |
| Red-tailed hawk            |                                      |                                     |               | X              | X               | X                           |
| Killdeer                   | X                                    | X                                   |               |                |                 | X                           |
| Common snipe               | X                                    | X                                   |               |                |                 |                             |
| Herring gull               | X                                    |                                     |               |                |                 | X                           |
| Rock dove <sup>a</sup>     |                                      |                                     |               |                |                 | X                           |
| Western screech-owl        |                                      |                                     |               | X              | X               |                             |
| Rufous hummingbird         |                                      |                                     |               |                | X               | X                           |
| Belted kingfisher          | X                                    |                                     |               |                |                 |                             |
| Downy woodpecker           |                                      |                                     |               | X              | X               |                             |
| Northern flicker           |                                      |                                     |               | X              | X               |                             |
| Pileated woodpecker        |                                      |                                     |               | X              |                 |                             |
| Willow flycatcher          |                                      |                                     |               | X              | X               |                             |
| American/northwestern crow | X                                    | X                                   |               | X              | X               | X                           |
| Black-capped chickadee     |                                      |                                     |               | X              | X               |                             |
| Bushtit                    |                                      |                                     |               | X              | X               |                             |

Table 7.2-6. Wildlife species expected to occur in the Auburn wetland mitigation site after construction (continued).

| Common Name                    | Habitat Type                         |                                     |               |                |                 |                             |
|--------------------------------|--------------------------------------|-------------------------------------|---------------|----------------|-----------------|-----------------------------|
|                                | Permanently Flooded Emergent Wetland | Seasonally Flooded Emergent Wetland | Shrub Wetland | Forest Wetland | Riparian Forest | Abandoned Agricultural Land |
| Bewick's wren                  |                                      |                                     | X             | X              | X               |                             |
| Winter wren                    |                                      |                                     |               |                | X               |                             |
| Marsh wren                     | X                                    |                                     | X             |                |                 |                             |
| Golden-crowned kinglet         |                                      |                                     |               |                | X               |                             |
| Ruby-crowned kinglet           |                                      |                                     |               | X              | X               |                             |
| American robin                 |                                      | X                                   |               | X              | X               | X                           |
| Varied thrush                  |                                      |                                     |               | X              | X               |                             |
| European starling <sup>a</sup> |                                      |                                     |               | X              | X               | X                           |
| Yellow warbler                 |                                      |                                     |               | X              | X               |                             |
| Yellow-rumped warbler          |                                      |                                     |               | X              | X               |                             |
| MacGillivray's warbler         |                                      |                                     | X             | X              | X               |                             |
| Common yellowthroat            | X                                    |                                     | X             |                |                 |                             |
| Wilson's warbler               |                                      |                                     |               | X              | X               |                             |
| Rufous-sided towhee            |                                      |                                     |               | X              | X               |                             |
| Fox sparrow                    |                                      |                                     |               | X              | X               |                             |
| Song sparrow                   | X                                    | X                                   | X             | X              | X               | X                           |
| Dark-eyed junco                |                                      |                                     |               | X              | X               |                             |
| Red-winged blackbird           | X                                    | X                                   | X             |                |                 | X                           |
| Brown-headed cowbird           | X                                    | X                                   | X             | X              | X               | X                           |
| American goldfinch             |                                      |                                     |               | X              | X               |                             |
| House sparrow <sup>a</sup>     |                                      |                                     |               |                |                 | X                           |
| <b>Mammals</b>                 |                                      |                                     |               |                |                 |                             |
| Vagrant shrew                  |                                      | X                                   | X             | X              | X               |                             |
| Pacific water shrew            | X                                    | X                                   |               |                |                 |                             |
| Shrew-mole                     |                                      |                                     |               |                | X               |                             |
| Pacific mole                   |                                      |                                     |               |                |                 | X                           |
| Pacific jumping mouse          |                                      |                                     |               | X              | X               |                             |
| Raccoon                        | X                                    | X                                   | X             | X              | X               |                             |
| Mink                           | X                                    | X                                   | X             | X              | X               |                             |
| Striped skunk                  |                                      |                                     |               |                | X               | X                           |
| Coyote                         |                                      |                                     | X             | X              | X               |                             |
| Red fox                        |                                      |                                     | X             | X              | X               |                             |

<sup>a</sup> This is an introduced species.

Table 7.2-7. Potential wildlife use of constructed wetland habitats.

| Wildlife Types                  | Years After Planting |        |         |     |               |        |         |       |                |         |          |       |
|---------------------------------|----------------------|--------|---------|-----|---------------|--------|---------|-------|----------------|---------|----------|-------|
|                                 | Emergent Wetland     |        |         |     | Shrub Wetland |        |         |       | Forest Wetland |         |          |       |
|                                 | 0 to 2               | 2 to 5 | 5 to 15 | >15 | 0 to 2        | 2 to 5 | 5 to 15 | >15   | 0 to 2         | 2 to 10 | 10 to 25 | >25   |
| <b>Mammals</b>                  |                      |        |         |     |               |        |         |       |                |         |          |       |
| Shrews and mice                 | F                    | F      | F       | F   | F             | B/F    | B/F     | B/F   | F              | B/F     | B/F      | B/F   |
| Squirrels                       |                      |        |         |     |               | F      | F       | F     | F              | F       | B/F      | B/F   |
| Raccoons and mink               |                      |        |         |     |               | F      | F       | F     |                | F       | B/F      | F/M   |
| Fox and coyote                  |                      |        |         |     |               | F      | F       | F     |                | F       | F        | F     |
| Bats                            | F                    | F      | F       | F   | F             | F      | F       | F     |                | F       | F        | F     |
| Deer                            | F                    | F      | F       | F   | F             | F      | F       | F     | F              | F       | F        | F     |
| <b>Birds</b>                    |                      |        |         |     |               |        |         |       |                |         |          |       |
| Shrub-nesting songbirds         | F                    | F      | F/M     | F/M | F/M           | F/M    | B/F/M   | B/F/M | F/M            | B/F/M   | B/F/M    | B/F/M |
| Swallows and swifts             | F                    | F      | F       | F   | F             | F      | F       | F     | F              | F       | F        | B/F   |
| Forest-dwelling songbirds       |                      |        |         |     |               | F/M    | F/M     | F/M   | F/M            | F/M     | B/F/M    | B/F/M |
| Cavity-nesting birds            |                      |        |         |     |               | F      | F       | F     | F              | F       | F        | B/F   |
| Marsh-nesting songbirds         | F                    | F      | B/F     | B/F | F             | F      | B/F     | B/F   | F              | F       | F        | B/F   |
| Raptors                         | F                    | F      | F       | F   | F             | F      | F       | F     | F              | F       | F        | B/F   |
| Wading birds                    |                      |        |         |     |               | F/M    | F/M     | F/M   | F/M            | F/M     |          |       |
| Dabbling waterfowl              |                      |        |         |     |               | F/M    | F/M     | F/M   | F/M            | F/M     |          |       |
| Diving waterfowl                |                      |        |         |     |               | F/M    | F/M     | F/M   | F/M            | F/M     |          |       |
| <b>Herpetofauna</b>             |                      |        |         |     |               |        |         |       |                |         |          |       |
| Reptiles                        |                      |        |         |     |               | F      | F       | F     | F              | F       | B/F      | F     |
| Terrestrial-breeding amphibians |                      |        |         |     |               | F      | F       | F     | F              | F       | B/F      | B/F   |
| Aquatic-breeding amphibians     |                      |        |         |     |               | F      | B/F     | B/F   | F              | F       | F        | F     |
| <b>Macroinvertebrates</b>       |                      |        |         |     |               |        |         |       |                |         |          |       |
| Aquatic insects                 | B/F                  | B/F    | B/F     | B/F | B/F           | B/F    | B/F     | B/F   | B/F            | B/F     | B/F      | B/F   |
| Gastropods                      |                      |        |         |     |               |        |         |       |                |         |          |       |

B = Breeding  
 F = Foraging  
 M = Migration



Table 7.2-8. Plant species to be planted at the Auburn wetland mitigation site.

| Scientific Name            | Plant Species     |                   | Description                                                                                                                                                                                                                                                                                                                                                                                                                                                                                                                                                                                                                                                                                                                                                                                                                                                                                                                                                                                                                    |
|----------------------------|-------------------|-------------------|--------------------------------------------------------------------------------------------------------------------------------------------------------------------------------------------------------------------------------------------------------------------------------------------------------------------------------------------------------------------------------------------------------------------------------------------------------------------------------------------------------------------------------------------------------------------------------------------------------------------------------------------------------------------------------------------------------------------------------------------------------------------------------------------------------------------------------------------------------------------------------------------------------------------------------------------------------------------------------------------------------------------------------|
|                            | Common Name       | Wildlife Function |                                                                                                                                                                                                                                                                                                                                                                                                                                                                                                                                                                                                                                                                                                                                                                                                                                                                                                                                                                                                                                |
| <b>Deciduous Trees</b>     |                   |                   |                                                                                                                                                                                                                                                                                                                                                                                                                                                                                                                                                                                                                                                                                                                                                                                                                                                                                                                                                                                                                                |
| <i>Acer macrophyllum</i>   | Big-leaf maple    | Forage            | The seeds of big-leaf maple and Oregon ash are eaten by small mammals, songbirds, and game birds.* Cascara and western crabapple fruit are persistent and offer good winter forage for pileated woodpeckers, thrushes, band-tailed pigeons, and other songbirds. The female catkins of alder, cottonwoods, and willows are used by foraging songbirds. New growth provides browse for medium and large mammals. Deciduous trees provide foraging habitat for hawking and foliage-gleaning insectivores. The leaf litter provides food for detritivores (which in turn are consumed by small mammals, amphibians, reptiles, and birds).<br><br>Deciduous trees provide nesting habitat for birds, small mammals, and invertebrates; perching and roosting habitat for birds; and escape cover for prey species. Mature Oregon ash are vulnerable to heart rot and subsequent insect invasion, providing cavity nesting and roosting habitat. Leaf litter from deciduous trees is used as cover by amphibians and small mammals. |
| <i>Alnus rubra</i>         | Red alder         |                   |                                                                                                                                                                                                                                                                                                                                                                                                                                                                                                                                                                                                                                                                                                                                                                                                                                                                                                                                                                                                                                |
| <i>Populus trichocarpa</i> | Black cottonwood  |                   |                                                                                                                                                                                                                                                                                                                                                                                                                                                                                                                                                                                                                                                                                                                                                                                                                                                                                                                                                                                                                                |
| <i>Rhamnus purshiana</i>   | Cascara           |                   |                                                                                                                                                                                                                                                                                                                                                                                                                                                                                                                                                                                                                                                                                                                                                                                                                                                                                                                                                                                                                                |
| <i>Fraxinus latifolia</i>  | Oregon ash        |                   |                                                                                                                                                                                                                                                                                                                                                                                                                                                                                                                                                                                                                                                                                                                                                                                                                                                                                                                                                                                                                                |
| <i>Malus fusca</i>         | Pacific crabapple |                   |                                                                                                                                                                                                                                                                                                                                                                                                                                                                                                                                                                                                                                                                                                                                                                                                                                                                                                                                                                                                                                |
| <i>Salix lasianдра</i>     | Pacific willow    |                   |                                                                                                                                                                                                                                                                                                                                                                                                                                                                                                                                                                                                                                                                                                                                                                                                                                                                                                                                                                                                                                |
| <b>Coniferous Trees</b>    |                   |                   |                                                                                                                                                                                                                                                                                                                                                                                                                                                                                                                                                                                                                                                                                                                                                                                                                                                                                                                                                                                                                                |
| <i>Picea sitchensis</i>    | Sitka spruce      | Forage            | These coniferous trees provide seed forage for songbirds, game birds, mice, squirrels, voles, and shrews, as well as foraging habitat for hawking and foliage-gleaning insectivores. Deer, rabbit, and mountain beaver browse on new growth and young bark.<br><br>Evergreen vegetation provides breeding and roosting habitat for birds and small mammals. Coniferous heartwood often decays readily when attacked by fungi, resulting in hollow living trees that provide habitat for cavity-nesting and roosting species. The foliage provides year-round escape cover and thermal protection when deciduous foliage is lacking.                                                                                                                                                                                                                                                                                                                                                                                            |
| <i>Thuja plicata</i>       | Western redcedar  |                   |                                                                                                                                                                                                                                                                                                                                                                                                                                                                                                                                                                                                                                                                                                                                                                                                                                                                                                                                                                                                                                |
| <i>Abies grandis</i>       | Grand fir         | Habitat           |                                                                                                                                                                                                                                                                                                                                                                                                                                                                                                                                                                                                                                                                                                                                                                                                                                                                                                                                                                                                                                |

Table 7.2-8. Plant species proposed for the Auburn wetland mitigation area (continued).

| Scientific Name              | Plant Species         |                   | Description                                                                                                                                                                                                                                                                                                                                                                                                                                                                                                                                                  |
|------------------------------|-----------------------|-------------------|--------------------------------------------------------------------------------------------------------------------------------------------------------------------------------------------------------------------------------------------------------------------------------------------------------------------------------------------------------------------------------------------------------------------------------------------------------------------------------------------------------------------------------------------------------------|
|                              | Common Name           | Wildlife Function |                                                                                                                                                                                                                                                                                                                                                                                                                                                                                                                                                              |
| <b>Shrubs</b>                |                       |                   |                                                                                                                                                                                                                                                                                                                                                                                                                                                                                                                                                              |
| <i>Salix stichensis</i>      | Sitka willow          | Forage            | Willow shrubs may be used as browse by deer and some small mammals. The female catkins provide forage for songbirds. Vine maple seeds are eaten by small birds and mammals.                                                                                                                                                                                                                                                                                                                                                                                  |
| <i>Salix hookeriana</i>      | Hooker's willow       |                   |                                                                                                                                                                                                                                                                                                                                                                                                                                                                                                                                                              |
| <i>Salix scouleriana</i>     | Scouler's willow      |                   |                                                                                                                                                                                                                                                                                                                                                                                                                                                                                                                                                              |
| <i>Acer circinatum</i>       | Vine maple            | Habitat           | These shrubs provide dense multi-stem nesting habitat and escape cover for songbirds and small mammals. The leaf litter provides habitat for amphibians and detritivores.                                                                                                                                                                                                                                                                                                                                                                                    |
| <b>Herbaceous Species</b>    |                       |                   |                                                                                                                                                                                                                                                                                                                                                                                                                                                                                                                                                              |
| <i>Cornus stolonifera</i>    | Red-osier dogwood     | Forage            | Hazelnut provides a mast crop and winter forage for game birds, deer, and small mammals. Twinberry, red elderberry, snowberry, and Indian plum fruit are an excellent food source for birds and mammals. Rose hips are a food source for songbirds, game birds, deer, small mammals, and rodents. The fruits are persistent and provide forage in the winter months. Salmonberries provide food for songbirds, game birds, small mammals, deer, and some omnivores (fox, raccoon, etc.). Deer browse on the leaves, twigs, and fruit of all of these shrubs. |
| <i>Lonicera involucrata</i>  | Twinberry             |                   |                                                                                                                                                                                                                                                                                                                                                                                                                                                                                                                                                              |
| <i>Oemleria cerasiformis</i> | Indian plum           |                   |                                                                                                                                                                                                                                                                                                                                                                                                                                                                                                                                                              |
| <i>Physocarpus capitatus</i> | Pacific ninebark      |                   |                                                                                                                                                                                                                                                                                                                                                                                                                                                                                                                                                              |
| <i>Rubus spectabilis</i>     | Salmonberry           |                   |                                                                                                                                                                                                                                                                                                                                                                                                                                                                                                                                                              |
| <i>Rosa nutkana</i>          | Nootka rose           | Habitat           | The shrub structure provides nesting and escape cover for birds, mammals, and other prey species.                                                                                                                                                                                                                                                                                                                                                                                                                                                            |
| <b>Herbaceous Species</b>    |                       |                   |                                                                                                                                                                                                                                                                                                                                                                                                                                                                                                                                                              |
| <i>Carex rostrata</i>        | Beaked sedge          | Forage            | The seeds of sedges and fruits of rushes are eaten by songbirds, game birds, and waterfowl, especially mallard and ring-necked ducks. Deer and small mammals browse upon the foliage. Bur-reed fruit and the young shoots of most emergent plants are forage for waterfowl and muskrat.                                                                                                                                                                                                                                                                      |
| <i>Eleocharis palustris</i>  | Common spike-rush     |                   |                                                                                                                                                                                                                                                                                                                                                                                                                                                                                                                                                              |
| <i>Scirpus microcarpus</i>   | Small-fruited bulrush |                   |                                                                                                                                                                                                                                                                                                                                                                                                                                                                                                                                                              |
| <i>Scirpus acutus</i>        | Bulrush               |                   |                                                                                                                                                                                                                                                                                                                                                                                                                                                                                                                                                              |
| <i>Scirpus lacustris</i>     | Hardstem bulrush      |                   |                                                                                                                                                                                                                                                                                                                                                                                                                                                                                                                                                              |
| <i>Sparganium emersum</i>    | Narrow-leaf bur-reed  |                   |                                                                                                                                                                                                                                                                                                                                                                                                                                                                                                                                                              |

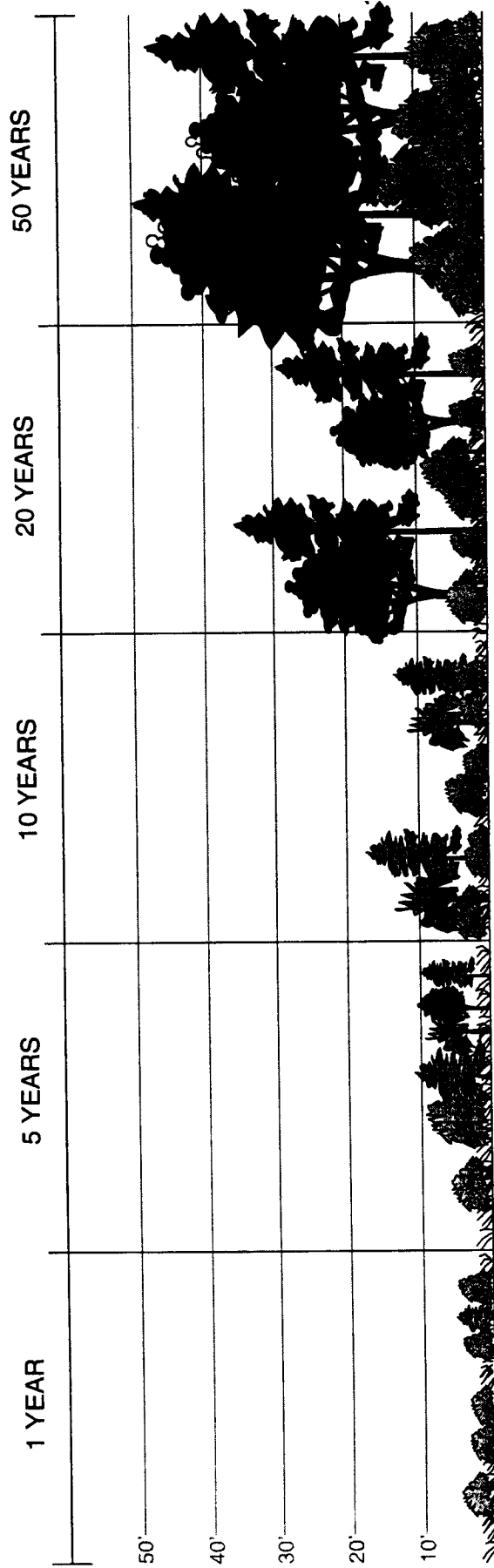
Table 7.2-8. Plant species proposed for the Auburn wetland mitigation area (continued).

| Scientific Name            | Plant Species   |                   | Description                                                                                                                                                                                                                                                                                             |
|----------------------------|-----------------|-------------------|---------------------------------------------------------------------------------------------------------------------------------------------------------------------------------------------------------------------------------------------------------------------------------------------------------|
|                            | Common Name     | Wildlife Function |                                                                                                                                                                                                                                                                                                         |
| <i>Oenanthe sarmentosa</i> | Water parsley   | Habitat           | These species provide nesting materials and cover for songbirds, waterfowl, and small mammals. Shrews, mice, and voles use the ground cover for thermal protection and predator avoidance. In late winter and spring floods, the stems are used for breeding substrate by amphibians and invertebrates. |
| <i>Polygonum amphibium</i> | Water smartweed | Forage            |                                                                                                                                                                                                                                                                                                         |
| <b>Grasses</b>             |                 |                   |                                                                                                                                                                                                                                                                                                         |
| <i>Agrostis alba</i>       | Redtop          | Forage            | Songbirds and rodents feed on all these grass seeds, while manna grass and red fescue are grazed by waterfowl.                                                                                                                                                                                          |
| <i>Festuca rubra</i>       | Red fescue      |                   |                                                                                                                                                                                                                                                                                                         |
| <i>Glyceria</i> sp.        | Manna grass     | Habitat           |                                                                                                                                                                                                                                                                                                         |
|                            |                 |                   | Grasses provide breeding and escape cover for small mammals. Grasses are used by many species for nest construction and lining.                                                                                                                                                                         |

Sources: Martin et al. (1951); Brown (1961); Payne and Bryant (1992)

\* Seed production by trees varies with maturity. Red alder and black cottonwood produce seeds at 4 to 10 years of age. Big-leaf maple, Douglas fir, and western redcedar produce seeds after 10 to 12 years of age. Oregon ash, Sitka spruce, and western hemlock produce large seed crops after about 20 years of growth.

**YEARS FOLLOWING PLANTING**



Low Structural Diversity —————> High Structural Diversity

Port of Seattle/Natural Resource Mitigation Plan/556-2912-001/01(03) 12/00 (K)

**Figure 7.2-14  
Typical Successional Changes  
in Forested Wetland Vegetation  
Following Planting**

Emergent communities would provide resting and foraging habitat for shore and water birds within 1 year of planting. After 2 to 3 years, most of the intended wildlife functions should be present, and in the following 5 to 10 years, relatively mature communities should be present.

Tree-nesting songbirds (such as thrushes, vireos, and warblers) are expected to use horizontal branches for nesting when the canopy closes enough to provide cover. Leaf litter and forest detritus would begin to accumulate, providing habitat for the invertebrates (Pennak 1989) that amphibians (such as ensatina), small mammals, and ground foraging birds feed on. Small mammals, in turn, are likely to become food for predators, such as barred owls. Over several decades, disease or competition for light would result in mortality. Dead and decaying trees would provide woody debris and snag habitat for flickers, woodpeckers, and small cavity-nesting birds.

The shrub and emergent wetlands should achieve stable habitat conditions earlier than the forested wetland community. Shrub wetland communities should produce forage and nesting opportunities within 2 to 10 years. Swainson's thrush and Wilson's warblers use moist shrub habitats for nesting and foraging. Berries produced by salmonberry, red elderberry, and red-osier dogwood are used by several insectivorous songbird species to supplement fall and winter diets (Ehrlich et al. 1988). Mink, shrews, and other small mammals would exploit these insect and aquatic invertebrate food sources. Wading birds, such as great blue herons and bitterns, can feed on small mammals and amphibians.

Amphibian use, however, would likely be limited by immigration rates because of the lack of existing amphibian habitat in the area. Some species, such as Pacific giant salamander, northwestern salamander, and rough-skinned newt, commonly migrate through terrestrial habitats and could use the mitigation site.

Although flooded emergent wetlands can provide substantial forage opportunities for ducks, habitat use would vary with proximity to upland predator cover. Waterfowl, which are wary of dense shrubs (which allow predators to approach undetected), prefer interspersed flooded emergent vegetation and open water. Slough sedge (*Carex obnupta*), spike-rush (*Eleocharus palustris*), and horsetail are all species preferred by dabbling ducks and geese during migration (Payne and Bryant 1992). Narrow-leaf bur-reed (*Sparganium emersum*) is preferred by dabblers and migrating wood ducks. As decaying vegetation builds up in flooded areas, shovelers, pintails, and other diving species could forage on growing populations of plankton, algae, aquatic insects, and snails.

Over time, portions of properties adjacent to or near the mitigation site may be developed for commercial and/or residential uses. Depending on the nature of any development and its proximity to the mitigation site, some changes to the wildlife habitat functions provided by the mitigation site may occur. The 65-acre mitigation site is large enough to provide key habitat functions for target wildlife species. The proximity of the mitigation site to riparian habitat corridors along the Green River will ensure that the project is connected to other terrestrial and aquatic habitats.

If significant areas of farmland near the mitigation site are developed, use of the mitigation area by non-water dependent wildlife (i.e., mammals such as deer, coyote, and red fox) may decrease because these species may be eliminated from adjacent areas. Development of nearby land with residential uses may increase use of the site by dogs and cats. Dogs and cats could affect some

wildlife populations on the mitigation site (i.e., ground-nesting birds and small mammals could be subject to increased predation or cats could become a food resource for coyote). Depending on the exact proximity of development to the wetland buffer and the intensity of human use, wildlife use of the buffer could be reduced. Alternatively, wetland protection and restoration on nearby parcels that contain wetlands (likely required by existing regulations) could result in increased habitat for wildlife and enhanced wildlife function of the mitigation site.

### **Hydrology**

Hydrologic conditions and functions at the wetland mitigation site are anticipated to be stable over the long term, even if future development occurs nearby. Hydrologic monitoring on the wetland mitigation site has been ongoing since September of 1995. The monitoring indicates that favorable subsurface hydrology necessary for creating wetlands exists, and the probability of successful wetland mitigation is high. Further, in planning the mitigation project, contingency actions were identified that will be implemented if post-construction monitoring indicates that performance standards for the wetland are not achieved.

Monitoring results indicate that seasonally high groundwater levels on the site are maintained by precipitation. This conclusion is based on observations of rapid increases in groundwater during mid to late fall, often within several days of heavy rainfall. The rates of water level increase are more rapid than one would expect if the high water table were dependent on groundwater movement from off-site areas. Because the site hydrology is largely precipitation driven, off-site development that may occur near the mitigation would have minimal effect on the hydrology in the mitigation wetlands.

Finally, stormwater management (water quality and discharge) standards and/or wetland protection and restoration requirements for development on nearby parcels will protect the hydrology of the site. These standards are likely to prioritize infiltration, and require water quality BMPs and detention to prevent high flow discharges. Wetland protection requirements (required by existing regulations) could result in wetland restoration and further protect hydrologic conditions on the Port's mitigation site.

### **7.3 MITIGATION SITE DESIGN**

The mitigation design is based on design objectives and criteria explained in this section. This section also explains the basis for specific design elements, including the rationale for establishing the wetland mitigation hydrologic water regime, grading plan, and planting plan.

The mitigation design for the site consists of the following elements:

- (1) Excavating two new wetland basins;
- (2) Establishing native forested, shrub, emergent, and open-water wetland habitats in these basins;
- (3) Enhancing the existing emergent wetlands by replacing the non-native plant communities with native forest and shrub communities;

- (4) Establishing a forested buffer around the perimeter of the site; and
- (5) Post-construction monitoring, adaptive management, and maintenance of the site.

**7.3.1 Water Regime**

An adequate water regime is the most critical factor in establishing the desired forest, shrub, and emergent wetland vegetation on the mitigation site. The duration and amount of standing water and soil saturation control the wetland classes and plant community types suitable for the site. Evaluation of the hydrology requirements of natural Puget Sound wetland communities (Ecology 1994a; Kunze 1994) and examination of over 5 years of groundwater monitoring data (see Figures 7.2-5, 7.2-6, and 7.2-7) indicate that it is feasible to create the hydrologic conditions necessary to sustain the diverse wetland habitats and plant communities designed for this site.

In the fall of 2000, ACOE evaluated wetland conditions on the mitigation site (Parametrix 2000b) and found additional wetlands, particularly on the west side of the mitigation site. The mitigation design presented in this document reflects the most current understanding of existing wetlands and groundwater hydrology on the site.

Excavating the two basins on the mitigation site to intercept the seasonally high or permanent groundwater table<sup>48</sup> will attain appropriate hydrologic conditions for a variety of native wetland plant communities by providing a range of soil saturation flooding conditions that will support a variety of plants.

Following grading, ground surface elevations on the site will range from approximately 37 to 50 ft, with most of the east basin below approximately 43 ft. Excavation in limited areas will be a maximum of 12 ft deep to create open-water habitat. The approximate elevations, hydrologic regime, and wetland vegetation classes proposed for the mitigation are presented in Table 7.3-1. The relationship of the proposed wetland vegetation zones to anticipated water levels and site topography of the east basin is shown in Figure 7.3-1.

**Table 7.3-1. Proposed wetland classes, elevation ranges, and hydrologic regimes.**

| <b>Proposed Wetland Class</b> | <b>Proposed Elevation Range (ft)</b>         | <b>Anticipated Hydrologic Regime</b>                                                                                                                                                                                                                                            |
|-------------------------------|----------------------------------------------|---------------------------------------------------------------------------------------------------------------------------------------------------------------------------------------------------------------------------------------------------------------------------------|
| Forest Wetland                | East Basin: 42 to 46<br>West Basin: 47 to 49 | Seasonally saturated soil during years of typical rainfall. During a 10-year flood, <sup>a</sup> flooding of up to 3 ft for up to 9 consecutive days would occur. Soil would be unsaturated to at least 18 inches below the ground surface during most summer and fall periods. |
| Shrub Wetland                 | East Basin: 41 to 42<br>West Basin: 44 to 47 | Seasonally saturated or flooded with up to 1 ft of water during years of average rainfall. During a 10-year flood, water could be up to 4 ft deep for 9 consecutive days. Soil would generally be saturated within 12 inches of the ground                                      |

<sup>48</sup> Excavation in the east wetland basin will include construction of a flood conveyance channel and water level control structure that will establish typical wet-season water levels at or near 41 ft elevation (see Appendix E, Sheet C8.2). The basin on the west side will be a closed depression, with water elevations and depths maintained by seasonal variations in groundwater hydrology.

**Table 7.3-1. Proposed wetland classes, elevation ranges, and hydrologic regimes (continued).**

| Proposed Wetland Class | Proposed Elevation Range (ft)                | Anticipated Hydrologic Regime                                                                                                                                                                                                                                                                                                                                                                                             |
|------------------------|----------------------------------------------|---------------------------------------------------------------------------------------------------------------------------------------------------------------------------------------------------------------------------------------------------------------------------------------------------------------------------------------------------------------------------------------------------------------------------|
| Persistent Emergent    | East Basin: 38 to 41<br>West Basin: 42 to 44 | surface during most of the summer and early fall.                                                                                                                                                                                                                                                                                                                                                                         |
| Open-water/Unvegetated | East Basin: Below 38<br>West Basin: Below 42 | Seasonally flooded with up to 4 ft of water during years of average rainfall. The water table would be at or within 6 inches of the ground surface during late summer and early fall.<br>Permanently to semi-permanently flooded during years of average rainfall. Surface water would generally be 6 to 24 inches deep during late summer and early fall, but may not be present during years of extremely low rainfall. |

<sup>a</sup> Only the east basin will lie in the floodplain of the Green River. Because of flood control management of the Green River discharge, the peak flows for 10-year and 100-year flood events are equivalent. All recorded flows that could inundate the wetland have occurred between November and early March. In most years, flood inundation would not occur, or would be for periods of one to several days. The maximum period of inundation is less than 9 consecutive days which occurs during cold weather or the dormant period when the common types of wetland vegetation planned for the site are not susceptible to impacts from short duration flood events.

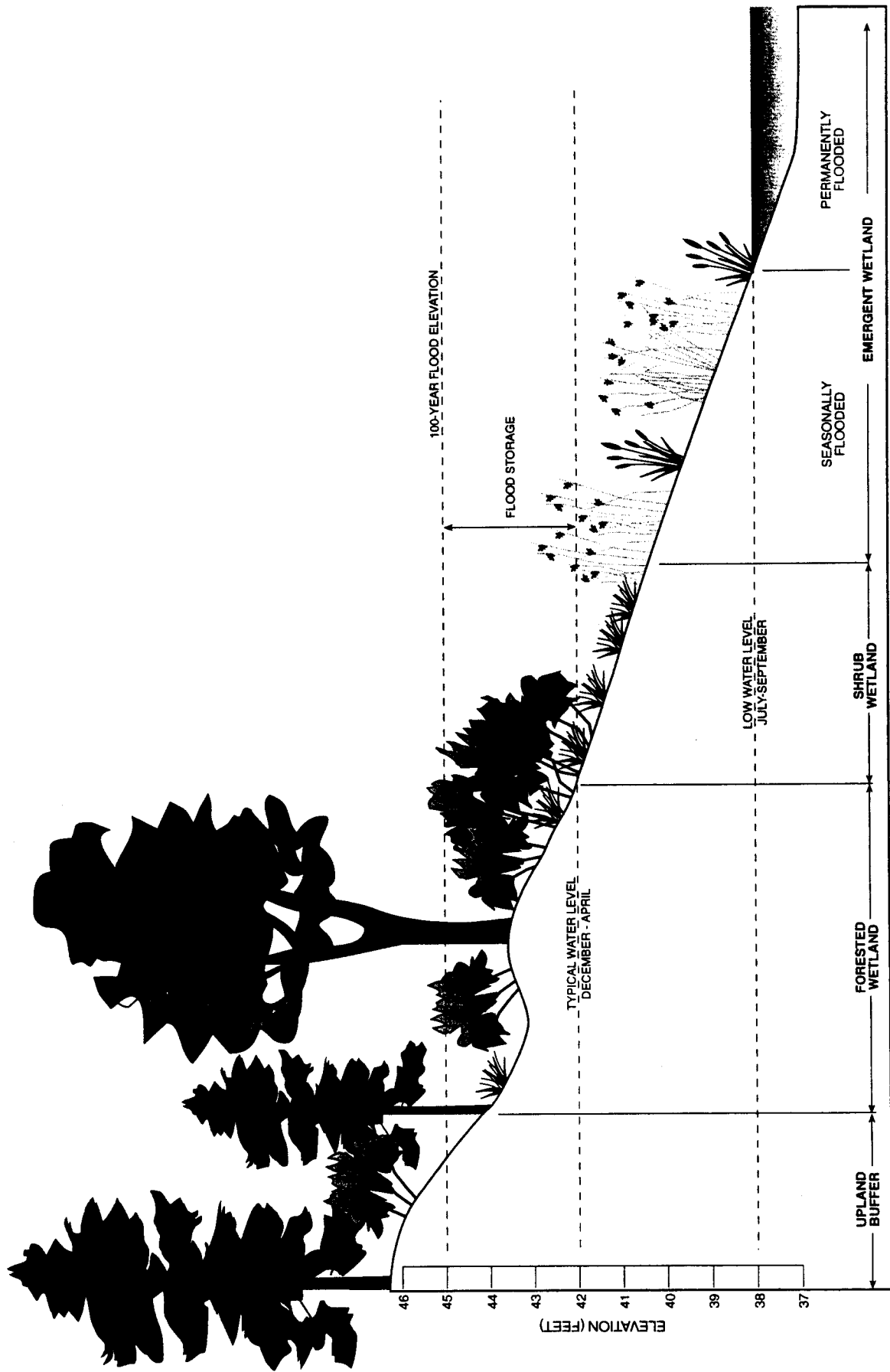
The new wetland areas in the east basin will be connected to the 100-year floodplain of Green River (FEMA 1989) by constructing a vegetated swale from existing ditches located along South 277<sup>th</sup> Street to the northwest corner of the wetland (see Figure 7.2-4 and 7.2.-1). The ditches along South 277<sup>th</sup> Street lie within the 100-year flood plain, and also connect to the Green River via a ditch along 86<sup>th</sup> Avenue South and Auburn Creek. The bottom elevation of the constructed ditch will be at 41 ft, about 3 ft below the elevation of the 100-year flood. The new ditch connecting to the floodplain will allow the east wetland basin to become inundated during 100-year flood events, as backwater flooding from the Green River reaches the site through the ditch system (see Figure 7.2-4).

The wetland mitigation is not, however, dependent on Green River flood events to maintain wetland hydrology, as flooding is too infrequent and for too short of a time period to independently maintain wetland hydrology (see Table 7.3-1). Wetland hydrology will be maintained by the seasonally high groundwater elevations found on the site, and documented in Figures 7.2-9 to 7.2-11.

During the 100-year flood event (when flows exceed 8,500 cfs), water levels in the east basin will increase by up to 3 ft. The frequency of inundation due to Green River flooding is low, with flood events occurring exclusively between November 10 and March 21 (Figure 7.3-2, see Table 7.3-1). The duration of flood events is also short, generally occurring for 1 to several days. Since 1970, two flood events have occurred in March, each about 2 days in duration. The longest period of flooding occurred for 10 days in December 1975.

The hydrologic regimes for the east and west basins will support the vegetation desired to establish wetland functions discussed in Section 7.2.5.4, and required to replace avian habitat functions lost near STIA. Since all plants proposed for the wetland mitigation areas are adapted to a fluctuating water table and periodic inundation (which is common during winter months in floodplain wetlands of western Washington), plant “die-back” as a result of flooding will not occur. All plant species listed in Table 7.2-8 are expected to be tolerant of infrequent and brief periods of inundation during

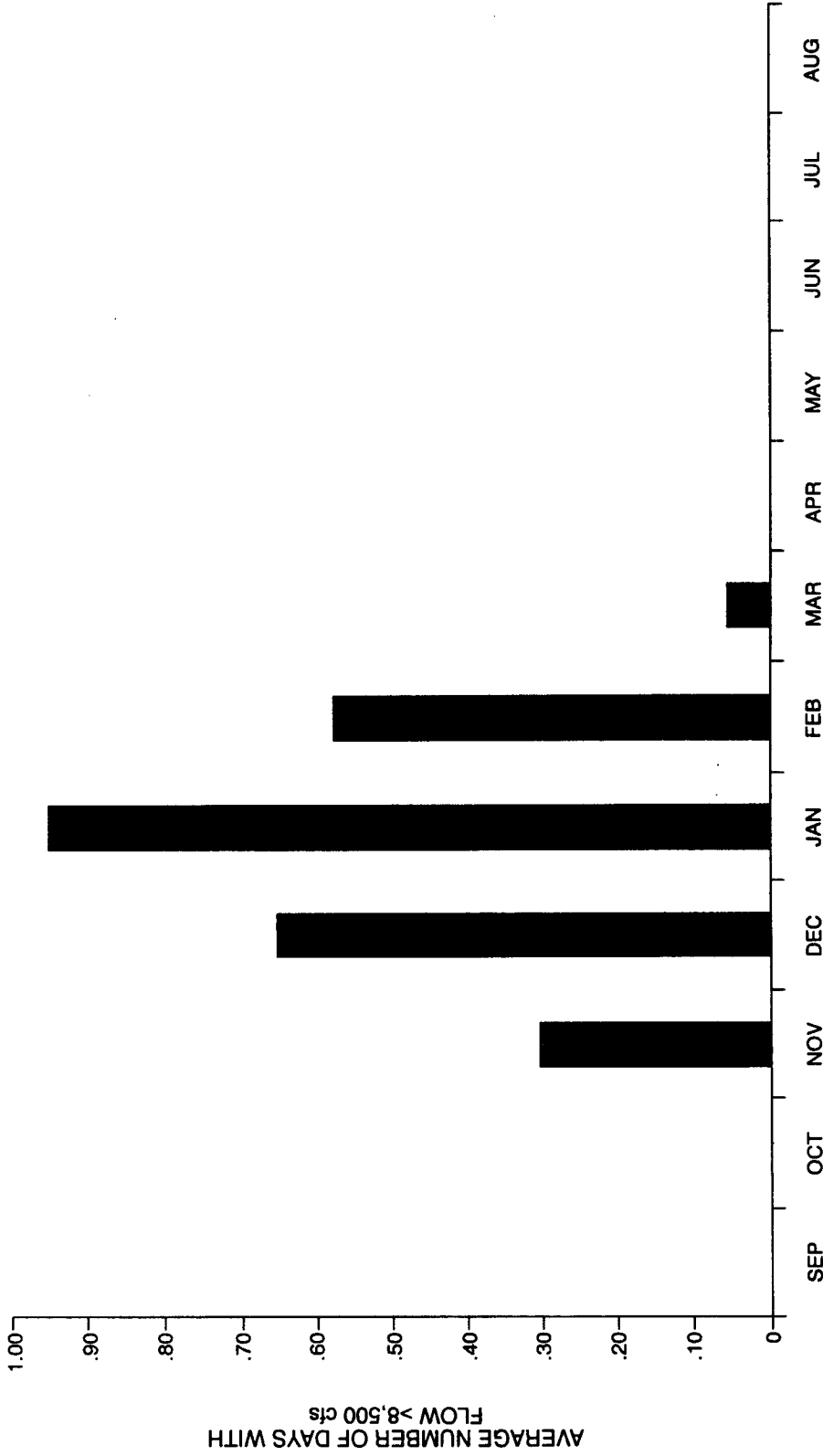




Port of Seattle/Natural Resource Mitigation Plan/556-2912-001.01(03) 12/00 (K)

**Figure 7.3-1**  
**Relationship of Seasonal Water Level**  
**Variations and Soil Surface Elevations**  
**to Proposed Wetland Vegetation Classes**

Data Compiled by Parametrix



USGS 1996

Port of Seattle/Natural Resource Mitigation Plan/556-2912-007/01(03) 12/00 (K)

**Figure 7.3-2  
Green River Flood Frequency by Month  
(Based on 1960-1996 Data for Auburn)**

the dormant period, and these species are commonly found in uplands and wetlands on the floodplains of northwest rivers. Because of the timing, duration, and frequency of flood events, they are not expected to affect plant survival on the site. Plant survival will largely be a result of each species' tolerance of wet soil conditions, as reflected by their "wetland indicator status" (see Tables 7.2-4 and 7.2-8). To provide additional flexibility in the control of site hydrology in the east basin over the first few years of monitoring, an outlet control structure will be constructed near the northwest portion of the site to regulate water levels in the wetland. The water levels will be adjusted by raising or lowering control gates, thereby raising or lowering water levels (Appendix E, Sheets C3, C5, and C8). However, the weir will be permanently fixed once planting is completed and the site has been monitored for up to several years.

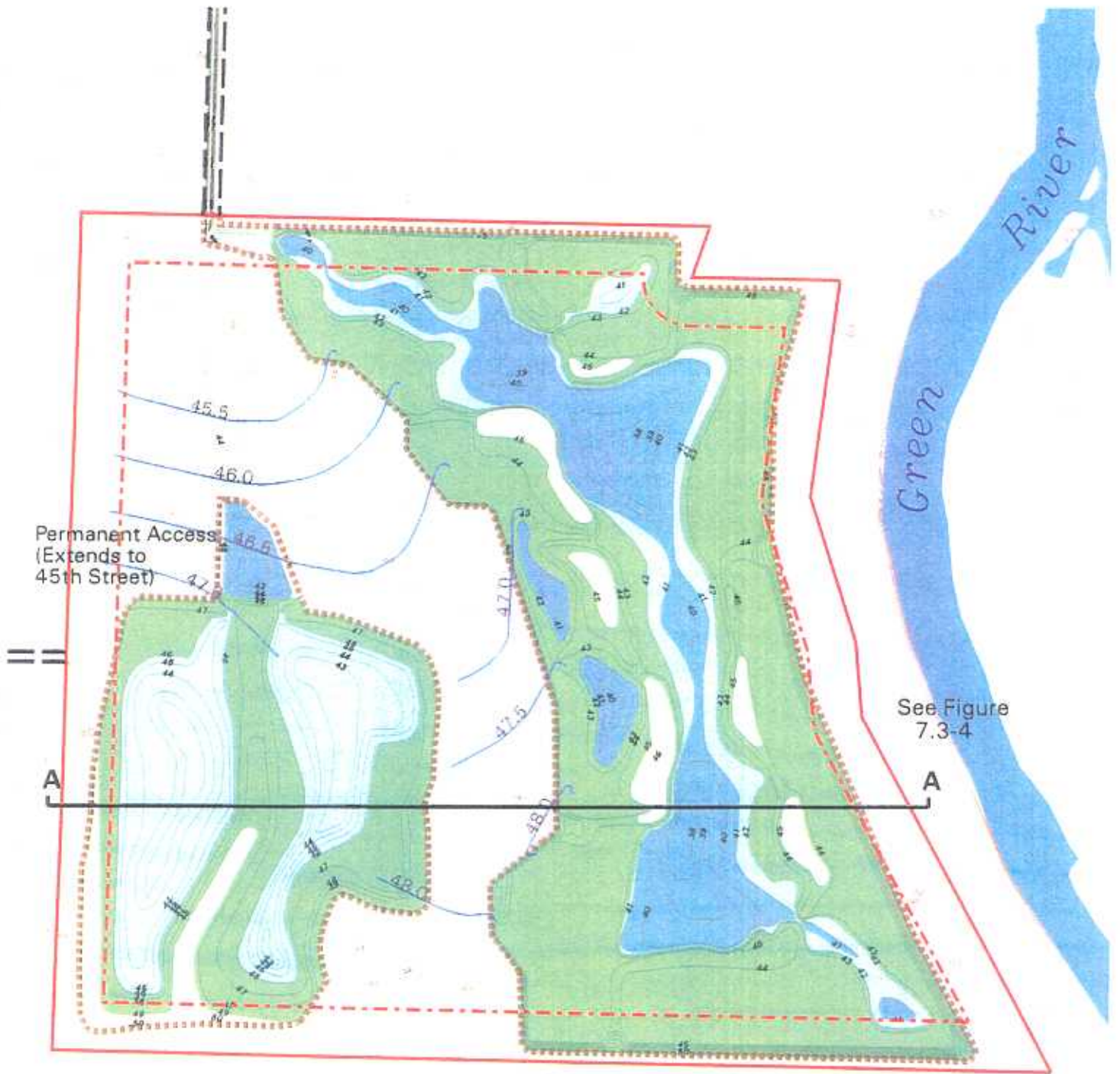
For the east basin, the combination of drainage channels and weir, coupled with the grading plan (described below), will assure that saturated soil conditions (and not long-term inundation) occur in the forest and shrub wetland planting zones (see Table 7.3-1). The weir and drainage channel will result in a free-draining wetland basin that will maintain soil saturation (not inundation) above elevation 41 ft. This soil saturation will be maintained even when the groundwater elevations in surrounding soils exceeded 41 ft, because the drainage channel and weir will prevent inundation of the new ground surface.

For the west basin, the water levels in excavated depressions will be controlled by groundwater conditions on the site since there will be no new channel excavation to connect the basin to the floodplain and other ditches. This grading has been planned to allow vegetation zones to be established as indicated in Table 7.3-1. In the forested zone, the ground surface elevations to be established are based on hydrologic monitoring summarized in Figures 7.2-9 to 7.2-11. The hydrologic monitoring indicated that native vegetation with a wetland indicator status of FAC, FAC+, FACW-, or FACW will be adapted to this hydrologic regime, as shown in Section 7.3.4. Similarly, for other planting zones, the hydrologic regime of the wetland is matched to the tolerance of wetland vegetation to saturated and/or inundated soils. Section 7.3.4 provides additional information regarding plant selection and planting zones.

During the initial plant establishment phase, some control of water levels may be required to optimize establishment and survival of the planted stock. Any necessary adjustments to water regime are anticipated to be minor and short term, and should not be necessary after plants become established. The Port will monitor site hydrology and plant survival carefully during the first few growing seasons and any adjustments to site water levels will be based on these monitoring results. The Port's wetland scientist will adjust outlet control structures, and adjustments will be fully documented in monitoring reports. Following this initial plant establishment period, and based on any water level adjustments made during the first few years, the outlet control structure will be set at a fixed elevation appropriate for the site. No long-term adjustments to the outlet control structure or site water levels are anticipated.

### **7.3.2 Grading**

One basin will be excavated east and another basin southwest of the existing wetlands to create two new wetland areas (Figures 7.3-3 and 7.3-4; Appendix E, Sheets C2 through C7). Excavation will generally be to depths between 1 and 5 ft below the existing ground surface to intercept the seasonally high or permanent groundwater table (see Section 7.3.1 for an explanation of the hydrologic regime to be established by this grading plan). Excavation depths will be less in the west



AR 049352

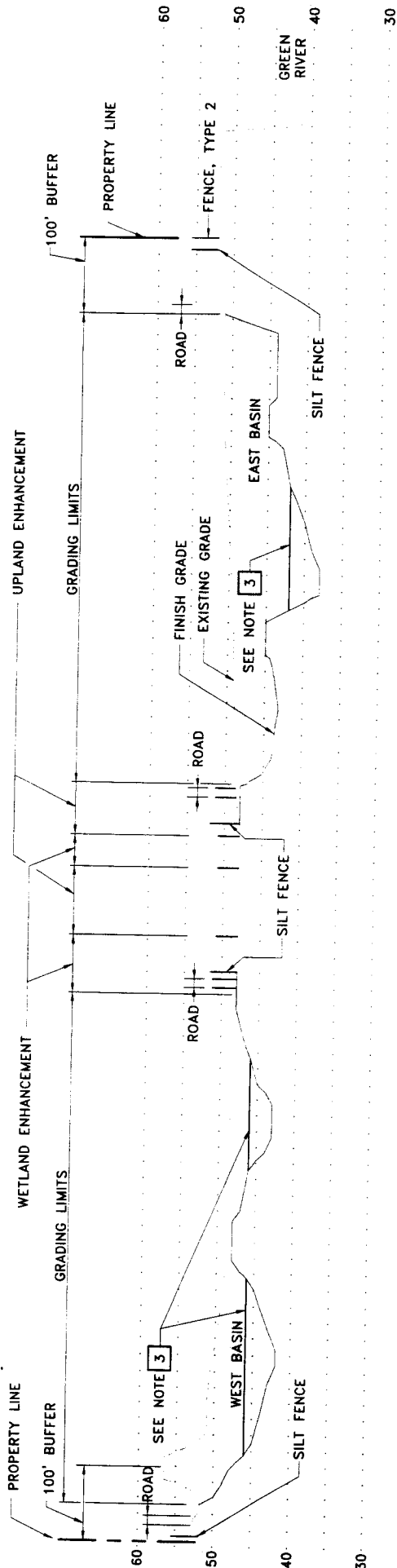
Prepared by Parametrix, Inc. File: seatac\_auburn/plot/mis/8x11/auburn\_grade062701.dwg created by p8x11/aub\_grade-062701.grs Date: June 28, 2001

NRMP 2000



- |                                |                       |                  |
|--------------------------------|-----------------------|------------------|
| Existing Wetland               | Property Boundary     | New Contour      |
| New Wetland (Saturated Soil)   | 100 Foot Buffer       | Existing Contour |
| Standing Water (Elevation 41') | Easement              |                  |
| Standing Water (Elevation 42') | Excavation Limit      |                  |
|                                | Groundwater Elevation |                  |

**Figure 7.3-3**  
Wetland Mitigation  
Grading Plan and  
Hydrology  
(Early Spring)



SECTION A-A  
 HORIZ. 1"=100'  
 VERT. 1"=10'

NOTES:

- [1] WETLAND SOIL TYPE 1 SHALL BE USED AT 4.0 AND ABOVE FOR ALL AREAS WITHIN THE 100' BUFFER. WETLAND SOIL TYPE 2 SHALL BE PLACED BELOW ELEVATION 41.0 WITHIN THE AREA SHOWN ON THE PLAN.
- [2] GRADE SHOWN AT THIS POINT WILL VARY BETWEEN 36.14 AND 34.14 TO REFLECT VARIATION IN UPLAND/METLAND BOUNDARY.
- [3] TYPICAL EARLY SPRING WATER LEVELS.

Figure 7.3-4  
 Wetland Mitigation  
 Cross Section

AR 049353

basin due to higher groundwater elevations, as well as to avoid impacts to the existing wetlands east of this basin. Due to site constraints, an area north of the west wetland basin will be used as a temporary staging area during construction. This area will be restored and enhanced after construction is complete (see Section 7.4.4).

Due to the high water table, the site will be dewatered prior to and during grading. Grading and site work other than planting will take place during the dry season (e.g., June through September). Site grading may take place in phases, if necessary, to ensure that all grading and site stabilization (e.g., hydroseed) can take place in one construction season. If construction of both basins cannot be completed in the same season (i.e., excavation, final grading, site stabilization), then the east basin will be constructed first and the west basin the following year. Construction is currently anticipated to begin during the 2002 dry season. Major construction activities will be limited to the period from October 31 to March 31 to avoid any disturbance to wintering bald eagles that may be in the vicinity of the Green River.

The proposed grading will affect about 11.9 acres of the existing emergent wetland that is described in Section 7.2.5.1 (see Table 3.1-4). In addition, a maximum of 2.2 acres of low-quality emergent wetland and existing wetland drainage ditches (located north of the site) will be widened to connect with the 100-year floodplain and existing ditch systems, which will provide floodwater storage and conveyance functions. Approximately 0.12 acre of existing wetland will be permanently impacted by access roads. However, no net loss of wetland area will result due to the temporary use of access roads, their restoration, and wetland creation actions planned for the remainder of the site.

Temporary maintenance roads will be constructed around each wetland basin to provide access to the site during planting, maintenance, and monitoring. These roads will be removed and the areas restored and enhanced with native vegetation after construction is complete and monitoring.

#### **7.3.2.1 Surface Soil Removal**

The first grading step will be to strip off the top 12 inches of soil, which will be disposed of in an approved, upland location off site. Removal of this soil will remove rhizomes, roots, and seeds of the existing vegetation, and minimize re-colonization by non-native plants after native plants are installed. Suitable subsoil material removed during excavation will be stockpiled, amended with composted organic material that is free of weeds, spread to a depth of 12 inches, and disced into the subsoil prior to installing plants. Approximately one-third of the excavated soil will be stockpiled for use as topsoil in the new basins. Soils that become compacted during grading will be ripped and/or disced to break it up and provide a suitable rooting medium for plants.

#### **7.3.2.2 Basin Excavation and Dewatering**

Approximately 440,000 cy of soil will be excavated to create the two wetland basins. Excavation depths will range between 1 and 8 ft. Due to seasonally high groundwater levels on this site, dewatering will likely be necessary to allow excavation of the new wetland basins and site grading. Water from site dewatering will be conveyed through a series of sediment/settling ponds and straw bale filters to existing ditches that drain the site at the northwest corner.

### **Dewatering Plan**

All dewatering will be performed according to conditions of the HPA obtained for the project. The Port estimates that the current groundwater table should be lowered approximately 5 ft below the subgrade to facilitate grading. The dewatering plan will use approximately 45 to 50 wells that extend into the shallow groundwater table. To lower the water table sufficiently to allow grading, water will be pumped off site via these wells. Groundwater will be conveyed to the existing ditch that drains the site. It is estimated that dewatering on the project site could discharge up to 4,600 gallons per minute of groundwater while the excavation is occurring. The highest discharge rates are anticipated to occur early in the construction season (May or June), with little discharge occurring in August or September.

Two retention ponds will be constructed to capture runoff from the Phase 1 construction staging area located on the northwest portion of the site. Based on design criteria and runoff modeling, the minimum total storage volume required is 3.65 acre-ft. This volume will contain the 25-year summer storm event, with a 1.5 factor of safety. A smaller pond, able to retain at least 0.77 acre-ft of runoff, will serve the northern section of the staging area. A larger pond, with a minimum storage capacity of 3.65 acre-ft, will collect runoff from the remaining portion of the site as well as the pumped discharge from the smaller pond.

Sediment in the pond water will be removed by an on-site alum treatment facility. The treatment facility will consist of three coagulation tanks and one settling tank. Additional coagulation tanks will be utilized if necessary. While treated water from the facility will be discharged off site, any treatment plant bypass water will be discharged on site. In addition, sediment from the facility will be redeposited on site. Surface water that accumulates during excavation will also be treated prior to being discharged from the site. All water discharged from the site must meet turbidity standards for water quality. These standards are less than 5 NTUs above background when background levels are less than 50 NTUs, and no more than 10 percent above background when background levels are more than 50 NTUs.

Ditches through which dewatering water passes will be evaluated for stability and erosion potential. Where necessary, stabilization (such as hydroseeding or other methods) will be employed.

### **Drainage Easements for Dewatering**

The Port has procured a temporary drainage and construction easement across the property north of the mitigation site that allows use of an existing channel for drainage purposes. The easement also grants the Port the right to use this channel to temporarily discharge water from dewatering wells to be used during construction of the Port's wetlands. During the dewatering process, water will be temporarily channeled to the existing outfall into the Green River at South 277<sup>th</sup> Street. Other than during the dewatering process, drainage water from the Port's property will flow north through existing drainage channels along and under South 277<sup>th</sup> Street, and discharge to the Green River north of South 277<sup>th</sup> Street. The newly constructed wetland basins will generally drain to the northwest at elevations of 42 ft (east basin) and 46 ft (west basin). The temporary drainage and construction easement remains in effect until a permanent flood channel is constructed.

The location of the temporary drainage channel is shown on Appendix E, Sheet C3. A cross-section schematic of the temporary drainage channel (i.e., wetland outlet ditch) is shown on Appendix E, Sheet C8.

### **Effects of Dewatering on Existing Wetlands**

Dewatering activities on the Auburn site are not likely to affect the hydrology or habitat conditions in existing wetlands located on, near, or adjacent to the mitigation site. Dewatering of the site will occur from approximately May through September, over one or two construction seasons.<sup>49</sup> The purpose of dewatering is to accelerate the rate at which the water table falls during late spring, and assure that during construction the water table is below the proposed grades of the site. During the spring months and subsequent summer, the water table in the wetlands normally falls about 6 to 8 ft over a period of 4 to 5 months (see Figures 7.2-5, 7.2-6, and 7.2-7). In May, at the time dewatering starts, the water level in the wetlands is typically 24 inches below the ground surface, and thus below the rooting zone of wetland plants. By late May, it is as much as 36 inches below the ground surface and below the rooting zone of the herbaceous vegetation present on the site. Because the timing of dewatering is such that it will occur after water levels in the wetlands have already dropped below the root zone, wetland vegetation will not be impacted by further lowering of the water table through construction dewatering. Since surface water is not present, dewatering will not remove surface water that could provide special habitat types to wildlife.

Construction dewatering is not proposed to lower the water table below the elevation it normally reaches by late summer. Thus, during the fall, when soil moisture and groundwater recharge begin, recharge rates and requirements in adjacent wetlands will be the same as if dewatering had not occurred. Thus, dewatering will not increase the length of time required for the water table to rise again in the fall.

#### **7.3.2.3 Topsoil Replacement and Finish Grading**

Native subsoils at the Auburn site are a mix of silts and fine sands, and will be used to construct an amended topsoil for the site. Approximately one-third of the excavated material will be selectively stockpiled either at on-site staging areas, or off site, for use as backfill and to construct topsoil for the excavated areas.

Two types of soil amendments will be used to provide a suitable substrate for wetland plant establishment on the site. The first soil type (Wetland Soil 1) will be a 3:1 mix of suitable native subsoils with organic compost that is free of weed seeds or other unsuitable material. This soil will be used above 42 ft elevation in the east basin and throughout the excavated area of the west basin (Appendix E, Sheet C9). The second soil type (Wetland Soil 2) will be used below 42 ft in elevation in the east basin to provide soil for the emergent planting zone (Appendix E, Sheet C9). Native subsoils on the site are a mix of sands, silts, and clays, and naturally formed layers that are relatively impervious. To ensure that subsoils used in the emergent planting zones maintain this relative impermeability, Wetland Soil 2 will be native subsoil amended with 4 percent bentonite.

Final grades will establish elevation and hydrologic gradients that will allow the planting of the desired native plant community types (see Figure 7.3-4). Fine grading and habitat log placement will also establish a complex microtopography on the site, which will enhance water storage and microhabitat diversity (Appendix E, Sheet 8.2). Habitat log placement and installation of snags will enhance wildlife functions on the site. The landscape architect and/or wetland scientist will place

---

<sup>49</sup> If construction were to occur over two seasons, only portions of the site would be dewatered during the second season.



logs, snags, and field direct fine grading. Microtopography will be established by constructing a series of 'pit and mound' features in the forested and shrub wetland areas. Pit and mound features are designed to simulate the microtopography created by windthrow of large trees. Pit and mound features will be constructed at a density of approximately four per acre. Habitat logs will be placed predominantly in forested and shrub wetland classes, with a density of approximately 15 per acre (Appendix E, Sheet C9).

#### 7.3.2.4 Hydroseed

Following completion of fine grading and topsoil placement, the soil surface will be stabilized with a hydroseed mix. Hydroseed mixes have been designed to accomplish several objectives. Hydroseeding is part of the TESC measures and will provide short-term stabilization of the soil surface and erosion control following grading. Hydroseeding will also allow rapid establishment of ground cover and serve as a weed barrier to reduce colonization of the open site by invasive species. In addition, native herbaceous understory species for the forest, shrub, and emergent communities will be provided by hydroseeding prior to planting the overstory vegetation in these zones.

Hydroseeding will use one of three seed mixes, with the mix selected for each zone matched to the site moisture conditions in that zone (Table 7.3-2). A wet zone seed mix consisting of OBL and FACW species will be used below 43 ft in the east basin and below 46 ft in the west basin (see Figure 7.3-4). A transition zone seed mix consisting of FACW, FAC+, and FAC rated species will be used from 43 to 45 ft in the east basin and from 46 to 49 ft in the west basin. A native buffer seed mix consisting of FAC, FAC+, FAC-, and FACU rated species will be used in the forested buffer areas above 45 ft in the east basin and above 49 ft in the west basin. In addition, a low-grow seed mix will be used to vegetate temporary construction access roads and staging areas that are located outside the mitigation area.

Hydroseed mixes will be comprised predominantly of native grass, sedge, and rush species. However, some non-native grasses may be included to provide rapid germination and growth for erosion and weed control. Use of non-natives will be restricted to species that are not invasive, and will not persist once the planted stock becomes established and canopies become closed. The buffer zone hydroseed mix is designed to establish a low-growing ground cover of grasses that will protect the soil and reduce erosion while minimizing competition with the planted stock. The wetland and transition seed mixes are designed to supplement the container stock by increasing ground cover and plant density.

Table 7.3-2. Hydroseed mixtures.

| Common name                                                                     | Scientific Name               | % by weight |
|---------------------------------------------------------------------------------|-------------------------------|-------------|
| <b>For use in areas designated as emergent wetland</b>                          |                               |             |
| Tall mannagrass                                                                 | <i>Glyceria elata</i>         | 15          |
| Water foxtail                                                                   | <i>Alopecurus geniculatus</i> | 10          |
| Water parsley                                                                   | <i>Oenanthe sarmentosa</i>    | 10          |
| Slough sedge                                                                    | <i>Carex obnupta</i>          | 10          |
| Beaked sedge                                                                    | <i>Carex rostrata</i>         | 15          |
| Small-fruited bulrush                                                           | <i>Scirpus microcarpus</i>    | 15          |
| Woolgrass                                                                       | <i>Scirpus cyperinus</i>      | 10          |
| Dagger leaf rush                                                                | <i>Juncus ensifolius</i>      | 5           |
| Taper tip rush                                                                  | <i>Juncus acuminatus</i>      | 5           |
| Slough grass                                                                    | <i>Beckmania syzigachne</i>   | 5           |
| <b>For use in areas designated as forested or shrub wetland and wet buffers</b> |                               |             |
| Blue wildrye                                                                    | <i>Elymus glaucus</i>         | 25          |
| Western mannagrass                                                              | <i>Glyceria occidentalis</i>  | 8           |
| Tall mannagrass                                                                 | <i>Glyceria elata</i>         | 10          |
| Tufted hairgrass                                                                | <i>Deschampsia cespitosa</i>  | 10          |
| Annual ryegrass                                                                 | <i>Lolium multiflorum</i>     | 15          |
| Chewings red fescue                                                             | <i>Festuca rubra</i>          | 10          |
| Meadow foxtail                                                                  | <i>Alopecurus pratensis</i>   | 10          |
| Bentgrass                                                                       | <i>Agrostis tenuis</i>        | 10          |
| Alsike clover                                                                   | <i>Trifolium hybridum</i>     | 2           |
| <b>For use in upland buffer areas</b>                                           |                               |             |
| Barkley's perennial ryegrass                                                    | <i>Lolium perenne</i>         | 30          |
| Red fescue                                                                      | <i>Festuca rubra</i>          | 35          |
| Aurora hard fescue                                                              | <i>Festuca longifolia</i>     | 35          |

### 7.3.2.5 Temporary Irrigation

An irrigation system will be installed on the mitigation site (Appendix E, Sheets L1 through L3). Irrigation with municipal water purchased by the Port will be used during the initial stages of the restoration to optimize conditions for plant establishment. Irrigation will provide flexibility in the timing of plant installation, increase survival rates, and enhance growth rates of the planted stock. Enhancing plant growth during the first few years will lead to a more rapid establishment of canopy cover and shade on the site, and reduce re-invasion of the site by non-natives.

The irrigation system will be installed, tested, and fully operational before plants are installed. Irrigation in the existing wetland will be installed above ground to minimize ground disturbance. Irrigation in the areas to be excavated and graded will be installed below ground.

The irrigation system will be sufficiently durable to provide irrigation to the site throughout the first 10 years of the monitoring period. However, the system will be used the first few (one to three) growing seasons depending on weather conditions, time of planting, etc. In subsequent years irrigation would be used in limited areas if replanting was required.<sup>50</sup> Irrigation will likely be used during the June through September time period, depending on weather conditions. Application rates are planned to be less than agronomic rates, but sufficient to reduce plant mortality and promote plant growth during the first season following planting. Once the system is no longer needed, the system will be removed and decommissioned.

### 7.3.3 Landscape Plan

Native species will be planted to establish forested wetland, shrub wetland, and emergent wetland plant communities, as well as a forested upland buffer around the edges of the site (Figure 7.3-5; Appendix E, Sheets L5 through L10). These general community types will include six wetland plant associations (or planting zones) typical of freshwater wetlands and forested uplands in the northern Puget Sound basin (Figure 7.3-6). Choice of plant species, planting densities, and community composition is based primarily on composition and densities of local wetland plant communities (Kunze 1994).<sup>51</sup> In addition, plant species were chosen for their value as food sources or habitat elements for wildlife. For example, the design includes shrubs and emergent plants that are particularly valuable as wildlife food sources (e.g., hazelnut, Indian plum, sedges, and bulrushes).

Forest wetland plant communities include black cottonwood/Pacific willow, red alder/salmonberry, Oregon ash/Pacific willow, and western redcedar plant communities. A dogwood/willow shrub community and a grass, beaked sedge/water parsley emergent community will be planted in wetter portions of the site, surrounding small areas of open water in the centers of the basins. Planting black cottonwood, Oregon ash and red alder will enhance the existing emergent wetland and the forested communities will increase plant diversity and enhance wildlife habitat (Appendix E, Sheets L5 through L10). The upland buffer will be planted with a mix of native trees and shrubs such as Douglas fir, big-leaf maple, vine maple, hawthorn, and Indian plum (Appendix E, Sheet L10).

Along the boundaries of the site, the upland buffers will be planted densely adjacent to the perimeter fence with species likely to discourage intrusion into the site (e.g., tall Oregon grape [*Mahonia aquifolium*], hawthorn, rose). Planting may occur in phases, with an initial planting of rapidly growing plants tolerant of full sun followed by a second planting of species that are more shade tolerant.

The following sections describe the general planting approach for each planting zone. The sections identify the types of plant species, the condition of material planted (container, bareroot, live stakes, seed, or plugs), and the planting approach (density, pattern, and area of coverage). At the time of planting, minor variations in the plantings may occur to account for site-specific factors and the planting season. For example, if an area is planted in late spring or summer, container-grown versus live-stake material will be used. Similarly, during late fall, winter, or early spring plantings, a greater amount of bareroot and live-stake versus container-grown material will be planted.

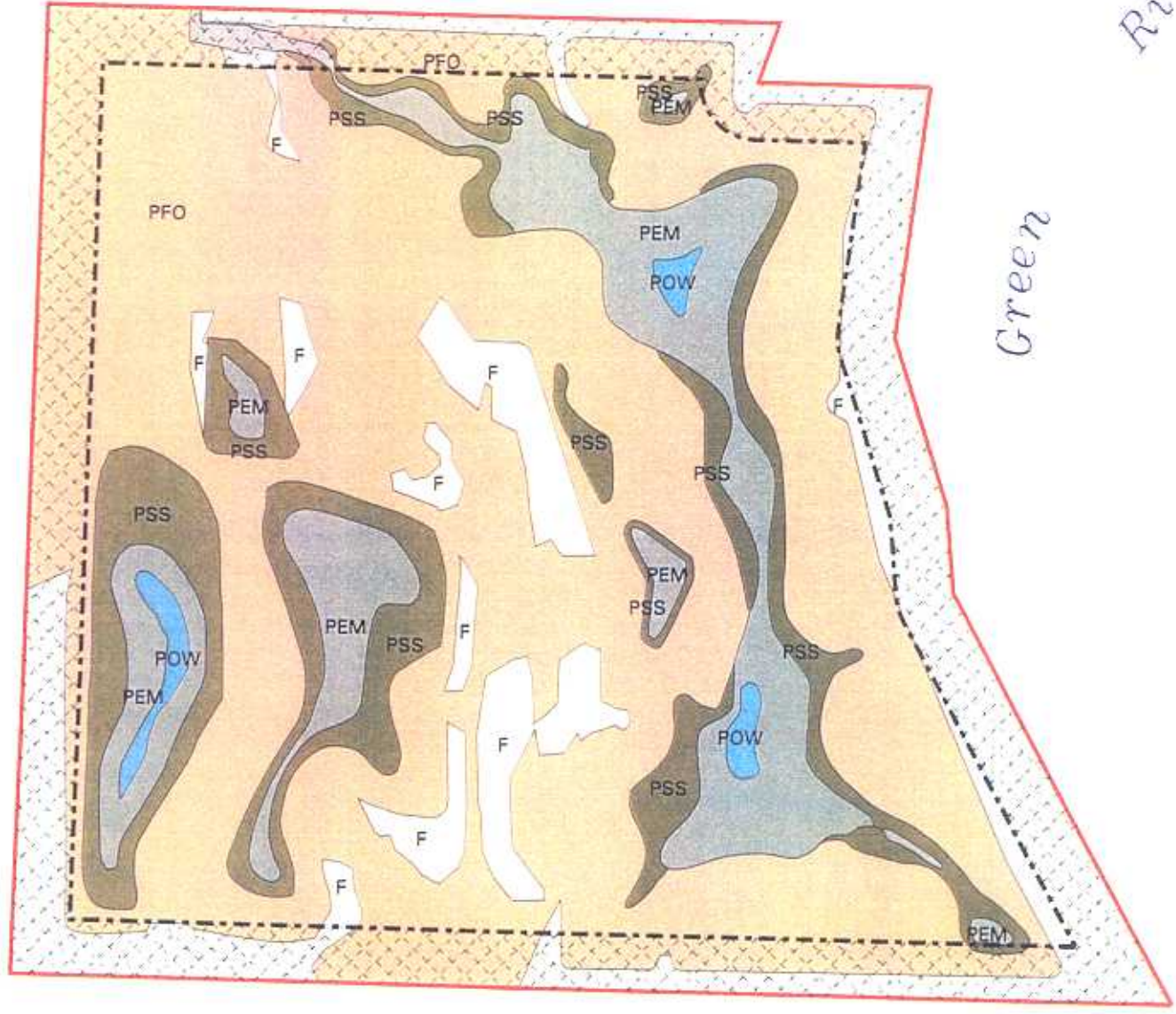
---

<sup>50</sup> Due to performance requirement of 80 percent tree and shrub survival by year 3 and phased planting of conifers in year 3, irrigation in year 4 may also be necessary.

<sup>51</sup> The relation of the wetland zones to the hydrologic conditions is generally discussed in Section 7.3.1. The specific considerations in placing particular species and community types at various elevations are discussed in Section 7.3.4.

River

Green



AR 049360

Prepared by Parametrix, Inc. File: \\projects\seatan\_suburb\plotamis\plots\p8x1\suburb\_classes\_fig2.gra Date: November 13, 2001



- Palustrine Forested (PFO)
- Palustrine Scrub/Shrub (PSS)
- Palustrine Emergent (PEM)
- Palustrine Open Water (POW)
- Forested Upland (F)
- Buffer
- 100-Foot Buffer
- Property Boundary

Figure 7.3-5  
Wetland Vegetation  
Classes for the  
Wetland Mitigation  
Site



AR 049361

Prepared by Parametrix, Inc. File: searac\_auburn/plotamis/8x11auburn\_plantut2.amf creating p8x11auburn\_plantut2.gra Date: November 13, 2001





- |                                                                                                           |                                                                                                                   |                                                                                                        |
|-----------------------------------------------------------------------------------------------------------|-------------------------------------------------------------------------------------------------------------------|--------------------------------------------------------------------------------------------------------|
|  Black Cottonwood (BC) |  Western Redcedar (WR)         |  Property Boundary |
|  Red Alder (RA)        |  Shrub Wetland (SW)            |  100-Foot Buffer   |
|  Oregon Ash (OA)       |  Emergent Wetland (EW)         |                                                                                                        |
|  Mixed Forest (M)      |  Open Water Non-vegetated (OW) |                                                                                                        |

Figure 7.3-6  
Plant Associations  
for the Wetland  
Mitigation Site

Figure 7.2-14 depicts the expected growth pattern of the plantings as time progresses. It is anticipated that a mature forested wetland system will develop within 50 years.

The landscape plan for the area shows that the planting of conifer trees is phased (see landscape design sheets in Appendix E). It is anticipated that these conifers would be planted in a second planting phase coincident with replacement plantings that may be required to meet the year three performance standard for plant survival. At this time, the conifer species would be planted. The trees will be positioned such that they receive some shade from adjacent plants (trees, shrubs, and groundcover). For the first growing season following this planting, soil moisture conditions will be examined closely, and the use of the temporary irrigation system may be used to reduce mortality and promote growth.

Plant material used in the mitigation will be obtained from commercial nurseries. Nurseries will be required to certify that the plant material is legally procured and from the appropriate geographic sources. Plant material used will come from an area bounded on the north by the Fraser River Valley of British Columbia, on the east by the 1,000-ft elevation of the Cascades, on the west by the 1,000-ft elevation in the Olympic or Coast ranges, and on the south by the Willamette Valley.

#### 7.3.3.1 Weed Control

Invasive non-native species such as reed canarygrass and Himalayan blackberry can reduce successful establishment of desirable native plant species. A variety of weed control strategies are available to treat non-native species prior to and during the native plant installation period (see Section 4.3.2.4). These control strategies are incorporated into the planting design, or will be implemented during the monitoring period to control invasive species. Weed control methods (in order of preference) are:

- Dense plantings of target species that competitively exclude non-native species.
- Application of sterile straw or other biodegradable mulch as a weed barrier.
- Installation of biodegradable weed barrier fabric.
- Mechanical removal using mowers, line trimmers, or hand removal.
- Applications of EPA-approved herbicides by licensed applicators, as necessary.

Several methods for controlling reed canarygrass are currently proposed. An integrated approach relying on a suite of control strategies (listed above) and adaptive management will be used to control reed canarygrass at the Auburn site.

Topsoil containing weed seed, roots, and rhizomes will be removed to establish appropriate wetland hydrology over much of this site. Existing vegetation, including reed canarygrass, may also be removed from the site by application of approved herbicides, plowing, cultivating, and allowing the site to lie fallow. The project has been designed to anticipate some colonization of reed canarygrass by targeting the establishment of forested wetlands that ultimately will shade out this species. Competitive exclusion will be used early in the planting period by seeding areas with a fast-germinating cover crop (see Table 7.3-2). Competitive grass species such as tufted hairgrass (*Deschampsia cespitosa*), sloughgrass (*Beckmannia syzigachne*), bentgrass, or red fescue can be effective in establishing cover and reducing invasion by reed canarygrass. Contingency actions could include repeated applications of herbicides, mowing, or use of weed barriers.

### 7.3.3.2 Plant Protection from Animals

To deter plant damage by rodents (i.e., herbivory), plants may be installed with protective devices such as plastic stem collars. Depending on the type of community and level of herbivory, deterrence measures may range from plastic collars around individual stems to wire mesh around groups of plants.

### 7.3.3.3 Perimeter Fencing

Fencing will be installed around the perimeter of the site to clearly mark the mitigation boundary and protect the mitigation site from intrusion and damage from people or domestic animals (see Appendix P. In addition to the fence, signs will be posted along the boundary of the mitigation site, designating it as a wetland mitigation area.

## 7.3.4 Native Plant Communities

The planting plan will result in establishing five forested communities, one shrub community, and one emergent community on the site. Four of the forested communities, as well as the shrub and emergent communities, are wetlands. An upland forested community will be planted in buffer zones.

### 7.3.4.1 Forest Communities

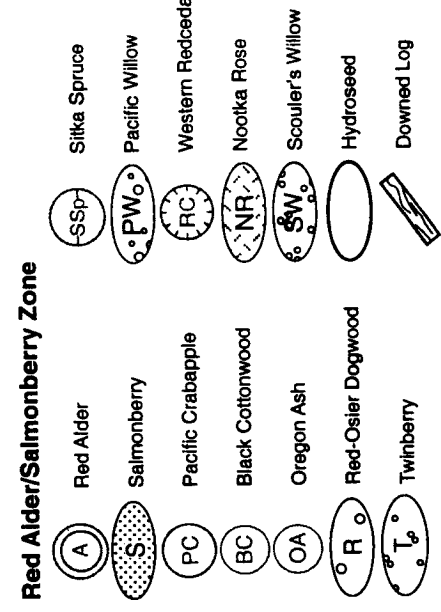
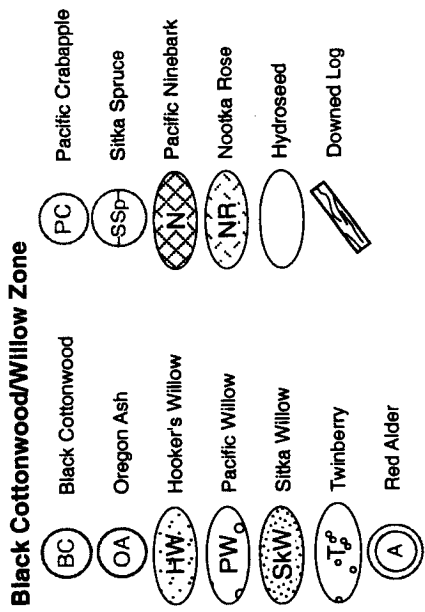
#### Black Cottonwood/Willow Association

The black cottonwood/willow association is characteristic of many floodplain forested wetlands in western Washington, including the Green River valley. The plants within this association (Table 7.3-3 and Figure 7.3-7) are adapted to large fluctuations in the water table and are tolerant of seasonally dry soils. This zone would be planted above elevation 42 ft on the east side and above elevation 47 ft on the west side.

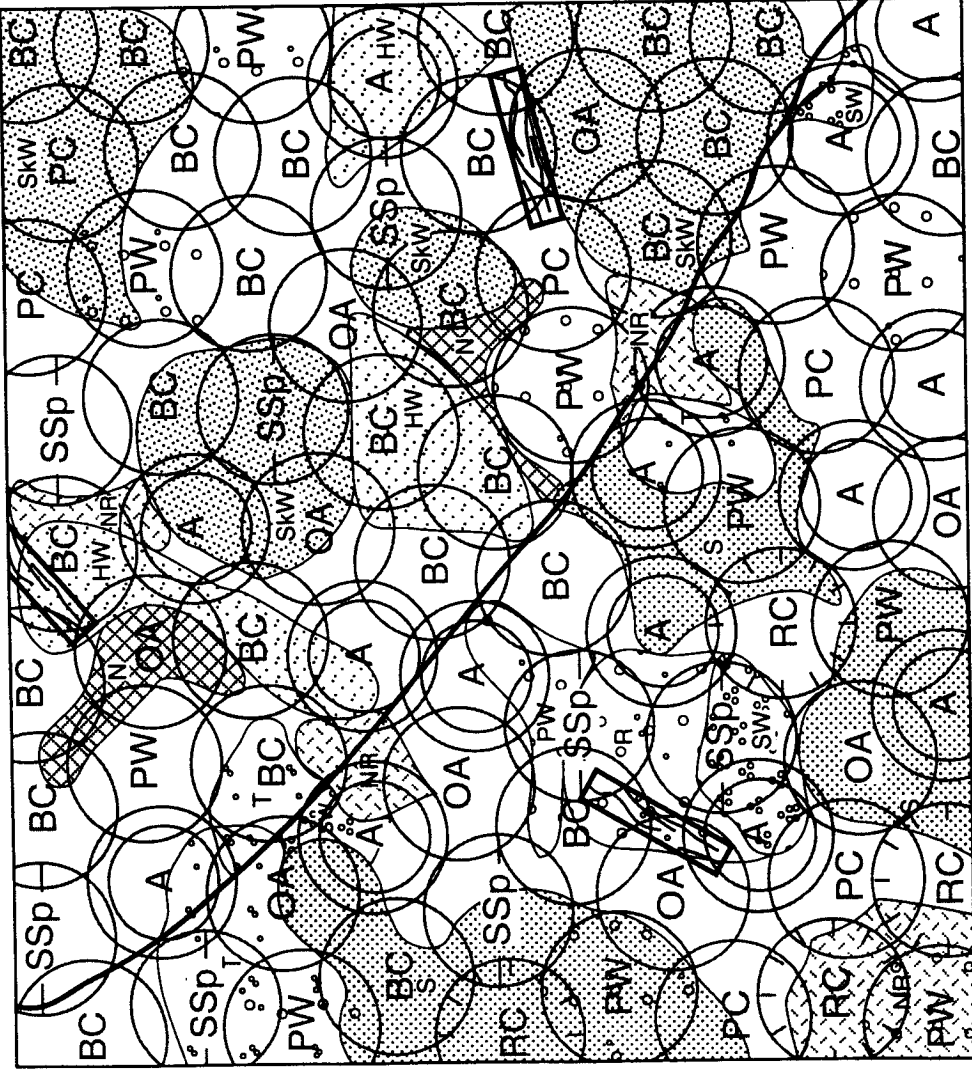
Table 7.3-3. Proposed plant species for the black cottonwood/willow association.

| Scientific Name              | Common Name       | Indicator Status <sup>a</sup> | Condition             |
|------------------------------|-------------------|-------------------------------|-----------------------|
| <b>Trees</b>                 |                   |                               |                       |
| <i>Alnus rubra</i>           | Red alder         | FAC                           | container             |
| <i>Fraxinus latifolia</i>    | Oregon ash        | FACW                          | container             |
| <i>Malus fusca</i>           | Pacific crabapple | FACW                          | container             |
| <i>Picea sitchensis</i>      | Sitka spruce      | FAC                           | container/bareroot    |
| <i>Populus trichocarpa</i>   | Black cottonwood  | FAC                           | container/ live stake |
| <i>Salix lasiandra</i>       | Pacific willow    | FACW+                         | container/ live stake |
| <b>Shrubs</b>                |                   |                               |                       |
| <i>Lonicera involucrata</i>  | Twinberry         | FAC+                          | container             |
| <i>Physocarpus capitatus</i> | Pacific ninebark  | FACW-                         | container             |
| <i>Rosa nutkana</i>          | Nootka rose       | FAC                           | container             |
| <i>Salix hookeriana</i>      | Hooker's willow   | FACW                          | container/ live stake |
| <i>Salix sitchensis</i>      | Sitka willow      | FACW                          | container/ live stake |

<sup>a</sup> See Table 7.2-4 for indicator status definitions.



**Black Cottonwood/Willow Zone**

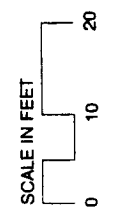


**Red Alder/Salmonberry Zone**

Note: See Appendix E Sheets L5 - L10 for more details

Port of Seattle/Natural Resource Mitigation Plan/556-2912-001/01(03) 9/01 (K)

**Figure 7.3-7  
Typical Planting Plan Example  
for the Black Cottonwood and  
Red Alder Planting Zones**





### Red Alder/Salmonberry Association

The red alder/salmonberry association (Table 7.3-4, Figure 7.3-7) commonly occurs on wet valley floors in seasonally flooded areas (Kunze 1994). This association will be planted above the 42-ft elevation on the east side and above the 47-ft elevation on the west side, where year-round soil saturation would not occur.

Table 7.3-4. Proposed plant species list for the red alder/salmonberry association.

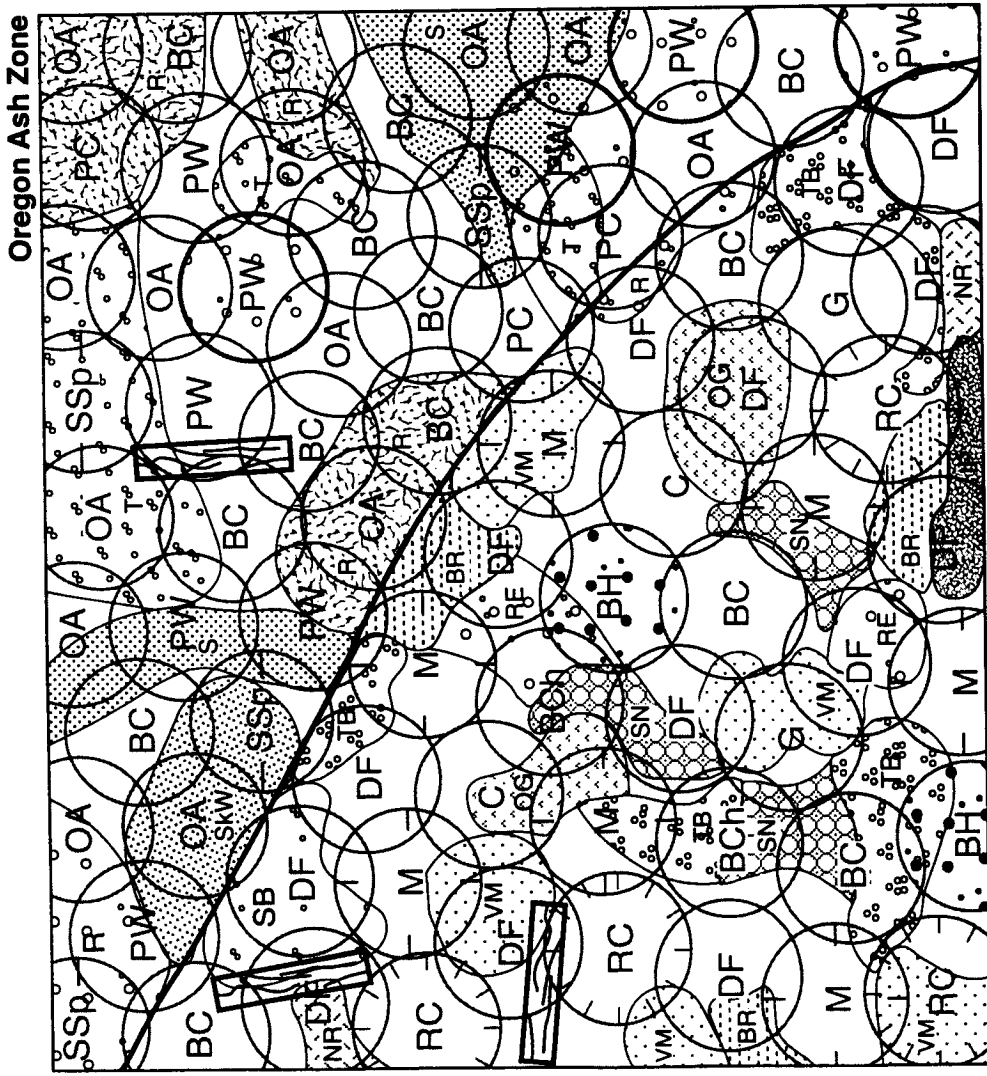
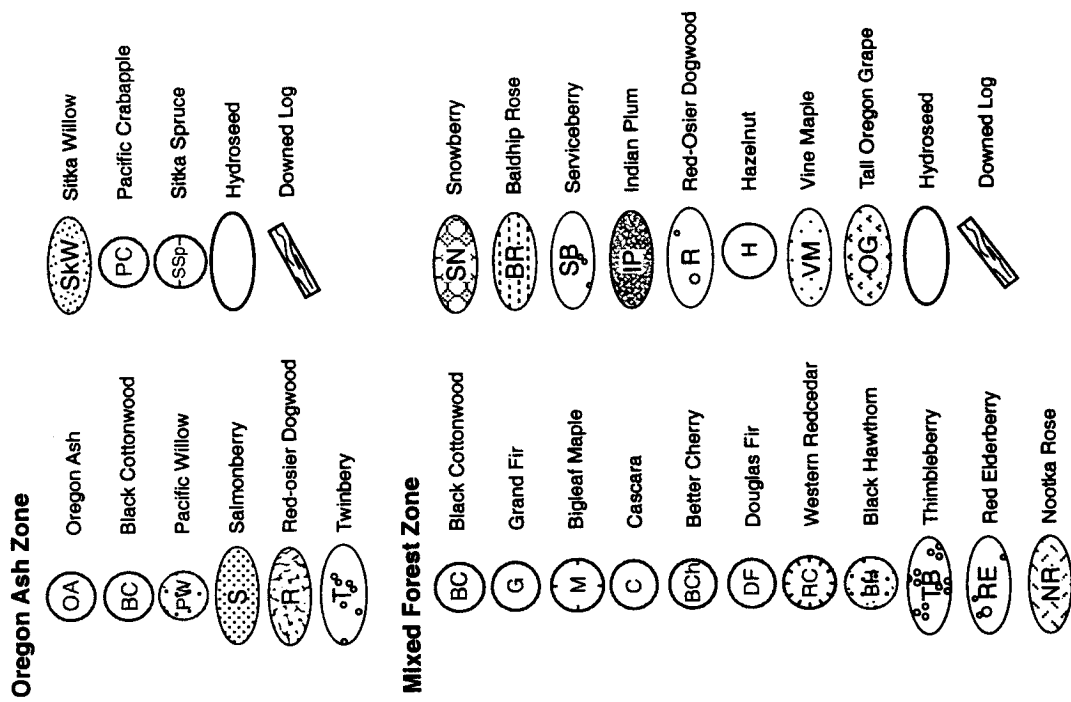
| Scientific Name             | Common Name       | Indicator Status | Condition             |
|-----------------------------|-------------------|------------------|-----------------------|
| <b>Trees</b>                |                   |                  |                       |
| <i>Alnus rubra</i>          | Red alder         | FAC              | container             |
| <i>Fraxinus latifolia</i>   | Oregon ash        | FACW             | container             |
| <i>Malus fusca</i>          | Western crabapple | FACW             | container             |
| <i>Picea sitchensis</i>     | Sitka spruce      | FAC              | container             |
| <i>Populus trichocarpa</i>  | Black cottonwood  | FAC              | container/live stake  |
| <i>Salix lasiandra</i>      | Pacific willow    | FACW+            | container/live stake  |
| <i>Thuja plicata</i>        | Western redcedar  | FAC              | container/ bareroot   |
| <b>Shrubs</b>               |                   |                  |                       |
| <i>Cornus stolonifera</i>   | Red-osier dogwood | FACW             | container/ live stake |
| <i>Lonicera involucrata</i> | Twinberry         | FAC+             | container             |
| <i>Rosa nutkana</i>         | Nootka rose       | FAC              | container             |
| <i>Rubus spectabilis</i>    | Salmonberry       | FAC+             | container             |
| <i>Salix scouleriana</i>    | Scouler's willow  | FAC              | container/ live stake |

### Oregon Ash Association

The Oregon ash association is most commonly found in floodplains or associated with streams and backwater sloughs (Kunze 1994). This community will be planted in the wetter portions of the forest zone, since most of the associated species are tolerant of soil saturation and inundation well into the spring. Oregon ash will comprise most of the canopy cover, with salmonberry and willow in the shrub layer (Table 7.3-5; Figure 7.3-8).

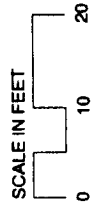
Table 7.3-5. Proposed plant species list for the Oregon ash association.

| Scientific Name             | Common Name       | Indicator Status | Condition             |
|-----------------------------|-------------------|------------------|-----------------------|
| <b>Trees</b>                |                   |                  |                       |
| <i>Fraxinus latifolia</i>   | Oregon ash        | FACW             | container             |
| <i>Malus fusca</i>          | Western crabapple | FACW             | container             |
| <i>Picea sitchensis</i>     | Sitka spruce      | FAC              | container/bareroot    |
| <i>Populus trichocarpa</i>  | Black cottonwood  | FAC              | container/ live stake |
| <i>Salix lasiandra</i>      | Pacific willow    | FACW+            | container/ live stake |
| <b>Shrubs</b>               |                   |                  |                       |
| <i>Cornus stolonifera</i>   | Red osier dogwood | FACW             | container/live stake  |
| <i>Lonicera involucrata</i> | Twinberry         | FAC+             | container             |
| <i>Rubus spectabilis</i>    | Salmonberry       | FAC+             | container             |
| <i>Salix stichensis</i>     | Sitka willow      | FACW             | container/live stake  |



Note: See Appendix E Sheets L5 - L10 for more details

**Figure 7.3-8  
Typical Planting Plan  
for the Oregon Ash and  
Mixed Forest Planting Zones**



Port of Seattle/Natural Resource Mitigation Plan 556-2912-001/01(03) 9/01 (R)

### Mixed Forest Association

The mixed forest association includes several coniferous and deciduous tree species as well as an understory shrub component. Some of the tree species in this association are not tolerant of prolonged saturation. Therefore, this association will be planted in the upper zone between wetland and upland, as well as in the upland buffers (Table 7.3-6; see Figure 7.3-8).

Table 7.3-6. Proposed plant species list for the mixed forest association.

| Scientific Name              | Common Name       | Indicator Status | Condition            |
|------------------------------|-------------------|------------------|----------------------|
| <b>Trees</b>                 |                   |                  |                      |
| <i>Abies grandis</i>         | Grand fir         | FACU-            | container            |
| <i>Acer macrophyllum</i>     | Big-leaf maple    | FACU             | container            |
| <i>Alnus rubra</i>           | Red alder         | FAC              | container            |
| <i>Crataegus douglasii</i>   | Black hawthorn    | FAC              | container            |
| <i>Populus trichocarpa</i>   | Black cottonwood  | FAC              | container/ bare root |
| <i>Prunus emarginata</i>     | Bitter cherry     | FACU             | Container            |
| <i>Psuedotsuga menziesii</i> | Douglas fir       | FACU             | container            |
| <i>Rhamnus purshiana</i>     | Cascara           | FAC-             | container            |
| <i>Thuja plicata</i>         | Western redcedar  | FAC              | container            |
| <b>Shrubs</b>                |                   |                  |                      |
| <i>Acer circinatum</i>       | Vine maple        | FAC-             | container            |
| <i>Amelanchier alnifolia</i> | Serviceberry      | FACU             | container            |
| <i>Mahonia aquilifolium</i>  | Tall Oregon grape | FACU             | container            |
| <i>Corylus cornuta</i>       | Hazelnut          | FACU             | container            |
| <i>Oemleria cerasiformis</i> | Indian plum       | FACU             | container            |
| <i>Rosa gymnocarpa</i>       | Bald-hip rose     | FACU             | container            |
| <i>Rosa nutkana</i>          | Nootka rose       | FAC              | container            |
| <i>Rubus parviflorus</i>     | Thimbleberry      | FAC-             | container            |
| <i>Sambucus racemosa</i>     | Red elderberry    | FACU             | container            |
| <i>Symphoricarpos albus</i>  | Snowberry         | FACU             | container            |

### Western Redcedar Association

The western redcedar association includes deciduous as well as coniferous tree species, with an understory of FAC and FACW shrub species (Table 7.3-7; Figure 7.3-9). Tree species such as western redcedar and big-leaf maple are not tolerant of prolonged soil saturation. Therefore, this association will be planted in the upper portions of the wetland zone, or above approximately elevation 47 ft in the west basin and about 44 ft in the east basin.

**Table 7.3-7. Proposed plant species list for the western redcedar association.**

| Scientific Name              | Common Name      | Indicator Status | Condition             |
|------------------------------|------------------|------------------|-----------------------|
| <b>Trees</b>                 |                  |                  |                       |
| <i>Abies grandis</i>         | Grand fir        | FACU-            | container/ bareroot   |
| <i>Acer macrophyllum</i>     | Big-leaf maple   | FACU             | container             |
| <i>Alnus rubra</i>           | Red alder        | FAC              | container             |
| <i>Populus trichocarpa</i>   | Black cottonwood | FAC              | container/ bareroot   |
| <i>Rhamnus purshiana</i>     | Cascara          | FAC-             | container             |
| <i>Thuja plicata</i>         | Western redcedar | FAC              | container             |
| <b>Shrubs</b>                |                  |                  |                       |
| <i>Acer circinatum</i>       | Vine maple       | FAC-             | container             |
| <i>Oemleria cerasiformis</i> | Indian plum      | FACU             | container             |
| <i>Physocarpus capitatus</i> | Pacific ninebark | FACW-            | container             |
| <i>Salix scouleriana</i>     | Scouler's willow | FAC              | container/ live stake |

### **Existing Wetland Enhancement**

The existing emergent wetlands will be enhanced by planting them with various forested and shrub communities, including black cottonwood/willow, red alder/salmonberry, Oregon ash, and willow/red osier dogwood plant associations (see Tables 7.3-3 through 7.3-5 and 7.3-8). Trees and shrubs included in these associations will be infill-planted into the existing wetland vegetation. Wetland enhancement communities will be planted at the existing ground elevations, between elevations 45 and 49 ft.

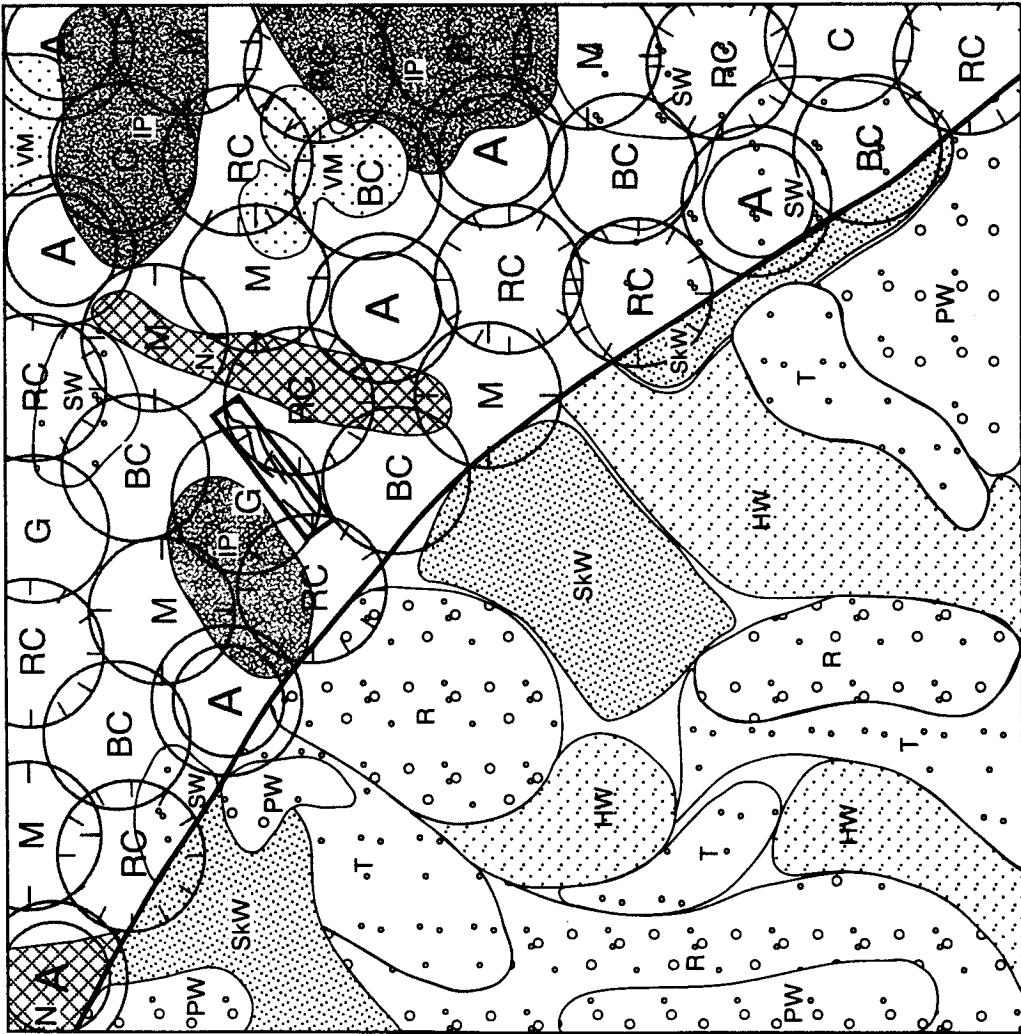
### **Forest Buffers**

A 100-ft forested buffer along its boundaries will protect the mitigation site from off-site disturbance and provide additional wildlife habitat. In addition, upland forest between the existing wetland and the newly created wetlands will create an upland/wetland mosaic to increase habitat diversity (Appendix E, Sheets L5 through L10). Approximately 15.9 acres of forested buffer and upland will be established.

Buffer areas on the site range from moist upland areas to wetter transitional areas between uplands and wetlands. Transitional areas between uplands and wetlands will be planted with the western redcedar association (see Table 7.3-7), while upland areas will be planted with the mixed forest association (see Table 7.3-6).

Upland areas disturbed during wetland construction will be seeded using a mix of low-growing grass species (see Table 7.3-2) prior to planting. Trees and shrubs will be planted at densities sufficient to attain the stem density and canopy cover performance standards identified for forested wetland habitat (see Table 7.1-2).

Western Redcedar Zone



Willow/Red Osier Dogwood Shrub Zone

Western Redcedar Zone

- G Grand Fir
- M Bigleaf Maple
- RC Western Redcedar
- BC Black Cottonwood
- A Red Alder
- C Cascara
- VM Pacific Ninebark
- IP Indian Plum
- SW Scouler's Willow
- PW Pacific Ninebark
- VM Vine Maple
- IP Indian Plum
- Hydroseeding
- Downed Log

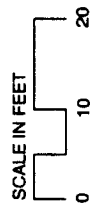
Shrub Zone

- R Red-Osier Dogwood
- HW Hooker's Willow
- T Twinberry
- PW Pacific Willow
- SKW Sitka Willow
- Hydroseeding

Note: See Appendix E Sheets L5 - L10 for more details

Figure 7.3-9  
Typical Planting Plan  
for the Western Redcedar  
and Shrub Planting Zones

Port of Seattle/Natural Resource Mitigation Plan/556-2912-001/01(03) 9/01 (K)



### 7.3.4.2 Shrub Wetland Community

#### Willow/Red Osier Dogwood Association

The shrub wetlands will be planted with a willow/red osier dogwood association (Table 7.3-8, see Figure 7.3-9). Shrubs will be planted approximately 4 to 6 ft on-center. This association will occupy wetter areas of the site that are inundated during the winter months and have saturated soils into the summer. Shrub wetlands will be planted between elevation 44 and 47 ft in the west basin, and between 41 and 42 ft in the east basin (Appendix E, Sheets L5 through L10).

**Table 7.3-8. Proposed plant species list for the willow/red osier dogwood shrub zone.**

| Scientific Name             | Common Name       | Indicator Status | Condition                | Comments                                                                                                           |
|-----------------------------|-------------------|------------------|--------------------------|--------------------------------------------------------------------------------------------------------------------|
| <i>Cornus stolonifera</i>   | Red-osier dogwood | FACW             | container/<br>live stake | Shrubs will be planted in approximately 85% to 90% of the shrub zone at spacings ranging from 5 to 8 ft on-center. |
| <i>Lonicera involucrata</i> | Twinberry         | FAC+             | container                |                                                                                                                    |
| <i>Salix hookeriana</i>     | Hooker's willow   | FACW-            | container/<br>live stake |                                                                                                                    |
| <i>Salix lasiandra</i>      | Pacific willow    | FACW+            | container/<br>live stake |                                                                                                                    |
| <i>Salix sitchensis</i>     | Sitka willow      | FACW             | container/<br>live stake |                                                                                                                    |

### 7.3.4.3 Emergent Wetland Community

Emergent wetlands in the excavated basins will be planted with native emergent species common in the Green River valley and the northern Puget Sound region. Since wetland hydrology is designed to create both seasonally and permanently flooded areas, plants that are tolerant of extended flooding and soil saturation will be established in these areas. The emergent zones will be planted with an herbaceous community dominated by native sedge and rush species such as beaked sedge, slough sedge, water parsley, small-fruited bulrush, and narrow-leaved bur-reed (Table 7.3-9; Figure 7.3-10; Appendix E, Sheets L5 through L10). Emergent communities will be planted in the wettest portions of the site with year-round soil saturation and some areas of permanent standing water. Emergent communities will be planted below between elevation 42 and 44 ft in the west basin between 38 and 41 ft in the east basin.

Where emergent marsh plants are specified, they will be planted with rhizomes or stems spaced 12 inches on center. Areas that are designated for hydroseeding but have visible surface water on them at the time of planting will be planted with marsh plants (rhizomes, rooted stems/seedlings, plugs, etc.

**Table 7.3-9. Proposed species list for the beaked sedge/water parsley emergent zone.**

| Scientific Name             | Common Name           | Indicator Status | Condition      |
|-----------------------------|-----------------------|------------------|----------------|
| <i>Carex rostrata</i>       | Beaked sedge          | OBL              | plug/container |
| <i>Eleocharis palustris</i> | Common spike-rush     | OBL              | plug/container |
| <i>Oenanthe sarmentosa</i>  | Water parsley         | OBL              | container      |
| <i>Polygonum amphibium</i>  | Water smartweed       | OBL              | container      |
| <i>Scirpus acutis</i>       | Hardstem bulrush      | OBL              | plug/container |
| <i>Scirpus microcarpus</i>  | Small-fruited bulrush | OBL              | plug/container |
| <i>Sparganium emersum</i>   | Narrow-leaf bur-reed  | OBL              | plug/container |

The typical growth pattern for emergent marsh plants is in monotypic patches with some interspersions in open, less densely vegetated areas, and proposed planting would mimic this pattern (Figure 7.3-10). Planting shoots with rhizomes 12 inches on-center in monotypic stands of varying size, in combination with seeding a mix of emergent species (see Table 7.3-2) in the areas between patches, should achieve that result. Because ponding in emergent areas is expected well into the early summer, planting of emergent species will occur during the fall months when soils are becoming saturated, but before water levels reach their winter maximum.

## **7.4 IMPLEMENTATION**

The following sections describe the general implementation sequence for the Auburn site. Table 7.4-1 presents a proposed implementation timeline for Auburn mitigation projects.

### **7.4.1 Pre-construction Meeting**

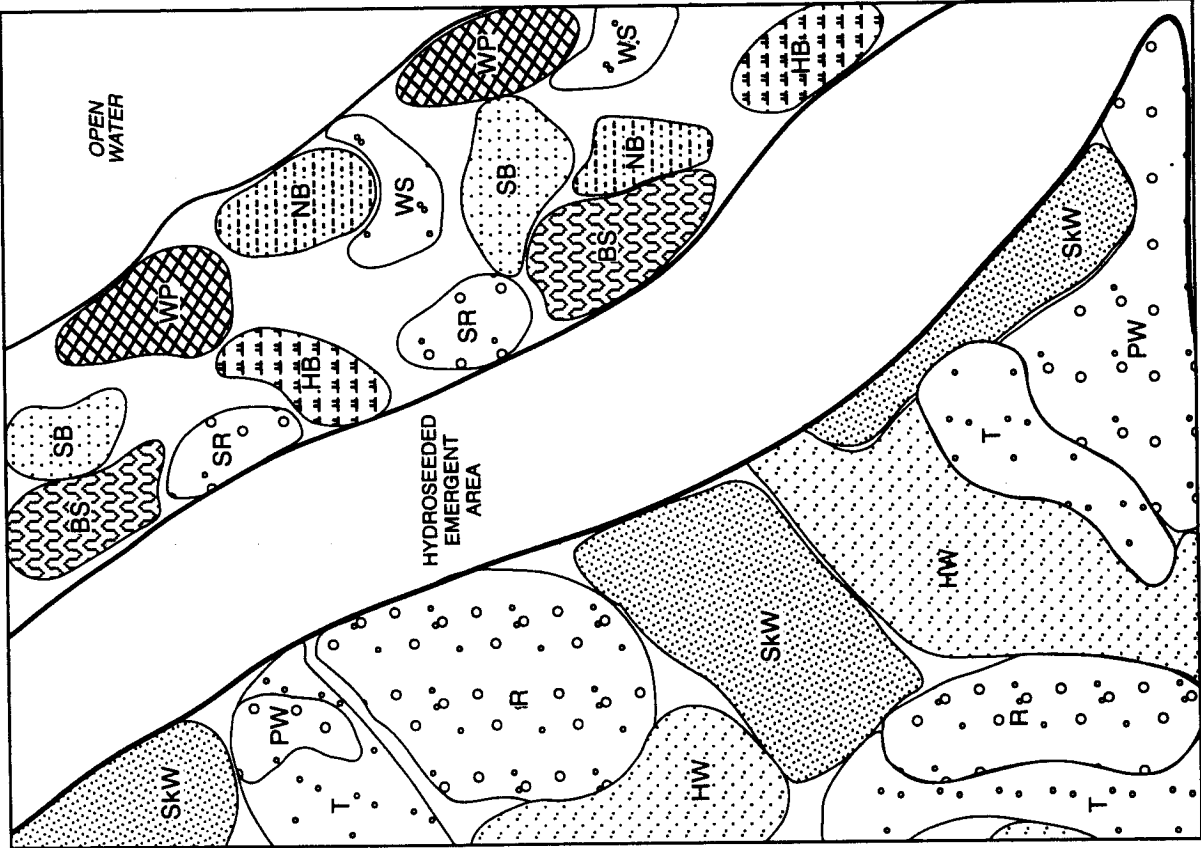
Oversight during construction of the wetland mitigation will be required to ensure that the contractors follow the plans and specifications. Prior to any site work, a pre-construction meeting will be held with the Port, general contractors, engineers, landscape contractors, landscape architects, and biologists to ensure that the work is constructed as designed, and that contractors understand and comply with all environmental permit conditions. Both a civil engineer and wetland ecologist will be available for on-site inspections and approval of all work during construction.

### **7.4.2 Site Preparation and Planting**

#### **7.4.2.1 Existing Wetlands**

The majority of the existing wetlands will not be cleared of vegetation or graded during site grading and excavation (Appendix E, Sheets C3 through C6). Non-native vegetation in the existing wetlands will be managed before installing native plants to reduce competition, and to control weeds. Management will include reducing cover and vigor of existing non-native vegetation. Plant installation will occur between March and October, and weed management should occur immediately prior to installing plants.

**Emergent Zone**



- Emergent Zone**
- Beaked Sedge
  - Water Parsley
  - Common Spike-Rush
  - Water Smartweed
  - Hardstem Bulrush
  - Small-fruited Bulrush
  - Narrow-leaf Bur-reed
  - Hydroseed Mix/  
Natural Colonization

- Shrub Zone**
- Red-Osier Dogwood
  - Hooker's Willow
  - Twinberry
  - Pacific Willow
  - Sitka Willow
  - Hydroseeding

Note: See Appendix E Sheets L5 - L10 for more details

Port of Seattle/Natural Resource Mitigation Plan/556-2912-001/01(03) 901 (K)



**Figure 7.3-10  
Typical Planting Plan  
for the Emergent and  
Shrub Planting Zones**



Table 7.4-1. Proposed implementation timeline for Auburn wetland mitigation projects.

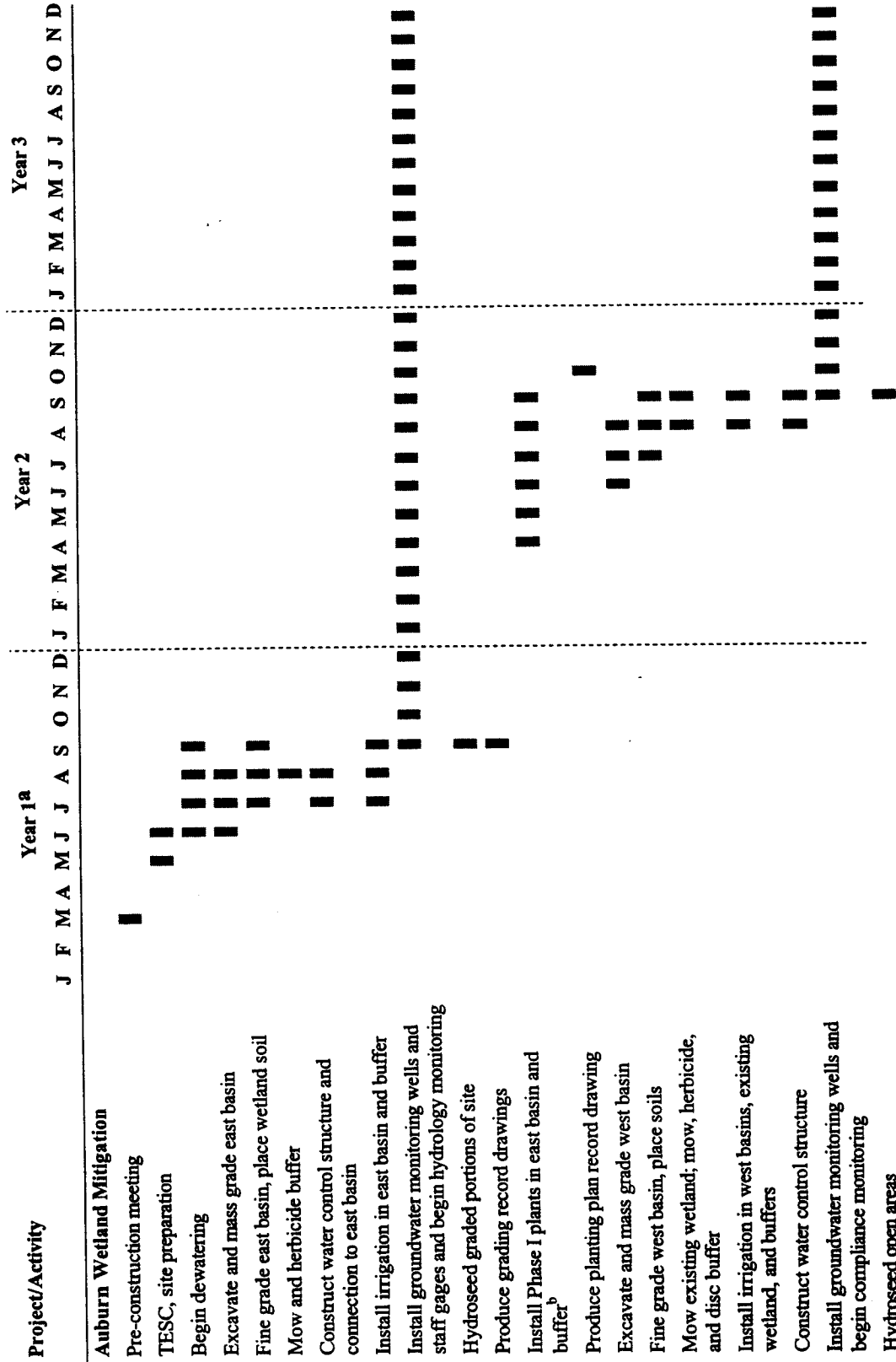


Table 7.4-1. Proposed implementation timeline for Auburn wetland mitigation projects (continued).

| Project/Activity                                                                   | Year 1 <sup>a</sup> |   |   |   |   |   |   |   |   |   |   |   | Year 2 |   |   |   |   |   |   |   |   |   |   |   | Year 3 |   |   |   |   |   |   |   |   |   |   |   |
|------------------------------------------------------------------------------------|---------------------|---|---|---|---|---|---|---|---|---|---|---|--------|---|---|---|---|---|---|---|---|---|---|---|--------|---|---|---|---|---|---|---|---|---|---|---|
|                                                                                    | J                   | F | M | A | M | J | J | A | S | O | N | D | J      | F | M | A | M | J | J | A | S | O | N | D | J      | F | M | A | M | J | J | A | S | O | N | D |
| Produce grading and irrigation record drawings                                     |                     |   |   |   |   |   |   |   |   |   |   |   |        |   |   |   |   |   |   |   |   |   |   |   |        |   |   |   |   |   |   |   |   |   |   |   |
| Install Phase I plants in west basin, existing wetland, and buffers                |                     |   |   |   |   |   |   |   |   |   |   |   |        |   |   |   |   |   |   |   |   |   |   | ■ | ■      | ■ | ■ | ■ | ■ | ■ | ■ | ■ | ■ | ■ | ■ |   |
| Closeout of temporary access roads, staging areas                                  |                     |   |   |   |   |   |   |   |   |   |   |   |        |   |   |   |   |   |   |   |   |   |   | ■ | ■      |   |   |   |   |   |   |   |   |   |   |   |
| Produce planting plan record drawings, conduct baseline monitoring for entire site |                     |   |   |   |   |   |   |   |   |   |   |   |        |   |   |   |   |   |   |   |   |   |   | ■ | ■      | ■ | ■ | ■ | ■ | ■ | ■ | ■ | ■ | ■ | ■ |   |
| Begin compliance monitoring <sup>c</sup>                                           |                     |   |   |   |   |   |   |   |   |   |   |   |        |   |   |   |   |   |   |   |   |   |   |   |        |   |   |   |   |   |   |   |   |   |   |   |

<sup>a</sup> Year one starts with the first construction season following issuance of permits. Implementation of mitigation projects may vary from this proposed schedule depending upon coordination with other Master Plan Update projects, contract obligations, or final approval.  
<sup>b</sup> Plant procurement for all projects will be implemented 6 to 12 months prior to the anticipated planting date to ensure that plants in the specified quantities and species are available by the scheduled planting date. Sensitive coniferous species will be planted in a Phase II planting to occur 3 years following the initial planting.  
<sup>c</sup> Compliance monitoring begins once grading is complete.

Prior to the scheduled plant installation in the existing wetlands, existing vegetation will be mowed and maintained at a maximum height of approximately 6 to 12 inches. Enhancement plantings will be installed per the planting schedule (Appendix E, Sheets L5 through L10). Native trees and shrubs will be installed in clumps of 5 to 10 individuals. Mowing may occur periodically to maintain the grasses at a height of 12 inches or less. Mowing between the planted areas may be necessary for the first 3 to 5 years of the monitoring period to minimize competition between the planted stock and existing pasture grasses or to control invasive plants.

This weed management strategy is expected to maximize the success of plant establishment. Over time, the areas in between the planted clumps will fill in with native wetland trees and shrubs through the increase in cover from the initial planted stock, as well as colonization of new areas.

#### **7.4.2.2 Protective Buffers**

Buffers at the Auburn site will be established in a 100-ft-wide zone around the perimeter of the mitigation site, as well as in the areas between the existing wetlands and newly created wetlands (Appendix E, Sheets C3 through C6). The existing upland areas, including the buffer around the wetlands, are currently dominated by non-native pasture grasses and forbs. To reduce competition from existing vegetation and to control weeds prior to planting, the cover of existing vegetation will be reduced, and soils will be disced to prepare a substrate for the hydroseed mix and the planted stock. During early to mid summer, existing vegetation will be mowed to a maximum height of approximately 6 to 12 inches. The vegetation will be allowed to grow for about 2 weeks to produce new shoots and leaves, and then herbicide will be applied per the specifications. Approximately 2 weeks after the herbicide application, the area will be thoroughly disced to mix the upper soil profile, irrigation will be installed, and a hydroseed mix applied. The following spring and summer, plants will be installed in the buffer planting zones.

#### **7.4.3 Erosion Control**

Prior to any site preparation and grading, sediment and erosion control measures will be implemented to protect on- and off-site aquatic systems from sedimentation. Generally, construction of the wetland basins will not be prone to off-site migration of sediments due to the level topography of the site and the lack of surface water features in or adjacent to the site. In areas where fine sediments could potentially occur in surface waters, adjacent properties, or existing wetlands due to construction activities, a variety of erosion control measures will be employed. Staging areas and existing wetlands will be protected with silt fencing. Stockpiled soil left in place for more than 3 weeks will be stabilized with an approved native hydroseed mixture, tarp, or appropriate BMP. In addition, a native erosion control grass seed mixture will be used to stabilize the soil in the graded portions of the site until native vegetation can be installed.

To reduce tracking of mud onto paved roads, the site entrance roads will be stabilized using a pad constructed of quarry spalls. Vehicles and/or their tires will be washed or brushed prior to leaving the site during periods when track-out of mud could occur.

#### **7.4.4 Excavation and Grading**

Prior to excavation and grading, the extent of all grading activities will be surveyed by a professional surveyor and staked in the field. The contractor will establish vertical and horizontal site controls and maintain them throughout the construction period. The limits of work will be identified and flagged in the field, wetlands and surface water features will be identified with orange barrier fencing, and the TESC measures will be installed.

Approximately 440,000 cy of soil will be excavated to form the new wetland basins to the east and west of the existing wetlands. The top 12 inches of soil will be stripped and removed from the site. This surface material, as well as the majority of the excavated material, will be transported off site and disposed of at an approved upland location. A portion of the excavated subsoils, which are composed of silts, clays, and fine sands, will be blended with composted organic matter and used as topsoil to be placed after the new site grades are established. The topsoil blending operation will require temporary stockpiling and processing at either an on-site or off-site location.

The existing drainage channel, located north of the site, will be widened to connect the mitigation site with the 100-year floodplain and an existing ditch system near South 277<sup>th</sup> Street (Appendix E, Sheet C8 Section 5).

Final grading and habitat log placement will be performed under the direction of the wetland scientist or landscape architect. If subsoils have become compacted during preliminary grading, the soil surface will be ripped and/or disced prior to spreading the amended topsoil mix. The topsoil mix will be placed to a depth of at least 12 inches.

#### **7.4.5 Construction Access Roads, Staging Areas, and Maintenance Roads**

In addition to any temporary access and/or haul roads, temporary construction and maintenance roads will be required on the mitigation site. Temporary maintenance roads will be constructed around each wetland basin to provide vehicular access during planting, and for the early site maintenance and monitoring period. Temporary gravel paths will provide foot and small vehicle access to the interior of the site during the planting period.

##### **7.4.5.1 Staging Areas and Temporary Haul and Access Roads**

On completion of earthwork and planting phases, temporary staging areas and access and haul roads will be removed, prepared for planting, and planted. Staging areas and/or access roads that are not within the mitigation site boundaries will be cleared of construction equipment and debris and soils will then be ripped or disced to break up compacted layers and prepare a suitable substrate for planting. Except for where these areas cross wetland, they will be hydroseeded with the low-grow erosion control seed mix specified for the upland buffers (Table 7.3-2). Where they cross wetlands, the wetland hydroseed mix will be used.

Temporary staging areas or access roads within the mitigation site will be removed and planted. These areas will be cleared of construction equipment and debris, road materials will be removed, and soil surfaces will be prepared for planting and planted according to the planting plan. For

example, where a temporary haul road occurs in an area designated as western redcedar on the planting plans (Appendix E, Sheets L5 through L8), the area will be planted with the western red cedar association once the road is removed. Preparation of these areas for planting may include deep ripping or discing, depending on the degree of soil compaction, and the addition of organic mulch.

#### **7.4.5.2 Gravel Paths and Maintenance Roads**

Temporary gravel paths in the mitigation area will provide access for planting, initial maintenance, and monitoring. These access paths and roads will help assure that:

- The initial planting can be readily completed in a reasonable timeframe.
- If phased plantings are desired, latter phases can be implemented without damaging plants installed in previous phases.
- If replacement plantings are needed, they can be installed without damaging other vegetation.

The gravel paths will be decommissioned after five complete growing seasons following completion of planting if the areas have met plant cover and survival performance standards for 2 consecutive years. If the areas are not meeting cover performance standards at the end of 5 years, the gravel paths will be decommissioned when basins have met plant cover and survival performance standards. Decommissioning will include removing path materials, preparing the soil surface for planting (e.g., ripping and/or tilling), and planting according to the planting plan.

The temporary maintenance roads will be removed after five growing seasons if the areas they serve meet cover performance standards for 3 consecutive years. The road materials will be removed and soil surfaces treated to provide a suitable medium for plant growth (i.e., ripping and/or discing). The road area will be planted with fast-growing species from the mixed forest plant schedule (i.e., Douglas fir, red alder, black cottonwood, bald-hip rose).

Maintenance roads along the west, north, and south sides of the site may be retained throughout the 15-year monitoring period for maintenance and security for the site (i.e., to manage weed control, support any necessary replanting, prevent dumping, etc.). At the end of the 15-year monitoring period, the Port will consult with regulatory agencies to determine if the maintenance roads should be decommissioned, or if they should be retained to allow for on-going maintenance, adaptive management, or security needs. If it is determined the maintenance roads should be removed, they will be planted as described above for the construction haul and access roads.<sup>52</sup>

---

<sup>52</sup> If the maintenance roads were left in place, the canopies of adjacent trees would cover the road. There would be a minor reduction in habitat for small mammals and ground nesting birds. According to Ecology (1999) infrequently used gravel or paved roads can be ignored as a disturbance (see data sheets for Riverene Flow through wetlands)

#### **7.4.6 Temporary Irrigation**

After all grading activities have been completed a temporary irrigation system will be installed throughout the site. Installation of the temporary irrigation system will be coordinated with grading and planting steps to ensure that irrigation is installed prior to plant installation. Installation of the temporary irrigation system will be below ground in all areas that will be cleared and graded; however, the system will be installed above ground in the existing wetlands.

The temporary irrigation system will remain in place and functional until the plants become established, which is anticipated to take 2 to 5 years (depending on any phasing requirements or needs to replant to meet 80 percent survival requirements).<sup>53</sup> The temporary systems will be decommissioned and above-ground parts of the system will be removed. The below-ground lines will be abandoned in place to prevent any need for soil or vegetation disturbance from equipment and pipe removal.

#### **7.4.7 Establish Native Wetland and Upland Buffer Vegetation**

All planting zone boundaries will be surveyed by a professional surveyor, and staked and flagged in the field according to the planting plan. A landscape architect or wetland scientist will observe plant installation to ensure that plants are installed properly and according to the plans and specifications. The contractor will be responsible for ensuring that plants are not damaged during transport, staging, or installation, and will be responsible for plant survival and health during the first year following planting.

Due to the large number of plants required to cover the entire buffer, planting may occur in phases. An initial planting of rapidly growing plants tolerant of full sun will be followed by a second planting of more slowly growing species that tolerate or require shade. Planting activities will most likely occur during the spring and fall months to avoid potential disturbance to wintering bald eagles in the vicinity of the Green River.

To further protect the site from people and pets, the fence line will be densely planted with species from the mixed forest community type to provide a physical and visual screen. Dense planting along the fence line will include Douglas fir, black hawthorn, tall Oregon grape, bald-hip rose, and big-leaf maple (Appendix E, Sheet L10, Detail 6).

#### **7.4.8 Record Report and Monitoring**

On completion of earthwork, site topography will be surveyed and a report containing record drawings for the earthwork phase will be prepared and submitted to regulatory agencies. The planting plan will be reviewed and adjusted if necessary to match constructed grades and site conditions. Adjustments may include moving the boundaries of planting zones or adjusting species compositions to ensure successful establishment of the plant communities. Any necessary

---

<sup>53</sup> Use of temporary irrigation during the establishment phase follows wetland mitigation design recommendations of King County (Mockler 1999b) and Ecology (personal communication with Erik Stockdale, February 2000) for improving the success of mitigation projects.

adjustments to the planting plan will be submitted to regulatory agencies with the earthwork record drawings and report.

Upon completion of planting (i.e., completion of all planting phases), a complete set of record drawings (including both earthwork and planting record drawings) documenting the constructed mitigation site will be prepared and submitted to regulatory agencies. Baseline monitoring (year 0 monitoring) will be conducted on completion of planting to document baseline ecological conditions on the site. Compliance monitoring consistent with the monitoring plan outlined in Section 4 of this document will begin during the first growing season after submittal of the complete set of record drawings (i.e., monitoring year 1). Monitoring reports will be submitted to the regulatory agencies consistent with the schedule described in Section 4 of this document.

#### **7.4.9 Construction Steps**

The following sections provide a general outline of the construction and post-construction steps necessary to implement the mitigation plan.

##### **7.4.9.1 General Conditions**

- All site work will be consistent with permit conditions and City of Auburn grading permit.
- A pre-construction meeting will be held with contractor, architect/engineer, and wetland scientist to review submittals, work plan, schedules, and permit conditions.
- The contractor will be responsible for ensuring that the work is performed in accordance with all permit conditions and shall maintain a copy of permits on site.
- During construction, hydroseed or mulch will be applied to all open areas after grading consistent with City of Auburn grading permit.
- All areas of exposed soil will be hydroseeded or mulched by September 15<sup>th</sup> to stabilize the site prior to the start of the rainy season.
- Plant procurement must be coordinated with the construction schedule to ensure that specified plant quantities and species are available when they are needed.

##### **7.4.9.2 Site Preparation**

- Establish and maintain vertical and horizontal site controls throughout the construction period.
- Identify and flag limits of work for the mitigation site.
- Install fencing (orange barrier) around existing wetlands and outlet ditches.
- Implement TESC plan.
- Maintain security of the site through construction; install security fence around site.
- Establish temporary site access roads and wetland crossings.
- Establish staging and stockpile areas.

- Implement a spill control plan and identify fueling areas.
- Install dewatering system (pumping wells, manifold piping, and discharge structure).
- Install temporary utilities (e.g., electric power and irrigation mains).

#### **7.4.9.3 Outlet Channel and Outlet Control Structure**

- Install temporary sediment and erosion control measures.
- Recontour ditch at the north end of site (as needed), construct water control structure and channel connecting to the east wetland basin.
- Install erosion control matting and hydroseed open areas.
- Install outlet control structure.

#### **7.4.9.4 East Wetland Basin and Buffer**

- Clear site of brush and fence, etc.
- Strip top 12 inches of soil material and dispose of off site in an approved upland disposal area.
- Start dewatering activities.
- Excavate east side of wetland basin.
- Mix subsoils with organic compost and stockpile; stabilize consistent with grading permit requirements.
- Complete fine grading of east side of wetland basin.
- Disc soils that are compacted by grading.
- Place amended soils 12 inches deep over entire east side basin and disc into subsoils.
- Mow existing vegetation in upland buffer areas.
- Install habitat logs and snags.
- Install irrigation system in east basin; restore disturbed grades as needed.
- Install irrigation in upland buffer.
- Test irrigation system.
- Install erosion control matting as needed.
- Remove haul roads, access roads, dewatering ponds/pipes, staging areas, etc. not needed for planting of the existing wetland or west basins, return staging areas/access roads, etc. to grade.
- Apply hydroseed to east basin (wet and transition seed mixes) and upland buffer (low-grow mix) per specifications.
- Winterize irrigation system.



- Produce grading record drawings.
- After grading is complete, install plants in east basin; phase planting if necessary.
- Install plants in upland buffer and in the area between the maintenance roads and the fencing.

#### **7.4.9.5 Preparation and Enhancement Planting of Existing Wetland and Buffer**

- Mow existing vegetation in wetland and buffer.
- Disc and install irrigation in the buffer area only.
- Hydroseed buffer with transition seed mix.
- Install above-ground irrigation in existing wetland.
- Install additional plants in the existing wetland and surrounding buffer areas.
- Perform maintenance mowing in areas between enhancement plantings in the existing wetland.

#### **7.4.9.6 West Wetland Basin**

- Clear site of brush and fence, etc.
- Strip top 12 inches of soil material and dispose of off site in an approved upland disposal area.
- Start dewatering activities.
- Excavate west side wetland basin.
- Mix subsoils with organic compost and stockpile; stabilize consistent with grading permit requirements.
- Complete fine grading of west side basin.
- Disc soils that are compacted by grading.
- Place amended soils 12 to 24 inches deep over entire west side basin.
- Mow existing vegetation in upland buffer areas.
- Install irrigation system and restore disturbed grades as needed.
- Test irrigation system.
- Install habitat logs.
- Install erosion control matting as needed.
- Apply hydroseed to west basin (wet and transition seed mixes) and upland buffer (low-grow seed mix) per specifications.
- Winterize irrigation system.
- Produce grading record drawing (“as-built”).

- After grading is complete, install plants.

#### **7.4.9.7 Closeout**

- Remove temporary haul/access roads.
- Remove construction equipment and debris.
- Hydroseed and/or install plants in temporary staging areas or access roads within the mitigation site boundaries.
- Hydroseed erosion control mix in temporary staging areas/access roads outside the mitigation boundaries.

#### **7.4.9.8 Record Drawings, Monitoring, and Maintenance**

- Produce irrigation and plant installation record drawings (“as-builts”).
- Conduct baseline monitoring and complete baseline report, including record drawings, results of baseline monitoring, and final monitoring plan (e.g., locations of monitoring plots, baseline conditions).
- Begin compliance monitoring after grading is complete; submit annual monitoring reports for 15-year monitoring period.
- Conduct maintenance (e.g., weed management) and implement any necessary contingency measures to meet performance standards.

### **7.5 MONITORING AND PERFORMANCE STANDARDS**

The mitigation site will be monitored for a 15-year period, focusing on collecting the physical and biological data necessary to determine if the performance standards, and ultimately the ecological benefits, of the mitigation are met (see Table 7.1-2). Monitoring reports will summarize the ecological condition of the site and document compliance with performance standards. If necessary, specific contingency actions and schedules for implementing contingency measures will be recommended. The first phase of monitoring will be to complete record drawings and a baseline monitoring report, as described below in Section 7.5.1. Section 7.5.2 describes specific monitoring activities and schedules for the mitigation site.

#### **7.5.1 Record Drawings and Baseline Monitoring Report**

Conditions on the mitigation site following completion of construction will be documented with record drawings and a baseline monitoring report. This report will verify that mitigation has been constructed as designed or document any deviations from the plan. Any significant deviations from the mitigation design will be noted, and submitted to ACOE for approval. The baseline report will also include documentation of all sampling locations for future monitoring activity. A detailed map of the site will be prepared from field surveys, and will include the following information:

- Site topography at 1-ft contour intervals and selected spot elevations.
- Locations of major plant community boundaries.

- Locations of surface water and control structures.
- Locations of vegetation transects, photograph points, groundwater wells, staff gages, and other sampling points.

Baseline monitoring data will be collected to provide the basis for evaluating future changes on the mitigation site, consistent with the approach and methods outlined for all Port mitigation projects in Section 4 of this document. Results of the baseline monitoring will be compared to the established design criteria and performance standards for the mitigation site (see Table 7.1-2).

### **7.5.2 15-Year Monitoring Plan**

Monitoring activities during the 15-year monitoring period will focus on collecting vegetation, hydrology, and wildlife data to determine wetland function and performance, and compliance of the mitigation site with the performance standards. The monitoring schedule and methods for the mitigation site are summarized in Table 7.5-1.

#### **7.5.2.1 Vegetation Monitoring**

Vegetation monitoring will measure establishment of native plant communities on the site. The development of native plant communities will be a key indicator of how well wetland and upland functions are being restored and enhanced by the mitigation. Vegetation is also an indicator of wildlife habitat, as well as having a significant influence on hydrologic and water quality functions.

Data describing plant species composition, density, and cover will be collected along permanent vegetation transects or within permanent plots. Walk-through surveys will be made to estimate annual shoot growth, survival rates, and vertical and horizontal vegetation structure. Photographs can provide qualitative documentation of plant community development over time by evaluating variables such as cover, species composition, height, and vertical structure. Therefore, photographs will be taken along transects and at appropriate viewpoints to document the extent and nature of plant cover. Results of the vegetation monitoring will be used to determine if performance standards for plant survival, cover, density, and species composition are met in each monitoring year.

#### **7.5.2.2 Hydrology**

Data on site hydrology will be collected to evaluate the duration and extent of flooding and/or soil saturation in each wetland type on the mitigation site. Both surface and groundwater hydrology will be monitored using staff gages or permanent groundwater monitoring wells, and field observations. Wells will be placed within existing wetlands and at representative sites in the newly constructed forested, shrub, and emergent plant communities. Surface water levels at staff gages and depth to groundwater will be recorded monthly for the first 3 years after construction is complete, and at least three times per year thereafter (Table 7.5-1).

The water level control structure will be inspected monthly during the first three years following construction, and three times per year for the remainder of the monitoring period. Adjustments will be made following consideration of whether the current water regime is suitable for the plant zones established and how changes could optimize the water regime for achieving performance standards. Changes to the water regime of the wetlands will not be made without notifying ACOE and Ecology.

Table 7.5-1. Auburn wetland mitigation site monitoring methods and schedule.

| Design Objective          | Performance Standard      | Method                                                                                                                        | Frequency | Wetland Vegetation Zone |   |   |   |   |   |   |   |   |    |    |    |   |   |  |
|---------------------------|---------------------------|-------------------------------------------------------------------------------------------------------------------------------|-----------|-------------------------|---|---|---|---|---|---|---|---|----|----|----|---|---|--|
|                           |                           |                                                                                                                               |           | 0                       | 1 | 2 | 3 | 4 | 5 | 6 | 7 | 8 | 10 | 12 | 15 |   |   |  |
| Forest Wetland Vegetation | In-kind replacement ratio | Aerial photographic or ground-based mapping                                                                                   | May       | X                       | X | X | X | X | X | X | X | X | X  | X  | X  | X | X |  |
|                           | Species composition       | Walk-through surveys and vegetation sampling (plots, transects, or plotless techniques) to document all plant species present | July      | X                       | X | X | X | X | X | X | X | X | X  | X  | X  | X | X |  |
|                           | Plant Survival            | Vegetation sampling                                                                                                           | July      | X                       | X | X | X | X | X | X | X | X | X  | X  | X  | X | X |  |
| Forest Wetland Vegetation | Tree and shrub density    | Measure by plot sampling method along transects                                                                               | July      |                         |   |   |   |   |   | X | X | X | X  | X  | X  | X | X |  |
|                           | Plant growth              | Walk-through surveys to estimate annual shoot growth and survival rates                                                       | July      | X                       | X | X | X | X | X | X | X | X | X  | X  | X  | X | X |  |
|                           | Vegetation structure      | Describe from walk-through surveys, incorporating data from above analysis as available                                       | July      | X                       | X | X | X | X | X | X | X | X | X  | X  | X  | X | X |  |
| Shrub Wetland Vegetation  | In-kind replacement ratio | Aerial photographic or ground-based mapping                                                                                   | May       | X                       | X | X | X | X | X | X | X | X | X  | X  | X  | X | X |  |
|                           | Species composition       | Walk-through surveys to document all plant species present by vegetation sampling (plots, transects, or plotless technique)   | July      | X                       | X | X | X | X | X | X | X | X | X  | X  | X  | X | X |  |
|                           | Plant Survival            | Vegetation sampling                                                                                                           | July      | X                       | X | X | X | X | X | X | X | X | X  | X  | X  | X | X |  |
| Shrub Wetland Vegetation  | Shrub density             | Measure by line-intercept method along transects                                                                              | July      |                         |   |   |   |   |   |   |   |   |    |    |    |   |   |  |
|                           | Plant growth              | Walk-through surveys to estimate annual shoot growth and survival rates                                                       | July      | X                       | X | X | X | X | X | X | X | X | X  | X  | X  | X | X |  |

Table 7.5-1. Auburn wetland mitigation site monitoring methods and schedule (continued).

| Design Objective            | Performance Standard      | Method                                                                                                                            | Frequency                                  | Wetland         |   |   |   |   |   |   |   |   |   |    |    |    |   |  |
|-----------------------------|---------------------------|-----------------------------------------------------------------------------------------------------------------------------------|--------------------------------------------|-----------------|---|---|---|---|---|---|---|---|---|----|----|----|---|--|
|                             |                           |                                                                                                                                   |                                            | Vegetation Zone | 0 | 1 | 2 | 3 | 4 | 5 | 6 | 7 | 8 | 10 | 12 | 15 |   |  |
| Emergent Wetland Vegetation | Vegetation structure      | Describe from walk-through surveys, incorporating data from above analysis as available                                           | July                                       | PSS             | X | X | X | X | X | X | X | X | X | X  | X  | X  | X |  |
|                             | In-kind replacement ratio | Aerial photographic or ground-based mapping                                                                                       | May                                        | PEM             | X | X | X | X | X | X | X | X | X | X  | X  | X  | X |  |
|                             | Species composition       | Walk-through surveys to document all plant species present                                                                        | July                                       | PEM             | X | X | X | X | X | X | X | X | X | X  | X  | X  | X |  |
|                             | Herbaceous plant coverage | Measure by plot sampling method along transects                                                                                   | July                                       | PEM             | X | X | X | X | X | X | X | X | X | X  | X  | X  | X |  |
|                             | Plant growth              | Walk-through surveys to estimate annual shoot growth and survival rates                                                           | July                                       | PEM             | X | X | X | X | X | X | X | X | X | X  | X  | X  | X |  |
| Wetland Hydrology           | Vegetation structure      | Describe from walk-through surveys, incorporating data from above analysis, as available                                          | July                                       | PEM             | X | X | X | X | X | X | X | X | X | X  | X  | X  | X |  |
|                             | Soil saturation           | Depth from the soil surface to groundwater measured at permanent sampling stations in forested, shrub, and emergent wetland zones | Monthly<br>February,<br>June,<br>September | PFO, PSS, PEM   | X | X | X | X | X | X | X | X | X | X  | X  | X  | X |  |
|                             | Surface water depth       | Water depths measured at permanent sampling stations in shrub and emergent wetland zones                                          | Monthly<br>February,<br>June,<br>September | PFO, PSS, PEM   | X | X | X | X | X | X | X | X | X | X  | X  | X  | X |  |
| Wildlife                    | Habitat structure         | Analysis of hydrologic and vegetation data from forested, shrub, and emergent wetlands                                            | February,<br>June                          | PFO, PSS, PEM   | X | X | X | X | X | X | X | X | X | X  | X  | X  | X |  |

Table 7.5-1. Auburn wetland mitigation site monitoring methods and schedule (continued).

| Design Objective     | Performance Standard        | Method                                                                                     | Frequency                     | Wetland Vegetation Zone |   |   |   |   |   |   |   |   |    |    |    |   |   |   |
|----------------------|-----------------------------|--------------------------------------------------------------------------------------------|-------------------------------|-------------------------|---|---|---|---|---|---|---|---|----|----|----|---|---|---|
|                      |                             |                                                                                            |                               | 0                       | 1 | 2 | 3 | 4 | 5 | 6 | 7 | 8 | 10 | 12 | 15 |   |   |   |
|                      |                             | Description of habitat structure from walk-through surveys                                 | June                          | X                       | X | X | X | X | X | X | X | X | X  | X  | X  | X | X | X |
|                      | Wildlife use                | Report wildlife species and activities on site                                             | January, April, June, October | X                       | X | X | X | X | X | X | X | X | X  | X  | X  | X | X | X |
| Long-term Protection | Buffers, adjacent land uses | Description of buffer vegetation and adjacent land uses, including proximity and screening | June                          | X                       | X |   |   |   |   | X |   |   |    |    |    |   |   |   |
|                      |                             | Description of adjacent vegetation and land uses                                           | June                          | X                       |   |   |   |   |   | X |   |   |    |    |    |   |   |   |
|                      |                             | Delineate Wetlands                                                                         | March                         |                         |   |   |   |   |   | X |   |   |    |    |    |   |   |   |

AR 049386

### 7.5.2.3 Wildlife Habitat

Habitat structure (i.e., vegetation types, flooding, etc.) of the mitigation site will be monitored to evaluate whether performance standards are being met. These data will be supplemented with observations of wildlife using the site. Wildlife surveys will be conducted four times per year to record wildlife species and activities on site.<sup>54</sup> A variety of techniques will be used to evaluate wildlife use and wildlife habitat attributes on the site. Techniques described in Ralph and Scott (1981), Ramsey and Scott (1979), and Reynolds et al. (1980) may be used to monitor bird numbers. Techniques described in Olson et al. (1997) may be used to sample pond-breeding amphibians and Corn and Bury (1990) for terrestrial amphibians.

## 7.6 SITE PROTECTION

The Port will execute and file restrictive covenants on the Auburn wetland mitigation site to provide permanent protection for the site. Copies of the restrictive covenants are provided in Appendix F. Language and conditions of these restrictive covenants have been revised to reflect discussions between the Port and ACOE, Ecology, FAA, and USDA-WSD.

The boundaries of the mitigation area and buffers shall be permanently marked with stakes at least every 100 feet or with fencing. The marking shall include signage that clearly indicates that mowing and fertilizer/pesticide applications are prohibited within mitigation areas. The details of fencing and signage are provided in Appendix P.

## 7.7 MAINTENANCE AND CONTINGENCY PLANS

### 7.7.1 Routine Maintenance

Routine maintenance tasks (e.g., maintaining irrigation system, removing trash) and adaptive management/contingency measures (e.g., weed management, replacing plants) will occur during the monitoring period. Routine weed control does not include contingency measures that may be needed to keep invasive species cover below the 10 percent cover standard. These are discussed below under contingency measures.

The mitigation site has been designed to achieve final performance standards without significant ongoing maintenance. The need for maintenance is anticipated to decline during the monitoring period because the mitigation has been designed to be self-sustaining in the long term. Some maintenance will continue for at least as long as the 15-year monitoring period.

Typical maintenance activities will include replacing dead plants and implementing weed control measures. For the first year following planting, the landscape contractor will be responsible for ensuring the health of planted material and for replacing dead or severely stressed plant material. After the first year, the Port will be responsible for maintaining plants and will replace plants as

---

<sup>54</sup> Performance standards do not require wildlife surveys. Wildlife surveys will be conducted to obtain additional information that may be useful in making adaptive management decisions or implementing contingency measures.

needed based on performance standards and consistent with specified contingency measures. To achieve relatively rapid overstory development and structural diversity, trees will be planted closer together than would occur in natural, mature stands, and may be fertilized. At the end of the 15-year monitoring period, some trees may be cut or girdled (these would then be left as woody debris for wildlife habitat) to allow better development of some trees. This management activity will allow the remaining trees adequate space to reach full size, while providing additional microhabitat for animals in the downed or standing woody debris.

### **7.7.2 Contingency Measures**

Contingency measures will be implemented consistent with the adaptive management approach if monitoring results show that specific performance standards are not being met. Specific performance standards and contingency measures for the mitigation site are identified in Table 7.7-1. If conditions arise that have not been identified in this table, they will be evaluated on a case-by-case basis, and discussed with ACOE and Ecology. Based on these discussions, appropriate contingency measures will be developed and implemented.

#### **7.7.2.1 Weed Management**

If needed, a variety of weed control strategies are available to manage non-native invasive species, and these weed control strategies may be used as appropriate throughout the project (see Section 4.3.2.4). Specific control measures will be determined on a case-by-case basis, depending on the extent of the invasive species problem, the invasive species of concern, and the site condition. Steps in weed control may include (listed in order of preference) any of the following:

- Dense plantings of desired species that competitively exclude non-native species.
- Use of mulch in the form of sterile straw or other biodegradable mulch.
- Installation of biodegradable weed barrier cloth.
- Mechanical removal of weeds by using weed whackers, hoeing, or hand-removal.
- Applications of EPA-approved herbicides, as necessary.



needed based on performance standards and consistent with specified contingency measures. To achieve relatively rapid overstory development and structural diversity, trees will be planted closer together than would occur in natural, mature stands, and may be fertilized. At the end of the 15-year monitoring period, some trees may be cut or girdled (these would then be left as woody debris for wildlife habitat) to allow better development of some trees. This management activity will allow the remaining trees adequate space to reach full size, while providing additional microhabitat for animals in the downed or standing woody debris.

### **7.7.2 Contingency Measures**

Contingency measures will be implemented consistent with the adaptive management approach if monitoring results show that specific performance standards are not being met. Specific performance standards and contingency measures for the mitigation site are identified in Table 7.7-1. If conditions arise that have not been identified in this table, they will be evaluated on a case-by-case basis, and discussed with ACOE and Ecology. Based on these discussions, appropriate contingency measures will be developed and implemented.

#### **7.7.2.1 Weed Management**

If needed, a variety of weed control strategies are available to manage non-native invasive species, and these weed control strategies may be used as appropriate throughout the project (see Section 4.3.2.4). Specific control measures will be determined on a case-by-case basis, depending on the extent of the invasive species problem, the invasive species of concern, and the site condition. Steps in weed control may include (listed in order of preference) any of the following:

- Dense plantings of desired species that competitively exclude non-native species.
- Use of mulch in the form of sterile straw or other biodegradable mulch.
- Installation of biodegradable weed barrier cloth.
- Mechanical removal of weeds by using weed whackers, hoeing, or hand-removal.
- Applications of EPA-approved herbicides, as necessary.

Table 7.7-1. Final performance standards, evaluation approach, and contingency measures for the Auburn wetland mitigation project.

| Design Criteria                                                                                                                                                                                                                                                           | Performance Standard                                                                                                                                               | Evaluation Approach                                                                                                                                                   | Contingency Measures                                                                                                                    |
|---------------------------------------------------------------------------------------------------------------------------------------------------------------------------------------------------------------------------------------------------------------------------|--------------------------------------------------------------------------------------------------------------------------------------------------------------------|-----------------------------------------------------------------------------------------------------------------------------------------------------------------------|-----------------------------------------------------------------------------------------------------------------------------------------|
| <b>Excavated Areas (East and West Basins)</b>                                                                                                                                                                                                                             |                                                                                                                                                                    |                                                                                                                                                                       |                                                                                                                                         |
| 1. Use a perched water table to establish wetlands at the approximate final grades of:                                                                                                                                                                                    | Wetland areas will meet the following hydrology <sup>a</sup> criteria:                                                                                             | Measure hydrology using ground water monitoring wells, soil pits, and staff gages.                                                                                    | Modify surface drainage features or control elevations of drainage channels.                                                            |
| <u>East Basin</u>                                                                                                                                                                                                                                                         | In forested areas, soils will be saturated within the upper 12 inches for a minimum of 2 weeks during the growing season <sup>b</sup>                              |                                                                                                                                                                       | Minor grading if necessary.                                                                                                             |
| Below 38 ft in open-water wetland                                                                                                                                                                                                                                         |                                                                                                                                                                    |                                                                                                                                                                       |                                                                                                                                         |
| 38 ft to 41 ft in emergent wetlands                                                                                                                                                                                                                                       |                                                                                                                                                                    |                                                                                                                                                                       |                                                                                                                                         |
| 41 ft to 42 ft in shrub wetlands                                                                                                                                                                                                                                          | In shrub areas, soils will be saturated within the upper 6 inches for a minimum of 6 weeks during the March-November period.                                       |                                                                                                                                                                       |                                                                                                                                         |
| 42 ft to 45 ft in forested wetlands                                                                                                                                                                                                                                       |                                                                                                                                                                    |                                                                                                                                                                       |                                                                                                                                         |
| <u>West Basin:</u>                                                                                                                                                                                                                                                        |                                                                                                                                                                    |                                                                                                                                                                       |                                                                                                                                         |
| Below 42 ft in open-water wetland                                                                                                                                                                                                                                         | In emergent zones, soils will be saturated to the soil surface for 6 months, including at least the period of March through June.                                  |                                                                                                                                                                       |                                                                                                                                         |
| 42 ft to 44 ft in emergent wetlands                                                                                                                                                                                                                                       |                                                                                                                                                                    |                                                                                                                                                                       |                                                                                                                                         |
| 44 ft to 47 ft in shrub wetlands                                                                                                                                                                                                                                          |                                                                                                                                                                    |                                                                                                                                                                       |                                                                                                                                         |
| 47 ft to 49 ft in forested wetlands                                                                                                                                                                                                                                       |                                                                                                                                                                    |                                                                                                                                                                       |                                                                                                                                         |
| 2. Plant five forested wetland plant associations that are similar in composition to naturally occurring plant associations. Use native <sup>c</sup> deciduous and evergreen species such as black cottonwood, Oregon ash, red alder, western redcedar, and Sitka spruce. | Forest wetlands will cover at least 36 acres of the mitigation site.<br><br>Upland forest habitat will be established on at least 15 acres of the mitigation site. | Measured using record surveys, vegetation monitoring, and mapping.<br><br>Verify areas available for vegetation zones on completion of grading and prior to planting. | Replant as necessary to achieve desired vegetation.<br><br>Adjust planting areas to match as-built grades and planned vegetation zones. |
| Forest communities will have a native shrub understory with species such as salmonberry, twinberry, red-osier dogwood, red elderberry, willows, and vine maple.                                                                                                           |                                                                                                                                                                    |                                                                                                                                                                       |                                                                                                                                         |

Table 7.7-1. Auburn Wetland Mitigation Site monitoring methods and schedule (continued).

| Design Criteria                                                                                                                                                                | Performance Standard                                                                                                                                                                                                                                                                                                                                                                                                                                                                                                                                                                                                                                                                                                                                                                                                                                              | Evaluation Approach                                                                                                                                                                                                                                                                                              | Contingency Measures                                                                                                                                                                                                                                                                                                                                                                                                                                                                                                                                                             |
|--------------------------------------------------------------------------------------------------------------------------------------------------------------------------------|-------------------------------------------------------------------------------------------------------------------------------------------------------------------------------------------------------------------------------------------------------------------------------------------------------------------------------------------------------------------------------------------------------------------------------------------------------------------------------------------------------------------------------------------------------------------------------------------------------------------------------------------------------------------------------------------------------------------------------------------------------------------------------------------------------------------------------------------------------------------|------------------------------------------------------------------------------------------------------------------------------------------------------------------------------------------------------------------------------------------------------------------------------------------------------------------|----------------------------------------------------------------------------------------------------------------------------------------------------------------------------------------------------------------------------------------------------------------------------------------------------------------------------------------------------------------------------------------------------------------------------------------------------------------------------------------------------------------------------------------------------------------------------------|
| 3. Plant native tree species at densities greater than 280 trees per acre. Plant native shrub species in forested communities at densities greater than 1,800 plants per acre. | <p>Forest wetlands will have at least 80% cover<sup>d</sup> of native species by monitoring year 15.</p> <p>Forest wetlands will have no more than 10% cover of non-native invasive<sup>e</sup> species during any monitoring year.</p> <p>At the end of year 1, survival of planted stock will be 100%. Average survival of planted stock will be at least 80% in the first 3 monitoring years.</p> <p>In monitoring years 3, 8, and 15, forested areas will have multiple strata, tree density will be at least 280 trees per acre in forested wetland areas and shrub density will be at least 1,800 individual plants per acre in areas of the forested wetland that are planted with shrubs (i.e., over 25% to 50% of the area). Plant diversity in each stratum will not decrease by more than 10% from the number plant species installed at baseline.</p> | <p>Verify using record surveys and vegetation monitoring.</p> <p>Vegetation sampling (plots, transects, or plotless techniques) to determine plant mortality, density, cover, and presence of invasive species.</p> <p>Vegetation analysis will employ statistically valid sampling and analysis procedures.</p> | <p>Replant as necessary to meet required density.</p> <p>If standards are not met:</p> <p>Select species that are better adapted to existing hydrologic conditions.</p> <p>Install additional plant material.</p> <p>Install protective collars to reduce herbivore damage.</p> <p>Control/reduce non-native invasive species.</p> <p>Implement integrated weed management plan, which may include test plots to evaluate potential control methods, mechanical removal, manual controls (i.e., chopping, digging), mowing, mulching, biological control, and/or herbicides.</p> |

Table 7.7-1. Auburn Wetland Mitigation Site monitoring methods and schedule (continued).

| Design Criteria                                                                                                                                                                                                                                                                            | Performance Standard                                                                                                                                                                                                                                                                                                                                                                                                                                                                                                                                                                                                                                                                                                                                                                                                                                                                                  | Evaluation Approach | Contingency Measures |
|--------------------------------------------------------------------------------------------------------------------------------------------------------------------------------------------------------------------------------------------------------------------------------------------|-------------------------------------------------------------------------------------------------------------------------------------------------------------------------------------------------------------------------------------------------------------------------------------------------------------------------------------------------------------------------------------------------------------------------------------------------------------------------------------------------------------------------------------------------------------------------------------------------------------------------------------------------------------------------------------------------------------------------------------------------------------------------------------------------------------------------------------------------------------------------------------------------------|---------------------|----------------------|
| <p>4. Plant an association of native shrub wetland species that is similar in composition to naturally occurring shrub wetlands, including species such as Pacific willow, Hooker's willow, Sitka willow, red-osier dogwood, and twinberry.</p>                                            | <p>Shrub wetlands will cover at least 6.0 acres of the mitigation site.</p> <p>Species composition in the shrub wetland will include at least a 5% cover of each native species planted in monitoring years 3, 8, and 15.</p> <p>At the end of year 1, survival of planted stock will be 100%. Average survival of planted stock will be at least 80% during the first 3 monitoring years. In monitoring years 3, 8, and 15, shrub density will be at least 2,100 plants per acre in shrub wetland areas.</p> <p>Cover of native species will be at least 80% by monitoring year 15<sup>d</sup>.</p> <p>Shrub areas will have no more than 10% cover of non-native invasive<sup>e</sup> species during any monitoring year.</p> <p>In monitoring years 3, 8, and 15, plant diversity in each stratum will not decrease by more than 10% from the number and type of plants installed at baseline.</p> | <p>See above.</p>   | <p>See above.</p>    |
| <p>5. Plant an association of native emergent wetland species similar in composition to naturally occurring emergent wetlands. Use native species that are suited to seasonally and/or permanently flooded conditions, such as water parsley, hardstem bulrush, and common spike rush.</p> | <p>Emergent wetlands and open-water habitat will cover at least 6.8 acres of the mitigation site.</p> <p>Native emergent wetland species will contribute at least 90% of plant cover in areas planted with emergent species by monitoring year 15<sup>d</sup>. During any monitoring year, no more than 10 percent cover by <i>Typha latifolia</i> will be present.</p>                                                                                                                                                                                                                                                                                                                                                                                                                                                                                                                               | <p>See above.</p>   | <p>See above.</p>    |

Table 7.7-1. Auburn Wetland Mitigation Site monitoring methods and schedule (continued).

| Design Criteria                                                                                                                                                                                                                                          | Performance Standard                                                                                                                                                                                                                                                                                                                                                              | Evaluation Approach                                                                                                                 | Contingency Measures                    |
|----------------------------------------------------------------------------------------------------------------------------------------------------------------------------------------------------------------------------------------------------------|-----------------------------------------------------------------------------------------------------------------------------------------------------------------------------------------------------------------------------------------------------------------------------------------------------------------------------------------------------------------------------------|-------------------------------------------------------------------------------------------------------------------------------------|-----------------------------------------|
| 6. Plant native emergent species in approximately 0.05-acre monotypic patches.                                                                                                                                                                           | Species composition in the emergent wetland will include at least a 5% cover of each native species planted.<br><br>Emergent areas will have no more than 10% cover of non-native invasive species during any monitoring year. By the end of year 3, plant diversity in each stratum will not decrease by more than 10% from the number and type of plants installed at baseline. | See above.                                                                                                                          | See above.                              |
| 7. Provide year-round shallow water with patches of emergent vegetation as feeding habitat for dabbling duck species.                                                                                                                                    | Permanently flooded wetlands (at least 0.59 acres) will have shallow-water habitat (<12 inches deep during the June to September period) in 20% of their area.<br><br>Open water, shallow aquatic bed areas will cover at least 0.59 acres.                                                                                                                                       | Hydrologic monitoring and vegetation surveys.                                                                                       | Replant or minor grading as necessary.  |
| 8. Provide ponded water areas for waterfowl resting habitat.                                                                                                                                                                                             | Ponded water at least 26 inches deep will occur in open areas of at least 1 acre from December through May.                                                                                                                                                                                                                                                                       | Hydrologic monitoring.                                                                                                              | Minor grading as necessary.             |
| 9. Plant forested wetland adjacent to shrub, emergent, and open-water habitats.                                                                                                                                                                          | Forested vegetation with trees at densities of 280 stems per acre will occur within 50 ft of the edge of flooded emergent wetland areas for at least 200 linear ft                                                                                                                                                                                                                | Vegetation monitoring, site mapping.                                                                                                | Replant as necessary.                   |
| 10. LWD (stumps and logs of native species) placed throughout the forested wetland to provide year-round cover for small mammals.<br><br>Low hummocks constructed in the shrub wetland areas to provide non-saturated soils for burrowing small mammals. | LWD placed at densities of 50 pieces per acre (approximately 25 ft on-center).<br><br>LWD pieces will be at least 6 ft in length and at least 1 ft in diameter at the narrowest part; 25% of the LWD will be greater than 10 ft long and greater than 2 ft in diameter at the narrowest end. Root wads will be at least 4 ft long and 1 ft in diameter at the stump end.          | As-built surveys for wood placement and topography.<br><br>As-built surveys to verify grades; vegetation surveys. Wildlife surveys. | Supplement with more wood as necessary. |

Table 7.7-1. Auburn Wetland Mitigation Site monitoring methods and schedule (continued).

| Design Criteria                                                                           | Performance Standard                                                                                                                                                                                                                                                                                                                                                                                                                                                                                                                                                                                                                                                                                                                                               | Evaluation Approach                                                                                                                            | Contingency Measures                                                                                                                                                                                                                                                                                                                                                                                                                                                                                  |
|-------------------------------------------------------------------------------------------|--------------------------------------------------------------------------------------------------------------------------------------------------------------------------------------------------------------------------------------------------------------------------------------------------------------------------------------------------------------------------------------------------------------------------------------------------------------------------------------------------------------------------------------------------------------------------------------------------------------------------------------------------------------------------------------------------------------------------------------------------------------------|------------------------------------------------------------------------------------------------------------------------------------------------|-------------------------------------------------------------------------------------------------------------------------------------------------------------------------------------------------------------------------------------------------------------------------------------------------------------------------------------------------------------------------------------------------------------------------------------------------------------------------------------------------------|
| 11. Provide attachment substrate for breeding amphibian species in areas of ponded water. | Shrub hummocks (with a minimum area of 150 ft <sup>2</sup> at elevation 43 ft) at least 4 per acre in the shrub zone.<br>At least 50% of live and dead stems in ponded emergent wetland areas will be species with stem diameters less than 0.25 inch.                                                                                                                                                                                                                                                                                                                                                                                                                                                                                                             | Vegetation surveys.                                                                                                                            | Replant as necessary.                                                                                                                                                                                                                                                                                                                                                                                                                                                                                 |
| <b>Existing Wetland</b>                                                                   |                                                                                                                                                                                                                                                                                                                                                                                                                                                                                                                                                                                                                                                                                                                                                                    |                                                                                                                                                |                                                                                                                                                                                                                                                                                                                                                                                                                                                                                                       |
| 12. Enhance habitat functions of existing wetland.                                        | Plant sections of the existing wetland with native trees and shrubs at densities of at least 2,100 individual plants per acre for shrubs and at least 280 stems per acre for native trees.<br>At the end of Year 1, survival of planted stock will be 100%. Average survival of planted stock in the enhanced wetland will be at least 80% during the first 3 monitoring years.<br>Cover of native species in the enhanced wetland will be at least 80% by monitoring year 15 <sup>d</sup> .<br>Cover of non-native invasive <sup>e</sup> species will be no more than 10% in any monitoring year.<br>In monitoring years 3, 8, and 15, plant diversity in each stratum will not decrease by more than 10% from the number of plant species installed at baseline. | Vegetation sampling (plots, transects, or plotless techniques) to determine plant mortality, density, cover, and presence of invasive species. | If standards are not met:<br>Select species that are better adapted to existing hydrologic conditions.<br>Install additional plant material.<br>Install protective collars to reduce herbivore damage.<br>Control/reduce non-native invasive species.<br>Implement integrated weed management plan, which may include test plots to evaluate potential control methods, use of mechanical removal, manual controls (i.e., chopping, digging), mowing, mulching, biological control, and/or herbicides |
| <b>Buffers</b>                                                                            |                                                                                                                                                                                                                                                                                                                                                                                                                                                                                                                                                                                                                                                                                                                                                                    |                                                                                                                                                |                                                                                                                                                                                                                                                                                                                                                                                                                                                                                                       |
| 13. Establish a 100-ft-wide forested buffer around the perimeter of the mitigation site.  | At the end of Year 1, survival of planted stock will be 100%. Average survival of                                                                                                                                                                                                                                                                                                                                                                                                                                                                                                                                                                                                                                                                                  | See above.                                                                                                                                     | See above.                                                                                                                                                                                                                                                                                                                                                                                                                                                                                            |

Table 7.7-1. Auburn Wetland Mitigation Site monitoring methods and schedule (continued).

| Design Criteria                                                                                                                                             | Performance Standard                                                                                                                                                                                                                                                                                                                                                                                                                                    | Evaluation Approach | Contingency Measures |
|-------------------------------------------------------------------------------------------------------------------------------------------------------------|---------------------------------------------------------------------------------------------------------------------------------------------------------------------------------------------------------------------------------------------------------------------------------------------------------------------------------------------------------------------------------------------------------------------------------------------------------|---------------------|----------------------|
| The buffer will be densely planted with native trees and shrubs to provide site protection and discourage access to the site by people or domestic animals. | planted stock in the buffer will be at least 80% during the first 3 monitoring years.<br>Cover of native species in the buffer will be at least 80% by monitoring year 15 <sup>d</sup> .                                                                                                                                                                                                                                                                |                     |                      |
|                                                                                                                                                             | Cover of non-native invasive <sup>e</sup> species will be no more than 10% during any monitoring year.<br>During years 3, 8, and 15, plant diversity in each stratum will not decrease by more than 10% from the number plant species installed at baseline.                                                                                                                                                                                            |                     |                      |
| <sup>a</sup>                                                                                                                                                | All hydrologic criteria (water depths, soil saturation, etc.) must be met during years of normal rainfall. Normal rainfall will be based on the definition for 'most years' given in the ACOE Manual (Environmental Laboratory 1987) (i.e. annual precipitation in a normal year must be the same as or greater than precipitation in 5 years out of 10) or the average precipitation for a time period plus or minus 1 standard deviation of the mean. |                     |                      |
| <sup>b</sup>                                                                                                                                                | Growing season as defined by the NRCS: portion of year when soil temperatures at 19.7 inches below soil surface are higher than biological zero (i.e., 5°C. From King County Soil Survey, this period is assumed to begin March 1 and is between 190 to 220 days in portions of the County near Puget Sound.                                                                                                                                            |                     |                      |
| <sup>c</sup>                                                                                                                                                | Native species are those defined as native to the Pacific Northwest per Hitchcock and Cronquist, 1973.                                                                                                                                                                                                                                                                                                                                                  |                     |                      |
| <sup>d</sup>                                                                                                                                                | See Table 4.3-1 for interim percent cover targets for the mitigation site (i.e., between years 1 and 15).                                                                                                                                                                                                                                                                                                                                               |                     |                      |
| <sup>e</sup>                                                                                                                                                | See Table 4.3-2 for list of non-native invasive species to be monitored and controlled on the mitigation site.                                                                                                                                                                                                                                                                                                                                          |                     |                      |

Reed canarygrass is present in wetland areas on and adjacent to the mitigation site, and this undesirable species could spread into mitigation wetlands via seed dispersal. To control the spread of reed canarygrass and to ensure the success of native plant establishment, contingency measures as well as routine maintenance actions may be required. Potential control measures include periodic mowing, reseeding with native wetland grasses, and/or treatment with an EPA-approved herbicide.

Because of the planting approach taken (hydroseeding, densely planting fast growing species, and very wet emergent areas), the need for long-term control of reed canarygrass on the site is not anticipated. The dense planting of forested vegetation, including a significant conifer component, will provide dense shade over much of the site. Shade from the forest canopy will greatly reduce the likelihood that reed canarygrass can persist on the site over the long term. The emergent wetlands are designed to be too wet for this species, and it is unlikely to out-compete native wetland plants once they are established in the emergent zone. Hydroseeding at the time of construction should also limit the ability of reed canarygrass to become established.

#### **7.7.2.2 Reducing Herbivore Damage**

Vegetation at newly planted mitigation sites can be vulnerable to browse by Canada geese, deer, voles, beaver, and other wildlife species. In order to avoid significant loss of planted species, a number of contingency measures may be necessary. Stem collars may be installed around the base of woody species or netting may be placed over some plantings. A combination of cayenne pepper and pruning wax applied to woody stems has been an effective deterrent to herbivory at the Auburn Race Track mitigation site and may be used. Temporary netting or other temporary enclosure system may be supported 1 to 2 ft above the ground surface in emergent wetland areas to reduce damage by geese. These and other contingency measures may be employed on a case-by-case basis.

#### **7.7.3 Performance Standards**

In addition to overall goals and objectives, specific design criteria and performance standards (see Table 7.1-2) were developed to achieve the established wetland mitigation goals. Performance standards are measurable criteria that can be evaluated to demonstrate when a mitigation element has been successfully implemented. Performance standards were developed for each design objective (see Table 7.1-2). During the monitoring period, these performance standards will be evaluated to determine the need for contingency or adaptive management actions. At the end of the monitoring period, performance standards will be used to determine if the project has successfully met design objectives and goals.



References

AR 049397

## 8. REFERENCES

- ACOE (U.S. Army Corps of Engineers). 1982. Clarification of "normal circumstances" in the wetland definition. Regulatory Guidance Letter No. 82-2.
- ACOE (U.S. Army Corps of Engineers). 1986. Clarification of "normal circumstances" in wetland definition. Regulatory Guidance Letter No. 86-9 (33 CFR 323.2(c)).
- ACOE (U.S. Army Corps of Engineers). 1990. Clarification and Interpretation of the 1987 Manual. Regulatory Guidance Letter No. 90-7.
- ACOE (U.S. Army Corps of Engineers). 1992. Clarification and interpretation of the 1987 manual. 3-92 Memorandum.
- ACOE (U.S. Army Corps of Engineers). 1994. Washington regional guidance on the 1987 wetland delineation manual. 5-94 Public Notice.
- ACOE (U.S. Army Corps of Engineers). 1995. Mill Creek SAMP wetlands management plan (Draft #6 Submittal). Seattle, Washington.
- ACOE (U.S. Army Corps of Engineers). 1997. Mill Creek Basin, King County, Washington. Aquatic resources restoration plan, Draft 1. Seattle, Washington.
- ACOE (U.S. Army Corps of Engineers). 2001. Guidance for the establishment and maintenance of compensatory mitigation projects under the Corps Regulatory Program pursuant to Section 404(a) of the Clean Water Act and Section 10 of the River and Harbors Act of 1899. Regulatory Guidance Letter 01-01.
- Adamus, P.R., E.J. Clairain, R.D. Smith, and R.E. Young. 1987. Wetland evaluation technique (WET). Volume II, Methodology. Department of the Army, U.S. Army Corps of Engineers. Washington, D.C.
- Allan, J.D. 1995. Stream ecology; Structure and function of running waters. School of Natural Resources and Environment, University of Michigan. Kluwer Academic Publishers, Boston, Massachusetts. Pp. 132-134.
- Aquatic Resource Consultants. 1996. Electrofishing results from Miller Creek. Unpublished memorandum by Aquatic Resource Consultants to Gary Minton, Resource Planning Associates. Seattle, Washington.
- Auburn, City of. 1995. Comprehensive zoning map. Auburn, Washington.
- Bellevue, City of. 1984. Bellevue urban runoff program. Bellevue, Washington.
- Bellevue, City of. 1996. City of Bellevue stormwater monitoring report for Sturtevant Creek. Bellevue, Washington.

- Belt, G.H., J. O'Laughlin, T. Merrill. 1992. Design of forest riparian buffer strips for the protection of water quality: Analysis of scientific literature. Idaho Forest, Wildlife and Range Policy Analysis Group, Report No. 8. Moscow, Idaho.
- Beschta, R.L., R.E. Bilby, G.W. Brown, L.B. Holtby, and T.D. Hofstra. 1987. Stream temperature and aquatic habitat: Fisheries and forestry interactions. Pages 191-232 in: E.O. Salo and T.W. Cundy (eds.). Streamside management: Forestry and fishery interactions, proceedings of a symposium. University of Washington Institute of Forest Resources, Contribution 57. Seattle, Washington.
- Bisson, P.A., R.E. Bilby, M.D. Bryant, C.A. Dolloff, G.B. Grette, R.A. House, M.L. Murphy, K.V. Koski, and J.R. Sedell. 1987. Large woody debris in forested streams in the Pacific Northwest. Pages 143-190 in: E.O. Salo and T.W. Cundy (eds.). Streamside management: Forestry and fishery interactions, proceedings of a symposium. University of Washington Institute of Forest Resources, Contribution 57. Seattle, Washington.
- Bisson, P.A. and R.E. Bilby. 1998. Organic matter and trophic dynamics. Pages 373-398 in: R.J. Naiman and R.E. Bilby (eds.). River Ecology Management: Lessons from the Pacific Coastal Ecoregion. Springer-Verlag New York, Inc. New York, New York.
- Booth, D.B. 1991. Urbanization and the natural drainage system—impacts, solutions, and prognosis. *The Northwest Environmental Journal*, 7:93-118.
- Booth, D.B. and L. Reinelt. 1993. Consequences of urbanization on aquatic systems—measured effects, degradation thresholds, and corrective strategies. In Proceedings Watershed '93. U.S. Bureau of Reclamation, March 21-23, Alexandria, Virginia.
- Booth, D.B. and R.R. Horner. 1995. Fundamentals of urban surface water management. Section IV, course manual for class offered in cooperation with University of Washington Engineering Professional Programs. Seattle, Washington. September 1995.
- Booth, D.B. and C.R. Jackson. 1997. Urbanization of aquatic systems – degradation thresholds, stormwater detention, and limits of mitigation. *Journal of the American Water Resources Association*, Vol. 22, No. 5.
- Brinson, M.M. 1993. A hydrogeomorphic classification for wetlands. Technical report WRP-DE-4. U.S. Army Corps of Engineers Waterways Experiment Station. Vicksburg, Mississippi.
- Brown, E.R. 1961. The black-tailed deer of western Washington. Biological bulletin. Washington State Game Department. Olympia, Washington.
- Butler & Associates and Sheldon & Associates. 1992. Seattle-Tacoma International Airport wetland management plan. Report for the Port of Seattle. Seattle, Washington.
- Canfield, R. 1941. Application of the line intercept method in sampling range vegetation. *Journal of Forestry*, 39:388-394.

- Castelle, A.J., S. Luchessa, C. Conolly, M. Emers, E.D. Metz, S. Meyer, and M. Witter. 1992. Wetland mitigation banking. Washington State Department of Ecology, Publication 92-12. Olympia, Washington.
- Cederholm, C.J., L.G. Dominguez, and T.W. Bumstead. 1997. Rehabilitating stream channels and fish habitat using large woody debris. Pages 8-1 through 8-28 in; P.A. Slaney and D. Zaldokas (eds.). Fish habitat rehabilitation procedures. Watershed Restoration Technical Circular No. 9. Watershed Restoration Program, Ministry of Environment, Lands and Parks, Vancouver, B.C., Canada.
- CH2M Hill and Associated Firms. 1995. Draft environmental impact statement for the Des Moines Creek Technology Campus. Prepared for the City of Des Moines and Port of Seattle. Seattle, Washington.
- Chui, T.W.; B.W. Mar; and R.R. Horner. 1982. Pollutant loading model for highway runoff. Proceedings of the American Society of Civil Engineers. *Journal of the Environmental Engineering Division*, 108(EE6):1193-1211. Bellevue, Washington.
- Cosmopolitan Engineering Group. 1999 (in preparation). Seattle-Tacoma International Airport dissolved oxygen de-icing study. Prepared by Cosmopolitan Engineering Group for the Port of Seattle. Tacoma, Washington.
- Conover, M.R., W.C. Pitt, K.K. Kessler, T.J. Dubow, and W.A. Sanborn. 1996. Review of human injuries, illness, and economic losses caused by wildlife in the United States. *Wildlife Society Bulletin*, 23:407-414.
- Cooke Scientific Services Inc. 1996. Wetland and buffer functions and semi-quantitative assessment methodology. Cooke Scientific Services. Seattle, Washington.
- Corn, P.S. and R.B. Bury. 1990. Sampling methods for terrestrial amphibians and reptiles. Cary, A.B. and L.F. Ruggiero (eds.) *Wildlife-habitat relationships: sampling procedures for Pacific Northwest vertebrates*. USDA Forest Service. General Technical Report PNW-GTR-256. Portland, Oregon.
- Cowardin, L.M., V. Carter, F.C. Golet, and E.T. LaRoe. 1979. Classification of wetlands and deep water habitats of the United States. U.S. Fish and Wildlife Service, U.S. Department of Interior. Washington, D.C.
- Daubenmire, R. 1959. A canopy-coverage method of vegetational analysis. *Northwest Science*, 33:43-64.
- David Evans and Associates, Inc. 1995. Wetland determination on the Riverbend Master Plan Community. Report by David Evans and Associates to Gentra Capital Corporation. Seattle, Washington.

- Des Moines Creek Basin Committee. 1997. Des Moines Creek Basin Plan. Des Moines Creek Basin Committee (City of SeaTac, City of Des Moines, Port of Seattle, and King County Surface Water Management). Seattle, Washington.
- Dorman, M.E., J. Hartigan, F. Johnson, and B. Maestri. 1988. Retention, detention, and overland flow for pollutant removal from urban stormwater runoff. Federal Highway Administration. FWHA/RD-87/056. McLean, Virginia.
- Duwamish Coalition. 1996. Lower Duwamish watershed habitat restoration plan (final draft). Seattle, Washington.
- Earth Tech, Inc. 2000. Low streamflow analysis for Seattle-Tacoma Airport Master Plan Update. Prepared by Earth Tech for the Port of Seattle. Bellevue, Washington.
- Ecology (Washington State Department of Ecology). 1990. Model wetlands protection ordinance. Olympia, Washington.
- Ecology (Washington State Department of Ecology). 1993. Washington state wetlands rating system. Publication 93-74. Olympia, Washington.
- Ecology (Washington State Department of Ecology). 1994a. Guidelines for developing freshwater wetlands mitigation plans and proposals. Olympia, Washington.
- Ecology (Washington State Department of Ecology). 1994b. National pollutant discharge elimination system permit number WA-002465-1, issued February 20, 1998 by Washington Department of Ecology. Olympia, Washington.
- Ecology (Washington State Department of Ecology). 1995. Use of the 1987 U.S. Army Corps of Engineers wetlands delineation manual. 3-95 Public Notice.
- Ecology (Washington State Department of Ecology). 1996. An approach to developing methods to assess the performance of Washington's wetlands. Publication 96-110. Olympia, Washington.
- Ecology (Washington State Department of Ecology). 1997. Washington state wetlands identification and delineation manual. Publication 96-94. Olympia, Washington.
- Ecology (Washington State Department of Ecology). 1999. Methods for assessing wetland functions. Publication 99-116. Olympia, Washington.
- Ecology (Washington State Department of Ecology). 2001a. Order #96-4-02325: Water quality certification/coastal zone consistency determination for Port of Seattle—master plan improvements project. September 21, 2001. Unpublished letter from Ecology to Port of Seattle. Seattle, Washington.
- Ecology (Washington State Department of Ecology). 2001b. Stormwater management manual for Western Washington. Washington State Department of Ecology Water Quality Program. Publication Nos 99-11 through 99-15.

- ECOTOXNet. 1996. Glyphosphate. Extension toxicology network – pesticide information profiles. <http://ace.orst.edu/info/exonet/pips/glyphosa.htm>.
- Ehrlich, P.R., D.S. Dobkin, and D. Wheye. 1988. *The birder's handbook: A field guide to the natural history of North American birds*. Simon & Shuster. New York, New York.
- Elzinga, C.L., D.W. Salzer, and J.W. Willoughby. 1998. Measuring and monitoring plant populations. Bureau of Land Management. Denver, Colorado.
- Emmett, B.A., J.A. Hudson, P.A. Coward, and B. Reynolds. 1994. The impact of a riparian wetland on streamwater quality in a recently afforested upland catchment. *Journal of Hydrology*, 162:337-353.
- Environmental Laboratory. 1987. U.S. Army Corps of Engineers wetland delineation manual. Technical Report Y-87-1, U.S. Army Corps of Engineers Waterways Experiment Station. Vicksburg, Mississippi.
- EPA (U.S. Environmental Protection Agency) and ACOE (Army Corps of Engineers). 1993. Memorandum to the field, Establishment and use of wetland mitigation banks in the Clean Water Act Section 404 regulatory program. August 23, 1993.
- EPA (U.S. Environmental Protection Agency). 1983. Results of the nationwide urban runoff program. NTIS PB84-185552. Washington, D.C.
- EPA (U.S. Environmental Protection Agency). 1984. Guidelines for deriving numerical aquatic site-specific water quality criteria by modifying national criteria. U.S. EPA-600/3-84-099. Duluth, Minnesota.
- EPA (U.S. Environmental Protection Agency). 1986. Quality criteria for water. Office of Water Regulation and Standards. U.S. EPA 440/5-86-001. Washington, D.C.
- EPA (U.S. Environmental Protection Agency). 1991. Technical support document for water quality based toxics control. U.S. EPA/505/2-90-001. Cincinnati, Ohio.
- EPA (U.S. Environmental Protection Agency). 1993. Hydrological simulation program—FORTRAN, Users manual for release 10. Environmental Research Laboratory, Office of Research and Development, U.S. EPA. Athens, Georgia.
- EPA (U.S. Environmental Protection Agency). 1994. Interim guidance on determination and use of water-effect ratios for metal. U.S. EPA/823/b94/001. Washington, D.C.
- FAA (Federal Aviation Administration). 1994. Final environmental impact statement for the South Aviation Support Area. Port of Seattle. SeaTac, Washington.
- FAA (Federal Aviation Administration). 1995. Draft final environmental impact statement for proposed master plan update development activities at Seattle-Tacoma International Airport, Appendix H-A: Jurisdictional wetland delineation report. Prepared for the Port of Seattle. Seattle, Washington.

- FAA (Federal Aviation Administration). 1996. Final environmental impact statement for proposed master plan update development actions at Seattle-Tacoma International Airport. Prepared for the Port of Seattle. SeaTac, Washington.
- FAA (Federal Aviation Administration). 1997a. Final supplemental environmental impact statement for the proposed master plan update at Seattle Tacoma International Airport. Port of Seattle. Seattle, Washington.
- FAA (Federal Aviation Administration). 1997b. Hazardous wildlife attractants on or near airports. Advisory Circular, 150/5200-33.
- FAA (Federal Aviation Administration). 1997c. Record of Decision for the master plan update development actions, Sea-Tac International Airport. July 3, 1997.
- Federal Register. 1986. Regulatory programs of the U.S. Army Corps of Engineers. Final Rule. Volume 51, No. 219; 33 CFR Parts 320 through 330. U.S. Government Printing Office. Washington, D.C.
- Federal Register. 1995. Federal guidance for the establishment, use and operation of mitigation banks (60 CFR 58605). 60:58605-58614. U.S. Government Printing Office. Washington, D.C.
- FEMA (Federal Emergency Management Agency). 1989. Flood Insurance Rate Map, King County, Washington and Incorporated Areas. Panel 310 of 650, Map Number 53033c0310D. Effective date September 29, 1989.
- Fiebig, D.M., M.A. Lock, and C. Neal. 1990. Soil water in the riparian zone as a source of carbon for a headwater stream. *Journal of Hydrology*, 116:217-237.
- FICWD (Federal Interagency Committee for Wetland Delineation). 1989. Federal manual for identifying and delineating jurisdictional wetlands. ACOE, U.S. EPA, USFWS, USDA Soil Conservation Service. Washington, D.C.
- Fisheries and Oceans. 1980. Stream enhancement guide. Prepared for the Province of British Columbia, Ministry of Environment by Kerr Wood Leidel Associates Ltd. and D.B. Lister and Associates Ltd. Vancouver, BC, Canada.
- Ford, T.E. 1993. Aquatic microbiology, an ecological approach. Department of Environmental Health, Harvard School of Public Health, Boston, Massachusetts.
- Fore, L.S.; J.R. Karr; and R. Wisseman. 1996. Assessing invertebrate responses to human activities: evaluating alternative approaches. *Journal of the North American Benthological Society*, 15(2):212-231.

- Harmon, M.E., J.F. Franklin, F.J. Swanson, P. Sollins, S.U. Gregory, J.D. Lattin, N.H. Anderson, S.P. Cline, N.G. Aumen, J.R. Sedell, G.W. Lienkaemper, K. Cromack, Jr., and K.W. Cummins. 1986. Ecology of coarse woody debris in temperate ecosystems. Pages 133-302 in: A. MacFadyen and E.D. Ford (eds.). *Advances in ecological research*. Volume 15. Academic Press, London, England.
- Hart Crowser. 2000a. Effects of infiltration and baseflow – Proposed Third Runway Embankment. Memorandum by Hart Crowser to Jim Tomson, HNTB.
- Hart Crowser. 2000b. Sea-Tac Third Runway Project, Borrow Areas 1, 3, and 4 – Projected impacts to wetlands. Unpublished memo by Hart Crowser to Ralph Wessels, Port of Seattle. Seattle, Washington. 17 pp.
- Hart Crowser. 2000c. Sea-Tac third runway project, Borrow Area 3 – Preservation of wetlands. Unpublished memo by Hart Crowser to Jim Thompson, HNTB. Seattle, Washington. 9 pp plus attachments.
- Hart Crowser. 2001a. Avoidance of Wetland Impacts – Temporary Stormwater Pond A, SeaTac Third Runway. Prepared by HNTB and Port of Seattle.
- Hart Crowser. 2001b. Borrow Area 3 Wetland Protection Swale Design Drawings 1-4.
- Hauer, R. R. and G. Lamberti (eds.). 1996. *Methods in stream ecology*. Academic Press, San Diego, California.
- Herrera and RW Beck. 2000. Description of existing conditions and alternatives for improvement, Gilliam Creek Basin. Prepared for City of Tukwila, Public Works Department. Seattle, Washington.
- Hewlett, J.D. and J.C. Fortson. 1992. Stream temperature under an inadequate buffer strip in the southeast Piedmont. *Wat. Resour. Bull.*, 18:983-988.
- Hillman, T.W., J.R. Stevenson, and D.J. Snyder. 1999. Assessment of spawning and habitat in three Puget Sound streams, Washington. Prepared for Airport Communities Coalition. Des Moines, Washington. April 1999.
- Hitchcock, C.L. and A. Cronquist. 1973. *Flora of the Pacific Northwest*. University of Washington Press. Seattle, Washington.
- Horner, R.R., D.B. Booth, A. Azous, and C.W. May. 1996. Watershed determinants of ecosystem functioning. Proceedings of an Engineering Foundation Conference. American Society of Civil Engineers. Snowbird, Utah.
- Hruby, T., W.E. Cesanek, and K.E. Miller. 1995. Estimating relative wetland values for regional planning. *Wetlands*, 15(2):93-106.



- Hurt, G.W. et al. 1998. Field indicators of hydric soils in the United States. A guide for identifying and delineating hydric soils (ver. 4). U.S. Department of Agriculture, Natural Resource Conservation Service. Fort Worth, Texas.
- HWA GeoSciences, Inc. 1998. Geotechnical and dewatering evaluation Miller Creek relocation Seattle-Tacoma International Airport, Washington. Prepared for Parametrix, Inc. Lynwood, Washington.
- Johnson A.W. and D.M. Ryba. 1992. A literature review of recommended buffer widths to maintain various functions of stream riparian areas. Prepared for King County Surface Water Management Division, Aquatic Resource Consultants, Seattle, Washington. 28 pp.
- Karr, J.R. and E.W. Chu. 1999. Restoring life in running waters: Better biological monitoring. Island Press, Washington, D.C.
- KCSWM (King County Surface Water Management Division). 1987. Miller Creek basin reconnaissance report no. 12. King County Department of Natural Resources. Seattle, Washington.
- KCSWM (King County Surface Water Management Division). 1994. Mean daily discharge from Lake Reba outflow at Lake Reba detention pond. Water years 1990-1994. Seattle, Washington.
- Kent, M. and P. Coker. 1994. Vegetation Description and Analysis – A Practical Approach. John Wiley and Sons, Chichester, England.
- Kerans, B.L. and J.R. Karr. 1994. A benthic index of biotic integrity (BIBI) for rivers of the Tennessee Valley. *Ecological Applications*, 4(4):768-785).
- King County. 1988. Seattle-Tacoma Area Update Plan. King County Planning and Community Development Division. King County, Washington.
- King County. 1990. King County sensitive areas map folio. King County Department of Parks, Planning and Resources, Planning and Community Development Division. Seattle, Washington.
- King County CIP Design Team (King County Capital Improvement Project Design Team). 1999. Des Moines Creek regional capital improvement projects preliminary design report. CIP Design Team, King County Department of Natural Resources, Water and Land Resources Division. Seattle, Washington.
- King County DNR (King County Department of Natural Resources). 1998. King County Surface Water Design Manual. King County Department of Natural Resources, Water and Land Resources Division. Seattle, Washington.
- Kleindl, W.J. 1995. A benthic index of biotic integrity for Puget Sound lowland streams, Washington, USA. M.S. Thesis, University of Washington. Seattle, Washington.

- Knutson, K.L. and V.L. Naef. 1997. Management recommendations for Washington's priority habitats – Riparian. Washington Department of Fish and Wildlife. Olympia, Washington.
- Kunze, L.M. 1994. Preliminary classification of native, low elevation, freshwater wetland vegetation in western Washington. Washington Natural Heritage Program, Department of Natural Resources. Olympia, Washington.
- Locke, G. 1997. Letter from Gary Locke, Governor of Washington, to Rodney Slater, Secretary of the U.S. Department of Transportation. Re: State certification of compliance with applicable air and WQSs. State of Washington, Office of the Governor. Olympia, Washington.
- Lyon, L.A. and D.F. Caccamise. 1981. Habitat selection by roosting black birds and starlings: management implications. *Journal of Wildlife Management*, 45:435-443.
- Martin A.C., H.S. Zim, and A.L. Nelson. 1951. American wildlife and plants: A guide to wildlife food habits. Dover Publications. New York, New York.
- Montgomery Water Group. 1995. Hydrologic modeling study for Seattle-Tacoma Airport master plan update EIS. Montgomery Water Group. Kirkland, Washington.
- Mueller-Dombois, D. and H. Ellenberg. 1974. Aims and methods of vegetation ecology. John Wiley & Sons. New York, New York. 547 pp.
- Munsell Color. 1988. Munsell soil color charts. Kollmorgen Corporation. Baltimore, Maryland.
- Naiman, R.J. and R.E. Bilby (eds.). 1998. River ecology and management. Lessons from the Pacific Coastal Ecoregion. Springer-Verlag, New York, Inc. New York, New York.
- NRCS (Natural Resources Conservation Service). 1985. National food security manual. U.S. Department of Agriculture. Third edition. Amend 2, December 1995. Washington, D.C.
- NRCS (Natural Resources Conservation Service). 2000. Hydric soils list, King County area, Washington: Detailed soil map legend. Found at [http://www.wa.nrcs.usda.gov/FOTG/SECTION2/hydric\\_lists/wa633hyd.doc](http://www.wa.nrcs.usda.gov/FOTG/SECTION2/hydric_lists/wa633hyd.doc). Updated November 13, 2000.
- Nussbaum, R.A., E.D. Brodie, Jr., and R.M. Storm. 1983. Amphibians and reptiles of the Pacific Northwest. University of Idaho Press. Moscow, Idaho.
- Olson, D.H., W.P. Leonard, and R.B. Bury (eds.) 1997. Sampling amphibians in lentic habitats: Methods and approaches for the Pacific Northwest. Society for Northwestern Vertebrate Biology. Olympia, Washington.
- Parametrix. 1992. South Aviation Support Area wetlands discipline report. Prepared by Parametrix for the Port of Seattle. Kirkland, Washington.

- Parametrix. 1995. Proposed wetland mitigation site, Phase I site assessment report. Prepared by Parametrix for the Port of Seattle. Kirkland, Washington.
- Parametrix. 1996. Joint aquatic resource permit application (JARPA) for proposed master plan update improvements at Seattle-Tacoma International Airport. Prepared by Parametrix, Inc. for U.S. Army Corps of Engineers, Washington State Department of Ecology, and Washington Department of Fish and Wildlife. Seattle, Washington.
- Parametrix. 2000a. Comprehensive stormwater management plan for Seattle-Tacoma International Airport master plan update improvements. Prepared by Parametrix for the Port of Seattle. Kirkland, Washington.
- Parametrix. 2000b. Wetland delineation report for Seattle-Tacoma International Airport master plan update improvements. Prepared by Parametrix for the Port of Seattle. Kirkland, Washington.
- Parametrix. 2000c. Biological assessment for Seattle-Tacoma International Airport master plan update improvements. Prepared by Parametrix for the Port of Seattle. Kirkland, Washington.
- Parametrix, Inc. 2001a. Replacement pages for comprehensive stormwater management plan for Seattle-Tacoma International Airport master plan improvements. Prepared for the Port of Seattle. Kirkland, Washington.
- Parametrix. 2001b. Wetland functional assessment and impact analysis for Seattle-Tacoma International Airport master plan update improvements. Prepared by Parametrix for the Port of Seattle. Kirkland, Washington.
- Payne, N.F. and F.C. Bryant. 1992. Techniques for habitat management of uplands. Biological Resource Management Series. McGraw-Hill Publications, New York, New York.
- Pennak, R.W. 1989. Fresh-water invertebrates of the United States, 3rd ed. John Wiley & Sons, Inc., New York, New York.
- Pitt, R. and P. Bissonnette. 1984. Bellevue urban runoff program, summary report. City of Bellevue, Storm and Surface Water Utility. Bellevue, Washington.
- Platts, W.S., W.F. Megahan, and G.W. Minshall. 1983. Methods for evaluating stream, riparian, and biotic conditions. USDA Forest Service, Intermountain Research Station. GTR-INT-138. Ogden, Utah.
- Port of Seattle. 1997. Final supplemental environmental impact statement for proposed master plan update development actions at Seattle-Tacoma International Airport. Prepared for the Port of Seattle. SeaTac, Washington.
- Port of Seattle. 1997a. Annual stormwater monitoring report for the period July 1, 1996 through May 1, 1997. Port of Seattle. Seattle, Washington.

- Port of Seattle. 1997b. Seattle-Tacoma International Airport stormwater pollution prevention plan (SWPPP). Port of Seattle. Seattle, Washington.
- Port of Seattle. 1997c. Stormwater receiving environment monitoring report for NPDES Permit No. WA-002465-1. Port of Seattle. Seattle, Washington.
- Port of Seattle. 1998a. Annual stormwater monitoring report for Seattle-Tacoma International Airport, final draft. Permit # WA-002465-1. Port of Seattle. Seattle, Washington.
- Port of Seattle. 1998b. Port of Seattle Position Paper: Off-airport mitigation of wetland wildlife habitat function. Port of Seattle. Seattle, Washington.
- PSEP (Puget Sound Estuary Program). 1991. Evaluation of the atmospheric deposition of toxic contaminants to Puget Sound. U.S. EPA 910/9-91-027.
- Puget Sound Regional Council. 1994. Satellite remote sensing projects land cover and change detection. Seattle, Washington.
- Ralph, C.J. and J.M. Scott (eds.). 1981. Estimating numbers of terrestrial birds. Proceedings of an International Symposium held at Asilomar, California, October 26-31, 1980 [Studies in Avian Biology, No.6]. Cooper Ornithological Society. Lawrence, Kansas.
- Ramsey, F.L. and J.M. Scott. 1979. Estimating population densities from variable circular plot surveys. Pages 155-182 in: R.M. Cormack, G.P. Patil, and D.S. Robson (eds.). Sampling biological populations. Statistical Ecology Series, Vol 5. International Congress of Ecology. International Cooperative Publishing House, Fairland, Maryland.
- Reed, P.B. 1988. National list of plant species that occur in wetlands: Northwest region (Region 9). U.S. Fish and Wildlife Service. *Biological Report*, 88(26.9). Washington, D.C.
- Reimold, R.J. 1994. Wetlands functions and values. In: D. Kent (ed). Applied wetlands science and technology. Lewis Publishers, Boca Raton, Florida. 436 pp.
- Reppert, R.T., W. Sitleo, E. Stakhiv, L. Messman, and C.D. Meyers. 1979. Wetlands values: Concepts and methods for wetlands evaluation. Institute for Water Resources, U.S. Army Corps of Engineers. Res. Rpt. 79-R1. Fort Bevoir, Virginia.
- Reynolds, R.T., J.M. Scott, and R.A. Nussbaum. 1980. A variable circular-plot method for estimating bird numbers. *Condor*, 82:309-313.
- Richey, J.S. 1982. Effects of urbanization on a lowland stream in western Washington. Ph.D. Dissertation, University of Washington. Seattle, Washington.
- Richter, K.O. and A.L. Azous. 1995. Amphibian occurrence and wetland characteristics in the Puget Sound basin. *Wetlands*, 15(3):305-312.

- SeaTac, City of. 1993. Wetlands and streams classifications in the City of SeaTac. Bmap folio. SeaTac, Washington.
- Seubert, J.L. 1977. Bird strike hazard to turbine powered aircraft. Pages 53-68 in: Proceedings of the third world conference on bird hazards to aircraft. Bird Strike Comm. Europe. Paris, France.
- Shapiro and Associates, Inc. 2000. Auburn Racetrack year four monitoring report. Prepared for Northwest Racing Associates. Seattle, Washington.
- Snyder, D.E., G.P. Philip, and R.F. Russell. 1973. Soil survey of King County area, Washington. United States Department of Agriculture, Soil Conservation Service. In cooperation with the Washington agricultural experiment station.
- Soloman, V.E.F. 1973. Birds and aircraft. *Biological Conservation*, 5:277-278.
- Solomon, C. and N. Sexton. 1994. Methods for evaluating wetland functions. Water Resource Program Technical Note WG-EV-2.2. U.S. Army Corps of Engineers, Waterways Experiment Station. Vicksburg, Mississippi.
- Speaker, R.W., K.J. Luchessa, J.F. Franklin, and S.V. Gregory. 1988. The use of plastic strips to measure leaf retention by riparian vegetation in a coastal Oregon stream. *The American Midland Naturalist*, 120:22-31. Corvallis, Oregon.
- Steward, C.R. 1983. Salmonid populations in an urban stream environment. M.S. thesis, University of Washington. Seattle, Washington.
- Taylor, B.L. 1993. The influence of wetland and watershed morphological characteristics on wetland hydrology and relationships to wetland vegetation communities. M.S. thesis, University of Washington. Seattle, Washington.
- Tukwila, City of. 1997. Riverton Creek Stormwater Quality Management Plan. Water quality, stream habitat, and flood control. City of Tukwila, Washington. November 1997.
- USDA (U.S. Department of Agriculture), Soil Conservation Service. 1973. Soil survey of King County area, Washington. United States Government Printing Office. Washington, D.C.
- USDA (U.S. Department of Agriculture), Soil Conservation Service. 1991. Hydric soils of the United States. U.S. Department of Agriculture, Soil Conservation Service. Miscellaneous Publication No. 1491.
- USDA (U.S. Department of Agriculture). 2000. Wildlife hazard management plan Seattle-Tacoma International Airport. Seattle, Washington.
- USFWS (U.S. Fish and Wildlife Service). 1987. National wetlands inventory, Des Moines, Washington Quadrangle.

- U.S. Forest Service. 1993. Draft supplemental environmental impact statement for late successional and old-growth forest related species within the range of the northern spotted owl. U.S. Forest Service Pacific Northwest Region. Portland, Oregon.
- USGS (U.S. Geological Survey). 1995. 7.5 Minute topographic series, Des Moines, Washington Quadrangle. Revised 1995.
- USGS (U.S. Geological Survey). 1996. Washington surface-water data retrieval. Found on the world wide web at <http://h20.usgs.gov/sur/WA>.
- Williams, R.W., R. Laramie, and J.J. Ames. 1975. A catalog of Washington streams and salmon utilization. Volume I. Washington Department of Fisheries. Puget Sound. Seattle, Washington.



**Port of Seattle**  
**Aviation Division**

# **APPENDICES A-F**

## **DESIGN DRAWINGS**

### **NATURAL RESOURCE MITIGATION PLAN**

### **SEATTLE-TACOMA INTERNATIONAL AIRPORT**

- APPENDIX A - MILLER CREEK RELOCATION AND FLOODPLAIN ENHANCEMENT
- APPENDIX B - MILLER CREEK INSTREAM AND BUFFER ENHANCEMENTS
- APPENDIX C - TYEE VALLEY GOLF COURSE AND DES MOINES CREEK BUFFER PLANTING PLAN
- APPENDIX D - REPLACEMENT DRAINAGE CHANNELS AND RESTORATION OF TEMPORARILY IMPACTED WETLANDS
- APPENDIX E - AUBURN WETLAND MITIGATION
- APPENDIX F - DES MOINES WAY NURSERY WETLAND RESTORATION



**Parametrix, Inc.**

NOVEMBER 2001  
AGENCY REVIEW  
NOT FOR CONSTRUCTION



Port of Seattle  
Aviation Division

# APPENDIX A

# MILLER CREEK RELOCATION SEATTLE-TACOMA INTERNATIONAL AIRPORT

AGENCY REVIEW  
NOT FOR CONSTRUCTION

| SHEET NO.   | SHEET TITLE                                                                          | SHEET NO.   | SHEET TITLE                   | SHEET NO. | SHEET TITLE |
|-------------|--------------------------------------------------------------------------------------|-------------|-------------------------------|-----------|-------------|
| STA-8805-11 | TITLE SHEET                                                                          | STA-8805-11 | IRRIGATION DETAILS AND LEGEND |           |             |
| STA-8805-12 | VICINITY MAP, SYMBOLS, NOTES AND ABBREVIATIONS                                       | STA-8805-12 | IRRIGATION PLAN N             |           |             |
| STA-8805-13 | MILLER CREEK RELOCATION AND FLOODPLAIN ENHANCEMENT                                   | STA-8805-13 | IRRIGATION PLAN S             |           |             |
| STA-8805-14 | CROSS SECTION MILLER CREEK RELOCATION AND S. 154TH/S. 154TH ST. AT STREET STA 106+50 | STA-8805-14 | PLANTING PLAN S               |           |             |
| STA-8805-15 | SITE PLAN                                                                            | STA-8805-15 | PLANTING SCHEDULE AND DETAILS |           |             |
| STA-8805-16 | SITE PLAN - NOTES                                                                    | STA-8805-16 | SHADECLOTH SECTION AND DETAIL |           |             |
| STA-8805-17 | BOULDERATION SWALE AND OUTFALL LOCATION                                              |             |                               |           |             |
| STA-8805-18 | TEMPORARY SWALE WITH STREET (WEST END)                                               |             |                               |           |             |
| STA-8805-19 | TEMPORARY SWALE WITH STREET (EAST END)                                               |             |                               |           |             |
| STA-8805-20 | BOULDERATION SWALE SECTION OF LONA LAKE BUFFER ENHANCEMENT                           |             |                               |           |             |
| STA-8805-21 | CHANNEL PROFILE                                                                      |             |                               |           |             |
| STA-8805-22 | CHANNEL SECTIONS AND DETAILS                                                         |             |                               |           |             |
| STA-8805-23 | FLOODPLAIN SECTIONS                                                                  |             |                               |           |             |
| STA-8805-24 | VACCA FARM FLOOD PLAIN SOIL PROFILE                                                  |             |                               |           |             |
| STA-8805-25 | MISCELLANEOUS SECTIONS AND DETAILS                                                   |             |                               |           |             |
| STA-8805-26 | MICROTOPOGRAPHIC FEATURE DETAIL                                                      |             |                               |           |             |
| STA-8805-27 | HABITAT LOG-LAYOUT PLAN AND DETAILS                                                  |             |                               |           |             |
| STA-8805-28 | TEMPORARY EROSION AND SEDIMENT CONTROL PLAN                                          |             |                               |           |             |
| STA-8805-29 | TEMPORARY EROSION AND SEDIMENT CONTROL SECTIONS AND DETAILS                          |             |                               |           |             |
| STA-8805-30 | TEMPORARY EROSION AND SEDIMENT CONTROL SECTIONS AND DETAILS                          |             |                               |           |             |

MAJOR CONTRACT

RECOMMENDED FOR APPROVAL

APPROVED BY

DATE

DATE

DATE

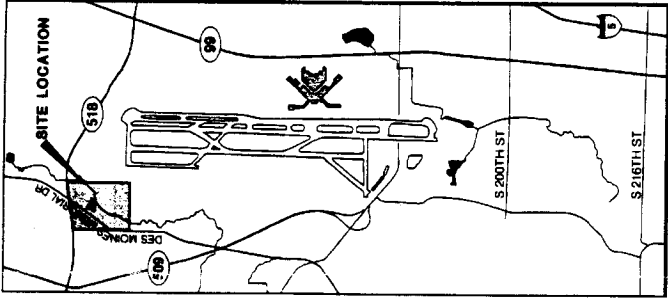
WORK ORDER NO. 10021

PROJECT NO. STA-8805-11

AR 049412



**VICINITY MAP**



**LEGEND**

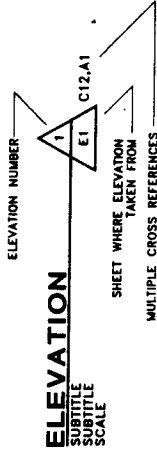
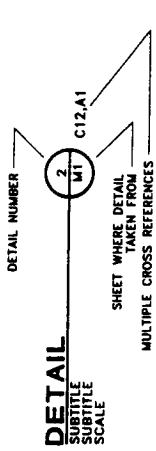
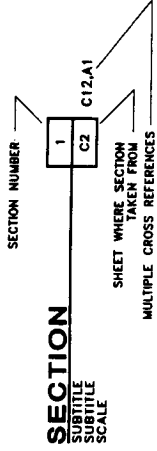
- CULVERT
- SPOT ELEVATION
- KEY NOTE NUMBER REFERENCE
- SURFACE WATER DITCH
- EXISTING CONTOUR
- PROPOSED CONTOUR
- EXISTING GRADE (SECTION)
- SPANNING GRAVEL (SECTION)
- CRUSHED SURFACING BASE COURSE (SECTION)
- QUARRY SPALLS
- CONCRETE
- EMBANKMENT
- NATIVE SUBGRADE
- GRAVEL
- PAVEMENT (PLAN)
- SLOPE INDICATOR
- CONTROL POINT
- SILT FENCE
- SILT CURTAIN
- GEOTEXTILE
- EROSION CONTROL MATTING
- STRAW BALE BARRIER
- EXISTING MONITORING WELL
- CHAIN LINK FENCE
- PRIVATE PROPERTY BOUNDARY
- POINT OF INTERSECTION
- BERM
- CHANNEL CENTERLINE AND STATION
- EXISTING SANITARY SEWER LINE
- PROPOSED SANITARY SEWER LINE
- LIMIT OF CONSTRUCTION (PROJECT)
- SURVEY CONTROL POINT
- LIMIT OF RESTRICTED AREA
- EXISTING STORM DRAIN

**GENERAL LEGEND**

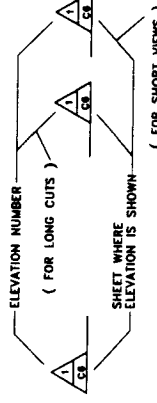
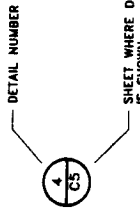
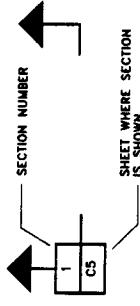
**DRAWING TITLE:**



**PLAN**  
SUBTITLE  
SUBTITLE  
SCALE



**REFERENCE SYMBOL:**



**GENERAL ABBREVIATIONS**

- AND
- ACP
- APPROX.
- AP
- DIA
- DIA
- E
- E
- EL OR ELEV
- ENIS
- FT
- FT
- HT
- HT
- I.E.
- LF
- MAX
- MIN
- MISC
- MISCELLANEOUS
- N
- NO.
- N.T.S.
- O.C.
- PP
- RCP
- S
- SD
- S.F.
- SS
- STA
- TYP
- W
- WD
- VERT/N
- NORTH/NORTHING
- NUMBER
- NOT TO SCALE
- ON CENTER
- POWER POLE
- REINFORCED CONCRETE PIPE
- REINFORCED CONCRETE PIPE
- STORM DRAIN
- SQUARE FOOT/FEET
- SANITARY SEWER
- TYPICAL
- WITH
- WOODY DEBRIS
- VERTICAL

**SURVEY CONTROL POINTS**

- 9704-2 = REBAR WITH YELLOW CAP MARKED PAX CONTROL NEAR THE SOUTHEAST CORNER OF LORA LAKE 11.0' SOUTHERLY OF THE TOP OF THE BANK & 21.0' NORTHWESTERLY FROM A SANITARY SEWER MANHOLE.
- 9704-3 = REBAR WITH YELLOW CAP MARKED PAX CONTROL NEAR THE SOUTHWEST CORNER OF LORA LAKE 6.0' SOUTHERLY OF THE TOP OF BANK & 33.2' WEST SOUTHWEST OF A DOUBLE TRUNK (12" & 12") ALDER TREE.
- 9704-4 = REBAR WITH YELLOW CAP MARKED PAX CONTROL IN THE NORTHWESTERLY MARGIN OF THE DIRT ROAD THAT RUNS BETWEEN THE PUMPKIN PATCHES, 82' +/- EASTERLY OF THE MOST NORTHWESTERLY CORNER OF A WOODEN STORAGE SHED.

NOTE: SEE C2 FOR SURVEY CONTROL POINT COORDINATES AND ELEVATIONS.

**GENERAL NOTES**

1. CALL "DIG-SAFE" (1-800-425-5555) PRIOR TO COMMENCING ANY GRADING OR EXCAVATION WORK ON THE SITE.
2. INSTALLATION OF TEMPORARY EROSION AND SEDIMENT CONTROLS SHALL BE COMPLETED PRIOR TO SITE WORK.

AGENCY REVIEW

NOT FOR CONSTRUCTION

**Parimetrix, Inc.**  
5008 1st Washington Blvd. NE  
Kirkland, WA 98033  
Ph: (425) 822-8800

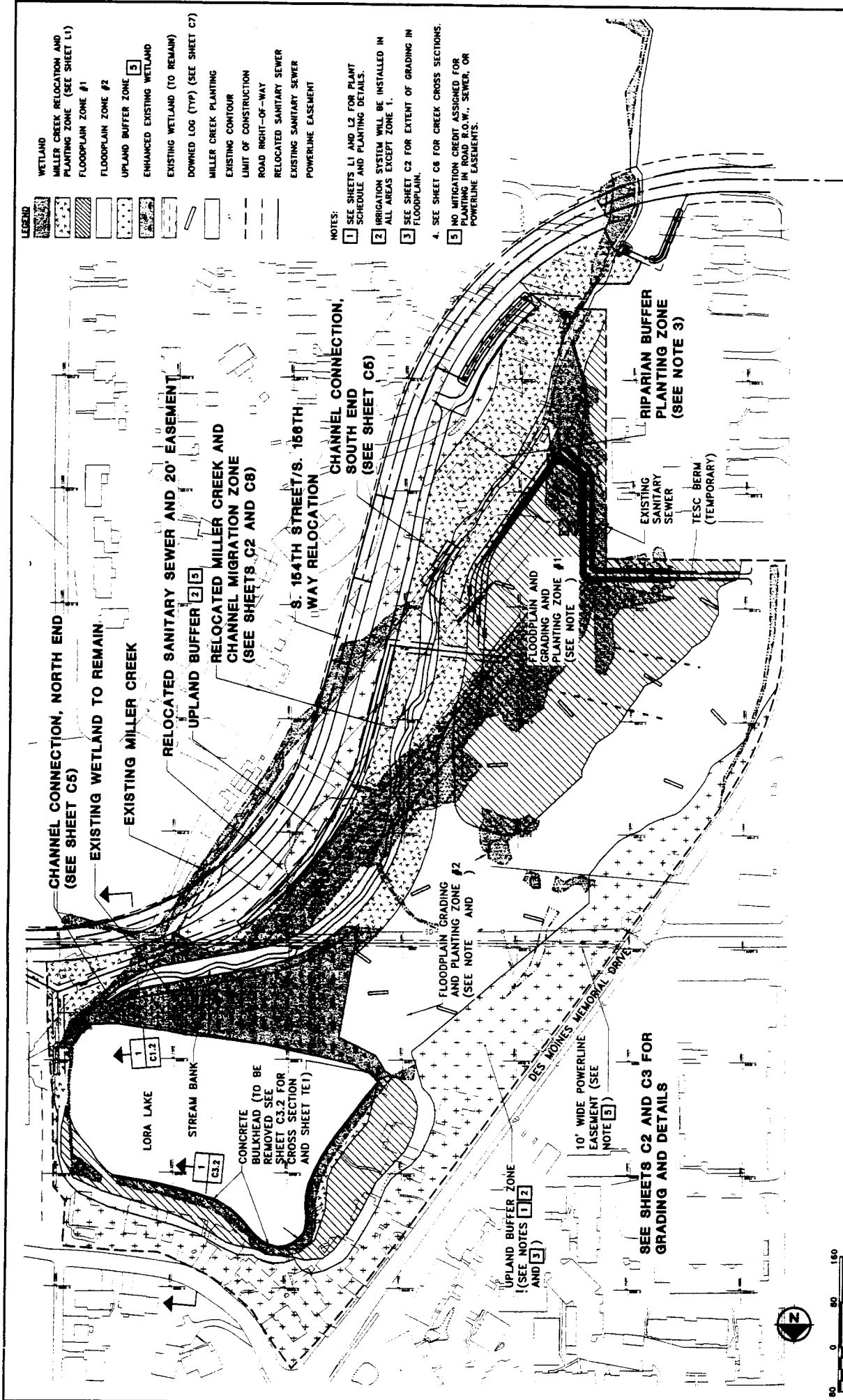
**Parimetrix**  
68A-TAC INTERNATIONAL AIRPORT  
MILLER CREEK RELOCATION  
SHEET NO. 281217C1  
DATE: 11/19/01

| NO. | DATE | DESCRIPTION |
|-----|------|-------------|
|     |      |             |
|     |      |             |
|     |      |             |
|     |      |             |

| NO. | DATE | DESCRIPTION |
|-----|------|-------------|
|     |      |             |
|     |      |             |
|     |      |             |
|     |      |             |

**Parimetrix, Inc.**  
5008 1st Washington Blvd. NE  
Kirkland, WA 98033  
Ph: (425) 822-8800

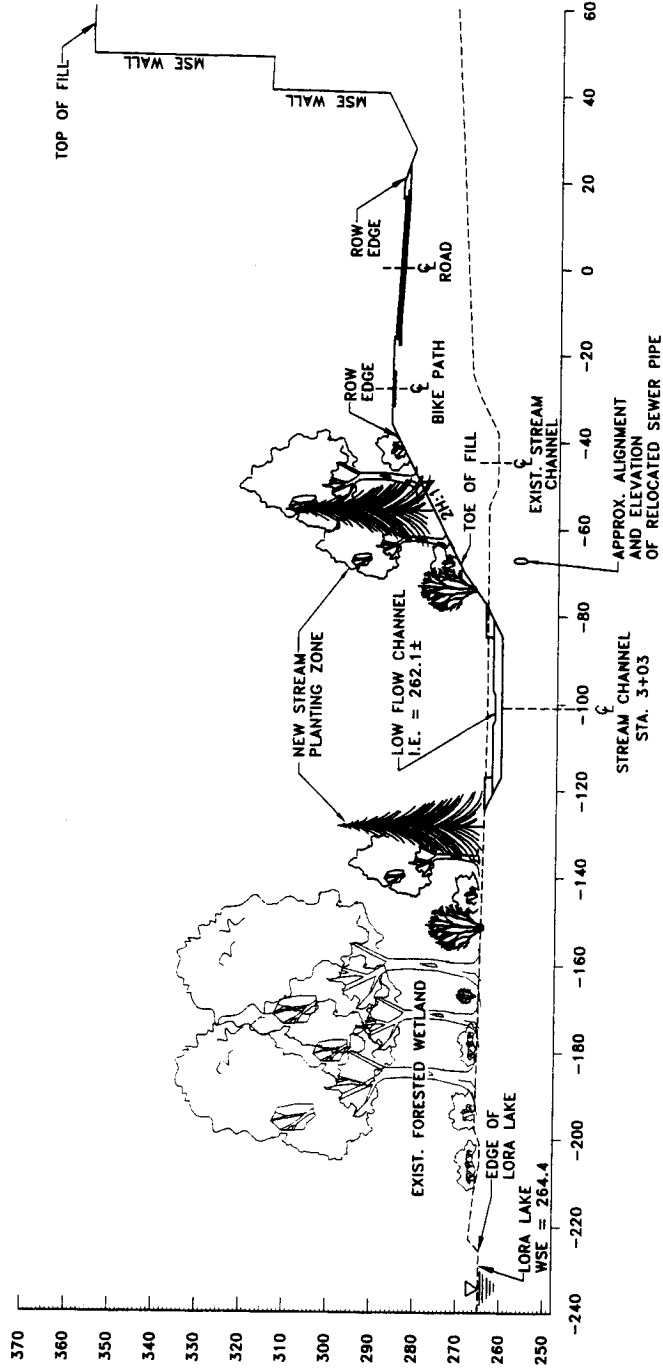
CALL 48 HOURS BEFORE YOU DIG 1-800-425-5555



**AGENCY REVIEW NOT FOR CONSTRUCTION**

|                                                                                                                                                                     |                                                                                                                                                                  |                                                                                                                    |                     |                  |                  |
|---------------------------------------------------------------------------------------------------------------------------------------------------------------------|------------------------------------------------------------------------------------------------------------------------------------------------------------------|--------------------------------------------------------------------------------------------------------------------|---------------------|------------------|------------------|
| <b>CALL 48 HOURS BEFORE YOU DIG</b><br>1-800-424-5555                                                                                                               | <b>Parametrix, Inc.</b><br>5808 Lk. Washington Blvd. NE<br>Kirkland, WA 98033<br>Ph: (425) 822-8080<br><small>Quality Service Through Employee Ownership</small> | <b>REVISIONS</b>                                                                                                   | <b>154ALDRN.DWG</b> | <b>SEWER.DWG</b> | <b>SD-SS.DWG</b> |
| <b>Port of Seattle</b><br><b>SEA-TAC INTERNATIONAL AIRPORT</b><br>PROJECT: MILLER CREEK RELOCATION<br>SHEET NO.: MILLER CREEK RELOCATION AND FLOODPLAIN ENHANCEMENT |                                                                                                                                                                  | DATE: 11/15/01<br>DRAWN: 201217C1-1<br>CHECKED: 100051<br>DATE PLOTTED: 201217C1-1<br>STA: 9805-C1.1<br>APPENDIX A |                     |                  |                  |

AR 049414



**SECTION**  
 MILLER CREEK CROSS SECTION  
 SCALE: 1" = 15'

|   |      |
|---|------|
| 1 | C1.1 |
|---|------|

**AGENCY REVIEW  
 NOT FOR CONSTRUCTION**

**Port of Seattle  
 SEA-TAC INTERNATIONAL AIRPORT  
 MILLER CREEK RELOCATION  
 CROSS SECTION MILLER CREEK RELOCATION AND  
 S. 164TH/S. 165TH ST. AT STREET STA. 108+60**

PROJECT NO. 100051  
 SHEET NO. 28121703-1  
 DATE 08/11/07

DESIGNED BY  
 CHECKED BY  
 APPROVED BY

DATE 08/11/07  
 FILENAME 28121703-1  
 SHEET NO.

REVISIONS

| NO. | DATE | BY | DESCRIPTION |
|-----|------|----|-------------|
|     |      |    |             |

SCALE: 1" = 15'

ONE INCH AT FULL SCALE  
 IF NOT SCALE ACCORDINGLY

DATE 08/11/07  
 FILENAME 28121703-1  
 SHEET NO.

PROJECT NO. 100051  
 SHEET NO. 28121703-1  
 DATE 08/11/07

DESIGNED BY  
 CHECKED BY  
 APPROVED BY

DATE 08/11/07  
 FILENAME 28121703-1  
 SHEET NO.

PROJECT NO. 100051  
 SHEET NO. 28121703-1  
 DATE 08/11/07

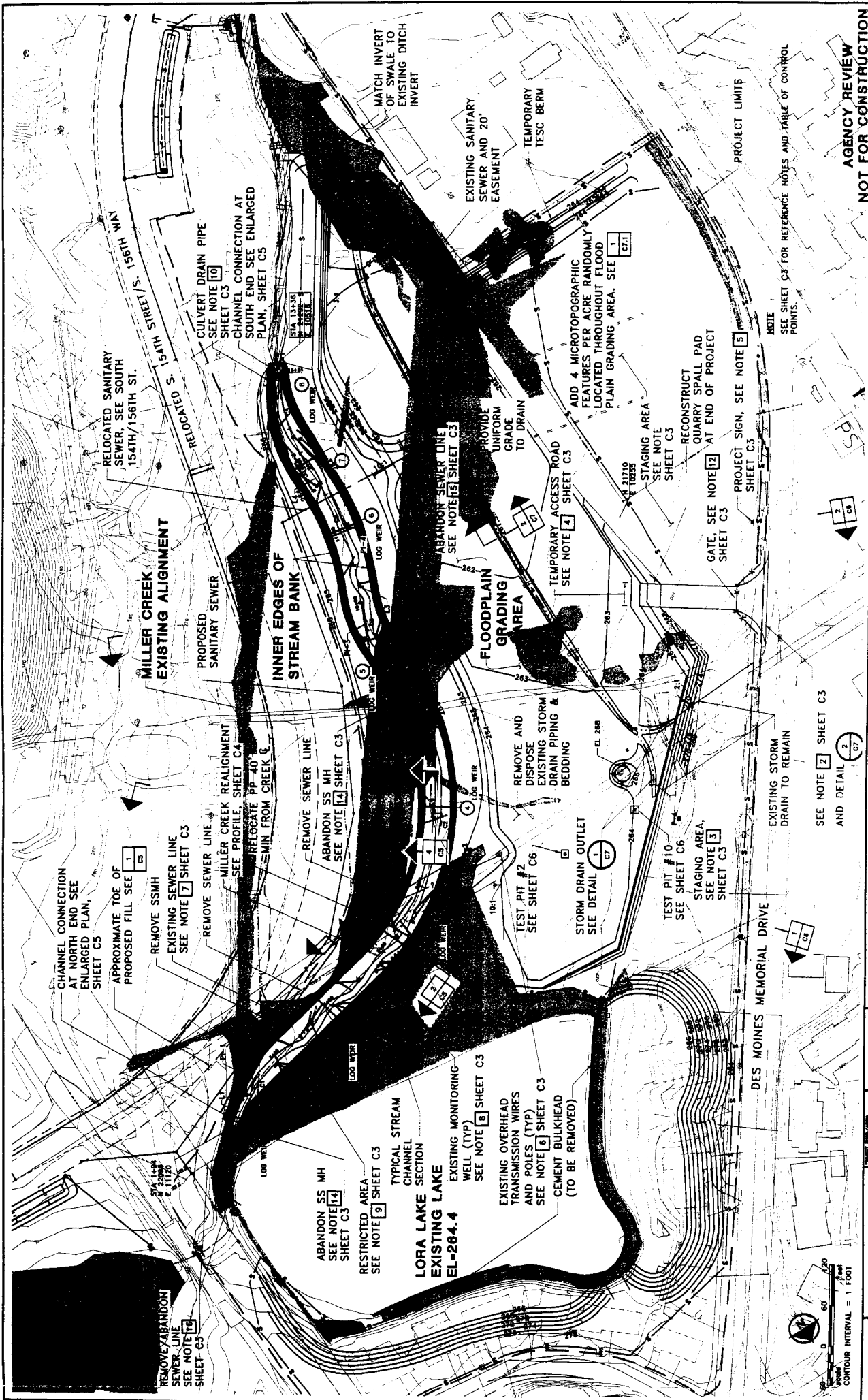
DESIGNED BY  
 CHECKED BY  
 APPROVED BY

DATE 08/11/07  
 FILENAME 28121703-1  
 SHEET NO.

PROJECT NO. 100051  
 SHEET NO. 28121703-1  
 DATE 08/11/07

DESIGNED BY  
 CHECKED BY  
 APPROVED BY

DATE 08/11/07  
 FILENAME 28121703-1  
 SHEET NO.



**NOT FOR CONSTRUCTION**

**AGENCY REVIEW**

**SEA-TAC INTERNATIONAL AIRPORT**  
**MILLER CREEK RELOCATION**  
**SITE PLAN**

| NO. | DATE | DESCRIPTION | BY | CHKD |
|-----|------|-------------|----|------|
|     |      |             |    |      |
|     |      |             |    |      |
|     |      |             |    |      |
|     |      |             |    |      |
|     |      |             |    |      |
|     |      |             |    |      |
|     |      |             |    |      |
|     |      |             |    |      |
|     |      |             |    |      |
|     |      |             |    |      |

**REVISIONS**

| NO. | DATE | DESCRIPTION | BY | CHKD |
|-----|------|-------------|----|------|
|     |      |             |    |      |
|     |      |             |    |      |
|     |      |             |    |      |
|     |      |             |    |      |
|     |      |             |    |      |
|     |      |             |    |      |
|     |      |             |    |      |
|     |      |             |    |      |
|     |      |             |    |      |
|     |      |             |    |      |

**Parametrix, Inc.**  
 5808 Lt. Washington Blvd. NE  
 Kirkland, WA 98033  
 Ph: (425) 822-8880

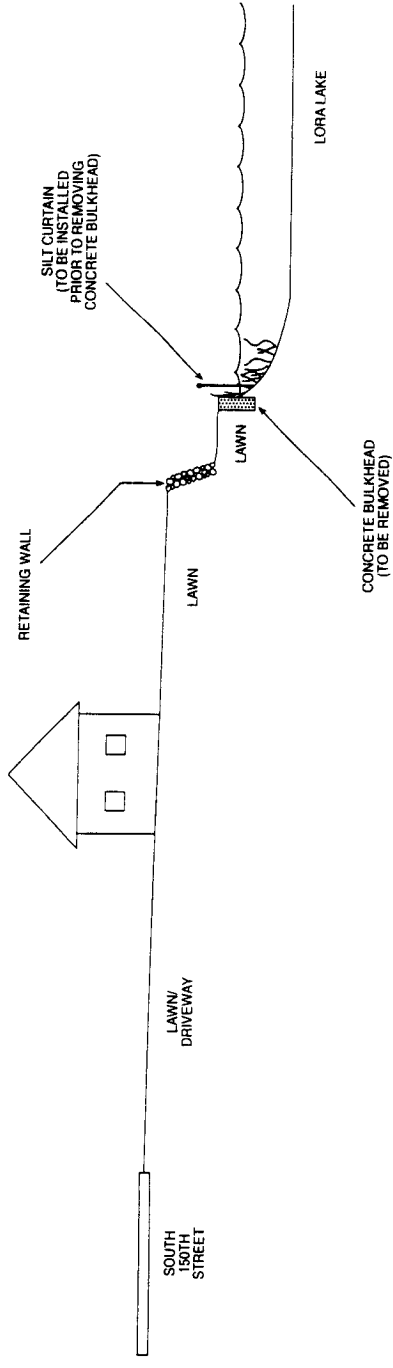
DATE: 10/09/01 FILENAME: 29121784.dwg SHEET: 29121784.00 OF 10 SHEETS  
 29121784.DWG  
 29121784.DWG  
 156.DWG

AR 049416

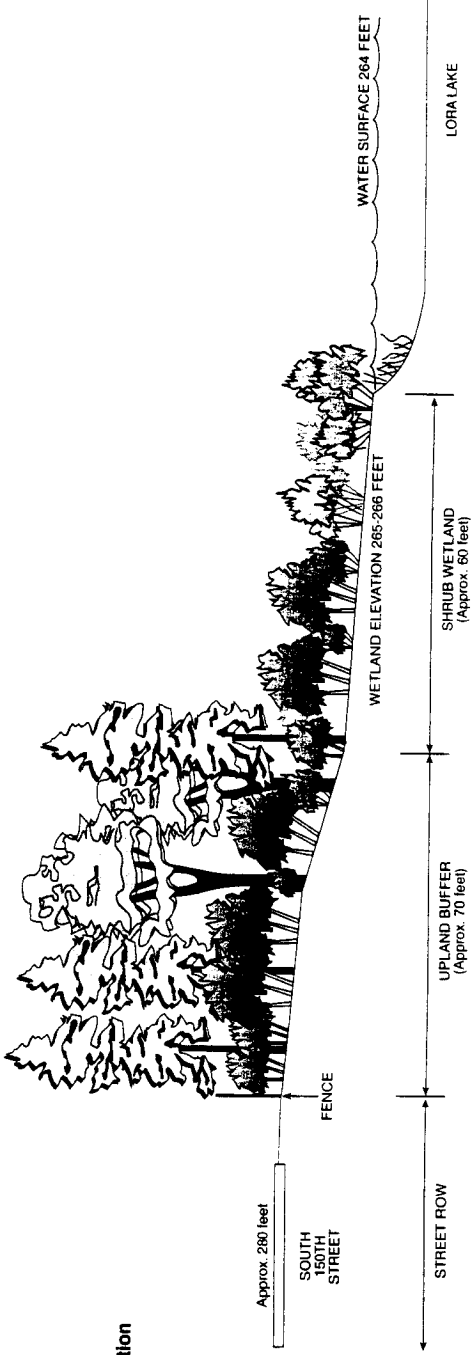




**Existing Conditions**



**Post-Mitigation**



CALL 48 HOURS BEFORE YOU DIG: 1-800-424-5555

**Parametrix, Inc.**  
 5900 N. Washington Blvd. NE  
 Kirkland, WA 98033  
 Ph: (425) 822-8800

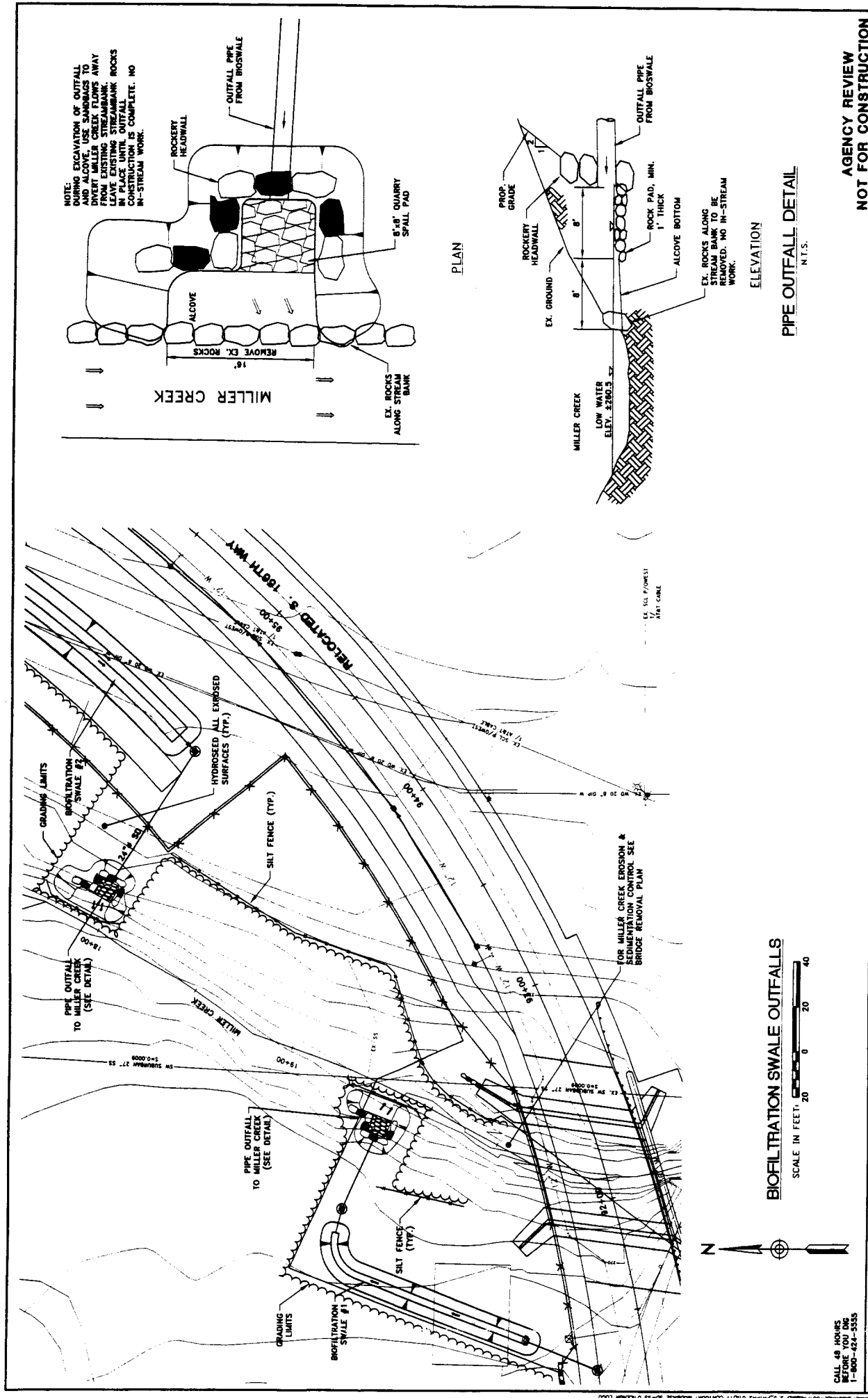
PROJECT: SEATTLE SEA-TAC INTERNATIONAL AIRPORT MILLER CREEK RELOCATION  
 SHEET NO. 201216.7  
 DATE: 5/14/2012  
 DRAWN BY: J. J. JENSEN  
 CHECKED BY: J. J. JENSEN  
 DATE: 5/14/2012

| NO. | REV. | REVISIONS |             |
|-----|------|-----------|-------------|
|     |      | DATE      | DESCRIPTION |
|     |      |           |             |
|     |      |           |             |
|     |      |           |             |
|     |      |           |             |
|     |      |           |             |
|     |      |           |             |
|     |      |           |             |
|     |      |           |             |
|     |      |           |             |

Port of Seattle  
 SEA-TAC INTERNATIONAL AIRPORT  
 MILLER CREEK RELOCATION  
 TYPICAL CROSS SECTION OF LORALAKE  
 WETLAND RESTORATION AND BUFFER

AGENCY REVIEW  
 NOT FOR CONSTRUCTION

10005.1  
 201216.7  
 5/14/2012  
 APPENDIX A



CALL 48 HOURS BEFORE YOU DIG  
1-800-424-3535

**KATON WARREN INCORPORATED**  
A Division of TransSystems Corporation  
2003 Western Avenue  
555 Market Place One  
Seattle, WA 98121  
(206) 448-4200

| NO. | DATE | BY | DESCRIPTION |
|-----|------|----|-------------|
|     |      |    |             |
|     |      |    |             |
|     |      |    |             |

| NO. | DATE | BY | DESCRIPTION |
|-----|------|----|-------------|
|     |      |    |             |
|     |      |    |             |
|     |      |    |             |

| NO. | DATE | BY | DESCRIPTION |
|-----|------|----|-------------|
|     |      |    |             |
|     |      |    |             |
|     |      |    |             |

| NO. | DATE | BY | DESCRIPTION |
|-----|------|----|-------------|
|     |      |    |             |
|     |      |    |             |
|     |      |    |             |

| NO. | DATE | BY | DESCRIPTION |
|-----|------|----|-------------|
|     |      |    |             |
|     |      |    |             |
|     |      |    |             |

| NO. | DATE | BY | DESCRIPTION |
|-----|------|----|-------------|
|     |      |    |             |
|     |      |    |             |
|     |      |    |             |

| NO. | DATE | BY | DESCRIPTION |
|-----|------|----|-------------|
|     |      |    |             |
|     |      |    |             |
|     |      |    |             |

**AGENCY REVIEW**  
**NOT FOR CONSTRUCTION**

**Port of Seattle**  
**SEA-TAC INTERNATIONAL AIRPORT**  
**MILLER CREEK RELOCATION**

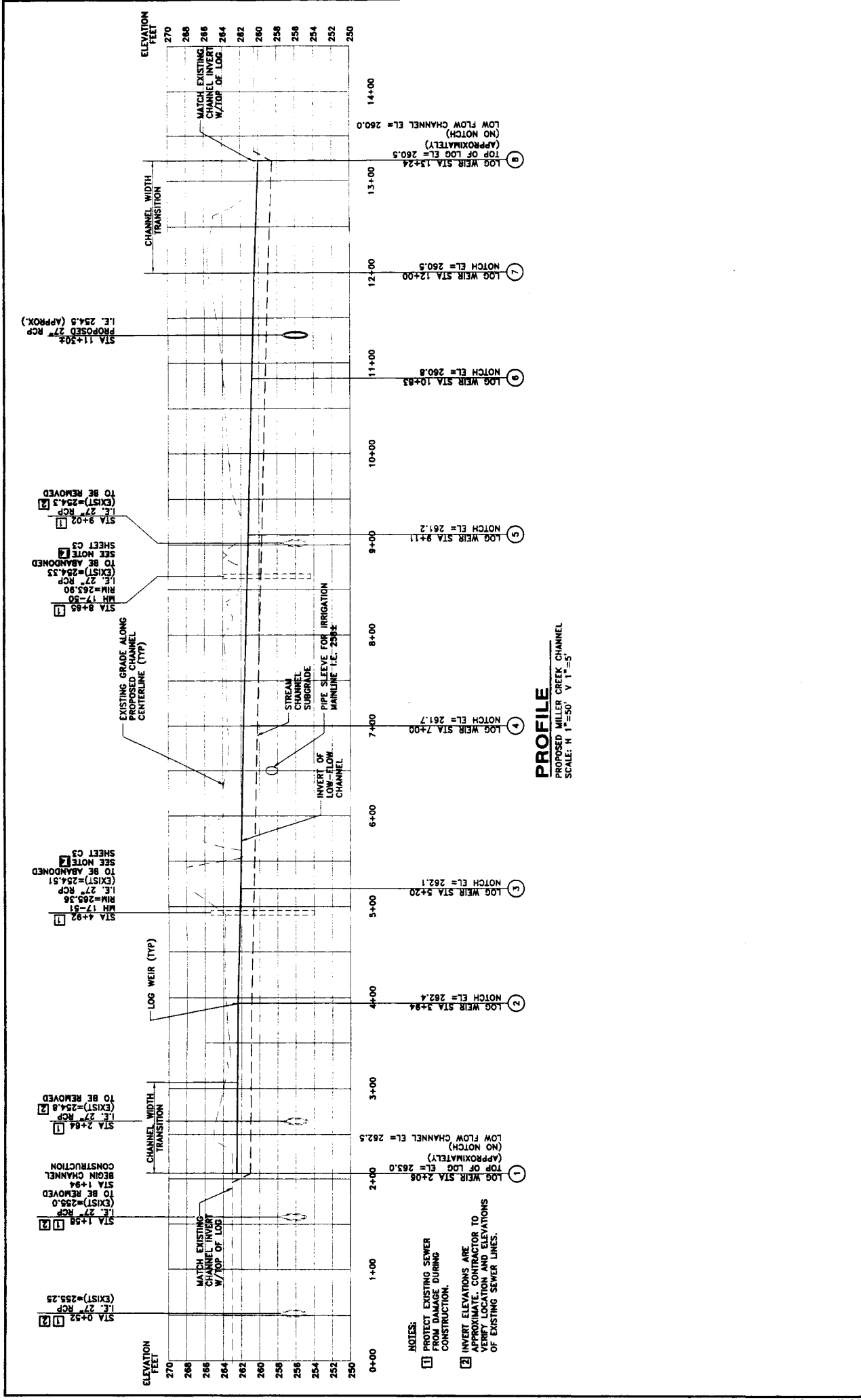
**PROJECT TITLE: BIOFILTRATION SWALE OUTFALLS**

DATE: 11/5/01  
DRAWN: BISHOP  
CHECKED: J. J. HARRIS  
SCALE: AS SHOWN  
SHEET NO.: 86-382  
PART OF SURVEY NO.: STA-9806-C3.3

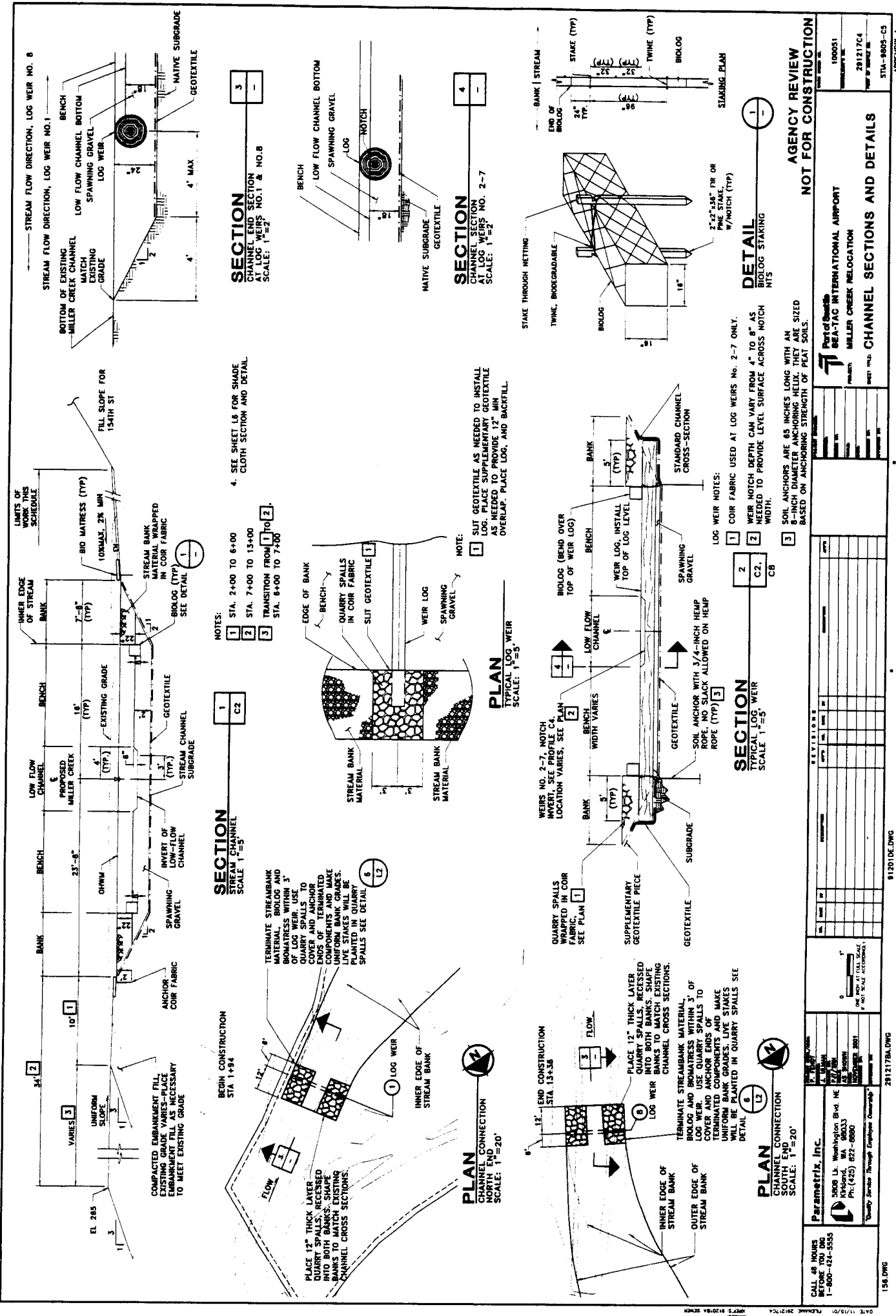


DATE: 11/13/07 PLOTTED: 2/17/08

AR 049421



|                                                                                                                                                                |      |                                                                                                |             |
|----------------------------------------------------------------------------------------------------------------------------------------------------------------|------|------------------------------------------------------------------------------------------------|-------------|
| <b>Parametrix, Inc.</b><br>8808 Lt. Northside Blvd. NE<br>Hickory, WA 98025<br>Ph: (425) 822-8800<br><small>Quality Service Through Employee Ownership</small> |      | I. DATE: 11/13/07<br>P. DATE: 11/13/07<br>I. BY: [Signature]<br>P. BY: [Signature]             |             |
| CALL US NOW!<br>GETTING YOU THE BEST!<br>1-800-424-5855                                                                                                        |      | I. PROJECT NO.: 100031<br>I. DRAWING NO.: 281217CRV<br>I. SHEET NO.: STA-8005-C4<br>APPENDIX A |             |
| PROJECT: SEA-TAC INTERNATIONAL AIRPORT<br>MILLER CREEK RELOCATION<br>CHANNEL PROFILE                                                                           |      |                                                                                                |             |
| REVISIONS                                                                                                                                                      |      |                                                                                                |             |
| NO.                                                                                                                                                            | DATE | BY                                                                                             | DESCRIPTION |
|                                                                                                                                                                |      |                                                                                                |             |
|                                                                                                                                                                |      |                                                                                                |             |
|                                                                                                                                                                |      |                                                                                                |             |
|                                                                                                                                                                |      |                                                                                                |             |



**NOTES:**

- 1 STA. 2+00 TO 6+00
- 2 STA. 7+00 TO 13+00
- 3 STA. 8+00 TO 7+00

4. SEE SHEET 16 FOR SHADE CLOTH SECTION AND DETAIL.

**SECTION CHANNEL END SECTION AT LOG WEIRS NO. 1 & NO. 8**  
SCALE: 1"=2'

**SECTION CHANNEL END SECTION AT LOG WEIRS NO. 2-7**  
SCALE: 1"=2'

**PLAN CHANNEL CONNECTION NORTH END**  
SCALE: 1"=20'

**PLAN CHANNEL CONNECTION SOUTH END**  
SCALE: 1"=20'

**DETAIL BIOLOG STAKING**  
SCALE: 1"=2'

**DETAIL STANDARD CHANNEL CROSS-SECTION**  
SCALE: 1"=2'

**LOG WEIR NOTES:**

- 1 COIR FABRIC USED AT LOG WEIRS NO. 2-7 ONLY.
- 2 WEIR NOTCH DEPTH CAN VARY FROM 4" TO 8" AS NEEDED TO PROVIDE LEVEL SURFACE ACROSS NOTCH WIDTH.
- 3 SOIL ANCHORS ARE 65 INCHES LONG WITH AN ANCHORING HEAD. THEY ARE SIZED BASED ON ANCHORING STRENGTH OF PEAT SOILS.

**AGENCY REVIEW NOT FOR CONSTRUCTION**

**Part of Order**  
**SEN-JAC INTERNATIONAL AIRPORT**  
**MILLER CREEK RELOCATION**  
**CHANNEL SECTIONS AND DETAILS**

DATE: 11/15/01  
 DRAWN BY: J. H. BROWN  
 CHECKED BY: J. H. BROWN  
 SCALE: 1"=20'

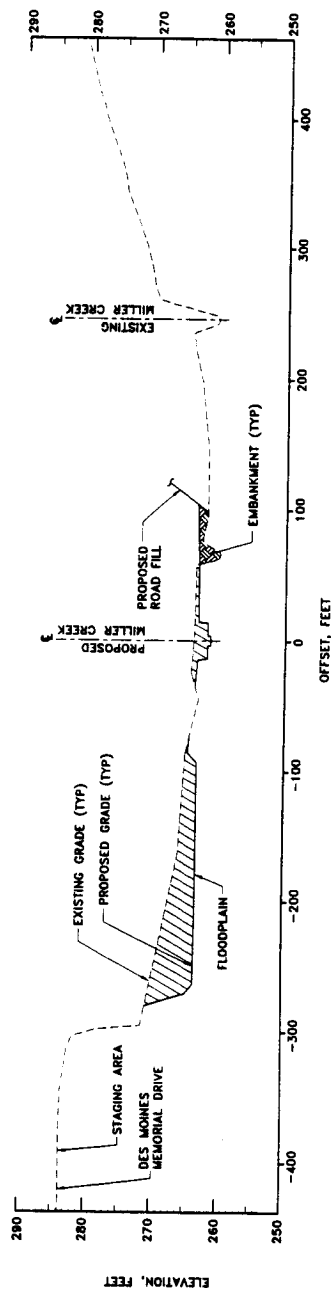
158.DWG  
 2912178A.DWG  
 912010E.DWG

CALL 48 HOURS BEFORE YOU DRK  
 1-800-424-5555

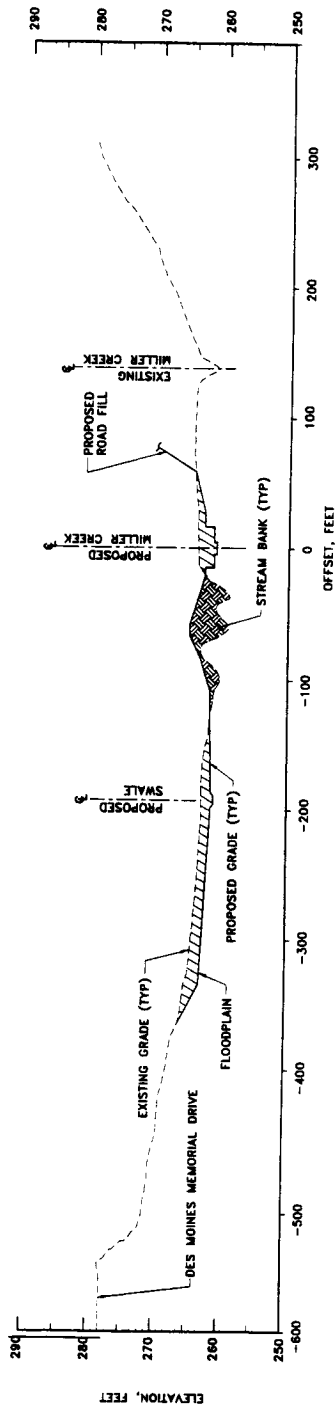
Parametrix, Inc.  
 5808 1st Washington Blvd. NE  
 Kirkland, WA 98033  
 Ph: (425) 872-8880

"Quality Service Through Employee Ownership"

AR 049422



**SECTION 1**  
 PROPOSED CROSS SECTION  
 AT STA. 6+50  
 SCALE: H 1" = 50' V 1" = 10'



**SECTION 2**  
 PROPOSED CROSS SECTION  
 AT STA. 10+13  
 SCALE: H 1" = 50' V 1" = 10'

AGENCY REVIEW  
 NOT FOR CONSTRUCTION

100051  
 201217C5  
 STA-9805-C6  
 APPENDIX A

Part of Seattle  
**SEA-TAC INTERNATIONAL AIRPORT**  
 MILLER CREEK RELOCATION  
 PROJECT  
 SHEET 1011 FLOODPLAIN SECTIONS

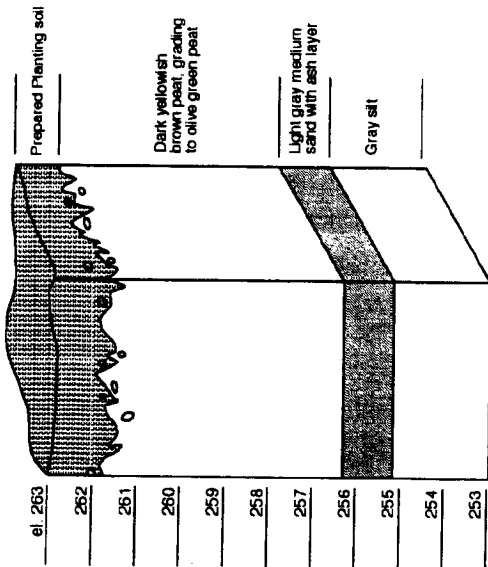
| NO. | DATE | BY | CHKD. | REVISIONS |
|-----|------|----|-------|-----------|
|     |      |    |       |           |

| NO. | DATE | BY | CHKD. | REVISIONS |
|-----|------|----|-------|-----------|
|     |      |    |       |           |

**Parametrix, Inc.**  
 5508 Lt. Washington Blvd. NE  
 Bellevue, WA 98006  
 Tel: (206) 835-8600  
 Fax: (206) 835-8601  
 Quality Service Through Employee Ownership

CALL US NOW!  
 BEFORE YOU DIG  
 1-800-424-5555

**Planting soil over peat subgrade**  
(Example based on proposed conditions near Test Pit #2')

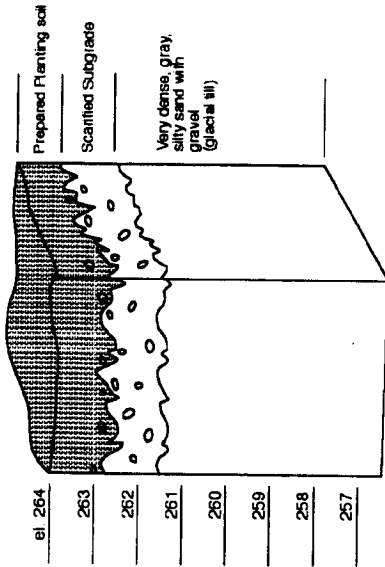


Where final grade is in peat deposits the subgrade will be over-excavated and 1 foot of planting soil will be placed over the peat.

- Excavate 12" below finish grade
- Place 12" prepared planting soil from stockpile
- Install plant materials

\*See Sheet C2 in Appendix A for test pit locations

**Planting soil over mineral soil subgrade**  
(Example based on proposed conditions near Test Pit #10')



Where final grade is in sand, gravel or glacial till deposits, the subgrade will be over-excavated and 1 foot of planting soil will be placed over the subgrade

- Excavate 12" below finish grade
- Scarify subgrade surface
- Place 12" prepared planting soil from stockpile
- Install plant materials

**AGENCY REVIEW**  
**NOT FOR CONSTRUCTION**

Port of Seattle  
SEA-TAC INTERNATIONAL AIRPORT  
MILLER CREEK RELOCATION  
SHEET TITLE: VACCA FARM FLOOD PLAN  
SOIL PROFILE

100051  
281217C6-1  
STA-8805-06.1

DATE: 11/13/01  
DRAWN: 281217C6-1  
REV: 5

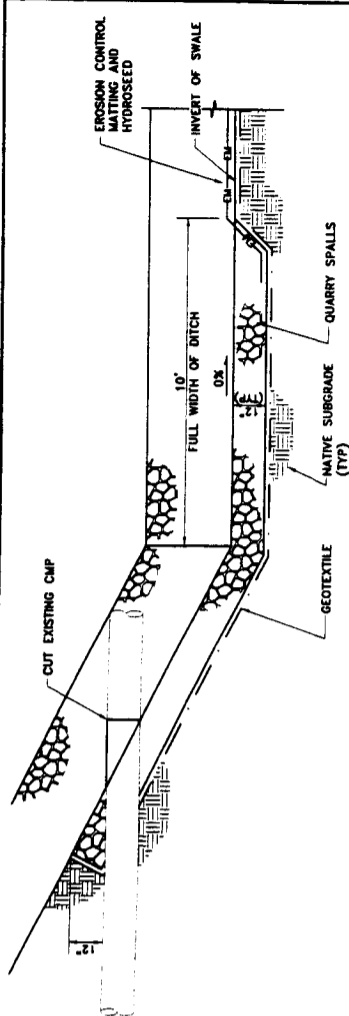
91201DE.DWG  
912017BA.DWG

CALL 48 HOURS BEFORE YOU GO  
1-800-424-5355

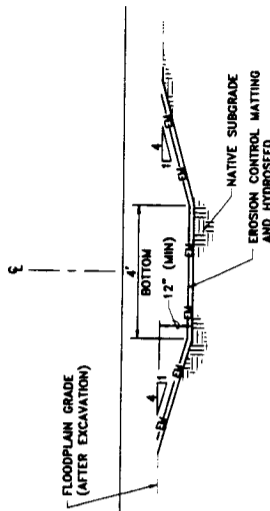
Parametrix, Inc.  
5008 Lk. Washington Blvd. NE  
Kirkland, WA 98033  
Ph: (425) 872-6800

QUALITY SERVICE THROUGH EMPLOYEE OWNERSHIP

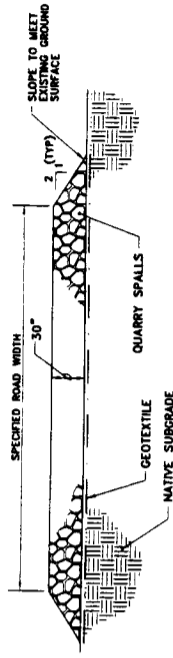
APPENDIX A



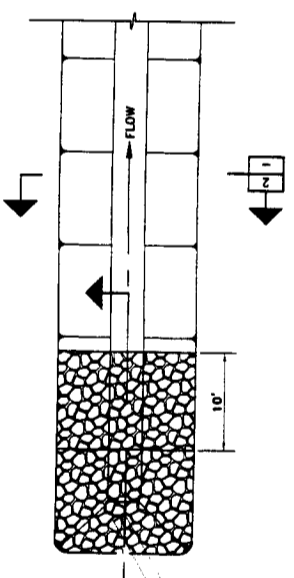
SECTION 1  
STORM DRAIN OUTLET  
SCALE: 1" = 2'



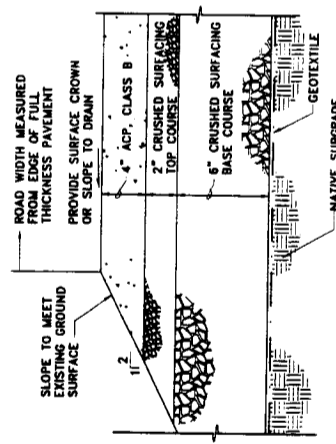
SECTION 2  
SCALE: 1" = 2'



SECTION 3  
TEMPORARY ASPHALT ROAD  
SCALE: 1" = 2'



DETAIL 1  
STORM DRAIN OUTLET  
N.T.S.



DETAIL 2  
TEMPORARY ASPHALT ROAD  
N.T.S.

CALL 48 HOURS BEFORE YOU INC 1-800-424-5555

**Parameterix, Inc.**  
5808 Lk. Washington Blvd. NE  
Kirkland, WA 98033  
Ph: (425) 872-8860

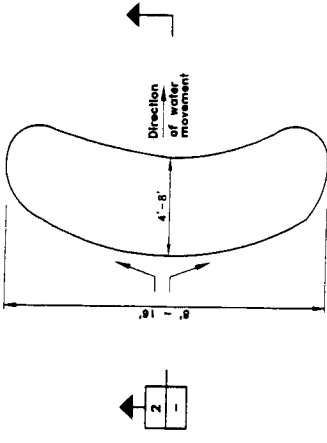
Quality Service Through Employee Ownership

DATE: 11/13/08  
SCALE: 2417/08  
SHEET NO: 100051  
PROJECT: MILLER CREEK RELOCATION  
SHEET TITLE: MISCELLANEOUS SECTIONS AND DETAILS  
STA: 9800-C7

AGENCY REVIEW  
**NOT FOR CONSTRUCTION**

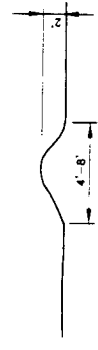
DESIGNER: [Signature]  
SCALE: 1" = 2'

AR 049426



**PLAN**  
N.T.S.

|   |    |
|---|----|
| 1 | C2 |
|---|----|



**SECTION**  
N.T.S.

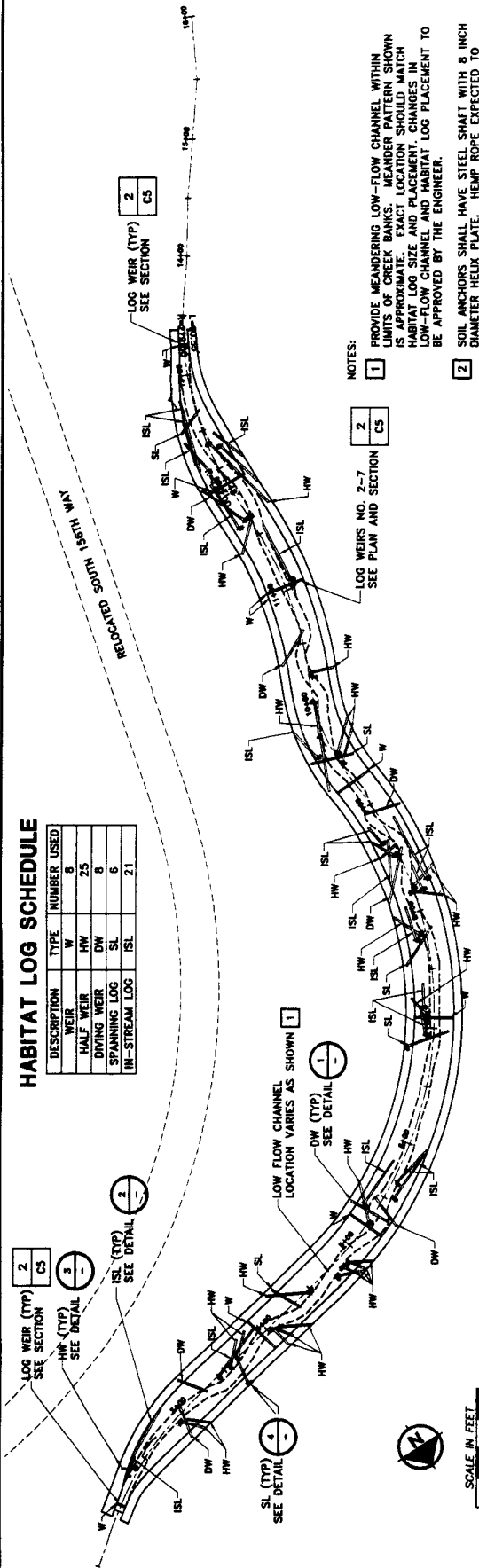
|   |   |
|---|---|
| 2 | - |
|---|---|

NOTE:  
1. MICROTOPOGRAPHIC FEATURES SHALL BE ORIENTED AS TO NOT IMPOUND WATER.

|                                                                                                                                                                         |                                                                                                                                                    |                                                                                        |               |                                                     |                                                 |                                                 |                                                 |                                       |
|-------------------------------------------------------------------------------------------------------------------------------------------------------------------------|----------------------------------------------------------------------------------------------------------------------------------------------------|----------------------------------------------------------------------------------------|---------------|-----------------------------------------------------|-------------------------------------------------|-------------------------------------------------|-------------------------------------------------|---------------------------------------|
| CALL 48 HOURS BEFORE YOU RIG<br>1-800-424-5555                                                                                                                          | <b>Parametrix, Inc.</b><br>5808 1/2 Newington Blvd. NE<br>Kirkland, WA 98033<br>Ph: (425) 822-8800<br>"Quality Service Through Employee Ownership" | P.C. TRACY<br>A. WILSON<br>12/7/91<br>A.E. SPOONER<br>12/10/91<br>2001<br>2001<br>2001 | 1"<br>0<br>1" | S E V I R I O U S                                   |                                                 |                                                 |                                                 | 100051<br>291217C7-1<br>STA-9805-C7.1 |
|                                                                                                                                                                         |                                                                                                                                                    |                                                                                        |               | DATE: 11/13/91<br>DRAWN: 291217C7-1<br>CHECKED:     | DATE: 11/13/91<br>DRAWN: 291217C7-1<br>CHECKED: | DATE: 11/13/91<br>DRAWN: 291217C7-1<br>CHECKED: | DATE: 11/13/91<br>DRAWN: 291217C7-1<br>CHECKED: |                                       |
| Part of Seattle<br><b>SEA-TAC INTERNATIONAL AIRPORT</b><br>MILLER CREEK RELOCATION<br>PROJECT: MILLER CREEK RELOCATION<br>SHEET NO.: MICROTOPOGRAPHIC FEATURE<br>DETAIL |                                                                                                                                                    |                                                                                        |               | <b>AGENCY REVIEW</b><br><b>NOT FOR CONSTRUCTION</b> |                                                 |                                                 |                                                 |                                       |

### HABITAT LOG SCHEDULE

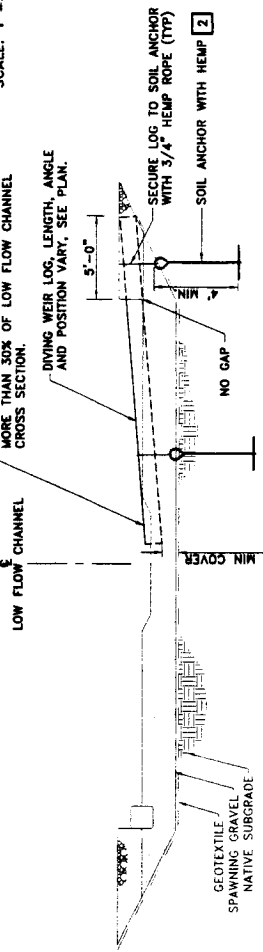
| DESCRIPTION   | TYPE | NUMBER USED |
|---------------|------|-------------|
| WEIR          | W    | 8           |
| HALF WEIR     | HW   | 25          |
| DIVING WEIR   | DW   | 8           |
| SPANNING LOG  | SL   | 6           |
| IN-STREAM LOG | ISL  | 21          |



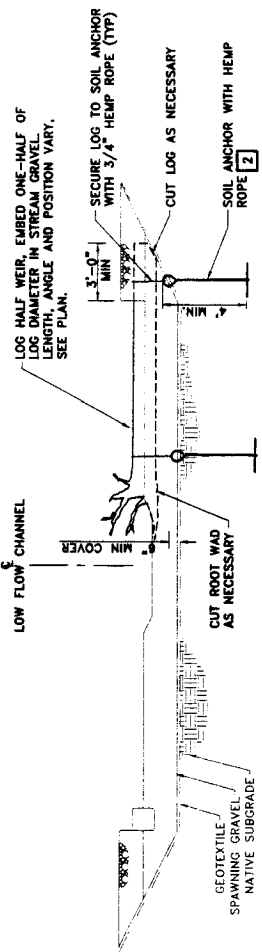
- NOTES:
- 1 PROVIDE MEANDERING LOW-FLOW CHANNEL WITHIN LIMITS OF CHECK BANK. MEMBER PATTERNS SHOWN IS APPROXIMATE. EXACT LOCATION SHOULD MATCH HABITAT LOG SIZE AND PLACEMENT. CHANGES IN LOW-FLOW CHANNEL AND HABITAT LOG PLACEMENT TO BE APPROVED BY THE ENGINEER.
  - 2 SOIL ANCHORS SHALL HAVE STEEL SHAFT WITH 8 INCH DIAMETER. HEMP ROPE SHALL BE 3/4" HEMP ROPE EXPECTED TO REMAIN IN PLACE 3 TO 5 YEARS.

### PLAN HABITAT LOG PLACEMENT SCALE: 1"=50'

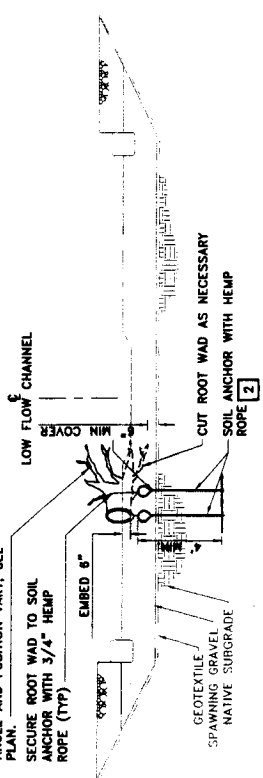
DO NOT OBSTRUCT LESS THAN 20% OR MORE THAN 30% OF LOW FLOW CHANNEL CROSS SECTION.



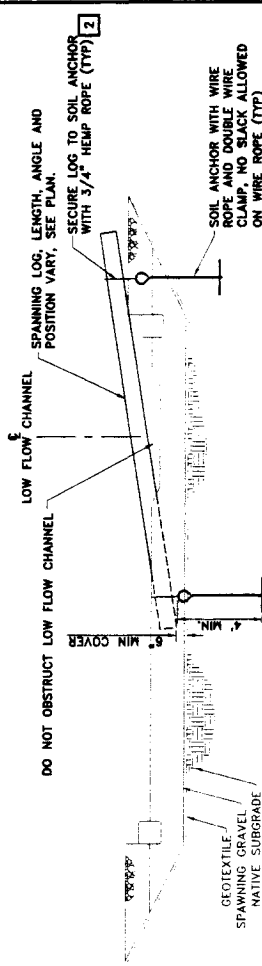
### DETAIL DW - DIVING WEIR N.T.S.



### DETAIL HW - HALF WEIR N.T.S.



### DETAIL ISL - IN-STREAM LOG N.T.S.



### DETAIL SL - SPANNING LOG N.T.S.

CALL 48 HOURS BEFORE YOU DIG  
1-800-424-3558

**Paramatrix, Inc.**  
5808 Lt. Washington Blvd. NE  
Kirkland, WA 98033  
PH: (425) 822-8820  
Quality Service Through Employee Ownership  
P. 12/07

Part of Seattle  
**SEA-TAC INTERNATIONAL AIRPORT**  
SOUTH 164TH STREET/169TH WAY/  
HALLMARK RELOCATION  
**HABITAT LOG - LAYOUT PLAN AND DETAILS**

DATE: 11/17/01  
DRAWN: S. PETER  
CHECKED: S. PETER  
SCALE: 1"=50'

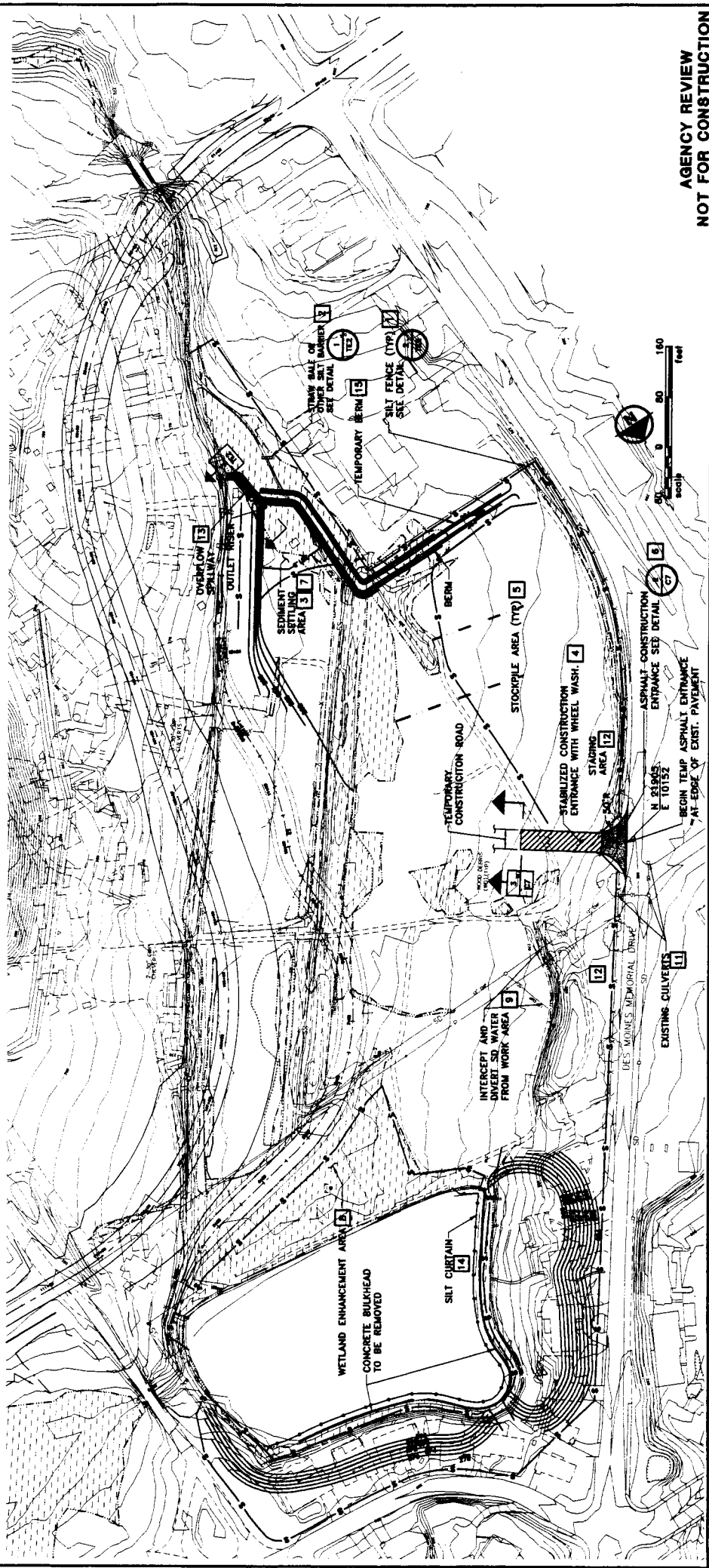
PROJECT NO: 100051  
DRAWING NO: 201217C7  
DATE OF PLOT: 11/17/01  
SHEET NO: 21 OF 21

STATION: STA-9805-C8  
APPENDIX A

AR 049427

**NOTES:**

- 1 INSTALL SILT FENCE PRIOR TO CONSTRUCTION ACTIVITIES. IN ADDITION TO SILT FENCE SHOWN, PROVIDE ADDITIONAL SILT FENCE AS DIRECTED BY ENGINEER. MAINTAIN SILT FENCE FOR DURATION OF PROJECT. PROTECT MILLER CREEK FROM SEDIMENT AND SEDIMENT LOADED SURFACE WATER RUNOFF, AND EROSION FROM CONSTRUCTION ACTIVITIES.
- 2 INSTALL SILT BARRIERS AT ALL LOCATIONS WHERE WATER DRAINS FROM PROJECT. INSTALL ADDITIONAL SILT BARRIERS ALONG SWALE IMMEDIATELY AFTER PORTIONS OF THE FLOOD PLAN SWALE AREA ARE EXCAVATED. SEE SHEETS C2 FOR LOCATION OF FLOOD PLAN SWALE.
- 3 CONSTRUCT TEMPORARY SEDIMENT SETTLING AREA TO GRADES SHOWN WITH BERMS, OUTLET AND SPILLWAY PRIOR TO EXCAVATION OR DEWATERING ACTIVITIES.
- 4 INSTALL AND MAINTAIN STABILIZED CONSTRUCTION ENTRANCE AND WHEEL WASH. ROUTE ALL HAUL VEHICLES ACROSS WHEEL WASH PRIOR TO LEAVING SITE. STABILIZED CONSTRUCTION ENTRANCE AND WHEEL WASH SHALL BE REMOVED AND AREA RESTORED AT END OF PROJECT.
- 5 PROVIDE SILT FENCE AROUND ALL STOCKPILE AREAS.
- 6 KEEP ASPHALT SURFACE CLEAN AND FREE OF SEDIMENT AT ALL TIMES W/VACUUM SWEEPER. HO STONE, MUD OR SEDIMENT SHALL BE TRACKED OUT ONTO DES MORNES WAY SOUTH. PAVED ENTRANCE SHALL BE REMOVED OR AS DIRECTED BY ENGINEER AND AREA RESTORED AT END OF PROJECT.
- 7 ALL DEWATERING WATER AND STORM WATER RUNOFF FROM DISTURBED AREAS SHALL BE ROUTED THROUGH SEDIMENT SETTLING AREA. WATER WILL BE PUMPED FROM SEDIMENT SETTLING AREA TO POND C FOR TREATMENT BEFORE DISCHARGE. POND C IS LOCATED SOUTH OF PROJECT AREA BETWEEN EXISTING S. 156TH WAY AND S. 157TH ST.
- 8 PROVIDE SILT FENCE ALONG WETLAND ENHANCEMENT AREA. SEE NOTE 9 SHEET C3 FOR ACCESS RESTRICTIONS TO THIS AREA.
- 9 PROVIDE PLAN TO INTERCEPT AND DIVERT ALL STORM DRAIN (SD) WATER FROM ENTERING THE WORK AREA. PLAN TO BE APPROVED BY ENGINEER.
- 10 CONTRACTOR SHALL SUBMIT PLAN FOR SEQUENCING CONSTRUCTION ACTIVITIES TO CONTROL SEDIMENT AND EROSION, OPERATING SEDIMENT SETTLING AREA, DIVERTING MILLER CREEK FLOWS, AND RE-INTRODUCING WATER TO THE NEW PORTION OF MILLER CREEK. SEE SPECIFICATIONS, SECTION 8-37.
- 11 CONTRACTOR SHALL PLACE NON-WOVEN GEOTEXTILE BETWEEN EXISTING CATCH BASIN OPENING AND GRATE TO PROTECT FROM SEDIMENT.
- 12 CONTRACTOR'S EMPLOYEE PARKING AREA SHALL BE ADJACENT TO ENTRANCE, AND AREA SHALL BE CONSTRUCTED AT A MINIMUM OF 8" CRUSHED ROCK OVER A GEOTEXTILE FABRIC. CONTRACTOR SHALL RESTORE AREA AT END OF PROJECT.
- 13 OVERFLOW SPILLWAY, OUTLET, RISER, AND PORTION OF BERM SHALL BE REMOVED AND RESTORED AT END OF MILLER CREEK PROJECT.
- 14 PROVIDE SILT CURTAIN PRIOR TO REMOVAL OF BULKHEAD. MAINTAIN SILT CURTAIN UNTIL ALL GRADING OPERATIONS ARE COMPLETED AROUND LORA LAKE AND BANK IS STABILIZED.
- 15 TEMPORARY BERM TO BLOCK EXISTING DRAINAGE DITCH AND PREVENT SEDIMENT MIGRATION. RESTORE TO PRE-CONSTRUCTION GRADE AFTER FLOODPLAIN AREA IS STABILIZED.
- 16 BUILDINGS SHOWN WITH "X" HAVE BEEN OR WILL BE REMOVED BY THE PORT OF SEATTLE.



**AGENCY REVIEW  
NOT FOR CONSTRUCTION**

**Port of Seattle  
SEA-TAC INTERNATIONAL AIRPORT  
MILLER CREEK RELOCATION  
TEMPORARY EROSION AND  
SEDIMENT CONTROL PLAN**

|     |      |    |             |
|-----|------|----|-------------|
| NO. | DATE | BY | DESCRIPTION |
|     |      |    |             |
|     |      |    |             |
|     |      |    |             |

**REVISIONS**

|     |      |    |             |
|-----|------|----|-------------|
| NO. | DATE | BY | DESCRIPTION |
|     |      |    |             |
|     |      |    |             |
|     |      |    |             |

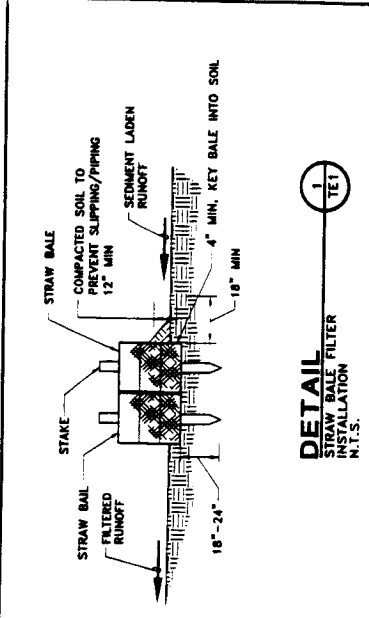
**PARAMETRIX, Inc.**  
 5808 U.S. Washington Blvd. NE  
 Kirkland, WA 98033  
 Ph: (425) 822-8800  
 "Quality Service Through Employee Ownership"

**CALL 48 HOURS  
BEFORE YOU DIG  
1-800-424-5555**

DATE: 11/17/07    DRAWING: 28127TE1  
 SCALE: 1"=40'    PROJECT: MILLER CREEK RELOCATION  
 SHEET NO.: 28127TE1  
 STA-9803-TE1  
 APPENDIX A

AR 049428

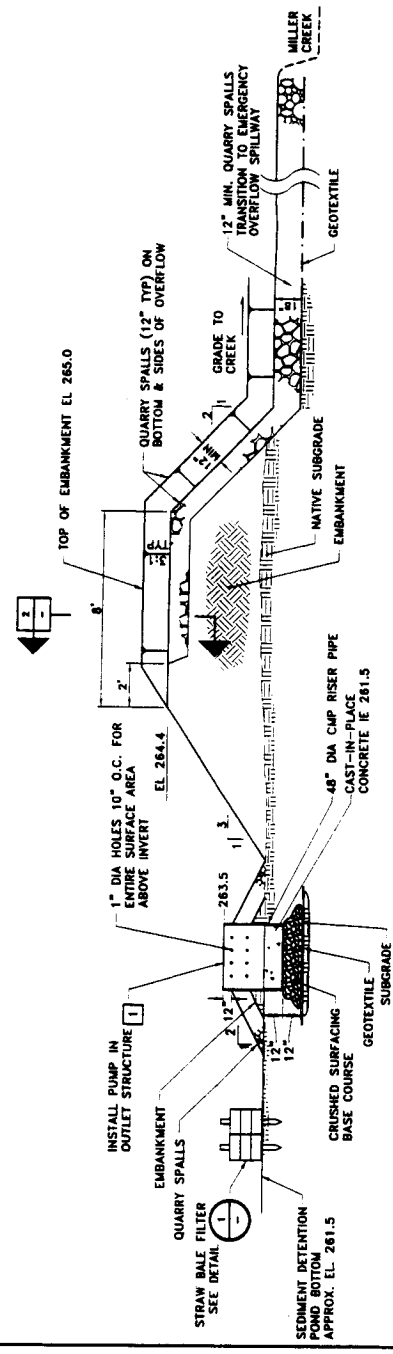




**DETAIL**  
 STRAW BALE FILTER  
 N.T.S.  
 1  
 TE1

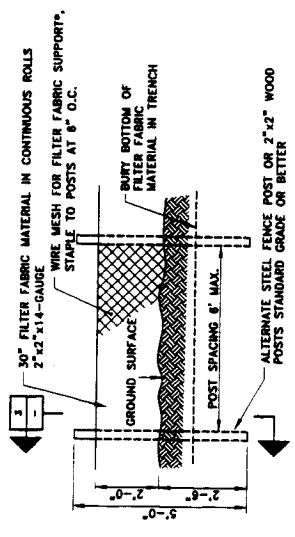
**NOTES:**

1. PROVIDE TWO ROWS OF STRAW BALES TO BLOCK SWALE (DITCH), STAGGER BUTT JOINTS BETWEEN ROWS.
2. STAKES SHALL BE REBAR STEEL PICKETS OR 3/4" WOOD STAKES, 2 PER BALE. ANGLE FIRST STAKE TOWARDS PREVIOUSLY LAYED BALE. SECOND STAKE VERTICAL ON ADJOINING BALES. TIE STAKES TOGETHER WITH WIRE.
3. INSTALL BALES FULL WIDTH OF SWALE, OR AS DIRECTED BY ENGINEER.

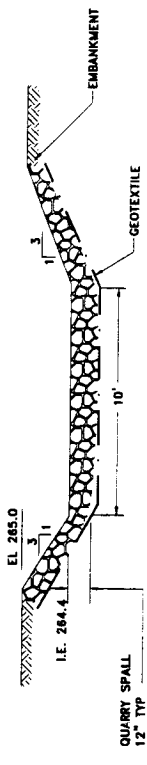


**SECTION**  
 EMERGENCY OVERFLOW SPILLWAY  
 N.T.S.  
 1  
 TE1

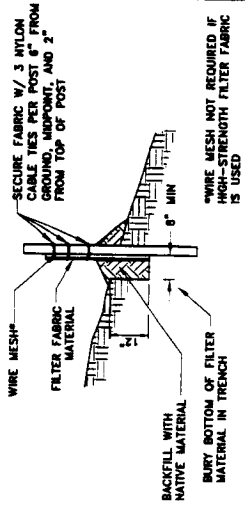
- NOTE:**
1. INSTALL PUMP WITH 100 GPM MIN. CAPACITY. PUMP TO KEEP WATER LEVEL BELOW EL. 263.5 AT ALL TIMES DURING CONSTRUCTION. PUMP WATER TO SEDIMENTATION POND C.



**DETAIL**  
 SILT FENCE  
 N.T.S.  
 2  
 TE1



**SECTION**  
 EMERGENCY OVERFLOW SPILLWAY  
 N.T.S.  
 2



**SECTION**  
 SILT FENCE  
 N.T.S.  
 3

**AGENCY REVIEW**  
**NOT FOR CONSTRUCTION**

Parametrix, Inc.  
 2808 L.I. Washington Blvd. NE  
 Redmond, WA 98053  
 Ph: (425) 882-6888  
 Quality Service Through Employee Ownership

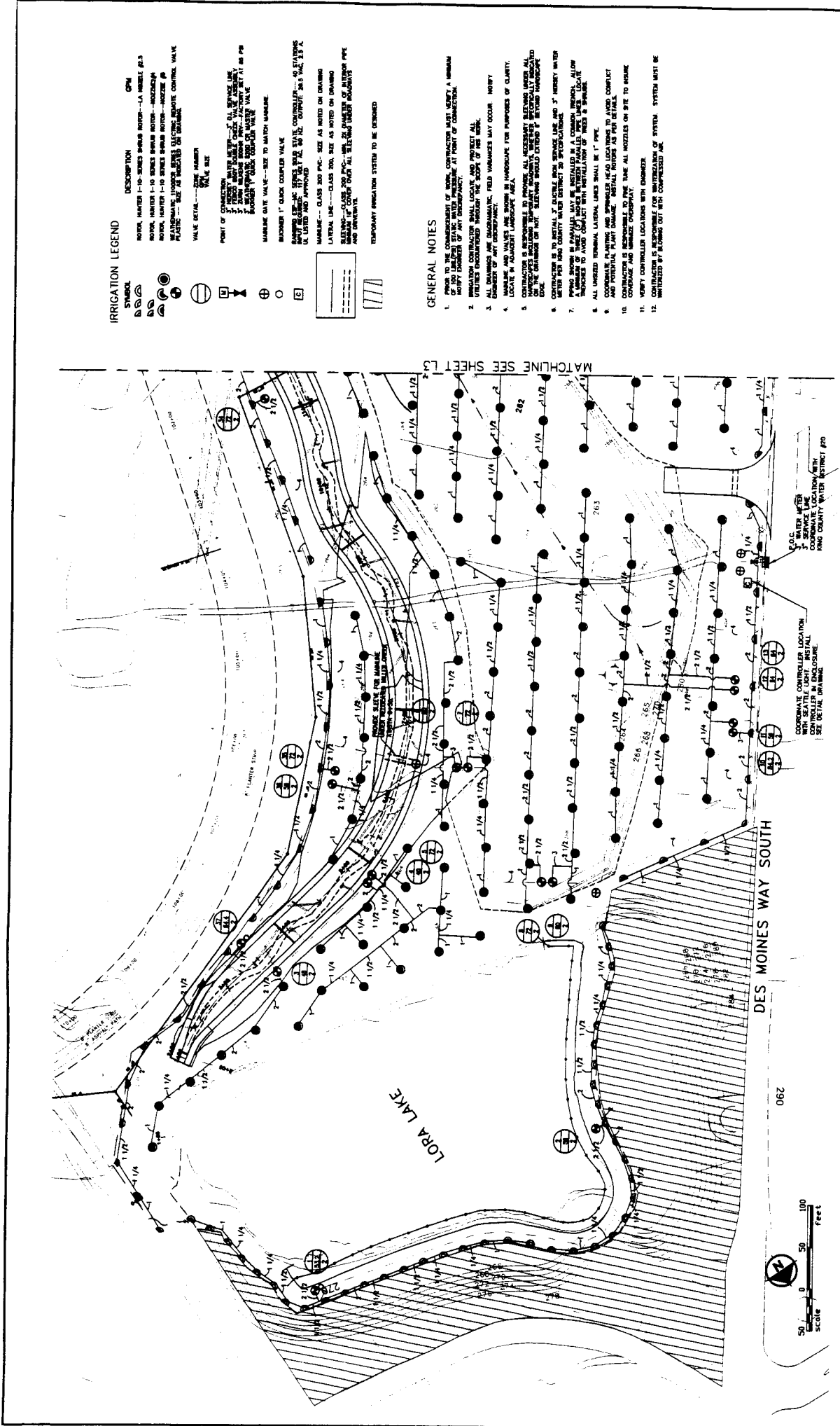
BEA-TAC INTERNATIONAL AIRPORT  
 MILLER CREEK RELOCATION  
 PROJECT NO. 20131712Z  
 DRAWING NO. STA-9903-TE2

| REV | DATE | BY | CHKD | DESCRIPTION |
|-----|------|----|------|-------------|
|     |      |    |      |             |
|     |      |    |      |             |
|     |      |    |      |             |
|     |      |    |      |             |
|     |      |    |      |             |

CALL 48 HOURS BEFORE CONSTRUCTION STARTS  
 1-800-424-8835

DATE: 11/13/09 PLENM: 20131712Z  
 SHEET NO. 100051  
 APPENDIX A





**IRRIGATION LEGEND**

| SYMBOL | DESCRIPTION                                                                                                            | QTY       |
|--------|------------------------------------------------------------------------------------------------------------------------|-----------|
|        | 1-1/2" SERIES SHANK ROTOR                                                                                              | LA 100000 |
|        | 1-1/2" SERIES SHANK ROTOR WITH NOZZLE                                                                                  | LA 100000 |
|        | 1-1/2" SERIES SHANK ROTOR WITH NOZZLE AND FILTER                                                                       | LA 100000 |
|        | 1-1/2" SERIES SHANK ROTOR WITH NOZZLE AND FILTER AND BACKFLOW PREVENTER                                                | LA 100000 |
|        | 1-1/2" SERIES SHANK ROTOR WITH NOZZLE AND FILTER AND BACKFLOW PREVENTER AND CONTROLLER                                 | LA 100000 |
|        | 1-1/2" SERIES SHANK ROTOR WITH NOZZLE AND FILTER AND BACKFLOW PREVENTER AND CONTROLLER AND VALVE                       | LA 100000 |
|        | 1-1/2" SERIES SHANK ROTOR WITH NOZZLE AND FILTER AND BACKFLOW PREVENTER AND CONTROLLER AND VALVE AND RISER             | LA 100000 |
|        | 1-1/2" SERIES SHANK ROTOR WITH NOZZLE AND FILTER AND BACKFLOW PREVENTER AND CONTROLLER AND VALVE AND RISER AND EMITTER | LA 100000 |

**GENERAL NOTES**

1. PRIOR TO THE COMMENCEMENT OF WORK, CONTRACTOR MUST VERIFY A MINIMUM 10' DEPTH OF COVER FOR ALL EXISTING UTILITY LINES AT POINT OF CONNECTION.
2. IRRIGATION CONTRACTOR SHALL LOCATE AND PROTECT ALL UTILITIES ENCOUNTERED THROUGH THE SCOPE OF THE WORK.
3. ALL VALVES AND CONTROLLERS SHALL BE INSTALLED IN ACCORDANCE WITH THE IRRIGATION CONTRACTOR'S STANDARD PRACTICES AND SHALL BE FIELD VERIFIED FOR PROPER OPERATION.
4. MAINLINE AND VALVES ARE SHOWN IN HANDICAPED FOR PURPOSES OF CLARITY.
5. CONTRACTOR IS RESPONSIBLE TO PROVIDE ALL NECESSARY BULKHEAD LANTERNS ALL OVER THE COURSE OF THE WORK TO MAINTAIN PROPER SAFETY AND VISIBILITY AT ALL TIMES.
6. CONTRACTOR SHALL PROVIDE ALL NECESSARY BULKHEAD LANTERNS AT ALL TIMES.
7. PIPING SHOWN IN PARALLEL MAY BE INSTALLED IN A COMMON TRENCH. ALLOW 18" CLEARANCE BETWEEN PARALLEL PIPING.
8. ALL UNDESIRED TERMINAL LATERAL LINES SHALL BE 1" PIPE.
9. COORDINATE PLANTING AND SPRINKLER HEAD LOCATIONS TO AVOID CONFLICT AND POTENTIAL PLANT DAMAGE. INSTALL ROTORS AS PER DETAILS.
10. CONTRACTOR IS RESPONSIBLE TO TAKE TIME TO TAKE ALL NOZZLES ON SITE TO INSURE PROPER OPERATION.
11. VERIFY CONTROLLER LOCATIONS WITH OWNER.
12. CONTRACTOR IS RESPONSIBLE TO PROVIDE ALL NECESSARY BULKHEAD LANTERNS AT ALL TIMES.

**AGENCY REVIEW  
NOT FOR CONSTRUCTION**

|               |             |
|---------------|-------------|
| PROJECT NO.   | 29121712    |
| DATE OF SHEET | 2012/12/12  |
| STATION       | STA-9805-L3 |

**Part of Seattle  
SEA-TAC INTERNATIONAL AIRPORT  
MILLER CREEK RELOCATION  
IRRIGATION PLAN N**

| NO. | REVISION         | DATE     |
|-----|------------------|----------|
| 1   | ISSUE FOR PERMIT | 12/12/12 |

|             |                  |
|-------------|------------------|
| DESIGNED BY | PROJECT ENGINEER |
| CHECKED BY  | DATE             |
| DRAWN BY    | DATE             |
| SCALE       | DATE             |

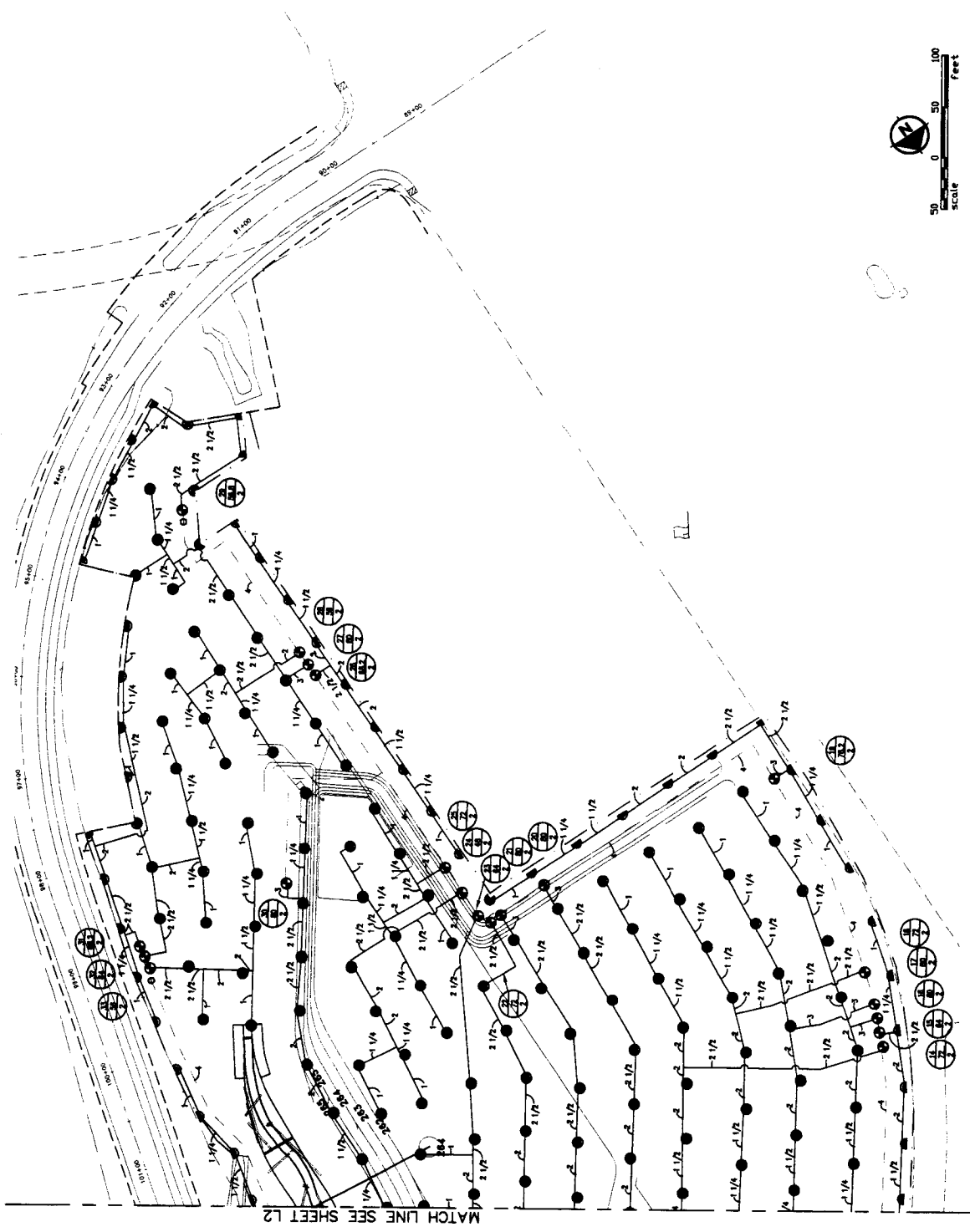
| ELEVATIONS | DATE     |
|------------|----------|
| 1          | 12/12/12 |
| 2          | 12/12/12 |
| 3          | 12/12/12 |
| 4          | 12/12/12 |
| 5          | 12/12/12 |
| 6          | 12/12/12 |
| 7          | 12/12/12 |
| 8          | 12/12/12 |
| 9          | 12/12/12 |
| 10         | 12/12/12 |

|              |                               |
|--------------|-------------------------------|
| CONTRACT NO. | 1000                          |
| PROJECT NO.  | 29121712                      |
| DATE         | 12/12/12                      |
| SCALE        | AS SHOWN                      |
| PROJECT      | SEA-TAC INTERNATIONAL AIRPORT |
| CONTRACTOR   | PARAMETRIX, INC.              |

CALL 48 HOURS BEFORE YOU INC 1-800-424-5555

DATE: 11/29/12 PLANE: 291712 SHEET: 13 OF 13  
 CONTRACTOR: Parametrix, Inc.

AR 049431



AGENCY REVIEW  
NOT FOR CONSTRUCTION

**Portland**  
SEA-TAC INTERNATIONAL AIRPORT  
MILLER CREEK RELOCATION  
IRRIGATION PLAN S

PROJECT NO. 281217L3  
SHEET NO. 13

DATE: 11/13/01  
DRAWN: 201713

SCALE: 1" = 100'

DESIGNER: Parametrix, Inc.

CALL US NOW!  
FOR A FREE  
ESTIMATE  
1-800-421-3825

WE ARE THE  
LEADER IN  
IRRIGATION  
DESIGN

WE CAN HELP YOU  
WITH YOUR  
IRRIGATION  
DESIGN

WE CAN HELP YOU  
WITH YOUR  
IRRIGATION  
DESIGN

WE CAN HELP YOU  
WITH YOUR  
IRRIGATION  
DESIGN

WE CAN HELP YOU  
WITH YOUR  
IRRIGATION  
DESIGN

WE CAN HELP YOU  
WITH YOUR  
IRRIGATION  
DESIGN

WE CAN HELP YOU  
WITH YOUR  
IRRIGATION  
DESIGN

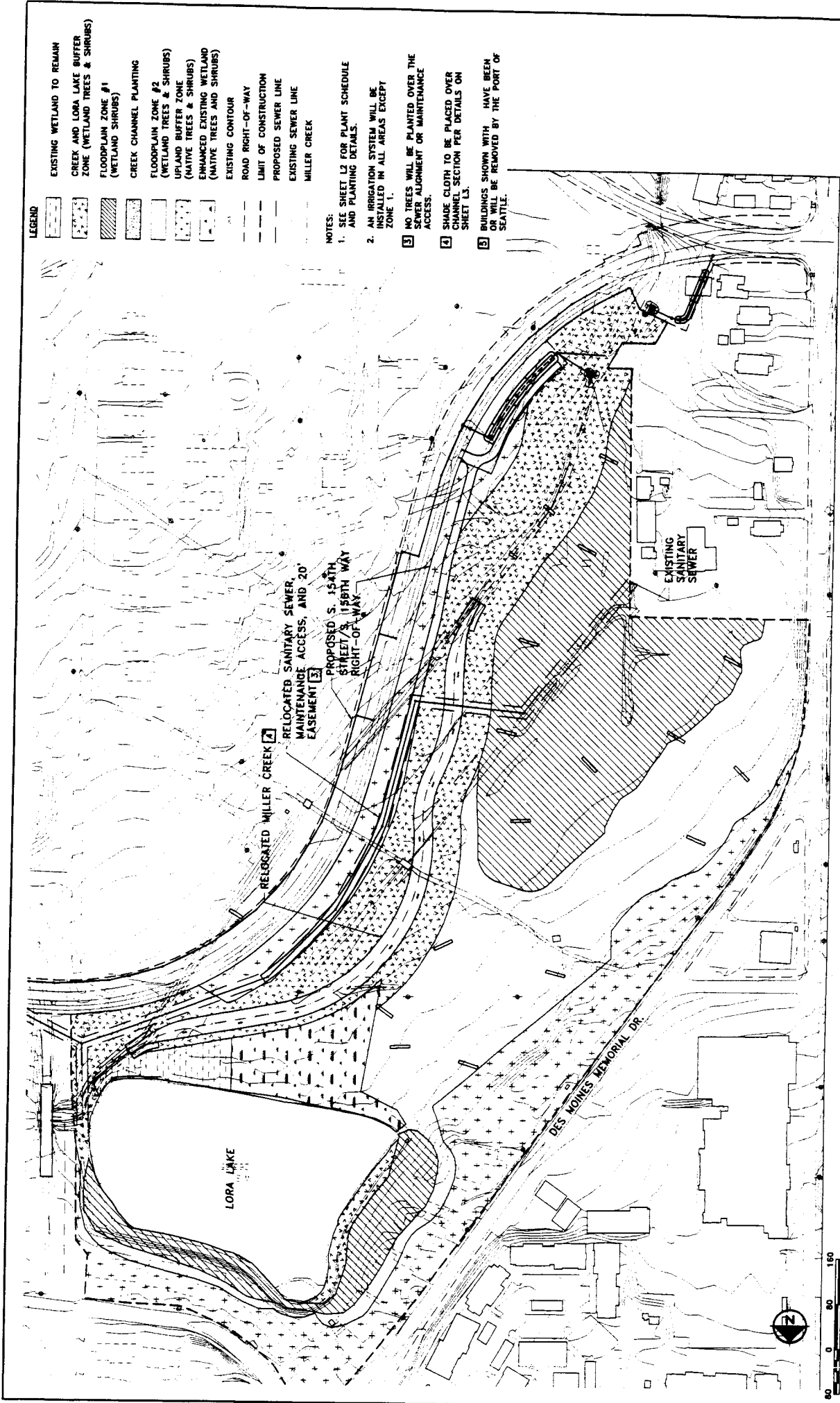
WE CAN HELP YOU  
WITH YOUR  
IRRIGATION  
DESIGN

WE CAN HELP YOU  
WITH YOUR  
IRRIGATION  
DESIGN

WE CAN HELP YOU  
WITH YOUR  
IRRIGATION  
DESIGN

WE CAN HELP YOU  
WITH YOUR  
IRRIGATION  
DESIGN

AR 049432



**AGENCY REVIEW**  
**NOT FOR CONSTRUCTION**

**Port of Seattle**  
**SEA-TAC INTERNATIONAL AIRPORT**  
 MILLER CREEK RELOCATION  
 PROJECT NO. 281217/L4  
 SHEET NO. PLANTING PLAN

|      |             |
|------|-------------|
| DATE | DESCRIPTION |
|      |             |
|      |             |

|      |             |
|------|-------------|
| DATE | DESCRIPTION |
|      |             |
|      |             |

|      |             |
|------|-------------|
| DATE | DESCRIPTION |
|      |             |
|      |             |

|      |             |
|------|-------------|
| DATE | DESCRIPTION |
|      |             |
|      |             |

|      |             |
|------|-------------|
| DATE | DESCRIPTION |
|      |             |
|      |             |

|      |             |
|------|-------------|
| DATE | DESCRIPTION |
|      |             |
|      |             |

|      |             |
|------|-------------|
| DATE | DESCRIPTION |
|      |             |
|      |             |

|      |             |
|------|-------------|
| DATE | DESCRIPTION |
|      |             |
|      |             |

|      |             |
|------|-------------|
| DATE | DESCRIPTION |
|      |             |
|      |             |

|      |             |
|------|-------------|
| DATE | DESCRIPTION |
|      |             |
|      |             |

|      |             |
|------|-------------|
| DATE | DESCRIPTION |
|      |             |
|      |             |

|      |             |
|------|-------------|
| DATE | DESCRIPTION |
|      |             |
|      |             |

|      |             |
|------|-------------|
| DATE | DESCRIPTION |
|      |             |
|      |             |

|      |             |
|------|-------------|
| DATE | DESCRIPTION |
|      |             |
|      |             |

|      |             |
|------|-------------|
| DATE | DESCRIPTION |
|      |             |
|      |             |

|      |             |
|------|-------------|
| DATE | DESCRIPTION |
|      |             |
|      |             |

|      |             |
|------|-------------|
| DATE | DESCRIPTION |
|      |             |
|      |             |

|      |             |
|------|-------------|
| DATE | DESCRIPTION |
|      |             |
|      |             |

158.DWG

AR 049433

DATE 11/13/01 FILENAME 281217/L4 SHEET 158 OF 158

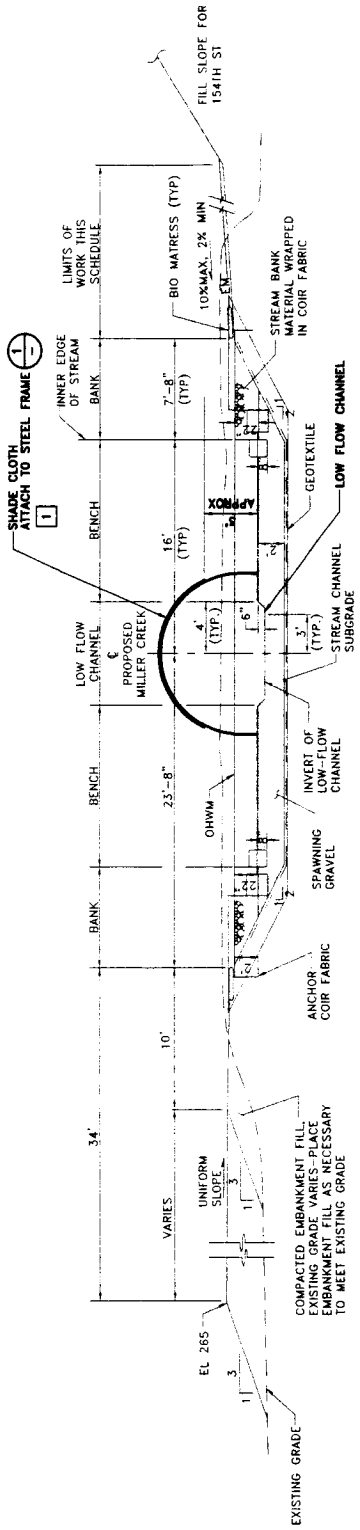
CALL 40 HOURS BEFORE YOU DIG 1-800-424-5555

**Parametrix, Inc.**  
 5808 Lt. Washington Blvd. NE  
 Kirkland, WA 98033  
 Ph: (425) 822-8800

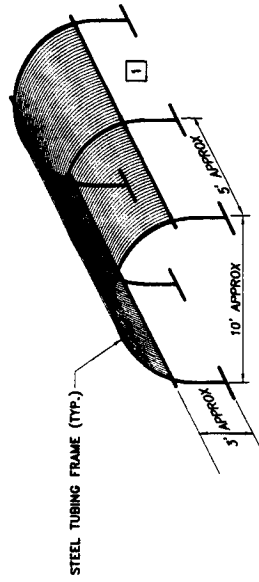
281217/L4.DWG

APPENDIX A





**SECTION**  
SHADECLOTH  
SCALE 1/25



**DETAIL**  
SHADECLOTH  
NTS

AGENCY REVIEW  
NOT FOR CONSTRUCTION

Part of Seattle  
SEA-TAC INTERNATIONAL AIRPORT  
MILLER CREEK RELOCATION  
PROJECT NO. 02-0000-16  
SHEET NO. 02-0000-16

|             |          |
|-------------|----------|
| DATE        | 10/08/11 |
| DESIGNED BY | ...      |
| CHECKED BY  | ...      |
| DATE        | 2/12/15  |
| DESIGNED BY | ...      |
| CHECKED BY  | ...      |

| NO. | DATE | BY | REVISION |
|-----|------|----|----------|
|     |      |    |          |
|     |      |    |          |
|     |      |    |          |
|     |      |    |          |
|     |      |    |          |



**Paramatrix, Inc.**  
5908 Lt. Washington Blvd. NE  
Redmond, WA 98053  
PH: (425) 822-8880  
Quality Service Through Employee Ownership

CALL 48 HOURS  
BEFORE FOR THE  
1-800-427-0885

DATE: 11/15/07 P/NAME: 291217L6  
PAGE: 3

APPENDIX A

AR 049435



Port of Seattle

Aviation Division

# APPENDIX B

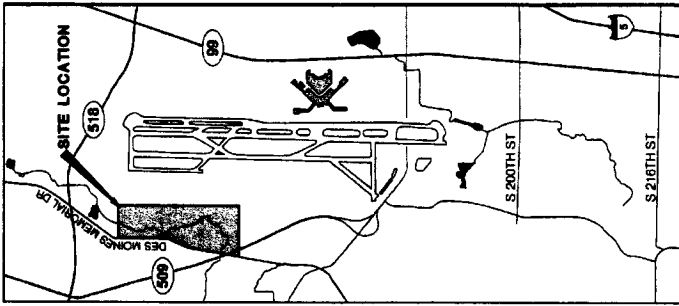
# MILLER CREEK INSTREAM AND BUFFER ENHANCEMENTS FOR SEATTLE-TACOMA INTERNATIONAL AIRPORT

AGENCY REVIEW  
NOT FOR CONSTRUCTION

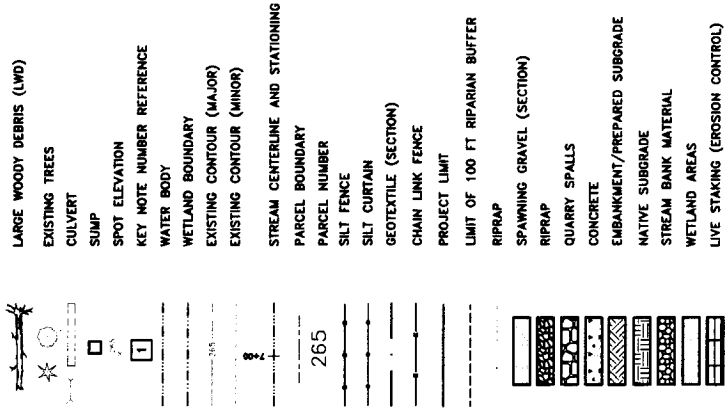
| SHEET NO.   | TITLE SHEET                                        | SHEET TITLE | SHEET NO.   | SHEET TITLE                                         | SHEET NO.    | SHEET TITLE                                         | MAJOR CONTRACT           |
|-------------|----------------------------------------------------|-------------|-------------|-----------------------------------------------------|--------------|-----------------------------------------------------|--------------------------|
| STA-8808-11 | TITLE SHEET                                        |             | STA-8808-11 | LANDSCAPE INDEX                                     | STA-8808-117 | EXISTING CONDITIONS AND WETLAND ENHANCEMENT ACTIONS |                          |
| STA-8808-12 | NEIGHBORHOOD MAP, SYMBOLS, NOTES AND ABBREVIATIONS |             | STA-8808-12 | LANDSCAPE PLAN                                      | STA-8808-118 | EXISTING CONDITIONS AND WETLAND ENHANCEMENT ACTIONS |                          |
| STA-8808-13 | PROJECT PLAN                                       |             | STA-8808-13 | LANDSCAPE PLAN                                      |              |                                                     | RECOMMENDED FOR APPROVAL |
| STA-8808-14 | INSTREAM PROJECT AREA 1 PLAN                       |             | STA-8808-14 | LANDSCAPE PLAN                                      |              |                                                     | DATE                     |
| STA-8808-15 | INSTREAM PROJECT AREA 2 PLAN                       |             | STA-8808-15 | LANDSCAPE PLAN                                      |              |                                                     | DATE                     |
| STA-8808-16 | INSTREAM PROJECT AREA 3 PLAN                       |             | STA-8808-16 | LANDSCAPE PLAN                                      |              |                                                     | DATE                     |
| STA-8808-17 | INSTREAM PROJECT AREA 4 PLAN                       |             | STA-8808-17 | LANDSCAPE PLAN                                      |              |                                                     | DATE                     |
| STA-8808-18 | INSTREAM LVO PLACEMENT PLAN                        |             | STA-8808-18 | LANDSCAPE PLAN                                      |              |                                                     | DATE                     |
| STA-8808-19 | INSTREAM SECTIONS AND PROFILE                      |             | STA-8808-19 | LANDSCAPE PLAN                                      |              |                                                     | DATE                     |
| STA-8808-20 | INSTREAM DETAILS                                   |             | STA-8808-20 | IRRIGATION PLAN                                     |              |                                                     | APPROVED BY              |
| STA-8808-21 | STREAM BUFFER AND ENHANCEMENT CROSS-SECTION        |             | STA-8808-21 | PLANTING SCHEDULE AND DETAILS                       |              |                                                     |                          |
| STA-8808-22 | SITE GRADING                                       |             | STA-8808-22 | GRAVING AT 5' 15TH WALK BRIDGE                      |              |                                                     |                          |
| STA-8808-23 | SITE GRADING                                       |             | STA-8808-23 | BRIDGE REMOVAL AND TEMPORARY EROSION CONTROL PLAN   |              |                                                     |                          |
| STA-8808-24 | TESC PLAN - PROJECT AREA 1                         |             | STA-8808-24 | EXISTING CONDITIONS AND WETLAND ENHANCEMENT ACTIONS |              |                                                     |                          |
| STA-8808-25 | TESC PLAN - PROJECT AREA 2                         |             | STA-8808-25 | EXISTING CONDITIONS AND WETLAND ENHANCEMENT ACTIONS |              |                                                     |                          |
| STA-8808-26 | TESC PLAN - PROJECT AREA 3                         |             | STA-8808-26 | EXISTING CONDITIONS AND WETLAND ENHANCEMENT ACTIONS |              |                                                     |                          |
| STA-8808-27 | TESC PLAN - PROJECT AREA 4                         |             | STA-8808-27 | EXISTING CONDITIONS AND WETLAND ENHANCEMENT ACTIONS |              |                                                     |                          |
| STA-8808-28 | TESC DETAILS                                       |             | STA-8808-28 | EXISTING CONDITIONS AND WETLAND ENHANCEMENT ACTIONS |              |                                                     |                          |
| STA-8808-29 | TESC DETAILS                                       |             | STA-8808-29 | EXISTING CONDITIONS AND WETLAND ENHANCEMENT ACTIONS |              |                                                     |                          |



**VICINITY MAP**



**LEGEND**



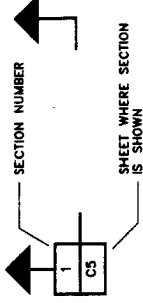
**GENERAL LEGEND**

**DRAWING TITLE:**

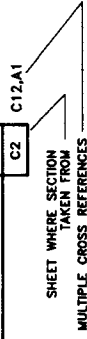


**PLAN**  
SUBTITLE  
SUBTITLE  
SCALE

**REFERENCE SYMBOL:**



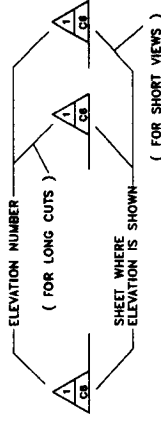
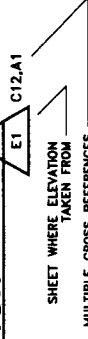
**SECTION**  
SUBTITLE  
SUBTITLE  
SCALE



**DETAIL**  
SUBTITLE  
SUBTITLE  
SCALE



**ELEVATION**  
SUBTITLE  
SUBTITLE  
SCALE



**GENERAL ABBREVIATIONS**

|             |                       |           |                        |
|-------------|-----------------------|-----------|------------------------|
| APPROX      | APPROXIMATE           | NTS       | NOT TO SCALE           |
| CB          | CATCH BASIN           | NIC       | NOT IN CONTRACT        |
| C.L. OR C   | CENTERLINE            | OC        | ON CENTER              |
| CON         | CONCRETE              | POS       | PORT OF SEATTLE        |
| CONST       | CONSTRUCTION          | RECD      | REQUIRED CONCRETE PIPE |
| CMP         | CORRUGATED METAL PIPE | R/W       | RIGHT OF WAY           |
| DIA         | DIAMETER              | SCH       | SCHEDULE               |
| E           | EAST/EASTING          | SD        | STORM DRAIN            |
| EL OR ELEV  | ELEVATION             | SPEC      | SPECIFICATION(S)       |
| EL OR EXIST | ELEVATION EXISTING    | SQ        | SQUARE FOOT/FEET       |
| F           | FOOT/FEET             | SS        | SANITARY SEWER         |
| G           | GALLON                | SS        | SQUARE YARD/YARDS      |
| GA          | GAL                   | ST        | STATION                |
| GAL         | GALLON                | ST        | STREET                 |
| GR          | GRADE                 | STD       | STANDARD               |
| HT          | HEIGHT                | TRIP      | TRIP                   |
| HORIZ OR H  | HORIZONTAL            | TYP       | TYPICAL                |
| IE          | INVERT ELEVATION      | VERT OR V | VERTICAL               |
| INT         | INTERSECTION          | W/        | WITH                   |
| MAX         | MAXIMUM               | WS        | WATER SURFACE          |
| MIN         | MINIMUM               | YR        | YEAR                   |
| MISC        | MISCELLANEOUS         |           |                        |
| N           | NORTH/NORTHING        |           |                        |

**GENERAL NOTES**

1. WETLAND AND OTHER VEGETATION NOT TO BE DISTURBED WILL BE DELINEATED AND FENCED BY THE ENGINEER.
2. HAZARDOUS MATERIALS AND SOILS WILL BE DISPOSED OFF SITE IN A PRE-APPROVED LOCATION.

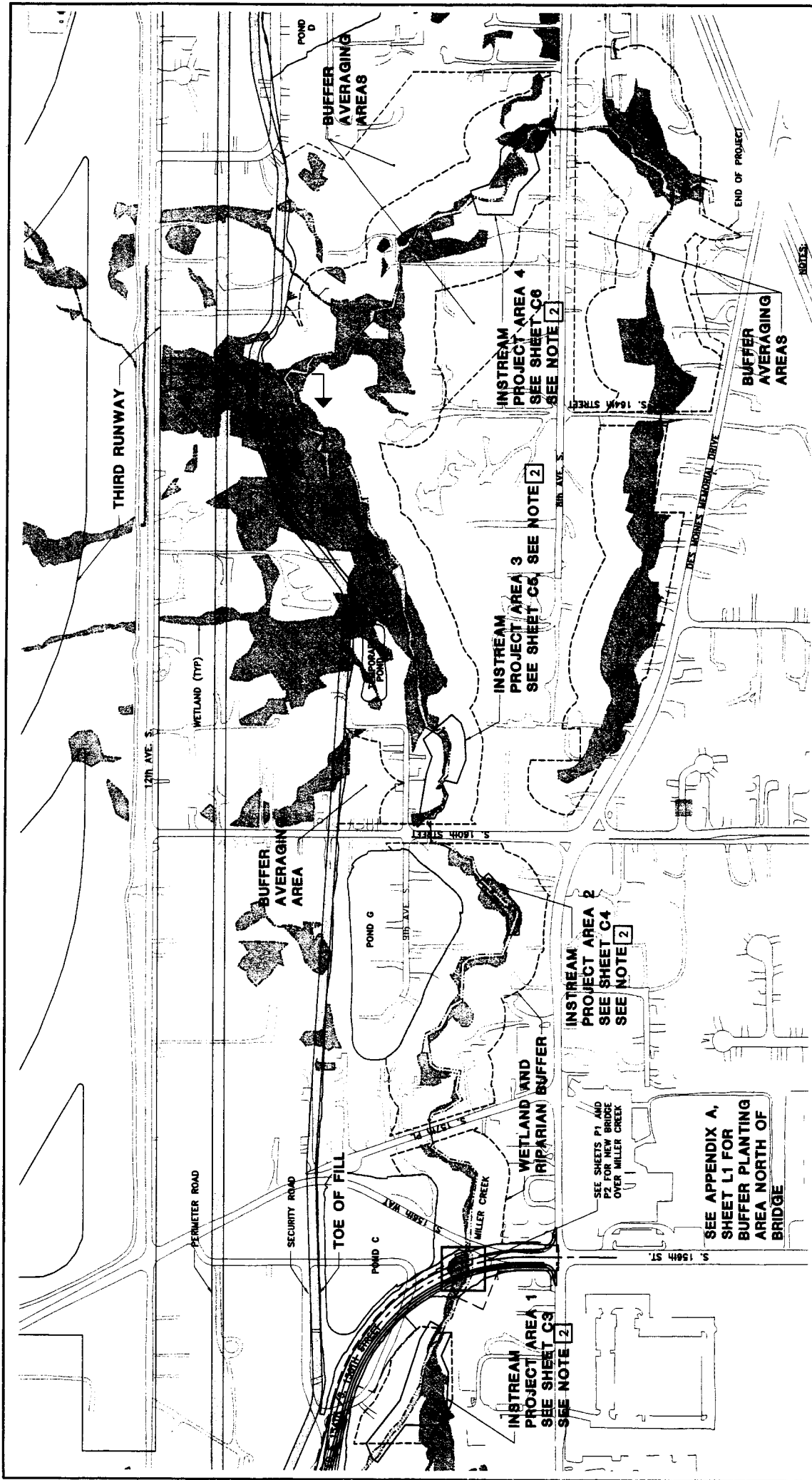
**GENERAL TEMPORARY EROSION AND SEDIMENTATION CONTROL (TESC) NOTES**

1. TESC BMPs SHALL BE INSTALLED BY CONTRACTOR AND APPROVED BY THE ENGINEER PRIOR TO ANY EARTHWORK.
2. ALL DISTURBED AREAS SHALL BE COVERED IMMEDIATELY WHEN UNWORKED. ALL DISTURBED AREAS COMPLETED OR TO REMAIN UNWORKED FOR MORE THAN 15 DAYS SHALL BE SEEDED WITHIN 7 DAYS.
3. BIODEGRADABLE COIR FABRIC MATTING SHALL BE PLACED OVER DISTURBED SLOPES (EXCEPT IN AREAS WHERE COIR FABRIC LIFTS ARE IN PLACE). GEOTEXTILE FABRIC SHALL BE PLACED AFTER SEEDING.
4. CONSTRUCTION ACTIVITY OCCURRING WITHIN THE ORDINARY HIGH WATER MARK SHALL BE CONDUCTED DURING SUMMER BASE FLOW CONDITIONS AND WITH NO PRECIPITATION FORECAST WITHIN 48 HOURS. ALL ACTIVITIES WITHIN ORDINARY HIGH WATER MARK SHALL BE STAGED SUCH THAT DISTURBED AREAS ARE STABILIZED WITHIN 24 HOURS. ALL EQUIPMENT WILL OPERATE OUTSIDE THE ORDINARY HIGH WATERMARK.

**AGENCY REVIEW**

|                                                       |  |                                                                                                                                                     |  |                                                                                             |  |                                                                                                                                                                              |  |                                                                                         |  |
|-------------------------------------------------------|--|-----------------------------------------------------------------------------------------------------------------------------------------------------|--|---------------------------------------------------------------------------------------------|--|------------------------------------------------------------------------------------------------------------------------------------------------------------------------------|--|-----------------------------------------------------------------------------------------|--|
| <b>Call 48 Hours Before You Dig</b><br>1-800-424-5555 |  | <b>Parametrix, Inc.</b><br>5808 1st Washington Blvd. NE<br>Kirkland, WA 98033<br>Ph: (425) 822-8890<br>"Quality Service Through Employee Ownership" |  | <b>DESIGNED BY</b><br>J. MANTOZZI, LICENSED<br>P.E. 21725<br>AS 3/20/20<br>DATE: 10/27/2021 |  | <b>PROJECT NUMBER</b><br>SEA-TAC INTERNATIONAL AIRPORT<br>MULLER CREEK INSTREAM AND BUFFER ENHANCEMENTS<br>VICINITY MAP, SYMBOLS, NOTES<br>AND ABBREVIATIONS<br>SHEET NO. 05 |  | <b>DATE</b><br>21/28/21<br><b>PROJECT NUMBER</b><br>STA-8808-C1<br><b>APPENDIX</b><br>B |  |
|-------------------------------------------------------|--|-----------------------------------------------------------------------------------------------------------------------------------------------------|--|---------------------------------------------------------------------------------------------|--|------------------------------------------------------------------------------------------------------------------------------------------------------------------------------|--|-----------------------------------------------------------------------------------------|--|

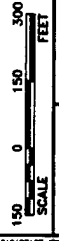
DATE: 11/19/21 REV: 1  
METS: Venti/Map/Appendix



NOTES:

1. ACCESS TO PROJECT SITES BY APPROVAL OF ENGINEER.
2. PROJECT AREAS INCLUDE ADDITIONAL BRIDGE REMOVAL AND LWD INSTALLATION (SEE SHEETS C7 AND C10)

**AGENCY REVIEW  
NOT FOR CONSTRUCTION**



CALL US NOW!  
 CALL US TODAY!  
 1-800-424-8335

**Parametrix, Inc.**  
 9808 L.L. Washington Blvd. NE  
 Redmond, WA 98073  
 PH: (425) 822-8800

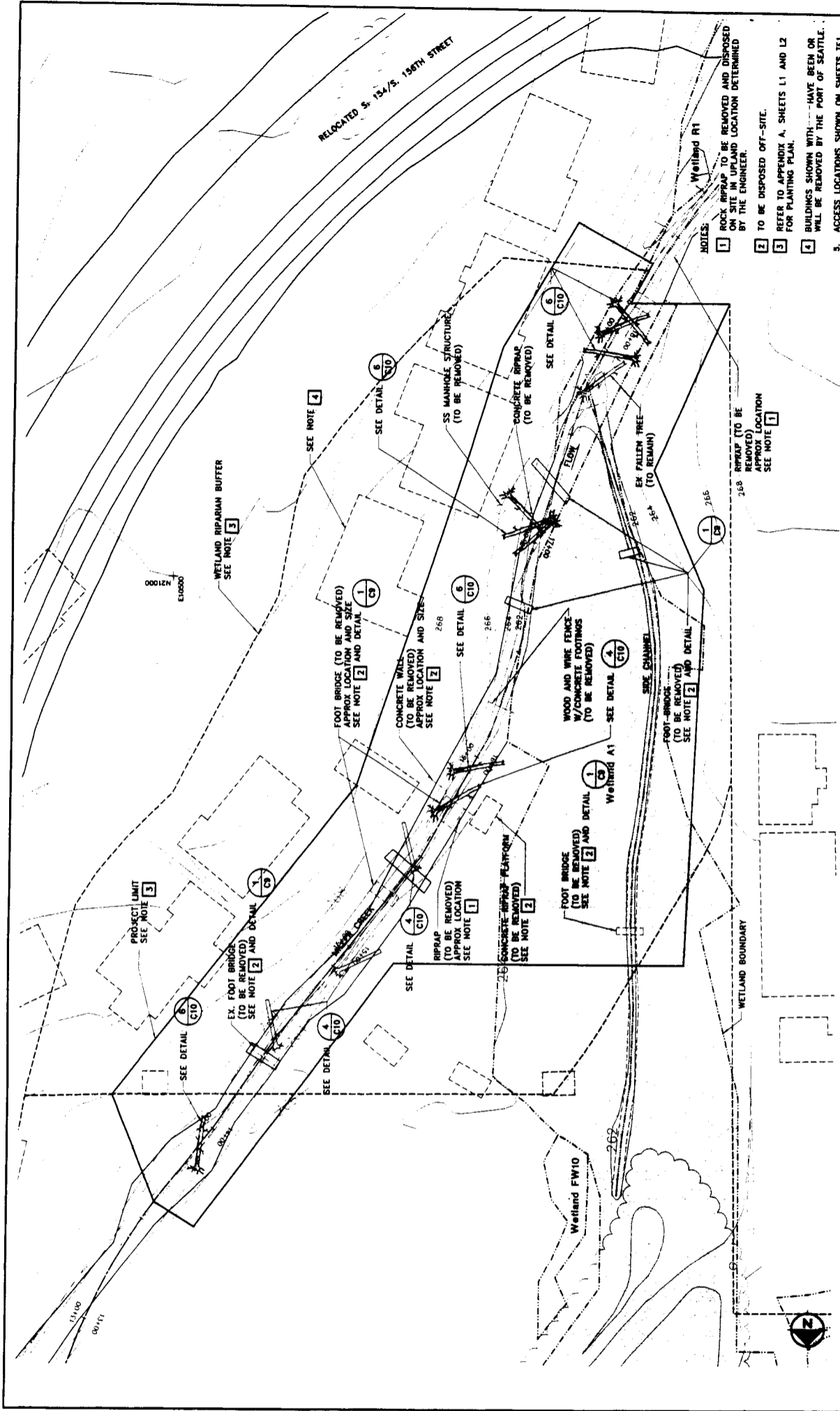
PROJECT NO. 2812815K  
 SHEET NO. 2812815K-001

| REVISIONS |             |
|-----------|-------------|
| NO.       | DESCRIPTION |
|           |             |
|           |             |
|           |             |
|           |             |
|           |             |
|           |             |
|           |             |
|           |             |
|           |             |

Part of Seattle  
**SEA-TAC INTERNATIONAL AIRPORT**  
 MILLER CREEK INSTREAM AND BUFFER ENHANCEMENT  
**PROJECT PLAN**

DATE: 11/27/07  
 DRAWN: 2812815K  
 CHECKED: 2812815K  
 TITLE: 2812815K-001  
 PROJECT NO.: 2812815K  
 SHEET NO.: 2812815K-001  
 STA: 8006-C2  
 APPENDIX B

AR 049438



SCALE 0 20 40 FEET  
 CALL US NOW  
 BEFORE YOU GO  
 1-800-424-5555  
**Parametrix, Inc.**  
 5808 U. Washington Blvd. HE  
 Kent, WA 98032  
 Ph: (425) 872-8000  
 Fax: (425) 872-8001  
 "Quality Service Through Employee Ownership"  
 C. ODETT

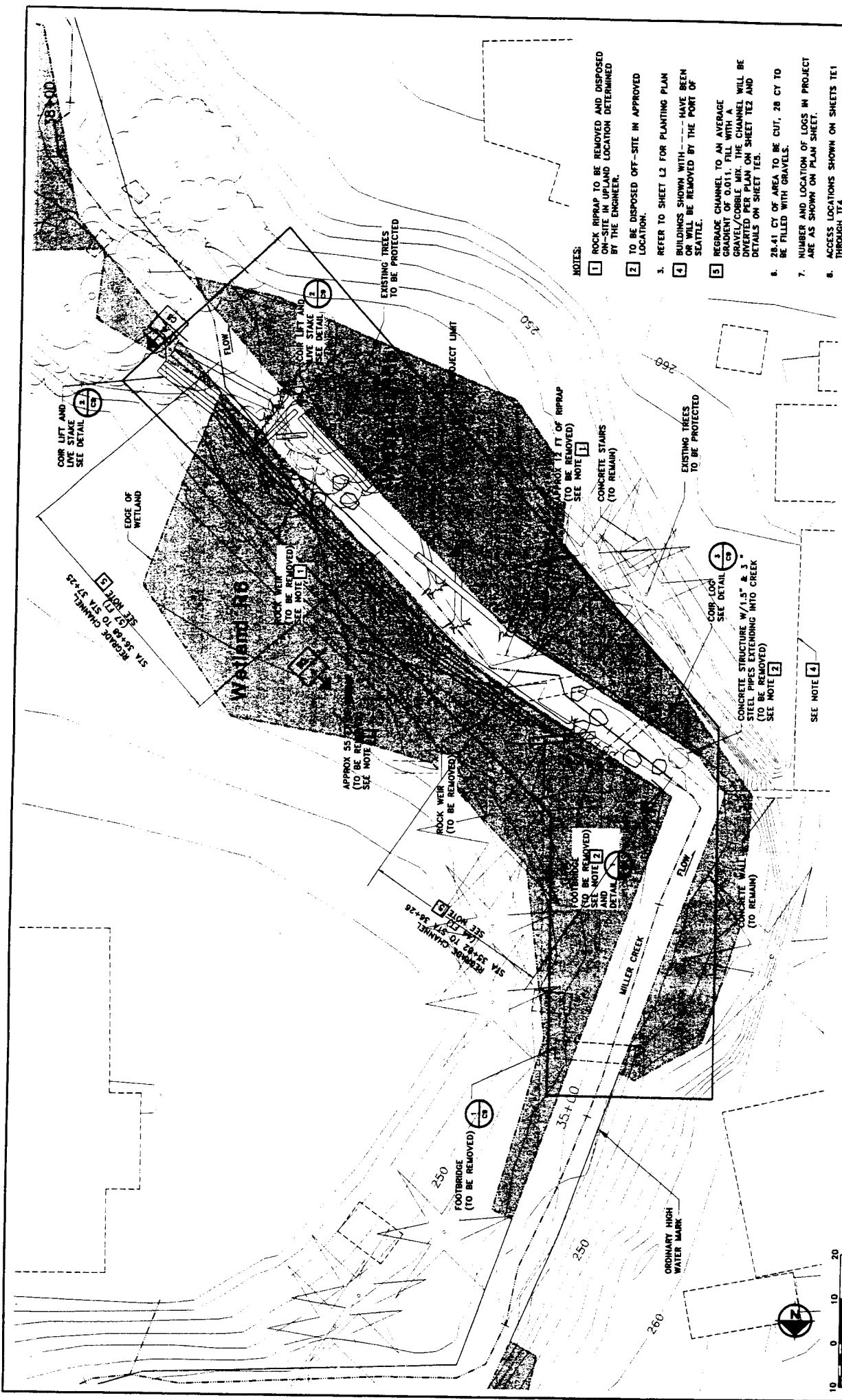
DATE: 11/20/98 PLAN: 291201C  
 SHEETS: 291201A, 291201B, 291201C, 291201D, 291201E, 291201F, 291201G, 291201H, 291201I, 291201J, 291201K, 291201L, 291201M, 291201N, 291201O, 291201P, 291201Q, 291201R, 291201S, 291201T, 291201U, 291201V, 291201W, 291201X, 291201Y, 291201Z  
 291201M, 291201N, 291201O, 291201P, 291201Q, 291201R, 291201S, 291201T, 291201U, 291201V, 291201W, 291201X, 291201Y, 291201Z

**NOT FOR CONSTRUCTION**  
**AGENCY REVIEW**  
 Access locations shown on sheets T-1 through T-4.  
 Buildings shown with --- have been or will be removed by the Port of Seattle.  
 2. TO BE DISPOSED OFF-SITE.  
 3. REFER TO APPENDIX A, SHEETS L1 AND L2 FOR PLANTING PLAN.  
 4. ACCESS LOCATIONS SHOWN ON SHEETS T-1 THROUGH T-4.  
 5.

**NOTES:**  
 1. ROCK RIPRAP TO BE REMOVED AND DISPOSED ON SITE IN UPLAND LOCATION DETERMINED BY THE ENGINEER.  
 2. TO BE DISPOSED OFF-SITE.  
 3. REFER TO APPENDIX A, SHEETS L1 AND L2 FOR PLANTING PLAN.  
 4. BUILDINGS SHOWN WITH --- HAVE BEEN OR WILL BE REMOVED BY THE PORT OF SEATTLE.  
 5. ACCESS LOCATIONS SHOWN ON SHEETS T-1 THROUGH T-4.

**SEA-TAC INTERNATIONAL AIRPORT**  
**MILLER CREEK INSTREAM AND BUFFER ENHANCEMENTS**  
**INSTREAM PROJECT AREA 1 PLAN**  
 291201C  
 STA-1000-C3  
 APPENDIX B

AR 049439



- NOTES:**
1. ROCK RIPRAP TO BE REMOVED AND DISPOSED ON-SITE IN UPLAND LOCATION DETERMINED BY THE ENGINEER.
  2. TO BE DISPOSED OFF-SITE IN APPROVED LOCATION.
  3. REFER TO SHEET L2 FOR PLANTING PLAN
  4. BUILDINGS SHOWN WITH --- HAVE BEEN OR WILL BE REMOVED BY THE PORT OF SEATTLE.
  5. REGRADE CHANNEL TO AN AVERAGE GRADIENT OF 0.011. FILL WITH A GRAVEL/CORBLE MIX. THE CHANNEL WILL BE REDEFINED ON PLAN ON SHEET TE2 AND DETAILS ON SHEET TE3.
  6. 28.41 CY OF AREA TO BE CUT, 28 CY TO BE FILLED WITH GRAVELS.
  7. NUMBER AND LOCATION OF LOSSES IN PROJECT ARE AS SHOWN ON PLAN SHEET.
  8. ACCESS LOCATIONS SHOWN ON SHEETS TE1 THROUGH TE4.

**NOT FOR CONSTRUCTION**  
**AGENCY REVIEW**

**Port of Seattle**  
**SEA-TAC INTERNATIONAL AIRPORT**  
 MILLER CREEK INSTREAM AND BUFFER ENHANCEMENTS  
 PROJECT NO. 291281C5  
 SHEET NO. 291281C5-04  
 STA-3000-C4

|             |             |
|-------------|-------------|
| DATE        | 291201WL    |
| SCALE       | AS SHOWN    |
| PROJECT NO. | 291281C5    |
| SHEET NO.   | 291281C5-04 |
| STA         | 3000-C4     |

|     |      |    |             |
|-----|------|----|-------------|
| NO. | DATE | BY | DESCRIPTION |
|     |      |    |             |
|     |      |    |             |
|     |      |    |             |
|     |      |    |             |

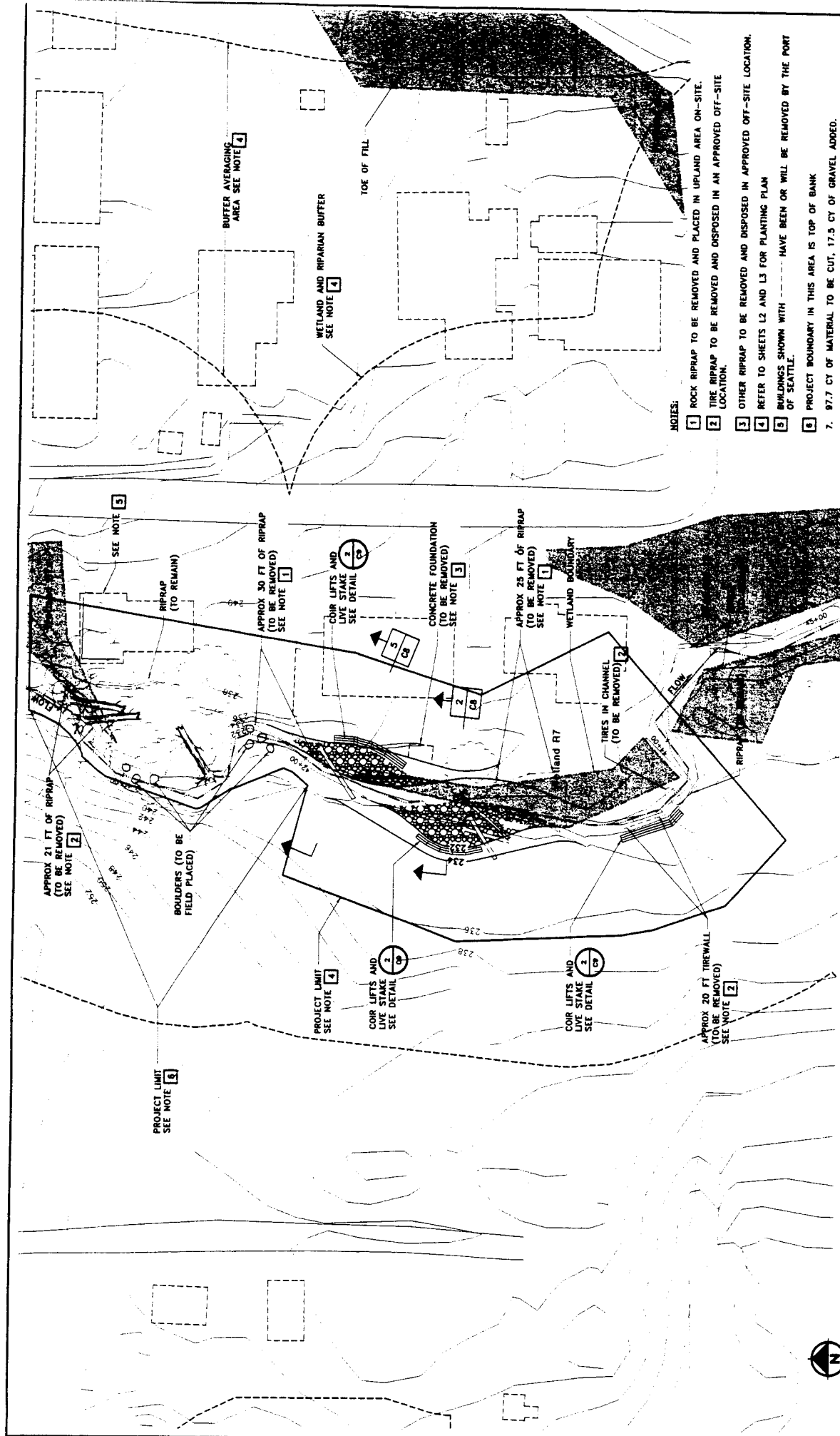
|             |             |
|-------------|-------------|
| DATE        | 291201WL    |
| SCALE       | AS SHOWN    |
| PROJECT NO. | 291281C5    |
| SHEET NO.   | 291281C5-04 |
| STA         | 3000-C4     |

|             |             |
|-------------|-------------|
| DATE        | 291201WL    |
| SCALE       | AS SHOWN    |
| PROJECT NO. | 291281C5    |
| SHEET NO.   | 291281C5-04 |
| STA         | 3000-C4     |

**Parametrix, Inc.**  
 3000 Lt. Washington Blvd. NE  
 Bellevue, WA 98005  
 PH (425) 882-8800  
 Fax (206) 882-8801  
 Quality Service Through Employee Ownership  
 P. 072007

DATE: 11/1/07  
 PLANS: 291281C5  
 SHEET: 291281C5-04  
 APPENDIX B

AR 049440



- NOTES:**
- 1 ROCK RIPRAP TO BE REMOVED AND PLACED IN UPLAND AREA ON-SITE.
  - 2 TIRE RIPRAP TO BE REMOVED AND DISPOSED IN AN APPROVED OFF-SITE LOCATION.
  - 3 OTHER RIPRAP TO BE REMOVED AND DISPOSED IN APPROVED OFF-SITE LOCATION.
  - 4 REFER TO SHEETS L2 AND L3 FOR PLANTING PLAN
  - 5 BUILDINGS SHOWN WITH ----- HAVE BEEN OR WILL BE REMOVED BY THE PORT OF SEATTLE.
  - 6 PROJECT BOUNDARY IN THIS AREA IS TOP OF BANK
  7. 97.7 CY OF MATERIAL TO BE CUT, 17.9 CY OF GRAVEL ADDED.
  8. NUMBER AND LOCATION OF LOGS IN PROJECT ARE AS SHOWN ON PLAN SHEET.
  9. ACCESS LOCATIONS SHOWN ON SHEETS TE1 THROUGH TE4.

SCALE 0 20 40 FEET

CALL 48 HOURS BEFORE YOU DIG 1-800-424-5555

**Parametrix, Inc.**  
 5600 1st Washington Blvd. NE  
 Bellevue, WA 98003  
 Ph: (425) 852-8800  
 Quality Service Through Employee Ownership®

**PROJECT INFORMATION**

| NO. | DATE | DESCRIPTION |
|-----|------|-------------|
|     |      |             |
|     |      |             |
|     |      |             |
|     |      |             |

**REVISIONS**

| NO. | DATE | DESCRIPTION |
|-----|------|-------------|
|     |      |             |
|     |      |             |
|     |      |             |
|     |      |             |

**PROJECT INFORMATION**

|              |                                                                             |
|--------------|-----------------------------------------------------------------------------|
| PROJECT NO.  | 291201WA2                                                                   |
| PROJECT NAME | SEATTLE INTERNATIONAL AIRPORT MILLER CREEK INSTREAM AND BUFFER ENHANCEMENTS |
| SHEET NO.    | INSTREAM PROJECT AREA 3 PLAN                                                |
| DATE         | 11/13/01                                                                    |
| PLANNED BY   | 291201WA                                                                    |
| DRAWN BY     | 291201WA                                                                    |
| CHECKED BY   | 291201WA                                                                    |
| APPROVED BY  | 291201WA                                                                    |

**NOT FOR CONSTRUCTION**

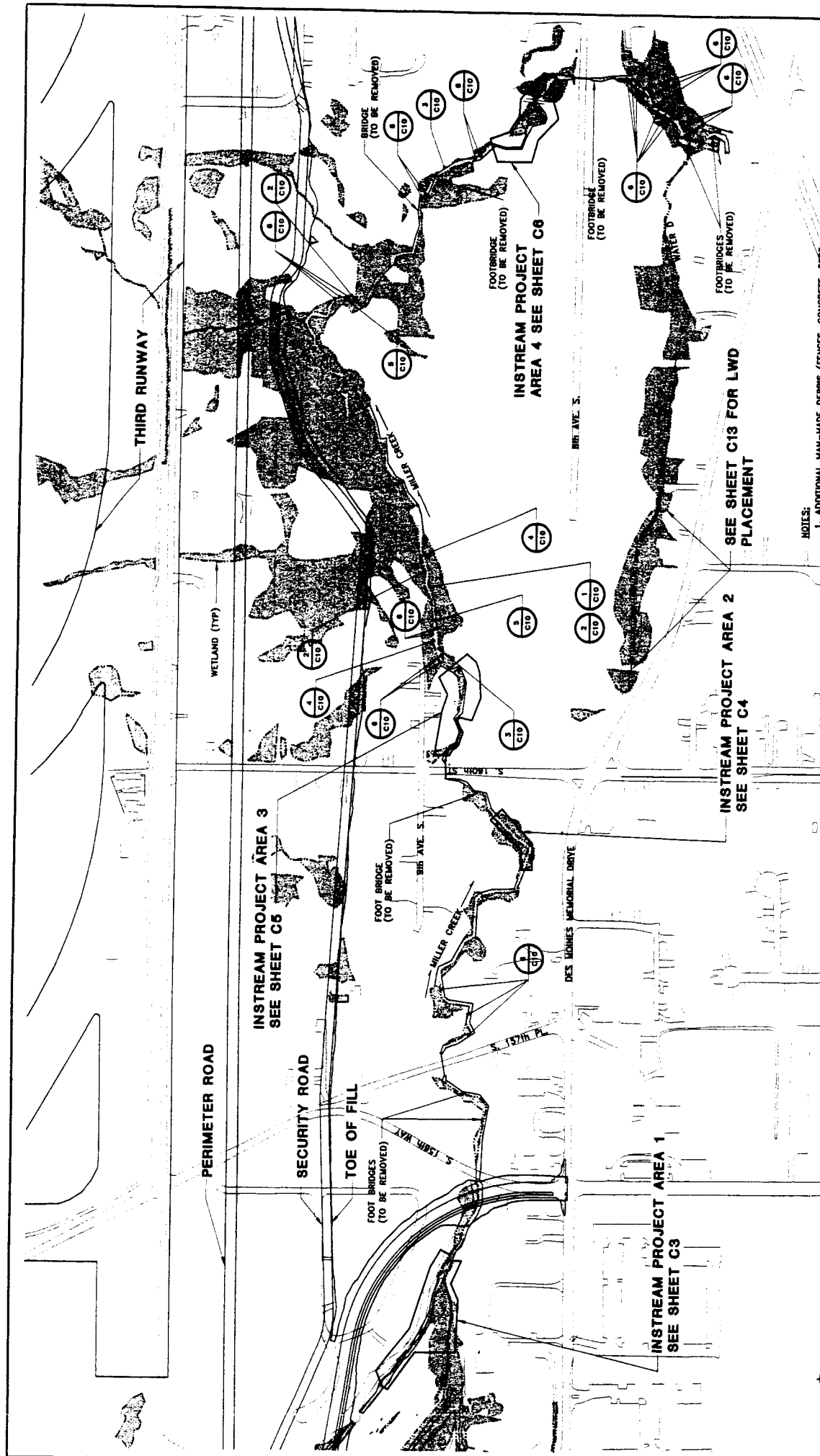
Port of Seattle  
 SEATTLE INTERNATIONAL AIRPORT  
 MILLER CREEK INSTREAM AND BUFFER ENHANCEMENTS  
 SHEET NO. INSTREAM PROJECT AREA 3 PLAN

DATE: 11/13/01 PLANNED BY: 291201WA DRAWN BY: 291201WA CHECKED BY: 291201WA APPROVED BY: 291201WA

291201WA2 291201WA 291201WA

AR 049441





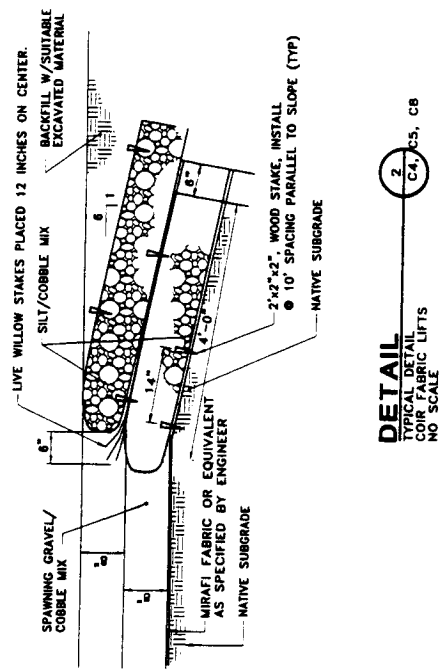
**NOTES:**  
 1. ADDITIONAL MAN-MADE DEBRIS (FENCES, CONCRETE, FOOT BRIDGES) WILL BE REMOVED FROM THE STREAM REACH AND DISPOSED OFF-SITE IN AN APPROVED LOCATION.  
 2. ACCESS LOCATIONS SHOWN ON SHEETS T-E1 THROUGH T-E4.

|                                                                                                                                                                                 |                                                                                                                                                   |
|---------------------------------------------------------------------------------------------------------------------------------------------------------------------------------|---------------------------------------------------------------------------------------------------------------------------------------------------|
| <b>AGENCY REVIEW</b><br><b>NOT FOR CONSTRUCTION</b>                                                                                                                             |                                                                                                                                                   |
| <b>Part of Seattle</b><br><b>SEA-TAC INTERNATIONAL AIRPORT</b><br><b>MILLER CREEK INSTREAM BUFFER ENHANCEMENT</b><br><b>PROJECT NO. 281201C15</b><br><b>SHEET NO. 281201C15</b> | <b>INSTREAM LWD PLACEMENT</b>                                                                                                                     |
| SCALE: 0 150 300 FEET<br>CALL US 24 HOURS BEFORE YOU DIG: 1-800-474-5355                                                                                                        | <b>Parametrix, Inc.</b><br>3408 1st Washington Blvd, NE<br>Kirkland, WA 98033<br>PH: (425) 822-8900<br>Quality Service Through Employee Ownership |
| DATE: 11/27/01<br>DRAWN: 281201C15<br>CHECKED: 281201C15<br>PROJECT NO.: 281201C15<br>SHEET NO.: 281201C15                                                                      | 281201C15<br>281201C15<br>281201C15<br>281201C15                                                                                                  |
| 281201B42<br>281201C15<br>281201C15<br>281201C15                                                                                                                                | 281201C15<br>281201C15<br>281201C15<br>281201C15                                                                                                  |
| 281201C15<br>281201C15<br>281201C15<br>281201C15                                                                                                                                | 281201C15<br>281201C15<br>281201C15<br>281201C15                                                                                                  |
| 281201C15<br>281201C15<br>281201C15<br>281201C15                                                                                                                                | 281201C15<br>281201C15<br>281201C15<br>281201C15                                                                                                  |
| 281201C15<br>281201C15<br>281201C15<br>281201C15                                                                                                                                | 281201C15<br>281201C15<br>281201C15<br>281201C15                                                                                                  |
| 281201C15<br>281201C15<br>281201C15<br>281201C15                                                                                                                                | 281201C15<br>281201C15<br>281201C15<br>281201C15                                                                                                  |
| 281201C15<br>281201C15<br>281201C15<br>281201C15                                                                                                                                | 281201C15<br>281201C15<br>281201C15<br>281201C15                                                                                                  |
| 281201C15<br>281201C15<br>281201C15<br>281201C15                                                                                                                                | 281201C15<br>281201C15<br>281201C15<br>281201C15                                                                                                  |

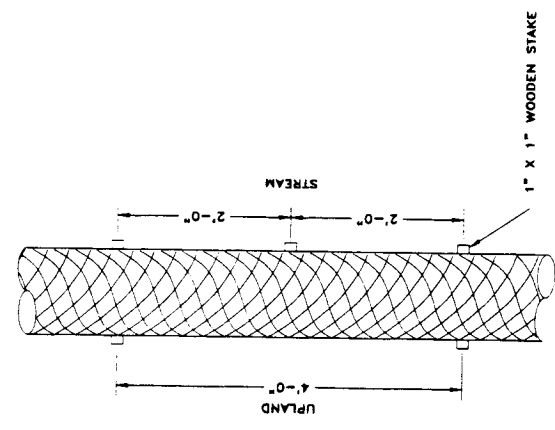
AR 049443



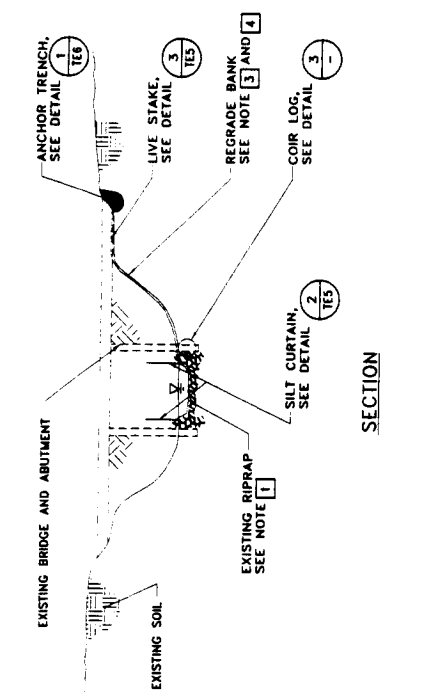




**DETAIL**  
TYPICAL DETAIL  
OF COIR FABRIC LIFTS  
NO SCALE



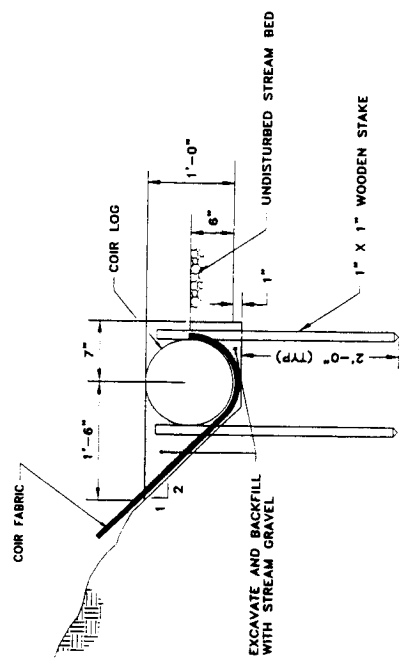
**DETAIL**  
TYPICAL DETAIL  
OF COIR LOG  
NO SCALE



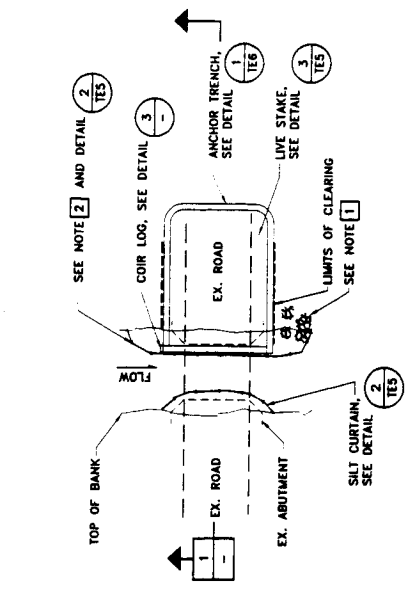
**SECTION**

**CONSTRUCTION SEQUENCE:**

1. REMOVE BRIDGE DECK
2. INSTALL SILT CURTAIN, REMOVE ABUTMENT, AND STABILIZE BANK ON ONE SIDE AT A TIME (UNLESS DIRECTED BY THE ENGINEER)



**SECTION**



**PLAN**

**DETAIL**  
TYPICAL DETAIL  
OF BRIDGE W/ ABUTMENT  
REMOVAL DETAIL  
SCALE: 1" = 10'

**GENERAL NOTES:**

- 1 REMOVE EXISTING RIPRAP AS DETERMINED BY THE ENGINEER.
- 2 INSTALL SILT CURTAIN UPSTREAM AND DOWNSTREAM OF CONSTRUCTION.
- 3 REGRADE BANKS TO MATCH EXISTING UPSTREAM AND DOWNSTREAM CROSS SECTIONS.
- 4 STABILIZE BANKS WITH EROSION CONTROL MATTING, LIVE STAKES, AND SEEDING.

**AGENCY REVIEW**  
**NOT FOR CONSTRUCTION**

|                  |                                                                                                   |
|------------------|---------------------------------------------------------------------------------------------------|
| PROJECT NO.      | 291281C7                                                                                          |
| DATE OF REVISION | STA-8606-C9                                                                                       |
| PROJECT NAME     | Port of Seattle<br>SEA-TAC INTERNATIONAL AIRPORT<br>MILLER CREEK INSTREAM AND BUFFER ENHANCEMENTS |
| PROJECT TITLE    | INSTREAM DETAILS                                                                                  |

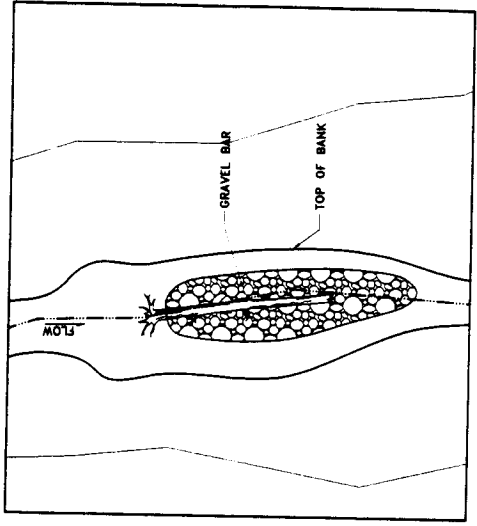
| NO. | DATE | BY | REVISIONS |
|-----|------|----|-----------|
|     |      |    |           |
|     |      |    |           |
|     |      |    |           |
|     |      |    |           |

CALL 48 HOURS BEFORE YOU DIG  
1-800-424-5555

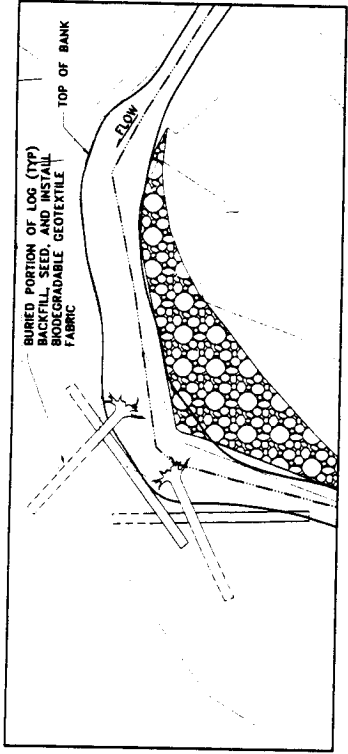
**Parametrix, Inc.**  
5808 Lk. Washington Blvd. NE  
Kirkland, WA 98033  
Ph: (425) 822-8800  
WWW.PARAMETRIX.COM

Quality Service Through Employee Ownership  
EST. 1978

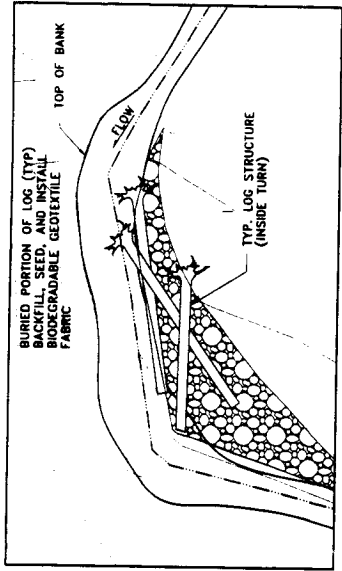
DATE: 11/17/01  
PROJECT: 291281C7  
REVISED: 11/17/01



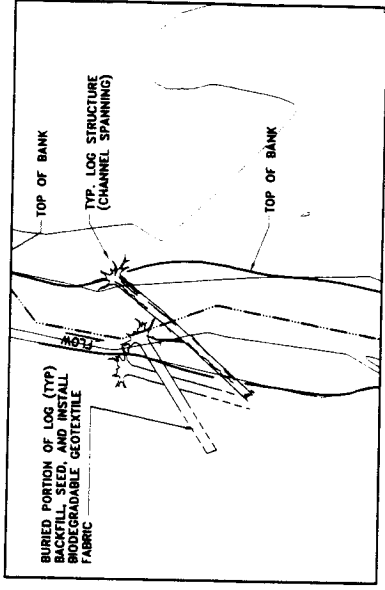
**DETAIL**  
TYPICAL DETAIL  
BAR LOG STRUCTURE  
SCALE 1" = 10'  
3  
C7



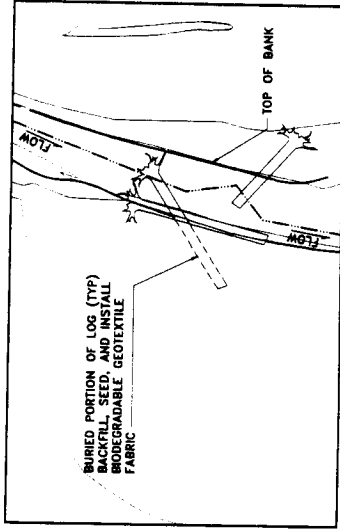
**DETAIL**  
TYPICAL DETAIL  
OUTSIDE TURN LOG STRUCTURE  
SCALE 1" = 10'  
2  
C7



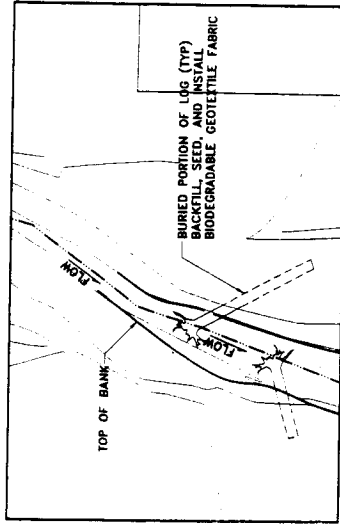
**DETAIL**  
TYPICAL DETAIL  
INSIDE TURN LOG STRUCTURE  
SCALE 1" = 10'  
1  
C7



**DETAIL**  
TYPICAL DETAIL  
CHANNEL SPANNING LOG STRUCTURE  
SCALE 1" = 10'  
6  
C3, C7



**DETAIL**  
TYPICAL DETAIL  
TURNING LOG STRUCTURE 2  
SCALE 1" = 10'  
5  
C7



**DETAIL**  
TYPICAL DETAIL  
TURNING LOG STRUCTURE 1  
SCALE 1" = 10'  
4  
C3, C7

**AGENCY REVIEW**  
**NOT FOR CONSTRUCTION**

DATE: 11/13/01  
PROJECT: 281281C12  
DRAWN BY: J. T. BROWN  
SCALE: 1" = 10'  
APPENDIX B

**Port of Seattle**  
**SEA-TAC INTERNATIONAL AIRPORT**  
MILLER CREEK INSTREAM AND BUFFER ENHANCEMENTS  
PROJECT FILE: LWD DETAILS

DATE: 11/13/01  
PROJECT: 281281C12  
DRAWN BY: J. T. BROWN  
SCALE: 1" = 10'

DATE: 11/13/01  
PROJECT: 281281C12  
DRAWN BY: J. T. BROWN  
SCALE: 1" = 10'

DATE: 11/13/01  
PROJECT: 281281C12  
DRAWN BY: J. T. BROWN  
SCALE: 1" = 10'

DATE: 11/13/01  
PROJECT: 281281C12  
DRAWN BY: J. T. BROWN  
SCALE: 1" = 10'

DATE: 11/13/01  
PROJECT: 281281C12  
DRAWN BY: J. T. BROWN  
SCALE: 1" = 10'

DATE: 11/13/01  
PROJECT: 281281C12  
DRAWN BY: J. T. BROWN  
SCALE: 1" = 10'

DATE: 11/13/01  
PROJECT: 281281C12  
DRAWN BY: J. T. BROWN  
SCALE: 1" = 10'

DATE: 11/13/01  
PROJECT: 281281C12  
DRAWN BY: J. T. BROWN  
SCALE: 1" = 10'

DATE: 11/13/01  
PROJECT: 281281C12  
DRAWN BY: J. T. BROWN  
SCALE: 1" = 10'

DATE: 11/13/01  
PROJECT: 281281C12  
DRAWN BY: J. T. BROWN  
SCALE: 1" = 10'

DATE: 11/13/01  
PROJECT: 281281C12  
DRAWN BY: J. T. BROWN  
SCALE: 1" = 10'

DATE: 11/13/01  
PROJECT: 281281C12  
DRAWN BY: J. T. BROWN  
SCALE: 1" = 10'

DATE: 11/13/01  
PROJECT: 281281C12  
DRAWN BY: J. T. BROWN  
SCALE: 1" = 10'

DATE: 11/13/01  
PROJECT: 281281C12  
DRAWN BY: J. T. BROWN  
SCALE: 1" = 10'

DATE: 11/13/01  
PROJECT: 281281C12  
DRAWN BY: J. T. BROWN  
SCALE: 1" = 10'

DATE: 11/13/01  
PROJECT: 281281C12  
DRAWN BY: J. T. BROWN  
SCALE: 1" = 10'

DATE: 11/13/01  
PROJECT: 281281C12  
DRAWN BY: J. T. BROWN  
SCALE: 1" = 10'

DATE: 11/13/01  
PROJECT: 281281C12  
DRAWN BY: J. T. BROWN  
SCALE: 1" = 10'

CALL 48 HOURS  
BEFORE YOU DIG  
1-800-24-5555

**Parametrix, Inc.**  
5008 Lk. Washington Blvd. NE  
Kirkland, WA 98033  
Ph: (425) 822-8800

Quality Service Through Employee Ownership  
P. T. BROWN

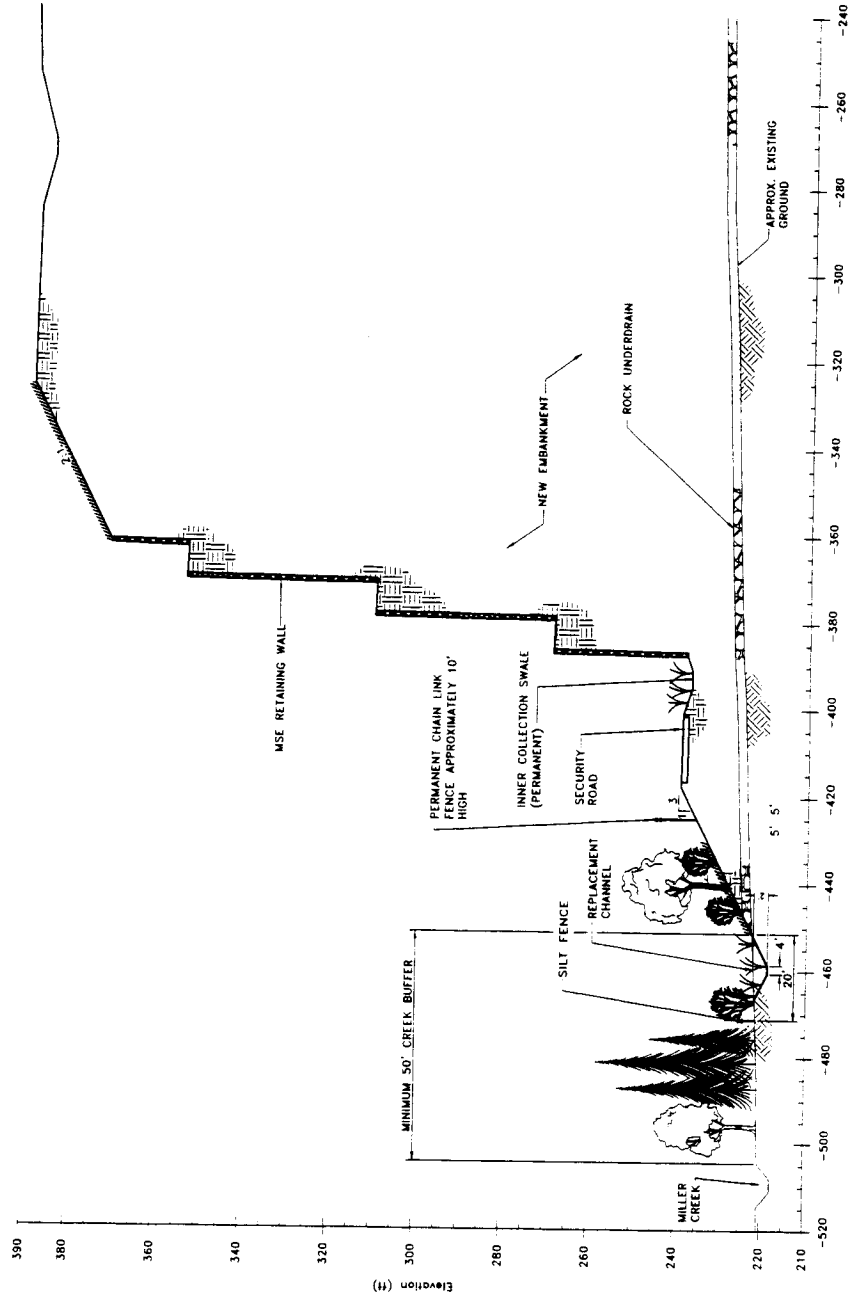
2812018A2

2812815V

281201W

2812810E

AR 049446



**SECTION 1 C2**  
**STREAM BUFFER AND EMBANKMENT**  
 HO SCALE

**AGENCY REVIEW  
 NOT FOR CONSTRUCTION**

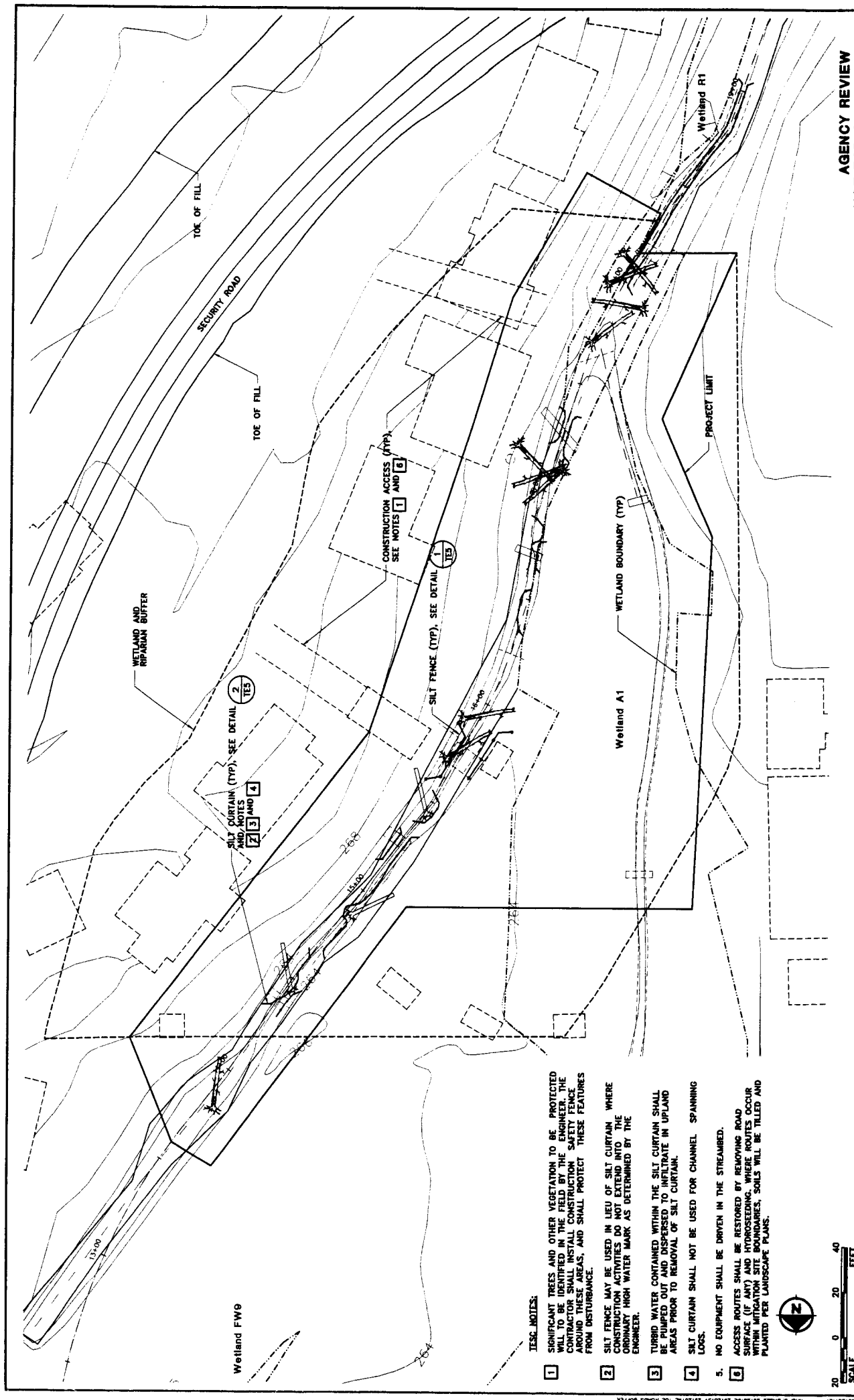
| <b>Paramatrix, Inc.</b><br>5608 Lt. Washington Blvd. NE<br>Kirkland, WA 98033<br>PH: (425) 822-8880<br><i>Quality Services Through Employee Ownership</i><br>P. T. T. |      | <b>REVISIONS</b><br><table border="1"> <thead> <tr> <th>NO.</th> <th>DATE</th> <th>BY</th> <th>DESCRIPTION</th> </tr> </thead> <tbody> <tr> <td> </td> <td> </td> <td> </td> <td> </td> </tr> <tr> <td> </td> <td> </td> <td> </td> <td> </td> </tr> <tr> <td> </td> <td> </td> <td> </td> <td> </td> </tr> </tbody> </table> |             | NO. | DATE | BY | DESCRIPTION |  |  |  |  |  |  |  |  |  |  |  |  | <b>PROJECT INFORMATION</b><br>PROJECT: SEA-TAC INTERNATIONAL AIRPORT<br>MILLER CREEK INSTREAM AND BUFFER ENHANCEMENTS<br>SHEET NO.: STREAM BUFFER AND EMBANKMENT CROSS-SECTION<br>DRAWING NO.: 281281C17<br>DATE OF SHEET: STA. 8008-C11<br>APPENDIX B |  |
|-----------------------------------------------------------------------------------------------------------------------------------------------------------------------|------|-------------------------------------------------------------------------------------------------------------------------------------------------------------------------------------------------------------------------------------------------------------------------------------------------------------------------------|-------------|-----|------|----|-------------|--|--|--|--|--|--|--|--|--|--|--|--|--------------------------------------------------------------------------------------------------------------------------------------------------------------------------------------------------------------------------------------------------------|--|
| NO.                                                                                                                                                                   | DATE | BY                                                                                                                                                                                                                                                                                                                            | DESCRIPTION |     |      |    |             |  |  |  |  |  |  |  |  |  |  |  |  |                                                                                                                                                                                                                                                        |  |
|                                                                                                                                                                       |      |                                                                                                                                                                                                                                                                                                                               |             |     |      |    |             |  |  |  |  |  |  |  |  |  |  |  |  |                                                                                                                                                                                                                                                        |  |
|                                                                                                                                                                       |      |                                                                                                                                                                                                                                                                                                                               |             |     |      |    |             |  |  |  |  |  |  |  |  |  |  |  |  |                                                                                                                                                                                                                                                        |  |
|                                                                                                                                                                       |      |                                                                                                                                                                                                                                                                                                                               |             |     |      |    |             |  |  |  |  |  |  |  |  |  |  |  |  |                                                                                                                                                                                                                                                        |  |

CALL 48 HOURS BEFORE YOU DIG  
 1-800-424-3830

AR 049447





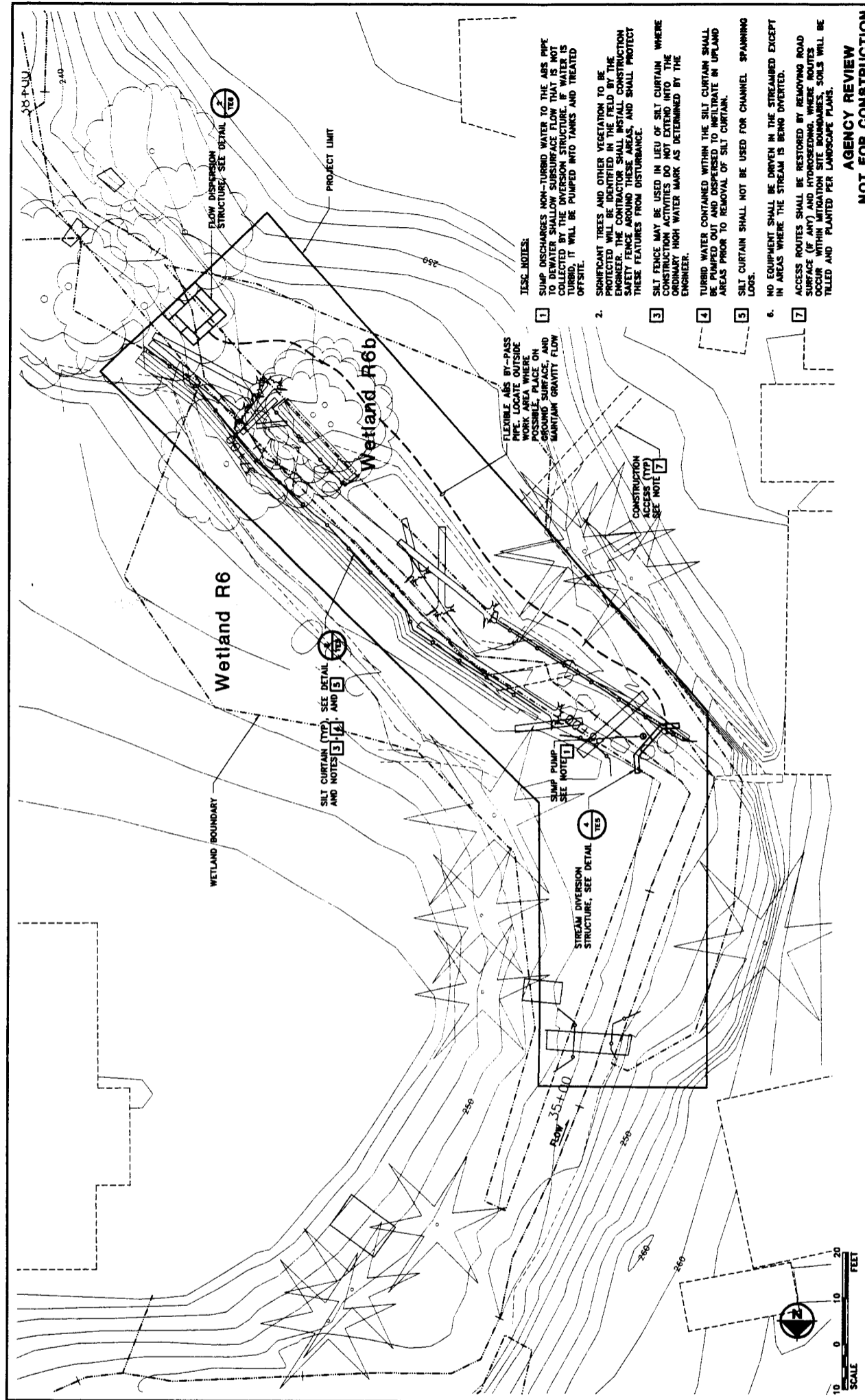


| <p><b>AGENCY REVIEW NOT FOR CONSTRUCTION</b></p> <p><b>Port of Seattle</b><br/> <b>SEA-TAC INTERNATIONAL AIRPORT</b><br/> <b>MILLER CREEK INSTREAM AND BUFFER ENHANCEMENTS</b><br/> <b>PROJECT ROAD - PROJECT AREA 1</b></p>                                                                                                                                                                                                                                                                                                                                                                                                                                              |                  |      |             |             |  |  |  |  |  |  |  |  |  |  |  |  |  |  |  |  |  |  |  |  |  |  |  |  |  |  |  |  |  |  |  |  |  |  |  |  |  |  |  |  |                  |
|---------------------------------------------------------------------------------------------------------------------------------------------------------------------------------------------------------------------------------------------------------------------------------------------------------------------------------------------------------------------------------------------------------------------------------------------------------------------------------------------------------------------------------------------------------------------------------------------------------------------------------------------------------------------------|------------------|------|-------------|-------------|--|--|--|--|--|--|--|--|--|--|--|--|--|--|--|--|--|--|--|--|--|--|--|--|--|--|--|--|--|--|--|--|--|--|--|--|--|--|--|--|------------------|
| DATE: 11/20/01                                                                                                                                                                                                                                                                                                                                                                                                                                                                                                                                                                                                                                                            | 2012018A2        |      |             |             |  |  |  |  |  |  |  |  |  |  |  |  |  |  |  |  |  |  |  |  |  |  |  |  |  |  |  |  |  |  |  |  |  |  |  |  |  |  |  |  |                  |
| SCALE: 20' 0" 20' 40' FEET                                                                                                                                                                                                                                                                                                                                                                                                                                                                                                                                                                                                                                                | 2012018A2        |      |             |             |  |  |  |  |  |  |  |  |  |  |  |  |  |  |  |  |  |  |  |  |  |  |  |  |  |  |  |  |  |  |  |  |  |  |  |  |  |  |  |  |                  |
| <p>CALL 48 HOURS BEFORE YOU DIG<br/>         1-800-424-5855</p>                                                                                                                                                                                                                                                                                                                                                                                                                                                                                                                                                                                                           | <p>2012018A2</p> |      |             |             |  |  |  |  |  |  |  |  |  |  |  |  |  |  |  |  |  |  |  |  |  |  |  |  |  |  |  |  |  |  |  |  |  |  |  |  |  |  |  |  |                  |
| <p><b>Parametrix, Inc.</b><br/>         5808 Lk. Washington Blvd. NE<br/>         Redmond, WA 98053<br/>         Ph: (425) 822-8880</p>                                                                                                                                                                                                                                                                                                                                                                                                                                                                                                                                   | <p>2012018A2</p> |      |             |             |  |  |  |  |  |  |  |  |  |  |  |  |  |  |  |  |  |  |  |  |  |  |  |  |  |  |  |  |  |  |  |  |  |  |  |  |  |  |  |  |                  |
| <p>Quality Services Through Employee Ownership<br/>         P. 12007</p>                                                                                                                                                                                                                                                                                                                                                                                                                                                                                                                                                                                                  | <p>2012018A2</p> |      |             |             |  |  |  |  |  |  |  |  |  |  |  |  |  |  |  |  |  |  |  |  |  |  |  |  |  |  |  |  |  |  |  |  |  |  |  |  |  |  |  |  |                  |
| <p>REVISIONS</p> <table border="1"> <thead> <tr> <th>NO.</th> <th>DATE</th> <th>BY</th> <th>DESCRIPTION</th> </tr> </thead> <tbody> <tr><td> </td><td> </td><td> </td><td> </td></tr> <tr><td> </td><td> </td><td> </td><td> </td></tr> <tr><td> </td><td> </td><td> </td><td> </td></tr> <tr><td> </td><td> </td><td> </td><td> </td></tr> <tr><td> </td><td> </td><td> </td><td> </td></tr> <tr><td> </td><td> </td><td> </td><td> </td></tr> <tr><td> </td><td> </td><td> </td><td> </td></tr> <tr><td> </td><td> </td><td> </td><td> </td></tr> <tr><td> </td><td> </td><td> </td><td> </td></tr> <tr><td> </td><td> </td><td> </td><td> </td></tr> </tbody> </table> | NO.              | DATE | BY          | DESCRIPTION |  |  |  |  |  |  |  |  |  |  |  |  |  |  |  |  |  |  |  |  |  |  |  |  |  |  |  |  |  |  |  |  |  |  |  |  |  |  |  |  | <p>2012018A2</p> |
| NO.                                                                                                                                                                                                                                                                                                                                                                                                                                                                                                                                                                                                                                                                       | DATE             | BY   | DESCRIPTION |             |  |  |  |  |  |  |  |  |  |  |  |  |  |  |  |  |  |  |  |  |  |  |  |  |  |  |  |  |  |  |  |  |  |  |  |  |  |  |  |  |                  |
|                                                                                                                                                                                                                                                                                                                                                                                                                                                                                                                                                                                                                                                                           |                  |      |             |             |  |  |  |  |  |  |  |  |  |  |  |  |  |  |  |  |  |  |  |  |  |  |  |  |  |  |  |  |  |  |  |  |  |  |  |  |  |  |  |  |                  |
|                                                                                                                                                                                                                                                                                                                                                                                                                                                                                                                                                                                                                                                                           |                  |      |             |             |  |  |  |  |  |  |  |  |  |  |  |  |  |  |  |  |  |  |  |  |  |  |  |  |  |  |  |  |  |  |  |  |  |  |  |  |  |  |  |  |                  |
|                                                                                                                                                                                                                                                                                                                                                                                                                                                                                                                                                                                                                                                                           |                  |      |             |             |  |  |  |  |  |  |  |  |  |  |  |  |  |  |  |  |  |  |  |  |  |  |  |  |  |  |  |  |  |  |  |  |  |  |  |  |  |  |  |  |                  |
|                                                                                                                                                                                                                                                                                                                                                                                                                                                                                                                                                                                                                                                                           |                  |      |             |             |  |  |  |  |  |  |  |  |  |  |  |  |  |  |  |  |  |  |  |  |  |  |  |  |  |  |  |  |  |  |  |  |  |  |  |  |  |  |  |  |                  |
|                                                                                                                                                                                                                                                                                                                                                                                                                                                                                                                                                                                                                                                                           |                  |      |             |             |  |  |  |  |  |  |  |  |  |  |  |  |  |  |  |  |  |  |  |  |  |  |  |  |  |  |  |  |  |  |  |  |  |  |  |  |  |  |  |  |                  |
|                                                                                                                                                                                                                                                                                                                                                                                                                                                                                                                                                                                                                                                                           |                  |      |             |             |  |  |  |  |  |  |  |  |  |  |  |  |  |  |  |  |  |  |  |  |  |  |  |  |  |  |  |  |  |  |  |  |  |  |  |  |  |  |  |  |                  |
|                                                                                                                                                                                                                                                                                                                                                                                                                                                                                                                                                                                                                                                                           |                  |      |             |             |  |  |  |  |  |  |  |  |  |  |  |  |  |  |  |  |  |  |  |  |  |  |  |  |  |  |  |  |  |  |  |  |  |  |  |  |  |  |  |  |                  |
|                                                                                                                                                                                                                                                                                                                                                                                                                                                                                                                                                                                                                                                                           |                  |      |             |             |  |  |  |  |  |  |  |  |  |  |  |  |  |  |  |  |  |  |  |  |  |  |  |  |  |  |  |  |  |  |  |  |  |  |  |  |  |  |  |  |                  |
|                                                                                                                                                                                                                                                                                                                                                                                                                                                                                                                                                                                                                                                                           |                  |      |             |             |  |  |  |  |  |  |  |  |  |  |  |  |  |  |  |  |  |  |  |  |  |  |  |  |  |  |  |  |  |  |  |  |  |  |  |  |  |  |  |  |                  |
|                                                                                                                                                                                                                                                                                                                                                                                                                                                                                                                                                                                                                                                                           |                  |      |             |             |  |  |  |  |  |  |  |  |  |  |  |  |  |  |  |  |  |  |  |  |  |  |  |  |  |  |  |  |  |  |  |  |  |  |  |  |  |  |  |  |                  |
| <p>DATE: 11/20/01</p>                                                                                                                                                                                                                                                                                                                                                                                                                                                                                                                                                                                                                                                     | <p>2012018A2</p> |      |             |             |  |  |  |  |  |  |  |  |  |  |  |  |  |  |  |  |  |  |  |  |  |  |  |  |  |  |  |  |  |  |  |  |  |  |  |  |  |  |  |  |                  |
| <p>PLANS: 2012018A2</p>                                                                                                                                                                                                                                                                                                                                                                                                                                                                                                                                                                                                                                                   | <p>2012018A2</p> |      |             |             |  |  |  |  |  |  |  |  |  |  |  |  |  |  |  |  |  |  |  |  |  |  |  |  |  |  |  |  |  |  |  |  |  |  |  |  |  |  |  |  |                  |
| <p>FILES: 0452 0453 0454 0455 0456 0457 0458 0459 0460 0461 0462 0463 0464 0465 0466 0467 0468 0469 0470 0471 0472 0473 0474 0475 0476 0477 0478 0479 0480 0481 0482 0483 0484 0485 0486 0487 0488 0489 0490 0491 0492 0493 0494 0495 0496 0497 0498 0499 0500</p>                                                                                                                                                                                                                                                                                                                                                                                                        | <p>2012018A2</p> |      |             |             |  |  |  |  |  |  |  |  |  |  |  |  |  |  |  |  |  |  |  |  |  |  |  |  |  |  |  |  |  |  |  |  |  |  |  |  |  |  |  |  |                  |

- TESC NOTES:**
- SIGNIFICANT TREES AND OTHER VEGETATION TO BE PROTECTED WILL TO BE IDENTIFIED IN THE FIELD BY THE ENGINEER. THE CONTRACTOR SHALL INSTALL CONSTRUCTION SAFETY FENCE AROUND THESE AREAS, AND SHALL PROTECT THESE FEATURES FROM DISTURBANCE.
  - SILT FENCE MAY BE USED IN LIEU OF SILT CURTAIN WHERE CONSTRUCTION ACTIVITIES DO NOT EXTEND INTO THE ORDINARY HIGH WATER MARK AS DETERMINED BY THE ENGINEER.
  - TURBID WATER CONTAINED WITHIN THE SILT CURTAIN SHALL BE SKIMMED OUT AND DISPERSED TO INFILTRATE IN UPLAND AREAS PRIOR TO REMOVAL OF SILT CURTAIN.
  - SILT CURTAIN SHALL NOT BE USED FOR CHANNEL SPANNING LOGS.
  - NO EQUIPMENT SHALL BE DRIVEN IN THE STREAMBED.
  - ACCESS ROUTES SHALL BE RESTORED BY REMOVING ROAD SURFACE (IF ANY) AND HYDROSEEDING WHERE ROUTES OCCUR WITHIN MITIGATION SITE BOUNDARIES. SOILS WILL BE TILLED AND PLANTED PER LANDSCAPE PLANS.



AR 049450



**REVISIONS**

- 1. SUMP DISCHARGES NON-TURBID WATER TO THE AAS PIPE TO DEWATER SHALLOW SURFACE FLOW THAT IS NOT COLLECTED BY THE DIVERSION STRUCTURE. IF WATER IS TURBID, IT WILL BE PUMPED INTO TANKS AND TREATED OFFSITE.
- 2. SIGNIFICANT TREES AND OTHER VEGETATION TO BE REMOVED SHALL BE IDENTIFIED AND THE FIELD BY THE ENGINEER. THE CONTRACTOR SHALL CONSTRUCT A SAFETY FENCE AROUND THESE AREAS, AND SHALL PROTECT THESE FEATURES FROM DISTURBANCE.
- 3. SILT FENCE MAY BE USED IN LIEU OF SILT CURTAIN WHERE CONSTRUCTION ACTIVITIES DO NOT EXTEND INTO THE CHANNEL AND WHERE HIGH WATER MARK AS DETERMINED BY THE ENGINEER.
- 4. TURBID WATER CONTAINED WITHIN THE SILT CURTAIN SHALL BE PUMPED OUT AND DISPERSED TO INFILTRATE IN UPLAND AREAS PRIOR TO REMOVAL OF SILT CURTAIN.
- 5. SILT CURTAIN SHALL NOT BE USED FOR CHANNEL SPANNING LOS.
- 6. NO EQUIPMENT SHALL BE DRIVEN IN THE STREAMBED EXCEPT IN AREAS WHERE THE STREAM IS BEING DIVERTED.
- 7. ACCESS ROUTES SHALL BE RESTORED BY REMOVING ROAD SURFACE (IF ANY) AND HYDROSEEDING. WHERE ROUTES OCCUR WITHIN MITIGATION SITE BOUNDARIES, SOILS WILL BE FILLED AND PLANTED PER LANDSCAPE PLANS.

FLEXIBLE AAS BY-PASS PIPE. LOCATE OUTSIDE WORK AREA WHERE POSSIBLE. PLACE ON GROUND SURFACE, AND MAINTAIN GRAVITY FLOW.

CONSTRUCTION ACCESS (TYP) SEE NOTE 7

SILT CURTAIN (TYP), SEE DETAIL AND NOTES 3, 4, 5

SUMP PUMP, SEE NOTE 1

STREAM DIVERSION STRUCTURE, SEE DETAIL 4

Wetland R6

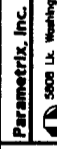
Wetland R6b

WETLAND BOUNDARY

PROJECT LIMIT

FLOW DISPERSION STRUCTURE, SEE DETAIL 2

CALL US HOURS BEFORE YOU DIG  
1-800-424-5555



Parametric, Inc.  
5808 Lt. Washington, Blvd. NE  
Kirkland, WA 98033  
Ph: (425) 822-8880

PROJECT NO. 281201842  
DATE: 11/28/20  
SCALE: AS SHOWN  
DRAWN: J. B. BAKER  
CHECKED: J. B. BAKER  
APPROVED: J. B. BAKER

CONTRACT NO. 281201842  
SHEET NO. 281201842-01  
DATE: 11/28/20

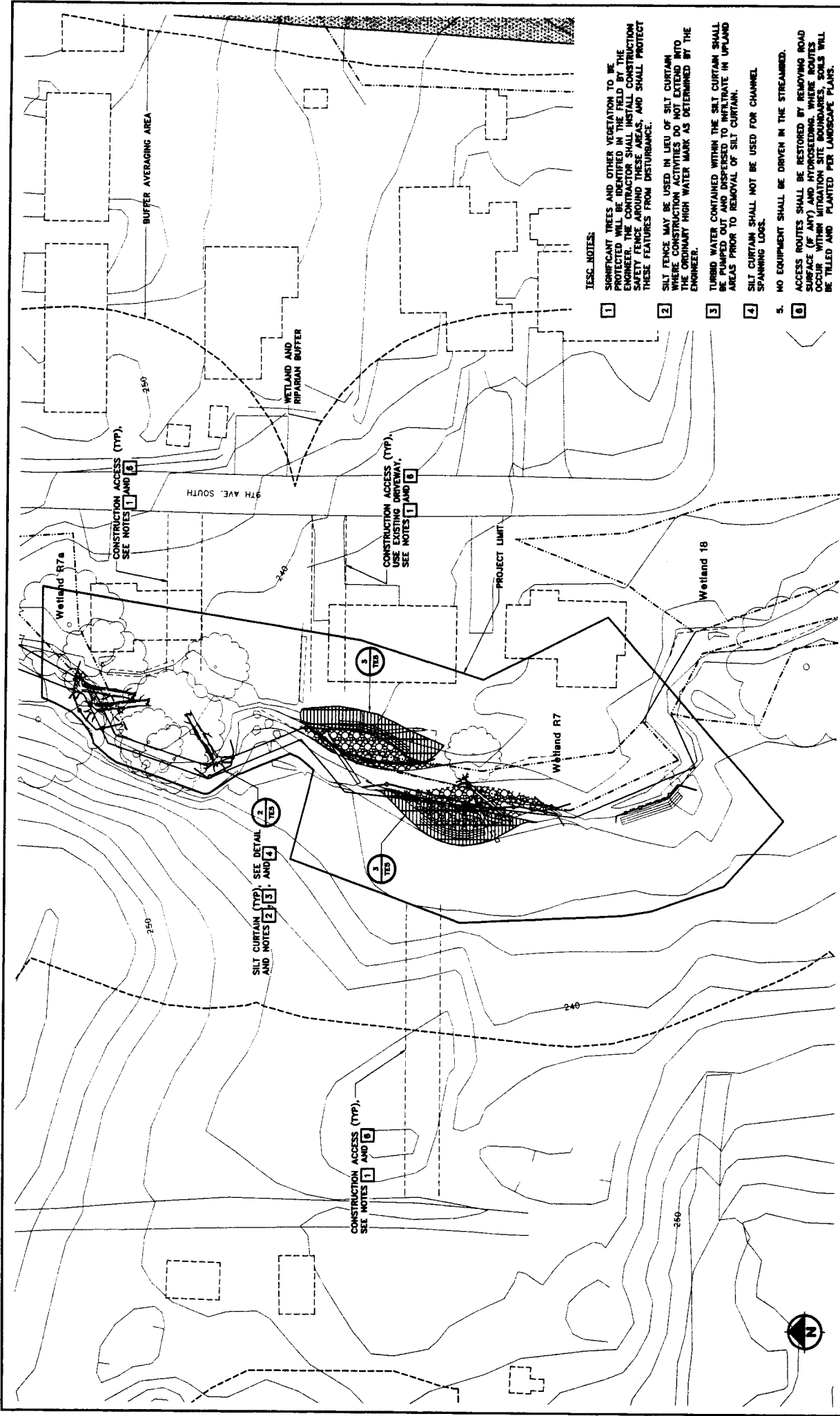
| NO. | DATE | DESCRIPTION | BY | CHECKED |
|-----|------|-------------|----|---------|
|     |      |             |    |         |
|     |      |             |    |         |
|     |      |             |    |         |
|     |      |             |    |         |
|     |      |             |    |         |
|     |      |             |    |         |
|     |      |             |    |         |
|     |      |             |    |         |
|     |      |             |    |         |

281201842  
281201842-01  
281201842

**AGENCY REVIEW NOT FOR CONSTRUCTION**

Port of Seattle  
SEA-TAC INTERNATIONAL AIRPORT  
MILLER CREEK INSTREAM AND BUFFER ENHANCEMENTS  
PROJECT NO. 281201842  
SHEET NO. 281201842-01  
DATE: 11/28/20  
SCALE: AS SHOWN  
DRAWN: J. B. BAKER  
CHECKED: J. B. BAKER  
APPROVED: J. B. BAKER

AR 049451



- IEEC NOTES:**
1. SIGNIFICANT TREES AND OTHER VEGETATION TO BE PROTECTED WILL BE IDENTIFIED IN THE FIELD BY THE ENGINEER. THE CONTRACTOR SHALL INSTALL CONSTRUCTION SAFETY FENCE AROUND THESE AREAS, AND SHALL PROTECT THESE FEATURES FROM DISTURBANCE.
  2. SILT FENCE MAY BE USED, IN LIEU OF SILT CURTAIN WHERE CONSTRUCTION ACTIVITIES DO NOT EXTEND INTO THE ORDINARY HIGH WATER MARK AS DETERMINED BY THE ENGINEER.
  3. TURBID WATER CONTAINED WITHIN THE SILT CURTAIN SHALL BE PUMPED OUT AND DISPERSED TO INFILTRATE IN UPLAND AREAS PRIOR TO REMOVAL OF SILT CURTAIN.
  4. SILT CURTAIN SHALL NOT BE USED FOR CHANNEL SPANNING LOGS.
  5. NO EQUIPMENT SHALL BE DRIVEN IN THE STREAMBED.
  6. ACCESS ROUTES SHALL BE RESTORED BY REMOVING ROAD SURFACE (AS APPLICABLE) AND REPAIRING UNDERLYING ROUTES OCCUR WITHIN MITIGATION SILENT BOUNDARIES. SOILS WILL BE TILLED AND PLANTED PER LANDSCAPE PLANS.

**AGENCY REVIEW  
NOT FOR CONSTRUCTION**

**Parametrix, Inc.**  
 5808 Lt. Washington Blvd. NE  
 Kirkland, WA 98033  
 P: (425) 822-8800  
 Fax: (425) 822-8801  
 Email: info@parametrix.com  
 Website: www.parametrix.com  
 Project No.: 2812815X

**SEA-TAO INTERNATIONAL AIRPORT**  
 MILLER CREEK INSTREAM AND BUFFER ENHANCEMENTS  
**TEEC PLAN - PROJECT AREA 3**

DATE: 11/12/01 FILENAME: 2812815X.DWG  
 DATE: 04/28/2014 FILENAME: 2812815X.DWG  
 DATE: 04/28/2014 FILENAME: 2812815X.DWG

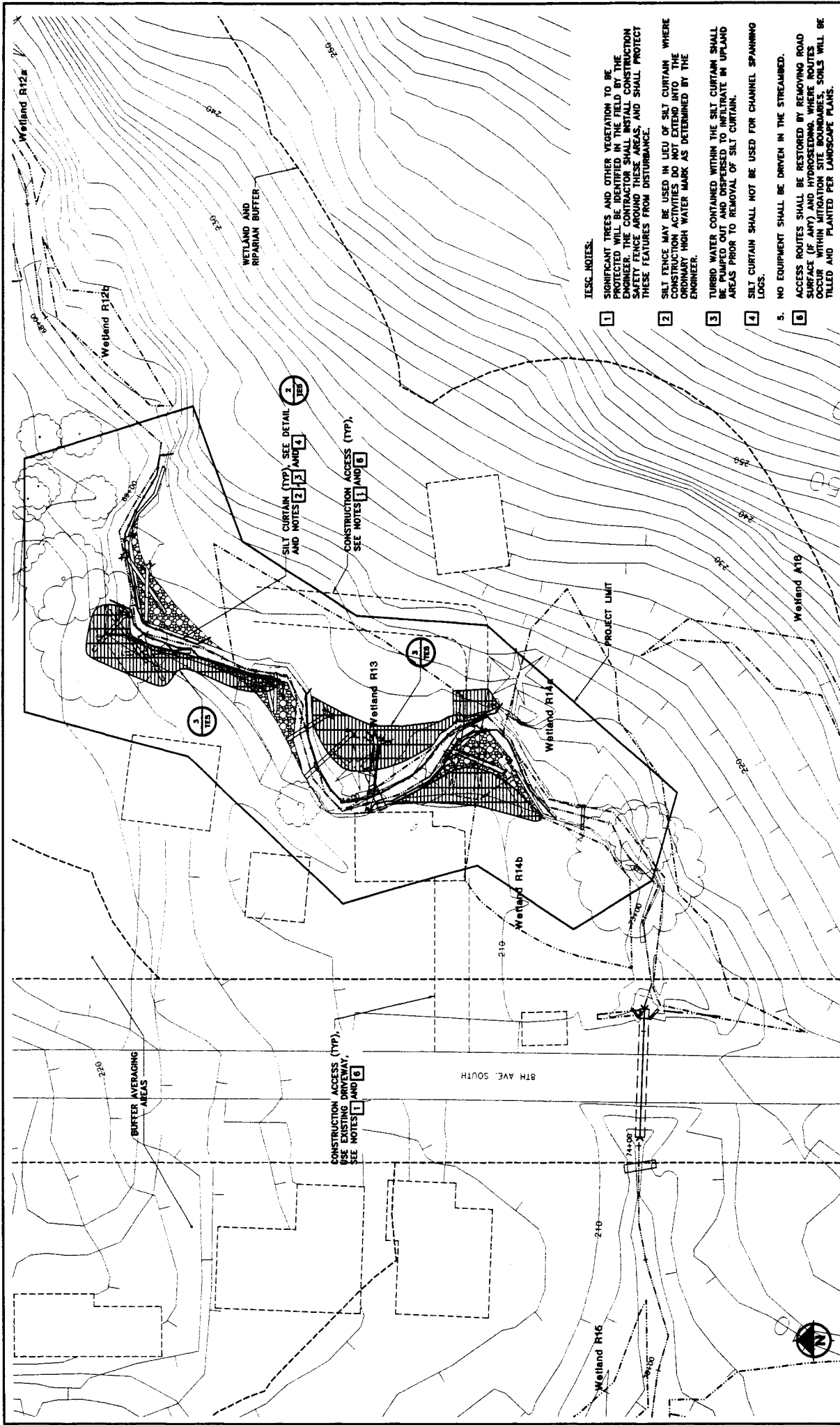
SCALE: 0 20 40 FEET

CALL 48 HOURS BEFORE YOU DIG 1-800-44-5555

2812815X

AR 049452





- TESC NOTES:**
- 1 SIGNIFICANT TREES AND OTHER VEGETATION TO BE PROTECTED WILL BE IDENTIFIED IN THE FIELD BY THE ENGINEER. THE CONTRACTOR SHALL INSTALL CONSTRUCTION SAFETY FENCE AROUND THESE AREAS, AND SHALL PROTECT THESE FEATURES FROM DISTURBANCE.
  - 2 SILT CURTAIN (TYP.) SEE DETAIL 2 AND NOTES 2, 3 AND 4.
  - 3 CONSTRUCTION ACCESS (TYP.) SEE NOTES 1 AND 6.
  - 4 SILT CURTAIN SHALL NOT BE USED FOR CHANNEL SPANNING LOGS.
  - 5 NO EQUIPMENT SHALL BE DRIVEN IN THE STREAMBED.
  - 6 ACCESS ROUTES SHALL BE RESTORED BY REMOVING ROAD SURFACE MATERIAL TO ORIGINAL GRADE AND REGRADING TO OCCUR WITHIN MITIGATION SITE BOUNDARIES. SOILS WILL BE TILLED AND PLANTED PER LANDSCAPE PLANS.

**AGENCY REVIEW NOT FOR CONSTRUCTION**

Part of Seattle SEA-TAC INTERNATIONAL AIRPORT MILLER CREEK INSTREAM AND BUFFER ENHANCEMENTS TESC PLAN - PROJECT AREA 4

| NO. | DATE | BY | DESCRIPTION |
|-----|------|----|-------------|
|     |      |    |             |
|     |      |    |             |
|     |      |    |             |
|     |      |    |             |

| NO. | DATE | BY | DESCRIPTION |
|-----|------|----|-------------|
|     |      |    |             |
|     |      |    |             |
|     |      |    |             |
|     |      |    |             |

| NO. | DATE | BY | DESCRIPTION |
|-----|------|----|-------------|
|     |      |    |             |
|     |      |    |             |
|     |      |    |             |
|     |      |    |             |

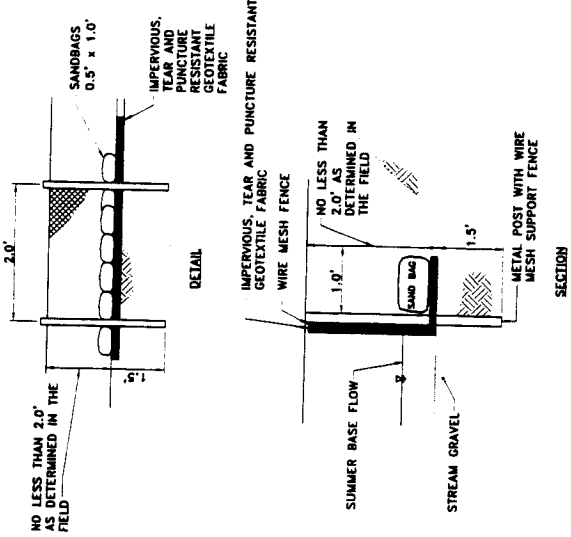
CALL 48 HOURS BEFORE WORK BEGINS 1-800-424-0855

**Parametrix, Inc.**  
 9908 Lt. Washington Blvd. NE  
 Kirkland, WA 98033  
 P.O. Box 822-0855  
 Quality Service Through Employee Ownership

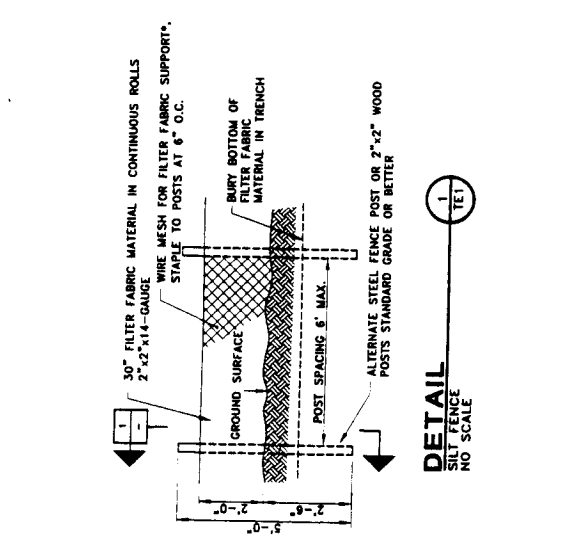
DATE: 11/13/07  
 PLDW: BAE 281281SV 281201NL 281281DE ROADS TDC B/P/FC

281201BAZ 281281DE 281201WJ 281281SY 281201WL APPENDIX B

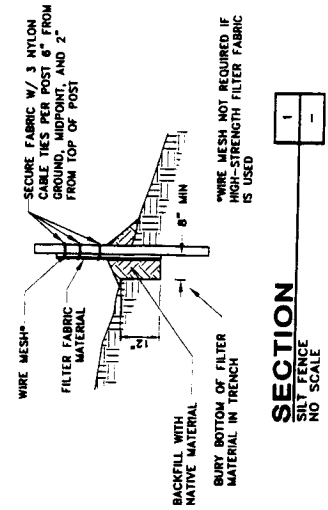
AR 049453



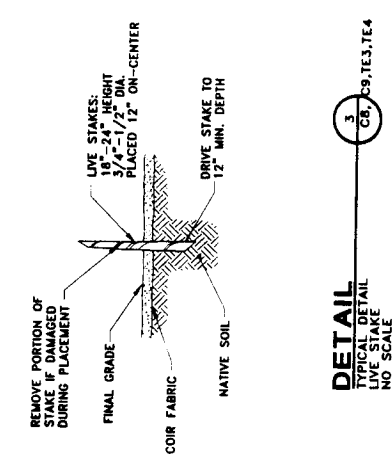
**DETAIL**  
TYPICAL  
SILT CURTAIN INSTALLATION  
NO SCALE  
GS, TE1, TE2, TE3, TE4



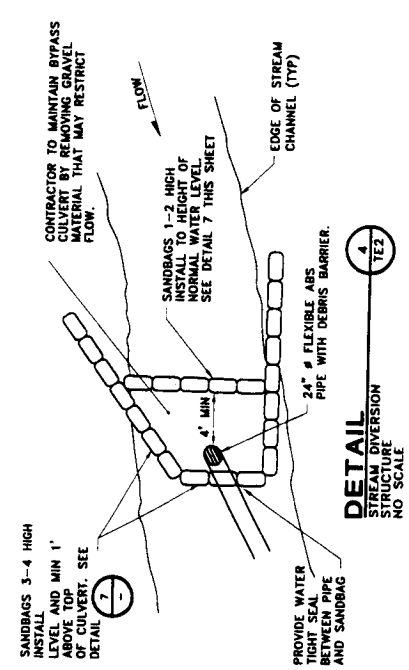
**DETAIL**  
SILT FENCE  
NO SCALE  
TE1



**SECTION**  
SILT FENCE  
NO SCALE



**DETAIL**  
TYPICAL DETAIL  
LIVE STAKE  
NO SCALE  
GS, GS9, TE3, TE4



**DETAIL**  
STREAM DIVERSION  
STRUCTURE  
NO SCALE  
TE2

**AGENCY REVIEW NOT FOR CONSTRUCTION**

281201842  
281201842

**Parametrix, Inc.**  
6808 L.L. Washington Blvd. NE  
Bellevue, WA 98003  
Ph: (425) 822-8800  
Quality Service Through Employee Ownership  
P. 10/07

281201842  
281201842

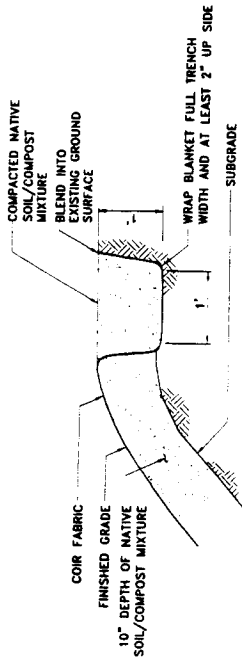
**Periodically SEA-TAC INTERNATIONAL AIRPORT**  
PROJECT: MILLER CREEK INSTREAM AND BUFFER ENHANCEMENTS  
SHEET NO.: TESC DETAILS

281201842  
281201842

DATE: 11/27/07  
DRAWN: 281201842

APPENDIX B  
STA-8804-TES

AR 049454



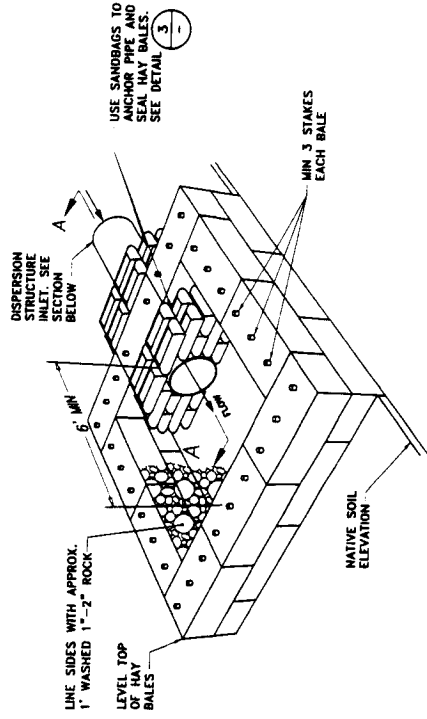
**DETAIL 1**  
TYPICAL DETAIL  
ANCHOR TRENCH  
NO SCALE



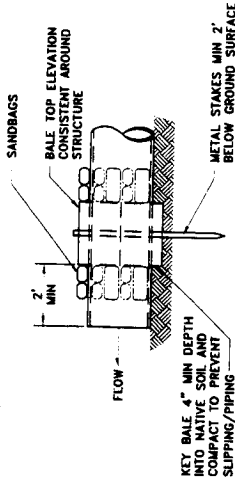
**DETAIL 2**  
SANDBAG BERM  
NO SCALE

**NOTES:**

1. WHEN SANDBAG IS FILLED WITH COARSE GRADE SAND MATERIAL, THE OPEN END SHOULD BE STAPLED OR TIED WITH NYLON OR POLY CORD. THE WEIGHT SHALL BE 90 - 125 LBS.
2. SANDBAGS SHOULD BE STACKED IN AT LEAST THREE VERTICAL ROWS ABUTTING EACH OTHER, AND IN STAGGERED ARRANGEMENT. (REFER TO FRONT VIEW).
3. THE BASE OF THE BERM SHOULD BE AT LEAST 3 SANDBAGS DEEP AND CAN BE REDUCED TO 2 AND 1 BAG IN THE SECOND AND THIRD ROWS RESPECTIVELY. (REFER TO CROSS SECTION).



**PLAN**



**SECTION A**

**DETAIL 2**  
FLOW DISPERSION STRUCTURE  
NO SCALE

**AGENCY REVIEW**  
**NOT FOR CONSTRUCTION**

STN-9009-TEE  
APPENDIX B

Part of Seattle  
SEA-TAC INTERNATIONAL AIRPORT  
MILLER CREEK INSTREAM AND BUFFER ENHANCEMENTS  
PROJECT SHEET NO. TESC DETAILS

|                  |          |
|------------------|----------|
| PROJECT NO.      | 291201E6 |
| DATE OF SHEET    | 11/11/11 |
| DATE OF REVISION |          |
| DESIGNED BY      |          |
| CHECKED BY       |          |
| APPROVED BY      |          |

|     |      |    |             |
|-----|------|----|-------------|
| NO. | DATE | BY | DESCRIPTION |
|     |      |    |             |
|     |      |    |             |
|     |      |    |             |

|     |      |    |             |
|-----|------|----|-------------|
| NO. | DATE | BY | DESCRIPTION |
|     |      |    |             |
|     |      |    |             |
|     |      |    |             |

|     |      |    |             |
|-----|------|----|-------------|
| NO. | DATE | BY | DESCRIPTION |
|     |      |    |             |
|     |      |    |             |
|     |      |    |             |

**Parametrix, Inc.**  
5808 Lt. Washington Blvd. NE  
Kirkland, WA 98033  
Ph: (425) 822-8800  
Quality Service Through Employee Ownership

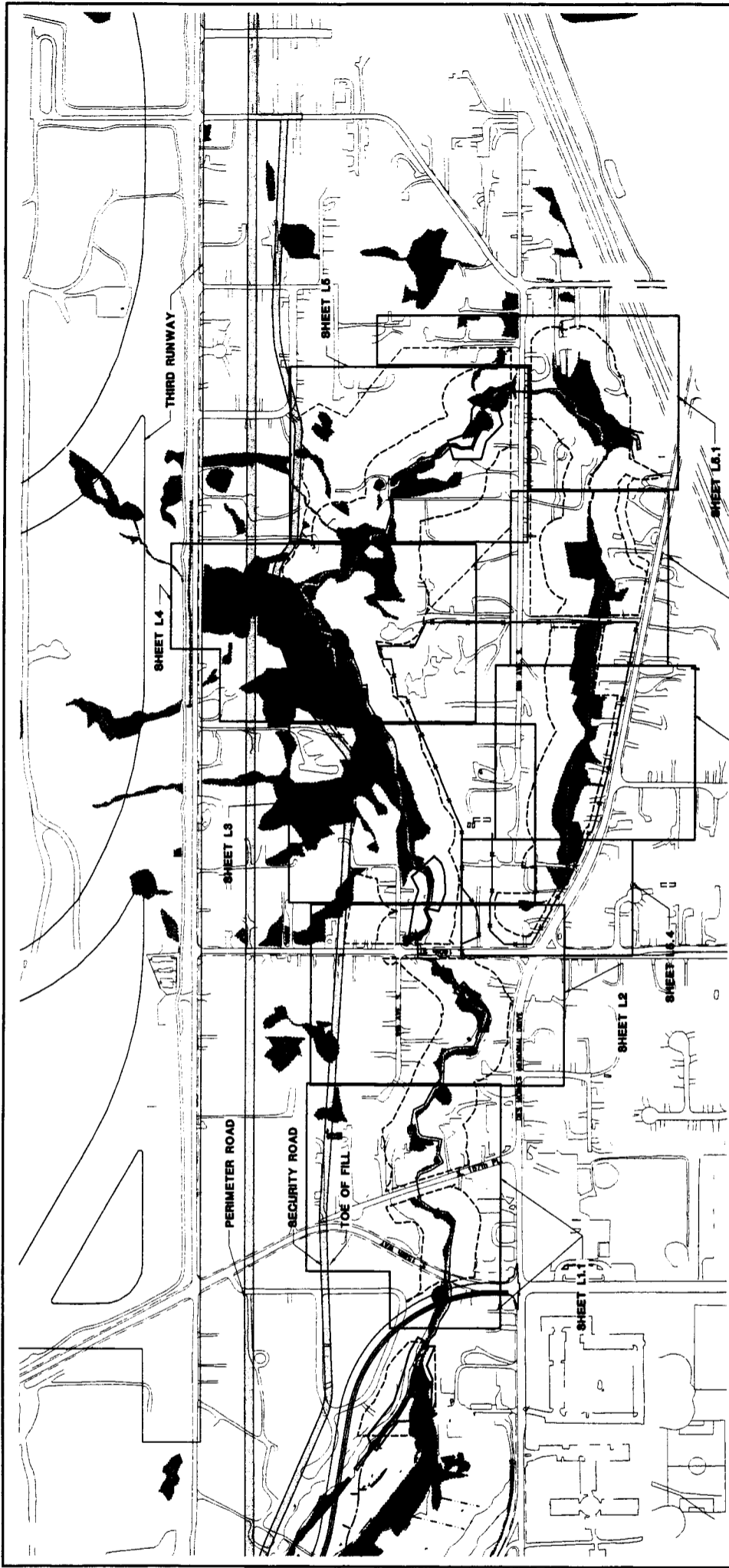
CALL 46 HOURS BEFORE YOU DIG  
1-800-424-5555

291201BA2

291201SV

291201VA

AR 049455



SCALE  
200 0 200 400  
FEET

CALL 48 HOURS  
BEFORE YOU DIG  
1-800-434-5555

**Parametrix, Inc.**  
5008 Lt. Washington Blvd. NE  
Kirkland, WA 98033  
Ph: (425) 822-8900  
www.parametrix.com

**REVISED**  
DATE: 11/17/09  
PROJECT: 291201W1  
SHEET: 291201W1-01

| NO. | DATE | BY | DESCRIPTION |
|-----|------|----|-------------|
|     |      |    |             |
|     |      |    |             |
|     |      |    |             |
|     |      |    |             |

| NO. | DATE | BY | DESCRIPTION |
|-----|------|----|-------------|
|     |      |    |             |
|     |      |    |             |
|     |      |    |             |
|     |      |    |             |
|     |      |    |             |

| NO. | DATE | BY | DESCRIPTION |
|-----|------|----|-------------|
|     |      |    |             |
|     |      |    |             |
|     |      |    |             |
|     |      |    |             |
|     |      |    |             |

**Port of Seattle**  
**SEA-TAC INTERNATIONAL AIRPORT**  
MILLER CREEK INSTREAM BUFFER ENHANCEMENT  
PROJECT NO. 291201W1  
SHEET NO. 291201W1-01

**AGENCY REVIEW**  
**NOT FOR CONSTRUCTION**

291201W1-01

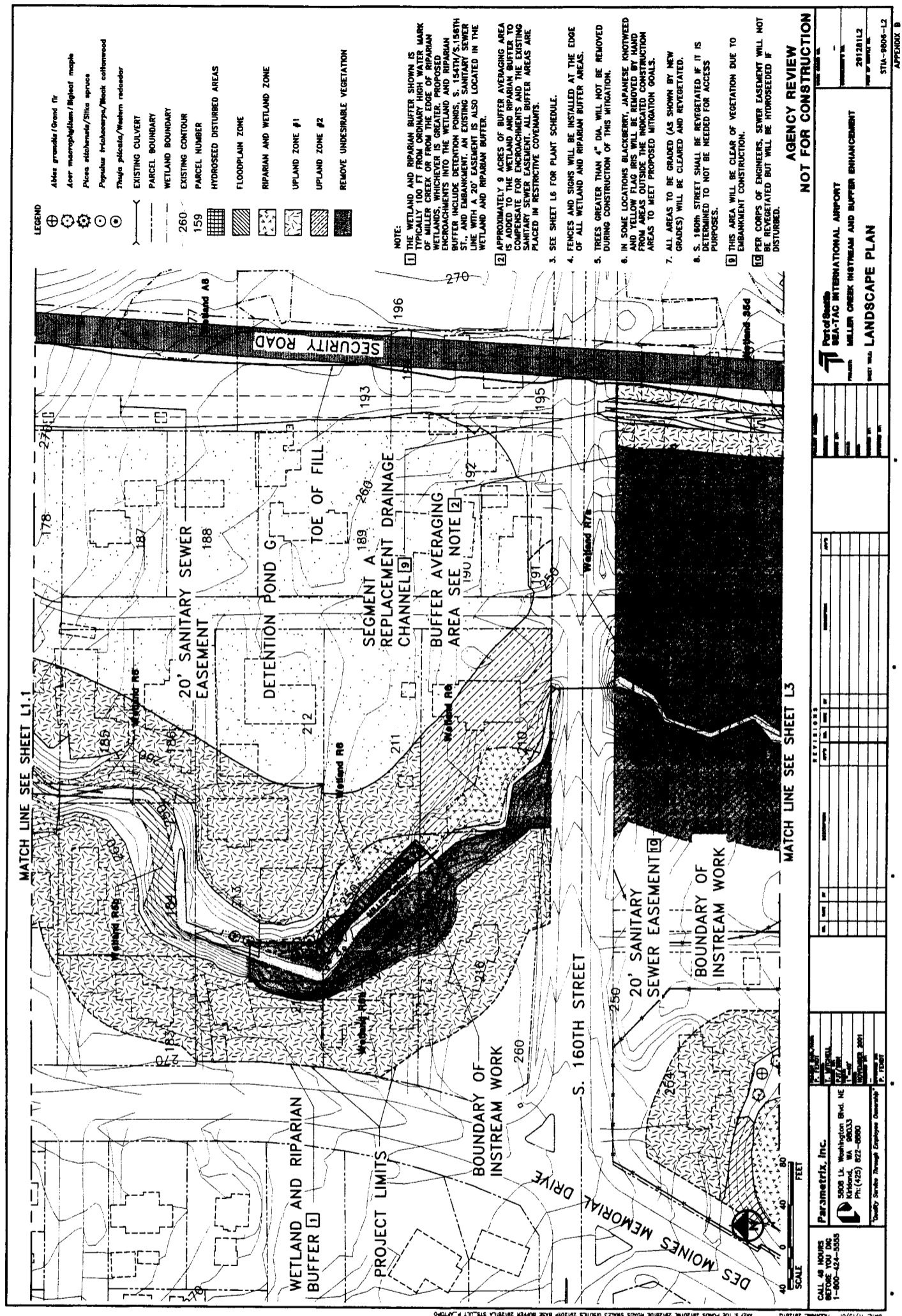
291201W1

291201W1

APPENDIX B  
STIA-8008-L1  
291201L1  
PORT OF SEATTLE WA

AR 049456





**LEGEND**

- ⊕ *Alnus graveolens / Grand fir*
- ⊙ *Acer macrophyllum / Bigleaf maple*
- ⊗ *Picea sitchensis / Sitka spruce*
- ⊖ *Populus trichocarpa / Black cottonwood*
- ⊘ *Thuja plicata / Western redcedar*
- EXISTING CULVERT
- PARCEL BOUNDARY
- WETLAND BOUNDARY
- EXISTING CONTOUR
- PARCEL NUMBER
- ▨ HYDROSEED DISTURBED AREAS
- ▩ FLOODPLAIN ZONE
- ▧ RIPARIAN AND WETLAND ZONE
- ▦ UPLAND ZONE #1
- ▥ UPLAND ZONE #2
- ▤ REMOVE UNDESIRABLE VEGETATION

**NOTE:**

1. THE WETLAND AND RIPARIAN BUFFER SHOWN IS SPECIALLY GOVT FROM ORDINARY HIGH WATER MARK (OHWM) AND IS TO BE MAINTAINED AS SUCH. RIPARIAN WETLANDS, WHICH EVER IS GREATER PROPOSED ENCROACHMENTS INTO THE WETLAND AND RIPARIAN BUFFER INCLUDE DETENTION PONDS, S. 154TH/S.158TH ST., AND EMBANKMENT. AN EXISTING SANITARY SEWER LINE WITH A 20' EASEMENT IS ALSO LOCATED IN THE WETLAND AND RIPARIAN BUFFER.
2. APPROXIMATELY 8 ACRES OF BUFFER AVERAGING AREA IS ADDED TO THE WETLAND BUFFER TO COMPENSATE FOR ENCROACHMENTS AND THE EXISTING SANITARY SEWER EASEMENT. ALL BUFFER AREAS ARE PLACED IN RESTRICTIVE COVENANTS.
3. SEE SHEET L6 FOR PLANT SCHEDULE.
4. FENCES AND SIGNS WILL BE INSTALLED AT THE EDGE OF ALL WETLAND AND RIPARIAN BUFFER AREAS.
5. TREES GREATER THAN 4" DIA. WILL NOT BE REMOVED DURING CONSTRUCTION OF THIS MITIGATION.
6. IN SOME LOCATIONS BLACKBERRY, JAPANESE KNOTWEED AND YELLOW FLAG IRIS WILL BE REMOVED BY HAND DURING CONSTRUCTION OF THIS MITIGATION. THESE AREAS TO MEET PROPOSED MITIGATION GOALS.
7. ALL AREAS TO BE GRADED (AS SHOWN BY NEW GRADES) WILL BE CLEARED AND REVEGETATED.
8. S. 160TH STREET SHALL BE REVEGETATED IF IT IS DETERMINED TO NOT BE NEEDED FOR ACCESS PURPOSES.
9. THIS AREA WILL BE CLEAR OF VEGETATION DUE TO EMBANKMENT CONSTRUCTION.
10. PER CORPS OF ENGINEERS, SEWER EASEMENT WILL NOT BE REVEGETATED BUT WILL BE HYDROSEED IF DISTURBED.

**AGENCY REVIEW**

**NOT FOR CONSTRUCTION**

Port of Seattle  
SEA-TAC INTERNATIONAL AIRPORT  
MILLER CREEK INSTREAM AND BUFFER ENHANCEMENT  
LANDSCAPE PLAN

|              |                               |
|--------------|-------------------------------|
| DATE:        | 2012.08.12                    |
| PROJECT:     | SEA-TAC INTERNATIONAL AIRPORT |
| SCALE:       | AS SHOWN                      |
| DESIGNED BY: |                               |
| CHECKED BY:  |                               |
| APPROVED BY: |                               |

|     |      |    |           |
|-----|------|----|-----------|
| NO. | DATE | BY | REVISIONS |
|     |      |    |           |
|     |      |    |           |
|     |      |    |           |

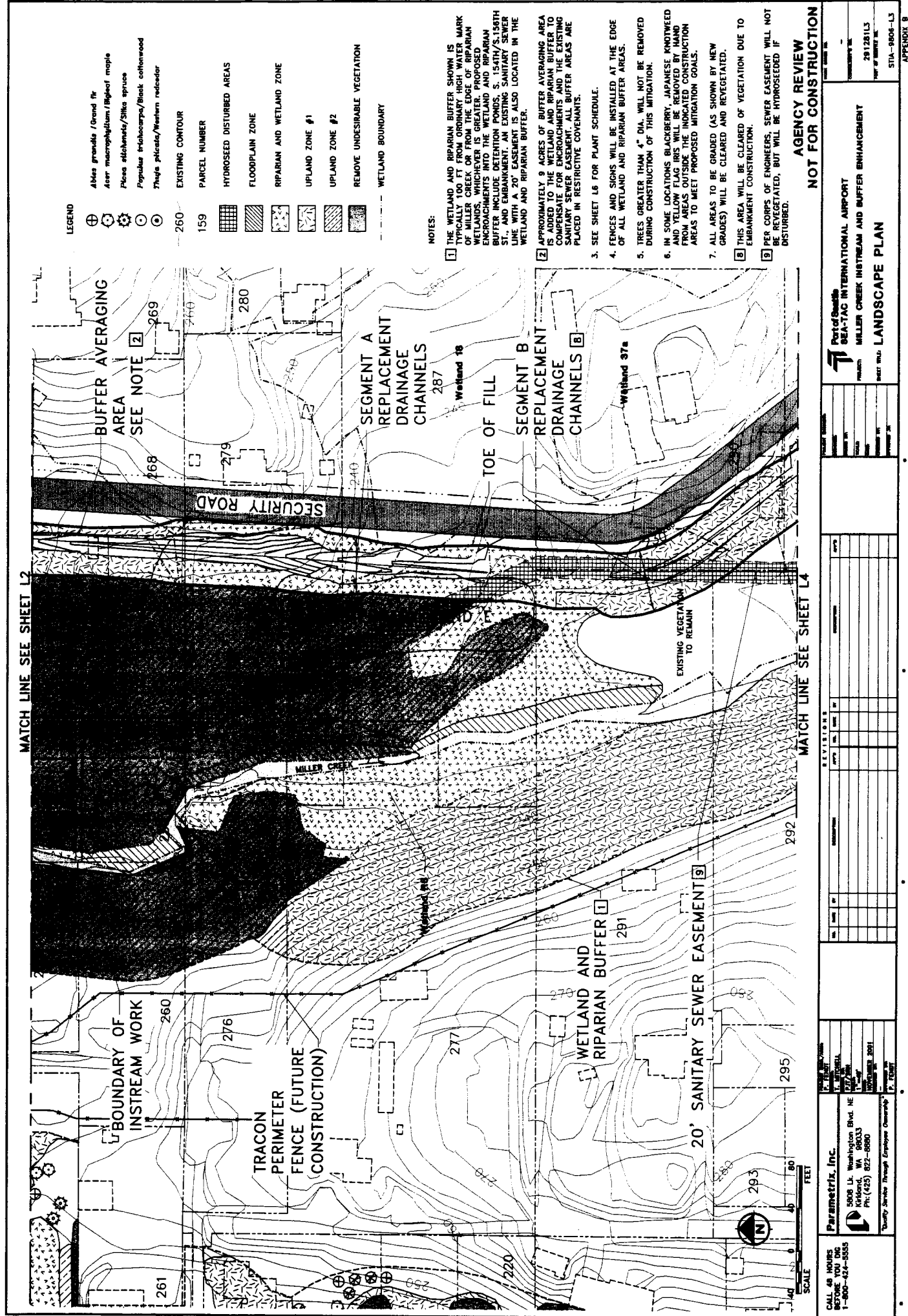
|              |                               |
|--------------|-------------------------------|
| DATE:        | 2012.08.12                    |
| PROJECT:     | SEA-TAC INTERNATIONAL AIRPORT |
| SCALE:       | AS SHOWN                      |
| DESIGNED BY: |                               |
| CHECKED BY:  |                               |
| APPROVED BY: |                               |

|              |                               |
|--------------|-------------------------------|
| DATE:        | 2012.08.12                    |
| PROJECT:     | SEA-TAC INTERNATIONAL AIRPORT |
| SCALE:       | AS SHOWN                      |
| DESIGNED BY: |                               |
| CHECKED BY:  |                               |
| APPROVED BY: |                               |

**Paramatrix, Inc.**  
 5808 Lt. Washington Blvd. NE  
 Kirkland, WA 98033  
 Ph: (425) 622-6860  
 Email: info@paramatrix.com  
 Website: www.paramatrix.com

CALL 48 HOURS BEFORE YOU DIG  
 1-800-424-5555

AR 049458



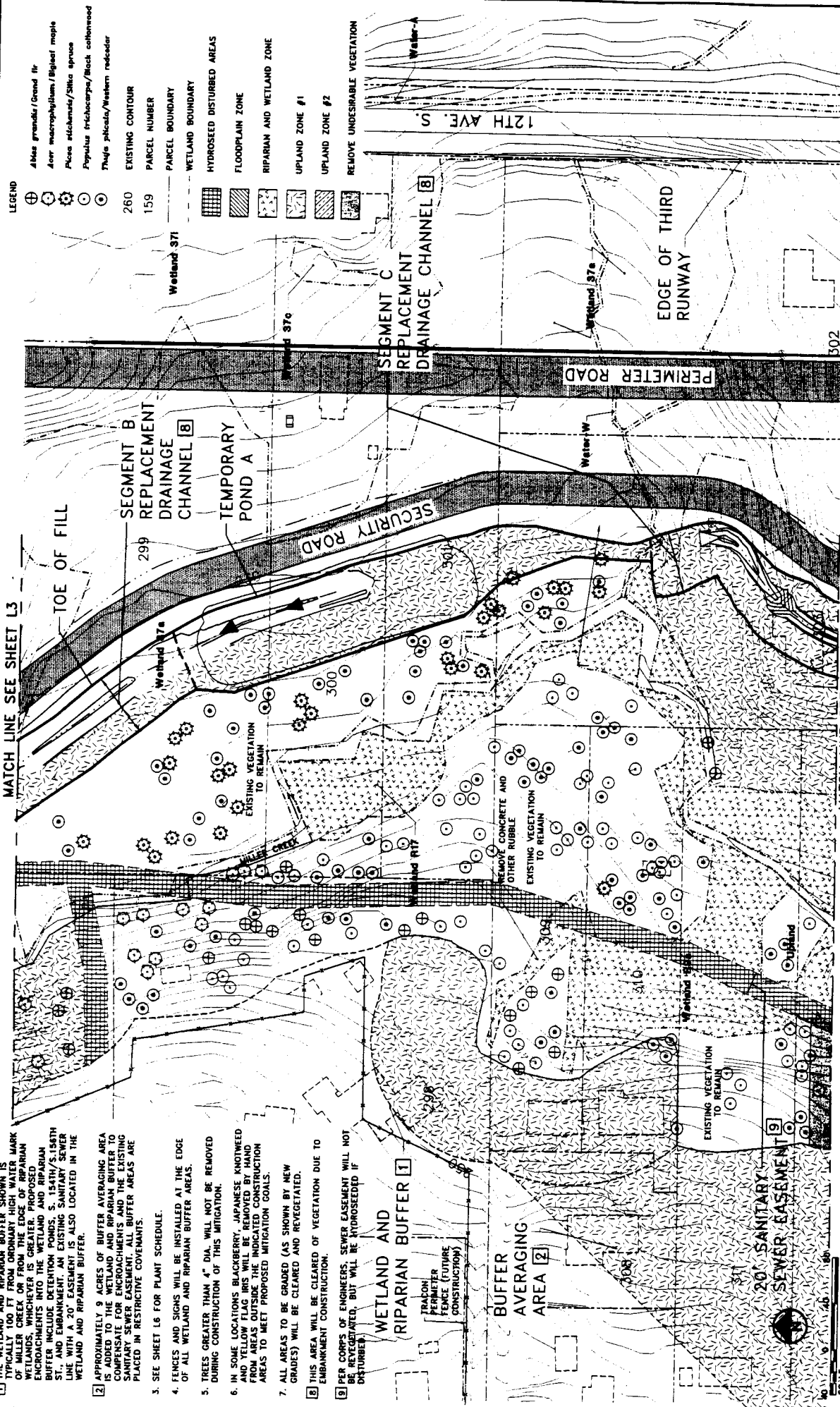
AR 049459

**NOTES:**

- [1] THE WETLAND AND RIPARIAN BUFFER SHOWN IS TYPICALLY 100 FT FROM ORDINARY HIGH WATER MARK OF MILLER CREEK OR FROM THE EDGE OF RIPARIAN WETLANDS, WHICHEVER IS GREATER. PROPOSED ENCROACHMENTS INTO THE WETLAND AND RIPARIAN BUFFER INCLUDE DETENTION PONDS, S. 154TH/S-156TH STREET EASEMENT, AN EXISTING SANITARY SEWER LINE WITH 20' EASEMENT, AND ALSO LOCATED IN THE WETLAND AND RIPARIAN BUFFER.
- [2] APPROXIMATELY 9 ACRES OF BUFFER AVERAGING AREA IS ADDED TO THE WETLAND AND RIPARIAN BUFFER TO COMPENSATE FOR ENCROACHMENTS AND THE EXISTING SANITARY SEWER EASEMENT. ALL BUFFER AREAS ARE PLACED IN RESTRICTIVE COVENANTS.
3. SEE SHEET L6 FOR PLANT SCHEDULE.
4. FENCES AND SIGNS WILL BE INSTALLED AT THE EDGE OF ALL WETLAND AND RIPARIAN BUFFER AREAS.
5. TREES GREATER THAN 4" DIA. WILL NOT BE REMOVED DURING CONSTRUCTION OF THIS MITIGATION.
6. IN SOME LOCATIONS BLACKBERRY, JAPANESE KNOTWEED AND YELLOW FLAG IRIS WILL BE REMOVED BY HAND FROM AREAS OUTSIDE THE INDICATED CONSTRUCTION AREAS TO MEET PROPOSED MITIGATION GOALS.
7. ALL AREAS TO BE GRADED (AS SHOWN BY NEW GRADES) WILL BE CLEARED AND REVEGETATED.
- [8] THIS AREA WILL BE CLEARED OF VEGETATION DUE TO EMBANKMENT CONSTRUCTION.
- [9] PER CORPUS OF ENGINEERS, SEWER EASEMENT WILL NOT BE RECONSTRUCTED, BUT WILL BE ATROPHIED IF DISTURBED.

MATCH LINE SEE SHEET L3

MATCH LINE SEE SHEET L5



- LEGEND**
- Abies grandis/Grand fir
  - Acer macrophyllum/Bigleaf maple
  - Phase sitchensis/Sitka spruce
  - Populus trichocarpa/Black cottonwood
  - Thuja plicata/Western redcedar
  - 260
  - 159
  - EXISTING CONTOUR
  - PARCEL NUMBER
  - WETLAND BOUNDARY
  - HYDROSEED DISTURBED AREAS
  - FLOODPLAIN ZONE
  - RIPARIAN AND WETLAND ZONE
  - UPLAND ZONE #1
  - UPLAND ZONE #2
  - REMOVE UNDESIRABLE VEGETATION

**NOT FOR CONSTRUCTION**

| NO. | DESCRIPTION | DATE | BY | CHECKED | SCALE |
|-----|-------------|------|----|---------|-------|
|     |             |      |    |         |       |
|     |             |      |    |         |       |
|     |             |      |    |         |       |
|     |             |      |    |         |       |
|     |             |      |    |         |       |

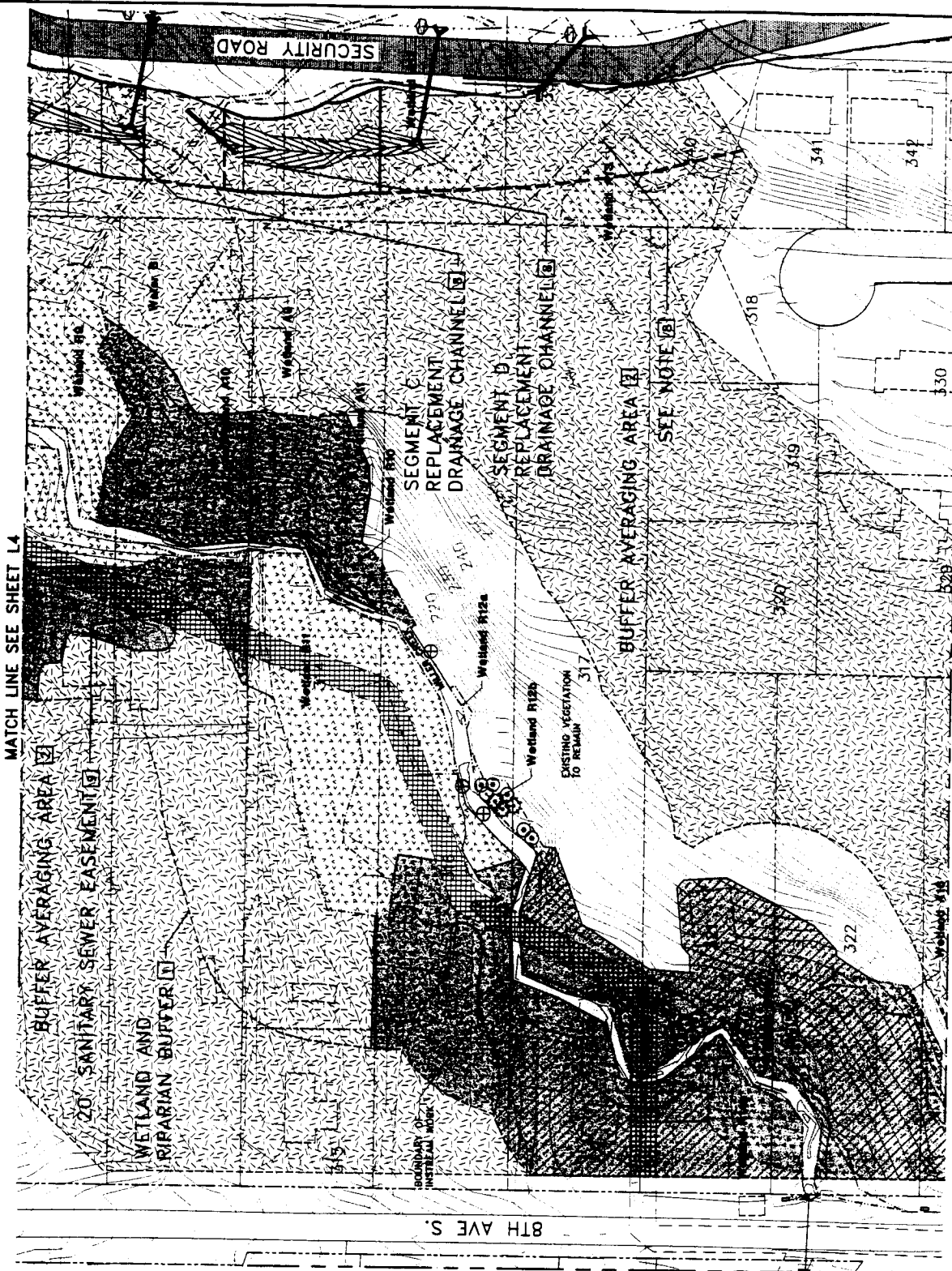
  

|                                                                                                     |                                                                                               |
|-----------------------------------------------------------------------------------------------------|-----------------------------------------------------------------------------------------------|
| <b>Parametrix, Inc.</b><br>5808 Lk. Washington Blvd. NE<br>Kirkland, WA 98033<br>Ph: (425) 822-8800 | <b>Parametrix</b><br>5808 Lk. Washington Blvd. NE<br>Kirkland, WA 98033<br>Ph: (425) 822-8800 |
|-----------------------------------------------------------------------------------------------------|-----------------------------------------------------------------------------------------------|

DATE: 11/17/01 PLANS: 29121014 PHOTOS: 29121014 MOBS: 29121014 RDS: 29121014 S: 29121014 BUFFER PLAN: 29121014





- NOTES:**
1. THE WETLAND AND RIPARIAN BUFFER SHOWN IS TYPICALLY 100 FT FROM ORDINARY HIGH WATER MARK OF MILLER CREEK OR FROM THE EDGE OF RIPARIAN WETLANDS, WHICHEVER IS GREATER. PROPOSED BUFFER INCLUDES SETBACK FROM EXISTING ST. AND EMBANKMENT. SANITARY SEWER LINE WITH A 20' EASEMENT IS ALSO LOCATED IN THE WETLAND AND RIPARIAN BUFFER.
  2. APPROXIMATELY 9 ACRES OF BUFFER AVERAGING AREA IS ADDED TO THE WETLAND AND RIPARIAN BUFFER TO COMPENSATE FOR ENCROACHMENTS AND THE EXISTING SANITARY SEWER EASEMENT. BUFFER AREAS ARE PLACED IN RESTRICTIVE COVENANTS.
  3. SEE SHEET L6 FOR PLANT SCHEDULE.
  4. FENCES AND SIGNS WILL BE INSTALLED AT THE EDGE OF ALL WETLAND AND RIPARIAN BUFFER AREAS.
  5. TREES GREATER THAN 4" DIA. WILL NOT BE REMOVED DURING CONSTRUCTION OF THIS MITIGATION.
  6. IN SOME LOCATIONS BLACKBERRY, JAPANESE KNOTWEED AND YELLOW FLAG IRIS WILL BE REMOVED BY HAND FROM AREAS OUTSIDE THE INDICATED CONSTRUCTION AREAS TO MEET PROPOSED MITIGATION GOALS.
  7. ALL AREAS TO BE GRADED (AS SHOWN BY NEW GRADES) WILL BE CLEARED AND REVEGETATED.
  8. THIS AREA WILL BE CLEARED OF VEGETATION AS A RESULT OF EMBANKMENT CONSTRUCTION.
  9. PER CORPS OF ENGINEERS, SEWER EASEMENT WILL NOT BE REVEGETATED, BUT WILL BE HYDROSEEDED IF DISTURBED.

**LEGEND**

- Alnus graveolens / Grand fir
- Acer macrophyllum / Bigleaf maple
- Picea sitchensis / Sitka spruce
- Populus trichocarpa / Black cottonwood
- Thuja plicata / Western redcedar

EXISTING CULVERT

260 EXISTING CONTOUR

159 PARCEL NUMBER

PARCEL BOUNDARY

WETLAND BOUNDARY

WETLAND

HYDROSEED DISTURBED AREAS

FLOODPLAIN ZONE

RIPARIAN AND WETLAND ZONE

UPLAND ZONE #1

UPLAND ZONE #2

REMOVE UNDESIRABLE VEGETATION



MATCH LINE SEE SHEET L4

MATCH LINE SEE SHEET L5.1

MATCH LINE SEE SHEET L5.1

BTH AVE S

SECURITY ROAD

Wetland #1

Wetland #2

Wetland #3

Wetland #4

Wetland #5

Wetland #6

Wetland #7

Wetland #8

Wetland #9

Wetland #10

Wetland #11

Wetland #12

Wetland #13

Wetland #14

Wetland #15

Wetland #16

Wetland #17

Wetland #18

Wetland #19

Wetland #20

Wetland #21

Wetland #22

Wetland #23

Wetland #24

Wetland #25

Wetland #26

Wetland #27

Wetland #28

Wetland #29

Wetland #30

Wetland #31

Wetland #32

Wetland #33

Wetland #34

Wetland #35

Wetland #36

Wetland #37

Wetland #38

Wetland #39

Wetland #40

317

318

319

320

321

322

330

341

342

EXISTING VEGETATION TO REMAIN

SEE NOTE 8

AGENCY REVIEW

NOT FOR CONSTRUCTION

Parametrix, Inc.

5808 Lk. Washington Blvd. NE  
 Redmond, WA 98033  
 Ph: (425) 872-8800

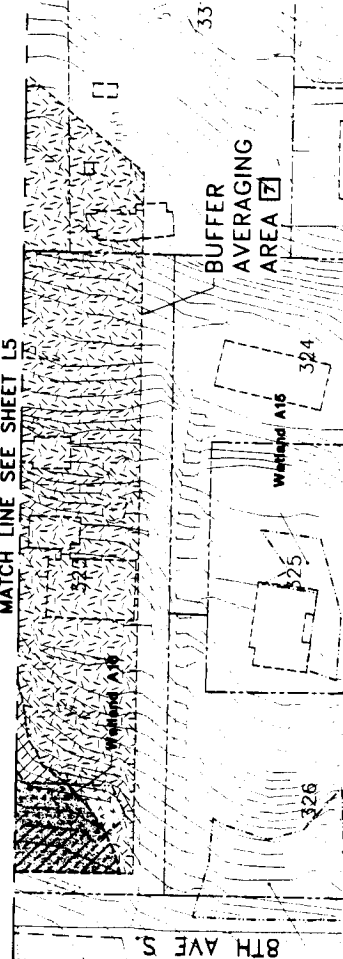
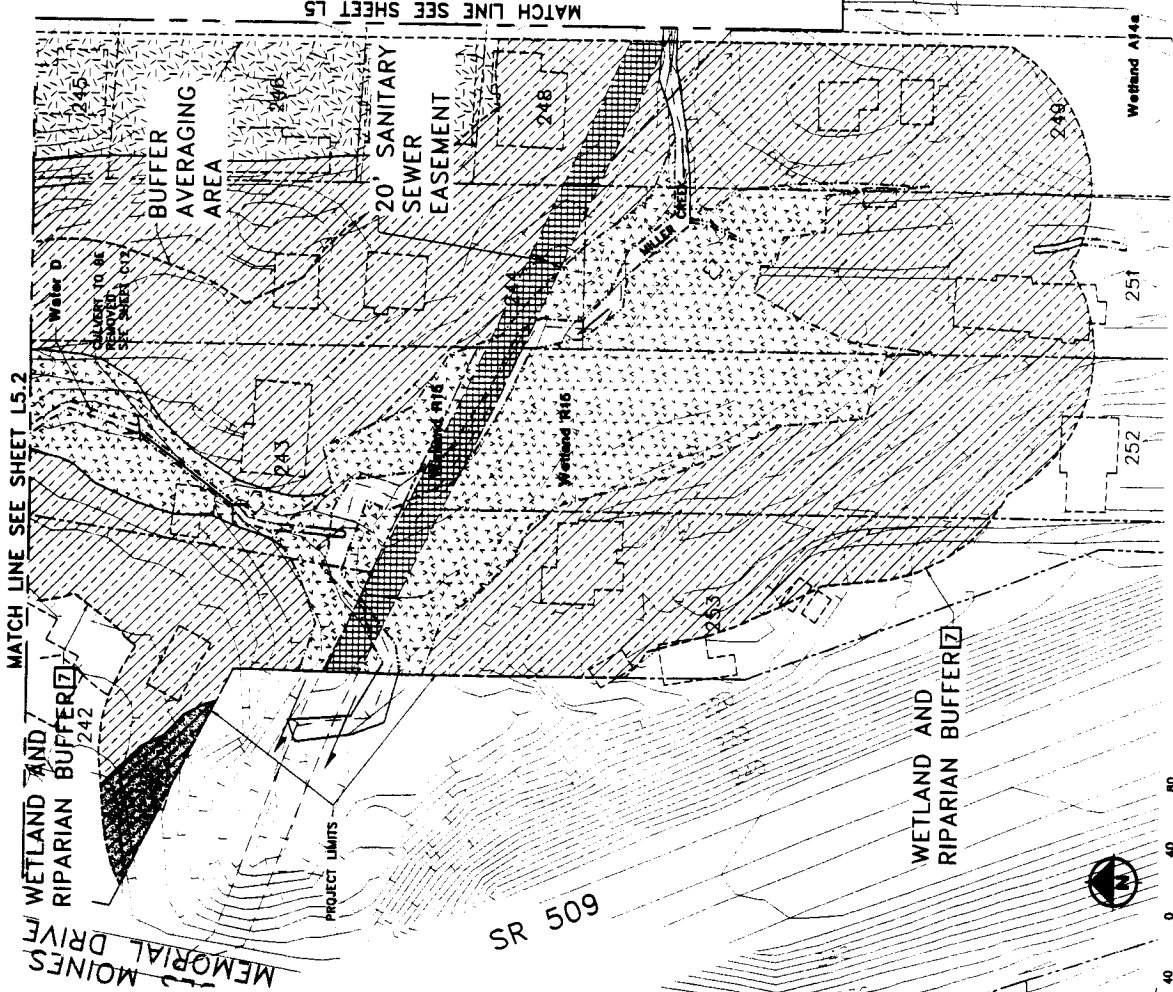
DATE: 11/13/07, PLAN: 291281L5  
 SHEET: 291281L5

APPENDIX B

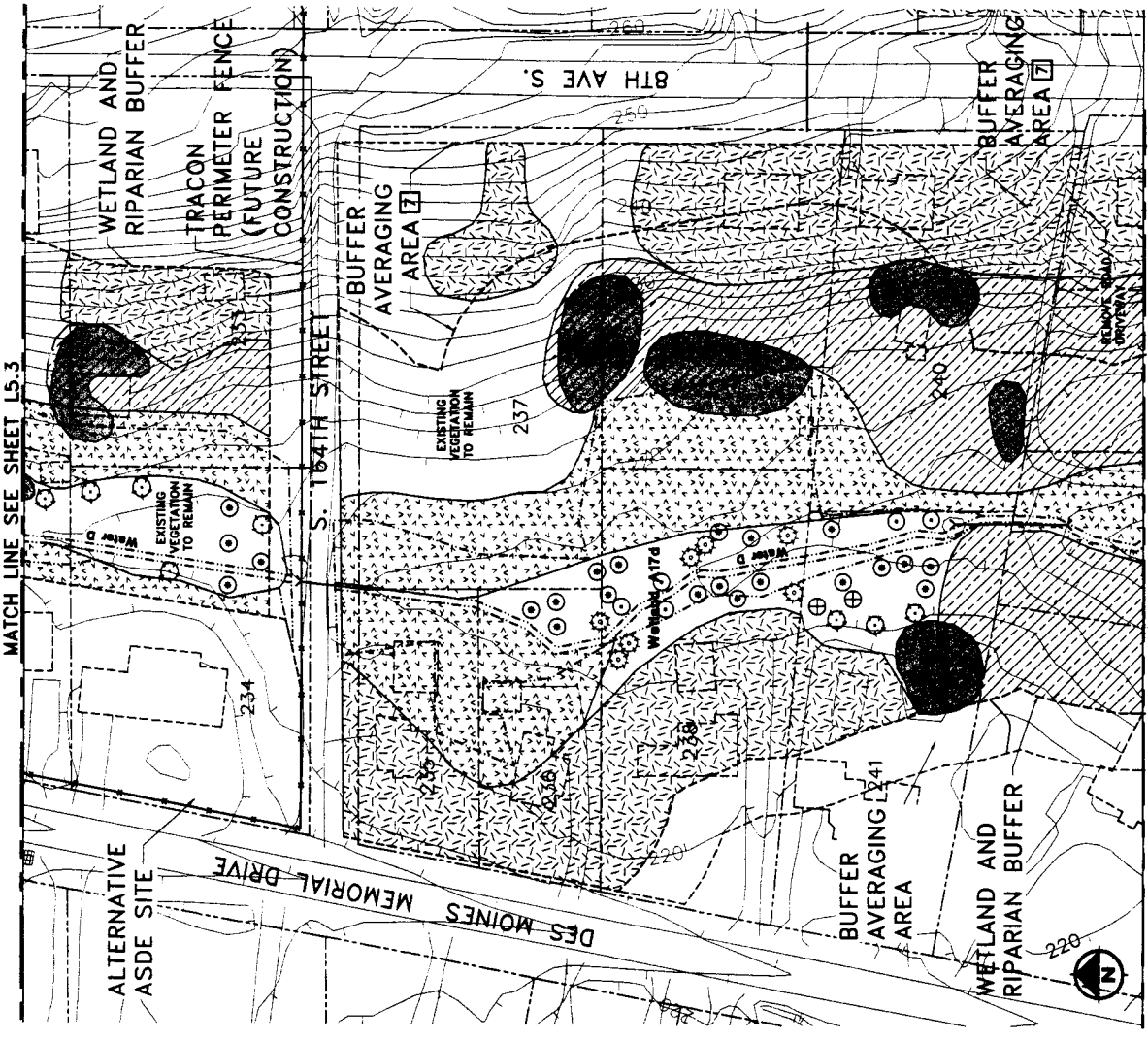
AR 049461

- NOTES:
1. SEE SHEET L6 FOR PLANT SCHEDULE.
  2. FENCES AND SIGNS WILL BE INSTALLED AT THE EDGE OF ALL WETLAND AND RIPARIAN BUFFER AREAS.
  3. AREAS WITHOUT A PLANTING HATCH DO NOT REQUIRE SHRUB OR TREE PLANTING TO MEET PROPOSED MITIGATION GOALS.
  4. TREES GREATER THAN 4" DIA. WILL NOT BE REMOVED DURING CONSTRUCTION OF THIS MITIGATION.
  5. IN SOME LOCATIONS, BLACKBERRY, JAPANESE KNOTWEED AND COMMON NODDY BUSH WILL BE REMOVED BY HAND FROM AREAS OUTSIDE THE INDICATED CONSTRUCTION AREAS TO MEET PROPOSED MITIGATION GOALS.
  6. 8TH AVENUE S. SHALL BE REVEGETATED IF IT IS DETERMINED TO NOT BE NEEDED FOR ACCESS PURPOSES.
  7. APPROXIMATELY 9 ACRES OF BUFFER AVERAGING AREA IS ADDED TO THE WETLAND AND RIPARIAN BUFFER TO COMPENSATE FOR ENCROACHMENTS AND THE EXISTING SANITARY SEWER EASEMENT. ALL BUFFER AREAS ARE PLACED IN RESTRICTIVE COVENANTS.
  8. PER CORPS OF ENGINEERS, SEWER EASEMENT WILL NOT BE REVEGETATED, BUT WILL BE HYDROSEEDED IF DISTURBED.

- LEGEND:
- HYDROSEED DISTURBED AREAS
  - FLOODPLAIN ZONE
  - RIPARIAN AND WETLAND ZONE
  - UPLAND ZONE #1
  - UPLAND ZONE #2
  - REMOVE UNDESIRABLE VEGETATION
  - EXISTING CULVERT
  - 260 EXISTING CONTOUR
  - 159 PARCEL NUMBER
  - PARCEL BOUNDARY
  - WETLAND BOUNDARY



|                                                                                                                                                      |                                                                                                                                                                                |                                                                                            |                                       |
|------------------------------------------------------------------------------------------------------------------------------------------------------|--------------------------------------------------------------------------------------------------------------------------------------------------------------------------------|--------------------------------------------------------------------------------------------|---------------------------------------|
| CALL US NOW<br>800-424-5555<br>5008 Lt. Washington Blvd. NE<br>Redmond, WA 98033<br>PH: (425) 822-6800<br>Quality Service Through Employee Ownership | PROJECT NO. _____<br>SHEET NO. _____ OF _____<br>DATE: 11/13/07<br>DRAWN BY: J. WATSON<br>CHECKED BY: J. WATSON<br>PROJECT TITLE: MILLER CREEK INSTREAM AND BUFFER ENHANCEMENT | PROJECT TITLE: MILLER CREEK INSTREAM AND BUFFER ENHANCEMENT<br>SHEET TITLE: LANDSCAPE PLAN | AGENCY REVIEW<br>NOT FOR CONSTRUCTION |
|                                                                                                                                                      | PROJECT NO. _____<br>SHEET NO. _____ OF _____<br>DATE: 11/13/07<br>DRAWN BY: J. WATSON<br>CHECKED BY: J. WATSON<br>PROJECT TITLE: MILLER CREEK INSTREAM AND BUFFER ENHANCEMENT | PROJECT TITLE: MILLER CREEK INSTREAM AND BUFFER ENHANCEMENT<br>SHEET TITLE: LANDSCAPE PLAN | AGENCY REVIEW<br>NOT FOR CONSTRUCTION |



**NOTES:**

1. SEE SHEET L8 FOR PLANT SCHEDULE.
2. FENCES AND SIGNS WILL BE INSTALLED AT THE EDGE OF ALL WETLAND AND RIPARIAN BUFFER AREAS.
3. AREAS WITHOUT A PLANTING HATCH DO NOT REQUIRE SHRUB OR TREE PLANTING TO MEET PROPOSED MITIGATION GOALS.
4. TREES GREATER THAN 4" DIA. WILL NOT BE REMOVED DURING CONSTRUCTION OF THIS MITIGATION.
5. IN SOME LOCATIONS BLACKBERRY, JAPANESE KNOTWEED AND YELLOW FLAG IRIS WILL BE REMOVED BY HAND FROM AREAS OUTSIDE THE INDICATED CONSTRUCTION AREAS TO MEET PROPOSED MITIGATION GOALS.
6. 8TH AVE S. SHALL BE REVEGETATED IF IT IS DETERMINED TO NOT BE NEEDED FOR ACCESS PURPOSES.

**7** APPROXIMATELY 9 ACRES OF BUFFER AVERAGING IS ADDED TO THE WETLAND AND RIPARIAN BUFFER TO COMPENSATE FOR ENCROACHMENTS AND THE EXISTING SANITARY SEWER EASEMENT. ALL BUFFER AREAS ARE PLACED IN RESTRICTIVE COVENANTS.

**LEGEND**

- ⊕ *Abies grandis* / Grand fir
- ⊗ *Acer macrophyllum* / Bigleaf maple
- ⊙ *Phaseolus* / Silica spruce
- ⊖ *Populus trichocarpa* / Black cottonwood
- ⊘ *Thuja plicata* / Western redcedar
- ⊗ *Pseudotsuga menziesii* / Douglas Fir

- [Grid Pattern] HYDROSEED DISTURBED AREAS
- [Diagonal Lines] FLOODPLAIN ZONE
- [Cross-hatch] RIPARIAN AND WETLAND ZONE
- [Stippled] UPLAND ZONE #1
- [Dotted] UPLAND ZONE #2
- [Dark Stippled] REMOVE UNDESIRABLE VEGETATION
- [Line with Arrow] EXISTING CULVERT
- [Dashed Line] EXISTING CONTOUR 260
- [Dashed Line] EXISTING CONTOUR 159
- [Dashed Line] PARCEL BOUNDARY
- [Dotted Line] WETLAND BOUNDARY



MATCH LINE SEE SHEET L5.1

MATCH LINE SEE SHEET L5.3

**AGENCY REVIEW  
NOT FOR CONSTRUCTION**

**Port of Seattle**  
SEA-TAC INTERNATIONAL AIRPORT  
MILLER CREEK INSTREAM AND BUFFER ENHANCEMENT  
PROJECT NO. 20128115.2  
SHEET NO. L5  
LANDSCAPE PLAN

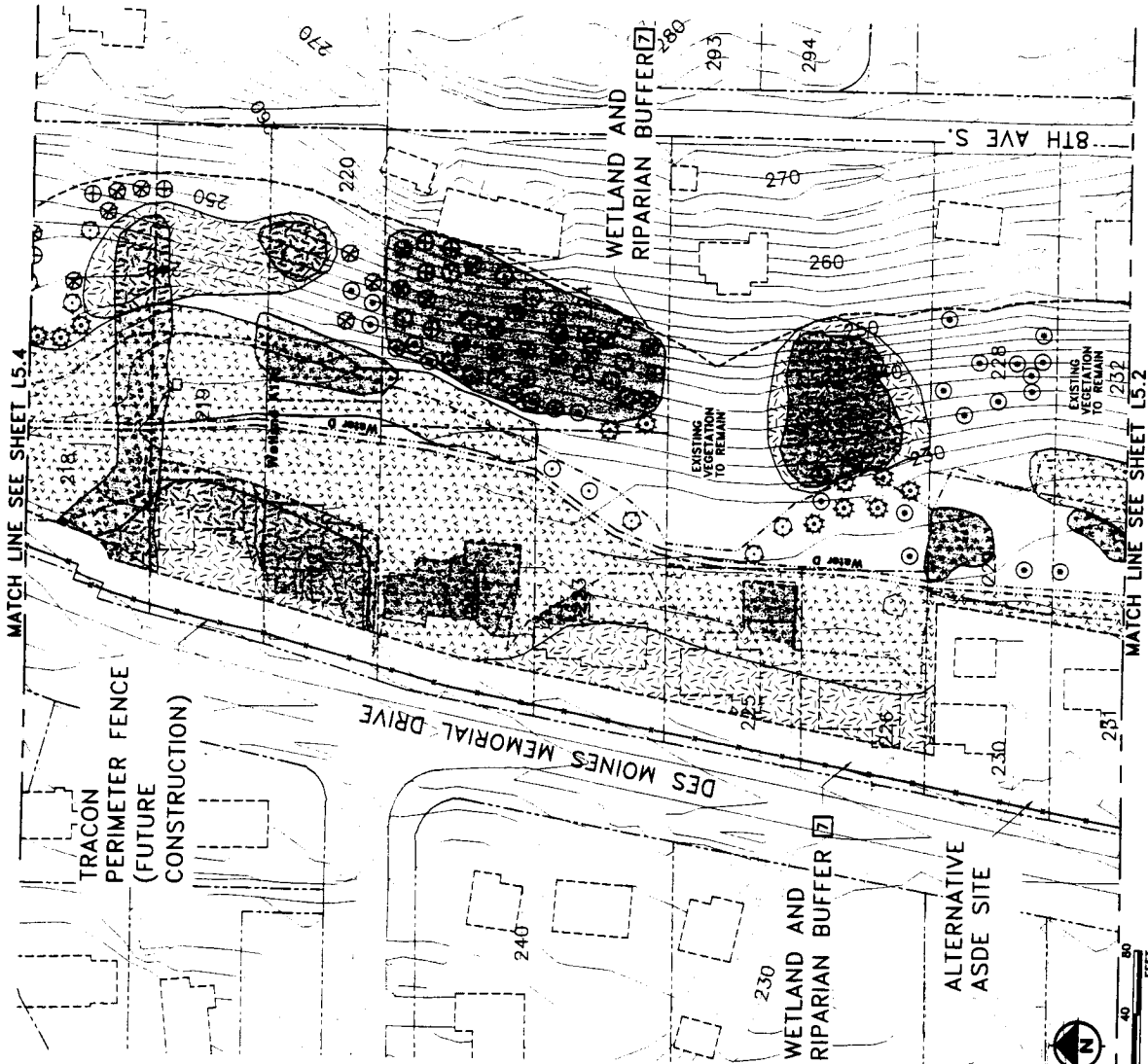
DATE: 11/17/09  
FILENAME: 20128115.2  
SCALE: 1"=40'  
DATE: 11/17/09  
FILENAME: 20128115.2  
SCALE: 1"=40'  
DATE: 11/17/09  
FILENAME: 20128115.2  
SCALE: 1"=40'

AR 049463

**NOTES:**

- SEE SHEET L6 FOR PLANT SCHEDULE.
- FENCES AND SIGNS WILL BE INSTALLED AT THE EDGE OF ALL WETLAND AND RIPARIAN BUFFER AREAS.
- AREAS WITHOUT A PLANTING HATCH DO NOT REQUIRE SHRUB OR TREE PLANTING TO MEET PROPOSED MITIGATION GOALS.
- TREES GREATER THAN 4" DIA. WILL NOT BE REMOVED DURING CONSTRUCTION OF THIS MITIGATION.
- IN SOME LOCATIONS BLACKBERRY, JAPANESE KNOTWEED AND YELLOW FLAG IRIS WILL BE REMOVED BY HAND IN AREAS OUTSIDE THE INDICATED CONSTRUCTION AREAS TO MEET PROPOSED MITIGATION GOALS.
- 164TH STREET SHALL BE REVEGETATED IF IT IS DETERMINED TO NOT BE NEEDED FOR ACCESS PURPOSES.
- APPROXIMATELY 9 ACRES OF BUFFER AVERAGING AREA IS ADDED TO THE WETLAND AND RIPARIAN BUFFER TO COMPENSATE FOR ENCROACHMENTS AND THE EXISTING SANITARY SEWER EASEMENT. ALL BUFFER AREAS ARE PLACED IN RESTRICTIVE COVENANTS.

- LEGEND**
- ⊕ *Abies grandis* / Grand fir
  - ⊙ *Acer macrophyllum* / Bigleaf maple
  - ⊗ *Platanus alatanensis* / Sika spruce
  - ⊖ *Populus trichocarpa* / Black cottonwood
  - ⊘ *Thuja plicata* / Western redcedar
  - ⊙ *Pseudotsuga mansueti* / Douglas fir
- HYDROSEED DISTURBED AREAS
  - FLOODPLAIN ZONE
  - RIPARIAN AND WETLAND ZONE
  - UPLAND ZONE #1
  - UPLAND ZONE #2
  - REMOVE UNDESIRABLE VEGETATION
  - 260 EXISTING CONTOUR
  - 159 PARCEL NUMBER
  - PARCEL BOUNDARY
  - - - WETLAND BOUNDARY



MATCH LINE SEE SHEET L5.4

MATCH LINE SEE SHEET L5.2

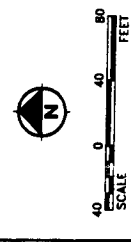
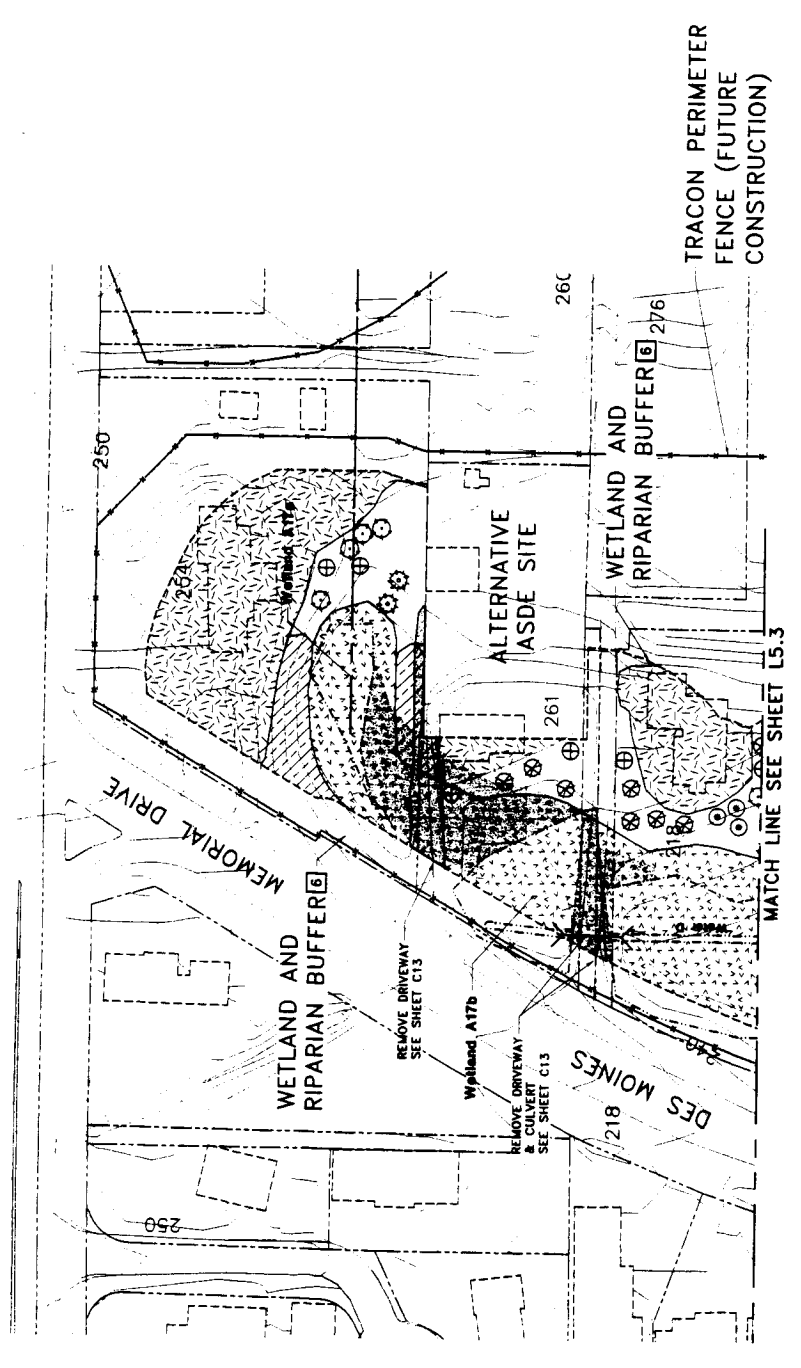
**AGENCY REVIEW  
NOT FOR CONSTRUCTION**

|                                                                                                                                                                       |                                                                                                                                    |                                                                            |                             |
|-----------------------------------------------------------------------------------------------------------------------------------------------------------------------|------------------------------------------------------------------------------------------------------------------------------------|----------------------------------------------------------------------------|-----------------------------|
| <br><b>Parametrix, Inc.</b><br>5908 L.A. Washington Blvd. NE<br>Bellevue, WA 98003<br>Ph: (425) 822-8800<br><small>Quality Service Through Employee Ownership</small> | Project: <b>SEA-TAC INTERNATIONAL AIRPORT<br/>MILLER CREEK INSTREAM AND BUFFER ENHANCEMENT</b><br>Sheet No.: <b>LANDSCAPE PLAN</b> | Revision: _____<br>Date: _____<br>By: _____<br>Check: _____<br>Appr: _____ | STA-8806-L5.3<br>APPENDIX B |
|-----------------------------------------------------------------------------------------------------------------------------------------------------------------------|------------------------------------------------------------------------------------------------------------------------------------|----------------------------------------------------------------------------|-----------------------------|

AR 049464

- NOTES:**
- SEE SHEET L6 FOR PLANT SCHEDULE.
  - FENCES AND SIGNS WILL BE INSTALLED AT THE EDGE OF ALL WETLAND AND RIPARIAN BUFFER AREAS.
  - AREAS WITHOUT A PLANTING MATCH DO NOT REQUIRE SHRUB OR TREE PLANTING TO MEET PROPOSED MITIGATION GOALS.
  - TREES GREATER THAN 4" DIA. WILL NOT BE REMOVED DURING CONSTRUCTION OF THIS MITIGATION.
  - IN SOME LOCATIONS BLACKBERRY, JAPANESE KNOTWEED AND OTHER WEEDS WILL BE REMOVED BY HAND FROM AREAS OUTSIDE THE WETLAND CONSTRUCTION AREAS TO MEET PROPOSED MITIGATION GOALS.
  - APPROXIMATELY 9 ACRES OF BUFFER AVERAGING AREA IS ADDED TO THE WETLAND AND RIPARIAN BUFFER TO COMPENSATE FOR ENCROACHMENTS AND THE EXISTING RESTRICTIVE COVENANTS. ALL BUFFER AREAS ARE PLACED IN RESTRICTIVE COVENANTS.

- LEGEND**
- Abies grandis / Grand fir
  - Acer macrophyllum / Bigleaf maple
  - Picea sitchensis / Sitka spruce
  - Populus trichocarpa / Black cottonwood
  - Thuja plicata / Western redcedar
  - Pseudotsuga mansueti / Douglas Fir
  - HYDROSEED DISTURBED AREAS
  - FLOODPLAIN ZONE
  - RIPARIAN AND WETLAND ZONE
  - UPLAND ZONE #1
  - UPLAND ZONE #2
  - REMOVE UNDESIRABLE VEGETATION
  - EXISTING CULVERT
  - EXISTING CONTOUR
  - PARCEL NUMBER
  - PARCEL BOUNDARY
  - WETLAND BOUNDARY



| <b>AGENCY REVIEW<br/>NOT FOR CONSTRUCTION</b>                                                                                                                                                        |                                                                                                                                                                                                                                                                                                                                                                                  |             |     |      |             |  |  |  |  |  |  |  |  |  |  |  |
|------------------------------------------------------------------------------------------------------------------------------------------------------------------------------------------------------|----------------------------------------------------------------------------------------------------------------------------------------------------------------------------------------------------------------------------------------------------------------------------------------------------------------------------------------------------------------------------------|-------------|-----|------|-------------|--|--|--|--|--|--|--|--|--|--|--|
| <p><b>CALL 48 HOURS BEFORE WORK</b></p> <p><b>Paramatrix, Inc.</b><br/>5808 Lk. Washington Blvd. NE<br/>Redmond, WA 98033<br/>PH: (425) 822-8880<br/>Quality Services Through Employee Ownership</p> | <p><b>REVISIONS</b></p> <table border="1" style="width: 100%; border-collapse: collapse;"> <thead> <tr> <th>NO.</th> <th>DATE</th> <th>DESCRIPTION</th> </tr> </thead> <tbody> <tr> <td> </td> <td> </td> <td> </td> </tr> <tr> <td> </td> <td> </td> <td> </td> </tr> <tr> <td> </td> <td> </td> <td> </td> </tr> <tr> <td> </td> <td> </td> <td> </td> </tr> </tbody> </table> |             | NO. | DATE | DESCRIPTION |  |  |  |  |  |  |  |  |  |  |  |
| NO.                                                                                                                                                                                                  | DATE                                                                                                                                                                                                                                                                                                                                                                             | DESCRIPTION |     |      |             |  |  |  |  |  |  |  |  |  |  |  |
|                                                                                                                                                                                                      |                                                                                                                                                                                                                                                                                                                                                                                  |             |     |      |             |  |  |  |  |  |  |  |  |  |  |  |
|                                                                                                                                                                                                      |                                                                                                                                                                                                                                                                                                                                                                                  |             |     |      |             |  |  |  |  |  |  |  |  |  |  |  |
|                                                                                                                                                                                                      |                                                                                                                                                                                                                                                                                                                                                                                  |             |     |      |             |  |  |  |  |  |  |  |  |  |  |  |
|                                                                                                                                                                                                      |                                                                                                                                                                                                                                                                                                                                                                                  |             |     |      |             |  |  |  |  |  |  |  |  |  |  |  |



**MILLER CREEK BUFFER ENHANCEMENT PLANT SCHEDULE**

| Symbol                                                            | Botanical Name / Common Name                  | Size         | Quantity | Condition / Remarks                                             |
|-------------------------------------------------------------------|-----------------------------------------------|--------------|----------|-----------------------------------------------------------------|
| 1                                                                 | <i>Aster grandiflorus</i> / Bigleaf aster     | 18" - 22" H. | 27       | Container or B&B. Rooting to sides and bottom of can or burlap. |
| 2                                                                 | <i>Acer macrophyllum</i> / Bigleaf maple      | 18" - 22" H. | 18       | -                                                               |
| 3                                                                 | <i>Picea sitchensis</i> / Sitka spruce *      | 18" - 22" H. | 54       | -                                                               |
| 4                                                                 | <i>Populus trichocarpa</i> / Black cottonwood | 18" - 22" H. | 77       | -                                                               |
| 5                                                                 | <i>Thuja plicata</i> / Western redcedar *     | 18" - 22" H. | 142      | -                                                               |
| 6                                                                 | <i>Pseudotsuga menziesii</i> / Douglas fir    | 18" - 22" H. |          | -                                                               |
| <b>FLOODPLAIN ZONE - Single Species</b>                           |                                               |              |          |                                                                 |
| Density (Plants Per Acre)                                         |                                               |              |          |                                                                 |
| Group of 3 to 7                                                   |                                               |              |          |                                                                 |
| 280                                                               |                                               |              |          |                                                                 |
| Group of 2 to 7                                                   |                                               |              |          |                                                                 |
| 2,100                                                             |                                               |              |          |                                                                 |
| <b>TREES</b>                                                      |                                               |              |          |                                                                 |
| <i>Alnus rubra</i> / Red alder                                    |                                               |              |          |                                                                 |
| <i>Populus trichocarpa</i> / Black cottonwood                     |                                               |              |          |                                                                 |
| <b>SHRUBS</b>                                                     |                                               |              |          |                                                                 |
| <i>Salix lasiolepis</i> / Hooker's willow                         |                                               |              |          |                                                                 |
| <i>Salix lucida</i> ssp. <i>laevis</i> / Pacific willow           |                                               |              |          |                                                                 |
| <i>Salix scouleriana</i> / Scoulers willow                        |                                               |              |          |                                                                 |
| <i>Salix reticulata</i> / Sitka willow                            |                                               |              |          |                                                                 |
| <i>Spiraea douglasii</i> / Hardhack spiraea                       |                                               |              |          |                                                                 |
| 1 gal.                                                            |                                               |              |          |                                                                 |
| <b>UPLAND AND WETLAND ZONE - Single Species Groups of 7 to 12</b> |                                               |              |          |                                                                 |
| Density (Plants Per Acre)                                         |                                               |              |          |                                                                 |
| 280                                                               |                                               |              |          |                                                                 |
| Group of 7 to 12                                                  |                                               |              |          |                                                                 |
| 2,100                                                             |                                               |              |          |                                                                 |
| <b>TREES</b>                                                      |                                               |              |          |                                                                 |
| <i>Acer macrophyllum</i> / Bigleaf maple                          |                                               |              |          |                                                                 |
| <i>Alnus rubra</i> / Red alder                                    |                                               |              |          |                                                                 |
| <i>Prinosax musgata</i> / Douglas fir                             |                                               |              |          |                                                                 |
| <i>Thuja heterophylla</i> / Western hemlock *                     |                                               |              |          |                                                                 |
| <b>SHRUBS</b>                                                     |                                               |              |          |                                                                 |
| <i>Acer circinnatum</i> / Vine maple                              |                                               |              |          |                                                                 |
| <i>Rosa pilosipes</i> / Clusters rose                             |                                               |              |          |                                                                 |
| <i>Salix lucida</i> ssp. <i>laevis</i> / Pacific willow           |                                               |              |          |                                                                 |
| <i>Salix scouleriana</i> / Scoulers willow                        |                                               |              |          |                                                                 |
| <i>Salix reticulata</i> / Sitka willow                            |                                               |              |          |                                                                 |
| <i>Spiraea douglasii</i> / Hardhack spiraea                       |                                               |              |          |                                                                 |
| 1 gal.                                                            |                                               |              |          |                                                                 |
| <b>UPLAND ZONE #1 - Single Species Groups of 1 to 12</b>          |                                               |              |          |                                                                 |
| Density (Plants Per Acre)                                         |                                               |              |          |                                                                 |
| 280                                                               |                                               |              |          |                                                                 |
| Group of 1 to 12                                                  |                                               |              |          |                                                                 |
| 2,100                                                             |                                               |              |          |                                                                 |
| <b>TREES</b>                                                      |                                               |              |          |                                                                 |
| <i>Acer macrophyllum</i> / Bigleaf maple                          |                                               |              |          |                                                                 |
| <i>Alnus rubra</i> / Red alder                                    |                                               |              |          |                                                                 |
| <i>Prinosax musgata</i> / Douglas fir                             |                                               |              |          |                                                                 |
| <i>Thuja heterophylla</i> / Western hemlock *                     |                                               |              |          |                                                                 |
| <b>SHRUBS</b>                                                     |                                               |              |          |                                                                 |
| <i>Acer circinnatum</i> / Vine maple                              |                                               |              |          |                                                                 |
| <i>Rosa pilosipes</i> / Clusters rose                             |                                               |              |          |                                                                 |
| <i>Salix lucida</i> ssp. <i>laevis</i> / Pacific willow           |                                               |              |          |                                                                 |
| <i>Salix scouleriana</i> / Scoulers willow                        |                                               |              |          |                                                                 |
| <i>Salix reticulata</i> / Sitka willow                            |                                               |              |          |                                                                 |
| <i>Spiraea douglasii</i> / Hardhack spiraea                       |                                               |              |          |                                                                 |
| 1 gal.                                                            |                                               |              |          |                                                                 |
| <b>UPLAND ZONE #2 - Single Species Groups of 3 to 7</b>           |                                               |              |          |                                                                 |
| Density (Plants Per Acre)                                         |                                               |              |          |                                                                 |
| 280                                                               |                                               |              |          |                                                                 |
| Group of 3 to 7                                                   |                                               |              |          |                                                                 |
| 2,100                                                             |                                               |              |          |                                                                 |
| <b>TREES</b>                                                      |                                               |              |          |                                                                 |
| <i>Acer macrophyllum</i> / Bigleaf maple                          |                                               |              |          |                                                                 |
| <i>Picea sitchensis</i> / Sitka spruce *                          |                                               |              |          |                                                                 |
| <i>Prinosax musgata</i> / Douglas fir                             |                                               |              |          |                                                                 |
| <i>Thuja heterophylla</i> / Western hemlock *                     |                                               |              |          |                                                                 |
| <b>SHRUBS</b>                                                     |                                               |              |          |                                                                 |
| <i>Acer circinnatum</i> / Vine maple                              |                                               |              |          |                                                                 |
| <i>Rosa pilosipes</i> / Clusters rose                             |                                               |              |          |                                                                 |
| <i>Salix lucida</i> ssp. <i>laevis</i> / Pacific willow           |                                               |              |          |                                                                 |
| <i>Salix scouleriana</i> / Scoulers willow                        |                                               |              |          |                                                                 |
| <i>Salix reticulata</i> / Sitka willow                            |                                               |              |          |                                                                 |
| <i>Spiraea douglasii</i> / Hardhack spiraea                       |                                               |              |          |                                                                 |
| 1 gal.                                                            |                                               |              |          |                                                                 |

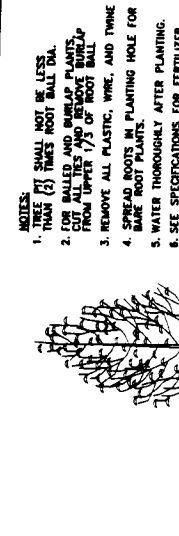
**Notes:**

1. Remove and protect all trees and shrubs not designated for removal. Provide, erect, and maintain barricades necessary to prevent access to area within drip-lines of existing trees. Allow no vehicular or pedestrian traffic, or storage of construction materials within barricades.
2. For each planting zone Contractor shall lay out a 10,000 s.f. test plot, in which the positions of all plants shall be marked with flags that are color coded to represent the species. Contractor shall submit a site plan, in which the positions of all plants shall be marked with flags that are color coded to represent the remainder of each zone.
3. Shrub masses shall consist of multiple single-species groups (see detail 6). Contractor shall ensure that these single-species groups have a variety of sizes and shapes, and that shrub masses have a variety of species. See planting schedule for numbers of plants in single-species groups.
4. Hydrosed all planting areas. Re-seed areas that are disturbed by subsequent work. Keep hydrosedding off any mulch shrubs except where needed to protect roots of conifers.

**Parametrix, Inc.**  
 5008 Lt. Washington Blvd. NE  
 Bellevue, WA 98004  
 PH: (425) 822-8880  
 Quality Service Through Employee Ownership  
 P. TSEWIT

| NO. | DATE | REVISIONS |
|-----|------|-----------|
|     |      |           |
|     |      |           |
|     |      |           |

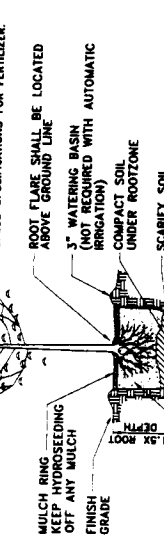
| NO. | DATE | REVISIONS |
|-----|------|-----------|
|     |      |           |
|     |      |           |
|     |      |           |



**DETAIL 1**  
TREE PLANTING (TYPICAL)

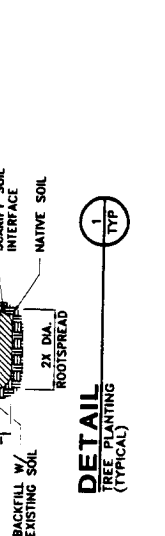
**NOTES:**

1. TREE SHALL NOT BE LESS THAN (3) TIMES ROOT BALL DIA.
2. FOR BALLED AND BURLAP PLANTS, THE ROOT BALL SHALL BE 1/3 OF ROOT BALL DIA.
3. REMOVE ALL PLASTIC, WIRE, AND TWINE FROM ROOT BALL.
4. SOWED ROOTS IN PLANTING HOLE FOR PLANTS.
5. WATER THOROUGHLY AFTER PLANTING.
6. SEE SPECIFICATIONS FOR FERTILIZER.



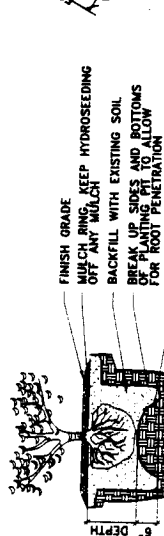
**DETAIL 2**  
PLANTING ON SLOPES (TYPICAL)

**NOTE:** REFER TO PLANTING DETAILS 1 AND 2 FOR INFORMATION SPECIFIC TO TREE AND SHRUB PLANTING.



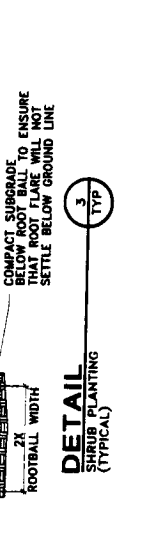
**DETAIL 3**  
SHRUB PLANTING (TYPICAL)

**NOTE:** ALL GROUNDCOVER/SHRUB SPACING SHALL BE EQUIVARIANT UNLESS OTHERWISE SPECIFIED.



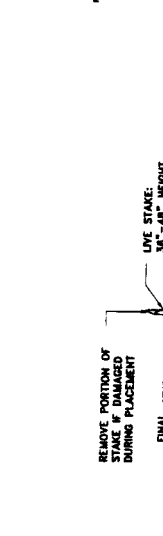
**DETAIL 4**  
TRIANGULAR SHRUB SPACING (TYPICAL)

**NOTE:** DISTANCE (D) ON CENTER AS REQUIRED TO MEET PLANTS PER ACRE STANDARD.



**DETAIL 5**  
LIVE STAKE (TYPICAL)

**NOTE:** AVOID UNIFORM PLANT GROUPINGS.



**DETAIL 6**  
SHAPES OF PLANTING MASSES (TYPICAL)

**AGENCY REVIEW**  
NOT FOR CONSTRUCTION

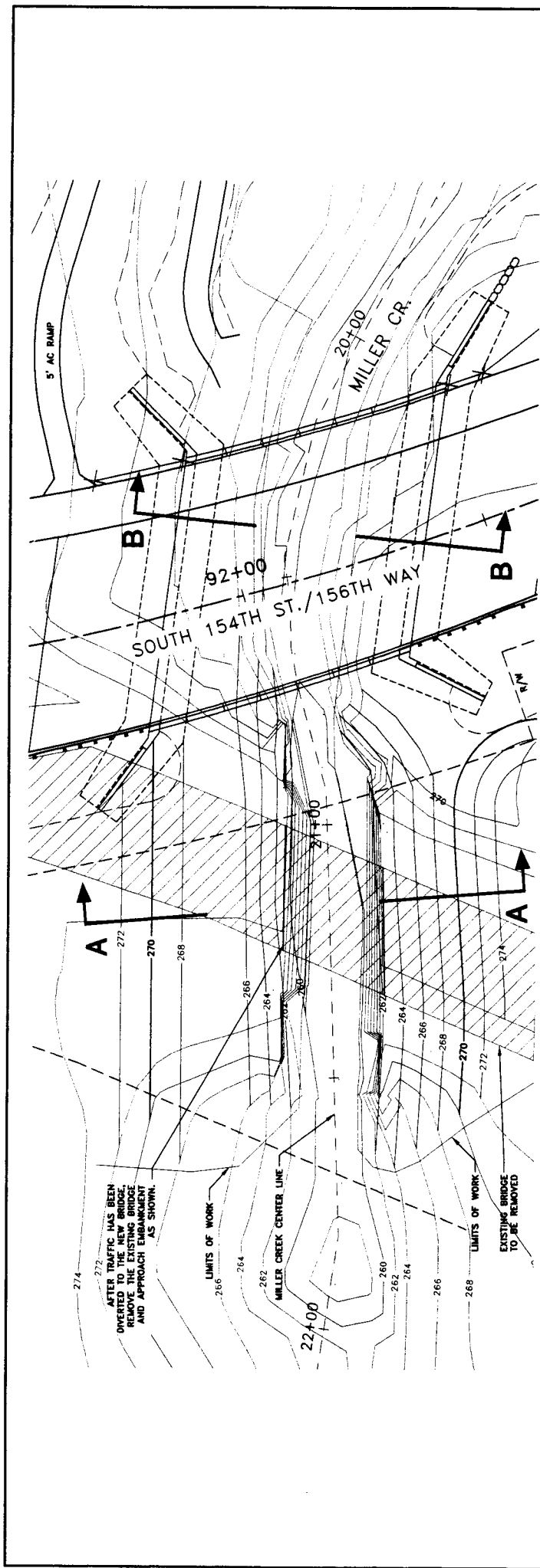
|               |              |
|---------------|--------------|
| PROJECT NO.   | 29128118     |
| DATE OF ISSUE | 10/15/07     |
| SCALE         | AS SHOWN     |
| DESIGNED BY   |              |
| CHECKED BY    |              |
| APPROVED BY   |              |
| STATIONING    | STA-9009-1.8 |

Port of Seattle  
 SEA-TAC INTERNATIONAL AIRPORT  
 MILLER CREEK WETLAND AND BUFFER ENHANCEMENTS  
 SHEET 001 PLANTING SCHEDULE AND DETAILS

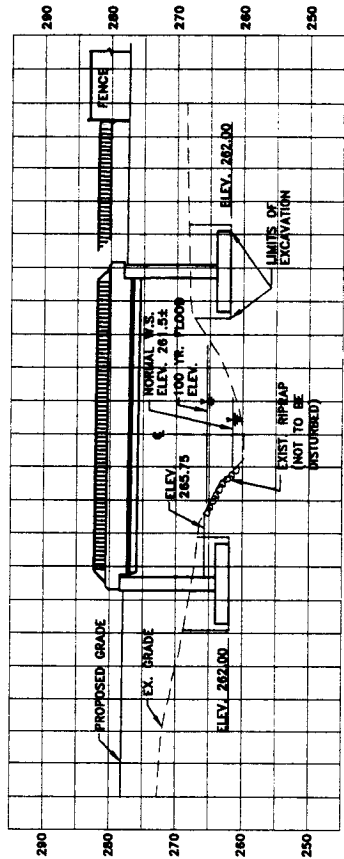
| NO. | DATE | REVISIONS |
|-----|------|-----------|
|     |      |           |
|     |      |           |
|     |      |           |

| NO. | DATE | REVISIONS |
|-----|------|-----------|
|     |      |           |
|     |      |           |
|     |      |           |

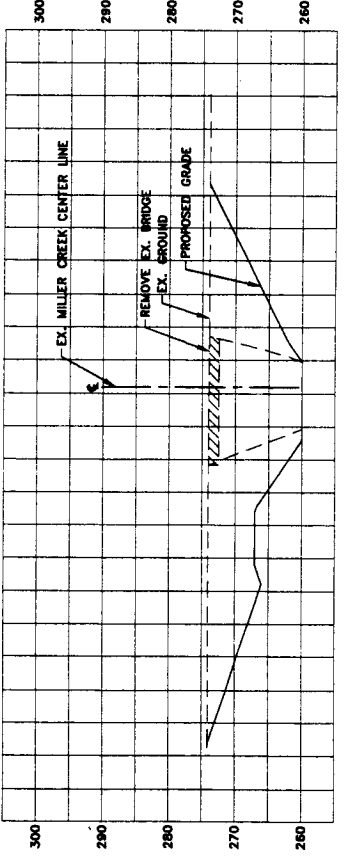
AR 049467



MILLER CREEK RECLAMATION  
SCALE IN FEET: 1" = 20'



MILLER CREEK CROSS SECTION - B  
SCALE IN FEET: 1" = 20'



MILLER CREEK CROSS SECTION - A  
SCALE IN FEET: 1" = 20'

CALL 48 HOURS  
BEFORE YOU DIG  
1-800-424-5555

**AGENCY REVIEW  
NOT FOR CONSTRUCTION**

**Port of Seattle  
SEA-TAC INTERNATIONAL AIRPORT  
MILLER CREEK INSTREAM AND BUFFER ENHANCEMENT  
PROJECT**

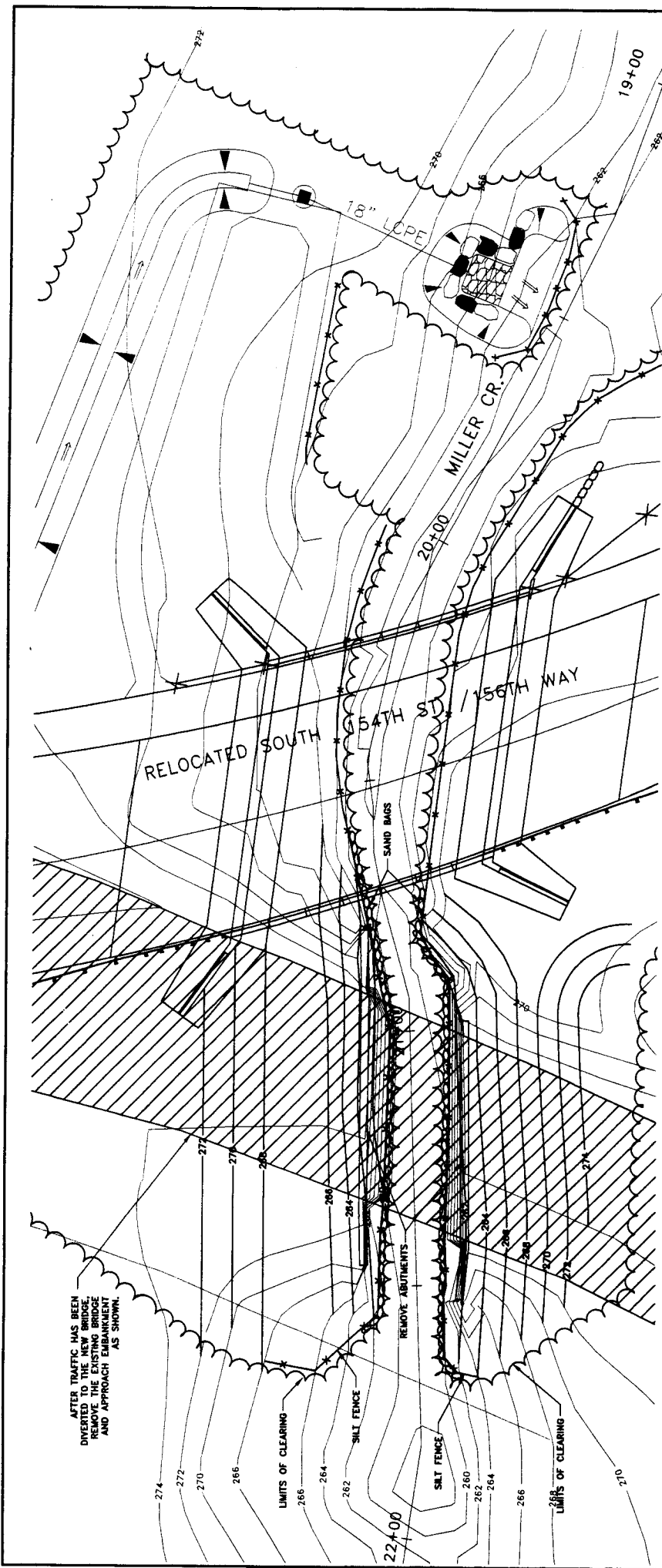
**MILLER CREEK GRADING AT S. 156TH WAY BRIDGE**

C3468  
281281P1  
STA-9804-P1  
APPENDIX B

| REVISIONS |      |    |             |
|-----------|------|----|-------------|
| NO.       | DATE | BY | DESCRIPTION |
|           |      |    |             |
|           |      |    |             |
|           |      |    |             |
|           |      |    |             |
|           |      |    |             |

**KATOS WARREN**  
 INCORPORATED  
 2003 Westerg Avenue  
 555 Market Place One  
 Seattle, WA 98121  
 (206) 446-4200  
 A Division of TransSystems Corporation





**BRIDGE REMOVAL & TEMPORARY EROSION CONTROL PLAN**



AFter TRAFfIC HAS BEEN  
 DIVERTED TO THE NEW BRIDGE,  
 REMOVE THE EXISTING BRIDGE  
 AND APPROACH EMBANKMENT  
 AS SHOWN.

**BRIDGE DEMOLITION SEQUENCE:**

1. INSTALL TESC SYSTEMS.
2. REMOVE BRIDGE DECK.
3. DIVERT STREAM FLOWS TO WEST SIDE OF CHANNEL WITH SAND BAGS.
4. REMOVE EAST ABUTMENT AND REGRADE PER PLAN. STABILIZE STREAM BANK WITH EROSION CONTROL BLANKET.
5. DIVERT STREAM FLOWS TO EAST SIDE OF CHANNEL WITH SAND BAGS.
6. REMOVE WEST ABUTMENT AND REGRADE PER PLAN. STABILIZE STREAM BANK WITH EROSION CONTROL BLANKET.
7. HYDROSEED NEW SLOPES AND ADJACENT DISTURBED AREAS. USE WETLAND MANAGEMENT SEED MIX FOR ELEVATIONS BELOW 266 AND UPLAND SEED MIX FOR ELEVATIONS ABOVE 266.

**NOTES:**

1. ALL WORK PERFORMED ADJACENT TO MILLER CREEK SHALL BE DONE IN ACCORDANCE WITH THE "HYDRAULIC PROJECT APPROVAL" FOR THIS PROJECT.
2. WETLANDS EXIST ADJACENT TO MILLER CREEK. DISTURBANCE TO THESE WETLANDS IS ONLY ALLOWED WITHIN THE CLEARING LIMITS SHOWN. FOR ADDITIONAL INFORMATION REFER TO SHEET T&Z OF THE TESC PLANS.
3. SAND BAGS, SILT FENCE, AND CLEAR PLASTIC COVERING TO BE INSTALLED WHERE NECESSARY TO MINIMIZE SEDIMENT SUSPENSION DURING BRIDGE REMOVAL.

CALL 48 HOURS  
 BEFORE YOU DIG  
 1-800-424-5555

**KATOS WARREN**  
 INCORPORATED  
 A Division of TransSystems Corporation  
 2003 Parkside Avenue  
 555 Market Place One  
 Seattle, WA 98121  
 (206) 446-4800

| NO. | DATE | DESCRIPTION | BY |
|-----|------|-------------|----|
|     |      |             |    |
|     |      |             |    |

| PROJECT NUMBER: | DATE:        |
|-----------------|--------------|
| C3496           | 29 12 11 P2  |
| PROJECT:        | DATE:        |
| DESIGNED BY:    | PROJECT NO.: |
| DRAWN BY:       |              |

**AGENCY REVIEW NOT FOR CONSTRUCTION**

Port of Seattle  
 SEA-TAC INTERNATIONAL AIRPORT  
 SOUTH 154TH STREET/156TH WAY/  
 MILLER CREEK RELOCATION  
 BRIDGE REMOVAL AND  
 TEMP. EROSION CONTROL PLAN

Appendix B. Descriptions of existing vegetation and proposed wetland and buffer enhancement actions along Miller Creek.

| Sheet Number             | Parcel Number  | Existing Conditions                                                                                                                                                                                                                                                                                                                                                                                                                                    | Proposed Mitigation Actions                                                                                                                                                                                                                                                                                                                                                        |
|--------------------------|----------------|--------------------------------------------------------------------------------------------------------------------------------------------------------------------------------------------------------------------------------------------------------------------------------------------------------------------------------------------------------------------------------------------------------------------------------------------------------|------------------------------------------------------------------------------------------------------------------------------------------------------------------------------------------------------------------------------------------------------------------------------------------------------------------------------------------------------------------------------------|
| See Appendix A, Sheet 11 | 97 through 100 | The parcels contain residential structures with lawn and ornamental plantings. Overstory is red alder near stream and native coniferous trees in upland.                                                                                                                                                                                                                                                                                               | Remove residential structures and plant lawn area with native upland trees and shrubs.                                                                                                                                                                                                                                                                                             |
| See Appendix A, Sheet 11 | 101            | This entire parcel is located on the east bank. Lawn is found above the banks of the creek and associated with the private residence. Overstory consists of Douglas fir in upland with red alder near stream.                                                                                                                                                                                                                                          | Remove residential structures and plant lawn area with upland trees and shrubs on east bank, west of the proposed 154 <sup>th</sup> Street relocation.                                                                                                                                                                                                                             |
| 11.1                     | 141            | The parcel is currently the location of South 156 <sup>th</sup> Way. This parcel also has areas of lawn and ornamental plantings. Overstory has native coniferous trees with an understory of ornamental shrubs and blackberry.                                                                                                                                                                                                                        | Remove road and plant native upland trees and shrubs. Plant upland trees and shrubs in lawn areas. Remove areas of blackberry and plant with native trees and shrubs.                                                                                                                                                                                                              |
| 11.1                     | 142            | The east bank contains a steep slope with black cottonwood in the overstory and English ivy and Himalayan blackberry below. The west bank also consists of a steep slope with western hemlock and weeping willow in the overstory and cherry laurel and English ivy dominant below. A residence is located in the outer half of the buffer.                                                                                                            | No action to be taken on the east bank because of the steep slope. Remove existing structures, English ivy, and cherry laurel on west bank and plant with upland trees and shrubs.                                                                                                                                                                                                 |
| 11.1                     | 143            | The eastern bank contains a red alder riparian wetland fringe with a lawn in the remaining portion of the buffer. A residence is located in outer third of the buffer on the west bank. A terraced yard leads down to the creek. Vegetation near the residence and along the slope includes red alder, black cottonwood, and western redcedar with English ivy dominant on the constructed terraces.                                                   | Plant east bank wetland fringe and lawn with trees and shrubs. Remove residential structures on west bank and plant with trees and shrubs. Remove creosote timbers, install erosion control fabric or other BMP, and plant with native trees and shrubs. Remove English ivy and plant wetland fringe with native trees and shrubs.                                                 |
| 11.1                     | 144            | Residential structures are located in the outer portion of the buffer.                                                                                                                                                                                                                                                                                                                                                                                 | Remove structures and plant with upland trees and shrubs.                                                                                                                                                                                                                                                                                                                          |
| 11.1                     | 146            | A red alder and shrub wetland are located on the east bank. Trees on the west bank include red alder and western hemlock with English holly, cherry laurel, Himalayan blackberry, and reed canarygrass in the understory.                                                                                                                                                                                                                              | Remove garden debris on east bank and interplant with native wetland shrubs. Remove the blackberry and cherry laurel and interplant with native coniferous trees on west bank and on upland areas near residence.                                                                                                                                                                  |
| 11.1                     | 147            | Dominant canopy species on east and west bank include red alder and western hemlock. English holly, cherry laurel, Himalayan blackberry, reed canarygrass, and lawn are dominant in the understory.                                                                                                                                                                                                                                                    | Remove residence on west bank and clear of English holly, cherry laurel, and blackberry. Plant cleared areas with upland native trees and shrubs on both the east and west banks.                                                                                                                                                                                                  |
| 11.1                     | 148            | Lawn is located above the creek on the east bank. Red alder riparian wetland is located along the east bank of the creek with ornamental trees, English holly, and cherry laurel also near the creek. Himalayan blackberry and English ivy dominate understory along the creek edge. The west bank is a steep slope with cherry laurel, English ivy, and Himalayan blackberry.                                                                         | Plant lawn area with native upland vegetation on east bank. Remove English holly, cherry laurel, English ivy, and blackberry along the creek edge and plant with native vegetation.                                                                                                                                                                                                |
| 11.1                     | 152            | Most of the buffer on this parcel is located on the west bank. Representative vegetation on the upland portion of the west bank includes lawn and ornamental trees associated with the residence. Red alder and shrubs grow near the creek. Himalayan blackberry is dominant along the steep slope on the west bank south of South 157 <sup>th</sup> Street.                                                                                           | Remove residence on west bank and plant lawn area. Interplant creek bank with upland shrubs and trees. Remove Himalayan blackberry south of South 157 <sup>th</sup> Street and interplant with western redcedar and native shrubs.                                                                                                                                                 |
| 11.1                     | 153            | Lawn is located beyond the edge of the east bank, adjacent to residential structures. Himalayan blackberry is the dominant plant along the east bank, adjacent to the creek. Some salmonberry is found in a riparian wetland on the east bank. Western redcedar and Douglas fir trees are located in the lawn area. The west bank is vegetated with western redcedar and Douglas fir in the canopy. Himalayan blackberry dominates in the shrub layer. | Remove residences and paved driveway on east bank and plant large areas of upland lawn and wetland lawn with upland and wetland trees and shrubs. No action immediately next to the channel on the west bank because it is already heavily vegetated. Interplant streambank slope with coniferous tree species. Remove areas of blackberry and plant with native trees and shrubs. |
| 11.1                     | 154            | Representative vegetation on this upland parcel includes lawn and ornamental trees associated with a residence. Areas of the parcel contain non-native species including Himalayan blackberry and English holly. Native plants include Douglas fir, western redcedar, and red alder.                                                                                                                                                                   | Remove residence and paved driveway and plant areas with upland trees and shrubs. Remove blackberry and English holly and plant with native trees and shrubs.                                                                                                                                                                                                                      |
| 11.1/1.2                 | 179            | Ornamental trees, shrubs, and lawn are found on the bench above the creek with western redcedar and Douglas fir dominant on the east bank. Himalayan blackberry dominates the entire steep slope along the streambank.                                                                                                                                                                                                                                 | Remove residence above the eastern creek bank and plant large areas of lawn with native upland vegetation. Remove Himalayan blackberry along streambank and plant native trees and shrubs.                                                                                                                                                                                         |
| 11.1                     | 180            | The representative vegetation on the west bank includes ornamental trees, shrubs, and lawn that are associated with the existing residence. Western redcedar is also present.                                                                                                                                                                                                                                                                          | Remove residence from west bank and plant large areas of lawn with native wetland and upland vegetation.                                                                                                                                                                                                                                                                           |
| 11.1/1.2                 | 182            | Representative vegetation on the west bank includes western redcedar, black cottonwood, ornamental trees, shrubs, and lawn associated with the existing residence. English ivy is also present.                                                                                                                                                                                                                                                        | Remove residence and plant native vegetation on west bank. Remove English ivy and plant native vegetation.                                                                                                                                                                                                                                                                         |
| 1.2                      | 183            | Ornamental shrubs and lawn are associated with the residence. Vegetation in the canopy layer near the creek includes black cottonwood.                                                                                                                                                                                                                                                                                                                 | Remove residence and associated structures and plant lawn with native upland coniferous tree species and native shrubs.                                                                                                                                                                                                                                                            |
| 1.2                      | 184            | Private residence and lawn area is located on the west bank. Black cottonwood, red alder, western redcedar, and western hemlock compose the tree layer along the east and west banks. The shrub layer includes Himalayan blackberry, red twig dogwood, salmonberry, and willow.                                                                                                                                                                        | Remove residence and plant area with native trees and shrubs. Plant west bank above the creek with upland trees and shrubs. Remove patches of Himalayan blackberry from the west bank of the creek edge and plant native riparian shrubs.                                                                                                                                          |
| 1.2                      | 185 and 186    | Representative vegetation includes ornamental trees, shrubs, and lawn associated with the two residences on the east bank.                                                                                                                                                                                                                                                                                                                             | Remove existing residence and plant area with native trees and shrubs on east and west bank.                                                                                                                                                                                                                                                                                       |
| 1.2                      | 210            | The east bank contains ornamental trees, shrubs, lawn, and an existing residence. Red alder, western redcedar, Douglas fir, salmonberry, and western hazelcut are also present near the creek.                                                                                                                                                                                                                                                         | Remove existing residence and outbuildings on east bank and plant native trees and shrubs.                                                                                                                                                                                                                                                                                         |
| 1.2                      | 211 and 212    | Lawn, ornamental trees, western redcedar, and red alder are associated with existing residences.                                                                                                                                                                                                                                                                                                                                                       | Remove residences and plant lawn area with native trees and shrubs.                                                                                                                                                                                                                                                                                                                |
| 1.2                      | 213            | A lawn area associated with the residence is on the east bank. Overstory vegetation is western redcedar with salmonberry, willow, cherry laurel, and bamboo understory.                                                                                                                                                                                                                                                                                | Remove residence, cherry laurel, and bamboo from east bank and plant lawn and other areas with native vegetation.                                                                                                                                                                                                                                                                  |

CALL US TODAY! BEFORE YOU BID!  
1-800-424-5555

**Paramatrix, Inc.**  
6808 L. Washington Blvd NE  
Bellevue, WA 98003  
Ph: (425) 822-8800  
Fax: (425) 822-8800  
www.paramatrix.com  
Quality Service Through Employee Ownership

PROJECT NO: 05-0001  
DATE: 05/01/05  
DRAWN BY: J. F. HENRI  
CHECKED BY: J. F. HENRI  
SCALE: AS SHOWN

PORT OF SEATTLE  
SEATTLE-TACOMA INTERNATIONAL AIRPORT  
MILLER CREEK INSTREAM AND BUFFER ENHANCEMENTS  
EXISTING VEGETATION & WETLAND ENHANCEMENT ACTIONS

AGENCY REVIEW  
NOT FOR CONSTRUCTION

DATE: 05/01/05  
DRAWN BY: J. F. HENRI  
CHECKED BY: J. F. HENRI  
SCALE: AS SHOWN

05/01/05 5:16 AM AKK:TAJ

Appendix B. Descriptions of existing vegetation and proposed wetland and buffer enhancement actions along Miller Creek (continued).

| Street Number | Parcel Number   | Existing C conditions                                                                                                                                                                                                                                                                                                                                                                  | Proposed Mitigation Actions                                                                                                                                                                                                                        |
|---------------|-----------------|----------------------------------------------------------------------------------------------------------------------------------------------------------------------------------------------------------------------------------------------------------------------------------------------------------------------------------------------------------------------------------------|----------------------------------------------------------------------------------------------------------------------------------------------------------------------------------------------------------------------------------------------------|
| 1.2           | 214             | The residence has a landscape including western redcedar, ornamental trees, shrubs, and lawn. A steep slope adjacent to the creek is vegetated with grasses.                                                                                                                                                                                                                           | Remove residence and plant lawn and other areas with native upland vegetation.                                                                                                                                                                     |
| 1.2           | 215             | The east bank contains a forested wetland dominated by red alder. The representative vegetation on the west bank includes western redcedar, ornamental trees, shrubs, and lawn associated with the existing residence.                                                                                                                                                                 | Plant both upland and wetland vegetation on the east bank. Remove the existing residence on the west bank and plant lawn with a combination of native wetland and upland trees and shrubs.                                                         |
| 1.2           | 216             | The west bank has a red alder forest with an understory of Himalayan blackberry, cherry laurel, English holly, salmonberry, and western hazelnut.                                                                                                                                                                                                                                      | Plant shrubs and native coniferous trees on east bank. Remove residence on west bank, above the creek bank, and plant with upland trees and shrubs. Remove areas of blackberry, cherry laurel, and English holly and plant with native vegetation. |
| 1.5.1         | 242 through 244 | The residences are associated with ornamental trees, shrubs, and lawn are in the outer portion of the buffer on the north and west side of the creek. Red alder, black cottonwood, and Himalayan blackberry are dominant on a slope and adjacent to the creek.                                                                                                                         | Remove residences and areas of blackberry and plant with native trees and shrubs. Plant native vegetation in lawn areas.                                                                                                                           |
| 1.5.1         | 247             | The existing residence has a landscape including ornamental trees, shrubs, and lawn.                                                                                                                                                                                                                                                                                                   | Remove residence. Plant open areas with native trees and shrubs.                                                                                                                                                                                   |
| 1.5.1         | 248             | A large lawn area is associated with existing residence. Black cottonwood and red alder dominate the tree layer. Shrubs include Himalayan blackberry, red twig dogwood, English holly, and cherry laurel.                                                                                                                                                                              | Remove residence and English holly. Plant native trees and shrubs in the lawn area on west bank.                                                                                                                                                   |
| 1.5.1         | 249             | A residence with areas of compacted soil is located adjacent to the creek. Black cottonwood and red alder dominate the tree layer along the east bank of the creek. The shrub layer near the creek edge includes Himalayan blackberry, red twig dogwood, English holly, and cherry laurel.                                                                                             | Remove residence and shrubs. Remove blackberry, English holly, and cherry laurel and plant native vegetation.                                                                                                                                      |
| 1.5.1         | 251 and 252     | Residences with associated ornamental trees, shrubs, and lawn are in the outer portion of the buffer. Black cottonwood, red alder, Himalayan blackberry, and a lawn area are near the creek.                                                                                                                                                                                           | Remove residences and plant native trees and shrubs. Plant native vegetation in lawn areas and areas where blackberry plants are removed.                                                                                                          |
| 1.5.1         | 253             | Residence and associated lawn, red alder and western redcedar grow near the creek.                                                                                                                                                                                                                                                                                                     | Remove structure, plant lawn and open areas with native vegetation. Underplant with native trees and shrubs near the creek.                                                                                                                        |
| 1.2           | 255             | Himalayan blackberry and Japanese knotweed dominate the entire parcel.                                                                                                                                                                                                                                                                                                                 | Clear area within the buffer and remove top 6 to 12 inches of soil, amend with topsoil if necessary, and plant with upland shrubs and trees.                                                                                                       |
| 1.2/1.3       | 256             | Himalayan blackberry and Japanese knotweed dominate the entire parcel.                                                                                                                                                                                                                                                                                                                 | Clear area within the buffer and plant with wetland and upland trees and shrubs.                                                                                                                                                                   |
| 1.2/1.3       | 257 and 258     | The parcels are vegetated with lawn, ornamental trees, and shrub, associated with the existing residences on the east bank.                                                                                                                                                                                                                                                            | Remove existing structures and plant a combination of native upland trees and shrubs near the residences and wetland shrubs near the creek edge.                                                                                                   |
| 1.3           | 259             | The dominant vegetation includes ornamental shrubs and lawn associated with an existing residence on the east bank. A stand of quaking aspen is located on the creek's bank.                                                                                                                                                                                                           | Remove existing structure and plant a combination of native wetland and upland trees and shrubs.                                                                                                                                                   |
| 1.3           | 260             | Representative vegetation on the west bank includes ornamental fruit trees and lawn.                                                                                                                                                                                                                                                                                                   | Remove trees and excavate fill material to connect stream with floodplain, replant buffer with native upland trees and shrubs. Plant benches along the creek with emergent species if appropriate.                                                 |
| 1.2           | 262-264, 267    | Typical vegetation includes ornamental trees, shrubs, and lawn. Overstory vegetation includes native coniferous and deciduous trees.                                                                                                                                                                                                                                                   | Remove residences and plant open areas with native trees and shrubs.                                                                                                                                                                               |
| 1.3           | 265, 266        | The dominant vegetation includes ornamental trees, shrubs, and lawn that are associated with the existing residence. Overstory vegetation also includes patches of native coniferous and deciduous trees.                                                                                                                                                                              | Remove existing structure and plant a combination of native wetland and upland trees and shrubs in cleared and lawn areas.                                                                                                                         |
| 1.3           | 268             | The east bank is a red alder-dominated wetland with Himalayan blackberry in the shrub layer. The west bank is dominated by ornamental lawn.                                                                                                                                                                                                                                            | Remove patches of Himalayan blackberry on the east bank and interplant with native trees and shrubs. Plant lawn area with native upland trees and shrubs.                                                                                          |
| 1.3           | 276             | The west bank is a black cottonwood and red alder upland dominated by a Himalayan blackberry shrub layer.                                                                                                                                                                                                                                                                              | Remove patches of Himalayan blackberry and interplant with native wetland trees and shrubs.                                                                                                                                                        |
| 1.3           | 277             | The east bank is a red alder-dominated wetland that also contains black cottonwood and western hemlock. The understory is dominated by Himalayan blackberry with salmonberry and western hazelnut. The west bank is dominated by black cottonwood and red alder with Himalayan blackberry in the shrub layer.                                                                          | Remove patches of Himalayan blackberry and interplant native wetland trees and shrubs on east and west banks. To avoid damage to existing vegetation and wetland soil, planting will be limited to accessible areas of the existing wetland.       |
| 1.3           | 278             | The east bank is a black cottonwood and red alder wetland dominated by a Himalayan blackberry shrub layer. The west bank is a red alder-dominated wetland with black cottonwood and western hemlock also present. The understory is dominated by Himalayan blackberry with traces of salmonberry and western hazelnut.                                                                 | Remove patches of Himalayan blackberry and interplant with trees and shrubs on both the east and west banks. No planting will occur on the steep slopes in areas where salmonberry is dominant.                                                    |
| 1.3           | 287             | The parcel has areas of Himalayan blackberry, ornamental shrubs, and grasses with an overstory of red alder and big-leaf maple.                                                                                                                                                                                                                                                        | Remove blackberry and plant open areas with native trees and shrubs.                                                                                                                                                                               |
| 1.3           | 290             | The east bank is a red alder-dominated wetland with some big-leaf maple present. The shrub layer is Himalayan blackberry and Japanese knotweed with some Indian plum, western hazelnut, and salmonberry present. The west bank is a black cottonwood, red alder, and western redcedar forest. Himalayan blackberry, salmonberry, and western hazelnut are dominant in the shrub layer. | Remove patches of Himalayan blackberry and interplant native wetland trees and shrubs on both the east and west banks. Remove Japanese knotweed and plant native vegetation.                                                                       |
| 1.3           | 291             |                                                                                                                                                                                                                                                                                                                                                                                        |                                                                                                                                                                                                                                                    |

CALL 48 HOURS BEFORE YIELDING  
1-800-424-5555

**Parametrix, Inc.**  
5816 11<sup>th</sup> Washington Blvd NE  
Kirkland, WA 98033  
Ph: (425) 872-8800  
www.parametrix.com

PROJECT: MILLER CREEK WETLAND RESTORATION  
DATE: 10/15/2011  
SCALE: AS SHOWN  
DRAWN BY: J. L. BROWN  
CHECKED BY: J. L. BROWN  
APPROVED BY: J. L. BROWN

| NO. | DATE | BY | DESCRIPTION |
|-----|------|----|-------------|
|     |      |    |             |
|     |      |    |             |
|     |      |    |             |
|     |      |    |             |

Port of Seattle  
SEA-TAC INTERNATIONAL AIRPORT  
MILLER CREEK INSTREAM AND BUFFER ENHANCEMENTS  
EXISTING VEGETATION & WETLAND ENHANCEMENT ACTIONS

AGENCY REVIEW  
NOT FOR CONSTRUCTION

AR 049471

Appendix B. Descriptions of existing vegetation and proposed wetland and buffer enhancement actions along Miller Creek (continued).

| Sheet Number | Parcel Number   | Existing Conditions                                                                                                                                                                                                                                                                                                                                                                                                                                                                                                                    | Proposed Mitigation Actions                                                                                                                                                                                                                                                                                                         |
|--------------|-----------------|----------------------------------------------------------------------------------------------------------------------------------------------------------------------------------------------------------------------------------------------------------------------------------------------------------------------------------------------------------------------------------------------------------------------------------------------------------------------------------------------------------------------------------------|-------------------------------------------------------------------------------------------------------------------------------------------------------------------------------------------------------------------------------------------------------------------------------------------------------------------------------------|
| 1.3/1.4      | 292             | The east bank is a red alder-dominated wetland with small amounts of big-leaf maple and Douglas fir. The shrub layer is Himalayan blackberry and Japanese knotweed with some Indian plum, western hazelnut, and salmonberry present. Reed canarygrass dominates the herbaceous layer. The west bank is a black cottonwood, red alder, and western redcedar forest. The shrub layer is dominated by Himalayan blackberry and Japanese knotweed with salmonberry and western hazelnut.                                                   | Remove portions of Himalayan blackberry on east bank and interplant with upland shrubs. Remove Japanese knotweed on the west bank and plant with native tree and shrubs.                                                                                                                                                            |
| 1.4          | 298             | The east bank is a red alder-dominated wetland with big-leaf maple and Douglas fir also present. Himalayan blackberry and Japanese knotweed dominate the shrub layer. Western redcedar dominates the west bank with big-leaf maple and red alder. Himalayan blackberry and Japanese knotweed are the dominant shrubs with willow, Indian plum, and cherry laurel also present. Several large snags are also present.                                                                                                                   | No action is recommended on the east bank due to the high quality of the existing native vegetation. Remove patches of Himalayan blackberry and interplant with native wetland and upland trees and shrubs near the creek edge on the west bank. Remove abandoned vehicles from upland buffer area.                                 |
| 1.4          | 299             | The east bank is a red alder-dominated wetland with some big-leaf maple occurring adjacent to the upland. The understory includes Himalayan blackberry, with skunk cabbage and creeping buttercup dominant in the herbaceous layer.                                                                                                                                                                                                                                                                                                    | Remove Himalayan blackberry and plant native riparian and upland vegetation.                                                                                                                                                                                                                                                        |
| 1.4          | 300             | A red alder wetland is located immediately next to the creek with pasture grasses located to the east. Big-leaf maple grows in the upland areas. Dominant west bank trees include western redcedar, red alder, and big-leaf maple. Himalayan blackberry is dominant in the shrub stratum with red-twig dogwood, willow species, and red elderberry.                                                                                                                                                                                    | Remove areas of Himalayan blackberry found in the wetland on the east bank and interplant with native wetland vegetation. Plant pasture with wetland trees and shrubs. Remove patches of Himalayan blackberry from the west bank and interplant with upland trees and shrubs.                                                       |
| 1.4          | 301             | Red alder is the dominant tree species on the east bank, with Himalayan blackberry and Japanese knotweed present along the stream and in a pasture. Western redcedar, big-leaf maple, and red alder are present on the west bank. Dominant shrub species include Himalayan blackberry and Japanese knotweed. A small island containing Japanese knotweed and Himalayan blackberry is present in the center of Miller Creek along the boundary of parcels 301 and 303.                                                                  | Remove English holly, Himalayan blackberry, and Japanese knotweed, then interplant with native coniferous trees to provide shading.                                                                                                                                                                                                 |
| 1.4/1.5      | 303             | A red alder-dominated wetland is on the east bank of the creek with large patches of skunk cabbage. The west bank contains a large stand of western redcedar. On the west bank, Himalayan blackberry, Japanese knotweed, reed canarygrass, and ornamental lawn dominate immediately adjacent to the creek, with salmonberry and western hazelnut also occurring. Cow parsnip is also present. A small island containing Japanese knotweed and Himalayan blackberry is present in the stream along the boundary of parcels 301 and 303. | Remove English holly, cherry laurel, and Japanese knotweed and plant native trees and shrubs. Plant areas of ornamental lawn with native wetland shrubs. Remove patches of Himalayan blackberry and interplant native coniferous trees in existing red alder wetland. Remove cow parsnip and replant with native shrub species.     |
| 1.5          | 305 and 306     | Red alder dominates the tree layer with Douglas fir also present. There are also ornamental trees and shrubs. Shrub layer includes Himalayan blackberry, English holly, salmonberry, western hazelnut, and ornamental shrub species.                                                                                                                                                                                                                                                                                                   | Remove areas of Himalayan blackberry and interplant with native trees and shrubs. Remove English holly and plant native trees and shrubs. Plant areas of open lawn with native upland trees and shrubs.                                                                                                                             |
| 1.4          | 308 through 310 | A large stand of black cottonwood dominates the tree layer on west bank with red alder and western hemlock also present. Several large stands of ornamental trees and shrubs are located on the bank. Shrub layer includes Himalayan blackberry, salmonberry, western hazelnut and ornamental rhododendron. Cow parsnip grows on west bank. There are existing residences on parcels 309 and 310.                                                                                                                                      | Remove patches of the English holly and cherry laurel at the north and east portion of parcel 310 and replant with native trees and shrubs. Remove residences and areas of blackberry and plant open areas with native vegetation.                                                                                                  |
| 1.4          | 311             | Red alder is the dominant tree species with Douglas fir and western hemlock also present. Ornamental trees grow on both banks, along with some English holly and cherry laurel. Red-twig dogwood dominates both banks (within 25 to 30 ft of the bank) with Himalayan blackberry and reed canarygrass also present.                                                                                                                                                                                                                    | Remove patches of Himalayan blackberry on both the east and west banks and interplant native coniferous trees. Underplant ornamental trees with native coniferous and deciduous tree and shrub species.                                                                                                                             |
| 1.4/1.5      | 312             | A forested wetland is located on the east bank. Red alder is the dominant tree species on the east and west banks with Douglas fir present on the west bank. Himalayan blackberry, Japanese knotweed, and reed canarygrass dominate both banks. Red-twig dogwood becomes dominant toward the northern property line.                                                                                                                                                                                                                   | Remove patches of Himalayan blackberry and Japanese knotweed within wetland and interplant native shrubs and plant native upland and wetland vegetation on both the east and west banks. Remove residence and associated structures from the outer portion of the buffer on the west bank and replant with upland trees and shrubs. |
| 1.5          | 313             | A tree layer is dominated by red alder and big-leaf maple on the east bank, with Himalayan blackberry and Japanese knotweed dominant in the shrub stratum. Reed canarygrass, Himalayan blackberry, and ornamental lawn dominate the west bank, especially in areas without overstory vegetation. Ornamental nursery stock trees, grown in rows, are present within the buffer on the west bank.                                                                                                                                        | Remove patches of Japanese knotweed and patches of Himalayan blackberry from the east and west bank and interplant with native trees and shrubs. Remove some non-native nursery stock from the site.                                                                                                                                |
| 1.5          | 314 and 315     | The tree layer includes western hemlock, western redcedar, and big-leaf maple. Himalayan blackberry and Japanese knotweed are the dominant shrubs with salmonberry also present. Reed canarygrass and ornamental lawn are dominant in the herbaceous layer. Ornamental nursery stock trees grown in agricultural rows are located on the west bank.                                                                                                                                                                                    | Remove Japanese knotweed, areas of ornamental lawn, and Himalayan blackberry and plant native wetland and upland vegetation. Excavate fill material along the west bank to expand the floodplain. Plant new floodplain area with native trees and shrubs. Remove and/or redistribute ornamental nursery stock.                      |
| 1.5          | 316             | The tree layer includes big-leaf maple, western hemlock, and western redcedar. Big-leaf maple is dominant on the east bank. The shrub layer includes Himalayan blackberry on the east bank and Japanese knotweed and Himalayan blackberry on the west bank. Vegetation disturbance and soil compaction have resulted from adjacent commercial nursery.                                                                                                                                                                                 | Interplant native coniferous tree species on east bank. Remove patches of Japanese knotweed, Himalayan blackberry, and bamboo from the west bank and plant with native vegetation. Scarify and amend soil in compacted areas, remove all structures, and plant native trees and shrubs.                                             |
| 1.5          | 317             | Dominant trees on the east bank include red alder and black cottonwood with traces of western redcedar. Himalayan blackberry dominates the shrub layer with salmonberry and Indian plum also present. Red alder with traces of western redcedar are found in the canopy layer with Himalayan blackberry and lawn below.                                                                                                                                                                                                                | Remove riprap and large patches of blackberry located along the east bank of the creek. Plant native coniferous tree species and upland shrubs. Remove driveway and patches of Himalayan blackberry and plant native vegetation on the west bank within the lawn area.                                                              |

CALL 48 HOURS BEFORE YIELDING  
1.800.424.5545

**Paramatrix Inc.**  
5808 14<sup>th</sup> Washington Blvd NE  
Bellevue, WA 98003  
PH: (206) 822-8800  
Quality Service Through Employee Ownership

PROJECT: MILLER CREEK WETLAND RESTORATION  
CLIENT: PORT OF SEATTLE  
DATE: NOVEMBER 2001  
DRAWN BY: P. FENST

AGENCY REVIEW  
**NOT FOR CONSTRUCTION**

Port of Seattle  
SEA-TAC INTERNATIONAL AIRPORT  
MILLER CREEK INSTREAM AND BUFFER ENHANCEMENTS  
**EXISTING VEGETATION & WETLAND ENHANCEMENT ACTIONS**



**Appendix B. Description of existing vegetation and buffer enhancement actions along Miller Creek (continued).**


| Sheet Number    | Parcel Number | Location                                  | Existing Conditions                                                                                                                                                                                                                                                                                                                                                                                                                                                                                                                                                                                                                                          | Proposed Mitigation Actions                                                                                                                                                                                                                                                                                                                                                                                                                                                                                                                                                                     |
|-----------------|---------------|-------------------------------------------|--------------------------------------------------------------------------------------------------------------------------------------------------------------------------------------------------------------------------------------------------------------------------------------------------------------------------------------------------------------------------------------------------------------------------------------------------------------------------------------------------------------------------------------------------------------------------------------------------------------------------------------------------------------|-------------------------------------------------------------------------------------------------------------------------------------------------------------------------------------------------------------------------------------------------------------------------------------------------------------------------------------------------------------------------------------------------------------------------------------------------------------------------------------------------------------------------------------------------------------------------------------------------|
| I.5.3 and I.5.4 | 218           | Wetland / Stream                          | The area west of Water D is a young alder forest with relatively dense Himalayan blackberry and field morning glory in the understory. A driveway with a culvert has been placed in the wetland, at the north end of the wetland on this parcel.<br><br>Upland areas are grassed or vegetated with red alder, western redbud, big-leaf maple, or cherry laurel. A driveway crosses the upland.                                                                                                                                                                                                                                                               | Clear Himalayan blackberry from the wetland. Remove the driveway and culvert from the wetland. Regrade the area to match historic contours. Use BMPs and bioengineering techniques to stabilize the area after work is complete. Plant western redbud and hemlock in red alder forest understory.<br><br>Remove Himalayan blackberry and cherry laurel on southern property boundary. Remove driveway and associated fill, and regrade to match contours. Revegetate upland with tree and shrub species.<br><br>Control blackberry and plant wetland trees and shrubs in emergent wetland area. |
| I.5.3           | 219           | Wetland / Stream                          | West of Water D, wetland vegetation consists of lady fern, soft rush, small-fruited bulrush, common velvetgrass, watercress, and creeping buttercup. East of Water D, wetland vegetation consists of field horsetail, field morning glory, and Himalayan blackberry.                                                                                                                                                                                                                                                                                                                                                                                         | Remove driveway, house, shed and associated fill. Regrade to match historic conditions. Remove Himalayan blackberry and plant with trees. Near the wetland edge plant red alder and black cottonwood.                                                                                                                                                                                                                                                                                                                                                                                           |
| I.5.3           | 220           | Wetland / Stream                          | The wetlands consist of field horsetail, common velvetgrass, and creeping buttercup.<br><br>The parcel is forested with some Himalayan blackberry in the understory.                                                                                                                                                                                                                                                                                                                                                                                                                                                                                         | Infill plant with specified plant species.<br><br>Remove blackberry located on the north side of the parcel and near the wetland edge. Plant sun-tolerant native coniferous tree species.                                                                                                                                                                                                                                                                                                                                                                                                       |
| I.5.3           | 221           | Wetland / Stream                          | Vegetation in the wetland consists of field horsetail, common velvetgrass, and creeping buttercup. Watercress is growing in Water D and three fruit trees are located in the wetland. Water D is lined with creosote railroad ties. Some reed canarygrass and Himalayan blackberry are located on the east property edge.                                                                                                                                                                                                                                                                                                                                    | Remove creosote railroad ties, grade the area back to connect the stream with the floodplain, remove the blackberry, and replant the area with native wetland trees and shrubs.                                                                                                                                                                                                                                                                                                                                                                                                                 |
| I.5.3           | 222           | Upland (House remains)                    | This parcel is grassed with ornamental plantings around the house. The house is located at the wetland edge.                                                                                                                                                                                                                                                                                                                                                                                                                                                                                                                                                 | Remove the residential structures and associated fill. Regrade to match historic conditions.<br><br>Remove Himalayan blackberry on the north side and near the wetland edge. Plant open areas with sun-tolerant coniferous tree species.<br><br>Remove Himalayan blackberry and reed canarygrass on the east side. Plant willows.                                                                                                                                                                                                                                                               |
| I.5.3           | 223           | Wetland / Stream                          | On the west side of the channel, the wetland borders the north, south, and east sides of the house. The wetland is dominated by creeping buttercup, field horsetail, and small-fruited bulrush. The east side of the channel is dominated by reed canarygrass with field horsetail and creeping buttercup. Himalayan blackberry borders the southern portion of the wetland.<br><br>A house is adjacent to the wetland. The upland area is lawn with a mature Douglas fir and small ornamental trees. Small ornamental shrubs are planted around the house. A compacted gravel driveway is located on the south side of the parcel.                          | Remove house, driveway, and associated fill. Regrade to smooth contours. Avoid damage to Douglas fir. Remove ornamental vegetation. Replant the area with native tree and shrub species.<br><br>Remove fence. Remove blackberry. Plant wetland with willows.                                                                                                                                                                                                                                                                                                                                    |
| I.5.3           | 224           | Upland (House remains)                    | Near the house, the wetland is dominated by lady fern, creeping buttercup, and field horsetail in the emergent layer and salmonberry and Himalayan blackberry in the shrub stratum. A 3.5 ft high fence is located parallel to the channel, behind the house.<br><br>The upland consists of a house, driveway, lawn, and ornamental shrubs. At the west edge of the wetland is a mature white oak tree and horse chestnut tree. In the SE corner, there is western redbud, swordfern, creeping blackberry, ivy, and western hazelnut. Small areas of Himalayan blackberry, field morning glory, and English ivy are present in the understory of the forest. | Remove buildings, driveway, and associated fill. Regrade to smooth contours. Remove Himalayan blackberry, field morning glory, and ivy in the understory. Replant with native shade-tolerant shrub species (e.g., swordfern). Protect white oak and chestnut.<br><br>See description for Parcel 222.                                                                                                                                                                                                                                                                                            |
| I.5.3           | 225           | Wetland / Stream (Garage and shed remain) | The west portion of the property consists of a closed canopy forest of western redbud, black cottonwood, big-leaf maple, and Douglas fir. The understory is composed of Indian plum, swordfern, with a dense coverage of Himalayan blackberry, some ivy, and English holly. A house remains on upland.<br><br>Half of the wetland is managed lawn and the other half is Himalayan blackberry and red alder trees. A garage and shed are located in the wetland.                                                                                                                                                                                              | Remove structures and associated fill. Regrade to smooth contours. Control Himalayan blackberry and ivy near wetland edge. Plant shade-tolerant coniferous trees in the understory; otherwise little planting is required on this parcel.<br><br>Remove buildings and Himalayan blackberry. Plant native trees and shrubs.                                                                                                                                                                                                                                                                      |

**AGENCY REVIEW NOT FOR CONSTRUCTION**

CALL 48 HOURS BEFORE YOU DIG 1-800-424-5555

**Parametrix, Inc.**  
5808 U. Washington Blvd. NE  
Kirkland, WA 98033  
Ph: (425) 852-8800  
Quality Service Through Employee Ownership

**AGENCY REVIEW**  
 PROJECT NO.:  
 SHEET NO.:  
 DATE:  
 DRAWN BY:  
 CHECKED BY:  
 PROJECT:

**Port of Seattle**  
SEA-TAC INTERNATIONAL AIRPORT  
MILLER CREEK INSTREAM AND BUFFER ENHANCEMENTS  
  
 PROJECT NO. 1  
 SHEET 1114  
 DATE 11/11/14  
 DRAWN BY  
 CHECKED BY  
 PROJECT

**EXISTING VEGETATION & WETLAND ENHANCEMENT ACTIONS**

AR 049474

Appendix 3. Description of existing vegetation and proposed wetland and buffer enhancement actions along Miller Creek (continued).

| Sheet Number    | Parcel Number | Location                                                                 | Existing Conditions                                                                                                                                                                                                                                                                                                                                                                                                                                                                                                    | Proposed Mitigation Actions                                                                                                                                                                                                                                                                  |
|-----------------|---------------|--------------------------------------------------------------------------|------------------------------------------------------------------------------------------------------------------------------------------------------------------------------------------------------------------------------------------------------------------------------------------------------------------------------------------------------------------------------------------------------------------------------------------------------------------------------------------------------------------------|----------------------------------------------------------------------------------------------------------------------------------------------------------------------------------------------------------------------------------------------------------------------------------------------|
| 1.5.3           | 226           | Wetland / Stream (Shed remains)<br>Upland (House remains outside buffer) | The wetland area is primarily vegetated with lawn, Himalayan blackberry, field horsetail, field morning glory occur in patches and along east edge of the property. A shed is located in the wetland.<br>The upland consists of house, driveway, and lawn with ornamental shrubs.                                                                                                                                                                                                                                      | Remove buildings, driveway, and Himalayan blackberry; plant with willows.<br>Remove buildings, driveway, ornamental plants, and associated fill. Regrade to smooth contours. Plant with native trees and shrubs.                                                                             |
| 1.5.3           | 227           | Wetland / Stream<br>Upland (No structures)                               | The wetland vegetation consists of alder trees, and Himalayan blackberry.<br>Vegetation on the site consists predominantly of coniferous forest vegetation with a small area of lawn near the house and a patch of Himalayan blackberry west of the house. English ivy is present in the south central portion of the parcel.                                                                                                                                                                                          | Remove blackberry and plant additional coniferous trees to shade out blackberry.<br>Remove the Himalayan blackberry and plant the area with specified trees and shrubs. Remove English ivy in the south central portion of the parcel.                                                       |
| 1.5.3           | 228           | Wetland / Stream<br>Upland                                               | Small area of wetland in SE corner of parcel.<br>The site is generally forested; however, some areas near the house are dominated by Himalayan blackberry.                                                                                                                                                                                                                                                                                                                                                             | Plant with specified native trees and shrubs.<br>Remove Himalayan blackberry and interplant with native coniferous tree species.                                                                                                                                                             |
| 1.5.3           | 229           | Wetland / Stream<br>Upland (No structures)                               | Wetland vegetation consists of creeping buttercup, reed canarygrass, and henigrass. Black locust saplings/suckers are also present. A fence is located between the wetland and channel.<br>The small area of upland is located on the parcel and consists of grass and bare ground.                                                                                                                                                                                                                                    | Remove fence. Remove reed canarygrass and locust. Plant willow trees and shrubs.<br>Plant this small area with a shade-tolerant tree or a few shade-tolerant shrubs.                                                                                                                         |
| 1.5.3           | 230           | Wetland / Stream                                                         | A narrow fringe of palustrine emergent wetland is located near the east edge of the parcel (refer to the description of the wetland on Parcel 229).<br>Lawn and ornamental shrubs are planted around the house. Several trees are located along the channel and elsewhere. A house, garage, and concrete driveway are also present.                                                                                                                                                                                    | Remove fence and locust saplings/suckers and plant this area with willow trees and shrubs.<br>Remove buildings, driveway, and associated fill. Regrade to smooth contours. Plant with native trees and shrubs.                                                                               |
| 1.5.2 and 1.5.3 | 231           | Wetland / Stream<br>Upland (House removed)<br>Wetland / Stream           | The wetland vegetation includes watercress, common velvetgrass, and field horsetail. There are red alder saplings and some ornamentals on the west side. The east side of the wetland is lined with larger red alder, western redcedar, and a cherry tree.<br>The parcel has been graded and hydroseeded and is dominated by clover. A tulip tree is also on the site.<br>The wetland includes a western redcedar overstory and an understory of alder saplings. The ground cover is primarily native emergent plants. | Remove reed canarygrass and blackberry. Plant with willow trees and shrubs.<br>Plant entire upland area with native trees and shrubs.<br>No action is necessary on this parcel.                                                                                                              |
| 1.5.2 and 1.5.3 | 232           | Upland (House removed)<br>Wetland / Stream                               | The parcel is largely vegetated with an alder forest. The understory consists predominantly of native species including western hazelnut, Indian plum, and swordfern. Some blackberry cover is present on the south central property boundary. House is located outside buffer enhancement area.                                                                                                                                                                                                                       | Remove Himalayan blackberry in the southern portion of the site and plant the area with native trees.                                                                                                                                                                                        |
| 1.5.2           | 233           | Wetland / Stream                                                         | The wetland contains forest and emergent areas. Red alder and large black cottonwood trees are present in the wetland. In open areas, emergent wetland vegetation consists of field horsetail, Himalayan blackberry, and yellow flag iris.                                                                                                                                                                                                                                                                             | Remove Himalayan blackberry and yellow flag iris. Plant with willows and other trees and shrubs.                                                                                                                                                                                             |
| 1.5.2           | 234           | Upland (House remains)<br>Wetland / Stream<br>Upland (House remains)     | Vegetation is a mixture of lawn, ornamental shrubs, and native species (such as western hazelnut, bitter cherry, a couple of young Douglas fir). A garbage pile is located behind the house. There are two driveways on the property.<br>See description for Parcel 233.<br>This area is mostly all lawn with no other vegetation present. Uplands contain house and driveway.                                                                                                                                         | Remove garbage, buildings, driveways, concrete stairs, and associated fill. Grade to smooth contours. Remove vegetation between the house and the wetland and plant with specified native trees. Replant disturbed areas with specified trees and shrubs.<br>See description for Parcel 233. |
| 1.5.2           | 235           | Wetland / Stream                                                         | Wetland vegetation consists of soft rush, small-fruited burrhead, creeping buttercup, sawbeak sedge, and field horsetail. Some Himalayan blackberry is present along and east of Water D. There is good tree cover (red alder, black cottonwood) on the east side of Water D.                                                                                                                                                                                                                                          | Remove buildings, driveway, and associated fill. Grade to smooth contours. Plant the open area with native sun-tolerant trees and shrubs.<br>Remove driveways and foundations. Plant open areas with willow trees and shrubs.                                                                |

AGENCY REVIEW  
NOT FOR CONSTRUCTION

CALL 48 HOURS  
BEFORE YOU DIG  
1-800-424-5555

**Parametrix, Inc.**  
500BLK Washington Blvd NE  
Kirkland, WA 98033  
Ph: (425) 872-8800  
FAX: (425) 872-8801  
www.parametrix.com

PROJECT NO: 2001-001  
SHEET NO: 11  
DATE: 11/11/03

PROJECT: EXISTING VEGETATION & WETLAND ENHANCEMENT ACTIONS

CLIENT: Port of Seattle  
SEA-TAC INTERNATIONAL AIRPORT  
MILLER CREEK INSTREAM AND BUFFER ENHANCEMENTS

DATE: 11/11/03  
SHEET NO: 11  
PROJECT: EXISTING VEGETATION & WETLAND ENHANCEMENT ACTIONS

DATE: 11/11/03  
SHEET NO: 11  
PROJECT: EXISTING VEGETATION & WETLAND ENHANCEMENT ACTIONS

DATE: 11/11/03  
SHEET NO: 11  
PROJECT: EXISTING VEGETATION & WETLAND ENHANCEMENT ACTIONS

DATE: 11/11/03  
SHEET NO: 11  
PROJECT: EXISTING VEGETATION & WETLAND ENHANCEMENT ACTIONS

DATE: 11/11/03  
SHEET NO: 11  
PROJECT: EXISTING VEGETATION & WETLAND ENHANCEMENT ACTIONS

DATE: 11/11/03  
SHEET NO: 11  
PROJECT: EXISTING VEGETATION & WETLAND ENHANCEMENT ACTIONS

DATE: 11/11/03  
SHEET NO: 11  
PROJECT: EXISTING VEGETATION & WETLAND ENHANCEMENT ACTIONS

DATE: 11/11/03  
SHEET NO: 11  
PROJECT: EXISTING VEGETATION & WETLAND ENHANCEMENT ACTIONS

DATE: 11/11/03  
SHEET NO: 11  
PROJECT: EXISTING VEGETATION & WETLAND ENHANCEMENT ACTIONS

DATE: 11/11/03  
SHEET NO: 11  
PROJECT: EXISTING VEGETATION & WETLAND ENHANCEMENT ACTIONS

DATE: 11/11/03  
SHEET NO: 11  
PROJECT: EXISTING VEGETATION & WETLAND ENHANCEMENT ACTIONS

Appendix B. Description of existing vegetation and proposed wetland and buffer enhancement actions along Miller Creek (continued).

| Sheet Number    | Parcel Number | Location                       | Existing Conditions                                                                                                                                                                                                                                                                                                                                                                                                                 | Proposed Mitigation Actions                                                                                                                                                                                                                                 |
|-----------------|---------------|--------------------------------|-------------------------------------------------------------------------------------------------------------------------------------------------------------------------------------------------------------------------------------------------------------------------------------------------------------------------------------------------------------------------------------------------------------------------------------|-------------------------------------------------------------------------------------------------------------------------------------------------------------------------------------------------------------------------------------------------------------|
| 1.5.2           | 236           | Upland<br>(House removed)      | This area is primarily lawn with several large western redcedars are present on the north side of the parcel. A large horse chestnut is also present on the parcel. A driveway and foundation remain.                                                                                                                                                                                                                               | Remove driveways, foundations, and associated fill. Protect and preserve cedars. Grade to smooth contours. Plant the open area with specified native sun-tolerant trees and shrubs.                                                                         |
|                 |               | Wetland / Stream               | The wetland vegetation consists of common velvetgrass, field horsetail, and lady fern. Some Himalayan blackberry and field morning glory is present near Water D.                                                                                                                                                                                                                                                                   | Remove Himalayan blackberry and field morning glory. Plant open and disturbed areas with willow trees and shrubs.                                                                                                                                           |
| 1.5.2           | 237           | Upland<br>(Structures remain)  | This area is predominantly lawn with scattered trees including Colorado blue spruce, mature western redcedar, and fruit trees (cherry and apple). A house, garage, and driveway remain on the east.                                                                                                                                                                                                                                 | Remove structures, driveway, and associated fill. Grade to smooth contours. Plant lawn area with sun-tolerant coniferous tree species.                                                                                                                      |
|                 |               | Wetland / Stream               | The wetland vegetation consists of wet meadow areas on the south side and red alder/black cottonwood forest, on the north side (near the road). In the open areas, some blackberry is present.                                                                                                                                                                                                                                      | Remove Himalayan blackberry. Plant open areas with willow and underplant western redcedar trees.                                                                                                                                                            |
| 1.5.2           | 238           | Upland                         | The majority of the upland area consists of relatively undisturbed Douglas fir and western redcedar forest. Understory consists of salal, Indian plum, western hazelnut, and swordfern. A small area of English ivy is located in the eastern portion of the parcel. Open, hydroseeded area remains on former home site, in the central portion of the parcel. Red alder saplings are growing in the cleared and hydroseeded areas. | Remove Himalayan blackberry and English ivy. Plant the open disturbed and open areas with native sun-tolerant trees.                                                                                                                                        |
|                 |               | Wetland / Stream               | Himalayan blackberry, field morning glory, climbing nightshade, and field horsetail are dominant in the wetland located near the east side of the parcel.                                                                                                                                                                                                                                                                           | Remove Himalayan blackberry field morning glory, climbing nightshade. Plant disturbed areas with red alder, Sitka spruce, and black cottonwood.                                                                                                             |
| 1.5.2           | 239           | Upland<br>(Structures remain)  | A house, garage, and shed remain on the parcel. Lawn and ornamental shrubs are present near the house. Large pines and hemlock trees are also present on the site.                                                                                                                                                                                                                                                                  | Remove building, driveway, and associated fill. Grade to smooth contours. Protect pines and hemlocks. Plant disturbed and open areas with native sun-tolerant coniferous trees. Remove ornamental shrubs and replant the area with vine maple.              |
|                 |               | Wetland / Stream               | This wetland contains some mature red alder and black cottonwood trees. Various grasses, soft rush, and field horsetail occur in the understory.                                                                                                                                                                                                                                                                                    | Remove Himalayan blackberry. Plant disturbed areas with western redcedar. Interplant western redcedar in forested areas.                                                                                                                                    |
| 1.5.2           | 240           | Upland<br>(Structures removed) | Vegetation on the site includes grasses on the old house pad with Pacific madrone, red alder, cherry laurel, and western redcedar located around the perimeter of the house. Himalayan blackberry occurs in open areas, between the house and the wetland.                                                                                                                                                                          | Remove Himalayan blackberry and field morning glory. Plant open and disturbed areas with specified native trees and shrubs.                                                                                                                                 |
|                 |               | Wetland / Stream               | The wetland vegetation includes an overstory of red alder and understory of Himalayan blackberry, field morning glory, and bentgrass. An approximately 30-ft segment of Water D has been placed in an 18-inch culvert, at the southern portion of the site.                                                                                                                                                                         | Remove Himalayan blackberry and field morning glory. Daylight Water D by removing the 30-ft-long culvert. Stabilize the banks by using bioengineering techniques and replanting with willow stakes. Plant disturbed areas with western redcedar and willow. |
| 1.5.2           | 241           | Upland<br>(Shed remains)       | Upland portion of the parcel is grassland. Ornamental trees and shrubs occur along the perimeter. Himalayan blackberry occurs in patches.                                                                                                                                                                                                                                                                                           | Remove driveway and Himalayan blackberry. Plant the open areas with native tree and shrub species.                                                                                                                                                          |
|                 |               | Wetland / Stream               | This area has a young red alder overstory with a thick Himalayan blackberry and stinging nettle understory. Field morning glory is also present.                                                                                                                                                                                                                                                                                    | Remove blackberry and replant disturbed areas with native trees and shrubs.                                                                                                                                                                                 |
| 1.5.1 and 1.5.2 | 242           | Upland                         | This area is largely grassland. Several large Douglas fir, cherry laurel, and pine trees occur near the north property line. Hazelnut and fir trees are present around the perimeter of the lot. An area of mounded soil and concrete blocks is present, behind the former house pad.                                                                                                                                               | Remove blackberry and field morning glory. Remove concrete blocks and block fragments. Remove cherry laurel and plant disturbed and open areas with native trees and shrubs.                                                                                |
|                 |               | Wetland / Stream               | A narrow fringe of wetland is located on this parcel and associated with Miller Creek. The wetland contains creeping buttercup, field horsetail, and jewelweed. Common tansy and western hazelnut are located immediately adjacent to the wetland edge. Areas of blackberry, climbing nightshade, and yellow flag iris are located near and in the wetland.                                                                         | Control blackberry, yellow flag iris, and climbing nightshade. Plant native shrub species near the wetland.                                                                                                                                                 |
| 1.5.1 and 1.5.2 | 243           | Upland<br>(Structures removed) | Vegetation on this site is largely grass. Several trees are present near the perimeter, and cherry laurel and other ornamental species are also present.                                                                                                                                                                                                                                                                            | Plant open areas with native trees and shrubs.                                                                                                                                                                                                              |
|                 |               | Wetland / Stream               | The wetland is a narrow fringe located immediately adjacent to the channel. Vegetation in the channel includes Pacific willow, creeping buttercup, and field horsetail. A few large black cottonwood trees are located adjacent to the channel. An approximately 75-ft segment of Water D, between the driveway and outbuildings, has been placed in a cement culvert.                                                              | Remove Water D from the culvert. Restore the banks of Water D by using BMP's, bioengineering techniques, and planting willow stakes.                                                                                                                        |

AGENCY REVIEW  
NOT FOR CONSTRUCTION

CALL 48 HOURS  
BEFORE YOU DIG  
1 800-424-5555

**Parametrix, Inc.**  
5808 11<sup>th</sup> Washington Blvd NE  
Bellevue, WA 98003  
Tel: (206) 835-8800  
Fax: (206) 835-8801  
www.parametrix.com  
Quality Service Through Employee Ownership  
P. 1 EN01

PROJECT NUMBER: 1000000000  
PROJECT NAME: MILLER CREEK INSTREAM AND BUFFER ENHANCEMENTS  
SHEET NO: 1000000000

DATE: 10/11/11  
SCALE: AS SHOWN  
PROJECT LOCATION: MILLER CREEK INSTREAM AND BUFFER ENHANCEMENTS

DESIGNER: [Blank]  
CHECKED BY: [Blank]  
DATE: [Blank]

APPROVED BY: [Blank]  
DATE: [Blank]

PROJECT NO: 1000000000  
SHEET NO: 1000000000

PROJECT NAME: MILLER CREEK INSTREAM AND BUFFER ENHANCEMENTS  
SHEET NO: 1000000000

PROJECT LOCATION: MILLER CREEK INSTREAM AND BUFFER ENHANCEMENTS  
SHEET NO: 1000000000

PROJECT NO: 1000000000  
SHEET NO: 1000000000

PROJECT NAME: MILLER CREEK INSTREAM AND BUFFER ENHANCEMENTS  
SHEET NO: 1000000000

PROJECT LOCATION: MILLER CREEK INSTREAM AND BUFFER ENHANCEMENTS  
SHEET NO: 1000000000

PROJECT NO: 1000000000  
SHEET NO: 1000000000

PROJECT NAME: MILLER CREEK INSTREAM AND BUFFER ENHANCEMENTS  
SHEET NO: 1000000000

PROJECT LOCATION: MILLER CREEK INSTREAM AND BUFFER ENHANCEMENTS  
SHEET NO: 1000000000

Port of Seattle  
SEA TAC INTERNATIONAL AIRPORT  
MILLER CREEK INSTREAM AND BUFFER ENHANCEMENTS  
EXISTING VEGETATION &  
WETLAND ENHANCEMENT ACTIONS



**Appendix B. Description of existing vegetation and proposed wetland and buffer enhancement actions along Miller Creek (continued).**

| Sheet Number    | Parcel Number | Location                                           | Existing Conditions                                                                                                                                                                                                                                                                                                                                                                                                   | Proposed Mitigation Actions                                                                                                                                                                                                                                                                                                                                       |
|-----------------|---------------|----------------------------------------------------|-----------------------------------------------------------------------------------------------------------------------------------------------------------------------------------------------------------------------------------------------------------------------------------------------------------------------------------------------------------------------------------------------------------------------|-------------------------------------------------------------------------------------------------------------------------------------------------------------------------------------------------------------------------------------------------------------------------------------------------------------------------------------------------------------------|
| 1.5.1 and 1.5.2 | 243           | Upland<br>(Structures remain)                      | A gravel driveway occurs within 10 ft of the stream. Patches of native and non-native trees are present in a grassy meadow. Pacific willows are located next to the stream. Small patches of blackberry are becoming established in the meadow. A house and several outbuildings are still present.                                                                                                                   | Remove structures and the gravel driveway after access is no longer needed. Remove patches of blackberry and plant the disturbed areas and the open meadow with native trees and shrubs.                                                                                                                                                                          |
| 1.5.1 and 1.5.2 | 244           | Upland<br>(Structures present)                     | Grasses dominate this area with areas of Himalayan blackberry and field morning glory becoming established. Cattail and other wetland plants are becoming established on recently graded and compacted areas where residential structures were recently removed. Several fruit trees are also present. There is an existing gravel driveway and several mounds of gravel.                                             | Remove driveway, house, gravel, and associated fill. Remove blackberry and field morning glory, and plant with native trees and shrubs.                                                                                                                                                                                                                           |
| 1.5.4           | 254           | Wetland / Stream                                   | Creeping buttercup is dominant in the wetland, with some Himalayan blackberry on the south and north sides. A Douglas fir on the east and a western redcedar on the west border the area.                                                                                                                                                                                                                             | Remove Himalayan blackberry. Plant trees (western redcedar) in the wetland.                                                                                                                                                                                                                                                                                       |
| 1.5.4           | 261           | Upland<br>(Structures removed)<br>Wetland / Stream | The area is vegetated with grasses and scattered trees (western hemlock, black cottonwood, and several fruit trees).<br>The wetland vegetation consists of creeping buttercup, field horsetail, and skunk cabbage, but a few red alder are also present. Blackberry is also present, especially along the perimeter of the wetland. A driveway has been constructed in the wetland, at the north edge of the wetland. | Remove buildings, driveway, and associated fill. Grade to smooth contours. Plant disturbed areas with trees and shrubs.                                                                                                                                                                                                                                           |
|                 |               | Upland<br>(Structures removed)                     | Most of the area is grass. Coniferous trees are present on the south side, with big-leaf maple, western redcedar, and Douglas fir on the north side. Red alder saplings are becoming established on the parcel.                                                                                                                                                                                                       | Remove Himalayan blackberry from wetland. Remove the driveway on the north side, between Parcel 254R and Parcel 261 and on the south side of the wetland between Parcels 261 and 218. Plant the open and disturbed areas with willow trees and shrubs.<br>Protect existing conifers and big-leaf maple. Plant sun-tolerant trees and shrubs in open meadow areas. |

AGENCY REVIEW  
NOT FOR CONSTRUCTION

CALL 48 HOURS  
BEFORE DRIVING  
1-800-424-5555

**Parametrix, Inc.**

5808 1<sup>st</sup> Washington Blvd NE  
Bellevue, WA 98003  
PH: (206) 837-8800

PROJECT: MILLER CREEK INSTREAM AND BUFFER ENHANCEMENTS  
SHEET TITLE: EXISTING VEGETATION & WETLAND ENHANCEMENT ACTIONS

DATE: 11/15/2011  
DRAWN BY: J. BURTON  
CHECKED BY: J. BURTON  
DATE: 11/15/2011

SCALE: AS SHOWN  
NOVEMBER 2011  
PROJECT: MILLER CREEK INSTREAM AND BUFFER ENHANCEMENTS  
SHEET TITLE: EXISTING VEGETATION & WETLAND ENHANCEMENT ACTIONS

DATE: 11/15/2011  
DRAWN BY: J. BURTON  
CHECKED BY: J. BURTON  
DATE: 11/15/2011

DATE: 11/15/2011  
DRAWN BY: J. BURTON  
CHECKED BY: J. BURTON  
DATE: 11/15/2011

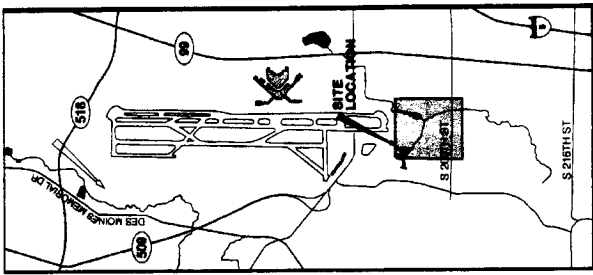
DATE: 11/15/2011  
DRAWN BY: J. BURTON  
CHECKED BY: J. BURTON  
DATE: 11/15/2011

DATE: 11/15/2011  
DRAWN BY: J. BURTON  
CHECKED BY: J. BURTON  
DATE: 11/15/2011

DATE: 11/15/2011  
DRAWN BY: J. BURTON  
CHECKED BY: J. BURTON  
DATE: 11/15/2011



VICINITY MAP



LEGEND

- EXISTING CONTOUR
- EXISTING GRADE (SECTION)
- CHAIN LINK FENCE
- WETLAND BOUNDARY
- EXISTING FLOODPLAIN BOUNDARY
- PROPOSED FLOODPLAIN BUFFER
- LIMIT OF 100 FT RIPARIAN BUFFER
- WATERBODY
- BOUNDARY OF IWS

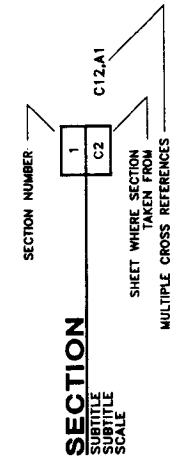
GENERAL ABBREVIATIONS

- DIA DIAMETER
- E EAST/CASTING
- CO COORDINATE
- GAL GALLON
- N NORTH/NORTHING
- NTS NOT TO SCALE
- O.C. ON CENTER
- FT FEET
- S.F. SQUARE FEET
- SEWER SANITARY SEWER
- TYP. TYPICAL

GENERAL LEGEND

DRAWING TITLE:

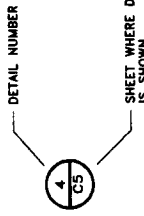
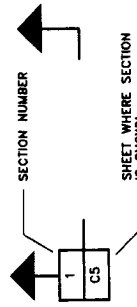
**PLAN**  
 SUBTITLE  
 SUBTITLE  
 SCALE



**SECTION**  
 SUBTITLE  
 SUBTITLE  
 SCALE

**DETAIL**  
 SUBTITLE  
 SUBTITLE  
 SCALE

REFERENCE SYMBOL:

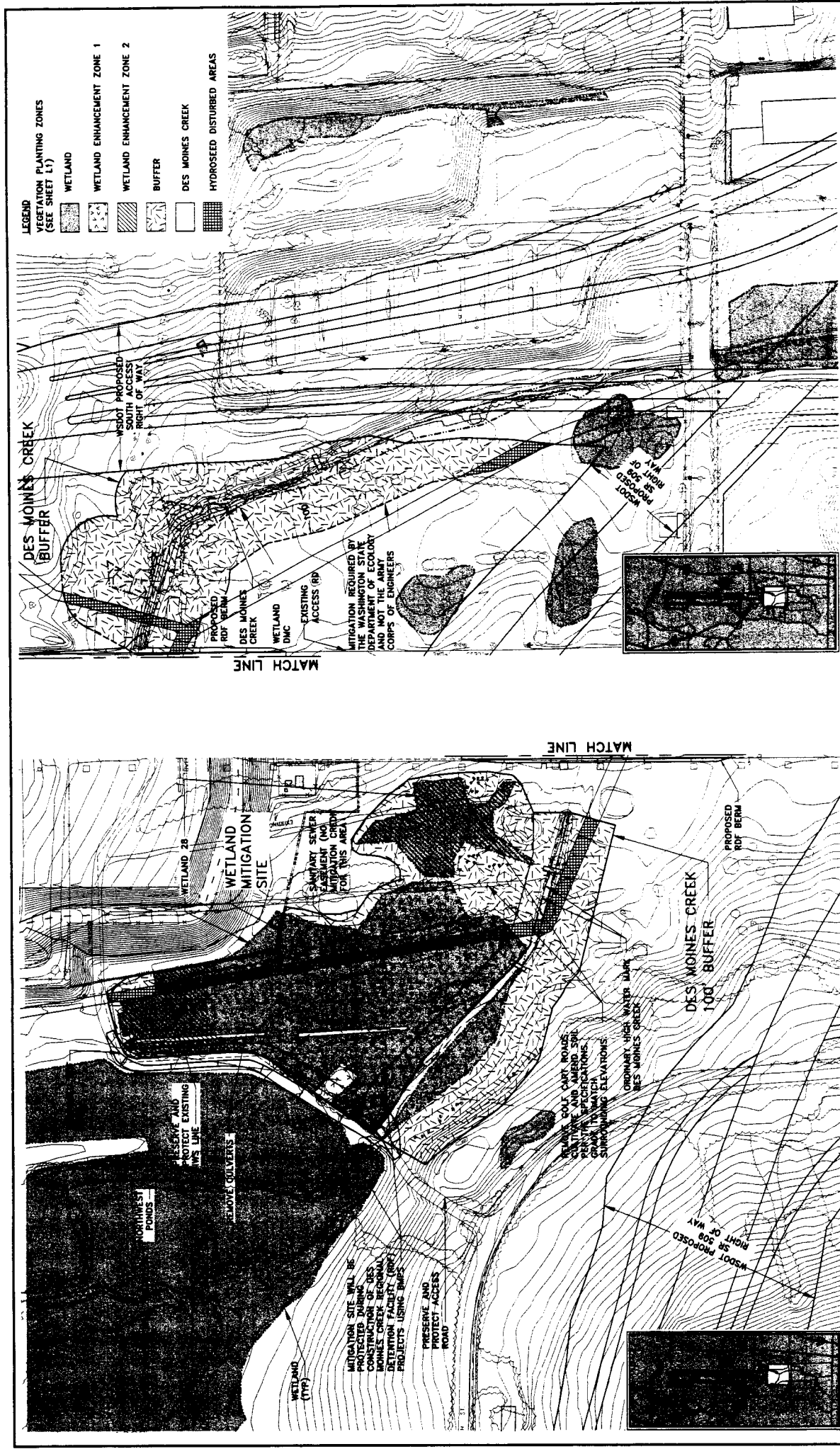


GENERAL NOTES

- CALL "DIG-SAFE" (1-800-425-5555) PRIOR TO COMMENCING ANY GRADING OR EXCAVATION WORK ON THE SITE.
- INSTALLATION OF TEMPORARY EROSION AND SEDIMENT CONTROLS SHALL BE COMPLETED PRIOR TO SITE WORK.

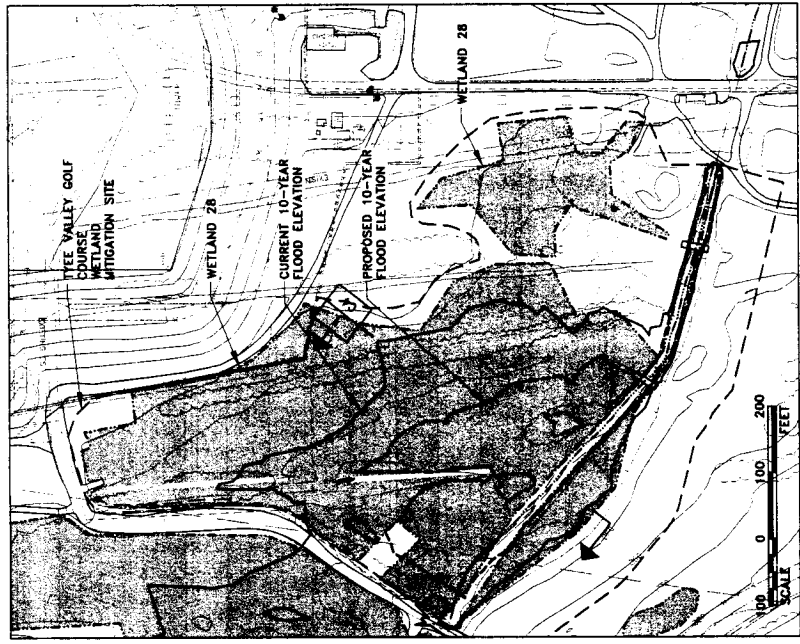
AGENCY REVIEW NOT FOR CONSTRUCTION

|                                                                                                                                                             |                                                                                         |                                                                                     |                                                                                    |
|-------------------------------------------------------------------------------------------------------------------------------------------------------------|-----------------------------------------------------------------------------------------|-------------------------------------------------------------------------------------|------------------------------------------------------------------------------------|
| <b>Parametrix, Inc.</b><br>5808 Lt. Washington Blvd. NE<br>Kirkland, WA 98033<br>Ph: (425) 822-8880                                                         |                                                                                         | DATE: 11/19/20 FILENAME: 2012R2C1                                                   |                                                                                    |
| CALL 48 HOURS BEFORE YOU DIG 1-800-424-5555                                                                                                                 | S.C. & S.C. UTILTY, URBAN<br>1277 20th St<br>SE<br>Bellevue, WA 98004<br>(206) 461-1234 | PROJECT NUMBER:<br>SHEET NO:<br>DATE:<br>DRAWN BY:<br>CHECKED BY:<br>PROJECT TITLE: | <b>Parametrix, Inc.</b><br>2012R2C1<br>SHEET NO. 5714-XXXY-C1<br><b>APPENDIX C</b> |
| <b>Parametrix, Inc.</b><br>SEA-TAC INTERNATIONAL AIRPORT<br>TYEE VALLEY GOLF COURSE WETLAND MITIGATION<br>VICINITY MAP, SYMBOLS, NOTES<br>AND ABBREVIATIONS |                                                                                         |                                                                                     |                                                                                    |

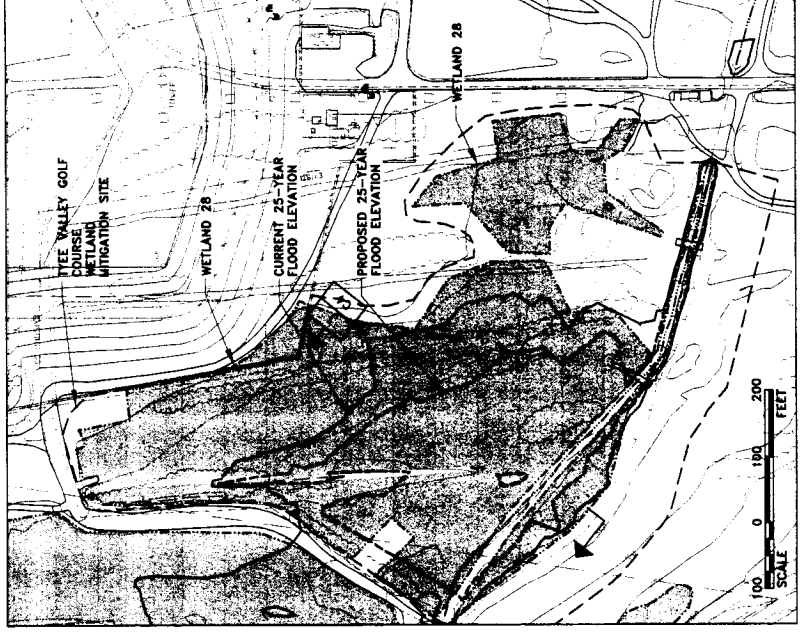


|                                                                                                                                                                              |                    |                                                                                                  |                                                   |
|------------------------------------------------------------------------------------------------------------------------------------------------------------------------------|--------------------|--------------------------------------------------------------------------------------------------|---------------------------------------------------|
| <b>Parametrix, Inc.</b><br>5808 Lk. Washington Blvd. NE<br>Bellevue, WA 98003<br>P: (206) 835-8800<br>F: (206) 835-8801<br><i>Quality Service Through Employee Ownership</i> |                    | DATE: 11/19/04<br>DRAWN: KRM<br>CHECKED: JLB<br>PROJECT NO.: 281282C2<br>SHEET NO.: 5714-XXXX-C2 |                                                   |
| <b>AGENCY REVIEW</b><br><b>NOT FOR CONSTRUCTION</b>                                                                                                                          |                    |                                                                                                  |                                                   |
| <b>Part of Seattle SEA-TAC INTERNATIONAL AIRPORT TYPE VALLEY GOLF COURSE WETLAND MITIGATION PLANTING PLAN</b>                                                                |                    |                                                                                                  |                                                   |
| CALL 48 HOURS BEFORE 10U 555<br>1-800-424-5555                                                                                                                               | SCALE<br>1" = 100' | ELEVATIONS<br>1" = 10'                                                                           | APP'X<br>SHEET NO.<br>TOTAL SHEETS<br>PROJECT NO. |

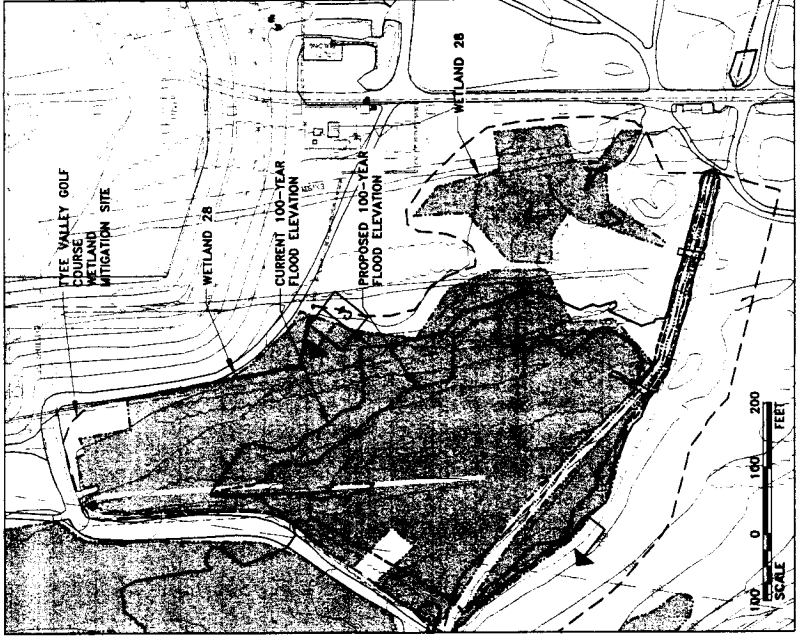
AR 049480



**PLAN**  
 EXTENT OF CURRENT  
 AND PROPOSED  
 10-YEAR FLOOD LIMITS



**PLAN**  
 EXTENT OF  
 CURRENT  
 AND PROPOSED  
 25-YEAR FLOOD LIMITS



**PLAN**  
 EXTENT OF CURRENT  
 AND PROPOSED  
 100-YEAR FLOOD LIMITS

**LEGEND:**

- CURRENT WATER ELEVATION
- - - PROPOSED WATER ELEVATION AFTER DES MOINES CREEK RECONSTRUCTION (BY OTHERS)
- PROPOSED TYEE VALLEY GOLF COURSE WETLAND ENHANCEMENT
- TYEE VALLEY GOLF COURSE WETLAND ENHANCEMENT AREA

SOURCE: DES MOINES CREEK BASIN PLANNING COMMITTEE

CALL US NOW!  
 BEFORE YOU DIG.  
 1-800-424-5555

**Parametrix, Inc.**  
 5808 1st. Washington Blvd. NE  
 Kirkland, WA 98033  
 Ph: (425) 822-8800

FOR THE CITY OF  
 BEA-TAC INTERNATIONAL AIRPORT

TYEE VALLEY GOLF COURSE  
 WETLAND MITIGATION

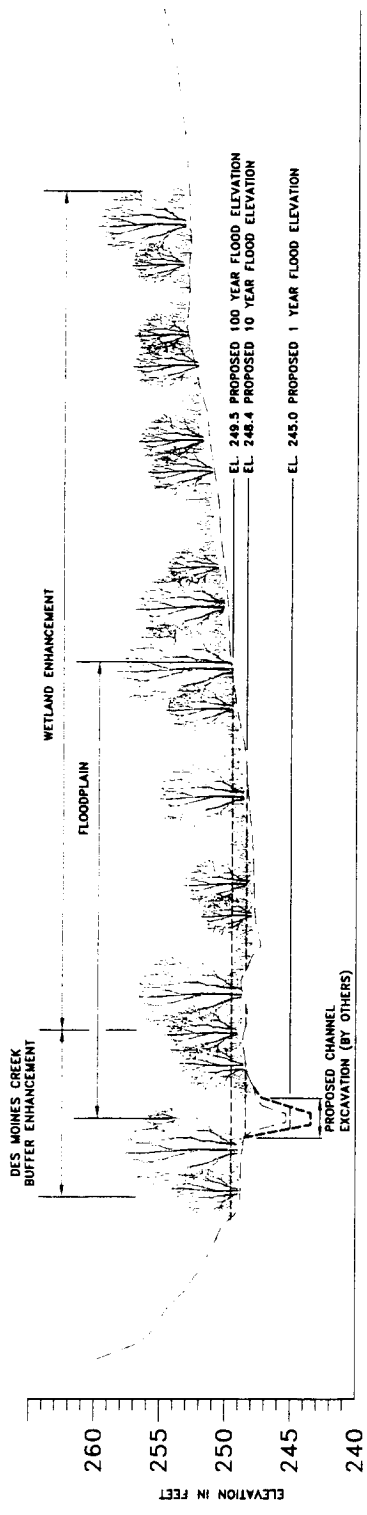
PROJECT NO. 291282C3  
 SHEET NO. 291282C3

| REVISIONS |      |    |             |
|-----------|------|----|-------------|
| NO.       | DATE | BY | DESCRIPTION |
|           |      |    |             |
|           |      |    |             |
|           |      |    |             |
|           |      |    |             |

Part of Seattle  
 BEA-TAC INTERNATIONAL AIRPORT  
 TYEE VALLEY GOLF COURSE  
 WETLAND MITIGATION

PROJECT NO. 291282C3  
 SHEET NO. 291282C3

AGENCY REVIEW  
 NOT FOR CONSTRUCTION



**SECTION**  
 1 OF HYDRAULICS AND TEE GOLF  
 COURSE WETLAND MITIGATION SITE  
 HORIZ. SCALE: 1" = 40'  
 VERT. SCALE: 1" = 5'

|    |
|----|
| 1  |
| C3 |

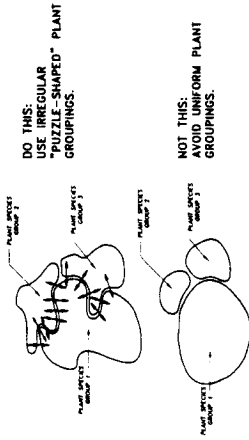
SOURCE: DES MOINES CREEK BASIN PLANNING COMMITTEE

AGENCY REVIEW  
 NOT FOR CONSTRUCTION

| CALL 48 HOURS<br>BEFORE CONSTRUCTION<br>1-800-454-5555  | <b>Parametrix, Inc.</b><br>9808 Lk. Washington Blvd. NE<br>Bellevue, WA 98004<br>PH: (425) 822-8800<br>Fax: (425) 822-8801<br>Quality Service Through Employee Ownership | DATE: 10/31/01<br>FILENAME: 29129234<br>10/25/01 | REVISIONS<br><table border="1"> <tr> <th>NO.</th> <th>DATE</th> <th>DESCRIPTION</th> </tr> <tr> <td> </td> <td> </td> <td> </td> </tr> <tr> <td> </td> <td> </td> <td> </td> </tr> <tr> <td> </td> <td> </td> <td> </td> </tr> <tr> <td> </td> <td> </td> <td> </td> </tr> <tr> <td> </td> <td> </td> <td> </td> </tr> </table> | NO. | DATE | DESCRIPTION |  |  |  |  |  |  |  |  |  |  |  |  |  |  |  | Part of Seattle<br><b>SEA-TAC INTERNATIONAL AIRPORT</b><br>TEE VALLEY GOLF COURSE<br>WETLAND MITIGATION<br><b>CROSS SECTION OF MITIGATION AREA</b><br>SHEET NO. 29129234<br>OF 29129234<br>5714-DX1Y-C4<br>APPENDIX C |
|---------------------------------------------------------|--------------------------------------------------------------------------------------------------------------------------------------------------------------------------|--------------------------------------------------|---------------------------------------------------------------------------------------------------------------------------------------------------------------------------------------------------------------------------------------------------------------------------------------------------------------------------------|-----|------|-------------|--|--|--|--|--|--|--|--|--|--|--|--|--|--|--|-----------------------------------------------------------------------------------------------------------------------------------------------------------------------------------------------------------------------|
|                                                         |                                                                                                                                                                          |                                                  |                                                                                                                                                                                                                                                                                                                                 | NO. | DATE | DESCRIPTION |  |  |  |  |  |  |  |  |  |  |  |  |  |  |  |                                                                                                                                                                                                                       |
|                                                         |                                                                                                                                                                          |                                                  |                                                                                                                                                                                                                                                                                                                                 |     |      |             |  |  |  |  |  |  |  |  |  |  |  |  |  |  |  |                                                                                                                                                                                                                       |
|                                                         |                                                                                                                                                                          |                                                  |                                                                                                                                                                                                                                                                                                                                 |     |      |             |  |  |  |  |  |  |  |  |  |  |  |  |  |  |  |                                                                                                                                                                                                                       |
|                                                         |                                                                                                                                                                          |                                                  |                                                                                                                                                                                                                                                                                                                                 |     |      |             |  |  |  |  |  |  |  |  |  |  |  |  |  |  |  |                                                                                                                                                                                                                       |
|                                                         |                                                                                                                                                                          |                                                  |                                                                                                                                                                                                                                                                                                                                 |     |      |             |  |  |  |  |  |  |  |  |  |  |  |  |  |  |  |                                                                                                                                                                                                                       |
|                                                         |                                                                                                                                                                          |                                                  |                                                                                                                                                                                                                                                                                                                                 |     |      |             |  |  |  |  |  |  |  |  |  |  |  |  |  |  |  |                                                                                                                                                                                                                       |
| ONE INCH AT FULL SCALE<br>1" = 200' SCALE (APPROXIMATE) |                                                                                                                                                                          |                                                  |                                                                                                                                                                                                                                                                                                                                 |     |      |             |  |  |  |  |  |  |  |  |  |  |  |  |  |  |  |                                                                                                                                                                                                                       |

**NOTES:**

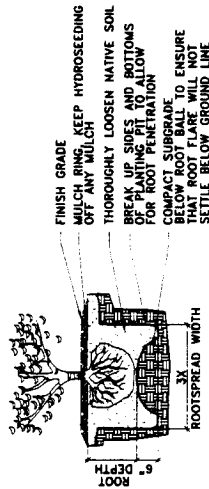
1. PRESERVE AND PROTECT ALL TREES AND SHRUBS NOT DESIGNATED FOR REMOVAL. PROVIDE, ERECT, AND MAINTAIN BARRICADES NECESSARY TO PREVENT ACCESS TO AREA WITHIN DRIP LINES OF EXISTING TREES. ALLOW NO VEHICULAR AND PEDESTRIAN TRAFFIC, OR STACKING AND/OR STORAGE OF CONSTRUCTION MATERIALS WITHIN BARRICADES.
2. CONTRACTOR SHALL LAY OUT A 10,000 S.F. TEST PLOT, IN WHICH THE POSITIONS OF ALL PLANTS SHALL BE STAKED WITH FLAGS THAT ARE COLOR CODED TO REPRESENT SPECIFIC SPECIES. LAYOUT SHALL BE INSPECTED AND APPROVED BY ENGINEER PRIOR TO COMMENCEMENT OF PLANTING. APPROVED STAKING SHALL SERVE AS THE PLANT LAYOUT STANDARD FOR THE REMAINDER OF THE PLANTING AREA.
3. SHRUB MASSES SHALL CONSIST OF MULTIPLE SINGLE-SPECIES GROUPS (SEE DETAIL 1). CONTRACTOR SHALL ENSURE THAT THESE GROUPS HAVE A VARIETY OF SIZES AND SHAPES. GROUPS MUST BE PLANTED WITH A VARIETY OF SPECIES. SEE PLANTING SCHEDULE FOR NUMBERS OF PLANTS IN SINGLE-SPECIES GROUPS.
4. CONTRACTOR SHALL COMPLY WITH ARCHAEOLOGICAL MONITORING REQUIREMENTS, AND RESTRICTIONS RESULTING FROM CONTACT WITH ARCHAEOLOGICALLY SIGNIFICANT OBJECTS (SEE SPECIFICATIONS).
5. CONTRACTOR SHALL HYDROSEED ALL AREAS DISTURBED BY WORK, USING HERBACEOUS WETLAND SEED MIX (SEE SPECIFICATIONS). RE-SEED ALL AREAS THAT ARE DISTURBED BY SUBSEQUENT WORK. KEEP HYDROSEEDING OFF ANY MULCH CIRCLES.
6. AN AUTOMATIC IRRIGATION SYSTEM WILL BE PROVIDED FOR ALL PLANTING AREAS.



**DETAIL 1**  
SHAPES OF PLANTING MASSES  
(TYP)

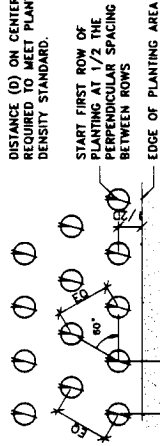
| Symbol                                                    | Botanical Name                          | Site          | Density (Plants Per Acre) | Condition / Remarks                                                                                                                                                                                         |
|-----------------------------------------------------------|-----------------------------------------|---------------|---------------------------|-------------------------------------------------------------------------------------------------------------------------------------------------------------------------------------------------------------|
| [Symbol]                                                  | <b>Wetland Enhancement Zone 1</b>       |               |                           |                                                                                                                                                                                                             |
|                                                           | <b>SHRUBS</b>                           |               |                           |                                                                                                                                                                                                             |
|                                                           | <i>Salix hookeriana</i> /Hookers willow | 1 gal./Stakes | 3,375                     | - IN CONTAINERS / ROOTING TO SIDES AND BOTTOM OF CONTAINERS. LIVE STAKES SHALL MIN. OF 10 VIABLE BUDS ON EACH STAKE. 3-4 BUDS SHALL BE BELOW GRADE.<br>- LOCATE PLANTS IN SINGLE-SPECIES GROUPS OF 7 TO 12. |
|                                                           | <i>Salix serotina</i> /Silka willow     | 1 gal./Stakes |                           |                                                                                                                                                                                                             |
| <i>Spiraea douglasii</i> /Hardhack spiraea                | 1 gal.                                  |               |                           |                                                                                                                                                                                                             |
| <i>Salix lucida</i> ssp. <i>lasandera</i> /Pacific willow | 1 gal./Stakes                           |               |                           |                                                                                                                                                                                                             |
| [Symbol]                                                  | <b>Wetland Enhancement Zone 2</b>       |               |                           |                                                                                                                                                                                                             |
|                                                           | <b>SHRUBS</b>                           |               |                           |                                                                                                                                                                                                             |
|                                                           | <i>Salix rostrata</i> /Scoulers willow  | 1 gal.        | 3,375                     | - IN CONTAINERS / ROOTING TO SIDES AND BOTTOM OF CONTAINERS. LIVE STAKES SHALL MIN. OF 10 VIABLE BUDS ON EACH STAKE. 3-4 BUDS SHALL BE BELOW GRADE.<br>- LOCATE PLANTS IN SINGLE-SPECIES GROUPS OF 7 TO 12. |
| <i>Physocarpus opulifolius</i> /Pacific ninebark          | 1 gal.                                  |               |                           |                                                                                                                                                                                                             |
| <i>Rosa pratincola</i> /Clustered wildrose                | 1 gal.                                  |               |                           |                                                                                                                                                                                                             |
| [Symbol]                                                  | <b>Buffer Planting</b>                  |               |                           |                                                                                                                                                                                                             |
|                                                           | <b>TREES</b>                            |               | 280                       | - IN CONTAINERS / ROOTING TO SIDES AND BOTTOM OF CONTAINERS. LIVE STAKES SHALL MIN. OF 10 VIABLE BUDS ON EACH STAKE. 3-4 BUDS SHALL BE BELOW GRADE.<br>- LOCATE PLANTS IN SINGLE-SPECIES GROUPS OF 7 TO 12. |
| <i>Thuja plicata</i> /Western redcedar *                  | 1 gal.                                  | 2,100         |                           |                                                                                                                                                                                                             |
| <i>Amar rubra</i> /Red alder                              | 1 gal.                                  |               |                           |                                                                                                                                                                                                             |
| <b>SHRUBS</b>                                             |                                         |               |                           |                                                                                                                                                                                                             |
| <i>Populus trichocarpa</i> /Black cottonwood              | 1 gal./Stakes                           |               |                           |                                                                                                                                                                                                             |
| <i>Acer circinosum</i> /Vine maple                        | 1 gal.                                  |               |                           |                                                                                                                                                                                                             |
| <i>Rosa milniana</i> /Noctika rose                        | 1 gal.                                  |               |                           |                                                                                                                                                                                                             |

\* Western redcedar will be planted in a second planting phase, to follow year-3 monitoring. These plants shall be located by the wetland biologist in locations where partial shade and favorable soil moisture is present.



**DETAIL 2**  
TREE AND SHRUB PLANTING  
(TYP)

**NOTE:**  
ALL SHRUB SPACING SHALL BE EQUIDISTANT UNLESS OTHERWISE SPECIFIED  
DISTANCE (D) ON CENTER AS REQUIRED TO MEET PLANT DENSITY STANDARD.



**DETAIL 3**  
TRIANGULAR SHRUB SPACING  
(TYP)

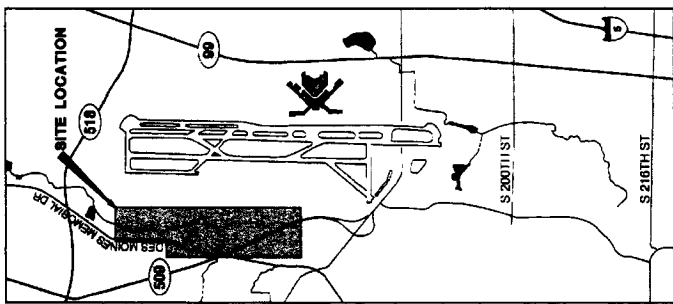
**AGENCY REVIEW**  
**NOT FOR CONSTRUCTION**

|                                                                                                     |                    |                                                                                                          |                    |
|-----------------------------------------------------------------------------------------------------|--------------------|----------------------------------------------------------------------------------------------------------|--------------------|
| <b>Parametrix, Inc.</b><br>5808 Lt. Washington Blvd. NE<br>Kirkland, WA 98033<br>Ph: (425) 822-8800 |                    | Part of Seattle<br><b>SEA-TAC INTERNATIONAL AIRPORT</b><br>TYEE VALLEY GOLF COURSE<br>WETLAND MITIGATION |                    |
| CALL 48 HOURS BEFORE YOU DIG<br>1-800-474-6555                                                      | REVISED BY<br>DATE | DRAWN BY<br>DATE                                                                                         | CHECKED BY<br>DATE |
| QUALITY SERVICE THROUGH EMPLOYEE DIVERSITY                                                          |                    | PROJECT NO. 201282L1<br>SHEET NO. 5714-XXVY-L1                                                           |                    |





**VICINITY MAP**



**LEGEND**

- CULVERT
- WATER BODY
- WETLAND BOUNDARY
- EXISTING CONTOUR (MAJOR)
- EXISTING CONTOUR (MINOR)
- STREAM CENTERLINE AND STATIONING
- PARCEL BOUNDARY
- 265
- WETLAND
- RIPARIAN AND WETLAND PLANTING ZONE
- NATIVE SUBGRADE
- UPLAND BUFFER PLANTING ZONE
- STORMWATER POND
- TEMPORARY CONSTRUCTION BOUNDARY
- PERMANENT IMPACT BOUNDARY
- WETLAND AND RIPARIAN BUFFER

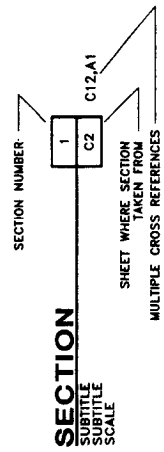
**CONSTRUCTION AND RESTORATION NOTES:**

1. THE ENGINEER SHALL IDENTIFY AREAS NOT TO BE DISTURBED. THESE AREAS SHALL BE PROTECTED WITH ORANGE BARRIER FENCE, SEDIMENT FENCE, OR OTHER BMPs DESIGNED TO PREVENT SEDIMENT RUNOFF OR VEGETATION DISTURBANCE.
2. POTENTIAL TEMPORARY WETLAND IMPACTS FROM CONSTRUCTION ARE SHOWN ON SHEETS C2 THROUGH C7. THE POTENTIAL TEMPORARY IMPACTS ARE NOT TO EXCEED IS 2.05 ACRES.
3. A QUALIFIED BIOLOGIST WILL IDENTIFY ALL DISTURBED WETLANDS TO BE RESTORED.
4. IN EXCAVATED AREAS, PRE-CONSTRUCTION GRADES WILL BE RESTORED BY FIRST PLACING SUB-SOILS IN THE EXCAVATION AREA. SECOND, A MINIMUM OF 12 INCHES OF TOP SOIL WILL BE PLACED TO ESTABLISH PRE-CONSTRUCTION GRADES.
5. IMPORTED TOPSOIL, IF USED, SHALL CONTAIN A MINIMUM OF 8% AND MAXIMUM OF 15% ORGANIC MATERIAL AND BE FREE OF WEED SEED.
6. AFTER CONSTRUCTION IS COMPLETE, AND PRIOR TO RESTORATION ACTIVITIES, ALL CONSTRUCTION DEBRIS AND TRASH WILL BE REMOVED FROM WETLAND AREAS AND PRE CONSTRUCTION GRADES WILL BE ACHIEVED.
7. ANY WETLAND SOIL THAT HAS BEEN COMPACTED DURING WORK ACTIVITIES SHALL BE REPLACED TO A DEPTH OF 12 INCHES AND HYDROSEED WITH A DESIGNATED WETLAND SEED MIX.
8. THE AREAS REQUIRING RESTORATION WILL BE REPLANTED WITH NATIVE TREE AND SHRUB SPECIES.

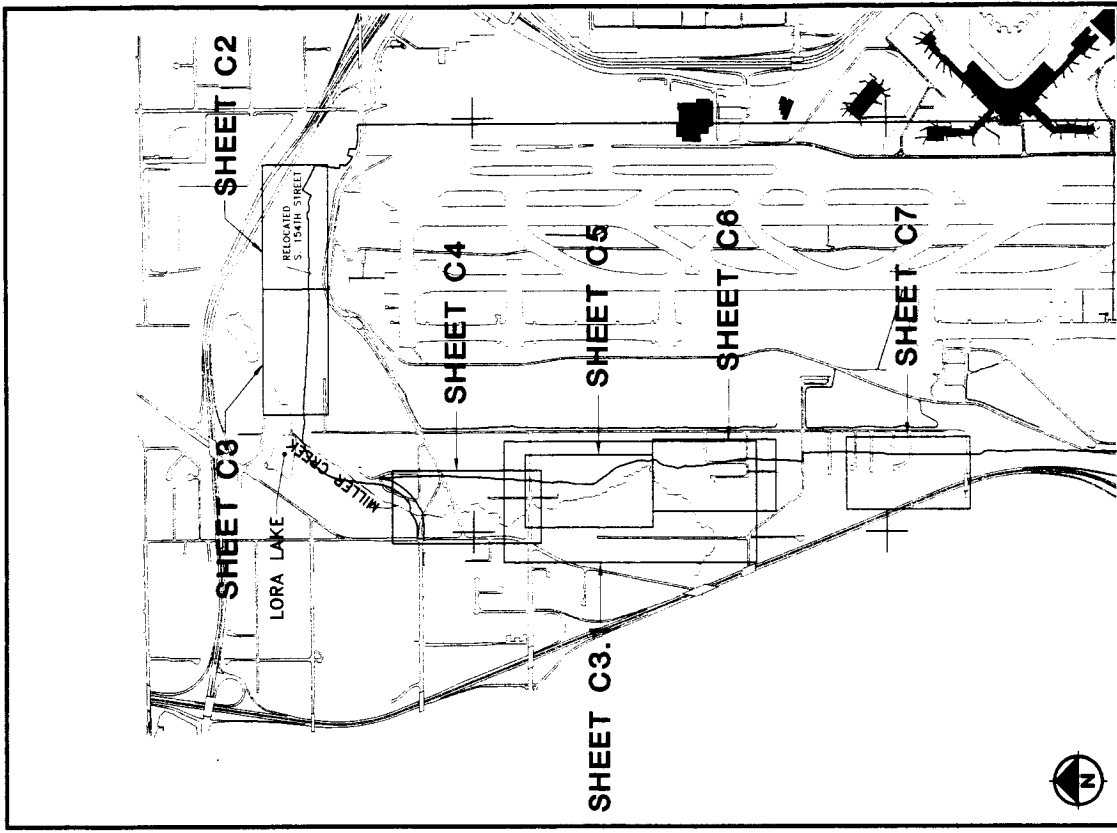
**GENERAL ABBREVIATIONS**

- DIA
  - EQ
  - EXIST
  - EX
  - HT
  - LS
  - MIN
  - MTS
  - PT
  - OC
- AND DIAMETER
  - EQUIVALENT
  - EXISTING
  - EX
  - GAL
  - HEIGHT
  - LIVE STAKE
  - MINIMUM
  - OD SCALE
  - SOILS
  - SOILS
  - ON CENTER

**GENERAL**



**KEY MAP**



**AGENCY REVIEW**  
**NOT FOR CONSTRUCTION**

Port of Seattle  
SEA-TAC INTERNATIONAL AIRPORT  
REPLACEMENT DRAINAGE CHANNELS AND  
RESTORATION OF TEMPORARILY IMPACTED WETLANDS  
VICINITY MAP, SYMBOLS, NOTES  
AND ABBREVIATIONS

PROJECT NO. 291203C1  
SHEET NO. 291203C1  
DATE 11/18/09

SCALE

| NO. | DATE | DESCRIPTION | BY | CHKD |
|-----|------|-------------|----|------|
|     |      |             |    |      |
|     |      |             |    |      |
|     |      |             |    |      |
|     |      |             |    |      |

| NO. | DATE | DESCRIPTION | BY | CHKD |
|-----|------|-------------|----|------|
|     |      |             |    |      |
|     |      |             |    |      |
|     |      |             |    |      |
|     |      |             |    |      |

| NO. | DATE | DESCRIPTION | BY | CHKD |
|-----|------|-------------|----|------|
|     |      |             |    |      |
|     |      |             |    |      |
|     |      |             |    |      |
|     |      |             |    |      |

| NO. | DATE | DESCRIPTION | BY | CHKD |
|-----|------|-------------|----|------|
|     |      |             |    |      |
|     |      |             |    |      |
|     |      |             |    |      |
|     |      |             |    |      |

| NO. | DATE | DESCRIPTION | BY | CHKD |
|-----|------|-------------|----|------|
|     |      |             |    |      |
|     |      |             |    |      |
|     |      |             |    |      |
|     |      |             |    |      |

| NO. | DATE | DESCRIPTION | BY | CHKD |
|-----|------|-------------|----|------|
|     |      |             |    |      |
|     |      |             |    |      |
|     |      |             |    |      |
|     |      |             |    |      |

| NO. | DATE | DESCRIPTION | BY | CHKD |
|-----|------|-------------|----|------|
|     |      |             |    |      |
|     |      |             |    |      |
|     |      |             |    |      |
|     |      |             |    |      |

| NO. | DATE | DESCRIPTION | BY | CHKD |
|-----|------|-------------|----|------|
|     |      |             |    |      |
|     |      |             |    |      |
|     |      |             |    |      |
|     |      |             |    |      |

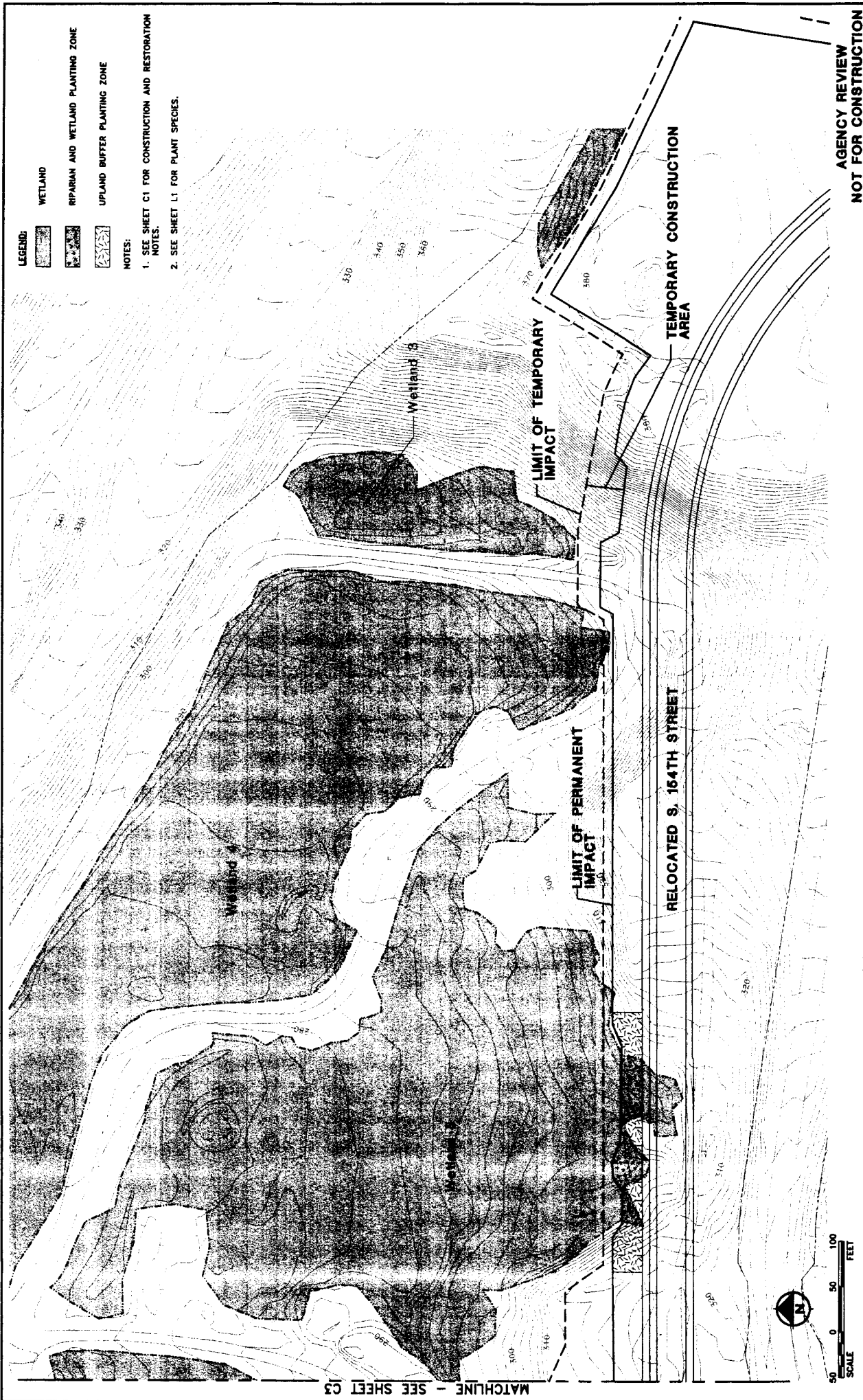
| NO. | DATE | DESCRIPTION | BY | CHKD |
|-----|------|-------------|----|------|
|     |      |             |    |      |
|     |      |             |    |      |
|     |      |             |    |      |
|     |      |             |    |      |

| NO. | DATE | DESCRIPTION | BY | CHKD |
|-----|------|-------------|----|------|
|     |      |             |    |      |
|     |      |             |    |      |
|     |      |             |    |      |
|     |      |             |    |      |

| NO. | DATE | DESCRIPTION | BY | CHKD |
|-----|------|-------------|----|------|
|     |      |             |    |      |
|     |      |             |    |      |
|     |      |             |    |      |
|     |      |             |    |      |

| NO. | DATE | DESCRIPTION | BY | CHKD |
|-----|------|-------------|----|------|
|     |      |             |    |      |
|     |      |             |    |      |
|     |      |             |    |      |
|     |      |             |    |      |

| NO. | DATE | DESCRIPTION | BY | CHKD |
|-----|------|-------------|----|------|
|     |      |             |    |      |
|     |      |             |    |      |
|     |      |             |    |      |
|     |      |             |    |      |



- LEGEND:**
- WETLAND
  - RIPARIAN AND WETLAND PLANTING ZONE
  - UPLAND BUFFER PLANTING ZONE

- NOTES:**
1. SEE SHEET C1 FOR CONSTRUCTION AND RESTORATION NOTES.
  2. SEE SHEET L1 FOR PLANT SPECIES.

MATCHLINE - SEE SHEET C3

DATE: 11/07/05  
 DRAWN: J. B. BROWN  
 CHECKED: J. B. BROWN  
 PROJECT: 2812018A2  
 SHEET: 2812018A2-2  
 STA: 0000+00 TO 0000+00

CALL 48 HOURS BEFORE YOU DIG 1-800-424-5555

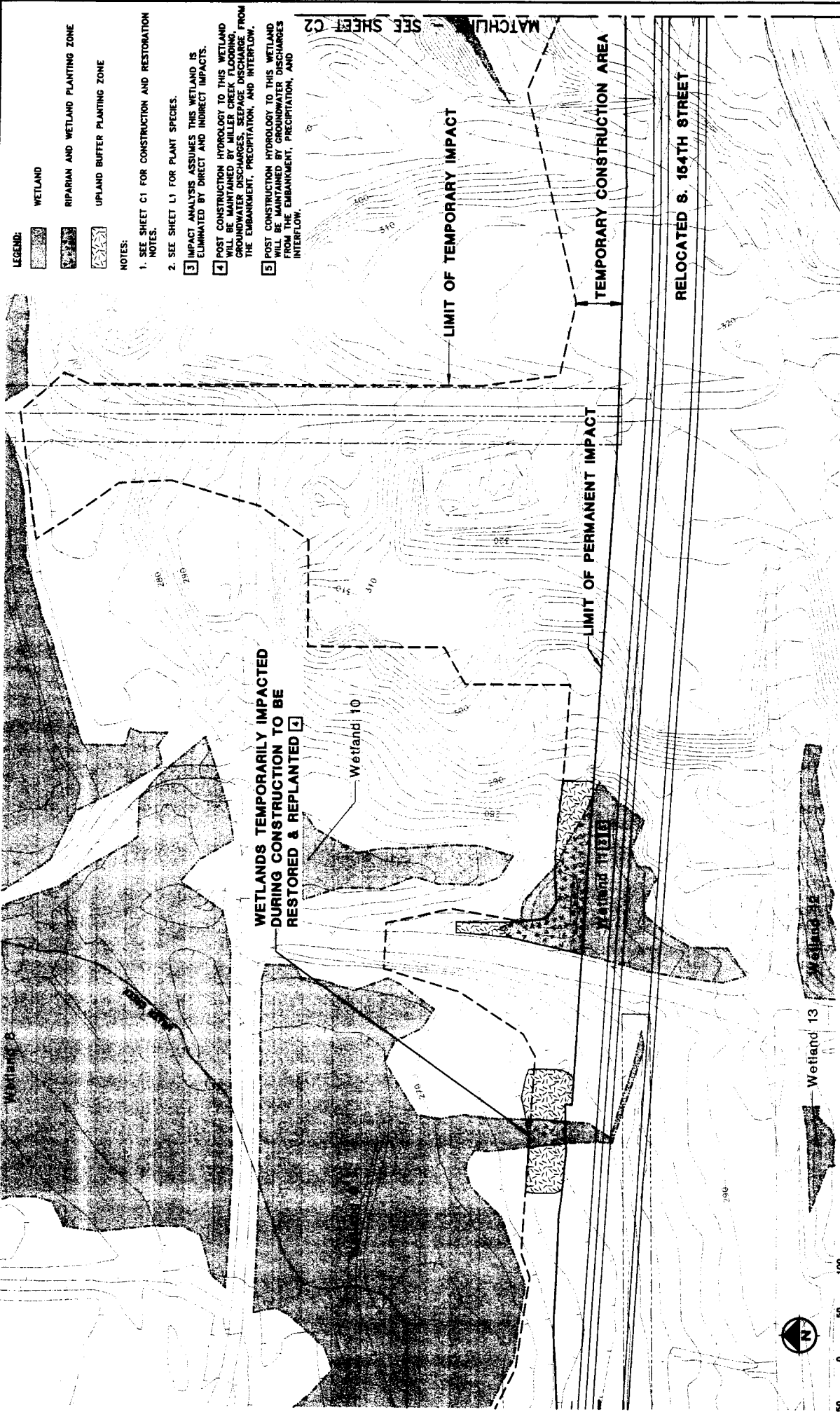
**Paramatrix, Inc.**  
 5808 Lt. Washington Blvd. NE  
 Kirkland, WA 98033  
 Ph: (425) 822-8880  
 Quality Service Through Employee Ownership  
 P. TERRY

PROJECT: SEA-TAC INTERNATIONAL AIRPORT  
 SUBJECT: REPLACEMENT DRAINAGE CHANNELS AND RESTORATION OF TEMPORARILY IMPACTED WETLANDS  
 SHEET NO.: PLAN

AGENCY REVIEW  
 NOT FOR CONSTRUCTION

2812018A2  
APPENDIX D

AR 049486



- LEGEND:**
- WETLAND
  - RIPARIAN AND WETLAND PLANTING ZONE
  - UPLAND BUFFER PLANTING ZONE

- NOTES:**
1. SEE SHEET C1 FOR CONSTRUCTION AND RESTORATION NOTES.
  2. SEE SHEET L1 FOR PLANT SPECIES.
  3. IMPACT ANALYSIS ASSUMES THIS WETLAND IS ELIMINATED BY DIRECT AND INDIRECT IMPACTS.
  4. POST CONSTRUCTION HYDROLOGY TO THIS WETLAND WILL BE MAINTAINED BY MILLER CREEK FLOODING, GROUNDWATER DISCHARGES, SEEPAGE DISCHARGE FROM THE EMBANKMENT, PRECIPITATION, AND INTERFLOW.
  5. POST CONSTRUCTION HYDROLOGY TO THIS WETLAND WILL BE MAINTAINED BY GROUNDWATER DISCHARGES FROM THE EMBANKMENT, PRECIPITATION, AND INTERFLOW.

**WETLANDS TEMPORARILY IMPACTED DURING CONSTRUCTION TO BE RESTORED & REPLANTED [3]**

**AGENCY REVIEW NOT FOR CONSTRUCTION**

Port of Seattle  
SEA-TAC INTERNATIONAL AIRPORT  
REPLACEMENT DRAINAGE CHANNELS AND  
RESTORATION OF TEMPORARILY IMPACTED WETLANDS  
SHEET NO. 02  
PLAN

| NO. | DATE | BY | REVISIONS |
|-----|------|----|-----------|
|     |      |    |           |
|     |      |    |           |

| NO. | DATE | BY | REVISIONS |
|-----|------|----|-----------|
|     |      |    |           |
|     |      |    |           |
|     |      |    |           |

**PROJECT:**  
SEA-TAC INTERNATIONAL AIRPORT  
REPLACEMENT DRAINAGE CHANNELS AND  
RESTORATION OF TEMPORARILY IMPACTED WETLANDS  
SHEET NO. 02  
PLAN

**Parametrix, Inc.**  
5808 Lt. Washington Blvd. NE  
Kirkland, WA 98033  
Ph: (425) 822-8880  
Quality Service Through Employee Ownership  
P. 17477

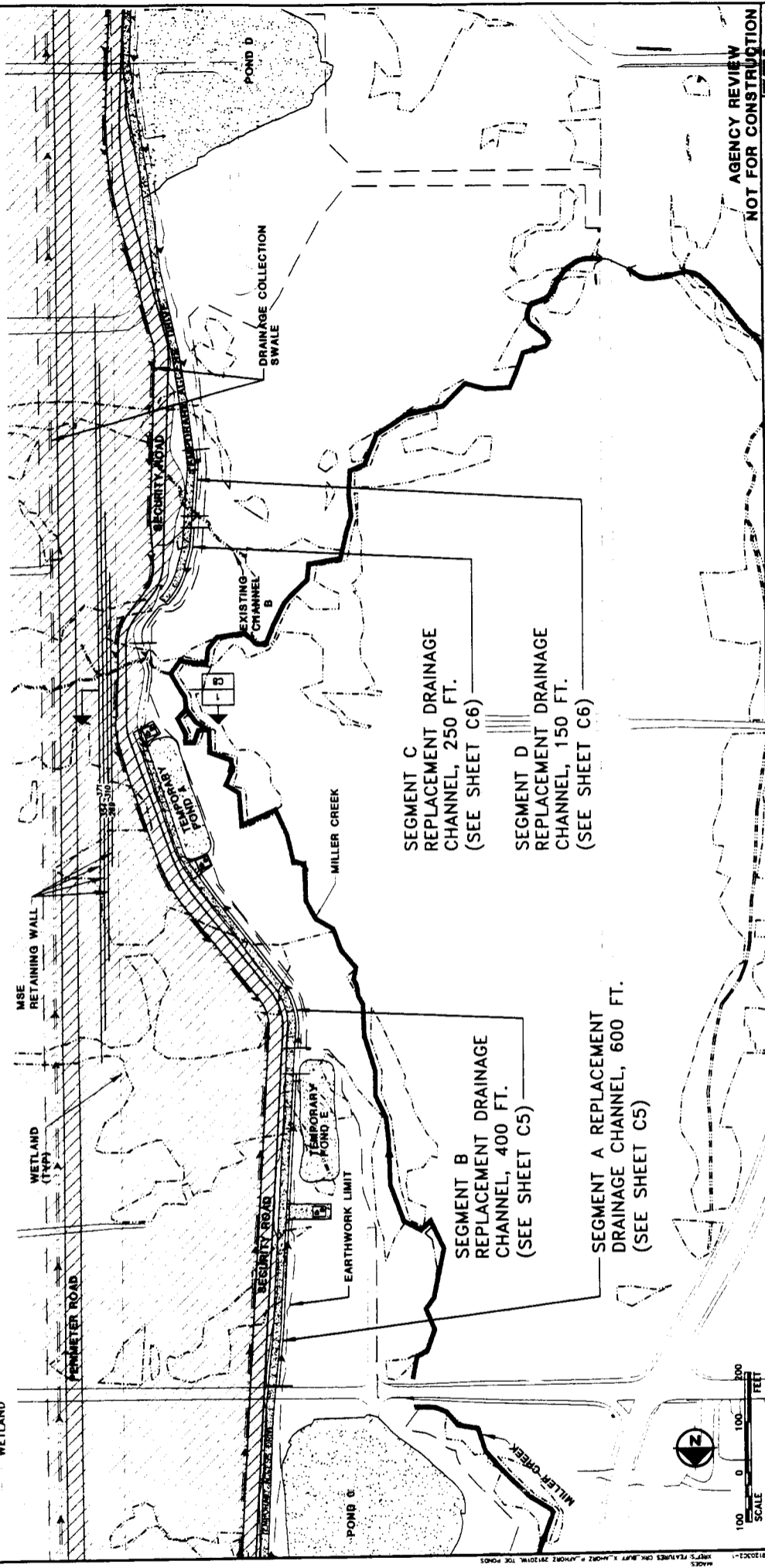
CALL 48 HOURS BEFORE YOU DIG  
1-800-421-5555



AR 049487

**LEGEND**

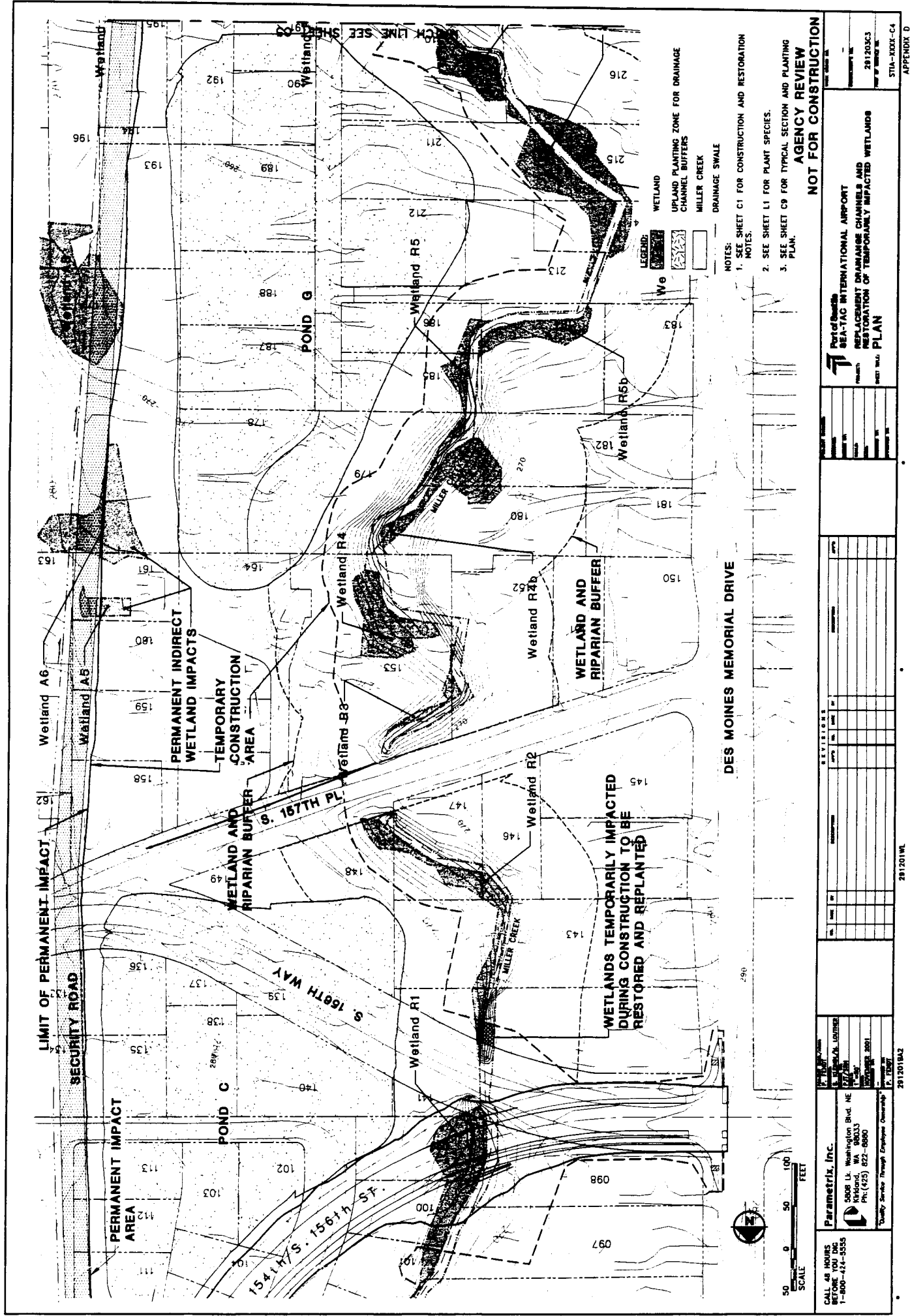
- STORMWATER POND
- PUMPING FACILITY
- FILL EMBANKMENT
- TEMPORARY IMPACT LINE
- WETLAND
- REPLACEMENT DRAINAGE CHANNEL AND FLOW DIRECTION
- TEMPORARY DRAINAGE CHANNEL
- DRAINAGE COLLECTION SWALE



AGENCY REVIEW  
NOT FOR CONSTRUCTION

|                                                                                                                                                                                |  |                                                                                             |
|--------------------------------------------------------------------------------------------------------------------------------------------------------------------------------|--|---------------------------------------------------------------------------------------------|
| <p><b>Parametrix, Inc.</b><br/>5808 1st. Washington Blvd. NE<br/>Kirkland, WA 98033<br/>Ph: (425) 822-8888</p> <p>CALL 48 HOURS BEFORE YOU DIG<br/>1-800-421-5555</p>          |  | <p>DATE: 11/13/03<br/>PROJECT: 291203C2-1<br/>DRAWING NO.: STA-2003-C3.1<br/>APPENDIX D</p> |
| <p>PROJECT: SEA-TAC INTERNATIONAL AIRPORT<br/>REPLACEMENT OF DRAINAGE CHANNELS AND LOCATION OF TEMPORARILY IMPACTED WETLANDS<br/>LOCATION OF REPLACEMENT DRAINAGE CHANNELS</p> |  | <p>SCALE: 1" = 100'</p>                                                                     |
| <p>WETLAND (TYP)</p>                                                                                                                                                           |  | <p>KEYMAP.DWG</p>                                                                           |

AR 049488



MARKS: 1/17/07 P:\01015 BA2 281201A2 POINTS 281201A1 TOC MODS 154001 SWALK-WC-COV-A-ATTACH  
 DATE: 1/17/07 P:\01015 BA2 281201A2 POINTS 281201A1 TOC MODS 154001 SWALK-WC-COV-A-ATTACH  
 PLOT: 1/17/07 P:\01015 BA2 281201A2 POINTS 281201A1 TOC MODS 154001 SWALK-WC-COV-A-ATTACH

CALL 48 HOURS BEFORE YOU DIG  
 1-800-424-5555

**Parameterix, Inc.**  
 5008 Lk. Washington Blvd. NE  
 Kirkland, WA 98033  
 Ph: (425) 822-8800

Quality Service Through Employee Ownership  
 P. 17087

281201A2

| REVISIONS |      |             |
|-----------|------|-------------|
| NO.       | DATE | DESCRIPTION |
|           |      |             |
|           |      |             |
|           |      |             |
|           |      |             |
|           |      |             |
|           |      |             |
|           |      |             |
|           |      |             |
|           |      |             |
|           |      |             |

Part of Seattle  
 SEA-TAC INTERNATIONAL AIRPORT  
 REPLACEMENT DRAINAGE CHANNELS AND  
 RESTORATION OF TEMPORARILY IMPACTED WETLANDS  
 PLAN

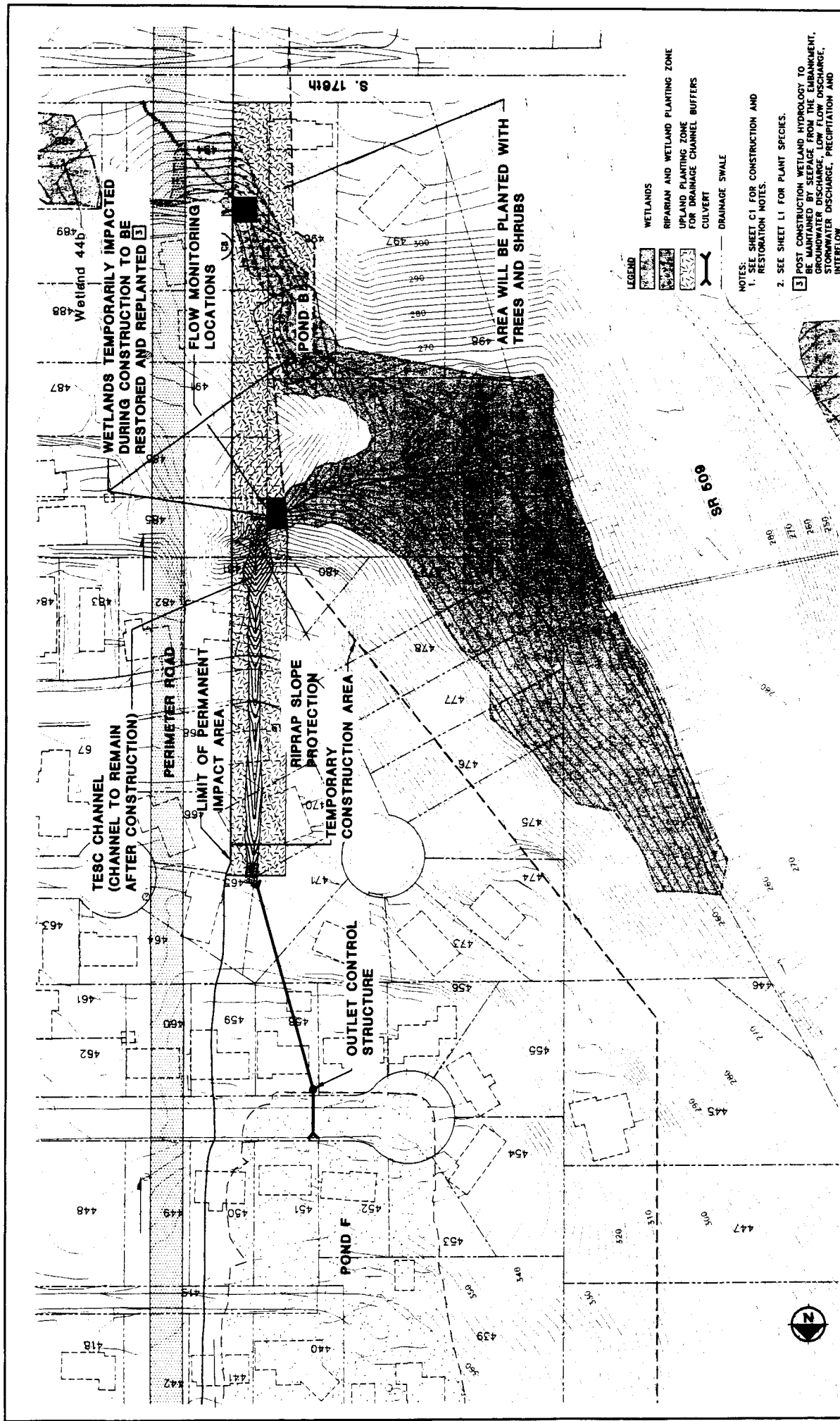
281201A2

281201A2  
 STA-100X-C4  
 APPENDIX D

AR 049489







- LEGEND**
- WETLANDS
  - RIPARIAN AND WETLAND PLANTING ZONE
  - UPLAND PLANTING ZONE FOR DRAINAGE CHANNEL BUFFERS
  - CULVERT
  - DRAINAGE SWALE

**NOTES:**  
 1. SEE SHEET C1 FOR CONSTRUCTION AND RESTORATION NOTES.  
 2. SEE SHEET L1 FOR PLANT SPECIES.  
 3. POST CONSTRUCTION WETLAND HYDROLOGY TO BE MAINTAINED BY SEEPAGE FROM THE EMBANKMENT, GROUNDWATER DISCHARGE, LOW FLOW DISCHARGE, STORMWATER DISCHARGE, PRECIPITATION AND INTERFLOW.

**AGENCY REVIEW**  
**NOT FOR CONSTRUCTION**

Port of Seattle  
 SEATTLE INTERNATIONAL AIRPORT  
 REPLACEMENT DRAINAGE CHANNELS AND  
 RESTORATION OF TEMPORARILY IMPACTED WETLANDS  
 SHEET 2001  
 STA. 0000-07  
 APPENDIX D

| NO. | DATE | BY | DESCRIPTION |
|-----|------|----|-------------|
|     |      |    |             |
|     |      |    |             |

| NO. | DATE | BY | DESCRIPTION |
|-----|------|----|-------------|
|     |      |    |             |
|     |      |    |             |

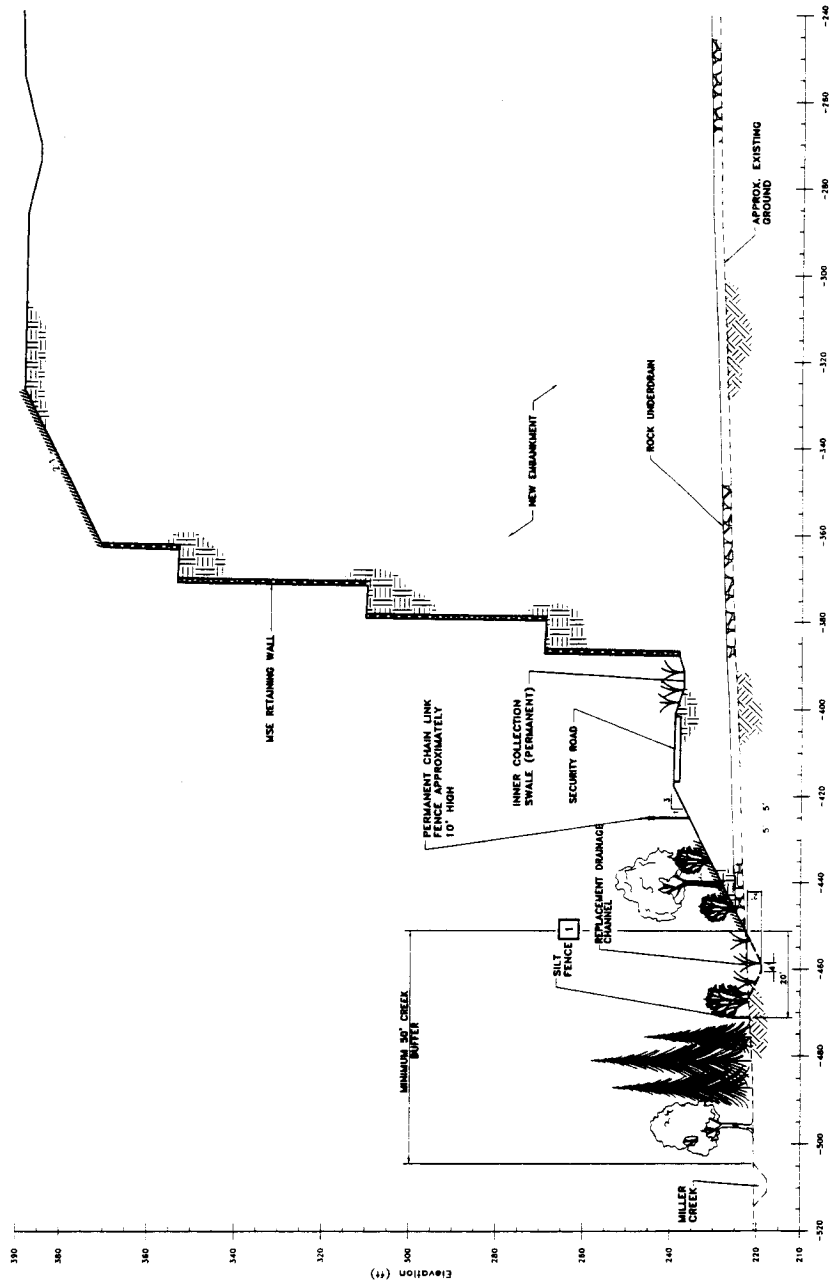
DATE: 11/14/01  
 PLANNED: 2912008  
 SHEET: 2912018A2

**Parametrix, Inc.**  
 5608 Lk. Washington Blvd. NE  
 Kirkland, WA 98033  
 Ph: (425) 822-8800

CALL 48 HOURS BEFORE YOU DIG 1-800-421-5555  
 Quality Service Through Employee Ownership

AR 049492





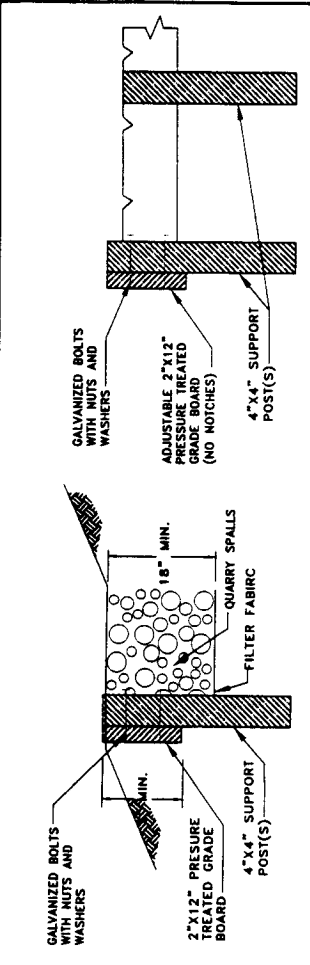
NOTES:  
 1 TO BE REMOVED FOLLOWING RESTORATION

SECTION 1  
 STREAM BUFFER AND EMBANKMENT C3.1, C4, C5, C6  
 HORIZ. SCALE: 1"=15'  
 VERT. SCALE: 1"=15'

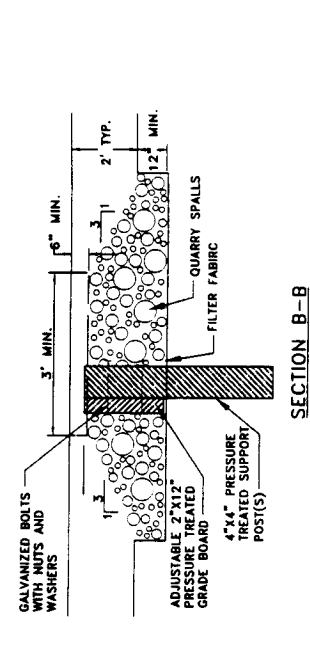
AGENCY REVIEW  
 NOT FOR CONSTRUCTION

| CALL 48 HOURS BEFORE YOU DIG<br>1-800-472-5555 | <b>Parameterix, Inc.</b><br>5808 Lk. Washington Blvd. NE<br>Kirkland, WA 98033<br>Ph: (425) 872-8000<br>Quality Service Through Employee Ownership<br>P. TRAMPT | PROJECT NO.<br>DRAWING NO.<br>DATE: 10/20/01<br>PLANK: 291203C7 | PORT OF SEATTLE<br>BEA-TAG INTERNATIONAL AIRPORT<br>REPLACEMENT DRAINAGE CHANNELS AND RESTORATION OF TEMPORARILY IMPACTED WETLANDS<br>STREAM BUFFER AND EMBANKMENT<br>CROSS SECTION | PROJECT NO.<br>DRAWING NO.<br>DATE: 10/20/01<br>PLANK: 291203C7 | STA-BOOK-C8<br>APPENDIX D |                                                                                                                                                                                                          |     |      |
|------------------------------------------------|-----------------------------------------------------------------------------------------------------------------------------------------------------------------|-----------------------------------------------------------------|-------------------------------------------------------------------------------------------------------------------------------------------------------------------------------------|-----------------------------------------------------------------|---------------------------|----------------------------------------------------------------------------------------------------------------------------------------------------------------------------------------------------------|-----|------|
|                                                |                                                                                                                                                                 |                                                                 |                                                                                                                                                                                     |                                                                 |                           | REVISIONS<br><table border="1"> <thead> <tr> <th>NO.</th> <th>DATE</th> <th>BY</th> <th>DESCRIPTION</th> </tr> </thead> <tbody> <tr> <td> </td> <td> </td> <td> </td> <td> </td> </tr> </tbody> </table> | NO. | DATE |
| NO.                                            | DATE                                                                                                                                                            | BY                                                              | DESCRIPTION                                                                                                                                                                         |                                                                 |                           |                                                                                                                                                                                                          |     |      |
|                                                |                                                                                                                                                                 |                                                                 |                                                                                                                                                                                     |                                                                 |                           |                                                                                                                                                                                                          |     |      |

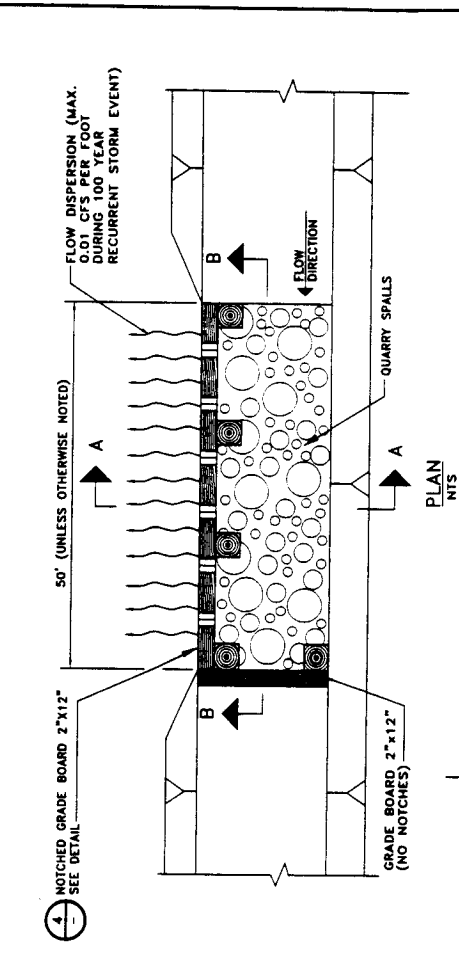
AR 049493



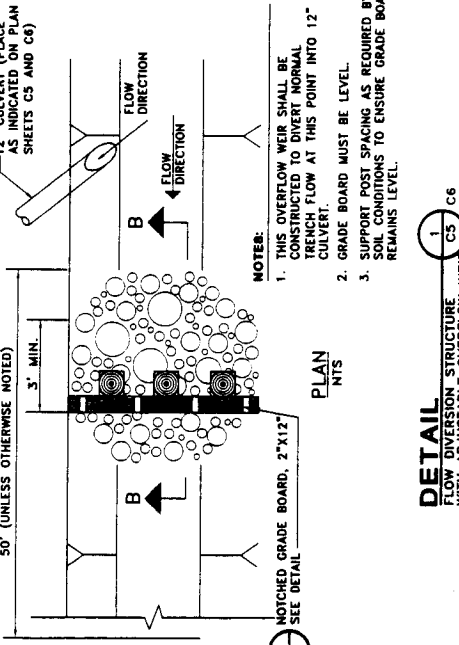
SECTION A-A  
NTS



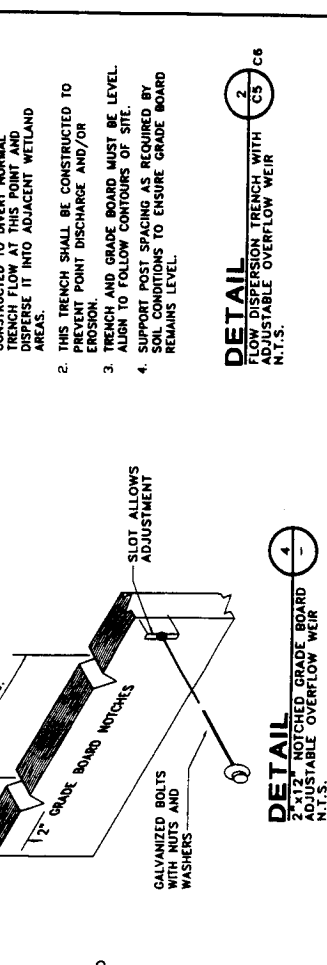
SECTION B-B  
NTS



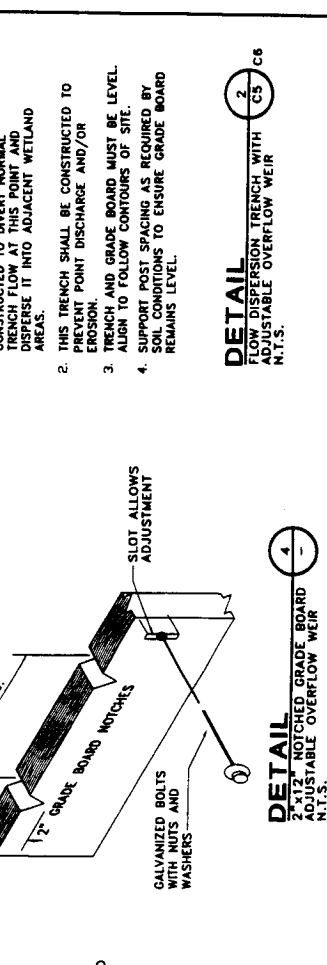
PLAN  
NTS



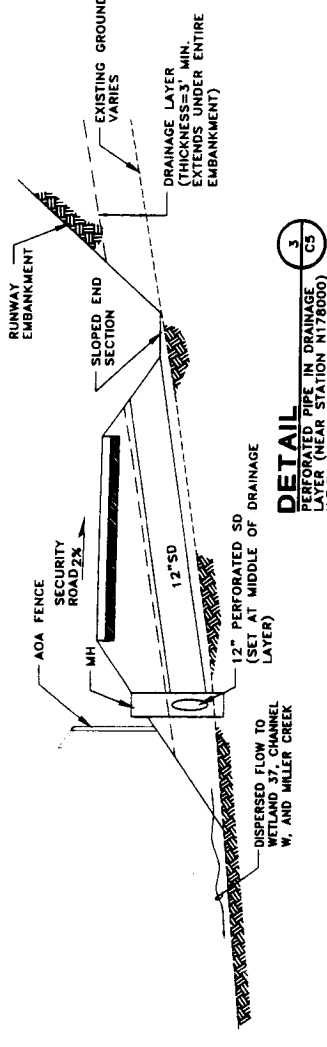
PLAN  
NTS



DETAIL  
2"x12" NOTCHED GRADE BOARD  
ADJUSTABLE OVERFLOW WEIR  
N.T.S.



DETAIL  
2"x12" NOTCHED GRADE BOARD  
ADJUSTABLE OVERFLOW WEIR  
N.T.S.



DETAIL  
FLOW DIVERSION STRUCTURE  
FLOW DIVERSION OVERFLOW WEIR  
N.T.S.

- NOTES:
1. THIS OVERFLOW WEIR SHALL BE CONSTRUCTED TO DIVERT NORMAL TRENCH FLOW AT THIS POINT AND DISPERSE IT INTO ADJACENT WETLAND AREAS.
  2. THIS TRENCH SHALL BE CONSTRUCTED TO PREVENT POINT DISCHARGE AND/OR EROSION.
  3. TRENCH AND GRADE BOARD MUST BE LEVEL ALIGN TO FOLLOW CONTOURS OF SITE.
  4. SUPPORT POST SPACING AS REQUIRED BY SOIL CONDITIONS TO ENSURE GRADE BOARD REMAINS LEVEL.

**DETAIL**  
FLOW DISPERSION TRENCH WITH  
ADJUSTABLE OVERFLOW WEIR  
N.T.S.

**AGENCY REVIEW**  
**NOT FOR CONSTRUCTION**

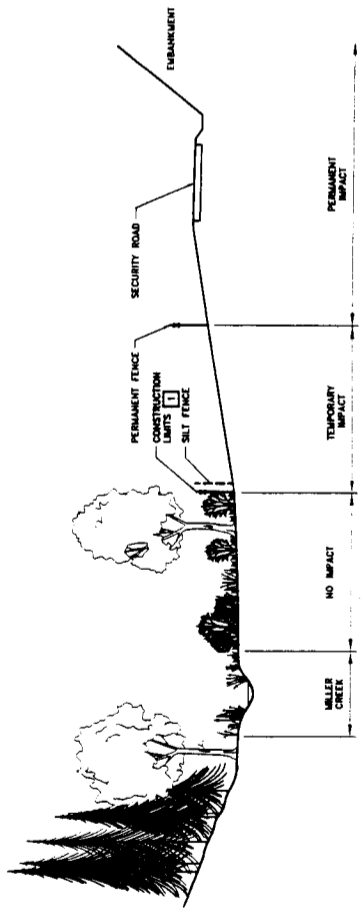
- NOTES:
1. THIS OVERFLOW WEIR SHALL BE CONSTRUCTED TO DIVERT NORMAL TRENCH FLOW AT THIS POINT INTO 12" CULVERT.
  2. GRADE BOARD MUST BE LEVEL.
  3. SUPPORT POST SPACING AS REQUIRED BY SOIL CONDITIONS TO ENSURE GRADE BOARD REMAINS LEVEL.

**DETAIL**  
FLOW DIVERSION STRUCTURE  
FLOW DIVERSION OVERFLOW WEIR  
N.T.S.

**DETAIL**  
PERFORATED PIPE IN DRAINAGE  
LAYER (NEAR STATION N176000)  
N.T.S.

| CALL 48 HOURS BEFORE YOU DIG<br>1-800-424-3535 |      | Parametrix, Inc.<br>5808 Lk. Washington Blvd. NE<br>Redmond, WA 98033<br>PH: (425) 822-6880 | REVISIONS<br><table border="1"> <thead> <tr> <th>NO.</th> <th>DATE</th> <th>DESCRIPTION</th> </tr> </thead> <tbody> <tr> <td> </td> <td> </td> <td> </td> </tr> <tr> <td> </td> <td> </td> <td> </td> </tr> <tr> <td> </td> <td> </td> <td> </td> </tr> <tr> <td> </td> <td> </td> <td> </td> </tr> </tbody> </table> | NO. | DATE | DESCRIPTION |  |  |  |  |  |  |  |  |  |  |  |  | Part of Seattle<br>SEA-TAC INTERNATIONAL AIRPORT<br>REPLACEMENT DRAINAGE CHANNELS AND<br>RESTORATION OF TEMPORARILY IMPACTED WETLANDS<br><b>FLOW DIVERSION AND DISPERSION<br/>         STRUCTURE DETAILS</b> | PROJECT NO.<br>SHEET NO. | 201203CB-1<br>DATE OF SHEET<br>STA-XXXX-CB.1<br>APPENDIX D |
|------------------------------------------------|------|---------------------------------------------------------------------------------------------|-----------------------------------------------------------------------------------------------------------------------------------------------------------------------------------------------------------------------------------------------------------------------------------------------------------------------|-----|------|-------------|--|--|--|--|--|--|--|--|--|--|--|--|--------------------------------------------------------------------------------------------------------------------------------------------------------------------------------------------------------------|--------------------------|------------------------------------------------------------|
| NO.                                            | DATE | DESCRIPTION                                                                                 |                                                                                                                                                                                                                                                                                                                       |     |      |             |  |  |  |  |  |  |  |  |  |  |  |  |                                                                                                                                                                                                              |                          |                                                            |
|                                                |      |                                                                                             |                                                                                                                                                                                                                                                                                                                       |     |      |             |  |  |  |  |  |  |  |  |  |  |  |  |                                                                                                                                                                                                              |                          |                                                            |
|                                                |      |                                                                                             |                                                                                                                                                                                                                                                                                                                       |     |      |             |  |  |  |  |  |  |  |  |  |  |  |  |                                                                                                                                                                                                              |                          |                                                            |
|                                                |      |                                                                                             |                                                                                                                                                                                                                                                                                                                       |     |      |             |  |  |  |  |  |  |  |  |  |  |  |  |                                                                                                                                                                                                              |                          |                                                            |
|                                                |      |                                                                                             |                                                                                                                                                                                                                                                                                                                       |     |      |             |  |  |  |  |  |  |  |  |  |  |  |  |                                                                                                                                                                                                              |                          |                                                            |

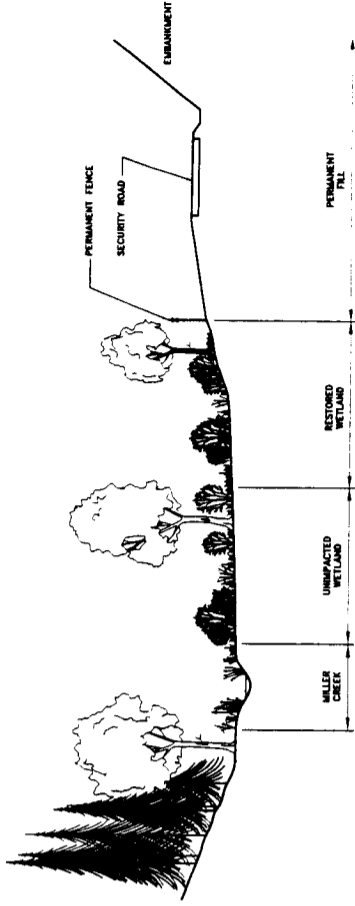
TEMPORARILY IMPACTED WETLAND BEFORE RESTORATION



**SECTION**  
TYPICAL SECTION  
TEMPORARY WETLAND IMPACTS  
NTS

|   |     |
|---|-----|
| 1 | TYP |
|---|-----|

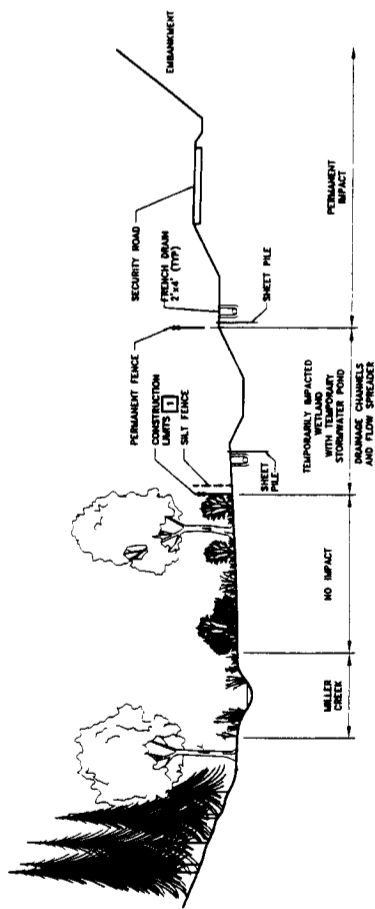
TEMPORARILY IMPACTED WETLAND AFTER RESTORATION



**SECTION**  
TYPICAL SECTION  
RESTORATION OF IMPACTED AREA  
NTS

|   |     |
|---|-----|
| 2 | TYP |
|---|-----|

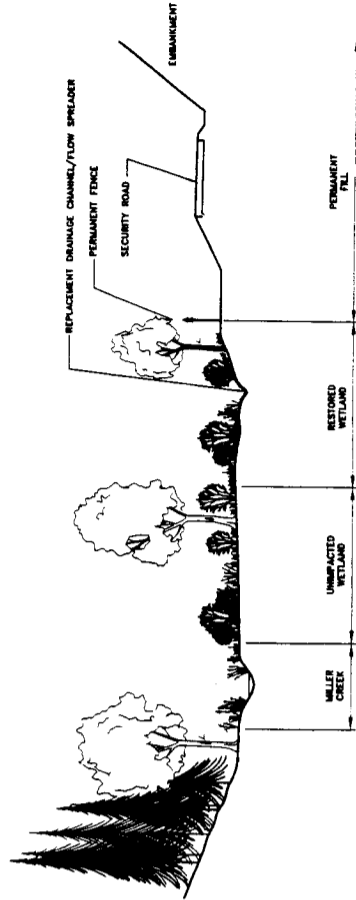
TEMPORARILY IMPACTED WETLAND (AT TEMPORARY POND A) BEFORE RESTORATION



**SECTION**  
TYPICAL SECTION  
TEMP. STORMWATER POND IMPACT  
NTS

|   |     |
|---|-----|
| 3 | TYP |
|---|-----|

TEMPORARILY IMPACTED WETLAND (AT TEMPORARY POND A) AFTER RESTORATION



**SECTION**  
TYPICAL SECTION  
RESTORATION OF IMPACTED AREA  
NTS

|   |     |
|---|-----|
| 4 | TYP |
|---|-----|

NOTE:  
[ ] CONSTRUCTION LIMITS WILL BE MARKED WITH CONSTRUCTION FENCING AND CONCRETE BARRIERS

AGENCY REVIEW  
NOT FOR CONSTRUCTION

|             |          |                  |         |
|-------------|----------|------------------|---------|
| DATE        | 10/20/01 | PLN/NAME         | 291203A |
| SCALE       |          |                  |         |
| DESIGNED BY |          |                  |         |
| CHECKED BY  |          |                  |         |
| DRAWN BY    |          |                  |         |
| PROJECT NO. | 291203A  | DATE OF REVISION |         |
| BY          |          | BY               |         |
| DATE        |          | DATE             |         |

Part of Seattle  
SEA-TAC INTERNATIONAL AIRPORT  
REPLACEMENT DRAINAGE CHANNELS AND  
RESTORATION OF TEMPORARILY IMPACTED WETLANDS  
TYPICAL SECTIONS

|     |      |    |             |
|-----|------|----|-------------|
| NO. | DATE | BY | DESCRIPTION |
|     |      |    |             |

|     |      |    |             |
|-----|------|----|-------------|
| NO. | DATE | BY | DESCRIPTION |
|     |      |    |             |

|     |      |    |             |
|-----|------|----|-------------|
| NO. | DATE | BY | DESCRIPTION |
|     |      |    |             |

|     |      |    |             |
|-----|------|----|-------------|
| NO. | DATE | BY | DESCRIPTION |
|     |      |    |             |

|     |      |    |             |
|-----|------|----|-------------|
| NO. | DATE | BY | DESCRIPTION |
|     |      |    |             |

|     |      |    |             |
|-----|------|----|-------------|
| NO. | DATE | BY | DESCRIPTION |
|     |      |    |             |

|     |      |    |             |
|-----|------|----|-------------|
| NO. | DATE | BY | DESCRIPTION |
|     |      |    |             |

|     |      |    |             |
|-----|------|----|-------------|
| NO. | DATE | BY | DESCRIPTION |
|     |      |    |             |

|     |      |    |             |
|-----|------|----|-------------|
| NO. | DATE | BY | DESCRIPTION |
|     |      |    |             |

|     |      |    |             |
|-----|------|----|-------------|
| NO. | DATE | BY | DESCRIPTION |
|     |      |    |             |

|     |      |    |             |
|-----|------|----|-------------|
| NO. | DATE | BY | DESCRIPTION |
|     |      |    |             |

|     |      |    |             |
|-----|------|----|-------------|
| NO. | DATE | BY | DESCRIPTION |
|     |      |    |             |

|     |      |    |             |
|-----|------|----|-------------|
| NO. | DATE | BY | DESCRIPTION |
|     |      |    |             |

|     |      |    |             |
|-----|------|----|-------------|
| NO. | DATE | BY | DESCRIPTION |
|     |      |    |             |

|     |      |    |             |
|-----|------|----|-------------|
| NO. | DATE | BY | DESCRIPTION |
|     |      |    |             |

|     |      |    |             |
|-----|------|----|-------------|
| NO. | DATE | BY | DESCRIPTION |
|     |      |    |             |

Parametrix, Inc.  
5608 Uk. Washington Blvd. NE  
Kirkland, WA 98033  
Ph: (425) 827-8800  
Quality Service Through Employee Ownership

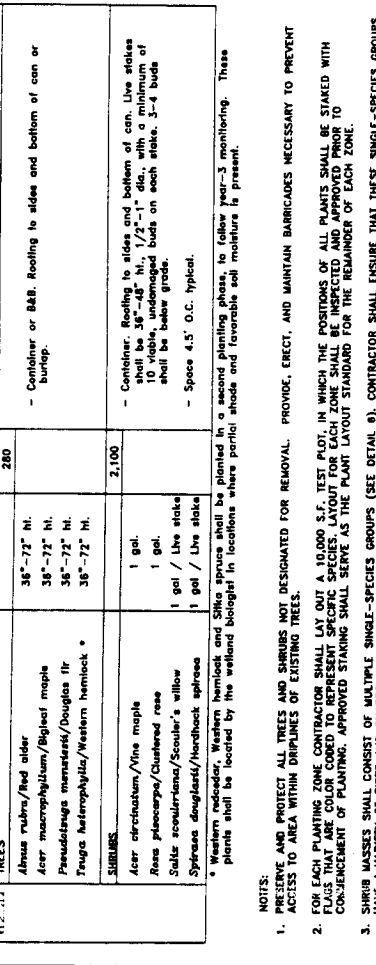
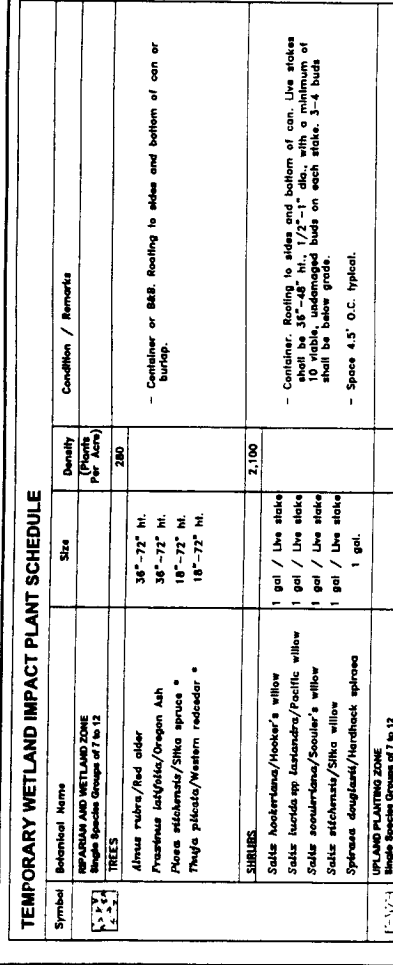
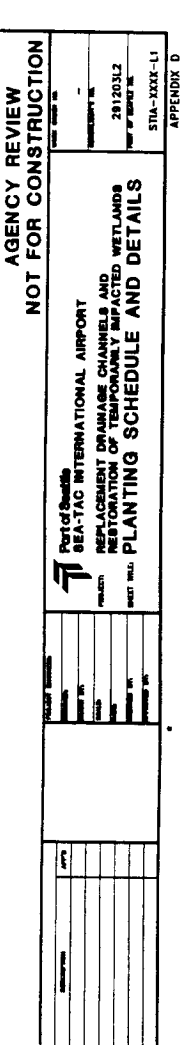
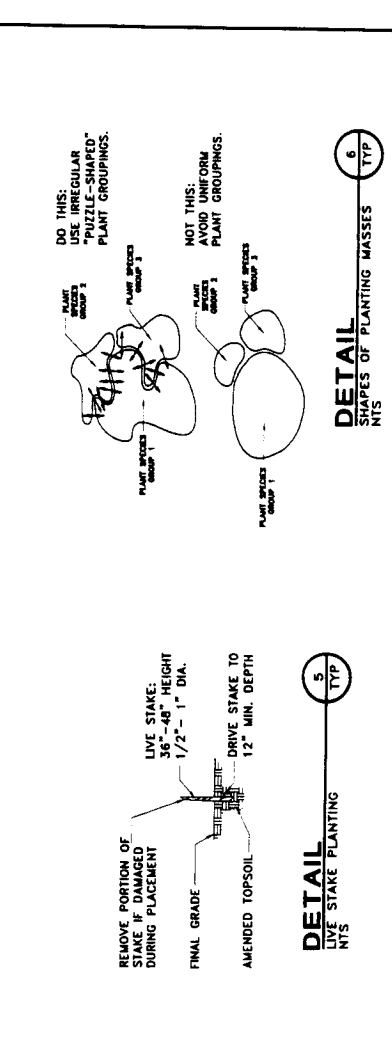
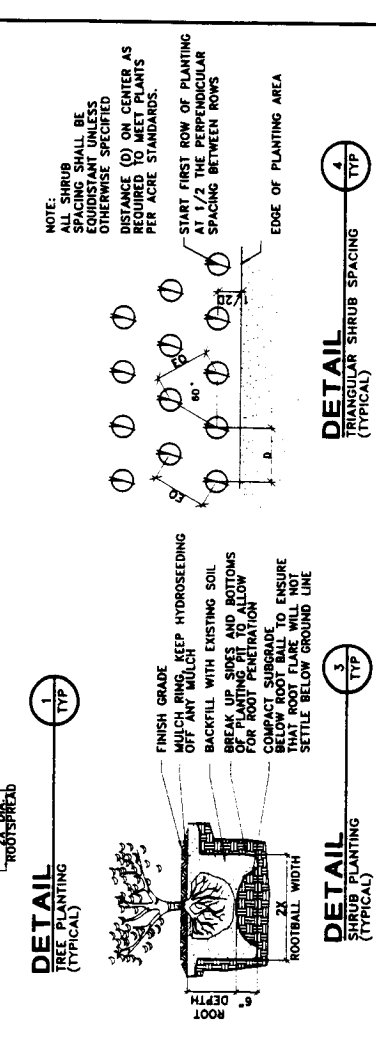
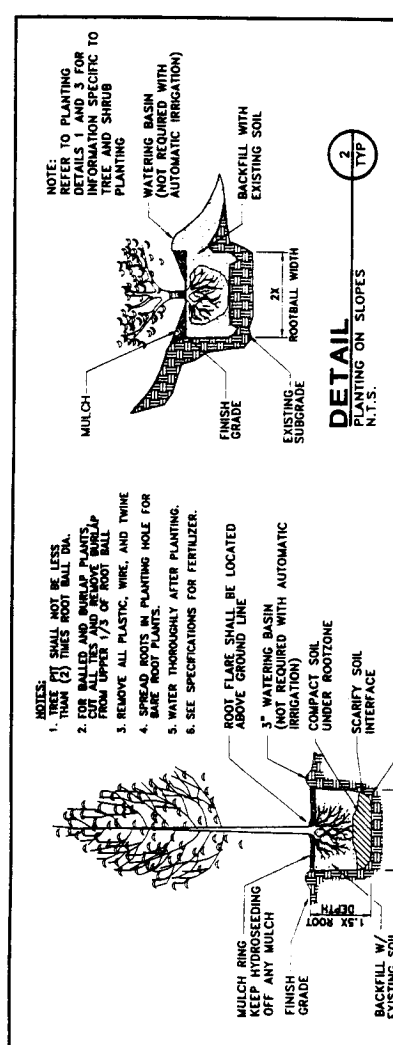
CALL 48 HOURS BEFORE YOU DIG 1-800-424-5555

AR 049495

| TEMPORARY WETLAND IMPACT PLANT SCHEDULE |                                                                    |                    |                           |                                                                                                                                                                                            |
|-----------------------------------------|--------------------------------------------------------------------|--------------------|---------------------------|--------------------------------------------------------------------------------------------------------------------------------------------------------------------------------------------|
| Symbol                                  | Botanical Name                                                     | Size               | Density (Plants Per Acre) | Condition / Remarks                                                                                                                                                                        |
| T-1                                     | REFUGIUM AND WETLAND ZONE<br>Single Species Group of 7 to 12 TREES | 36"-72" Ht.        | 280                       | - Container or BAB. Rooting to sides and bottom of can or burlap.                                                                                                                          |
|                                         |                                                                    | 36"-72" Ht.        |                           | - Container. Rooting to sides and bottom of can. Live stakes shall be 36"-48" Ht., 1/2"-1" dia., with a minimum of 10 viable, undamaged buds on each stake. 3-4 buds shall be below grade. |
|                                         |                                                                    | 18"-72" Ht.        |                           | - Space 4.5' O.C. typical.                                                                                                                                                                 |
| T-2                                     | TREES                                                              | 36"-72" Ht.        | 2,100                     | - Container or BAB. Rooting to sides and bottom of can or burlap.                                                                                                                          |
|                                         |                                                                    | 36"-72" Ht.        |                           | - Container. Rooting to sides and bottom of can. Live stakes shall be 36"-48" Ht., 1/2"-1" dia., with a minimum of 10 viable, undamaged buds on each stake. 3-4 buds shall be below grade. |
|                                         |                                                                    | 18"-72" Ht.        |                           | - Space 4.5' O.C. typical.                                                                                                                                                                 |
| T-3                                     | SHRUBS                                                             | 1 gal / Live stake | 280                       | - Container or BAB. Rooting to sides and bottom of can or burlap.                                                                                                                          |
|                                         |                                                                    | 1 gal / Live stake |                           | - Container. Rooting to sides and bottom of can. Live stakes shall be 36"-48" Ht., 1/2"-1" dia., with a minimum of 10 viable, undamaged buds on each stake. 3-4 buds shall be below grade. |
|                                         |                                                                    | 1 gal / Live stake |                           | - Space 4.5' O.C. typical.                                                                                                                                                                 |
| T-4                                     | UPLAND PLANTING ZONE<br>Single Species Group of 7 to 12 TREES      | 36"-72" Ht.        | 280                       | - Container or BAB. Rooting to sides and bottom of can or burlap.                                                                                                                          |
|                                         |                                                                    | 36"-72" Ht.        |                           | - Container. Rooting to sides and bottom of can. Live stakes shall be 36"-48" Ht., 1/2"-1" dia., with a minimum of 10 viable, undamaged buds on each stake. 3-4 buds shall be below grade. |
|                                         |                                                                    | 18"-72" Ht.        |                           | - Space 4.5' O.C. typical.                                                                                                                                                                 |
| T-5                                     | SHRUBS                                                             | 1 gal.             | 2,100                     | - Container. Rooting to sides and bottom of can. Live stakes shall be 36"-48" Ht., 1/2"-1" dia., with a minimum of 10 viable, undamaged buds on each stake. 3-4 buds shall be below grade. |
|                                         |                                                                    | 1 gal.             |                           | - Container. Rooting to sides and bottom of can. Live stakes shall be 36"-48" Ht., 1/2"-1" dia., with a minimum of 10 viable, undamaged buds on each stake. 3-4 buds shall be below grade. |
|                                         |                                                                    | 1 gal / Live stake |                           | - Space 4.5' O.C. typical.                                                                                                                                                                 |

NOTES:

- ACCESS TO AND PROTECT ALL TREES AND SHRUBS NOT DESIGNATED FOR REMOVAL. PROVIDE, ERECT, AND MAINTAIN BARRICADES NECESSARY TO PREVENT ACCESS TO AREA WITHIN DRILLPILES OF EXISTING TREES.
- FOR EACH PLANTING ZONE CONTRACTOR SHALL LAY OUT A 10,000 S.F. TEST PLOT, IN WHICH THE POSITIONS OF ALL PLANTS SHALL BE STAKED WITH FLAG NUMBERS AND COLOR CODED TO REPRESENT SPECIFIC SPECIES. LAYOUT FOR EACH ZONE SHALL BE INSPECTED AND APPROVED PRIOR TO COMMENCEMENT OF PLANTING. APPROVED STAKING SHALL SERVE AS THE PLANT LAYOUT STANDARD FOR THE REMAINDER OF EACH ZONE.
- SHRUB MASSES SHALL CONSIST OF MULTIPLE SINGLE-SPECIES GROUPS (SEE DETAIL 9). CONTRACTOR SHALL ENSURE THAT THESE SINGLE-SPECIES GROUPS HAVE A VARIETY OF SIZES AND SHAPES, AND THAT SHRUB MASSES HAVE A VARIETY OF SPECIES. SEE PLANTING SCHEDULE FOR NUMBERS OF PLANTS IN SINGLE-SPECIES GROUPS.
- CONTRACTOR SHALL HYDROSEED ALL PLANTING AREAS. RE-SEED ALL AREAS THAT ARE DISTURBED BY SUBSEQUENT WORK. KEEP HYDROSEEDING OFF ANY MULCH CIRCLES EXCEPT WHERE NEEDED TO PROTECT ROOTS OF CONIFERS.
- LIVE STAKE WILLOW SPECIES MAY BE SUBSTITUTED FOR 1 GALLON CONTAINER IF SITE CONDITIONS ARE WARRANTED. LIVE STAKES SHOULD BE 36"-48" IN HT., 1/2"-1" IN DIA., WITH A MINIMUM OF 10 Viable, UN-DAMAGED BUDS ON EACH STAKE. 3-4 BUDS SHALL BE BELOW GRADE.



|           |      |    |          |       |
|-----------|------|----|----------|-------|
| REVISIONS |      |    |          |       |
| NO.       | DATE | BY | REVISION | APP'D |
|           |      |    |          |       |
|           |      |    |          |       |
|           |      |    |          |       |
|           |      |    |          |       |
|           |      |    |          |       |
|           |      |    |          |       |
|           |      |    |          |       |
|           |      |    |          |       |
|           |      |    |          |       |

**Parametrix, Inc.**  
5808 Lt. Washington Blvd. NE  
Kirkland, WA 98033  
Ph: (425) 822-0800

CALL 48 HOURS BEFORE YOU DIG  
1-800-424-5555

QUALITY SERVICE THROUGH EMPLOYEE OWNERSHIP  
P. 02007

AR 049496



Port of Seattle  
Aviation Division

# APPENDIX E

## AUBURN WETLAND MITIGATION FOR SEATTLE-TACOMA INTERNATIONAL AIRPORT

AGENCY REVIEW  
NOT FOR CONSTRUCTION

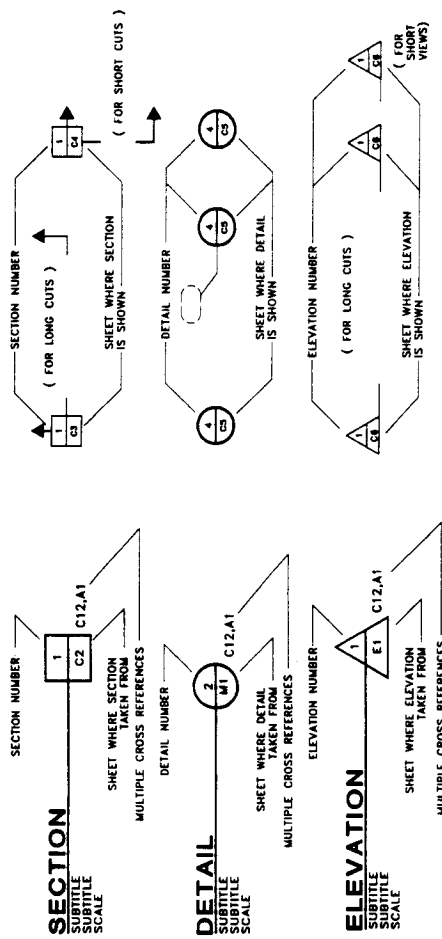
| SHEET NO.     | SHEET TITLE                                    | SHEET NO.    | SHEET TITLE                   | SHEET NO. | SHEET TITLE |
|---------------|------------------------------------------------|--------------|-------------------------------|-----------|-------------|
| STA-9804-11   | TITLE SHEET                                    | STA-9804-17  | PLANTING PLAN NW              |           |             |
| STA-9804-C1   | VICINITY MAP, SYMBOLS, NOTES AND ABBREVIATIONS | STA-9804-L7  | PLANTING PLAN SW              |           |             |
| STA-9804-C2   | PROJECT AREA AND SHEET KEY                     | STA-9804-L8  | PLANTING SCHEDULE             |           |             |
| STA-9804-C3   | PHASE 1 GRADING PLAN NE                        | STA-9804-L9  | PLANTING SCHEDULE AND DETAILS |           |             |
| STA-9804-C4   | PHASE 1 GRADING PLAN SE                        | STA-9804-L10 |                               |           |             |
| STA-9804-C5   | PHASE 2 GRADING PLAN NW                        |              |                               |           |             |
| STA-9804-C6   | PHASE 2 GRADING PLAN SW                        |              |                               |           |             |
| STA-9804-C7   | SECTIONS AND DETAILS                           |              |                               |           |             |
| STA-9804-C7.1 | SECTIONS AND DETAILS                           |              |                               |           |             |
| STA-9804-C8   | GRADING SECTIONS AND DETAILS                   |              |                               |           |             |
| STA-9804-C8.1 | BUFFER AND TEMPORARY MAINTENANCE ROAD PROFILE  |              |                               |           |             |
| STA-9804-C8.2 | SECTIONS AND DETAILS                           |              |                               |           |             |
| STA-9804-C9   | SOIL AND HABITAT FEATURES PLAN                 |              |                               |           |             |
| STA-9804-TEL  | TESC PLAN                                      |              |                               |           |             |
| STA-9804-L1   | IRRIGATION DETAILS AND LEGEND                  |              |                               |           |             |
| STA-9804-L2   | PHASE 1 IRRIGATION PLAN NE                     |              |                               |           |             |
| STA-9804-L3   | PHASE 1 IRRIGATION PLAN SE                     |              |                               |           |             |
| STA-9804-L4   | MISCELLANEOUS CONSTRUCTION DETAILS             |              |                               |           |             |
| STA-9804-L5   | PLANTING PLAN NE                               |              |                               |           |             |
| STA-9804-L6   | PLANTING PLAN SE                               |              |                               |           |             |

AR 049497

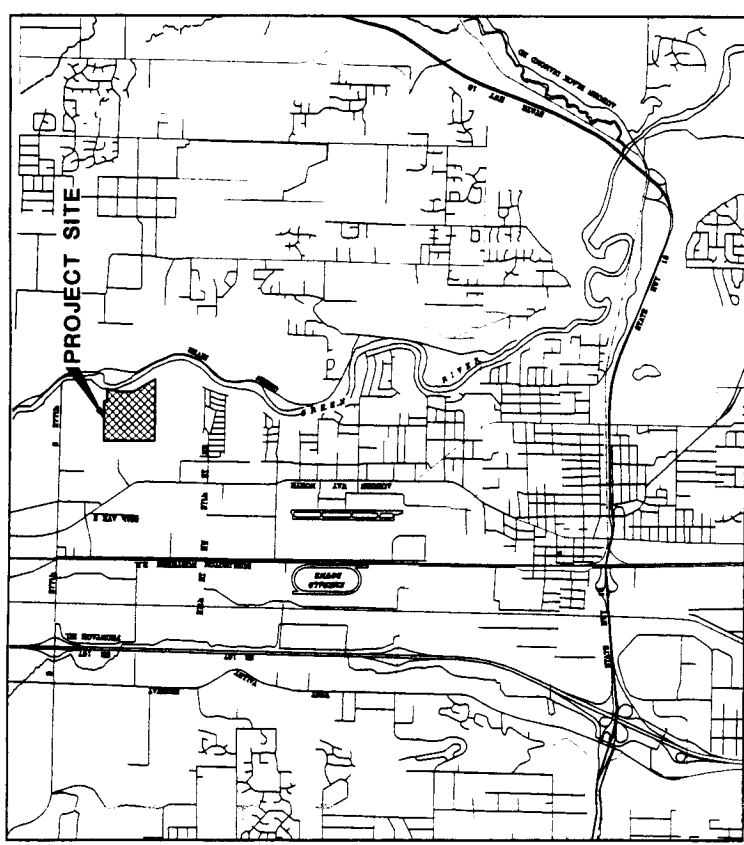
WORK ORDER NO. 100052  
PROJECT NO. STA-9804-11  
APPENDIX E

MAJOR CONTRACT RECOMMENDED FOR APPROVAL  
APPROVED BY  
DATE

### GENERAL LEGEND



KEY NOTE NUMBER REFERENCE THAT CORRELATES NOTE CALLOUT TO NOTE THAT APPLIES.



VICINITY MAP



### GENERAL ABBREVIATIONS

|            |                           |               |                         |
|------------|---------------------------|---------------|-------------------------|
| ALUM       | ALUMINUM                  | D.C.          | ON CENTER CONCENTRATION |
| AL         | ALUMINUM                  | D.C.C.        | ON CENTER CONCENTRATION |
| CP         | COMPRESSIVE STRENGTH      | PE            | POLYETHYLENE            |
| CMP        | CORRUGATED METAL PIPE     | PVC           | POLYVINYL CHLORIDE      |
| CONC       | CONCRETE                  | P             | PROPERTY LINE           |
| CONC       | CONTINUOUS                | P             | POUNDS PER SQUARE INCH  |
| CUB        | CUBIC FOOT                | REQ'D         | REQUIRED                |
| DCVA       | DIRECT CURRENT VOLTAGE    | S             | SOUTH                   |
| DEG        | DEGREE                    | SCH           | SCHEDULE                |
| DIA        | DIAMETER                  | ST            | STAINLESS STEEL         |
| EA         | EACH                      | ST            | STEEL                   |
| EL OR ELEV | ELEVATION                 | TYP           | TYPICAL                 |
| EXIST      | EXISTING                  | V             | VERTICAL                |
| EXST       | EXISTING                  | VERT OR V     | VERTICAL                |
| FT         | FOOT (FEET)               | W             | WATER                   |
| FT         | FOOT (FEET)               | WL            | WATER LEVEL             |
| FT         | FOOT (FEET)               | Y             | YIELD STRENGTH          |
| GPM        | GALLONS PER MINUTE        | Y             | YIELD STRENGTH          |
| GHS        | HIGH DENSITY POLYETHYLENE | AT            | AT WATERLINE            |
| HDPE       | HIGH DENSITY POLYETHYLENE | INCHES        | INCHES                  |
| HP         | HORSEPOWER                | FEET          | FEET                    |
| INCH       | INCHES                    | AND           | AND                     |
| INCH       | INCHES                    | PERCENT       | PERCENT                 |
| KIP        | KIPS PER SQUARE INCH      | DEGREES       | DEGREES                 |
| LF         | LINEAR FEET/FOOT          | PLUS OR MINUS | PLUS OR MINUS           |
| MAX        | MAXIMUM                   |               |                         |
| MIN        | MINIMUM                   |               |                         |
| M          | MINUTE                    |               |                         |
| N.T.S.     | NOT TO SCALE              |               |                         |
| N.I.C.     | NOT IN CONTRACT           |               |                         |
| NE         | NORTHEAST                 |               |                         |
| NW         | NORTHWEST                 |               |                         |

### NOTES

1. THE APPROXIMATELY 67-ACRE PROJECT SITE IS LOCATED IN THE NORTHWEST CORNER OF THE 100-ACRE, RANGE 10 EAST, WILLAMETTE MERIDIAN, KING COUNTY, WASHINGTON.
2. TOPOGRAPHIC BASEMAP FOR PLAN SHEETS WAS OBTAINED FROM THE WASHINGTON STATE DEPARTMENT OF ECOLOGY AND FISHeries SUPPLEMENTAL CONTOURS WITHIN THE PROJECT AREA AS OBTAINED FROM A FIELD PARAMETRIX IN 1995 WITH ADDITIONAL SURVEY IN 1998, 1997 AND 1998.

AGENCY REVIEW  
NOT FOR CONSTRUCTION

Part of Seattle SEA-TAC INTERNATIONAL AIRPORT ALBUHURN WETLAND MITIGATION VICINITY MAP, SYMBOLS, NOTES AND ABBREVIATIONS

|                |                                                |
|----------------|------------------------------------------------|
| PROJECT NUMBER | 100053                                         |
| CONTRACT NO.   | 291214C1-2                                     |
| SHEET TITLE    | VICINITY MAP, SYMBOLS, NOTES AND ABBREVIATIONS |
| DATE           | STIA-9804-C1                                   |

CALL 48 HOURS BEFORE YOU DIG 1-800-474-555

Parametrix, Inc.  
5808 1st Washington Blvd. NE  
Kirkland, WA 98033  
Ph: (425) 822-8800

Quality Services Through Employee Ownership

| NO. | DATE | BY | REVISIONS |
|-----|------|----|-----------|
|     |      |    |           |
|     |      |    |           |

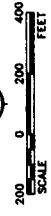
SCALE: 1" = 400' AT 11" X 17" SCALE  
1" = 800' AT 8 1/2" X 11" SCALE

**NOTES:**

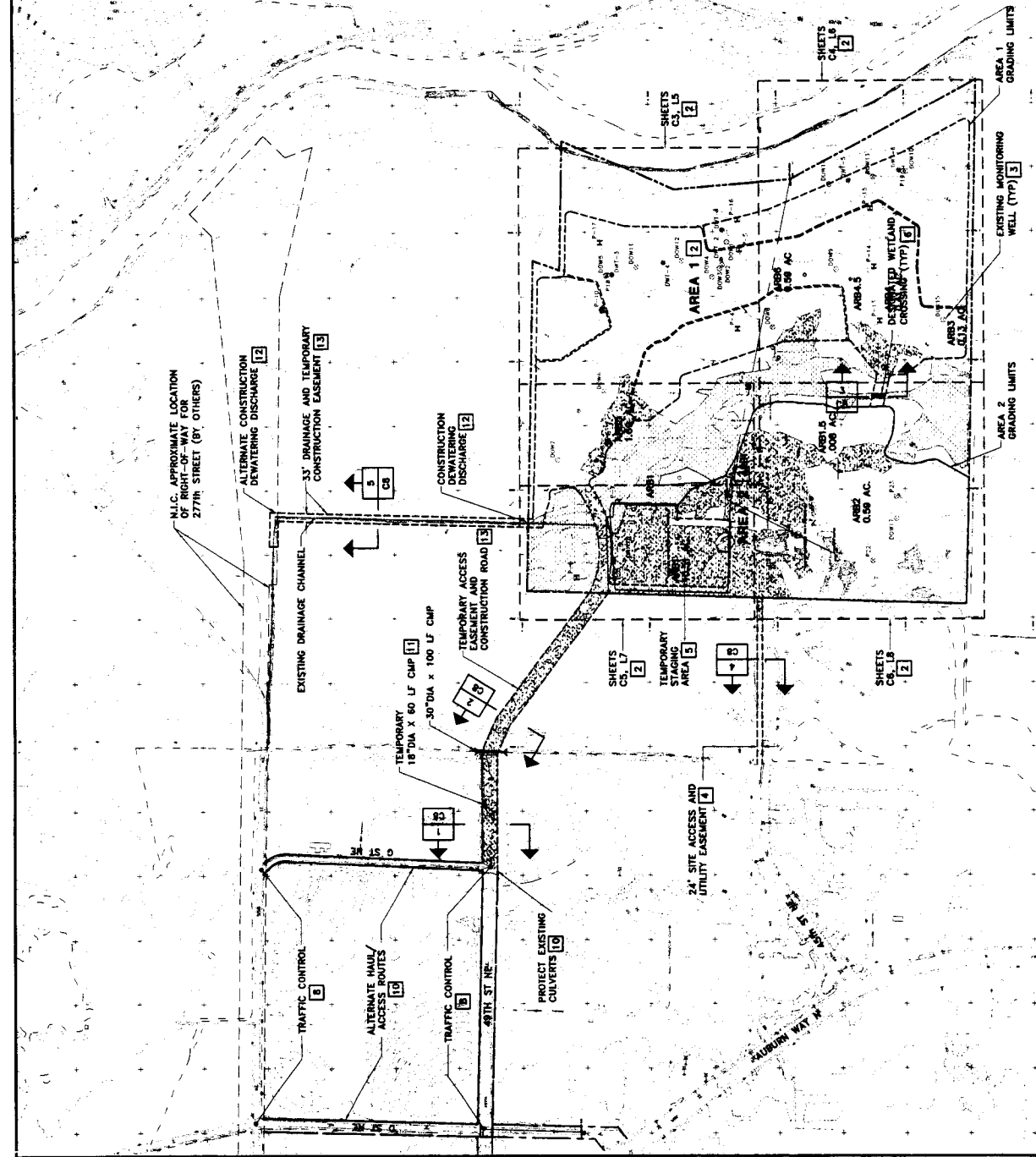
1. PROVIDE TEMPORARY EROSION AND SEDIMENT CONTROLS PER SHEET T-1 PRIOR TO ANY EARTHWORK. NO CONSTRUCTION ACTIVITIES SHALL OCCUR OUTSIDE OF APPROVED RIGHT-OF-WAY. CONSTRUCTION EASEMENTS SHALL BE MAINTAINED THROUGHOUT CONSTRUCTION. WETLAND CROSSINGS, GRADING LIMITS, OR APPROVED DISCHARGE POINT.
2. CONSTRUCTION PHASING: AREA 1 EARTHWORK SHALL BE COMPLETED PRIOR TO BEGINNING AREA 2 EARTHWORK. AREA 1 GRADING WILL LIKELY OCCUR 1 YEAR BEFORE AREA 2 GRADING.
3. PROTECT EXISTING WELLS PER SPECIFICATIONS. ABANDON WELLS UPON COMPLETION OF PHASED CONSTRUCTION AS SPECIFIED.
4. PROVIDE TEMPORARY ELECTRIC SERVICE AND IRRIGATION LINE PER SPECIFICATIONS. EASEMENT TO BE STAKED BY ENGINEER.
5. STAGING AREA SHALL BE GRADED LEVEL AS NEEDED FOR CONTRACTOR STORAGE AND EQUIPMENT. STAGING AREA SHALL BE DESIGNED AND MAINTAINED BY THE CONTRACTOR. ADDITIONAL STAGING FOR STOCKPILING SHALL BE MADE AVAILABLE WITHIN LIMITED PORTIONS OF PHASE 2 GRADING LIMITS UPON SUBMITTAL REQUEST AND APPROVAL PROCESS.
6. NO CONSTRUCTION ACTIVITIES OR DISTURBANCE SHALL OCCUR IN EXISTING WETLAND AREAS EXCEPT FOR DESIGNATED WETLAND CROSSING AREAS. WITHIN GRADING LIMITS AND ACCESS ROUTES, ANY DISTURBANCE SHALL BE FIELD MONITORED AND REPAIRED PRIOR TO INSTALLATION OF ABOVE GROUND IRRIGATION AND PLANT MATERIAL.
7. ALL DISTURBED AREAS SHALL BE HYDROMULCH SEEDS PER SPECIFICATIONS UNLESS OTHERWISE INDICATED ON THE PLANS OR AS DIRECTED BY THE ENGINEER.
8. PROVIDE TRAFFIC CONTROL AT INTERSECTIONS PER SPECIFICATIONS.
9. ALTERNATE CONSTRUCTION ACCESS/HAUL ROUTES SHALL BE PER AGREEMENT WITH CITY. SEE SPECIFICATIONS.
10. PROTECT EXISTING CULVERTS, FENCE AND LANDSCAPE PLANTINGS.
11. TEMPORARY CMP TO BE FIELD STAKED BY ENGINEER. REMOVE AT END OF PROJECT.
12. CONSTRUCTION DEWATERING WATER SHALL BE DISCHARGED TO EXISTING SURFACE WATER DITCH. ALTERNATE DISCHARGE POINT AT 277TH STREET STORM DRAIN TO BE USED ONLY WITH APPROVAL FROM CITY OF AUBURN.
13. TEMPORARY WETLAND IMPACTS IN ACCESS ROADS WILL BE RESTORED AND HYDROSEEDED WITH EMERGENT WETLAND COMMUNITY. SEE SHEET L-B.

**LEGEND**

- PROPERTY BOUNDARY
- 100' BUFFER LINE
- GRADING LIMITS
- HAUL ACCESS ROUTES
- GRAVEL PATH
- EXISTING WETLAND BOUNDARY
- EXISTING WETLANDS IN PROJECT AREA
- WETLAND CROSSING AREA WITH CULVERTS
- EXISTING WETLANDS TO BE MODIFIED
- EXISTING DEWATERING OBSERVATION WELL
- EXISTING DEWATERING TEST WELL
- EXISTING MONITORING WELL
- TEST PIT LOCATION



**AGENCY REVIEW  
NOT FOR CONSTRUCTION**



**Call 48 hours before you dig**  
1-800-424-5555

**Parametrix, Inc.**  
5808 1st. Washington Blvd. NE  
Kirkland, WA 98033  
Ph: (425) 822-8880

*"Quality Service Through Employee Ownership"*

**2812148A**

DATE: 11/12/07    DRAWN: 2812147C    CHECKED: 2812148A    2812147C

PROJECT: **SEA-TAC INTERNATIONAL AIRPORT  
AUBURN WETLAND MITIGATION**

SHEET NO: **281214C2**

DATE OF ISSUE: **10/05/07**

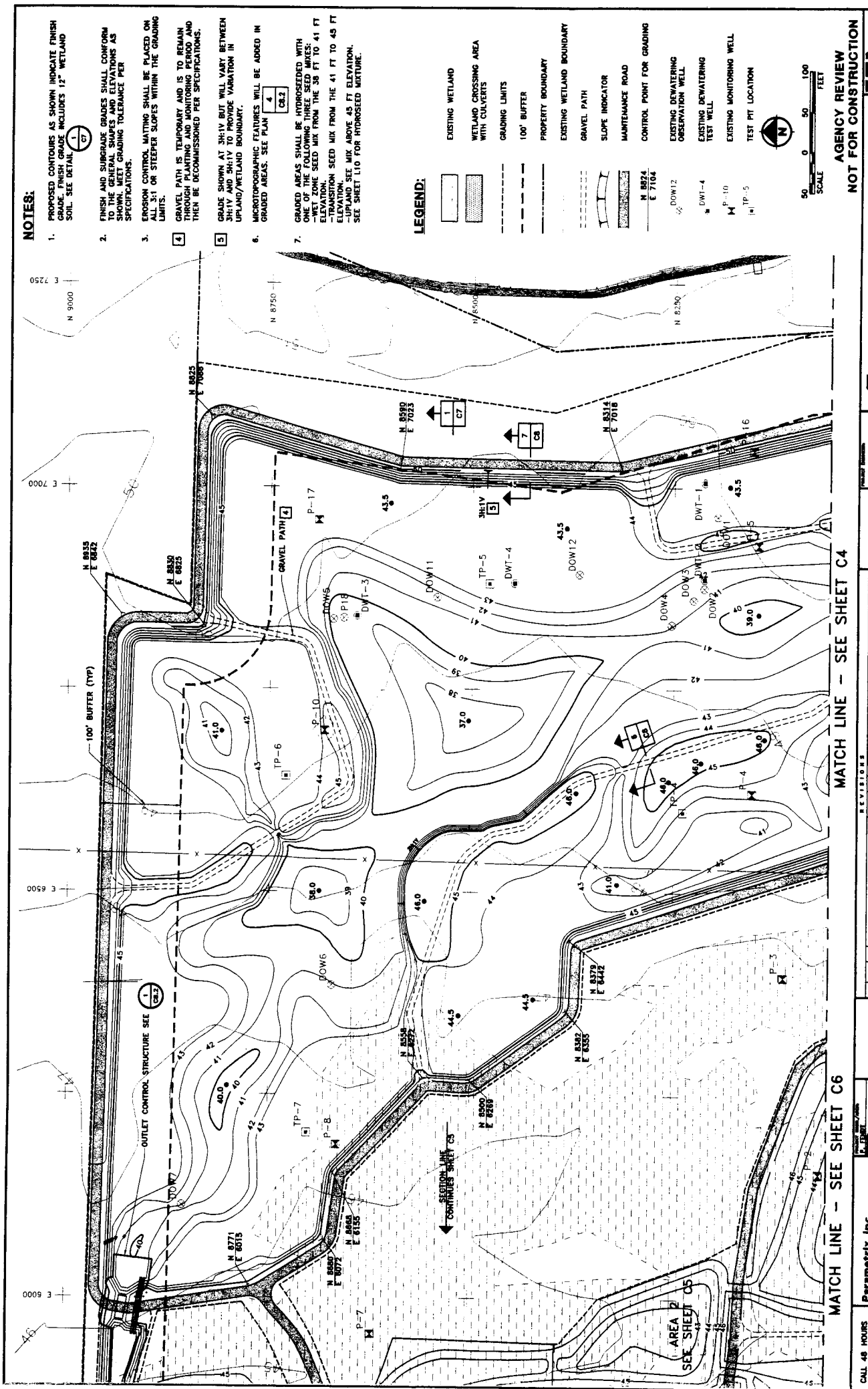
PROJECT NO: **100052**

CONTRACT NO: **281214C2**

STA: **9804-C2**

APPENDIX **E**

AR 049499

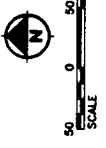


**NOTES:**

- PROPOSED CONTOURS AS SHOWN INDICATE FINISH GRADE. FINISH GRADE INCLUDES 12" WETLAND SOIL. SEE DETAIL C1.
- FINISH AND SUBGRADE GRADES SHALL CONFORM TO THE FINISH GRADES AND ELEVATIONS AS SHOWN. MEET GRADING TOLERANCE PER SPECIFICATIONS.
- EROSION CONTROL MATTING SHALL BE PLACED ON SLOPE SET ON STEEPER SLOPES WITHIN THE GRADING LIMITS.
- GRAVEL PATH IS TEMPORARY AND IS TO REMAIN THROUGH PLANTING AND MONITORING PERIOD AND THEN BE DECOMMISSIONED PER SPECIFICATIONS.
- GRADE SHOWN AT 3H:1V BUT WILL VARY BETWEEN 3H:1V AND SH:1V TO PROVIDE VARIATION IN UPLAND/WETLAND BOUNDARY.
- MICROTOPOGRAPHIC FEATURES WILL BE ADDED IN GRADED AREAS. SEE PLAN C2.
- GRADED AREAS SHALL BE HYDROSEED WITH ONE OF THE FOLLOWING THREE SEED MIXES:
  - ELEVATION SEED MIX FROM THE 38 FT TO 41 FT
  - TRANSITION SEED MIX FROM THE 41 FT TO 43 FT
  - ELEVATION SEED MIX ABOVE 43 FT ELEVATION. SEE SHEET L10 FOR HYDROSEED MIXTURE.

**LEGEND:**

- EXISTING WETLAND
- WETLAND CROSSING AREA WITH CULVERTS
- GRADING LIMITS
- 100' BUFFER
- PROPERTY BOUNDARY
- EXISTING WETLAND BOUNDARY
- GRAVEL PATH
- SLOPE INDICATOR
- MAINTENANCE ROAD
- CONTROL POINT FOR GRADING
- EXISTING DOWATERING OBSERVATION WELL
- EXISTING DOWATERING TEST WELL
- EXISTING MONITORING WELL
- TEST PIT LOCATION



MATCH LINE - SEE SHEET C4

MATCH LINE - SEE SHEET C6

DATE: 11/9/01 PROJECT: PHASE I GRADING PLAN NE SHEET NO. 281214C3 281214C3 STA-9804-C3

**AGENCY REVIEW NOT FOR CONSTRUCTION**

---

**Part of Seattle BEA-TAC INTERNATIONAL AIRPORT AUBURN WETLAND MITIGATION PROJECT**

**PHASE I GRADING PLAN NE**

---

DATE: 11/9/01 PROJECT: PHASE I GRADING PLAN NE SHEET NO. 281214C3 281214C3 STA-9804-C3

---

CALL 48 HOURS BEFORE YOU DIG 1-800-424-3555

---

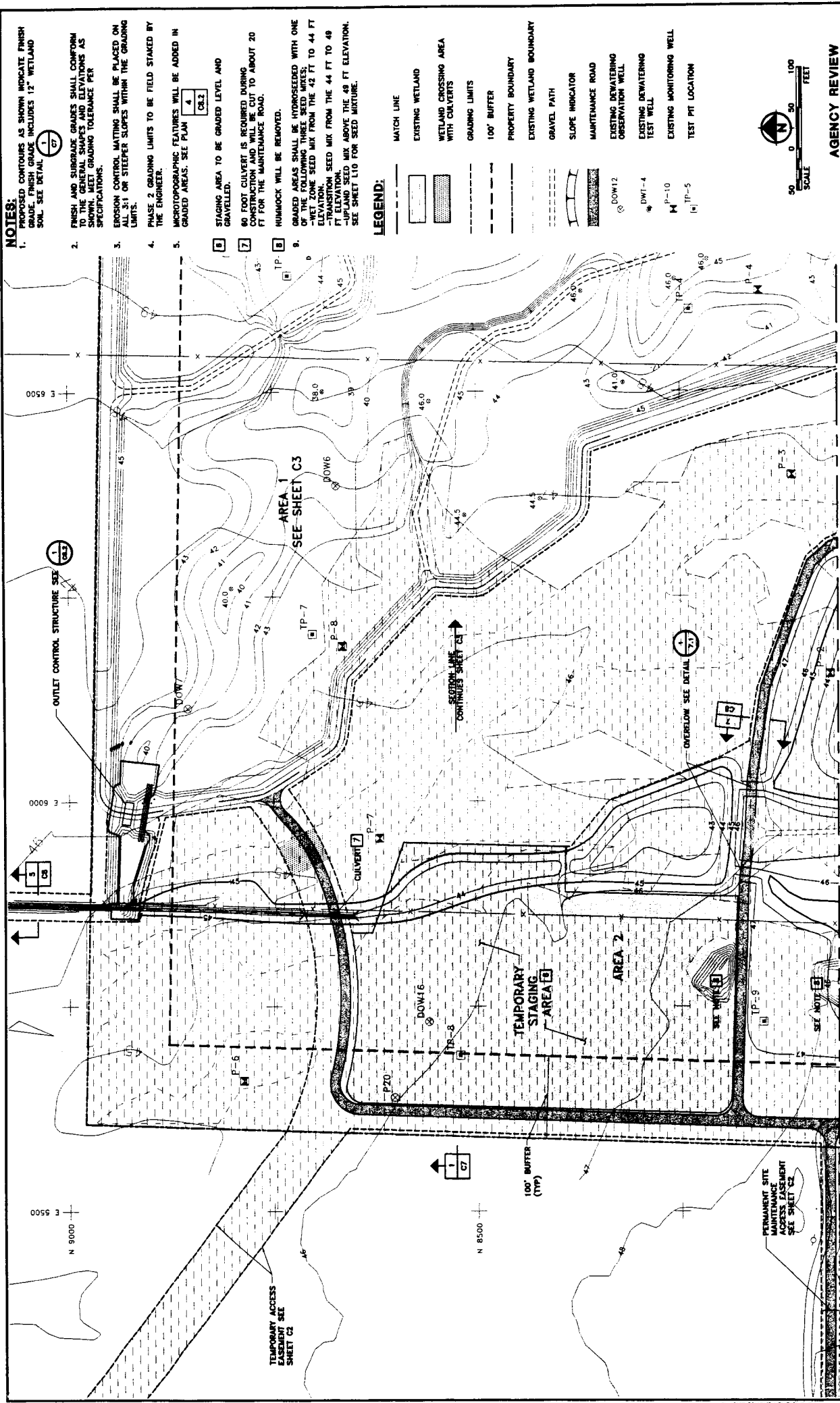
**Paramatrix, Inc.**  
 5808 Lk. Washington Blvd. NE  
 Kirkland, WA 98033  
 Ph: (425) 822-6880

---

QUALITY SERVICE THROUGH EXCELLENCE







**NOTES:**

1. FINISHED CONTOURS AS SHOWN INDICATE FINISH GRADE. FINISH GRADE INCLUDES 12" WETLAND SOIL. SEE DETAIL (C7).
2. FINISH AND SURGRADE GRADES SHALL CONFORM TO THE GENERAL SHAPES AND ELEVATIONS AS SHOWN. MEET GRADING TOLERANCE PER SPECIFICATIONS.
3. EROSION CONTROL MATTING SHALL BE PLACED ON ALL 3:1 OR STEEPER SLOPES WITHIN THE GRADING LIMITS.
4. PHASE 2 GRADING LIMITS TO BE FIELD STAKED BY THE ENGINEER.
5. MICROTOPOGRAPHIC FEATURES WILL BE ADDED IN GRADED AREAS. SEE PLAN (C8.2).

6. STAGING AREA TO BE GRADED LEVEL AND GRAVELLED.
7. 60 FOOT CULVERT IS REQUIRED DURING CONSTRUCTION AND WILL BE CUT TO ABOUT 20 FT FOR THE MAINTENANCE ROAD.
8. HUMMOCK WILL BE REMOVED.
9. GRADED AREAS SHALL BE HYDROSEED WITH ONE PART SEED MIX FROM THE 42 FT TO 44 FT ELEVATION.  
 -WET ZONE SEED MIX FROM THE 42 FT TO 44 FT ELEVATION.  
 -TRANSITION SEED MIX FROM THE 44 FT TO 48 FT ELEVATION.  
 -DOWNSIDE SEED MIX ABOVE THE 48 FT ELEVATION.  
 SEE SHEET L10 FOR SEED MIXTURE.

- LEGEND:**
- MATCH LINE
  - EXISTING WETLAND
  - WETLAND CROSSING AREA WITH CULVERTS
  - GRADING LIMITS
  - 100' BUFFER
  - PROPERTY BOUNDARY
  - EXISTING WETLAND BOUNDARY
  - GRAVEL PATH
  - SLOPE INDICATOR
  - MAINTENANCE ROAD
  - EXISTING DEWATERING OBSERVATION WELL
  - EXISTING DEWATERING TEST WELL
  - EXISTING MONITORING WELL
  - TEST PIT LOCATION



**AGENCY REVIEW**  
**NOT FOR CONSTRUCTION**

Part of Seattle SEA-TAC INTERNATIONAL AIRPORT ALBUQUERQUE WETLAND MITIGATION  
 SHEET NO. PHASE 2 GRADING PLAN NW  
 DATE: 08/11/07  
 PROJECT NO. 28121.4C5  
 DRAWING NO. STA-8804-C5  
 APPENDIX E

| NO. | DATE | BY | REVISIONS |
|-----|------|----|-----------|
|     |      |    |           |
|     |      |    |           |
|     |      |    |           |
|     |      |    |           |

APPROVED FOR CONSTRUCTION  
 DATE: 08/11/07  
 PROJECT NO. 28121.4C5  
 DRAWING NO. STA-8804-C5  
 APPENDIX E

**Parametrix, Inc.**  
 6808 L.L. Washburn Blvd. NE  
 Redmond, WA 98073  
 PH: (425) 822-8800  
 "Quality Service Through Employee Ownership"

CALL US NOW  
 BEFORE YOU GO  
 1-800-424-5555

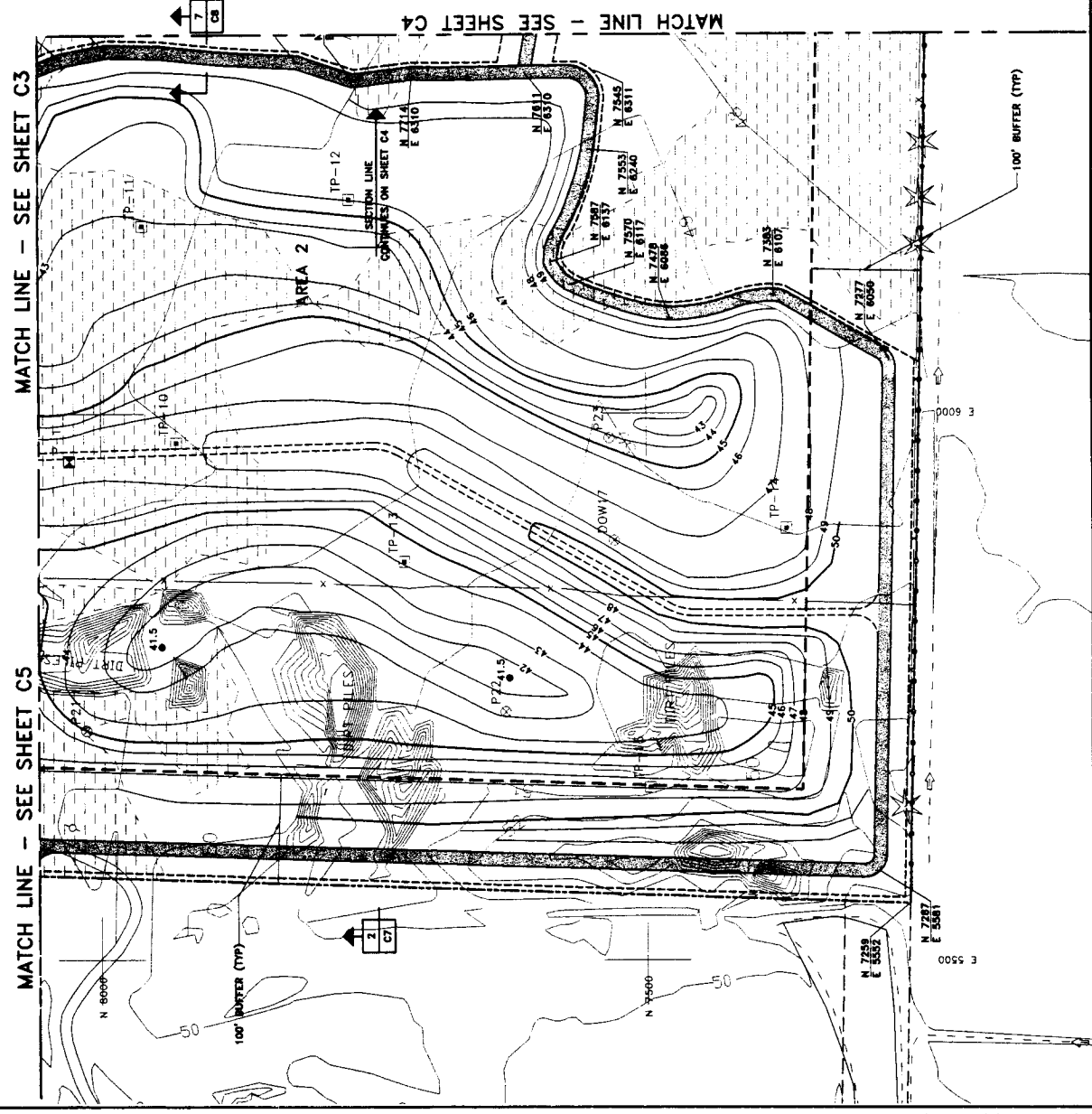
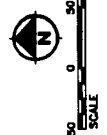
DATE: 11/14/07  
 PROJECT: PHASE 2 GRADING PLAN NW  
 SHEET: STA-8804-C5  
 APPENDIX E

**NOTES:**

1. PROPOSED CONTOURS AS SHOWN INDICATE FINISH GRADE. FINISH GRADE INCLUDES 12" WETLAND SOIL. SEE DETAIL (1) (C).
2. FINISH AND SURFACE GRADES SHALL CONFORM WITH THE SURFACE GRADES AND ELEVATIONS AS SHOWN. MEET GRADING TOLERANCE PER SPECIFICATIONS.
3. EROSION CONTROL MATING SHALL BE PLACED ON ALL SLOPE OR STEEPER SLOPES WITHIN THE GRADING LIMITS.
4. PHASE 2 GRADING LIMITS TO BE FIELD STAKED BY THE ENGINEER.
5. MICROTOPOGRAPHIC FEATURES WILL BE ADDED IN GRADED AREAS. SEE PLAN (4) (C2.2).
6. GRADED AREAS SHALL BE HYDROSEEDED WITH ONE OF THE FOLLOWING THREE SEED MIXES:  
 -WETLAND SEED MIX FROM THE 36 FT TO 41 FT ELEVATION.  
 -TRANSITION SEED MIX FROM THE 41 FT TO 45 FT ELEVATION.  
 -UPLAND SEED MIX ABOVE THE 45 FT ELEVATION. SEE SHEET L10 FOR SEED MIXTURE.

**LEGEND:**

- MATCHLINE
- EXISTING WETLAND
- WETLAND CROSSING
- GRADING LIMITS
- 100' BUFFER
- PROPERTY BOUNDARY
- EXISTING WETLAND BOUNDARY
- GRAVEL PATH
- SLOPE INDICATOR
- MAINTENANCE ROAD
- CONTROL POINT FOR GRADING
- EXISTING DEWATERING OBSERVATION WELL
- EXISTING DEWATERING TEST WELL
- EXISTING MONITORING WELL
- TEST PIT LOCATION



**AGENCY REVIEW**  
**NOT FOR CONSTRUCTION**

**Port of Seattle**  
**SEA-TAC INTERNATIONAL AIRPORT**  
**AUBURN WETLAND MITIGATION**  
**PHASE 2 GRADING PLAN SW**

|             |                               |
|-------------|-------------------------------|
| PROJECT NO. | 28121406                      |
| DATE        | 11/14/07                      |
| SCALE       | AS SHOWN                      |
| PROJECT     | SEA-TAC INTERNATIONAL AIRPORT |
| DESIGNER    | PARAMETRIX, INC.              |
| CHECKED BY  |                               |
| APPROVED BY |                               |

| NO. | DATE | BY | DESCRIPTION |
|-----|------|----|-------------|
|     |      |    |             |
|     |      |    |             |
|     |      |    |             |

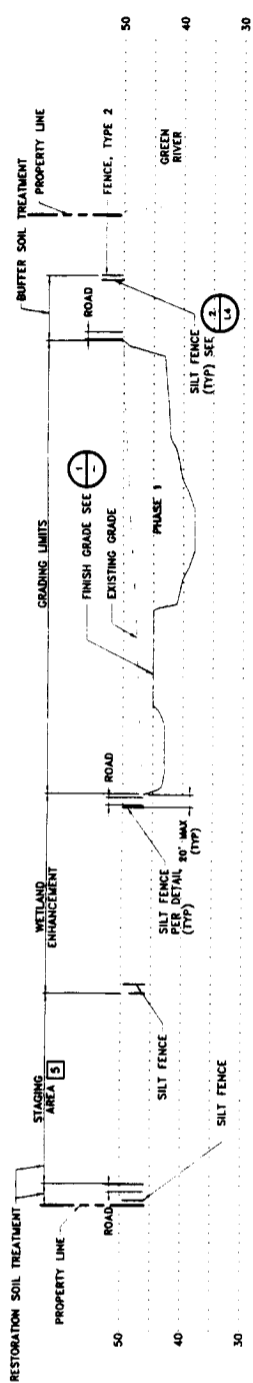
|             |                               |
|-------------|-------------------------------|
| DATE        | 11/14/07                      |
| PROJECT     | SEA-TAC INTERNATIONAL AIRPORT |
| DESIGNER    | PARAMETRIX, INC.              |
| CHECKED BY  |                               |
| APPROVED BY |                               |

**Parametrix, Inc.**  
 5908 Lk. Washington Blvd. NE  
 Kirkland, WA 98033  
 Ph: (425) 822-8800

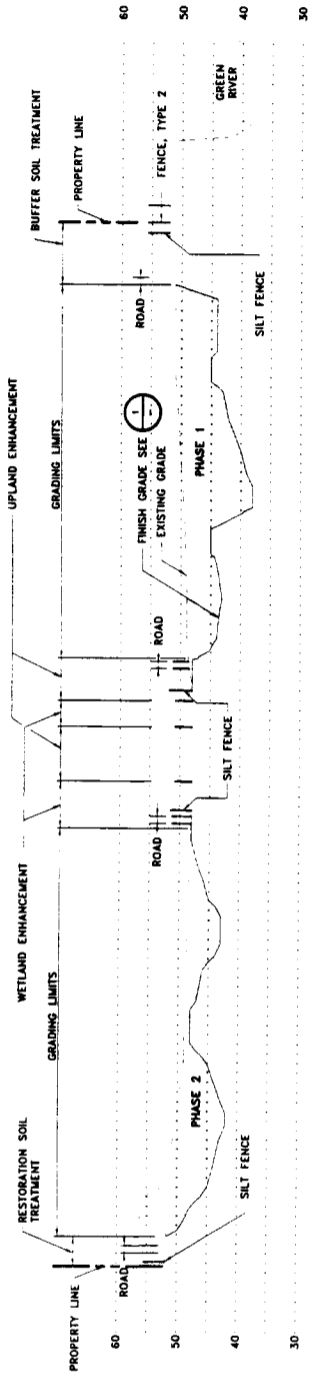
CALL 48 HOURS BEFORE YOU DIG  
 1-800-424-5555

DATE: 11/14/07  
 PROJECT: SEA-TAC INTERNATIONAL AIRPORT  
 SHEET: 28121406-08

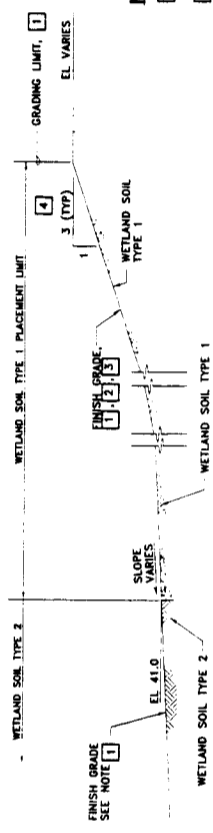
AR 049503



**SECTION 1**  
 HORIZ: 1"=100'  
 VERT: 1"=10'  
 1 C3 C5



**SECTION 2**  
 HORIZ: 1"=100'  
 VERT: 1"=10'  
 2 C4 C6

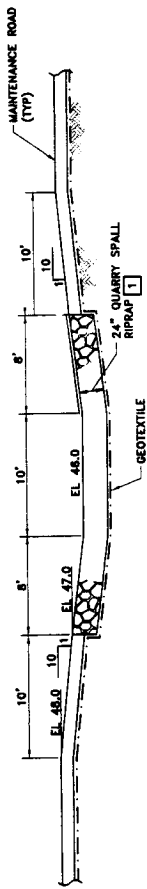


**DETAIL**  
 WETLAND SOIL PLACEMENT  
 SCALE: 1"=5'  
 1 C3, C4, C5, C6, L5, L6, L7, L8

- NOTES:**
- 1 GRADING LIMIT AND FINISHED GRADE AS SHOWN ON SHEETS C3, C4, C5, & C6.
  - 2 WETLAND SOIL TYPE 1 SHALL BE USED AT ELEVATION 41.0 AND ABOVE FOR ALL AREAS WITHIN THE GRADING LIMITS. WETLAND SOIL TYPE 2 SHALL BE PLACED BELOW ELEVATION 41.0 WITHIN THE AREA SHOWN ON THE PLAN.
  - 3 HYDROSED PER SHEET C9. PLACE EROSION CONTROL MATS AT ALL GRADING LIMITS. STEEPER SLOPES WITHIN THE GRADING LIMITS.
  - 4 GRADE SHOWN AT 10' INTERVALS. VARIATION IN UPLAND/WETLAND BOUNDARY.
  - 5 WETLANDS MODIFIED IN STAGING AREA WILL BE RESTORED THEN ENHANCED AFTER CONSTRUCTION IS COMPLETE.

**AGENCY REVIEW**  
**NOT FOR CONSTRUCTION**

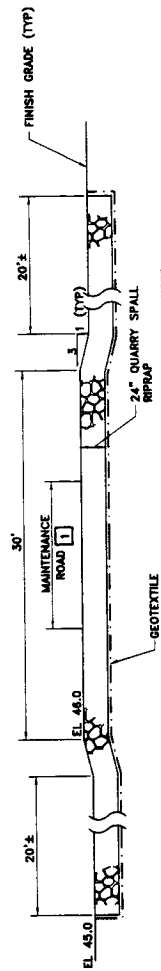
|                                                                                                                                                   |      |                                                  |             |
|---------------------------------------------------------------------------------------------------------------------------------------------------|------|--------------------------------------------------|-------------|
| <b>Paramatrix, Inc.</b><br>5808 Lt. Washington Blvd. NE<br>Kirkland, WA 98033<br>Ph: (425) 822-8880<br>Quality Service Through Employee Ownership |      | CALL 48 HOURS<br>TOLL FREE<br>1-800-424-3855     |             |
| PROJECT: BEA-TAC INTERNATIONAL AIRPORT<br>AUBURN WETLAND MITIGATION                                                                               |      | SHEET NO.: 281214C7<br>TOTAL SHEETS: 281214C7-01 |             |
| SHEET TITLE: SECTIONS AND DETAILS                                                                                                                 |      | STA: 8804-C7                                     |             |
| REVISIONS                                                                                                                                         |      |                                                  |             |
| NO.                                                                                                                                               | DATE | BY                                               | DESCRIPTION |
|                                                                                                                                                   |      |                                                  |             |
|                                                                                                                                                   |      |                                                  |             |
|                                                                                                                                                   |      |                                                  |             |



NOTE:  
 1 CHOKER THE UPPER 3" OF QUARRY SPALLS WITHIN THE MAINTENANCE ROAD WITH CRUSHED SURFACING.

**SECTION**  
 SCALE: 1"=5'

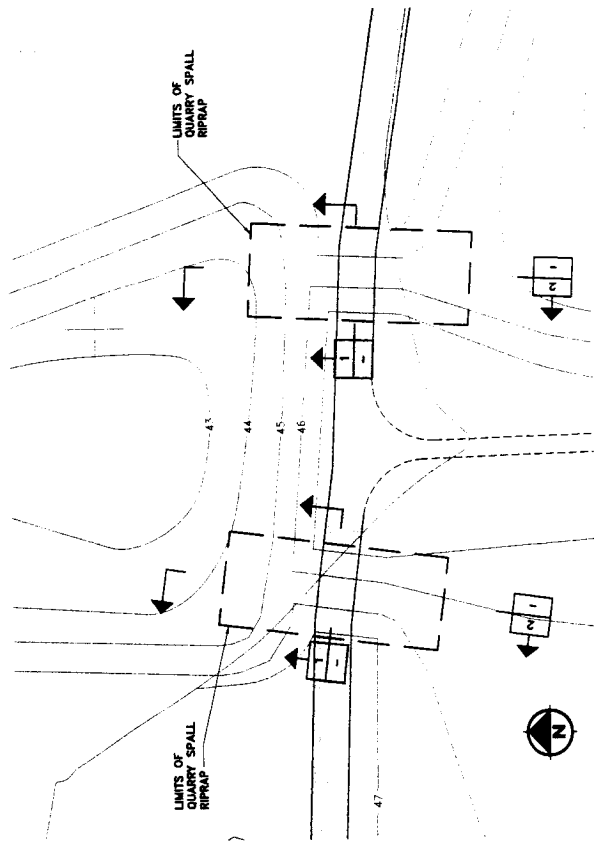
|   |   |
|---|---|
| 1 | - |
|---|---|



NOTE:  
 1 CHOKER THE UPPER 3" OF QUARRY SPALLS WITHIN THE MAINTENANCE ROAD WITH CRUSHED SURFACING.

**SECTION**  
 SCALE: 1"=5'

|   |   |
|---|---|
| 2 | - |
|---|---|



**DETAIL**  
 OVERFLOW PLAN  
 SCALE: 1"=20'

|   |    |
|---|----|
| 1 | CS |
|---|----|

CALL US  
 BEFORE YOU DIG  
 1-800-424-5555

**Parametrix, Inc.**

5808 Lt. Washington Blvd. NE  
 Kirkland, WA 98033  
 Ph: (425) 822-8890

Quality Service Through Employee Ownership

PROJECT: 28121407-1  
 SHEET NO: 9804-C7.1

DESIGNER:  
 CHECKER:  
 DATE:

| NO. | DATE | BY | CHK. | REV. | DESCRIPTION |
|-----|------|----|------|------|-------------|
|     |      |    |      |      |             |
|     |      |    |      |      |             |
|     |      |    |      |      |             |
|     |      |    |      |      |             |

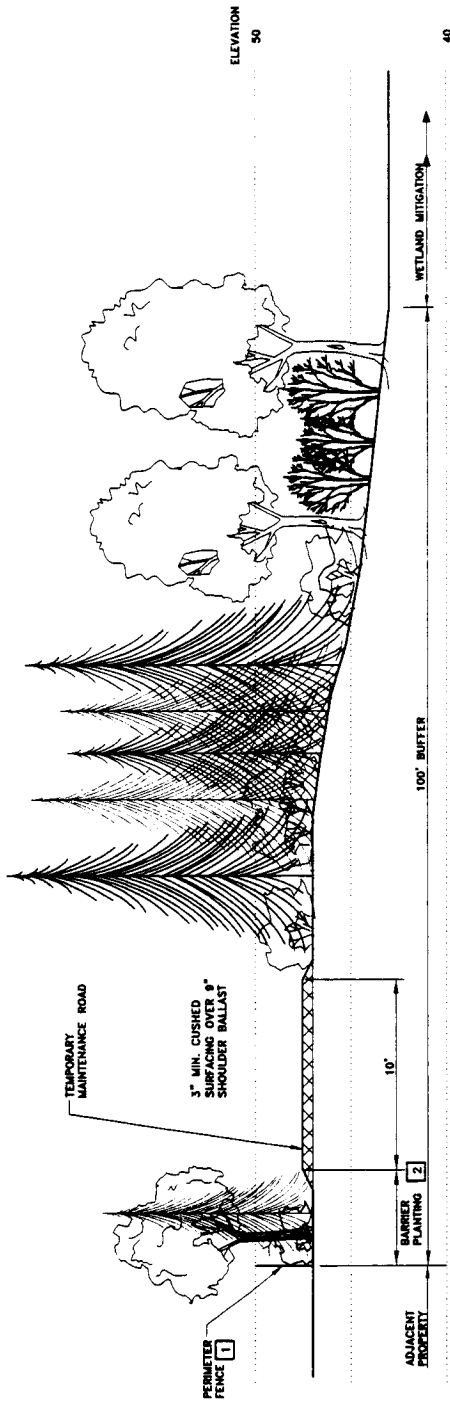
| NO. | DATE | BY | CHK. | REV. | DESCRIPTION |
|-----|------|----|------|------|-------------|
|     |      |    |      |      |             |
|     |      |    |      |      |             |
|     |      |    |      |      |             |
|     |      |    |      |      |             |

**Parametrix**  
 SEA-TAC INTERNATIONAL AIRPORT  
 AUBURN WETLAND MITIGATION  
 OVERFLOW SECTIONS AND DETAILS

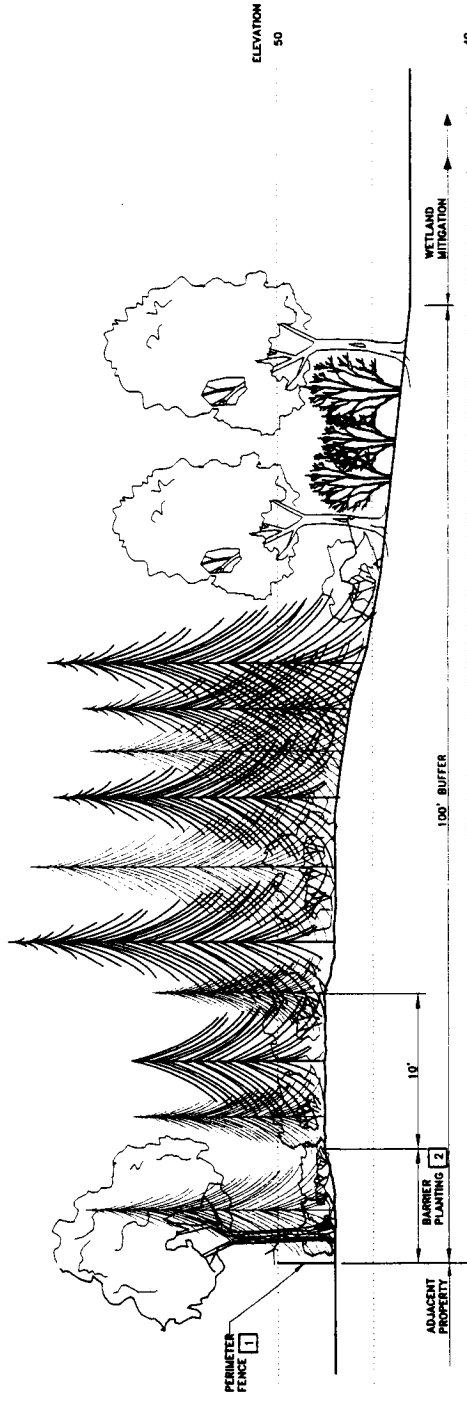
100052  
 28121407-1  
 STA-9804-C7.1  
 APPENDIX E



- NOTE:**  
 1] TEMPORARY SECURITY FENCE WILL BE INSTALLED DURING CONSTRUCTION AND REMOVED AFTER CONSTRUCTION. PERMANENT FENCE WILL BE INSTALLED AFTER CONSTRUCTION AND INITIAL PLANTING.  
 2] BARRIER PLANTINGS TO INCLUDE 20 PERCENT MORE SHRUBS THAN OTHER BUFFER AREAS.



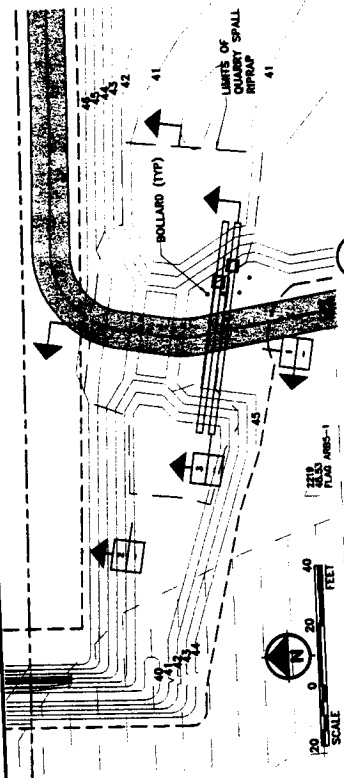
**DETAIL**  
 BARRIER PLANTING AND 100' WETLAND BUFFER  
 1 TYP  
 NOT TO SCALE



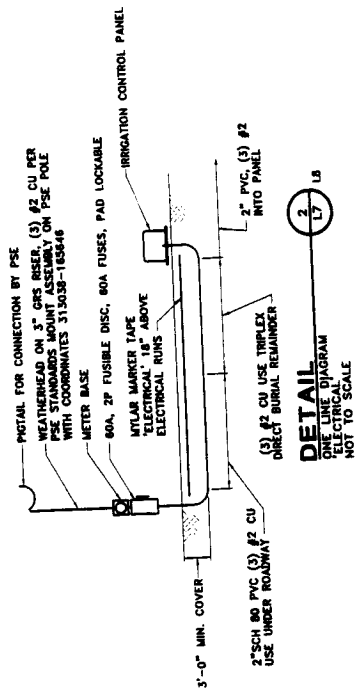
**DETAIL**  
 POST CONSTRUCTION BARRIER PLANTING AND 100' WETLAND BUFFER  
 2 TYP  
 NOT TO SCALE

**AGENCY REVIEW**  
 NOT FOR CONSTRUCTION

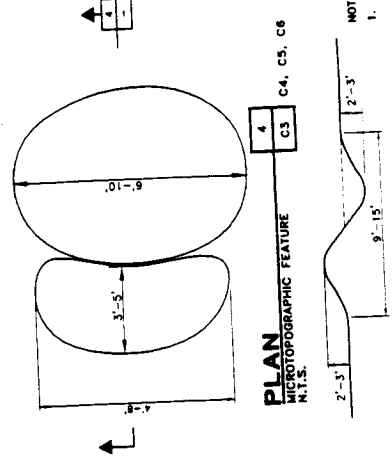
|                                                                                                                                                 |                                                                                                     |                                              |                                                                         |      |                                                                         |                          |                          |
|-------------------------------------------------------------------------------------------------------------------------------------------------|-----------------------------------------------------------------------------------------------------|----------------------------------------------|-------------------------------------------------------------------------|------|-------------------------------------------------------------------------|--------------------------|--------------------------|
| <b>CALL 48 HOURS BEFORE YOU DIG</b><br>1-800-424-5555                                                                                           | <b>Parametrix, Inc.</b><br>5908 Lt. Washington Blvd. NE<br>Kirkland, WA 98033<br>Ph: (425) 822-0800 | "Quality Service Through Employee Ownership" | <b>REVISIONS</b>                                                        |      | PROJECT NO.<br>100002                                                   | SHEET NO.<br>28121 ACB.1 | DATE PLOTTED<br>07/10/01 |
|                                                                                                                                                 |                                                                                                     |                                              | NO.                                                                     | DATE |                                                                         |                          |                          |
| PROJECT NAME: SEA-TAC INTERNATIONAL AIRPORT<br>PRODUCT: AUBURN WETLAND MITIGATION<br>SHEET TITLE: BUFFER AND TEMPORARY MAINTENANCE ROAD PROFILE |                                                                                                     |                                              | PROJECT NO.: 100002<br>SHEET NO.: 28121 ACB.1<br>DATE PLOTTED: 07/10/01 |      | PROJECT NO.: 100002<br>SHEET NO.: 28121 ACB.1<br>DATE PLOTTED: 07/10/01 |                          | STA: 9804+00.1           |



**DETAIL**  
**UNDERFLOW AND WATER LEVEL CONTROL STRUCTURES - PLAN**  
 1-4=20



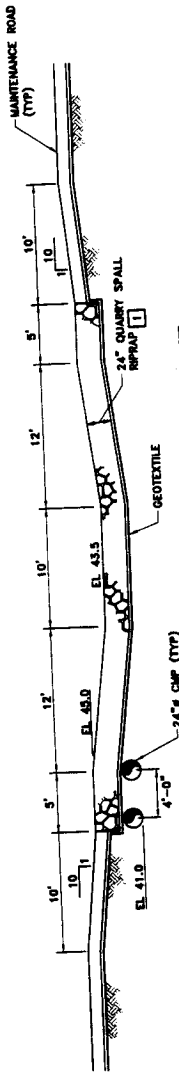
**DETAIL**  
 UNDERFLOW AND WATER LEVEL CONTROL STRUCTURES - SECTION



**PLAN**  
 MICROTOPOGRAPHIC FEATURE  
 N.T.S.

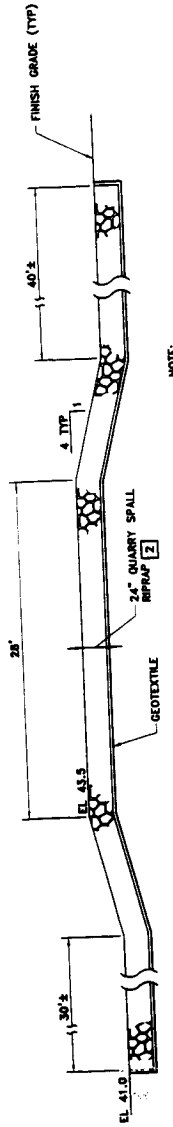
**SECTION**  
 MICROTOPOGRAPHIC FEATURE  
 N.T.S.

NOTE:  
 1. APPROXIMATELY 4 MICROTOPOGRAPHIC FEATURES PER ACRE.



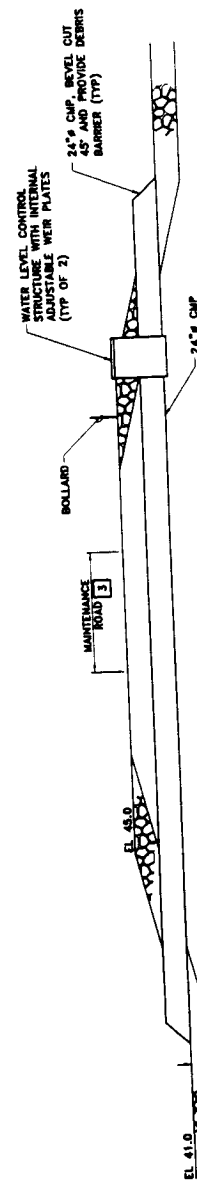
NOTE:  
 1. CHOKEN THE UPPER 3" OF QUARRY SPALLS WITHIN THE MAINTENANCE ROAD LIMITS WITH CRUSHED SURFACING. TAPER MAINTENANCE ROAD INTO QUARRY SPALL LIMITS.

**SECTION**  
 OVERFLOW SPILLWAY  
 1-4=5



NOTE:  
 2. CHOKEN THE UPPER 3" OF QUARRY SPALLS WITHIN THE MAINTENANCE ROAD LIMITS WITH CRUSHED SURFACING. TAPER MAINTENANCE ROAD INTO QUARRY SPALL LIMITS.

**SECTION**  
 OVERFLOW SPILLWAY  
 1-4=5



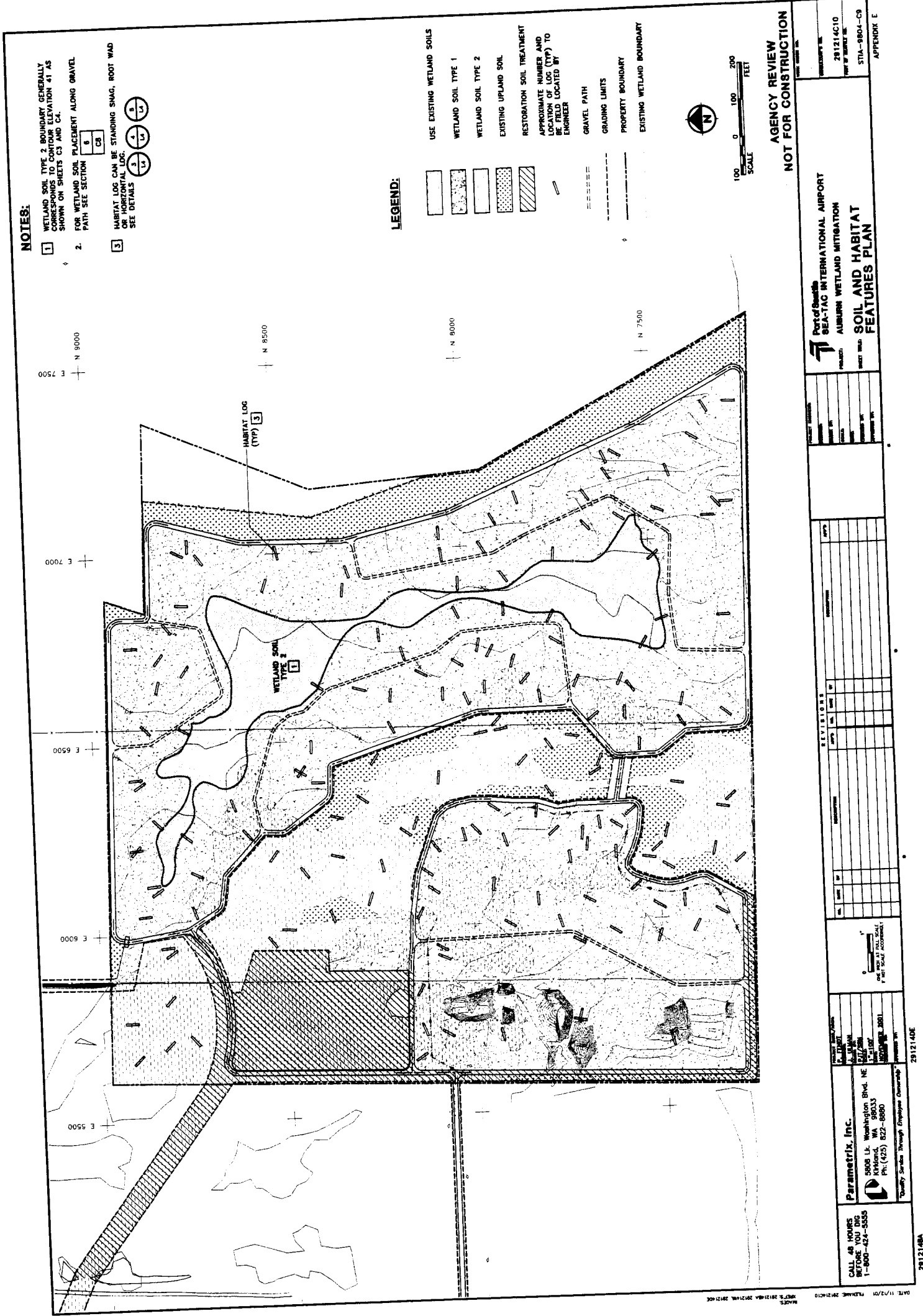
NOTE:  
 3. CHOKEN THE UPPER 3" OF QUARRY SPALLS WITHIN THE MAINTENANCE ROAD LIMITS WITH CRUSHED SURFACING. TAPER MAINTENANCE ROAD INTO QUARRY SPALL LIMITS.

**SECTION**  
 WATER LEVEL CONTROL STRUCTURE (TYP)  
 1-4=5

**AGENCY REVIEW**  
**NOT FOR CONSTRUCTION**

|                                                                                                                               |  |                                                                                                     |  |                                            |  |
|-------------------------------------------------------------------------------------------------------------------------------|--|-----------------------------------------------------------------------------------------------------|--|--------------------------------------------|--|
| CALL 48 HOURS BEFORE YOU START<br>1-800-427-5355                                                                              |  | Parametrix, Inc.<br>5808 1/2 Washington Blvd. NE<br>Redmond, WA 98033<br>Ph: (425) 872-8880         |  | Quality Service Through Employee Ownership |  |
| Project: 28121400<br>Title: SEA-TAC INTERNATIONAL AIRPORT AUBURN WETLAND MITIGATION<br>Sheet No.: 28121400-2<br>STA-9804-C8.2 |  | Date: 02/08/00<br>Author: J. BROWN<br>Designer: J. BROWN<br>Checker: J. BROWN<br>Engineer: J. BROWN |  | Revision:                                  |  |
| Scale: 1"=20'<br>0 20 40 FEET                                                                                                 |  | Project No.: 28121400-2<br>Drawing No.: STA-9804-C8.2                                               |  | Revision:                                  |  |
| Date: 11/15/99<br>PLOTTED: 02/08/00 09:21 AM<br>PLOT FILE: 28121400-2.dwg                                                     |  | Project No.: 28121400-2<br>Drawing No.: STA-9804-C8.2                                               |  | Revision:                                  |  |



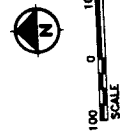


**NOTES:**

- 1 WETLAND SOIL TYPE 2 BOUNDARY GENERALLY CORRESPONDS TO CONTOUR ELEVATION 41 AS SHOWN ON SHEETS C3 AND C4.
- 2 FOR WETLAND SOIL PLACEMENT ALONG GRAVEL PATH SEE SECTION C3
- 3 HABITAT LOG CAN BE STANDING SWAG, ROOT WAD OR GRAVEL LOG. SEE DETAILS.

**LEGEND:**

- USE EXISTING WETLAND SOILS
- WETLAND SOIL TYPE 1
- WETLAND SOIL TYPE 2
- EXISTING UPLAND SOIL
- RESTORATION SOIL TREATMENT
- APPROXIMATE NUMBER AND LOCATION OF LOG (TYP) TO BE FIELD LOCATED BY ENGINEER
- GRAVEL PATH
- GRADING LIMITS
- PROPERTY BOUNDARY
- EXISTING WETLAND BOUNDARY



**AGENCY REVIEW  
NOT FOR CONSTRUCTION**

**Part of Seattle SEA-TAC INTERNATIONAL AIRPORT ALBUURN WETLAND MITIGATION**

**PROJECT: ALBUURN WETLAND MITIGATION**

**SHEET NO. SOIL AND HABITAT FEATURES PLAN**

DATE: 11/27/01 FILENAME: 29121401.DWG PLOT: 29121401 29121401

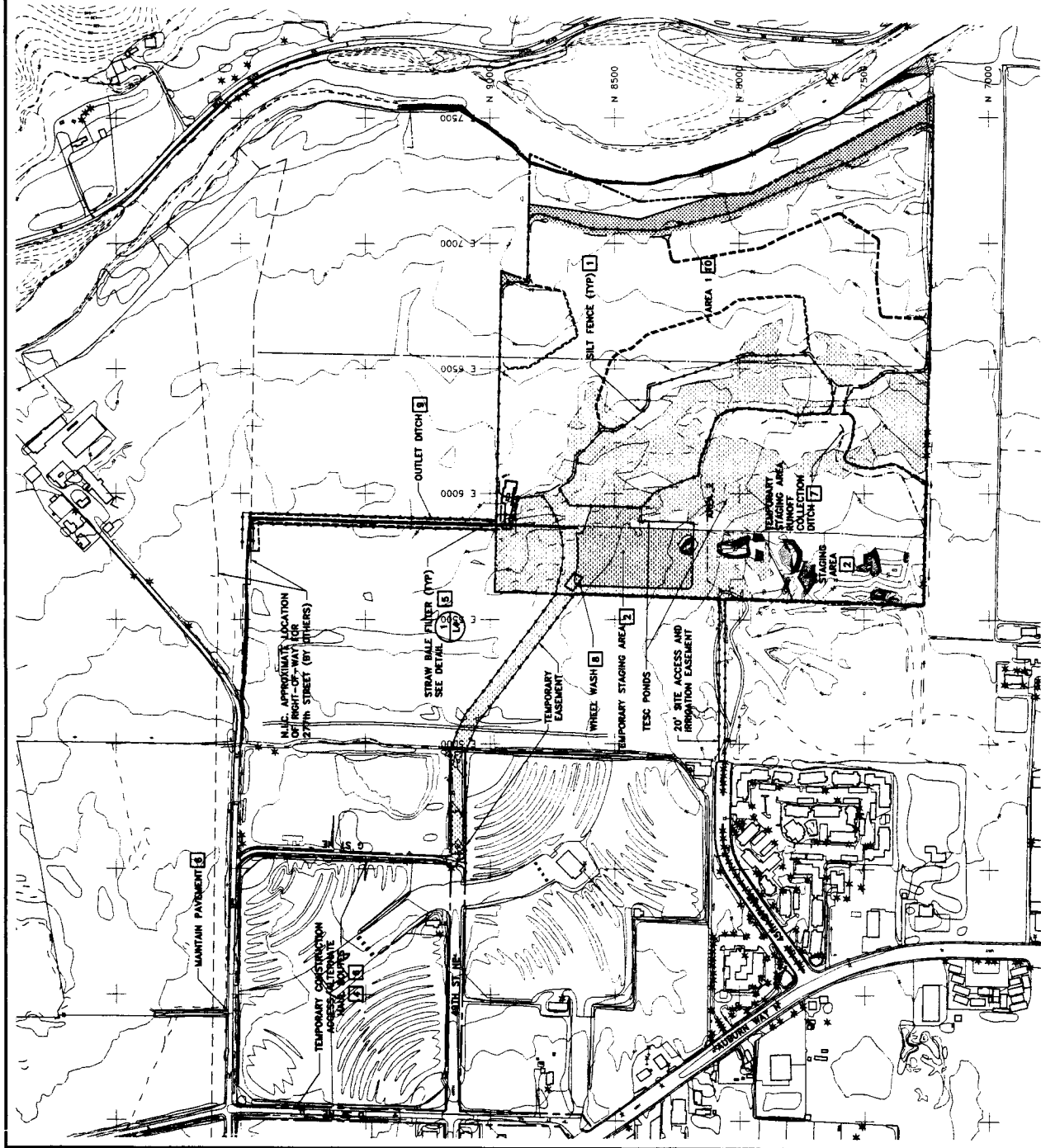
CALL US TODAY 1-800-424-5555

**Parametrix, Inc.**  
5908 Lk. Washington Blvd. NE  
Kirkland, WA 98033  
Ph: (425) 822-8800

Quality Services Through Employee Ownership

29121401

APPENDIX E



**TEMPORARY EROSION AND SEDIMENT CONTROL REQUIREMENTS:**

1. PRIOR TO CONSTRUCTION ACTIVITIES, INSTALL SILT FENCE AROUND PROJECT LIMITS INCLUDING TEMPORARY ACCESS ROADS, STAGING AREA, AND GRADING LIMITS AS SHOWN. LOCATION OF SILT FENCE SHALL BE AS SHOWN ON CROSS SECTIONS ON SHEET C8 OR AS DIRECTED BY THE ENGINEER.
2. WITHIN THE STAGING AREA, PROVIDE ADDITIONAL SILT FENCE, TEMPORARY DITCHING, STRAW BALES, HYDROSEED, MULCH, AND PLASTIC SHEETING, AS NEEDED TO PROTECT TEMPORARY MATERIAL PILES AND CONTROL EROSION AND RUNOFF FROM STAGING OPERATIONS.
3. INSTALL HYDROMULCH SEEDING AND EROSION CONTROL MATTING AS SPECIFIED AND CONSISTENT WITH THE CITY OF AUBURN GRADING PERMIT.
4. UNPAVED TEMPORARY CONSTRUCTION ACCESS ROAD SURFACES SHALL BE KEPT CLEAN, WATERED AND MAINTAINED AT ALL TIMES TO CONTROL FLIGHTS OF DIRT AND TO PREVENT DIRT AND MUD FROM BEING TRACKED OFF SITE. APPLY WATER AS NEEDED TO CONTROL DUST DURING ALL ON-SITE EXCAVATION, HAUL, STOCKPILE, COMPACTION, AND OTHER APPLICABLE CONSTRUCTION OPERATIONS. STRAW BALE FILTERS TO BE FIELD LOCATED BY ENGINEER.
5. MAINTAIN PAVEMENT IN GOOD REPAIR. CLEAN WITH VACUUM EQUIPMENT DAILY AND AS NEEDED TO PREVENT TRACKING OF DIRT AND MUD OFF SITE.
6. CONSTRUCT AND MAINTAIN A TEMPORARY RUNOFF COLLECTION DITCH DURING ALL CONSTRUCTION STAGING OPERATIONS. DITCH SHALL COMPLETELY ENCOMPASS STAGING AREA AND BE GRADED TO DRAIN TO TESCs.
7. PROVIDE WHEEL WASH AT SITE ENTRANCE. ROUTE ALL OUTBOUND TRAFFIC THROUGH WHEEL WASH.
8. LINE OUTLET DITCH WITH GEOTEXTILE FABRIC AS NEEDED TO PREVENT EROSION OR TURBIDITY FROM CONTRACTOR'S DEWATERING DISCHARGE.
9. TESCs FOR AREA 1 ARE TO BE LOCATED IN THE EXCAVATION AREA. WATER COLLECTED BY THESE PONDS WILL BE ROUTED TO AN ON-SITE WATER TREATMENT FACILITY.
11. MAJOR CONSTRUCTION ACTIVITIES WILL NOT OCCUR BETWEEN OCTOBER 31 AND MARCH 31 TO AVOID IMPACTS TO OVER WINTERING BALD EAGLES.

**LEGEND**

- PROPERTY BOUNDARY
- SILT FENCE
- EXISTING WETLANDS WITHIN PROPERTY BOUNDARY
- GRAVEL PATH



200 0 200 400  
SCALE  
FEET

**AGENCY REVIEW  
NOT FOR CONSTRUCTION**

Part of Seattle  
**SEA-TAC INTERNATIONAL AIRPORT**  
PROJECT: AUBURN WETLAND MITIGATION  
SHEET NO. **TESC PLAN**

281214C9  
DATE OF REVISION: 11/20/2018  
STA-8804-TE1  
APPENDIX E

| NO. | REVISIONS | DATE | BY | CHECKED BY |
|-----|-----------|------|----|------------|
|     |           |      |    |            |
|     |           |      |    |            |
|     |           |      |    |            |
|     |           |      |    |            |
|     |           |      |    |            |
|     |           |      |    |            |
|     |           |      |    |            |
|     |           |      |    |            |
|     |           |      |    |            |

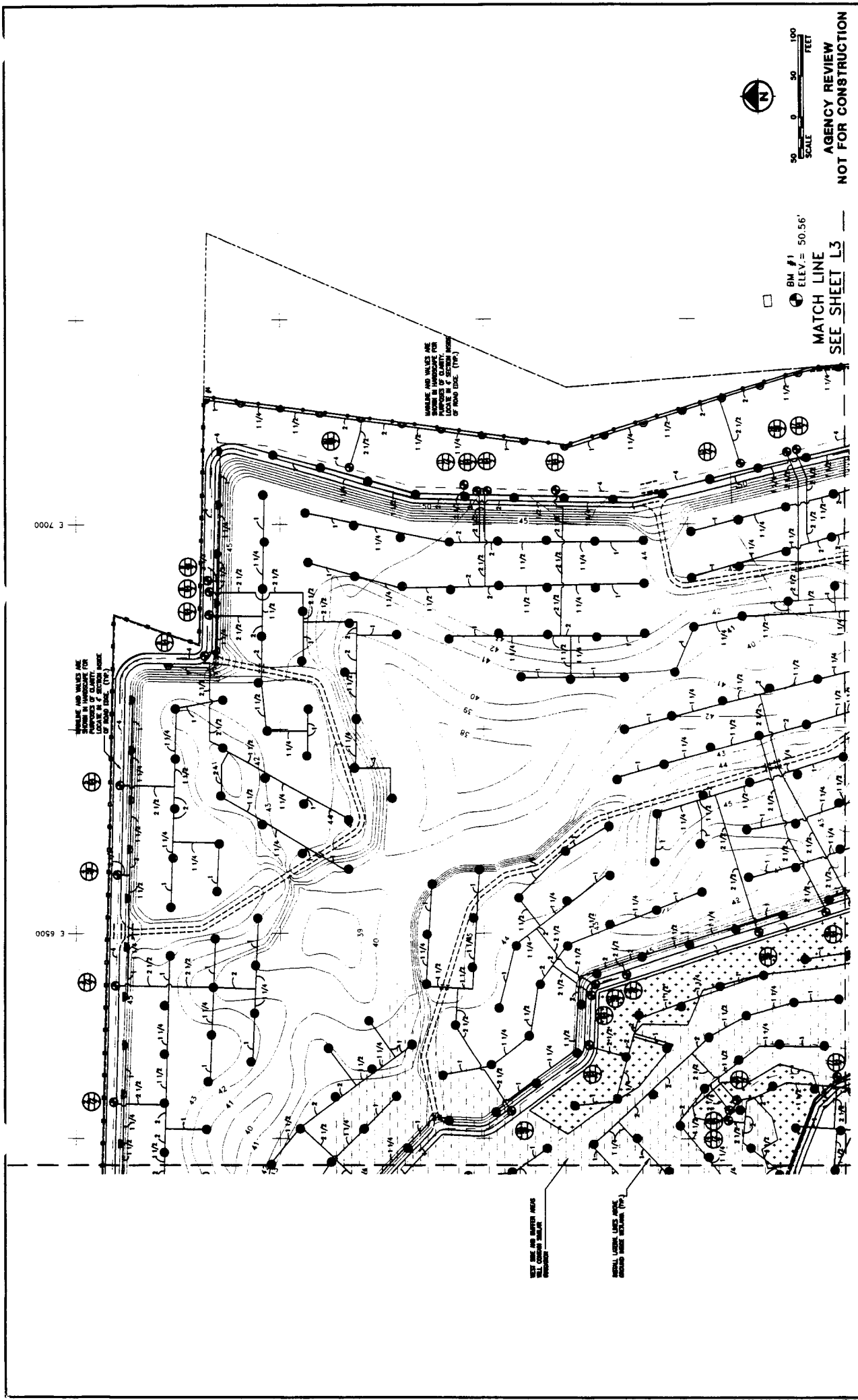
**Parametrix, Inc.**  
5800 Lt. Washington Blvd. NE  
Kirkland, WA 98033  
Ph: (425) 822-8880  
Quality Service Through Employee Ownership

281214C9

281214B6

CALL 48 HOURS BEFORE YOU DIG 1-800-424-5880





**CALL 48 HOURS BEFORE YOU DIG**  
1-800-424-5555

**PARAMETRIX, INC.**  
2812148A

**AGENCY REVIEW NOT FOR CONSTRUCTION**

**MATCH LINE SEE SHEET L3**

BIM #1  
ELEV. = 50.56'

**Part of Seattle SEA-TAC International Airport Auburn Wetland Mitigation Phase I Irrigation Plan NE**

2812142  
STA. - 8804-L3  
APPENDIX E

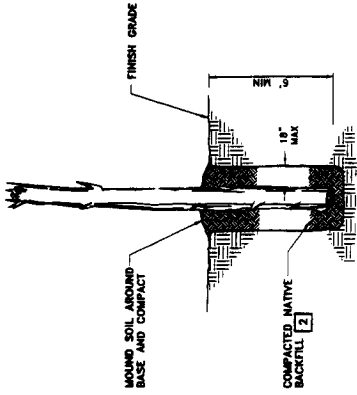
| NO. | DATE | DESCRIPTION | BY | CHKD |
|-----|------|-------------|----|------|
|     |      |             |    |      |
|     |      |             |    |      |
|     |      |             |    |      |
|     |      |             |    |      |
|     |      |             |    |      |
|     |      |             |    |      |
|     |      |             |    |      |
|     |      |             |    |      |
|     |      |             |    |      |
|     |      |             |    |      |

2812148E

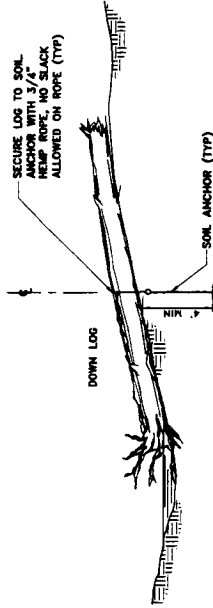


**NOTES:**

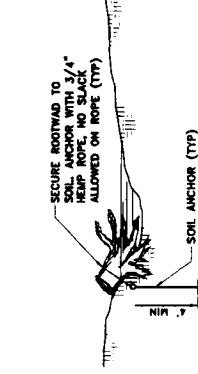
1. LOCATION OF ALL STANDING SNAGS, HABITAT LOGS, AND ROOT WADS SHALL BE STAKED BY THE ENGINEER.
2. BACKFILL IN 12" LIFTS AND ROD TO COMPACT AROUND LOG.
3. LOGS WILL RANGE FROM APPROXIMATELY 8' TO 40' IN LENGTH. THE WIDTH WILL RANGE FROM APPROXIMATELY 8" TO 36".



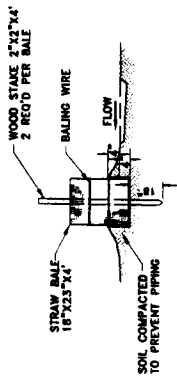
**DETAIL 3**  
NO SCALE  
TYPICAL SNAG



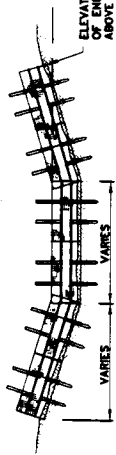
**DETAIL 4**  
NO SCALE  
TYPICAL HABITAT LOGS



**DETAIL 5**  
NO SCALE  
TYPICAL MUD



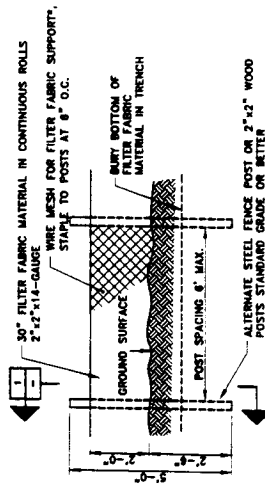
**SECTION**



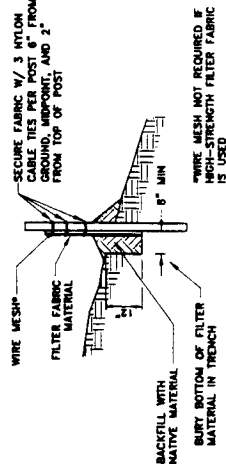
**ELEVATION**

**1**  
TE1

**DETAIL 1**  
NO SCALE  
STRAW BALE FILTER



**DETAIL 2**  
NO SCALE  
N.I.S.



**SECTION**  
N.I.S.

DATE: 10/10/01 PROJECT: 281214LA

AGENCY REVIEW  
NOT FOR CONSTRUCTION

Parametrix, Inc.  
5008 Lt. Washington Blvd. NE  
Redmond, WA 98053  
Ph: (425) 822-8800  
Fax: (425) 822-8801  
Quality Service Through Employee Ownership

Redmond  
SEA-TAC INTERNATIONAL AIRPORT  
AUBURN WETLAND MITIGATION

MISCELLANEOUS CONSTRUCTION  
DETAILS

| NO. | REV. | DATE | DESCRIPTION |
|-----|------|------|-------------|
| 1   |      |      |             |
| 2   |      |      |             |
| 3   |      |      |             |
| 4   |      |      |             |
| 5   |      |      |             |
| 6   |      |      |             |
| 7   |      |      |             |
| 8   |      |      |             |
| 9   |      |      |             |
| 10  |      |      |             |
| 11  |      |      |             |
| 12  |      |      |             |
| 13  |      |      |             |
| 14  |      |      |             |
| 15  |      |      |             |
| 16  |      |      |             |
| 17  |      |      |             |
| 18  |      |      |             |
| 19  |      |      |             |
| 20  |      |      |             |

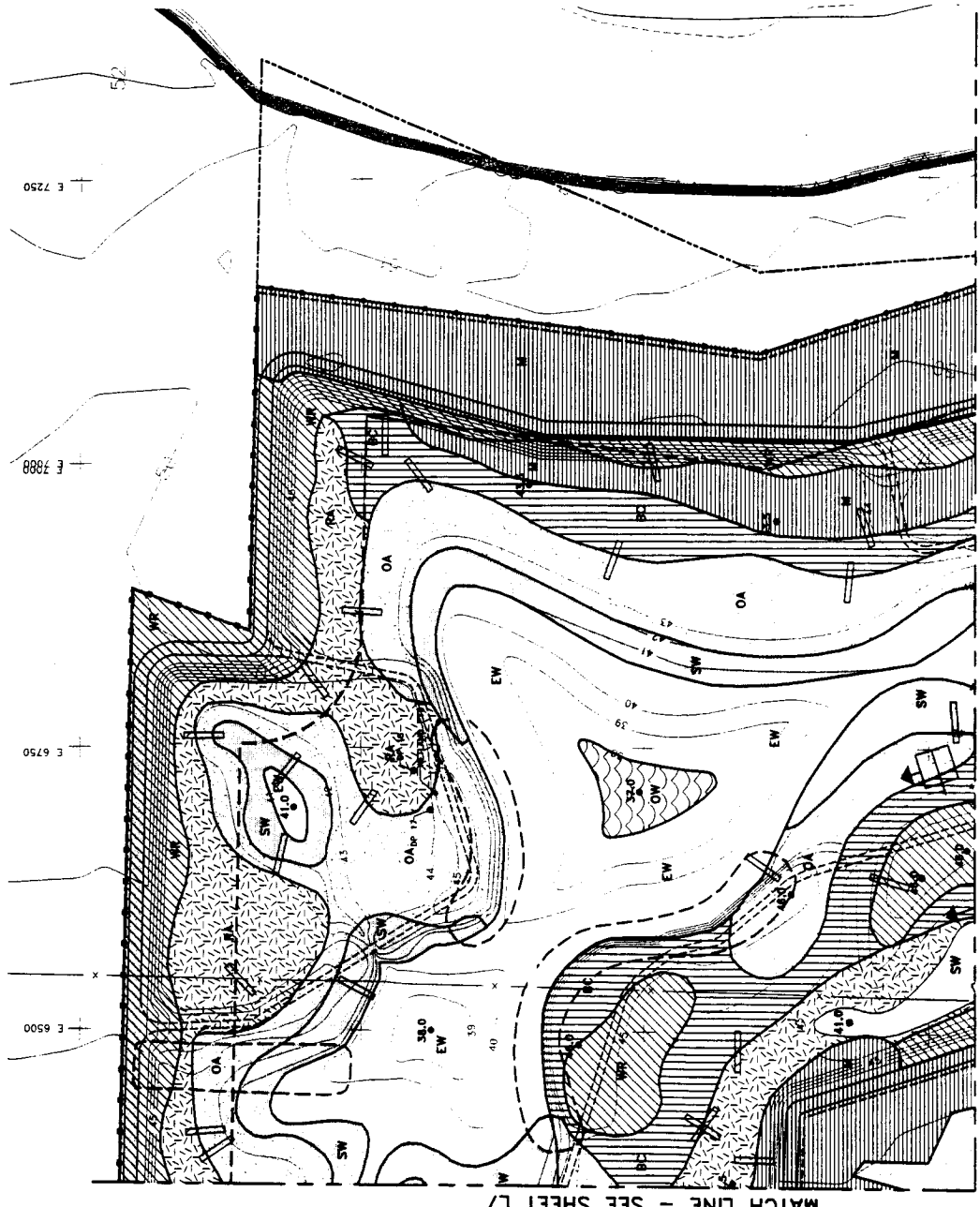
DATE: 10/10/01 PROJECT: 281214LA

NO. 100052

DATE: 281214LA

STATION: 281214LA

APPENDIX E

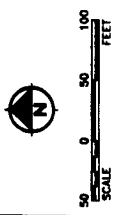


**NOTES:**

1. PROPOSED CONTOURS AS SHOWN INDICATE FINISH GRADE. FINISH GRADE INCLUDES 1" WETLAND SOIL. SEE DETAIL 127.
2. FINISH AND SURFACE GRADES SHALL CONFORM TO THE FINISH GRADES AND SURFACE GRADES AS SHOWN. MEET GRADING TOLERANCE PER SPECIFICATIONS.
3. EROSION CONTROL MATING SHALL BE PLACED ON SLOPES OR STEEPER SLOPES WITHIN THE GRADING LIMITS.
4. MAINTENANCE ROADS WILL BE PLACED BY THE CONTRACTOR. THE CONTRACTOR SHALL DETERMINE THE LOCATION AND ECLOGY DETERMINE IT IS DESIRABLE TO LEAVE ALL OR PORTIONS OF THEM IN PLACE.

**LEGEND:**

- BLACK COTTONWOOD/WILLOW
- RED ALDER/SALMONBERRY
- OREGON ASH/SLOUGH SEDGE
- MIXED FOREST
- WESTERN REDCEDAR
- SHRUB WETLAND
- EMERGENT WETLAND
- OPEN WATER/NON-VEGETATED
- WETLAND CROSSING
- PLANT PATTERN LAYOUT REFERENCE AREA (SEE SPECIFICATIONS)
- LOG
- GRADING LIMITS
- GRAVEL PATH
- MAINTENANCE ROAD
- PROPERTY BOUNDARIES
- 100' BUFFER



MATCH LINE - SEE SHEET L6

MATCH LINE - SEE SHEET L7

**AGENCY REVIEW  
NOT FOR CONSTRUCTION**

|                                                                                          |                                                                                                    |                                |                          |          |                           |
|------------------------------------------------------------------------------------------|----------------------------------------------------------------------------------------------------|--------------------------------|--------------------------|----------|---------------------------|
| <b>CALL 48 HOURS BEFORE YOU DIG</b><br>1-800-424-3355                                    | <b>Parametrix, Inc.</b><br>5608 Lt. Washington Blvd. NE<br>Redmond, WA 98033<br>Ph: (425) 622-6880 | DESIGNER<br>CHECKED BY<br>DATE | REVISIONS<br>NO. DATE BY | 281214L6 | STA-8804-L5<br>APPENDIX E |
|                                                                                          |                                                                                                    |                                |                          |          |                           |
| Part of Seattle SEA-TAC INTERNATIONAL AIRPORT AUBURN WETLAND MITIGATION PLANTING PLAN NE |                                                                                                    | DRAWN BY<br>CHECKED BY<br>DATE | NO. DATE BY              | 281214L5 | STA-8804-L5<br>APPENDIX E |

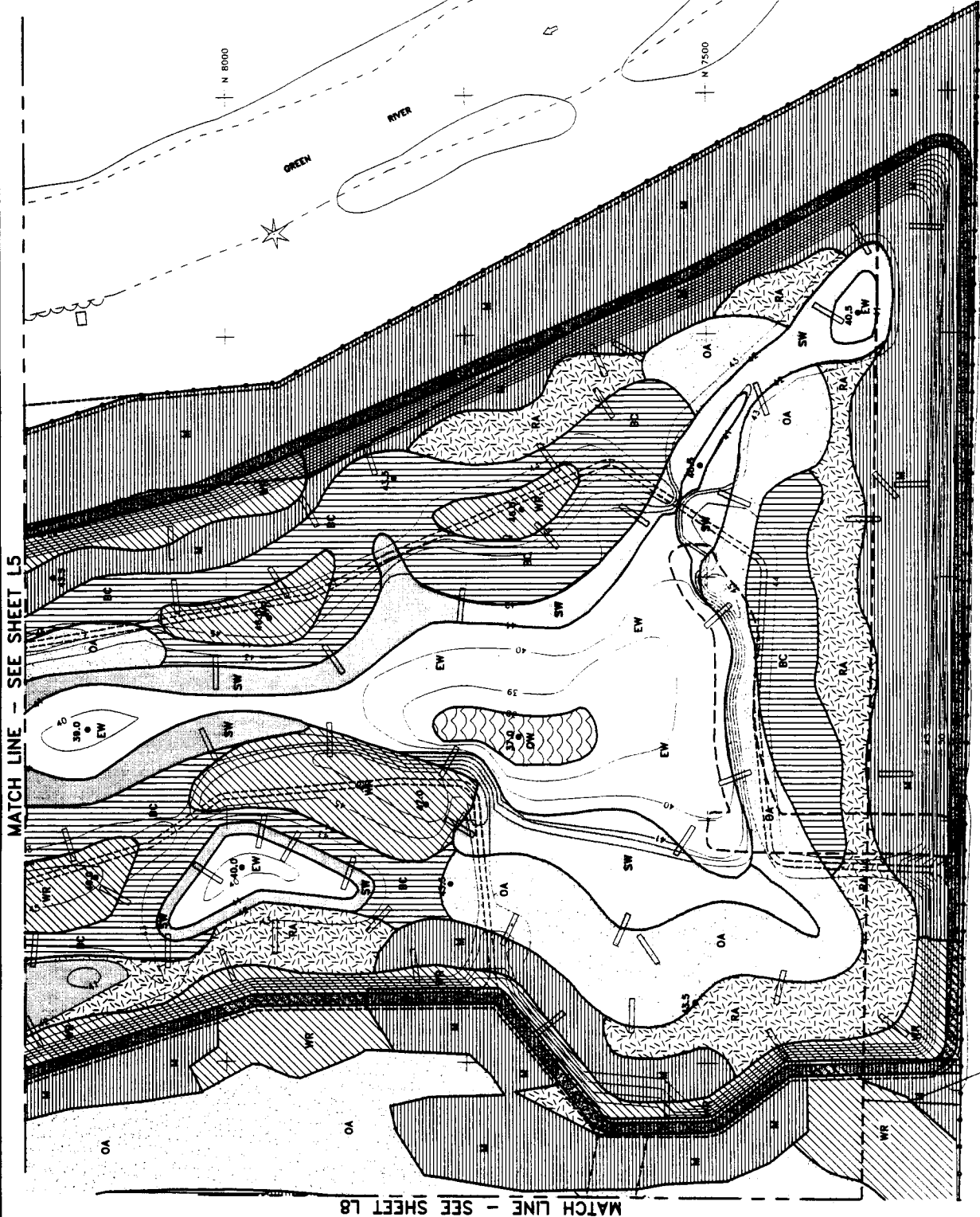
**NOTES:**

1. PROPOSED CONTOURS AS SHOWN INDICATE FINISH GRADE. FINISH GRADE INCLUDES 12" WETLAND SOIL. SEE DETAIL (12)
2. FINISH AND SURGRADE GRADES SHALL CONFORM TO THE GENERAL SHAPES AND ELEVATIONS AS SHOWN. MEET GRADING TOLERANCE PER SPECIFICATIONS.
3. EROSION CONTROL MATINGS SHALL BE PLACED ON ALL 3:1 OR STEEPER SLOPES WITHIN THE GRADING LIMITS.



**LEGEND:**

- BLACK COTTONWOOD/WILLOW
- RED ALDER/SALMONBERRY
- OREGON ASH/SLOUGH SEDGE
- MIXED FOREST
- WESTERN REDCEDAR
- SHRUB WETLAND
- EMERGENT WETLAND
- OPEN WATER/NON-VEGETATED
- WETLAND CROSSING
- PLANT PATTERNS LAYOUT REFERENCE AREA (SEE SPECIFICATIONS)
- LOG
- GRADING LIMITS
- GRAVEL PATH
- MAINTENANCE ROAD
- PROPERTY BOUNDARIES
- 100' BUFFER
- FENCE



AGENCY REVIEW  
NOT FOR CONSTRUCTION

**Parametrix, Inc.**  
 5000 L.I. Washington Blvd. NE  
 Redmond, WA 98053  
 Ph: (425) 822-8880

**SEA-TAC INTERNATIONAL AIRPORT  
 AIRBURN WETLAND MITIGATION  
 PLANTING PLAN SE**

PROJECT NO: 100032  
 DATE: 28/12/16  
 SHEET NO: ST1A-9804-L6

| NO. | DATE | DESCRIPTION |
|-----|------|-------------|
|     |      |             |
|     |      |             |
|     |      |             |
|     |      |             |
|     |      |             |
|     |      |             |
|     |      |             |
|     |      |             |
|     |      |             |
|     |      |             |
|     |      |             |

| NO. | DATE | DESCRIPTION |
|-----|------|-------------|
|     |      |             |
|     |      |             |
|     |      |             |
|     |      |             |
|     |      |             |
|     |      |             |
|     |      |             |
|     |      |             |
|     |      |             |
|     |      |             |
|     |      |             |

**Parametrix, Inc.**  
 5000 L.I. Washington Blvd. NE  
 Redmond, WA 98053  
 Ph: (425) 822-8880

791714A

CALL 48 HOURS BEFORE YOU DIG  
 1-800-424-5555

AR 049516

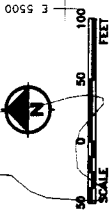
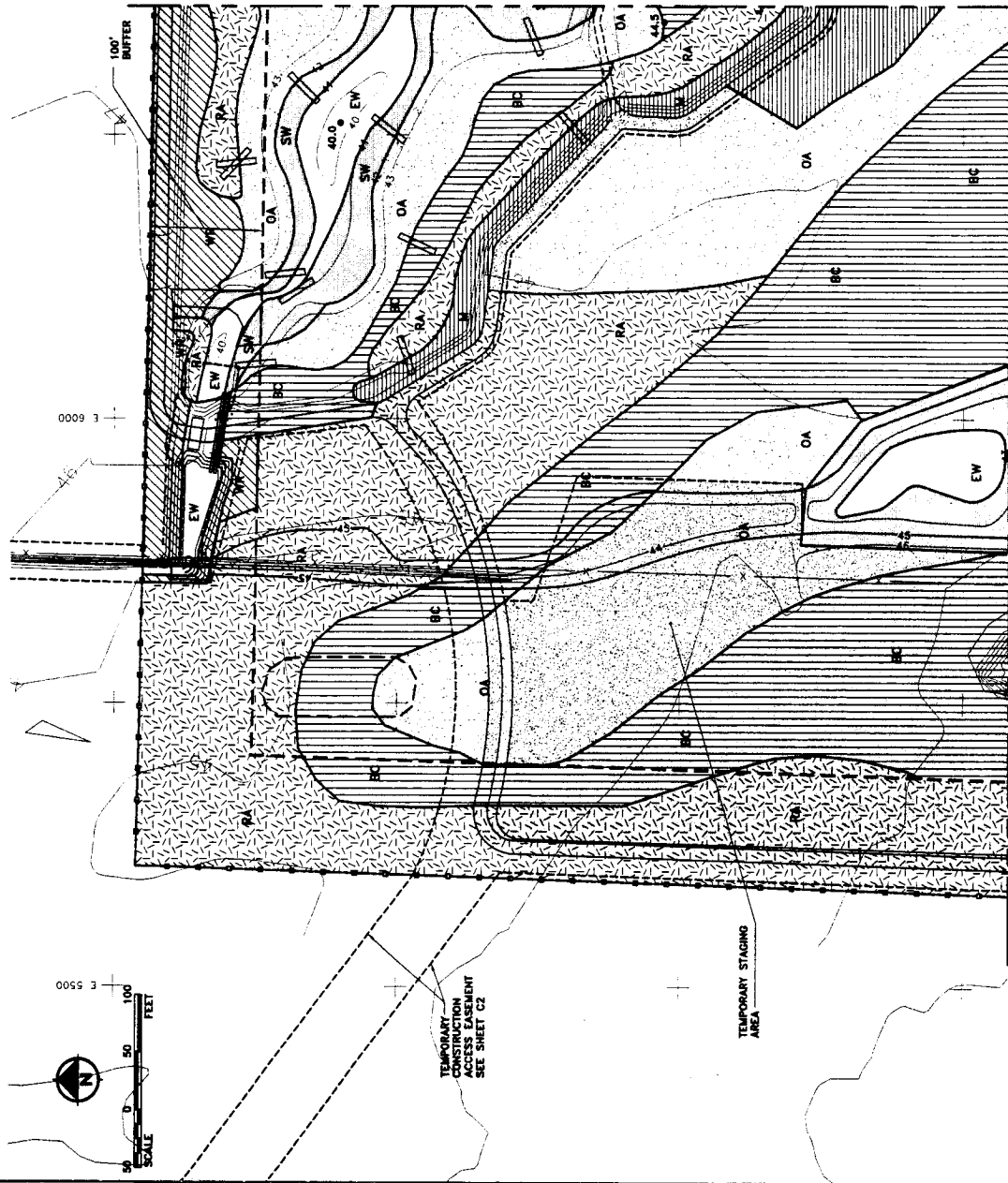


**NOTES:**

1. PROPOSED CONTOURS AS SHOWN INDICATE FINISH GRADE. FINISH GRADE INCLUDES 12" WETLAND SOIL. SEE DETAIL (1) (27)
2. FINISH AND SUBGRADE GRADES SHALL CONFORM TO THE GENERAL SHAPES AND ELEVATIONS AS SHOWN. MEET GRADING TOLERANCE PER SPECIFICATIONS.
3. EROSION CONTROL MATTING SHALL BE PLACED ON ALL 3:1 OR STEEPER SLOPES WITHIN THE GRADING LIMITS.

**LEGEND:**

|  |                                                          |
|--|----------------------------------------------------------|
|  | BLACK COTTONWOOD/WILLOW                                  |
|  | RED ALDER/SALMONBERRY                                    |
|  | OREGON ASH/SLOUGH SEDGE                                  |
|  | MIKED FOREST                                             |
|  | WESTERN REDCEDAR                                         |
|  | SHRUB WETLAND                                            |
|  | EMERGENT WETLAND                                         |
|  | OPEN WATER/NON-VEGETATED                                 |
|  | WETLAND CROSSING                                         |
|  | PLANT PATTERN LAYOUT REFERENCE AREA (SEE SPECIFICATIONS) |
|  | LOG                                                      |
|  | GRADING LIMITS                                           |
|  | GRAVEL PATH                                              |
|  | MAINTENANCE ROAD                                         |
|  | PROPERTY BOUNDARIES                                      |
|  | 100' BUFFER                                              |



TEMPORARY ACCESS EASEMENT  
SEE SHEET C2

TEMPORARY STAGING  
AREA

MATCH LINE - SEE SHEET L5

MATCH LINE - SEE SHEET L8

AGENCY REVIEW  
NOT FOR CONSTRUCTION

|                                                        |  |                                                                                                                                                      |  |                                                                                             |  |                                                                                                             |  |                                           |  |                                                                                          |  |                                            |  |
|--------------------------------------------------------|--|------------------------------------------------------------------------------------------------------------------------------------------------------|--|---------------------------------------------------------------------------------------------|--|-------------------------------------------------------------------------------------------------------------|--|-------------------------------------------|--|------------------------------------------------------------------------------------------|--|--------------------------------------------|--|
| <p>CALL 48 HOURS BEFORE YOU DIG<br/>1-800-424-3886</p> |  | <p>Parametrix, Inc.<br/>5808 Lt. Washington Blvd. NE<br/>Redmond, WA 98033<br/>PH: (425) 822-8880<br/>Quality Service Through Employee Ownership</p> |  | <p>PROJECT NO: 28121.41A<br/>SHEET NO: 28121.41A<br/>DATE: 11/17/07<br/>SCALE: AS SHOWN</p> |  | <p>PORT OF SEASIDE<br/>SEA-TAC INTERNATIONAL AIRPORT<br/>AUBURN WETLAND MITIGATION<br/>PLANTING PLAN NW</p> |  | <p>DATE: 11/17/07<br/>SCALE: AS SHOWN</p> |  | <p>PROJECT NO: 100052<br/>SHEET NO: 28121.41A<br/>DATE: 11/17/07<br/>SCALE: AS SHOWN</p> |  | <p>STATION: STA-9804-L7<br/>APPENDIX E</p> |  |
|--------------------------------------------------------|--|------------------------------------------------------------------------------------------------------------------------------------------------------|--|---------------------------------------------------------------------------------------------|--|-------------------------------------------------------------------------------------------------------------|--|-------------------------------------------|--|------------------------------------------------------------------------------------------|--|--------------------------------------------|--|

AR 049517

MATCH LINE - SEE SHEET L7

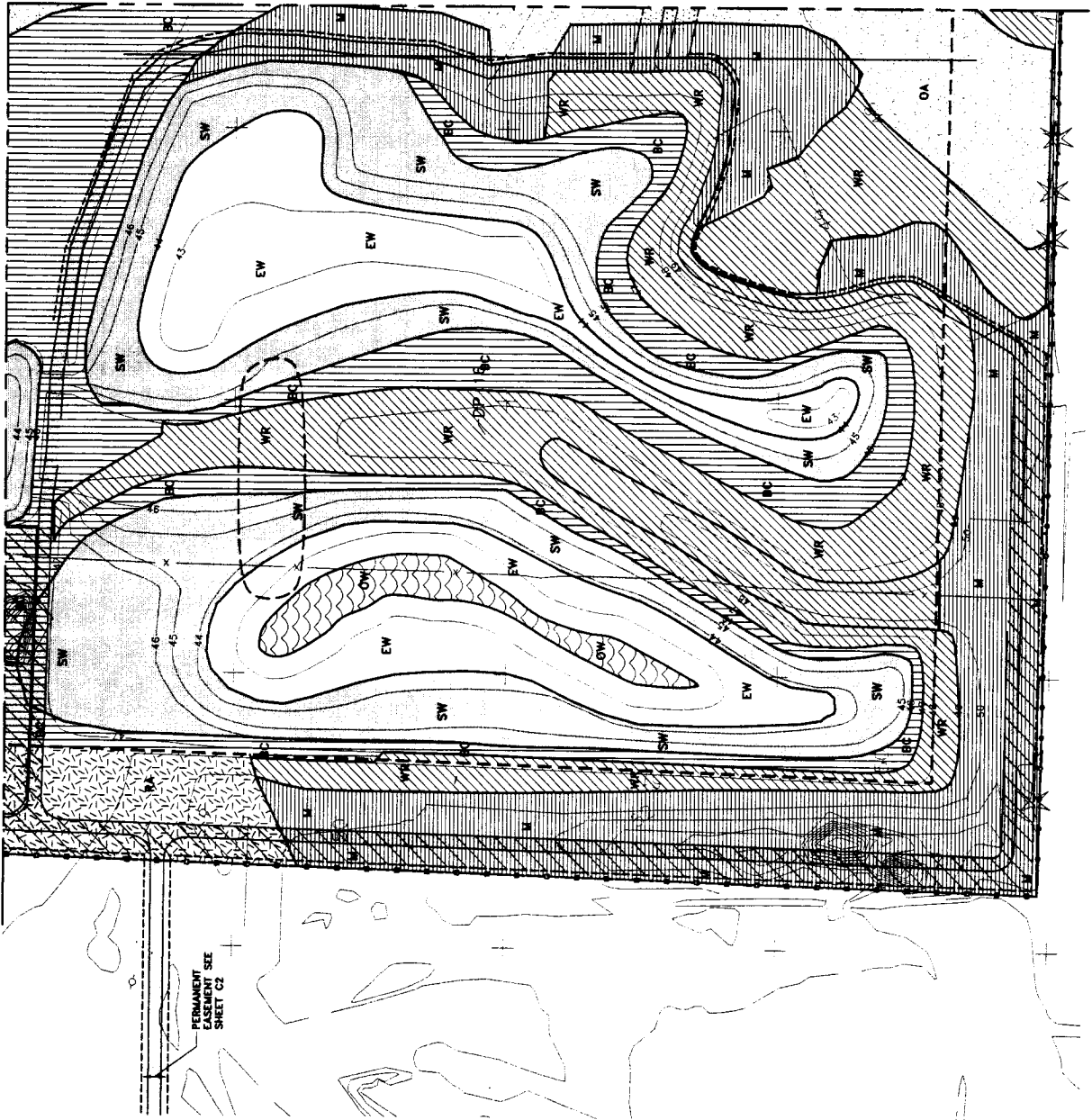
NOTES:

1. PROPOSED CONTOURS AS SHOWN INDICATE FINISH GRADE. FINISH GRADE INCLUDES 12" WETLAND SOIL. SEE DETAIL (1/27)
2. FINISH AND SUBGRADE GRADES SHALL CONFORM TO THE GENERAL SHAPES AND ELEVATIONS AS SHOWN. MEET GRADING TOLERANCE PER SPECIFICATIONS.
3. EROSION CONTROL MATTING SHALL BE PLACED ON ALL 3:1 OR STEEPER SLOPES WITHIN THE GRADING LIMITS.
4. PHASE 2 GRADING LIMITS TO BE FIELD STAKED BY THE ENGINEER.

LEGEND:

- BC BLACK COTTONWOOD/WILLOW
- RA RED ALDER/SALMONBERRY
- OA OREGON ASH/SLOUGH SEDGE
- M MIIKED FOREST
- WR WESTERN REDCEDAR
- SW SHRUB WETLAND
- EW EMERGENT WETLAND
- OW OPEN WATER/NON-VEGETATED
- WETLAND CROSSING
- PLANT PATTERN LAYOUT REFERENCE AREA (SEE SPECIFICATIONS)
- LOG
- GRADING LIMITS
- GRAVEL PATH
- MAINTENANCE ROAD
- PROPERTY BOUNDARIES
- 100' BUFFER

MATCH LINE - SEE SHEET L6



PERMANENT EASEMENT SEE SHEET C2



SCALE  
0 50 100  
FEET

CALL US HOURS BEFORE YOU DIG  
1-800-424-5555

**Parametrix, Inc.**  
5908 1st Washington Blvd. NE  
Kirkland, WA 98033  
Ph: (425) 822-8880

DATE: 11/27/01  
PROJECT: 281214A

DATE: 11/27/01  
PROJECT: 281214A

QUALITY SERVICE THROUGH EMPLOYEE OWNERSHIP

| NO. | DATE | REVISIONS |
|-----|------|-----------|
|     |      |           |
|     |      |           |
|     |      |           |
|     |      |           |

| NO. | DATE | REVISIONS |
|-----|------|-----------|
|     |      |           |
|     |      |           |
|     |      |           |
|     |      |           |

Port of Seattle  
SEA-TAC INTERNATIONAL AIRPORT  
PROJECT: AUBURN WETLAND MITIGATION  
SHEET NO. PLANTING PLAN SW

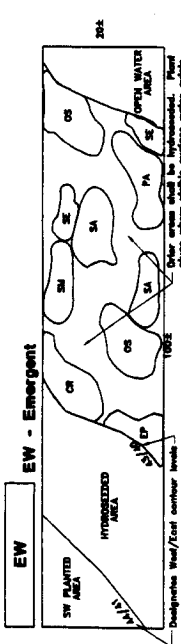
AGENCY REVIEW  
NOT FOR CONSTRUCTION

281214A

281214A

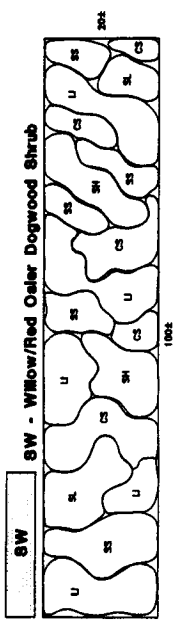
APPENDIX E

AR 049518

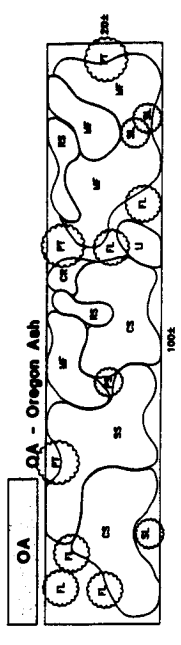


| Scientific Name                  | Common Name    | Planting Zone | Typical Spacing |
|----------------------------------|----------------|---------------|-----------------|
| Hercs                            |                |               |                 |
| OS - <i>Oenanthe laticarpa</i>   | Isolated water | 10,000        | 15' O.C.        |
| SA - <i>Sagittaria arifolia</i>  | water plants   |               | 15' O.C.        |
| SE - <i>Sagittaria arifolia</i>  | water plants   |               | 15' O.C.        |
| PA - <i>Phragmites australis</i> | water plants   |               | 15' O.C.        |
| SA - <i>Sagittaria arifolia</i>  | water plants   |               | 15' O.C.        |
| SE - <i>Sagittaria arifolia</i>  | water plants   |               | 15' O.C.        |
| PA - <i>Phragmites australis</i> | water plants   |               | 15' O.C.        |

**NOTE:**  
The perimeter of emergent wetlands will be hydro-wetted with refuge used soil (See Table 7.2-2 in MAP report). Flooded areas will be planted with plug or containerized material listed above.

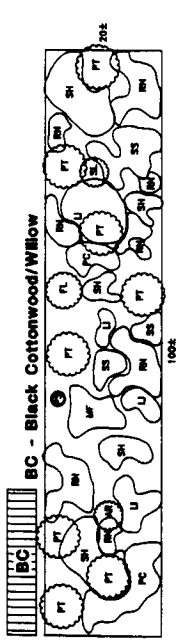


| Scientific Name                 | Common Name        | Planting Zone | Typical Spacing |
|---------------------------------|--------------------|---------------|-----------------|
| Shrubs                          |                    |               |                 |
| U - <i>Lindera involucrata</i>  | Inhberry           | Area Total    | 4 ft            |
| SL - <i>Sida acuta</i>          | red-oyster dogwood | 2,100         | 6 ft            |
| CS - <i>Cornus alternifolia</i> | hackberry          | 1,500         | 6 ft            |
| SH - <i>Salix humilis</i>       | willow             | 1,500         | 6 ft            |
| SS - <i>Salix alba</i>          | willow             | 1,500         | 6 ft            |



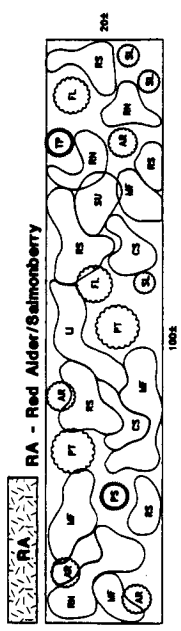
| Scientific Name                 | Common Name | Planting Zone | Typical Spacing |
|---------------------------------|-------------|---------------|-----------------|
| Tree                            |             |               |                 |
| FL - <i>Fraxinus latifolia</i>  | Oregon ash  | Area Total    | 20 ft           |
| CS - <i>Cornus alternifolia</i> | hackberry   | 1,500         | 6 ft            |
| SS - <i>Salix alba</i>          | willow      | 1,500         | 6 ft            |
| U - <i>Lindera involucrata</i>  | Inhberry    | 1,500         | 6 ft            |
| PT - <i>Populus tremula</i>     | poplar      | 1,500         | 6 ft            |

**NOTE:**  
Planting zones shall be established in second phase after year 3 monitoring. These plants shall be planted by the wetland biologist in locations where partial shade and favorable soil conditions are present.



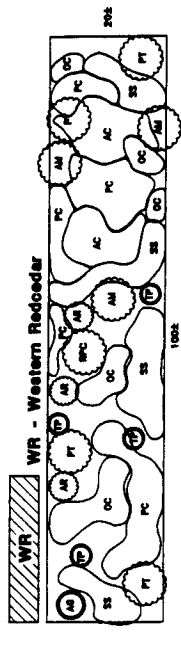
| Scientific Name                 | Common Name      | Planting Zone | Typical Spacing |
|---------------------------------|------------------|---------------|-----------------|
| Tree                            |                  |               |                 |
| PT - <i>Populus trichocarpa</i> | Black cottonwood | Area Total    | 4 ft            |
| SH - <i>Salix humilis</i>       | willow           | 1,500         | 6 ft            |
| U - <i>Lindera involucrata</i>  | Inhberry         | 1,500         | 6 ft            |
| SS - <i>Salix alba</i>          | willow           | 1,500         | 6 ft            |
| PT - <i>Populus tremula</i>     | poplar           | 1,500         | 6 ft            |

**NOTE:**  
Planting zones will be hydro-wetted with either wet conditions, or long-term used soil (See Table 7.2-2 in MAP report). Sites areas shall be planted in a second phase after year 3 monitoring. These plants shall be planted by the wetland biologist in locations where partial shade and favorable soil conditions are present.



| Scientific Name                 | Common Name | Planting Zone | Typical Spacing |
|---------------------------------|-------------|---------------|-----------------|
| Tree                            |             |               |                 |
| RA - <i>Alnus rubra</i>         | Red alder   | Area Total    | 4 ft            |
| PT - <i>Populus tremula</i>     | poplar      | 1,500         | 6 ft            |
| CS - <i>Cornus alternifolia</i> | hackberry   | 1,500         | 6 ft            |
| SS - <i>Salix alba</i>          | willow      | 1,500         | 6 ft            |

**NOTE:**  
Planting zones will be hydro-wetted with either wet conditions, or long-term used soil (See Table 7.2-2 in MAP report). Sites areas shall be planted in a second phase after year 3 monitoring. These plants shall be planted by the wetland biologist in locations where partial shade and favorable soil conditions are present.



| Scientific Name                 | Common Name      | Planting Zone | Typical Spacing |
|---------------------------------|------------------|---------------|-----------------|
| Tree                            |                  |               |                 |
| WR - <i>Thuja occidentalis</i>  | Western redcedar | Area Total    | 4 ft            |
| PT - <i>Populus tremula</i>     | poplar           | 1,500         | 6 ft            |
| CS - <i>Cornus alternifolia</i> | hackberry        | 1,500         | 6 ft            |
| SS - <i>Salix alba</i>          | willow           | 1,500         | 6 ft            |

**NOTE:**  
Planting zones will be hydro-wetted with either wet conditions, or long-term used soil (See Table 7.2-2 in MAP report). Sites areas shall be planted in a second phase after year 3 monitoring. These plants shall be planted by the wetland biologist in locations where partial shade and favorable soil conditions are present.

**CALL 48 HOURS BEFORE FOR BIDDING**  
1-800-424-5555

**Paramatrix, Inc.**  
5008 Lt. Washington Blvd. NE  
Redmond, WA 98033  
Ph: (425) 822-8800

Quality Service Through Employee Ownership

**REVISED:**

| NO. | DATE | BY | DESCRIPTION |
|-----|------|----|-------------|
|     |      |    |             |
|     |      |    |             |
|     |      |    |             |
|     |      |    |             |

**SEA-TAC**  
**Port of Seattle**  
**SEA-TAC INTERNATIONAL AIRPORT**  
**AUBURN WETLAND MITIGATION**

**NOT FOR CONSTRUCTION**

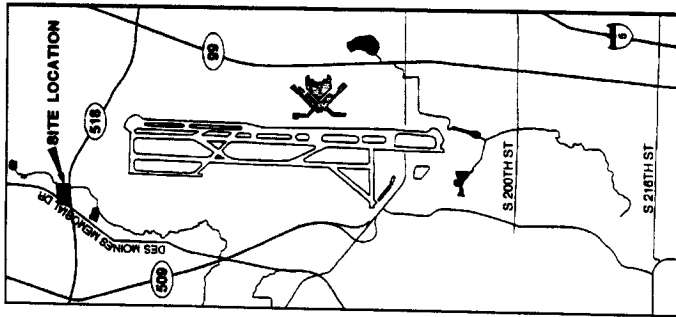
**PLANTING SCHEDULE**

100052  
2812149  
STA-9804-L3





**VICINITY MAP**



**LEGEND**

- CULVERT
- SPOT ELEVATION
- KEY NOTE NUMBER REFERENCE
- SURFACE WATER DITCH
- EXISTING CONTOUR
- PROPOSED CONTOUR
- EXISTING GRADE (SECTION)
- SPAWNING GRAVEL (SECTION)
- CRUSHED SURFACING BASE COURSE (SECTION)
- QUARRY SPALLS
- CONCRETE
- EMBANKMENT
- NATIVE SUBGRADE
- GRAVEL
- PAVEMENT (PLAN)
- SLOPE INDICATOR
- CONTROL POINT
- SILT FENCE
- SILT CURTAIN
- GEOTEXTILE
- EROSION CONTROL MATTING
- STRAW BALE BARRIER
- EXISTING MONITORING WELL
- CHAIN LINK FENCE
- PRIVATE PROPERTY BOUNDARY
- POINT OF INTERSECTION
- BERM
- CHANNEL CENTERLINE AND STATION
- EXISTING SANITARY SEWER LINE
- PROPOSED SANITARY SEWER LINE
- LIMIT OF CONSTRUCTION (PROJECT)
- SURVEY CONTROL POINT
- LIMIT OF RESTRICTED AREA
- EXISTING STORM DRAIN

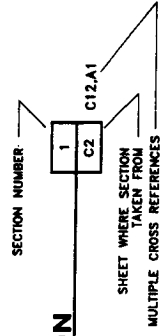
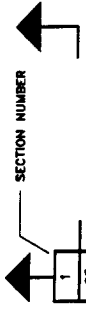
**GENERAL LEGEND**

**DRAWING TITLE:**

**PLAN**  
SUBTITLE  
SCALE

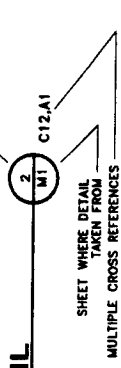


**REFERENCE SYMBOL:**



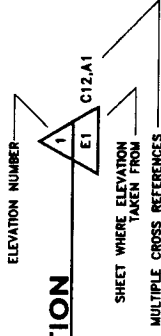
**SECTION**  
SUBTITLE  
SCALE

MULTIPLE CROSS REFERENCES



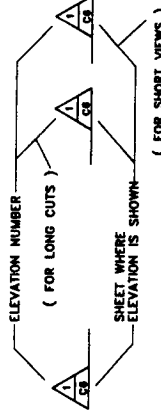
**DETAIL**  
SUBTITLE  
SCALE

MULTIPLE CROSS REFERENCES



**ELEVATION**  
SUBTITLE  
SCALE

MULTIPLE CROSS REFERENCES



( FOR LONG CUTS )

( FOR SHORT VIEWS )

**GENERAL ABBREVIATIONS**

- AND
- ASPHALT CONCRETE PAVEMENT
- APPROXIMATE
- CENTRIFUGAL
- CONCRETE METAL PIPE
- DAMAGED
- DRAINAGE
- EXISTING
- EXIST
- EL OR ELEV
- FOOT (FEET)
- GALLON
- HORIZONTAL
- HEIGHT
- INVERT ELEVATION
- INVERT
- LENGTH
- MAXIMUM
- MINIMUM
- MISCELLANEOUS
- N
- NO.
- N.T.S.
- O.C.
- PP
- R
- RADIUS
- RCP
- REINFORCED CONCRETE PIPE
- SD
- S.F.
- SS
- STA
- STATION
- TYP
- W/
- WD
- VERT/V

**SURVEY CONTROL POINTS**

- 9704-2 = REBAR WITH YELLOW CAP MARKED PAX CONTROL NEAR THE SOUTHWEST CORNER OF LORA LAKE, 11.0' SOUTHERLY OF A DOUBLE TRUNK (12" & 10") ALDER TREE WHICH IS @ THE TOP OF THE BANK & 21.0' NORTHWESTERLY FROM A SANITARY SEWER MANHOLE.
- 9704-3 = REBAR WITH YELLOW CAP MARKED PAX CONTROL NEAR THE SOUTHWEST CORNER OF LORA LAKE, 8.0' SOUTHERLY OF THE TOP OF BANK & 35.2' WEST SOUTHWEST OF A DOUBLE TRUNK (12" & 12") ALDER TREE.
- 9704-4 = REBAR WITH YELLOW CAP MARKED PAX CONTROL IN THE NORTHWESTERLY MARGIN OF THE DIRT ROAD THAT RUNS BETWEEN THE PUMPKIN PATCHES, @ THE EASTERLY END OF A BLACKBERRY PATCH, 82' +/- EASTERLY OF THE MOST NORTHWESTERLY CORNER OF A WOODEN STORAGE SHED.

NOTE: SEE C2 FOR SURVEY CONTROL POINT COORDINATES AND ELEVATIONS.

**GENERAL NOTES**

1. CALL "DIG-SAFE" (1-800-425-5555) PRIOR TO COMMENCING ANY GRADING OR EXCAVATION WORK ON THE SITE.
2. INSTALLATION OF TEMPORARY EROSION AND SEDIMENT CONTROLS SHALL BE COMPLETED PRIOR TO SITE WORK.

**AGENCY REVIEW**  
**NOT FOR CONSTRUCTION**

Port of Omaha  
BEA-TAC INTERNATIONAL AIRPORT  
DES MOINES, IOWA  
NURSERY WETLAND RESTORATION  
VICINITY MAP, SYMBOLS, NOTES  
AND ABBREVIATIONS

| NO. | DATE | DESCRIPTION |
|-----|------|-------------|
|     |      |             |
|     |      |             |
|     |      |             |

| NO. | DATE | DESCRIPTION |
|-----|------|-------------|
|     |      |             |
|     |      |             |
|     |      |             |

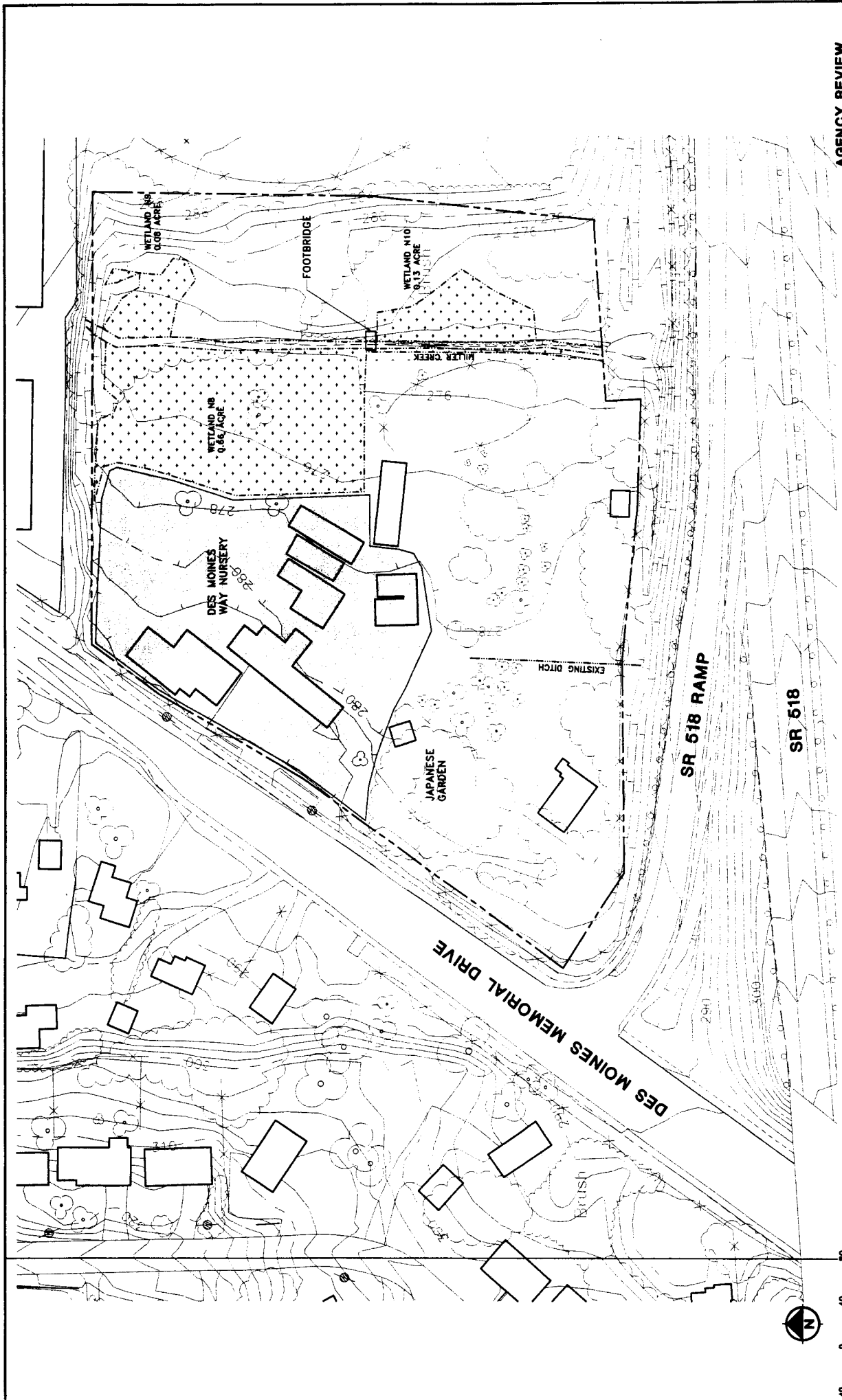
| NO. | DATE | DESCRIPTION |
|-----|------|-------------|
|     |      |             |
|     |      |             |
|     |      |             |

| NO. | DATE | DESCRIPTION |
|-----|------|-------------|
|     |      |             |
|     |      |             |
|     |      |             |

Parametrix, Inc.  
5000 Lx. Washington Blvd. NE  
Kirkland, WA 98033  
Ph: (425) 872-8880  
Quality Service Through Employee Ownership

CALL 48 HOURS BEFORE YOU DIG  
1-800-424-5555

28120SR01  
PORT OF OMAHA, IOWA  
SHEET 004  
STA-9803-C1  
APPENDIX F



**AGENCY REVIEW**  
**NOT FOR CONSTRUCTION**

**Port of Seattle**  
SEA-TAC INTERNATIONAL AIRPORT  
DES MOINES WAY  
NURSERY WETLAND RESTORATION  
EXISTING CONDITIONS

DATE: 2/12/07  
DRAWN BY: J. HAY  
CHECKED BY: J. HAY  
PROJECT NO.: 201203JC2  
SHEET NO.: STA-XXXX-C2  
APPENDIX F

REVISIONS

| NO. | DATE | BY | DESCRIPTION |
|-----|------|----|-------------|
|     |      |    |             |
|     |      |    |             |
|     |      |    |             |
|     |      |    |             |
|     |      |    |             |

SCALE

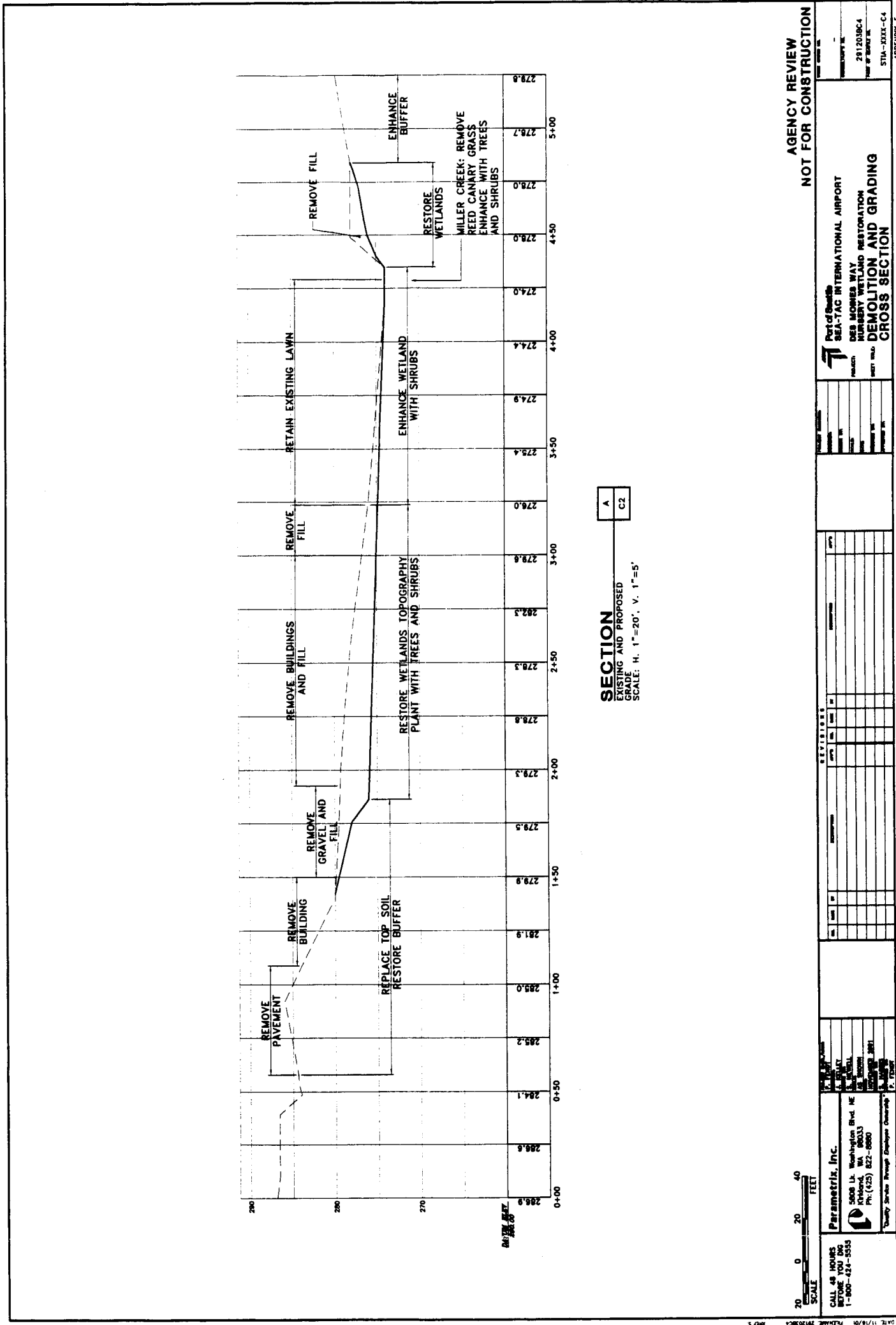
0 40 80 FEET

Parametrix, Inc.  
5909 L.L. Washington Blvd. NE  
Kirkland, WA 98033  
PH: (425) 822-8890  
Quality Service Through Employee Ownership  
P. 12207

CALL US TODAY  
OFFICE: (206) 881-1000  
1-800-424-5555

AR 049523

DATE: 11/19/06 FILENAME: 291203JC2 MAKE: 11/21/2006A POS-001 POS-002 POS-008 POS-009 POS-011



A  
C2

**SECTION**  
EXISTING AND PROPOSED  
GRADE  
SCALE: H. 1"=20', V. 1"=5'

CALL 48 HOURS BEFORE YOU DIG  
1-800-424-5553

**Parametrix, Inc.**  
5808 Lk. Washington Blvd. NE  
Kirkland, WA 98033  
Ph: (425) 822-0880

**REVISIONS**

| No. | Date | Description |
|-----|------|-------------|
|     |      |             |
|     |      |             |
|     |      |             |

**DESIGNED BY:**  
**CHECKED BY:**  
**DATE:**

**PROJECT:**  
**SHEET NO.:**

**SCALE:**

**DATE:**

**PROJECT:**

**CONTRACT NO.:**

**DATE:**

**PROJECT:**

**CONTRACT NO.:**

**DATE:**

**PROJECT:**

**CONTRACT NO.:**

**DATE:**

AGENCY REVIEW  
NOT FOR CONSTRUCTION

Port of Seattle  
SEA-TAC INTERNATIONAL AIRPORT  
DES MONNES WAY  
HURSBY WETLAND RESTORATION  
DEMOLITION AND GRADING  
CROSS SECTION

PROJECT NO. 2912058C4  
DRAWN BY: [Name]  
CHECKED BY: [Name]  
DATE: [Date]

SCALE: 1"=20' (HORIZONTAL), 1"=5' (VERTICAL)

DATE: 11/19/09  
PLANE: 2912058C4

APPENDIX F

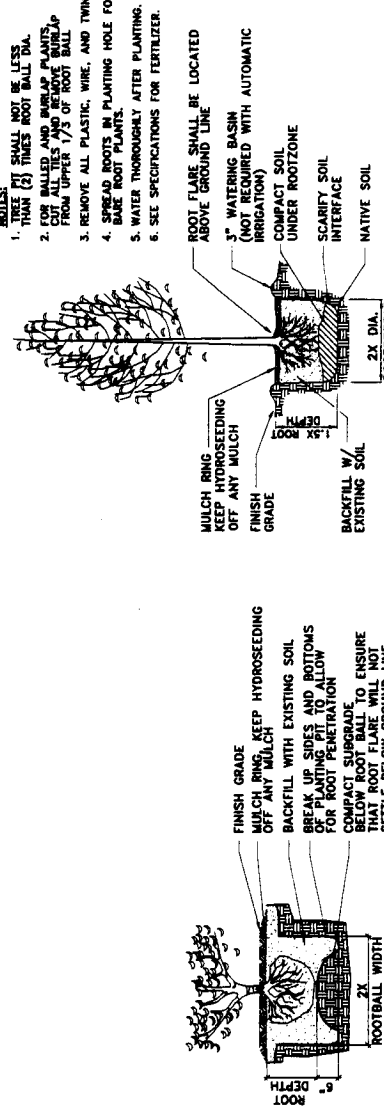






| Symbol | Botanical Name / Common Name                      | Size              | Density (Plants Per Acre) | Condition / Remarks                                                                                                                                                                      |
|--------|---------------------------------------------------|-------------------|---------------------------|------------------------------------------------------------------------------------------------------------------------------------------------------------------------------------------|
|        | <b>DES MOINES WAY NURSERY WETLAND RESTORATION</b> |                   |                           |                                                                                                                                                                                          |
|        | <b>WETLAND RESTORATION/UNASSISTED</b>             |                   |                           |                                                                                                                                                                                          |
|        | <i>Pinus strobus</i> / White spruce *             | 3'-4' H           | 80                        | - Container or BAB. Rooting to sides and bottom of can or burtop.                                                                                                                        |
|        | <i>Thuja plicata</i> / Western redcedar *         | 3'-4' H           |                           |                                                                                                                                                                                          |
|        | <i>Thuja occidentalis</i> / Eastern redcedar *    | 3'-4' H           | 2,100                     | - Container. Rooting to sides and bottom of can. Live stakes shall be 36"-48" H, 1/2"-1" dia., with a minimum of 10 viable, undamaged buds on each stake. 3-4 buds shall be below grade. |
|        | <i>Spartina patens</i> / Noddy sedge              | 1 gal.            |                           | - Spacing 4.5' O.C. typical.                                                                                                                                                             |
|        | <i>Salix zosterifolia</i> / Willow                | 1 gal./Live stake |                           |                                                                                                                                                                                          |
|        | <i>Salix rostrata</i> / Willow                    | 1 gal./Live stake |                           |                                                                                                                                                                                          |
|        | <i>Spartina anglica</i> / Hardhack spruce         | 1 gal.            |                           |                                                                                                                                                                                          |
|        | <b>UPLAND BUFFER ZONE</b>                         |                   |                           |                                                                                                                                                                                          |
|        | <i>Aster grandiflorus</i> / Great fr.             | 4'-6" H           | 280                       | - Container or BAB. Rooting to sides and bottom of can or burtop.                                                                                                                        |
|        | <i>Aster multiflorus</i> / Big leaf maple         | 4'-6" H           |                           |                                                                                                                                                                                          |
|        | <i>Aster rubrum</i> / Red aster                   | 2 gal.            |                           |                                                                                                                                                                                          |
|        | <i>Pinus strobus</i> / White spruce *             | 3'-4' H           |                           |                                                                                                                                                                                          |
|        | <i>Pinus resinosa</i> / Black whitepine           | 4'-6" H           |                           |                                                                                                                                                                                          |
|        | <i>Thuja plicata</i> / Western redcedar *         | 3'-4' H           |                           |                                                                                                                                                                                          |
|        | <i>Thuja occidentalis</i> / Eastern redcedar *    | 3'-4' H           |                           |                                                                                                                                                                                          |
|        | <i>Thuja occidentalis</i> / Western hemlock *     | 3'-4' H           |                           |                                                                                                                                                                                          |
|        | <i>Thuja occidentalis</i> / Western hemlock *     | 3'-4' H           |                           |                                                                                                                                                                                          |
|        | <i>Spartina anglica</i> / Hardhack spruce         | 3'-4' H           | 2,100                     | - Container. Rooting to sides and bottom of can.                                                                                                                                         |
|        | <i>Acer circinnatum</i> / Vine maple              | 2 gal.            |                           | - Spacing 4.5' O.C. typical.                                                                                                                                                             |
|        | <i>Acer rubrum</i> / Red maple                    | 1 gal.            |                           |                                                                                                                                                                                          |
|        | <i>Acer rubrum</i> / Red maple                    | 1 gal.            |                           |                                                                                                                                                                                          |
|        | <b>ENHANCED EXISTING WETLAND</b>                  |                   |                           |                                                                                                                                                                                          |
|        | <i>Acer circinnatum</i> / Vine maple              | 2 gal.            | 2,100                     | - Container. Rooting to sides and bottom of can. Live stakes shall be 36"-48" H, 1/2"-1" dia., with a minimum of 10 viable, undamaged buds on each stake. 3-4 buds shall be below grade. |
|        | <i>Pinus strobus</i> / White spruce *             | 1 gal.            |                           |                                                                                                                                                                                          |
|        | <i>Pinus strobus</i> / White spruce *             | 1 gal.            |                           |                                                                                                                                                                                          |
|        | <i>Pinus strobus</i> / White spruce *             | 1 gal.            |                           |                                                                                                                                                                                          |
|        | <i>Salix lucida</i> / Live stake                  | 1 gal./Live stake |                           |                                                                                                                                                                                          |
|        | <i>Salix rostrata</i> / Live stake                | 1 gal./Live stake |                           |                                                                                                                                                                                          |

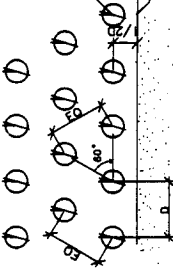
\* Western redcedar, Western hemlock and Sitka spruce shall be planted in a second planting phase, to follow year-2 monitoring. These plants shall be located by the wetland biologist in locations where partial shade and favorable soil moisture are present.



**DETAIL TREE PLANTING (TYPICAL)**

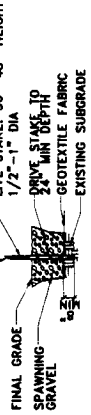
NOTE:  
ALL SHRUB SPACING SHALL BE EQUIDISTANT UNLESS OTHERWISE SPECIFIED

DISTANCE (D) ON CENTER AS REQUIRED TO MEET PLANTS PER ACRE STANDARD.  
START FIRST ROW OF PLANTING AT 1/2 THE PERPENDICULAR SPACING BETWEEN ROWS  
EDGE OF PLANTING AREA

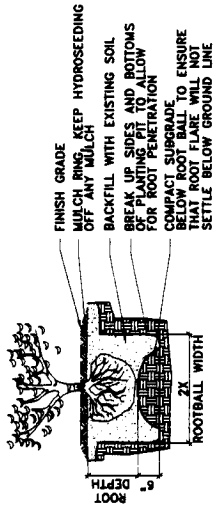


**DETAIL TRIANGULAR SHRUB SPACING (TYPICAL)**

NOTE:  
REMOVE PORTION OF LIVE STAKE DURING PLACEMENT



**DETAIL LIVE STAKE PLANTING (TYPICAL)**



**DETAIL SHRUB PLANTING (TYPICAL)**

DO THIS:  
USE IRREGULAR "PUZZLE-SHAPED" PLANT GROUPINGS

NOT THIS:  
AVOID UNIFORM PLANT GROUPINGS.

**DETAIL SHAPES OF PLANTING MASSES (TYPICAL)**

NOTES:

1. Preserve and protect all trees and shrubs not designated for removal. Provide, erect, and maintain barricades necessary to prevent access to areas within drip lines of existing trees. Allow no vehicular or pedestrian traffic, or stacking and/or storage of construction materials within barricades.
2. For each planting zone Contractor shall lay out a 10,000 sq. ft. test plot, in which the positions of all plants shall be staked with flags that are color coded to represent specific species. Layout for each zone shall be inspected and approved prior to commencement of planting. Approved staking shall serve as the plant layout standard for the remainder of each zone.
3. Shrub masses shall consist of multiple single-species groups (see detail 5). Contractor shall ensure that these single-species groups have a variety of sizes and shapes, and that shrub masses have a variety of species. See planting schedule for numbers of plants in single-species groups.
4. Hydroseed all planting areas. Re-seed areas that are disturbed by subsequent work. Keep hydroseeding off any mulch circles except where needed to protect roots of conifers.

Keep hydroseeding off any mulch

**AGENCY REVIEW**  
**NOT FOR CONSTRUCTION**

|                                                                                                                    |                                                                                                                                                  |
|--------------------------------------------------------------------------------------------------------------------|--------------------------------------------------------------------------------------------------------------------------------------------------|
| <b>DES MOINES WAY NURSERY WETLAND RESTORATION PLANTING SCHEDULE AND DETAILS</b>                                    |                                                                                                                                                  |
| <b>Part of Seattle SEA-TAC INTERNATIONAL AIRPORT</b><br><b>DES MOINES MEMORIAL WAY NURSERY WETLAND RESTORATION</b> | 100051<br>2812058L2<br>STA-9805-12                                                                                                               |
| CALL 48 HOURS BEFORE YOU DIG<br>1-800-424-5555                                                                     | <b>Parametrix, Inc.</b><br>5008 LL Washington Blvd. NE<br>Kirkland, WA 98033<br>Ph: (425) 822-8800<br>Quality Service Through Employee Ownership |
| REVISIONS<br>NO. DATE BY                                                                                           | PROJECT NO. DATE BY                                                                                                                              |