

Fendt
EXHIBIT NO 297
7-8-02
M. Green

**Low Streamflow Analysis and
Summer Low Flow Impact Offset Facility Proposal**

December 2001



Port of Seattle

**Parametrix, Inc.
Volume 1**

(Includes Main Text and Appendices B through J)

AR 019895

**LOW STREAMFLOW ANALYSIS AND SUMMER LOW FLOW
IMPACT OFFSET FACILITY PROPOSAL**

**SEATTLE-TACOMA INTERNATIONAL AIRPORT
MASTER PLAN UPDATE IMPROVEMENTS**

Prepared for

PORT OF SEATTLE
Seattle-Tacoma International Airport
17900 International Boulevard, Suite 402
Seattle, Washington 98188

Prepared by

PARAMETRIX, INC.
5808 Lake Washington Blvd. NE, Suite 200
Kirkland, Washington 98033-7350

Aqua Terra Consultants
6140 Capital Blvd. SE, Suite D
Tumwater, Washington 98501

Earth Tech, Inc.
10800 NE 8th Street, Seventh Floor
Bellevue, Washington 98004

Foster Wheeler Environmental Corporation
12100 NE 195th Street, Suite 200
Bothell, Washington 98011

HNTB
600 108th Avenue NE, Suite 400
Bellevue, Washington 98004

Pacific Groundwater Group
2377 Eastlake Avenue East
Seattle, Washington 98102

December 2001
556-2912-001 (28B)

AR 019896

CERTIFICATE OF ENGINEER

The technical material and data contained in this document were prepared under the supervision and direction of the undersigned, whose seal, as a professional engineer licensed to practice as such, is affixed below.



EXPIRES: 05-12-03

Paul S. Fendt

Paul S. Fendt, P.E.

(affix seal here)

*Low Streamflow Analysis
STIA Master Plan Update Improvements*

*December 2001
556-2912-001(28B)*

AR 019897

TABLE OF CONTENTS

	<u>Page</u>
EXECUTIVE SUMMARY.....	vi
1. INTRODUCTION.....	1-1
1.1 PURPOSE.....	1-1
1.2 ORGANIZATION OF REPORT.....	1-1
1.3 RELATIONSHIP TO OTHER DOCUMENTS.....	1-1
1.4 PROJECT DESCRIPTION.....	1-3
2. LOW STREAMFLOW ANALYSIS.....	2-1
2.1 APPROACH.....	2-1
2.1.1 Introduction.....	2-1
2.1.2 Determination of Summer Low-Streamflow Period.....	2-1
2.1.3 Existing Summer Low Streamflows.....	2-2
2.2 HSPF MODEL CALIBRATION.....	2-2
2.2.1 Overall Model.....	2-2
2.2.2 Low-Flow Review.....	2-2
2.3 EMBANKMENT MODELING.....	2-6
2.4 NON-HYDROLOGIC IMPACTS.....	2-8
2.4.1 Cessation of Water Withdrawals.....	2-8
2.4.2 Removal of Septic Tank Discharges.....	2-9
2.4.3 Summary of Non-Hydrologic Impacts.....	2-10
2.5 SUMMARY OF NET IMPACTS TO CREEKS.....	2-10
2.5.1 Summary of Flow Impacts.....	2-10
2.5.2 Summary of Water Level Impacts.....	2-13
3. MITIGATION PROPOSAL.....	3-1
3.1 INTRODUCTION OF APPROACH.....	3-1
3.2 PERFORMANCE STANDARDS.....	3-1
3.3 WATER QUANTITY – VAULT SIZING ANALYSIS.....	3-1
3.3.1 Vault Sizing.....	3-2
3.3.2 Vault Fill Time.....	3-2
3.4 WATER QUALITY DESIGN.....	3-3
3.4.1 Introduction.....	3-3
3.4.2 Turbidity.....	3-4
3.4.3 Temperature.....	3-5
3.4.4 Dissolved Oxygen.....	3-6
3.4.5 Nutrients.....	3-7
3.4.6 Metals.....	3-8
3.5 ADDITIONAL INFORMATION.....	3-9
3.6 PILOT PROGRAM PROPOSAL.....	3-11
4. OPERATION AND MAINTENANCE PLAN.....	4-1
4.1 PURPOSE AND SCOPE.....	4-1
4.1.1 Purpose of Plan.....	4-1
4.1.2 Scope of Plan.....	4-1
4.2 FACILITY DESCRIPTIONS.....	4-1
4.2.1 Facility Design and Operation Concept.....	4-1

TABLE OF CONTENTS (CONTINUED)

	<u>Page</u>
4.2.2 Facilities Overview	4-1
4.3 FACILITY OPERATION	4-2
4.3.1 System Schedules.....	4-2
4.3.2 Facility-Specific Schedules.....	4-7
4.4 INSPECTION AND MAINTENANCE.....	4-7
4.4.1 Procedures	4-7
4.4.2 Sediment Removal	4-7
4.4.3 Schedule	4-10
4.4.4 Documentation	4-10
4.4.5 Reporting.....	4-10
4.5 SAFETY	4-10
5. MONITORING PLAN	5-1
5.1 WATER QUALITY AND FLOW MONITORING	5-1
5.1.1 Characterization of Existing/Expected Water Quality.....	5-1
5.1.2 Monitoring of Annual Test Releases from the Flow Impact Offset Facility.....	5-1
5.1.3 Operational Monitoring	5-2
5.2 BIOLOGICAL MONITORING	5-4
5.2.1 B-IBI Sampling Protocol	5-4
5.2.2 Physical Habitat Monitoring Protocol	5-7
5.3 FILL MONITORING, INFILTRATION BMPS, AND INFILTRATION CONTINGENCY MEASURES	5-7
5.3.1 Existing Fill Quality Control Testing.....	5-8
5.3.2 New Infiltration Capacity Testing Protocol for Fill.....	5-8
5.3.3 Fill Infiltration Performance Criterion.....	5-10
5.3.4 Fill Infiltration BMPs.....	5-10
5.3.5 Fill Infiltration Contingency Measures.....	5-10
5.4 ADAPTIVE MANAGEMENT.....	5-11
6. REFERENCES.....	6-1

APPENDICES

A	HSPF MODELING INFORMATION AND DATA (CONTAINED IN VOLUME 2)
B	EMBANKMENT MODELING REPORT
C	EMBANKMENT INFILTRATION MEMORANDUM
D	NON-HYDROLOGIC IMPACTS SUPPORT DATA
E	HEC-RAS MODELING INFORMATION AND FIELD SURVEY DATA
F	RESERVE STORMWATER RELEASE STORAGE FACILITIES CONCEPT DRAWINGS
G	PHYSICAL HABITAT SURVEY AND MONITORING PROTOCOL FOR WADABLE STREAMS
H	LOW STREAMFLOW FISH BEHAVIOR MEMORANDUM
I	DETERMINATION OF LOW-FLOW QUANTITY IMPACTS AND MITIGATION
J	HSPF INPUT FILES FOR LOW-FLOW VAULT SIZING

LIST OF FIGURES

<u>Figure</u>	<u>Page</u>
2-1 Map of Basins with Gage Locations.....	2-4
2-2 Flow Rate Versus Depth Curve for Miller Creek.....	2-14
2-3 Flow Rate Versus Depth Curve for Walker Creek.....	2-15
2-4 Flow Rate Versus Depth Curve for Des Moines Creek.....	2-16
2-5 Changes in Average Water Depths and Widths Between the 1994 and 2006 2-Year, 7-Day Low Flows (Not Accounting for Low Flow Mitigation).....	2-17
4-1 Low Flow Impact Offset Facilities Locations.....	4-4
4-2 Walker Creek Facilities Annual Schedule.....	4-5
4-3 Des Moines Creek Facilities Annual Schedule.....	4-6
4-4 Inspection and Maintenance Process.....	4-8
4-5 Generalized Inspection and Maintenance Record.....	4-9

LIST OF TABLES

<u>Table</u>	<u>Page</u>
2-1 Miller Creek at the mouth, 7-day low flows for water-years 1991 through 1996.....	2-3
2-2 Miller Creek at the detention facility, 7-day low flows for water-years 1991 through 1996.	2-3
2-3 Walker Creek at the mouth, 7-day low flows for water-years 1993 through 1996.....	2-5
2-4 Walker Creek near wetland, 7-day low flows for water-years 1991 through 1996.	2-5
2-5 Des Moines Creek at the mouth, June through November 7-day low flows for water-years 1992 through 1996.	2-6
2-6 Des Moines Creek at gage 11c, June through November 7-day low flows for water-years 1991 through 1996.	2-6
2-7 Updated estimate of historic Miller Creek water withdrawals.....	2-9
2-8 Active buy-out area septic systems under pre-project conditions.....	2-10
2-9 Total net summer low-streamflow impacts.	2-11
2-10 Changes in average water depths and widths between the 1994 and 2006 2-year, 7-day low flows (not accounting for low-flow mitigation).....	2-13
3-1 Summer low-flow impact offset maximum vault sizes.....	3-2
3-2 Low-flow vault fill time estimates.....	3-3
4-1 Summary of low-flow impact offset facilities.....	4-3
4-2 Summary of low-flow vaults operating schedules.....	4-7

ACRONYMS AND ABBREVIATIONS

APHA	American Public Health Association
ASTM	American Society for Testing and Materials
BFW	bankfull width
B-IBI	Benthic Index of Biotic Integrity
BMPs	Best Management Practices
BOD	biological oxygen demand
°C	degrees Celsius
cf	cubic feet
cf/d	cubic feet per day
cfs	cubic feet per second
CIP	capital improvement project
cm	centimeters
DBH	diameter at breast height (4.5 ft from the ground)
DNR	Department of Natural Resources
DO	dissolved oxygen
Ecology	Washington State Department of Ecology
EPA	U.S. Environmental Protection Agency
ET	evapotranspiration
ft	feet
GIS	geographic information system
GPS	global positioning system
HSPF	Hydrologic Simulation Program – FORTRAN
IWS	Industrial Wastewater System
LWD	large woody debris
m	meter
mg/l	milligrams per liter
mm	millimeter
NEPL	North Employee Parking Lot
NPDES	National Pollutant Discharge Elimination System
NTU	Nephelometric Turbidity Unit
PAM	polyacrylamide
PIT	Pilot Infiltration Test

Port	Port of Seattle
RCU	riparian condition unit
SMP	Stormwater Management Plan
SSHEAR	Salmonid Screening, Habitat Enhancement, and Restoration
STIA	Seattle-Tacoma International Airport
SWPPP	Stormwater Pollution Prevention Plan
UEBEM	Urban Stream Baseline Evaluation Methodology
USFS	United States Forest Service
WDFW	Washington Department of Fish and Wildlife
WDNR	Washington Department of Natural Resources
WFPB	Washington Forest Practices Board

EXECUTIVE SUMMARY

This report presents the analyses performed to estimate the timing and volume of discharges to local receiving streams and wetlands during low-flow periods from Seattle-Tacoma International Airport (STIA) considering improvements defined in the Port of Seattle's Master Plan Update. This report also presents a Flow Impact Offset Facility Plan, which is the Port's proposal to offset impacts to flows in the receiving waters during annual low-streamflow periods, typically experienced in late summer/early fall. The plan is based on a detailed evaluation of the hydrologic impacts of the proposed third runway embankment and associated non-hydrologic impacts (cessation of water use and removal of septic tanks on properties purchased by the Port) on streamflow in Miller, Walker, and Des Moines Creeks. This report is submitted in response to condition I.1 of the Water Quality Certification (#1996-4-02325 [Amended - 1]) issued by the Washington State Department of Ecology (Ecology) on September 21, 2001. The report builds upon previous reports by Earth Tech (December 2000), Pacific Groundwater Group (June 2000, August 2001), and Parametrix (December 2000, July 2001). Earth Tech, Pacific Groundwater Group, Aqua Terra, HNTB, Foster Wheeler, and Parametrix prepared analyses presented in this report, and Hydrocomp contributed technical review of modeling analyses. Ecology was consulted during the development of the plan to ensure that agency concerns are addressed in this report.

Impacts to streamflow in the three streams were evaluated using a suite of modeling tools. The Hydrologic Simulation Program - FORTRAN (HSPF) was used to develop overall stormwater models of STIA (existing conditions and proposed conditions), as described in the *Comprehensive Stormwater Management Plan (SMP)* (Parametrix 2000a, 2001a). These models were also used to evaluate stormwater flows and volumes in the low-flow analysis. The hydrologic properties of the proposed third runway embankment were modeled using a combination of Hydrus and a finite-difference Slice model. Hydrus was used to simulate the movement of water between the root zone and water table in the proposed embankment, and the Slice model was used to simulate the movement of water through the saturated portion of the proposed embankment. Results of the Hydrus and Slice modeling were incorporated back into the HSPF model to estimate the post-construction flows. By comparing these results to the pre-project conditions, the impacts of the proposed embankment on streamflows were determined. Non-hydrologic impacts were then included in the impacts analysis. Statistical analyses of model output, precipitation, and streamflow data for the available period of record predicted a net low-flow impact to be mitigated during the low-flow offset period. The flow offset to be provided is 0.11 cubic feet per second (cfs) in Walker Creek and 0.08 cfs in Des Moines Creek. The project impact in Miller Creek was completely offset by seepage from the third runway embankments.

The Port's proposal to offset impacts to low streamflow is to detain excess stormwater runoff during the winter and release it to the streams during the predicted annual low-streamflow periods. Vault sizes for the volume of water required to offset the predicted impacts were determined by calculating the volume necessary to fulfill the required mitigation during the 92-day mitigation period for each year in the period of record (1949 to 1995), and selecting the year requiring the largest vault volume as the "worst case" scenario. The resulting volumes of stormwater (18.5 acre-ft¹ for Walker Creek and 13.5 acre-ft for Des Moines Creek) were incorporated into supplemental

¹ A 19.0 acre-ft vault was used for the concept design.

stormwater vaults in each watershed. These volumes of stormwater will be collected during the rainy season, stored, and discharged during the annual low-flow periods at rates equal to the predicted impact in each stream. Several considerations are proposed to be included in the design of these vaults to allow the management of stormwater discharges to offset the predicted low-flow impacts. Additional considerations in the design and operation of the proposed stormwater vaults to improve the water quality of discharges will also be included. An analysis of the availability of stormwater required to fill the vaults showed that even during the driest years in the period of record, enough water can be collected and stored to offset the impacts to streamflow during the annual low-streamflow period.

Key goals and objectives (performance standards) of the proposed Flow Impact Offset Facility include:

- Provide flow at the rates required to offset the predicted impacts of the proposed embankment for the entire annual low-streamflow period each year (approximately 92 days from late July through the end of October).
- Operate and maintain the facility to maintain water quality during the annual low-streamflow periods.
- Design the facility and its operation, monitoring, and maintenance plan so that an adaptive management strategy can be applied.

As stated in Ecology's *Stormwater Management Manual for Western Washington* (Ecology 2001), the objective of stormwater management is to "control the quantity and quality of stormwater produced by new development and redevelopment such that they comply with water quality standards and contribute to the protection of beneficial uses of the receiving waters." Ecology has determined that stormwater management activities in Washington do not require a water right. Since the Port's proposal to offset flow impacts to the receiving waters consists of stormwater management activities, a water right is not required for the Flow Impact Offset Facility.

1. INTRODUCTION

1.1 PURPOSE

The purpose of this report is to evaluate impacts to streamflows in Miller, Walker, and Des Moines Creeks resulting from construction projects included in the Master Plan Update for Seattle-Tacoma International Airport (STIA), and to propose a Flow Impact Offset Facility to mitigate potential impacts during summer low-streamflow periods. Placement of new impervious surfaces and embankment fill, combined with removal of septic tanks and cessation of existing water uses in the embankment area, will impact the timing and amount of groundwater flows to the streams. While these impacts vary seasonally, they are expected to be most significant during late summer/early fall, when streamflows are typically at their lowest. This document presents the analysis that was completed to determine the impacts (both positive and negative) to streamflows, and to propose a facility and management/operation plan to offset those impacts during the annual low-streamflow periods.

1.2 ORGANIZATION OF REPORT

This report is organized into six sections. Section 1 contains an introduction. Section 2 describes the analysis undertaken to determine the impacts to streamflows in each stream. Surface water modeling, embankment modeling, and the effects of "non-hydrologic" impacts are discussed. The proposal for the Flow Impact Offset Facility is described in Section 3, including discussions of vault sizing, water quality management, performance standards, and a pilot program. Section 4 contains the Operation and Maintenance Plan for the Flow Impact Offset Facility. Section 5 contains the monitoring plan, addressing both operation of the facility and its impacts to the streams. References are listed in Section 6.

Ten appendices containing additional technical information are included. Appendix A is contained in Volume 2, and Appendices B through J are located in Volume 1 behind the main text. Appendix A provides HSPF modeling information and data, including low-flow review of the HSPF model calibration, land use tables, and HSPF input files. The technical report describing the embankment modeling analysis is contained in Appendix B. Appendix C provides information on infiltration into the embankment. Data used in the assessment of the non-hydrologic impacts is provided in Appendix D. Appendix E contains HEC-RAS modeling results and stream cross-section field survey data. Concept drawings of the reserved stormwater system (vaults, routing, discharge locations, etc.) are contained in Appendix F. Appendix G presents additional information on physical habitat monitoring protocol in streams. A memorandum on low streamflow fish behavior is provided in Appendix H. Appendix I contains information on the determination of low-flow quantity impacts and mitigation. The HSPF input files for the low-flow vault sizing are provided in Appendix J.

1.3 RELATIONSHIP TO OTHER DOCUMENTS

This report, which replaces and updates the *Low Streamflow Analysis* prepared by Earth Tech, Inc. in December 2000 (Earth Tech, Inc. 2000) and the *Low Flow Analysis Flow Impact Offset Facility Proposal* prepared by the Port of Seattle in July 2001 (Port of Seattle 2001a), is referred to in

Sections 6.2.1 and 7.7.5 of the *Comprehensive Stormwater Management Plan, Master Plan Update Improvements, Seattle-Tacoma International Airport* (SMP; Parametrix, Inc. 2000a, 2001a).

The Clean Water Act Section 401 water quality certification was issued by the Department of Ecology on August 10, 2001, and amended on September 21, 2001, subsequent to the submittal of the July 2001 Low Flow Analysis/Flow Impact Offset Facility Proposal (Water Quality Certification #1996-02325 [Amended - 1]). The amended certification required the submittal of a revised Low Flow Analysis/Flow Impact Offset Facility Proposal addressing a number of issues listed in Section I of the amended certification. Additional model runs were required to address some of these issues. During the additional modeling, some errors in data handling were detected. While corrections of these errors do not change the modeling approach, the underlying assumptions, or the calibration, they do impact the results of the modeling analysis. Discussions were held between the Port, its consultants, Ecology, and King County to discuss the errors and their resolution, which are summarized below:

1. Different models were used to simulate different parts of the hydrology of the embankment area. This required data to be transferred back and forth between the different models. In one data transfer, a conversion factor (from daily to hourly flows) was inadvertently applied twice. The result was that modeled flow from the embankment was 1/24 of what it should have been. This error was corrected by applying the conversion factor once in the revised modeling.
2. In another data transfer, an incorrect file ("daily AGWO") was used, where another file ("hourly AGWT") should have been used. This error was corrected by transferring the correct file.
3. When the original model was developed, a number of alternatives to model the impervious areas tributary to the filter strips on top of the proposed embankment were considered. With the change implemented in No. 2 above, a more direct way to model this area became possible. In the original modeling, rainfall on the pervious area was "scaled up" to address the impervious area and flow to the filter strips. In the revised modeling, flow to the filter strips will be calculated based on the "AGWT" and "SURO" time series data.
4. In the original modeling, a two-dimensional version of the Hydrus model was used to calculate one-dimensional (vertical) flows through the proposed embankment. Since the revised modeling results in more water flowing through the embankment, a one-dimensional version of Hydrus was used because it is better able to simulate the more varied saturation conditions.
5. In the original modeling, infiltration from infiltration basins was not simulated because it was negligible. In the revised modeling, more water is available to the infiltration basins; therefore, this flow is no longer negligible. The revised modeling will simulate and document this flow, which will be routed to the groundwater component of the HSPF modeling.
6. In the original modeling, all groundwater from pervious areas in the SDS5, SDS6, and SDS7 basins was inadvertently routed to Des Moines Creek in the pre-developed

conditions model. In the post-developed conditions model, groundwater from these areas was correctly routed to Walker Creek. This error was corrected by routing the groundwater in these areas to Walker Creek in the pre-developed conditions model.

An additional revision to the modeling was discussed with Ecology and King County, but was not incorporated into the revised model. This revision involved routing the "seepage to till" component of the embankment flow directly to the stream. The group concluded that the existing approach was a more accurate way to model this flow component.

1.4 PROJECT DESCRIPTION

The Port's proposal is to collect excess stormwater during the rainy season, store it in underground vaults, and release the stored water continuously into each stream during the designated summer low-streamflow period at a rate equivalent to the calculated summer low-streamflow impact to that stream from planned Port projects. The summer low-streamflow impacts in each stream were determined through detailed modeling analyses. The summer low-streamflow periods were determined through statistical analyses of modeled streamflow from the calibrated HSPF models and consultations with biologists on the effects of low-streamflow periods on stream biology.

The facility, as designed, consists of two stormwater vaults (one vault providing water to offset flow impacts in Walker Creek and one vault providing water to Des Moines Creek). Each of these vaults stores stormwater during the rainy season to be released during the summer low-streamflow periods with features that are unique to low-flow vaults. The extra features consist of additional outlets and controls, floating discharge structures to maintain constant discharge rates, varying configurations to manage sediments, and additional water quality management features (ventilation to facilitate aeration, provisions for filtration and mechanical aeration of discharges, and oil/water separation, as appropriate). Generally, water will be collected beginning in January of each year, and discharged from late July through October (with discharges continuing through November depending on the availability of water). Annual facility maintenance will take place in December of each year.

2. LOW STREAMFLOW ANALYSIS

2.1 APPROACH

2.1.1 Introduction

The low-streamflow analysis approach included the determination of the critical low-streamflow periods for each stream, determination of existing streamflow magnitudes (target streamflows), and the determination of impacts to each stream resulting from construction projects in the Master Plan Update for STIA. The evaluations of the summer low-streamflow periods and rates are described in Sections 2.1.2 and 2.1.3. A detailed modeling analysis was used to determine the impacts to streamflows during the summer low-streamflow periods. Modeling tools used include the calibrated Hydrologic Simulation Program – FORTRAN (HSPF; EPA 1997) models for Miller, Walker, and Des Moines Creeks. HSPF model calibration is described in Section 2.2, and detailed HSPF model and calibration information is contained in Appendices A and B (Volumes 2 and 3) of the SMP (Parametrix 2000a, 2001a). The impacts of the proposed third runway embankment were modeled using a combination of Hydrus (Simunek et al. 1999) and Slice models. The embankment modeling is described in Section 2.3, and the complete embankment modeling report (Pacific Groundwater Group 2001) is contained in Appendix B. Non-hydrologic impacts, including cessation of water withdrawals and removal of septic tank discharges, are described in Section 2.4. The total net summer low-streamflow impacts are summarized in Section 2.5.

2.1.2 Determination of Summer Low-Streamflow Period

Determination of the low-streamflow period for each stream was done by analyzing modeled streamflow from the calibrated HSPF model for each stream, which used 1994 (existing) land use conditions. This determination is summarized below, and supporting information is provided in Appendix I.

The 7-day low-flow period for each year (using 1994 flow conditions) in the 47-year period of record (1949 to 1995) for each stream was determined at points of compliance near the airport (200th Street in Des Moines Creek, SR 509 in Miller Creek, and at the outlet of the wetland near Des Moines Memorial Drive in Walker Creek). The 7-day low flow was selected as an indicator of persistent dry season flow. For example, summer low streamflows tend to decrease gradually; therefore, a shorter low-streamflow period is unlikely to result in significantly lower average flows or target flows. In addition, consultation with biologists concluded that summer low flows with durations of less than 2 weeks do not affect the carrying capacity of the streams or cause behavioral changes in salmonids (Appendix H).

The occurrences of the annual 7-day low-flow periods were plotted and a bar graph showing the distribution of the summer low-flow periods by date was developed for each stream. The summer low-streamflow period for each stream was selected to include all the historical 7-day low-flow occurrences.

2.1.3 Existing Summer Low Streamflows

The magnitude of existing summer low streamflow (target streamflow) in each stream was determined through analysis of the 7-day low-flow periods under existing (1994) conditions described above. The annual 7-day low flows for each stream were ranked, and recurrence intervals were determined based on this ranking using a cumulative density function (see Appendix I for supporting information). The 7-day low flow with a 2-year (50 percent) recurrence interval was selected as the streamflow target in each stream. The 2-year, 7-day low flow was selected because the magnitude of the estimated impact to 7-day low flows generally decreases with greater recurrence interval (i.e., the estimated reduction in the 7-day, 2-year-frequency low-flow rate is greater than that for the 7-day, 10-year-frequency low-flow rate). Therefore, providing mitigation equivalent to the 7-day, 2-year-frequency impact will provide mitigation sufficient to mitigate the more extreme summer low-streamflow events. Based on this analysis, the existing summer low streamflows (target streamflows) (7-day, 2-year frequency) were determined to be 0.33 cfs for Des Moines Creek, 0.77 cfs for Walker Creek, and 0.73 cfs for Miller Creek.

2.2 HSPF MODEL CALIBRATION

2.2.1 Overall Model

The computer program HSPF was used to simulate continuous watershed hydrology and to design stormwater detention facilities for the Port's Master Plan Update at STIA. Because the airport encompasses three watersheds, separate HSPF models for Miller, Walker, and Des Moines Creeks were developed. Hydrological modeling using HSPF requires the calibration of many parameters that describe the different hydrologic processes. These processes include:

- Rainfall runoff from pervious and impervious surfaces.
- Infiltration of rainfall to soils.
- Soil moisture accounting.
- Flow of groundwater from soils to streams.
- Loss of groundwater to deep aquifers.

Each of these physical processes is controlled by several parameters. The calibration process adjusts model parameters to achieve a close match between recorded streamflows and simulated streamflows for a period when streamflow data are available. Calibration of the HSPF models used for Miller, Walker, and Des Moines Creek watersheds is described in detail in Appendix B (Volume 3) of the SMP (Parametrix 2000a, 2001a).

2.2.2 Low-Flow Review

The overall HSPF model calibration effort did not focus specifically on low-streamflow periods. The low-flow analysis consisted of review of data from water-years 1991 through 1996, with the low-flow period considered to be June through November. This section summarizes the results of the overall HSPF model calibration for Miller, Walker, and Des Moines Creek watersheds as related to the low-flow analysis. Detailed information on the low-flow calibration review is provided in Appendix A.

2.2.2.1 Miller Creek Low Streamflow

Two streamflow gages located in the Miller Creek watershed were used in the low-streamflow analysis calibration review (Figure 2-1). One of these streamflow gages was located near the mouth of Miller Creek, and the other was located further upstream at the Miller Creek detention facility.

Average simulated and observed streamflows for each 7-day low-flow period during 1991 through 1996 are listed in Table 2-1 for the gage near the mouth and Table 2-2 for the gage at the Miller Creek detention facility. In general, the observed 7-day low flows exceeded the predicted 7-day low flows at both gages, particularly for the gage located at the Miller Creek detention facility.

Table 2-1. Miller Creek at the mouth, 7-day low flows for water-years 1991 through 1996.

Water-Year	Observed Average Flow (cfs)	Calibrated Average Flow (cfs)	Difference (cfs)
1991	1.348	1.749	-0.401
1992	1.457	1.390	0.067
1993	1.639	1.300	0.339
1994	1.361	1.100	0.261
1995	1.500	1.661	-0.161
1996	2.762	2.138	0.624
Average Difference	2.517	2.335	0.182

Table 2-2. Miller Creek at the detention facility, 7-day low flows for water-years 1991 through 1996.

Water-Year	Observed Average Flow (cfs)	Calibrated Average Flow (cfs)	Difference (cfs)
1991	0.400	0.150	0.250
1992	0.127	0.124	0.004
1993	0.190	0.110	0.080
1994	0.000	0.090	-0.090
1995	0.183	0.137	0.045
1996	0.263	0.189	0.074
Average Difference	0.291	0.200	0.091

2.2.2.2 Walker Creek Low Streamflow

Two streamflow gages located in the Walker Creek watershed were used in the low-streamflow calibration review (see Figure 2-1). One of these streamflow gages was located near the mouth of Walker Creek, and the other was located further upstream near a wetland.

Basin Segment Descriptions
for Slice Embankment Segments

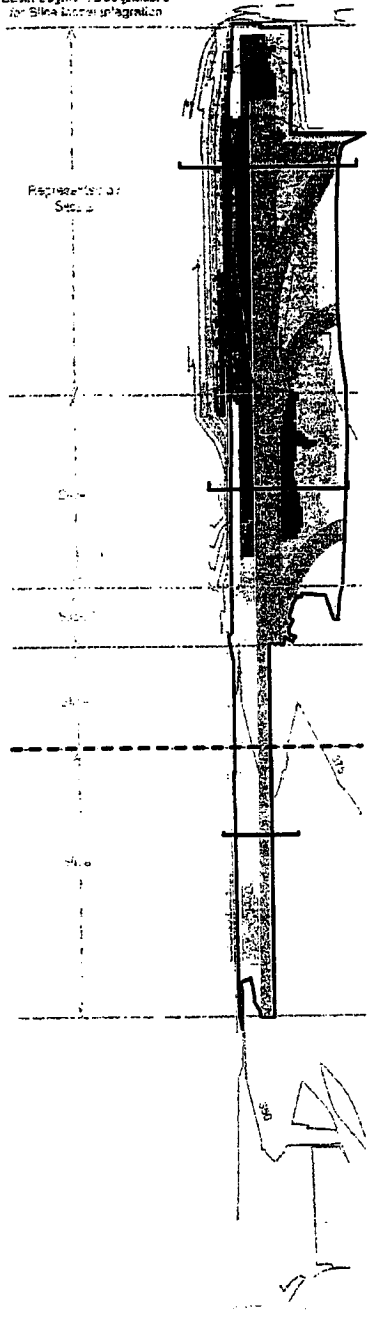

Cross Section 2 for Slice 2
(See Figure 5-2)

Cross Section 1 for Slice 1
(See Figure 5-1)



Watershed Divide between
Miller Creek and Walker Creek

Cross Section 3 for Slice 3
(See Figure 5-3)

I:\projects\019911\019911.dwg 11/11/00 11:00 AM 019911.dwg

Depth of Fill (feet)

0 - 20
21 - 40
41 - 60
61 - 80
81 - 100
101 - 120
121 - 140
141 - 160

-  Approximate Area Modeled by Hydrus and Slice (Clipped from HSPF)
-  Impervious Area
-  "Built" Elevation Contours (25 ft interval)

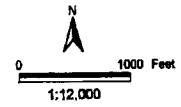

Figure 2-1

Site Features for
Hydrus-Slice Modeling

SeaTac Third Runway
Embankment FSI Modeling
JE0105



Average simulated and observed streamflows for each 7-day low-flow period are listed in Table 2-3 (1993 through 1996) for the gage near the mouth and Table 2-4 (1991 through 1996) for the gage near the wetland. In general, with the exception of 1995, the observed 7-day low flows exceeded the predicted 7-day low flows at both gages.

Table 2-3. Walker Creek at the mouth, 7-day low flows for water-years 1993 through 1996.

Water-Year	Observed Average Flow (cfs)	Calibrated Average Flow (cfs)	Difference (cfs)
1993	1.502	0.923	0.579
1994	0.987	0.833	0.154
1995	0.915	1.077	-0.163
1996	1.719	1.287	0.432
Average Difference	1.281	1.030	0.250

Table 2-4. Walker Creek near wetland, 7-day low flows for water-years 1991 through 1996.

Water-Year	Observed Average Flow (cfs)	Calibrated Average Flow (cfs)	Difference (cfs)
1991	1.208	0.786	0.422
1992	1.098	0.682	0.416
1993	0.800	0.666	0.134
1994	0.670	0.614	0.056
1995	0.256	0.750	-0.494
1996	0.896	0.870	0.026
Average Difference	0.656	0.725	-0.069

2.2.2.3 Des Moines Creek Low Streamflow

Two streamflow gages located in the Des Moines Creek watershed were used in the low-streamflow calibration review (see Figure 2-1). One of these streamflow gages was located near the mouth of Des Moines Creek, and the other gage (11c) was located further upstream.

Average simulated and observed streamflows for each 7-day low-flow period are listed in Table 2-5 (1992 through 1996) for the gage near the mouth and Table 2-6 (1991 through 1996) for gage 11c. In general, the observed 7-day low flows were close to the predicted 7-day low flows at the gage near the mouth, while the observed 7-day low flows at gage 11c exceeded the predicted 7-day low flows.

2.2.2.4 Summary

Low-streamflow analysis calibration review was performed for two gage locations in Miller, Walker, and Des Moines Creeks. Results generally indicated that calibrated low flows at the mouth of each stream were fairly good, while calibrated low flows at the upstream gages typically showed lower flows than observed flows. Groundwater conditions in each of the watersheds are somewhat speculative and may account for these discrepancies at the upstream gage locations.

Table 2-5. Des Moines Creek at the mouth, June through November 7-day low flows for water-years 1992 through 1996.

Water-Year	Observed Average Flow (cfs)	Calibrated Average Flow (cfs)	Difference (cfs)
1992	0.585	0.904	-0.318
1993	1.205	0.900	0.305
1994	0.600	0.700	-0.100
1995	1.284	1.000	0.284
1996	1.268	1.411	-0.144
Average Difference	1.089	1.003	0.086

Table 2-6. Des Moines Creek at gage 11c, June through November 7-day low flows for water-years 1991 through 1996.

Water-Year	Observed Average Flow (cfs)	Calibrated Average Flow (cfs)	Difference (cfs)
1991	0.300	0.100	0.200
1992	0.172	0.090	0.082
1993	0.133	0.100	0.033
1994	0.046	0.100	-0.054
1995	0.300	0.100	0.200
1996	0.301	0.100	0.201
Average Difference	0.195	0.100	0.095

2.3 EMBANKMENT MODELING

This section summarizes the modeling analysis done to estimate impacts of the proposed third runway embankment on streamflows in Miller and Walker Creeks. The complete report is included in Appendix B.

The third runway embankment will be constructed in the Miller and Walker Creek watersheds; therefore, this analysis was not conducted for Des Moines Creek. Impacts to the streamflows in Miller and Walker Creeks from the embankment were estimated to determine the overall impacts of the runway project. The HSPF models alone are not capable of accurately simulating groundwater flows of this type; therefore, additional modeling tools (Hydrus and Slice) were used to simulate flow through the proposed embankment in the Miller and Walker Creek watersheds. The embankment modeling expanded on a previous modeling effort (Pacific Groundwater Group 2000).

The approach used in areas to be covered by the embankment included: (1) calculating the recharge from the HSPF models using regional parameters; (2) modeling the variable saturated vertical flow within the fill using Hydrus; (3) modeling saturated, quasi-horizontal flow at the bottom of the embankment using Slice; (4) integrating the Slice results across the fill embankment; and (5) incorporating the results back into the Miller and Walker Creek HSPF models. This section summarizes steps two through four. Specific tasks included:

- Compiling model input, including:
 - Fill thickness and areal extent.
 - Hydrogeologic data for the fill area.
 - Embankment geometries as represented by three hydrogeologic cross-sections.
- Calculating daily flux into the fill based on recharge estimates.
- Calculating daily flux through the fill using Hydrus models.
- Calculating daily flux through the embankment drain layer and the underlying till using Slice models applied to each basin.

Existing geographic information system (GIS) coverages were used to determine pre-fill topography, "built" (post-construction) topography, and pavement distribution for the third runway. Fill thickness was calculated by subtracting GIS coverages of pre-fill topography from the "built" topography. Thicknesses ranged up to 160 ft, and were discretized into 20-ft sections for the Hydrus model.

Although the Des Moines Creek basin was not included in the analysis (because only a very small amount of runway embankment is in the Des Moines Creek basin), its boundaries were used to define the southern extent of the Walker Creek basin. Impervious areas comprised 36 and 38 percent of the modeled fill areas in Miller and Walker Creek basins, respectively.

Precipitation on the modeled fill area was used to calculate hourly runoff (SURO) from impervious surfaces (runway and taxiways) and hourly infiltration (AGWI) into pervious areas with a generic application of HSPF. Pervious areas were modeled as grass on flat outwash. This approach was selected, with agreement from Ecology and King County, to take advantage of HSPF's superior evapotranspiration (ET) and runoff modeling capabilities. For pervious areas, the generic HSPF model yielded hourly volumes of water that infiltrate beyond the bottom of the root zone (AGWI) and therefore constitute groundwater recharge. That calculation was applied to filter strips and other pervious areas. A separate calculation then estimated the extent to which runoff from impervious surfaces would also infiltrate, or conversely, runoff from, the filter strips. The total amount of infiltration into filter strips (a portion of AGWI and SURO) and other pervious areas (AGWI only) was then used as input to the Hydrus models. Calculated runoff was accounted for but not used in groundwater modeling.

Hydrus simulates the vertical spreading of recharge fronts as they are predicted to move downward through the proposed embankment fill. Hydrus models were set up to simulate a total of 12 vertical profiles of varying thicknesses for the proposed embankment (eight in the Miller Creek watershed and four in the Walker Creek watershed). Model timesteps were optimized by Hydrus, which were typically on the order of 0.1 day. The models were run for water-years 1984 through 1994, with only the last 4 water-years comprising the test period. Hydrus results indicated that substantial lagging and dampening (spreading) of seasonal recharge is likely within the fill, with the amount of lagging and dampening increasing with increasing fill thickness. Discharge at the bottom of the fill is predicted to occur throughout the year. Hydrus output was used as recharge input to the Slice models.

Three finite-difference Slice models were developed to simulate horizontal and vertical groundwater flow within the embankment drain layer and existing soils below the embankment. Slice configurations were based on subsurface data contained in available geotechnical and hydrogeologic reports and from the pre-fill and "built" topography of the third runway area. Slice alignments were located based on the availability of subsurface data describing the range of hydrogeologic and fill conditions in the embankment area. The Slice models were used to accumulate recharge in the shallow water table aquifer and move it downgradient to the Miller Creek or Walker Creek wetlands under the "built" conditions.

Slice 1 is located through the thickest portion of the fill embankment. Slice 2 is located near the northern end of the proposed third runway and represents an intermediate fill thickness. Slices 1 and 2 are both located in the Miller Creek basin. Slice 3 is located in the Walker Creek basin and represents an intermediate fill thickness. Locations and cross-sections of each Slice are provided in Appendix B.

Model results show that the lagtime (seasonal delay) between drain recharge peaks and drain outflow peaks is controlled by the width of fill along the groundwater flowpath represented by a slice, and are also likely influenced by the varying spatial distribution and timing of recharge inflow along each slice.

Groundwater discharge quantities for Miller and Walker Creeks were calculated by multiplying unit-width flow quantities from each representative Slice model by an effective basin length. The effective basin length associated with each slice depends on the length of the basin with characteristics similar to the slice (i.e., thickness and lateral extent). This process integrated the Slice results over the entire length of the embankment.

Estimated annual maximum drain outflows from the fill in the Walker Creek basin for the test period ranged from approximately 1,500 to 3,500 cubic feet per day (cfd). Maximum integrated fill seepage rates from below the embankment in the Walker Creek basin range from approximately 2,200 to 2,400 cfd in the 4-year test period. Estimated annual maximum drain outflows from the fill in the Miller Creek basin for the test period range from approximately 8,000 to 18,000 cfd. Integrated fill seepage rates from below the embankment in the Miller Creek basin range from approximately 7,000 to 16,000 cfd. All results of the embankment modeling analysis are discussed in detail in Appendix B.

2.4 NON-HYDROLOGIC IMPACTS

The following subsections describe non-hydrologic impacts, including cessation of water withdrawals and removal of septic tank discharges. Additional supporting information for the non-hydrologic impacts is provided in Appendix D.

2.4.1 Cessation of Water Withdrawals

Based on assumptions regarding residential and farm property uses of water rights described in the SMP (Parametrix, Inc. 2000a, 2001a), it was concluded that historic irrigation season consumption totaled 0.042 cfs within the Miller Creek buy-out area. Table 2-7 summarizes the withdrawal estimates following consultation with former owners.

Table 2-7. Updated estimate of historic Miller Creek water withdrawals.

Parcel	Last Name	Available Pumping Rate (gpm)	Acres	Months of Use Per Year	Estimated Pumping Rate (gpm)	Updated Usage Estimate (cfs)	Comments from Owner Consultations
068R	Genzale	2.5	4	5	0.52	0.001	4 acres, 2.5 gpm June to mid-October
185R	Berry	5	1	6	1.25	0.003	Less than 1 acre, summer only
244R	Randall	5	0.5	6	1.25	0.003	Only in summer/garden
097R	Smith	20	0.6	4	3.33	0.007	Pump 4 months for orchard, lawn and garden
311R	Rhoton	5	1.7	6	1.25	0.003	Water in summer - unknown quantity
316R	Roullard	0	0.25			0.000	1940-1960 maximum, 1990's no water usage
050R	Eisiminger	0	0.75			0.000	None to very little
246R	Galando	0	3.5			0.000	Unknown - doesn't remember pumping water
093R	Raffo	0				0.000	
055R	Mason	0				0.000	Municipal water
060R	Vacca	0				0.000	Municipal water
061R	Vacca	0				0.000	Municipal water
143R	Brate	0	1			0.000	Water right not used
182R	Illes	0	1			0.000	Water right not used
253R	Kobela	0	0.5			0.000	Water right not used
298R	Warner	0				0.000	Water right not used
302R	Lopez	0				0.000	Water right not used
062R	Scarsella	0	1.2			0.000	Water right not used
142R	Wind of the Willows	0	0.75			0.000	Water right not used
214R	Kamp	20		6	5	0.011	
321R	Beaudin	20		6	5	0.011	
088R	Goodmansen					0.000	
322R	Longridge	4.5		6	1.12	0.003	
TOTAL						0.042	

2.4.2 Removal of Septic Tank Discharges

Many of the residential properties in the buy-out area within Miller and Walker Creek watersheds were served by active septic systems during the pre-project conditions in 1994. These septic systems received water imported from outside of the watershed through water districts and discharged effluent through drain fields that recharge groundwaters that contribute flows to the

streams. Within the buy-out area, available records show that there were 41 residences actively served by septic systems in the Walker Creek basin, and there were 236 residences actively served by septic systems in the Miller Creek basin. Table 2-8 summarizes septic system counts for the pre-project condition analysis.

Table 2-8. Active buy-out area septic systems under pre-project conditions.

	Miller Creek	Walker Creek	Total
Residences with septic systems	249	42	291
Inactive systems (served by sewer)	13	1	14
Active septic systems	236	41	277

Based on consultation with water districts serving the buy-out area, it was concluded that winter residential water consumption averaged approximately 975 cf per month, while summer consumption averaged approximately 1,450 cf per month. The flow effectively discharged from each septic system to groundwater was estimated to equal 90 percent of the average winter water consumption, or 878 cf per month. Consistent with the hydrologic modeling of the Walker and Miller Creek basins for the SMP, approximately 30 percent of this recharge would be lost to the deeper aquifer and not available for discharge to the stream; therefore, the effective rate of base flow contribution to a stream from a residential septic system in 1994 was estimated to be 70 percent of the 878-cf-per-month septic-system discharge, or 614 cf per month.

Applying this recharge rate to the 41 active septic systems in Walker Creek produces an average daily contribution to streamflow of 0.0100 cfs. For the 236 active septic systems in Miller Creek, the resulting average daily contribution would be 0.0574 cfs.

2.4.3 Summary of Non-Hydrologic Impacts

For Miller Creek, the combined non-hydrologic impacts to low streamflows from Port projects includes a 0.06-cfs reduction (rounded from 0.0574) from discontinued septic tank discharges, and a 0.04-cfs increase (rounded from 0.042) in low flows due to cessation of water withdrawals. The net non-hydrologic impact for Miller Creek is a 0.02-cfs reduction in low streamflows. For Walker Creek, the non-hydrologic impact to low streamflows from Port projects is a 0.01-cfs reduction from discontinued septic tank discharges.

2.5 SUMMARY OF NET IMPACTS TO CREEKS

2.5.1 Summary of Flow Impacts

The net effects to flow during the summer low-streamflow periods were determined by comparing the modeled streamflow before project construction to modeled streamflow after project construction, with non-hydrologic impacts included as appropriate. Based on the analyses described in Sections 2.1 through 2.4, total net summer low-streamflow impacts that the Port proposes to offset throughout the summer low-streamflow periods are shown in Table 2-9. The net flow impact results are summarized in Sections 2.5.1.1 through 2.5.1.3 for each stream.

Table 2-9. Total net summer low-streamflow impacts.

Stream	Hydrologic Impact (cfs)	Non-Hydrologic Impact (cfs)	Total Net Streamflow Impact (cfs)
Miller Creek	+0.03	-0.02	+0.01
Walker Creek	-0.10	-0.01	-0.11
Des Moines Creek	-0.08	0.00	-0.08

2.5.1.1 Miller Creek Summary

HSPF was used to evaluate the change in low streamflow from 1994 to 2006 conditions. The Miller Creek HSPF modeling information and data, including land use tables and HSPF input files, are provided in Appendix A. Groundwater basin boundaries for Miller Creek were located to allocate the groundwater flow contributions (Appendix A).

In Miller Creek, the analysis of low streamflows needed to account for the effects of discharges from the proposed runway embankment to fully account for future post-project conditions. In areas where embankment is proposed, the quantity of precipitation infiltrating into the embankment was calculated using the 2006 condition HSPF model. The recharge was then input to the Hydrus and Slice models, which simulated the spreading of recharge fronts vertically through the embankment and laterally through the underdrain layer. Output from the Hydrus and Slice models was then input back into the HSPF model to determine the quantity and timing of discharge from the underdrain layer and the effects on contributions to low streamflows in Miller Creek. The embankment fill modeling using the Hydrus and Slice technique is described in Section 2.3, and the complete embankment modeling report (Pacific Groundwater Group 2001) is contained in Appendix B.

To assess the low-streamflow impacts in Miller Creek, the pre- and post-project conditions were modeled for 1991 through 1994. This period was selected as a representative dry period in the precipitation record during which stream gage data is available for Miller Creek. Output from the HSPF model was analyzed to determine the annual 7-day low streamflows for each of the 4 years. To determine the impact between 1994 low streamflows and 2006 flows, the 1994 and 2006 7-day low-flow values were plotted by their probability positions corresponding to the same probability positions of the years 1991 through 1994 in the 1994 pre-project condition (the full period of record [1949 to 1995] was simulated to determine the 50th percentile 7-day low flow). The separation of the 1994 and 2006 plot positions at the 50 percent probability was used as the low-flow impact requiring mitigation. The 1994 condition 50th percentile 2-year, 7-day low streamflow is 0.73 cfs, and the corresponding 2006 condition 50th percentile low streamflow is 0.76 cfs. Therefore, in Miller Creek, the estimated low-streamflow hydrologic impact due to the Port's projects, including effects of discharge from the embankment, is an increase of 0.03 cfs.

Combining the non-hydrologic impact (-0.02 cfs, as described in Section 2.4) with the hydrologic impact results in a total net summer low-streamflow increase of 0.01 cfs for the Miller Creek basin. Since there is not a reduction in low flows, no low-flow mitigation is proposed. However, monitoring and contingency measures described in Section 5 will apply in Miller Creek.

2.5.1.2 Walker Creek Summary

HSPF was used to evaluate the change in low streamflow from 1994 to 2006 conditions. The Walker Creek HSPF modeling information and data, including land use tables and HSPF input files, are provided in Appendix A. Groundwater basin boundaries for Walker Creek were located to allocate the groundwater flow contributions (Appendix A).

In Walker Creek, the analysis of low streamflows needed to account for the effects of discharges from the proposed runway embankment to fully account for future post-project conditions. In areas where embankment is proposed, the quantity of precipitation infiltrating into the embankment was calculated using the 2006 condition HSPF model. The recharge was then input to the Hydrus and Slice models, which simulated the spreading of recharge fronts vertically through the embankment and laterally through the underdrain layer. Output from the Hydrus and Slice models was then input back into the HSPF model to determine the quantity and timing of discharge from the underdrain layer and the effects on contributions to low streamflows in Walker Creek. The embankment fill modeling using the Hydrus and Slice technique is described in Section 2.3, and the complete embankment modeling report (Pacific Groundwater Group 2001) is contained in Appendix B.

To assess site low-streamflow impacts in Walker Creek, the pre- and post-project conditions were modeled for 1991 through 1994. This period was selected as a representative dry period in the precipitation record during which stream gage data is available for Walker Creek. Output from the HSPF model was analyzed to determine the annual 7-day low streamflows for each of the 4 years. To determine the impact between 1994 low streamflows and 2006 flows, the 1994 and 2006 7-day low-flow values were plotted by their probability positions corresponding to the same probability positions of the years 1991 through 1994 in the 1994 pre-project condition (the full period of record [1949 to 1995] was simulated to determine the 50th percentile 7-day low flow). The separation of the 1994 and 2006 plot position at the 50 percent probability was used as the low-flow impact requiring mitigation. The 1994 condition 50th percentile 2-year, 7-day low streamflow is 0.77 cfs, and the corresponding 2006 condition 50th percentile low streamflow is 0.67 cfs. Therefore, in Walker Creek, the estimated low-streamflow impact due to the Port's projects, including the effects from discharge from the embankment, is 0.10 cfs.

The combined hydrologic and non-hydrologic impact to low streamflows is the sum of the 0.10-cfs hydrologic reduction and a 0.01-cfs reduction from discontinued septic system discharges, for a total reduction of 0.11 cfs. This flow rate equates to the magnitude of offset flow that will be provided during the low-streamflow period for Walker Creek.

2.5.1.3 Des Moines Creek Summary

HSPF was used to evaluate the change in low streamflow from 1994 to 2006 conditions. The Des Moines Creek HSPF modeling information and data, including land use tables and HSPF input files, are provided in Appendix A. Groundwater basin boundaries for Des Moines Creek were located to allocate the groundwater flow contributions (Appendix A).

In Des Moines Creek, 2006 land use conditions ("post-project") were modeled for the full 1949 to 1995 period of record. The 7-day low flow for each year was selected and ranked, and the

streamflow with a 2-year recurrence interval was determined. In Des Moines Creek, the 2-year post-project summer low streamflow is 0.26 cfs². The impact to streamflow from proposed Port projects is the difference between this flow and the existing pre-project 2-year, 7-day summer low streamflow described above, as determined from the modeled 1994 ("existing") land use conditions (0.33 cfs²). The difference between 1994 and 2006 flows is 0.08 cfs². This flow rate is the magnitude of offset that will be provided during the summer low-streamflow period for Des Moines Creek.

2.5.2 Summary of Water Level Impacts

If not mitigated, one impact of reduced streamflow during the summer low-rainfall season would be reduced water depth in the project area streams. To determine the estimated flow depth changes during low-flow periods before and after construction of Master Plan Update projects, a HEC-RAS model was prepared. Detailed HEC-RAS modeling information and associated field survey data are provided in Appendix E.

The HEC-RAS model was used to predict the water depth in the streams at different flow rates. Rating curves (flow rate versus flow depth) were developed for Miller, Walker, and Des Moines Creeks (Figures 2-2, 2-3, and 2-4). These curves were used to predict the water depth for flows before (1994) and after (2006) construction to determine the potential impacts to the stream from flow reduction during low-flow periods (if not mitigated).

The HEC-RAS model was developed using representative surveyed cross-sections from Miller, Walker, and Des Moines Creeks. The sections were repeated in the model at gradually higher elevations (moving downstream to upstream) corresponding to the measured stream profile. Downstream water depths were calculated by the model using the normal depth routine. Flow rates for each stream correspond to the general range of flows from the lowest modeled by the HSPF model to the greatest 7-day low flow during the period of rainfall record. Channel roughness was assumed to range from 0.025 to 0.035 based on observation of channel characteristics.

The estimated average change in water depths between the 1994 and 2006 2-year, 7-day low flows are summarized in Table 2-10. In addition, the corresponding estimated average change in stream widths between the 1994 and 2006 2-year, 7-day low flows are summarized in Table 2-10. The magnitude of these water depth and width changes are graphically illustrated, to scale, in Figure 2-5.

Table 2-10. Changes in average water depths and widths between the 1994 and 2006 2-year, 7-day low flows (not accounting for low flow mitigation).

Creek	Total Net Streamflow Impact (cfs)	Depth		Width	
		Average change (ft)	Average change (mm)	Average change (ft)	Average change (mm)
Miller	+0.01	+0.00	0	+0.02	+6
Walker	-0.11	-0.01	-3	-0.10	-30
Des Moines	-0.08	-0.03	-9	-0.33	-101

² Actual values are 0.334 (1994) and 0.257 (2006), for a difference of 0.077, which was rounded to 0.08.

Figure 2-2: Flow Rate Versus Depth Curve for Miller Creek

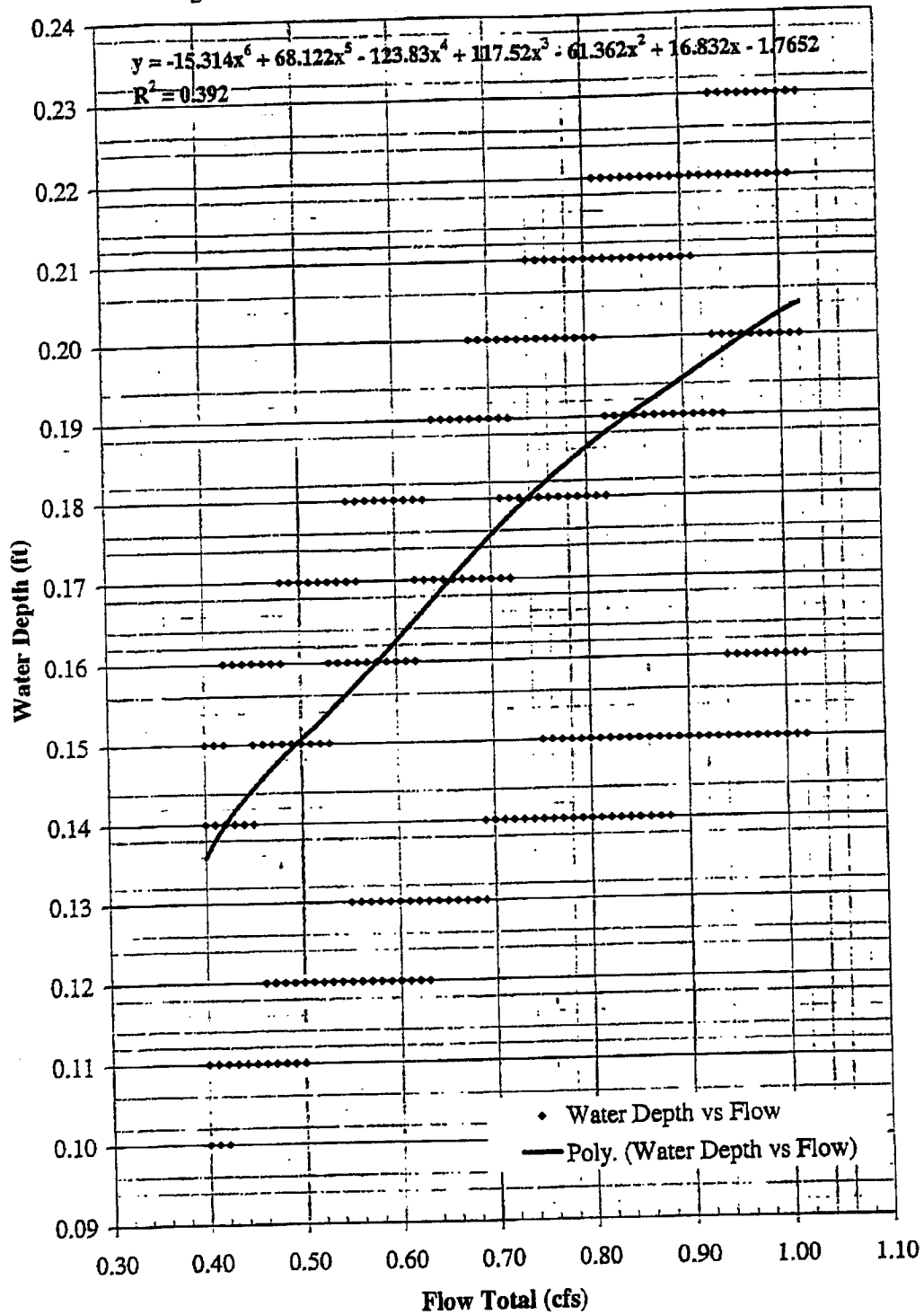

Figure 2-3: Flow Rate Versus Depth Curve for Walker Creek

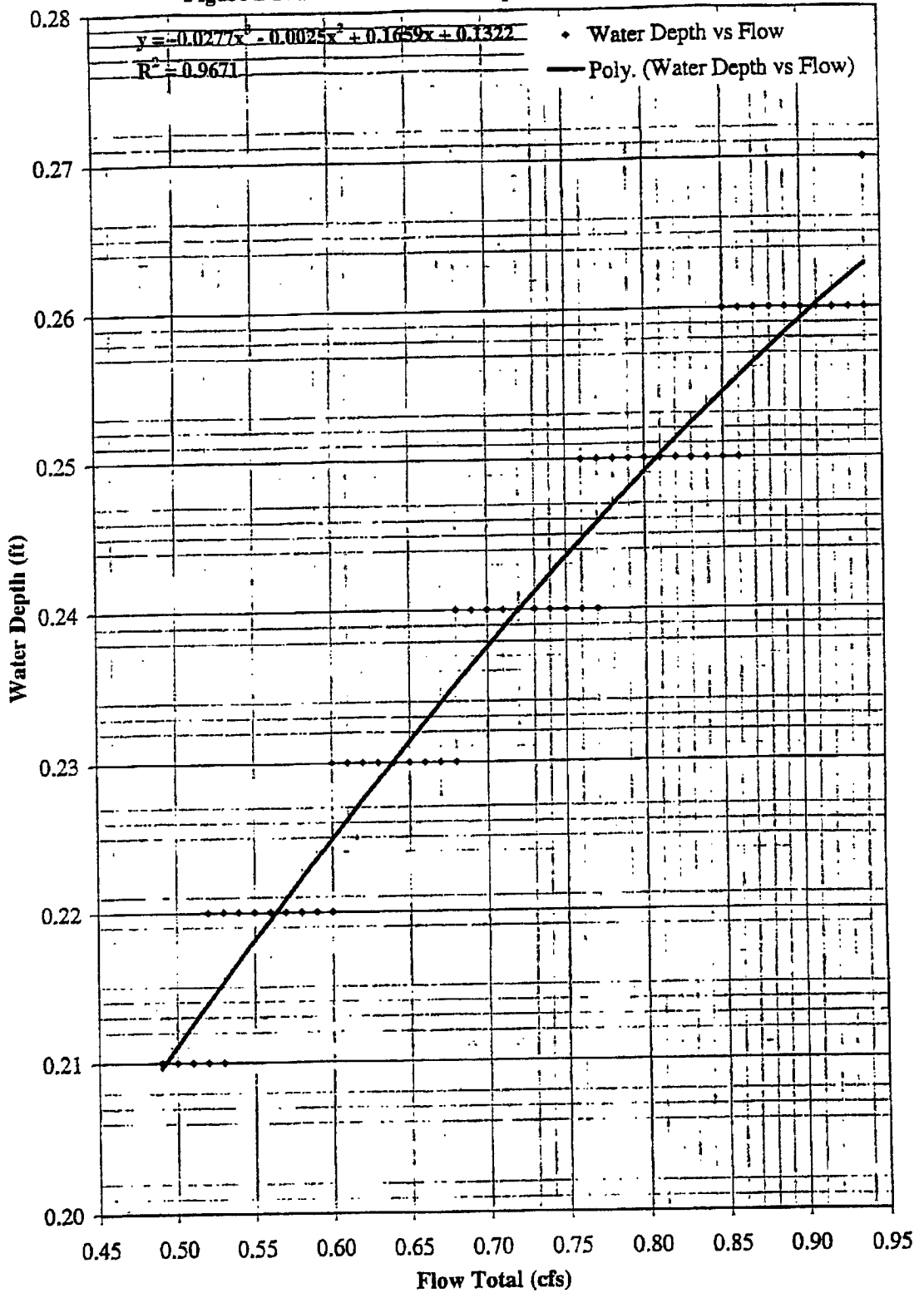
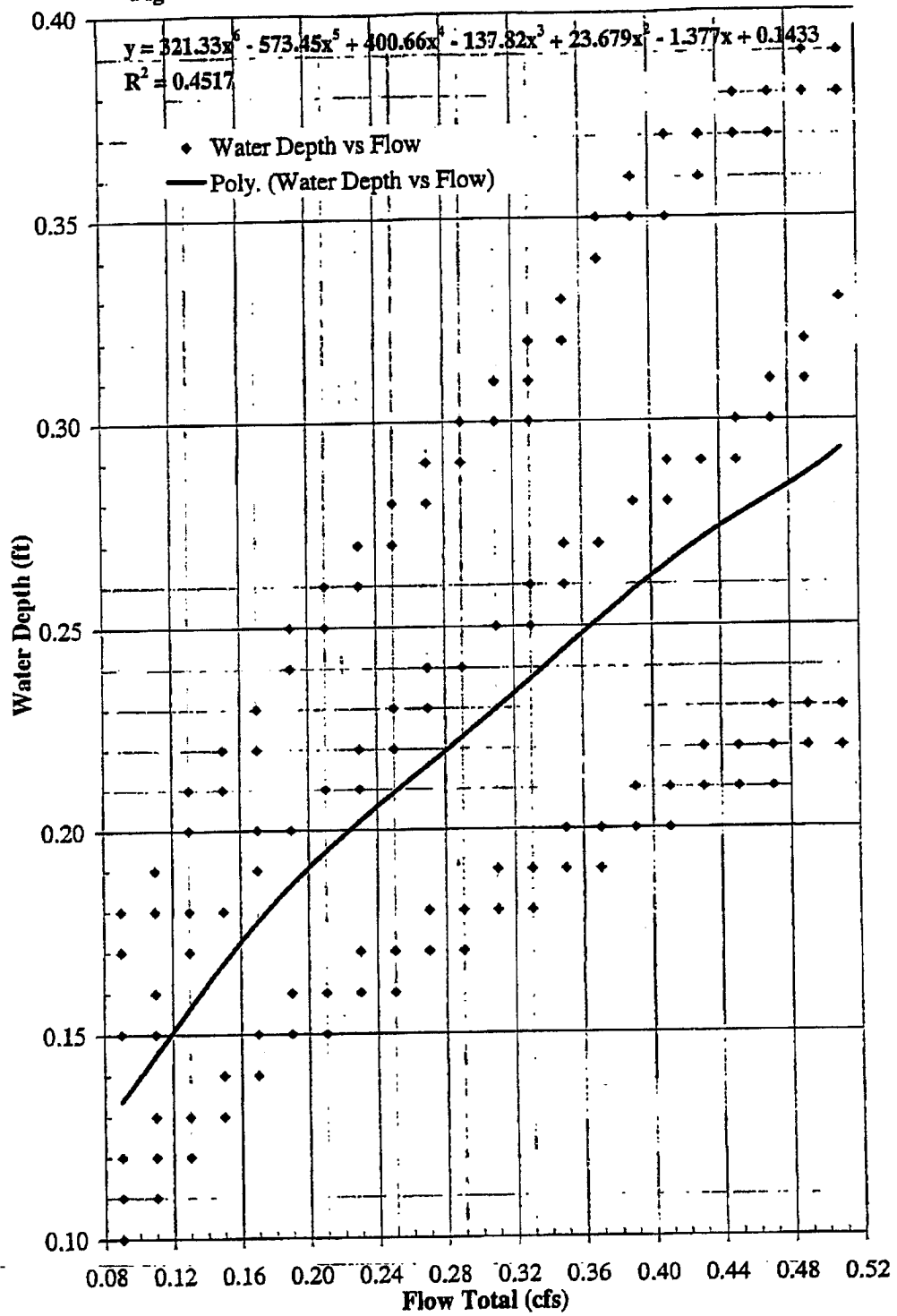

Figure 2-4: Flow Rate Versus Depth Curve for Des Moines Creek



Miller Creek

Change in Channel Low Flow Depth = 0.00 ft (0 mm)



Change in Channel Low Flow Width = +0.02 ft (+6 mm)

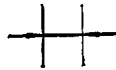

Walker Creek

Change in Channel Low Flow Depth = -0.01 ft (-3 mm)



Change in Channel Low Flow Width = -0.10 ft (-30 mm)



Des Moines Creek

Change in Channel Low Flow Depth = -0.03 ft (-9 mm)



Change in Channel Low Flow Width = -0.33 ft (-101 mm)



FILE: K:\CAD\2912\55291201\Task 28\Low flow impacts fig.dwg
DATE: 12/10/01

A scale bar with markings at 0, 0.5, and 1 inch.
DRAWING TO SCALE

Figure 2-5
Changes in Average Water Depths and Widths Between the 1994 and 2006 2-Year, 7-Day Low Flows (Not Accounting for Low-Flow Mitigation)

3. MITIGATION PROPOSAL

3.1 INTRODUCTION OF APPROACH

Hydrologic modeling of the airport drainage areas to determine the potential impacts of Master Plan Update projects, combined with the embankment modeling described in Section 1.3, demonstrate the magnitude of potential low-streamflow impacts due to the construction of Master Plan Update projects. To mitigate these impacts, the Port will collect excess runoff from impervious surfaces during winter storms and reserve that stormwater for discharge during the defined summer low-flow period. This mitigation plan includes the following components:

- Low-flow mitigation performance standards.
- Determination of the season and duration for low-flow mitigation.
- Sizing and location of storage vaults.
- Water quality design aspects.

The proposed mitigation plan is described in the following selections. In addition, a pilot program to test the efficacy of this mitigation approach is described in Section 3.6.

3.2 PERFORMANCE STANDARDS

The overall goal of the Flow Impact Offset Facility is to provide water to Walker and Des Moines Creeks at rates and times equal to the impacts to streamflows calculated by the low-flow analysis. The following measurable performance standards have been developed in order to facilitate meeting this goal:

- To fill the vaults during the rainy season according to the analysis provided in Section 3.3.
- To provide flow at the rates specified in Section 2.5.1 for the entire annual low-flow period each year for each stream (July 24 through October 24 in Des Moines Creek; August 1 through October 31 in Walker Creek).
- To provide flow for additional periods (throughout the month of November) using water remaining in the vaults at the end of the low-flow period.
- To operate the facility in a manner to prevent instream water quality violations caused by operation of the facility.
- To design, operate, and maintain the facility so an adaptive management strategy can be applied.

3.3 WATER QUANTITY – VAULT SIZING ANALYSIS

The vault sizing and vault fill time analyses are summarized below. Additional information and data are provided in Appendices I and J.

3.3.1 Vault Sizing

Vault size was determined by calculating the vault volume necessary to fulfill the required mitigation during the 92-day mitigation period for each stream for each year in the period of record from 1949 to 1995, and selecting the year requiring the largest vault volume as the 'worst case' scenario. The vault size equation returns a daily update of constant mitigation flow accumulation modified by any rainfall recharge. This calculation was repeated for each day in the mitigation period using the previous day's total as a starting point.

The HSPF hydrologic model was used to calculate the rainfall recharge volume generated by runoff from the impervious surface area tributary to the flow mitigation vaults. The intent of the simulation was to account for the reduction in runoff volume due to surface retention and evaporation effects. Flow routing also impacts the timing of the flow to the vaults. The hydrologic parameters, precipitation data, and evaporation data developed for the Des Moines Creek calibration model were used in the impervious surface runoff file. No pervious surfaces were simulated in the model. The HSPF vault sizing input file is included in Appendix J.

The mean, median, minimum, and maximum of the largest vault size necessary within a year were calculated from all years in the period of record from 1949 to 1995. The maximum value was used to determine the size of the storage facility necessary to fulfill the mitigation needs for each stream basin (Table 3-1).

Table 3-1. Summer low flow impact offset maximum vault sizes.

Basin	Vault Size (acre-ft)
Walker Creek	19.0 ^a
Des Moines Creek	13.5

^a Analysis determined 18.5 acre-ft; concept design used 19.0 acre-ft.

3.3.2 Vault Fill Time

The vault fill time calculation records the number of days required to fill a vault to the storage capacity needed on the first day of the mitigation period, for all years in the full record (1949 to 1995) using historical precipitation records and impervious surface areas. Fill time for storage vaults was calculated as the number of days required to fill an empty vault from its close date to the fill limit determined in the vault size calculations. Beginning on the close date and using the previous day's volume as a starting point (zero on the first day), runoff (as calculated by the HSPF recharge model, see Appendix J) was added to the vault. When runoff from storm events filled a vault to the maximum fill volume, the number of days necessary to reach that volume was recorded. The vaults in Des Moines and Walker Creeks were assumed to begin filling on January 2nd.

The mean, median, minimum, and maximum number of days were calculated from the number of days necessary to fill the vault in the period of record from 1949 to 1995 (Table 3-2).

Table 3-2. Low flow vault fill time estimates.

Basin	Estimated Vault Fill Time (days)			
	Mean	Median	Minimum	Maximum
Walker Creek	71	60	22	213
Des Moines Creek	11	8	1	38

3.4 WATER QUALITY DESIGN

3.4.1 Introduction

Ecology has defined standards for water quality related to stormwater release, including periods of low flow. Ecology has jurisdiction to monitor and enforce these standards through their National Pollution Discharge Elimination System (NPDES) Permit. These standards include turbidity, dissolved oxygen (DO), temperature, and dissolved metals. The Port's current stormwater design plans for the third runway construction include a stormwater system and operational procedures to provide the storage and managed release of stormwater during low-flow periods. These stormwater storage facilities employ biofiltration strips, catchbasins, detention pond, and vaults to meet current King County water quality requirements. In addition, the facilities are designed to be retrofitted according to the Ecology Stormwater Management Manual (Ecology 2001) if specific water quality concerns are identified during post-construction monitoring. The Port's monitoring and reporting program (see Section 5) is proposed to assess the performance of the facilities, allowing adaptive management to be used in the implementation of additional water quality measures to ensure that standards will continue to be met.

Des Moines, Miller, and Walker Creeks are all assumed to be Class AA (extraordinary) waters (WAC 173-201A-030). As such, the water quality standards discussed in this report are those listed for Class AA water bodies, which are the most stringent standards. Water quality standards for metals are based on toxicity, are independent of the receiving water classification, and are listed in WAC 173-201A-040 (Toxic Substances). Ecology has started the process to potentially revise state water quality standards. The Port will continue to evaluate the proposed changes as part of the final design process and make any needed changes to the facility.

The state water quality standards applicable to the managed release of stormwater to offset flow impacts are discussed below. Specific design features, assumptions, and other information considered in the design of the facility are included. Operational and monitoring proposals are presented in Sections 4 and 5 of this report. References to stormwater vaults refer only to those vaults proposed to detain stormwater to offset impacts to streamflows. Likewise, references to stormwater and stormwater discharges refer only to the managed release of stormwater to offset flow impacts.

All of the stormwater that will be released to offset the impacts during summer low-flow periods will be collected from new and existing airfield areas. The airfield is a highly managed controlled-access area, and generates stormwater that is generally cleaner than typical urban stormwater (Port of Seattle 2000a).

3.4.2 Turbidity

The state water quality standard for turbidity in class AA waters is a two-tiered standard. For receiving water with turbidity less than or equal to 50 NTU (background flow), discharged water may not increase the receiving waters more than 5 NTU over background. For receiving water with turbidity greater than 50 NTU, discharged water may not increase turbidity of the receiving waters more than 10 percent. Turbidity levels in the streams vary between less than 5 NTU to over 1,000 NTU. The lowest turbidity levels in the streams generally occur during low streamflow (base flow) conditions, which correspond to the majority of periods when the stormwater would be released to the streams to offset flow impacts. It is assumed that the releases of stormwater to offset flow impacts would have to meet the 5 NTU standard most, if not all, of the time. To minimize the need to provide constant background level monitoring of the stream above and below the release locations, releases will be limited to 5 NTU or less to ensure compliance at all times.

There are several operational considerations and water quality BMPs in place at the airport to reduce the sediment and turbidity levels in runoff water going into stormwater storage. The Port uses catchbasins, the Industrial Wastewater System (IWS), and biofiltration strips as BMPs on the existing airfield, and the SMP proposes to retrofit the existing airfield with additional sediment trap BMPs in the bottom of each new detention vault facility. The new airfield surface will incorporate similar BMPs to minimize the amount of sediment and suspended solids that could potentially get into the stormwater vaults. The primary BMP consists of the construction of biofiltration strips in the new and existing airfield areas that treat stormwater as it drains directly from impervious areas of runways and taxiways. The Port will also maintain catchbasins to ensure they continue to trap sediments. Filter strips are already in place in the existing Taxiway "C" airfield area that drains to the stormwater vault (SDS3A) located in the Des Moines Creek watershed (see Section 7 in the SMP). In addition, the airfield is a controlled area subject to very low levels of travel by ground vehicles and frequent cleaning and inspection for debris that could be harmful to aircraft. Consequently, the airfield is generally much cleaner than most urban areas that generate stormwater runoff.

There are also operational procedures outlined in the airport's Stormwater Pollution Prevention Plan (SWPPP) that will minimize opportunities for sediment and suspended solids to enter the stormwater vaults. These include:

- Sweeping ramp areas several times per week.
- Annual inspection of catchbasins and cleaning if the depth of sediment equals or exceeds one-third the depth from the bottom of the basin to the invert of the lowest pipe.
- Proper storage and disposal of sediment removed from catchbasins.
- Hydroblasting of runway skid-mark rubber. Water and removed rubber is vacuumed by the same machine, drained, and deposited at the decant station until disposed as solid waste.

All of these BMPs will limit the amount of sediments and suspended solids that enter the stormwater vaults, and therefore will reduce the turbidity of the water stored in the vaults and discharged to the streams.

All of the proposed stormwater vaults, including those associated with the Flow Impact Offset Facility, employ features designed to provide treatment (settling and removal) of suspended solids and turbidity. These features include:

- Dividing the dead storage area (similar to the areas in the vaults where the stormwater detained to offset flow impacts will be held) into several compartments by constructing short walls within the dead storage area of each vault. The compartments provide areas for suspended solids to settle out and be contained. Each compartment's outlet will be configured so that the suspended solids are captured in the compartments during low-flow release periods. Design considerations of this type are typically included in stormwater vaults. Details will be provided at final design of the stormwater vaults.
- The vaults will include an extra 6-inch depth for the first third of the bottom (minimum) to facilitate trapping sediment that reaches the vault.
- The inlets and outlets in the vaults will be configured to minimize disturbance of sediments and floatables within the vaults. This will be done by locating the inlets and outlets within the middle third of the reserved storage depth. Outlets will incorporate a floating design to accomplish this, as well as to maintain a consistent discharge rate.
- Maintenance of the vaults will remove and properly dispose of collected sediments outside of the anticipated low-flow release periods.
- The vaults will be designed to allow installation of additional water quality measures, if needed. Additional water quality features may include filtration of the discharges, oil/water separators, or aeration.

The design of the stormwater vaults, in combination with the operational and monitoring considerations discussed below, will ensure that release of stormwater will not cause violations in the turbidity standards. The Port is currently investigating filtration of stormwater associated with discharges from a landside drainage basin. This research includes determining the effectiveness of several filtration media in treating the stormwater. The results of this study will be completed before final design of the flow offset facilities, and the data will be used to select the filtration method most appropriate to treat the stormwater discharge, if needed.

3.4.3 Temperature

The state water quality standard for temperature in class AA waters is not to raise the temperature of the receiving water to over 16 degrees Celsius (°C). If the baseline temperature of the receiving water is greater than or equal to 16°C, then discharges cannot raise the temperature more than 0.3°C. To date, Ecology has not applied these requirements to stormwater discharges, although they have required temperature monitoring of certain stormwater discharges. Ecology could apply the temperature standard to future stormwater discharges.

The highest annual temperatures in the streams are usually reached during the summer months, which is the period when the Flow Impact Offset Facility is expected to be in operation. Solar radiation is the primary mechanism by which stormwater temperatures increase in detention ponds. Since the stormwater vaults are typically underground structures, there will generally be no direct

solar warming. Underground storage provides a constant temperature that will be lower than open storage facilities, more closely matching a native groundwater seep temperature. Water released from the Flow Impact Offset Facility is not expected to increase instream water temperatures. Since the proposed underground stormwater vaults will result in relatively cool water being discharged, no special design considerations are proposed to manage water temperatures in the vaults associated with the Flow Impact Offset Facility.

The Port has begun to collect water temperature data from existing stormwater vaults and in the streams in order to characterize the expected temperatures of the reserved stormwater discharges. Commencing in the summer of 2001, average daily water temperature data is being collected from the NEPL vault and the SDS3A vault located near the south end of the airfield. Data will be collected from June through October of each year from the dead storage area of each vault. These existing vaults were selected because they are similar in size to the proposed stormwater volumes associated with the Flow Impact Offset Facility. The NEPL vault is partially exposed to sunlight (on its west side and top), while the SDS3A vault is completely underground. By collecting temperature data from both vaults, a range of expected temperatures will be established. Temperature data will be collected from the dead storage zone in each vault in order to approximate the vaults associated with the Flow Impact Offset Facility. This data will be compared to stream temperature data also being collected by the Port to characterize any cooling effects of stormwater releases on water temperatures in the streams.

3.4.4 Dissolved Oxygen

The state water quality standard for DO in Class AA waters is 9.5 milligrams per liter (mg/l). Low DO levels in streams during summer low-flow periods is a potential water quality concern. The Flow Impact Offset Facility will be designed and operated in a manner that will not decrease the DO levels in the streams, and under typical conditions, may act to increase DO levels in the streams.

It is anticipated that DO levels in the stormwater vaults should not be significantly reduced while the water is stored. There should be little, if any, biological activity in the vaults that could consume oxygen as a result of the lack of sunlight and the low biological oxygen demand (BOD) typically seen in stormwater runoff from the airfield (Port of Seattle 2000a). The infrequent and short-lived episodes of elevated BOD due to runway de-icing activities are not expected to impact the DO concentrations of the stormwater detained in the Flow Impact Offset Facility because the stormwater associated with these events moves through the stormwater management system in a matter of hours, is replaced with runoff with the low BOD concentrations more typical of airport runoff (Port of Seattle 2000b), and typically happens during the winter months when reserved stormwater releases from the Flow Impact Offset Facility would not take place. In addition, the Port operates BMPs to move snow containing de-icing chemicals (a potential source of BOD) from the airfield to snowmelt areas that drain to the IWS, further reducing the BOD in water that drains to stormwater vaults.

Vents will be included in the stormwater vaults associated with the Flow Impact Offset Facility to allow for the circulation of fresh air. This will help maintain the dissolved oxygen concentration of the stormwater.

An additional design consideration is the positioning of the inlet(s) to the stormwater vaults associated with the Flow Impact Offset Facility. The inlet(s) will be placed as low as possible in the

vault (consistent with the inlet placement parameters in the turbidity section above) in order to facilitate flushing of the vault each time there is sufficient rainfall to generate stormwater runoff. Typically, stormwater inlets in vaults are placed at higher elevations within the vault. As a result, water in the lower or dead storage areas may not be circulated and may stagnate. By placing the inlet at a lower elevation, water already in the lower portions of the vault will be displaced by the incoming water and will not have the opportunity to stagnate. Continually replacing the water in the stormwater vaults should benefit the DO levels in the stormwater. Each stormwater vault associated with the Flow Impact Offset Facility will have its inlet position carefully considered during the final design phase, and placed to enhance this circulating effect as much as possible consistent with other requirements.

Passive aeration of stormwater can be achieved through natural turbulence or agitation of the discharges. Steeply sloped pipes with periodic drop structures will be required to move the water from the vault outlets to the stream elevation. An energy-dissipating structure will be required near the release point at stream level to slow the velocity adequately for entering the stream safely, without causing scour or erosion. Both the steeply sloped discharge pipes and the energy-dissipating structures will provide the turbulence or agitation needed to provide passive aeration. Where insufficient fall is available for this natural aeration process, the installation and operation of aeration devices may be necessary. Other vaults are located near the level of the stream discharge elevation such that active aeration measures may be required through the installation of some type of aeration device. Active aeration systems that could be utilized include microbubble diffusers, gas injection, air injection, mechanical aerators, or aeration hoses. Microbubble diffusers consist of a porous ceramic plate (similar to aquarium aeration stones) and a pump to inject air through the plate. Gas and air injection systems inject a controlled amount of gas or air under pressure into the discharge water pipe. Mechanical aerators physically agitate water and allow air to become mixed with the water. Aeration hoses are flexible porous rubber hoses that have air pumped through them similar to the microbubble diffusers. Information on each of these devices is included in Appendix F. Although the selection of the device(s) to be installed will be made during the final design of the Flow Impact Offset Facility, it is likely that the microbubble diffuser will be selected and installed because of its simplicity, effectiveness, cost, and ability to be installed in the discharge pipes. Other attractive features of the microbubble diffuser include low maintenance requirements, the use of a small compressor or pump to provide air instead of the use of compressed gas tanks, and the ability to be automated to function anytime the reserved stormwater discharge valve is open.

3.4.5 Nutrients

There are no water quality standards for nutrients in the current water quality standards. However, nutrients typically found in urban stormwater could be of potential concern. If nutrient-rich stormwater is stored for long periods, exposure to solar radiation can potentially cause algae blooms. However, it is expected that there will be no adverse water quality impacts associated with nutrients in the release of reserved stormwater for the following reasons:

- There is no significant source of nutrients associated with the airfield areas identified as sources of water for the Flow Impact Offset Facility. Primary sources for nutrients in urban stormwater are fertilizers applied to lawns and landscaped areas. However, the grass infield areas of the airfield are not fertilized or irrigated because lush growth could become a wildlife attractant concern. Any landscaped areas to which fertilizers are applied are located near the terminal and drain to stormwater basins that do not contribute flow to the Flow

Impact Offset Facility. The Port's use of fertilizers includes applying the BMPs listed in the airport's SWPPP, which further reduces the amount of fertilizers and nutrients that enter stormwater. With careful management of fertilizer use at the airport, there is no major source of nutrients for the drainage areas that contribute stormwater to the Flow Impact Offset Facility.

- The operation of BMPs on the airfield (biofiltration swales) would reduce the opportunity and concentrations of any nutrients that exist prior to the stormwater entering the vaults.
- Since the vaults are underground facilities, there is no sunlight that would stimulate the growth of algae often associated with elevated nutrient levels.
- Instream residence time for the stormwater discharged from the Flow Impact Offset Facility is only a matter of hours (the time it takes water to flow from the discharge points in the airport vicinity to the streams' discharge points in Puget Sound). Therefore, there will be minimal opportunity for biological activity (algae blooms) in the streams. Such water quality impacts from nutrients are typically associated with lakes and ponds, where long residence time would provide the opportunity for excess algae growth to occur. Since no lakes or ponds occur in the streams between the airport and Puget Sound, this is not an issue.

Given the above, the Port does not propose any monitoring for nutrients in the discharges from the Flow Impact Offset Facility. Through continued implementation of the SWPPP, the BMPs currently in place that manage the use of fertilizers will continue to minimize the opportunities for nutrients to enter stormwater runoff.

3.4.6 Metals

Metals of concern include copper, lead, and zinc. Washington State water quality standards for these metals are based on the dissolved fraction, are dependent on the hardness of the water, and, as with all water quality standards, are applicable to the receiving waters. Chemistry data from existing airfield stormwater discharges (which are typical of the stormwater that would be reserved for release during low-flow periods) have been reported in the annual stormwater monitoring reports. Metal concentrations in these discharges are reported as total recoverable metals, which are not directly comparable to the dissolved fraction listed in the water quality standards. However, this data does serve as an indication of metal concentrations to be expected in the discharges of stormwater from the Flow Impact Offset Facility. Median metals concentrations from airfield stormwater typically range from 0.012 to 0.031 mg/l copper, 0.001 to 0.003 mg/l lead, and 0.020 to 0.051 mg/l zinc (Port of Seattle 2001b). These values were obtained for stormwater sampled at points prior to entering the receiving waters. Additional treatment that occurs in surface waterways prior to entering the receiving waters will result in lower metals concentrations actually entering the streams. In general, these metal concentrations are also less than typical urban runoff, as discussed in the Port's annual stormwater monitoring reports (Port of Seattle 2000a, 2001b). In addition, the Port has conducted whole effluent toxicity testing of stormwater discharges, as required by its NPDES permit (see discussions in the annual monitoring reports). Stormwater associated with airfield subbasins met the performance standards for whole effluent toxicity according to Ecology guidelines. All this information indicates that the Flow Impact Offset Facility can be managed to meet the water quality standards for metals in the receiving waters.

The following items should be considered in the management of the Flow Impact Offset Facility for compliance with state water quality standards:

- A large portion of metals in urban stormwater is attributed to motor vehicle activity. This is illustrated in the annual stormwater monitoring reports, which show higher metal concentrations are associated with the landside basins where motor vehicle activity is concentrated. Since access to the airfield is strictly controlled, motor vehicle activity is kept to a minimum. Therefore, metal concentrations in stormwater runoff are minimized. The airfield basins are the areas that will be providing stormwater to the Flow Impact Offset Facility, and these areas typically have the lowest lead and zinc concentrations of all airport stormwater discharges (copper concentrations are more consistent in all airport stormwater discharges, but are still relatively low in airfield stormwater).
- Data collected by the Port show that a large fraction of the metal concentrations are associated with particulates (i.e., the metal ions are bound to particulate matter). Therefore, the design and management practices proposed to minimize or reduce particulates and turbidity will also reduce total metal concentrations in the stormwater discharges. Biofiltration swales, settling in vaults, and (additional) filtration are all effective in reducing particulates, and therefore total metal concentrations will be reduced as well. Although these BMPs may not be effective in removing dissolved metals, the majority of the metals are bound to particulates and will be removed. The design features proposed for the reserved stormwater vaults (compartmentalized storage, sloping the vault floor away from the stormwater outlets, careful placement of the stormwater inlets and outlets, and the provision for installation of filters) will ensure that the discharge of sediments and metals bound to particles will be minimized.
- The Port is currently investigating filtration of stormwater associated with discharges from a landside basin. This research includes determining the effectiveness of several filtration media in treating the stormwater. The results of this study will be completed before final design of the flow offset facilities, and the data will be used to select the filtration method most appropriate to treat the discharge from the Flow Impact Offset Facility, if needed.

3.5 ADDITIONAL INFORMATION

There are several other considerations relating to the design and operation of the Flow Impact Offset Facility, including the following items:

- The discharge points for the Flow Impact Offset Facility will be the same as the typical ("live") discharge point for each vault or pond they are associated with. This eliminates the need to permit and construct additional discharge points to the streams. The proposed location of each stormwater discharge point for the Flow Impact Offset Facility is illustrated in the drawings in Appendix F.
- All stormwater management facilities, including those associated with the Flow Impact Offset Facility, will be located within the airport's perimeter fencing, thereby controlling access to the facilities and reducing the potential for damage to the facilities from vandalism.

- The Port will operate, inspect, monitor, and maintain the Flow Impact Offset Facility as long as there is an airport at the site. In addition, the Port will provide annual monitoring reports to ensure that the Flow Impact Offset Facility is meeting its performance goals. An adaptive management method will be used to allow for needed adjustments in the operation of the facilities, and to allow for the installation of new management/monitoring technology, if needed.
- As stated in Ecology's *Stormwater Management Manual for Western Washington* (Ecology 2001), the objective of stormwater management is to "control the quantity and quality of stormwater produced by new development and redevelopment such that they comply with water quality standards and contribute to the protection of beneficial uses of the receiving waters." Ecology has determined that stormwater management activities in Washington State do not require a water right. Since the Port's proposal to offset flow impacts to the receiving waters consists of stormwater management activities, a water right is not required for the Flow Impact Offset Facility.
- The Port is incorporating BMPs into the embankment design to ensure infiltration into the embankment rather than the embankment conveyance system. These BMPs include the use of flatter than normal slopes in biofiltration swales, the use of materials (soils) with good infiltration capacities, the incorporation of soil amendments to increase infiltration, managing vegetation to enhance infiltration, and scarifying surfaces to eliminate barriers to infiltration.
- The Port has investigated the potential for conveyance losses to seepage between the discharge points of the reserved vaults and the streams. The portion of conveyance that occurs in unlined ditches or swales occurs in close proximity to the streams, so that any seepage to shallow groundwater is expected to discharge to the streams in a very short time, thereby not impacting the amount of water delivered to the streams. The proposed water quantity monitoring program will provide data to assess this performance characteristic. If losses are detected that are impacting the quantity of water delivered to the streams, actions will be taken to correct the situation, such as conveying the water in pipes to a point where losses will not occur.
- The Port is currently assessing the ability to route the discharges from the Flow Impact Offset Facility into wetlands that are hydraulically connected to the streams. This will be implemented wherever possible in the final design of each reserved stormwater vault. Note that if this is implemented, it may require the construction of additional discharge points (i.e., the reserved stormwater discharge point may have to be separate from the normal ("live") stormwater discharge point to achieve this goal). Analyses indicate that the groundwater hydrology of wetlands hydraulically connected to the streams will be maintained (Parametrix 2001b). To determine if hydrologic conditions in the wetlands are sufficient to maintain the existing vegetation types, the groundwater hydrology of the riparian wetlands adjacent to the Master Plan Update improvements will be monitored for up to 15 years as described in the *Natural Resource Mitigation Plan* (Parametrix 2000b).

3.6 PILOT PROGRAM PROPOSAL

Section I. a) ix) of the Department of Ecology's Water Quality Certification #1996-4-02325 states:

"The Port shall develop a pilot program to test one reserve stormwater vault for performance. The Port shall include a proposal for a pilot in the revised plan. The pilot shall be completed within three years after receipt of the Section 404 permit from the U. S. Army Corps of Engineers."

The Port proposes to modify the existing "taxiway" vault (SDS3A) in the Des Moines Creek drainage basin as the pilot program for the Flow Impact Offset Facility. The SDS3A vault was selected because most of the vaults proposed as part of the Flow Impact Offset Facility may not be constructed within the time period required in the Water Quality Certification. The SDS3A vault already exists, and can be easily reconfigured to include a reserved stormwater release function. Modification of the discharge structure and the addition of a separate reserved stormwater discharge line would be required.

Because the SDS3A vault already exists, it does not include several of the water quality design features of the proposed vaults, such as ventilation and optimal placement of stormwater inlets. However, this presents the opportunity to utilize the SDS3A vault as a baseline study, i.e., the water quality of the reserved discharge can be tested without the benefit of any of the proposed special design features. If data collected during operation of the pilot program indicates potential water quality problems, then the vault would be reconfigured to include the appropriate features, and additional data would be collected to measure the effectiveness of the features. Examples include:

- The SDS3A vault does not have any special ventilation features to enhance dissolved oxygen (DO) levels of the stored stormwater. Baseline information on DO within the vault and reserved discharges as they enter the stream would be collected. If DO levels are low, additional aeration features (both passive and active) can be added and their effectiveness measured through additional monitoring. The knowledge gained could then be applied to the proposed vaults.
- The SDS3A vault collects stormwater from the airfield (controlled vehicle access area), and employs typical sediment control BMPs (biofiltration swales, settling within the vault). Baseline information on the turbidity of reserved stormwater discharges would be collected, and modification to the vault would be made if turbidity problems are detected. Modifications could include reconfiguring the reserved storage area within the vault to increase its sediment trapping capability, reconfiguring inlets/outlets, or filtration. The effectiveness of these additional features would be measured, and knowledge gained could then be applied to the proposed vaults.

The SDS3A vault will be reconfigured to test the reserved stormwater release concept so that one full year of operational testing and monitoring will be completed within the time period set forth in Section I. a) ix) of the Department of Ecology's Water Quality Certification. After one full year of operation and monitoring, the Port will develop a report describing the operation and its performance. The report will be submitted to Ecology for review. If the SDS3A vault pilot program does not meet any of the performance standards listed in Section 3.2, the report will include an analysis and recommendations to increase performance to the required levels. These recommendations will be implemented in all of the reserved storage vaults, as appropriate.

4. OPERATION AND MAINTENANCE PLAN

4.1 PURPOSE AND SCOPE

4.1.1 Purpose of Plan

The low-flow impact offset vaults were designed to provide long-term detention of runoff for slow release during the summer low-flow period. The purpose of this Operation and Maintenance Plan is to set forth the procedures and schedules that Port maintenance staff will use for operating, inspecting, and maintaining the low-flow vaults. These procedures will be necessary to ensure that stored runoff water is available in adequate quantity and quality for release to the streams during summer low-flow conditions. A well-implemented operations and maintenance plan will also help the Port minimize long-term life cycle costs for the facilities.

4.1.2 Scope of Plan

The Operation and Maintenance Plan addresses the Low Flow Impact Offset Facilities listed below for Walker Creek (SDW2) and Des Moines Creek (SDS3). Detailed design information for each of these vaults is provided in Section 4.2. Facility operation information is contained in Section 4.3. Section 4.4 describes procedures for Port staff to periodically inspect the vaults and examine certain components and potential conditions, such as the accumulation of sediment and debris, clogging of pipes, or structural damage. Section 4.5 provides safety procedures that will be used by Port staff during vault operation, inspection, and maintenance activities.

4.2 FACILITY DESCRIPTIONS

The operation, site layout, and design features of the low-flow vaults are provided below. This information is intended to provide background information to Port staff regarding the operation and maintenance of these facilities.

4.2.1 Facility Design and Operation Concept

Underground vaults will be used to detain stormwater for reserve discharge during the summer low-flow period. Low-flow mitigation storage will be created in vaults adjacent to the SMP detention vaults. Water for low-flow mitigation storage will be captured and stored during the January through July period and released slowly during August through November (see Section 4.3, Facility Operation). In addition to flow control, the vaults will also include water quality treatment components (e.g., trash racks, oil-water separators, filters, etc.), as appropriate for the activities within the areas contributing stormwater to each vault.

4.2.2 Facilities Overview

A total of two low-flow vaults will be used. Locations of the vaults on the airport site are shown in Figure 4-1. Table 4-1 provides a list of the vaults and summarizes their major characteristics,

including facility layout and access, hydraulic features, and water quality control and treatment features. Concept drawings of each facility are provided in Appendix F.

4.3 FACILITY OPERATION

4.3.1 System Schedules

The overall operating schedules for the Walker and Des Moines Creek low-flow vaults are shown in Table 4-2 and in Figures 4-2 and 4-3. The fill rate (water storage) is shown in the figures as linear, but in practice the fill rate is expected to be highly variable depending on the specific vault design, capacity, and rainfall patterns.

If any water remains in the vaults at the end of the summer low-flow period (end of October), the Port shall continue to release the water at the existing rate until the vaults are empty, or until rainfalls occur that cause a significant increase in the base flows of the streams.

Table 4-1. Summary of Low Flow Impact Offset Facilities.

	SDW2	SDS3
General description		
Location	West central side of new runway	North of South 188th Street
System	Walker Creek	Des Moines Creek
Drawing number	C 131	C 141
Type	Underground, rectangular, concrete, single-compartment vault with high-level bypass pipe adjacent to pond F	Underground, rectangular, concrete, with two compartments: low-flow storage and short-term detention
Plan dimensions	Approximately 442 ft x 250 ft	Low-flow storage compartment, approximately 126 ft x 700 ft
Access	Approximately 40 10x10-ft access grates; 1 down ramp	Approximately 6 main access lids
Low-flow offset storage		
Type	Vault dedicated to low-flow offset storage	Low-flow storage compartment as part of overall structure
Volume	19.0 acre-ft ^a	13.5 acre-ft
Maximum water depth	8.0 ft	7.2 ft
Hydraulic features		
Inlet structure	Pipe from MH SDW2-9	Pipe from MH SDS3-592
Outlet structure	Low-level outlet pipe	Low-level outlet pipe
Outlet control	Valve	Valve
Outlet conveyance	Approximate 700-ft pipe	Pipe to MH SDS3-197
Discharge to stream	Adjacent to pond F outfall	SDS3 outfall
Water quality features		
Sediment trap	Sloped vault floor with internal dividing walls	Sloped vault floor with internal dividing walls
Aeration	Passive air flow through grates	Passive air flow through grates
Trash racks	(detail for construction)	(detail for construction)
Filters	Optional sand or filter media filter	Optional sand or filter media filter
Oil-water separators	(detail for construction)	(detail for construction)
Mechanical and Electrical		
Monitoring and alarms	(detail for construction)	(detail for construction)
Lighting	(detail for construction)	(detail for construction)
Washdown	(detail for construction)	(detail for construction)

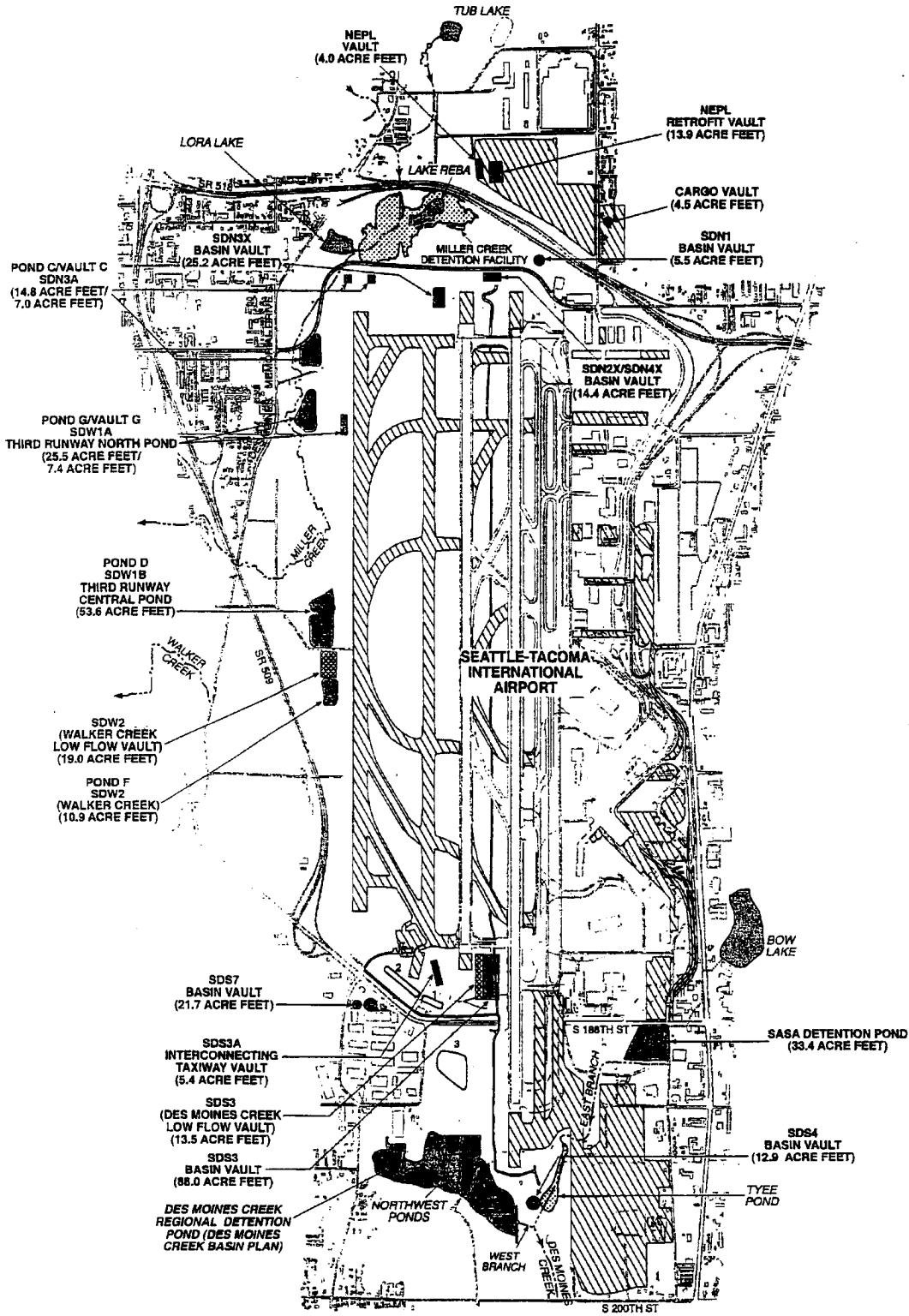

^a Analysis determined 18.5 acre-ft; concept design used 19.0 acre-ft.

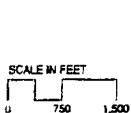

See-Tac Airport Stormwater Management Plan 666-2512-001(01)(200) 1201 (R)

AR 019939



-  Water Features
-  Proposed Stormwater Detention Facilities (With Stimulated Maximum Storage Volume)
-  Master Plan Projects



-  Creek
-  Piped Creek
-  Detention Facility
-  Low Flow Offset Facility

Figure 4-1
Low Flow Offset
Facilities Locations

**Figure 4-2
Walker Creek Facilities – Annual Schedule**

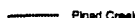

**Figure 4-3
Des Moines Creek Facilities – Annual Schedule**

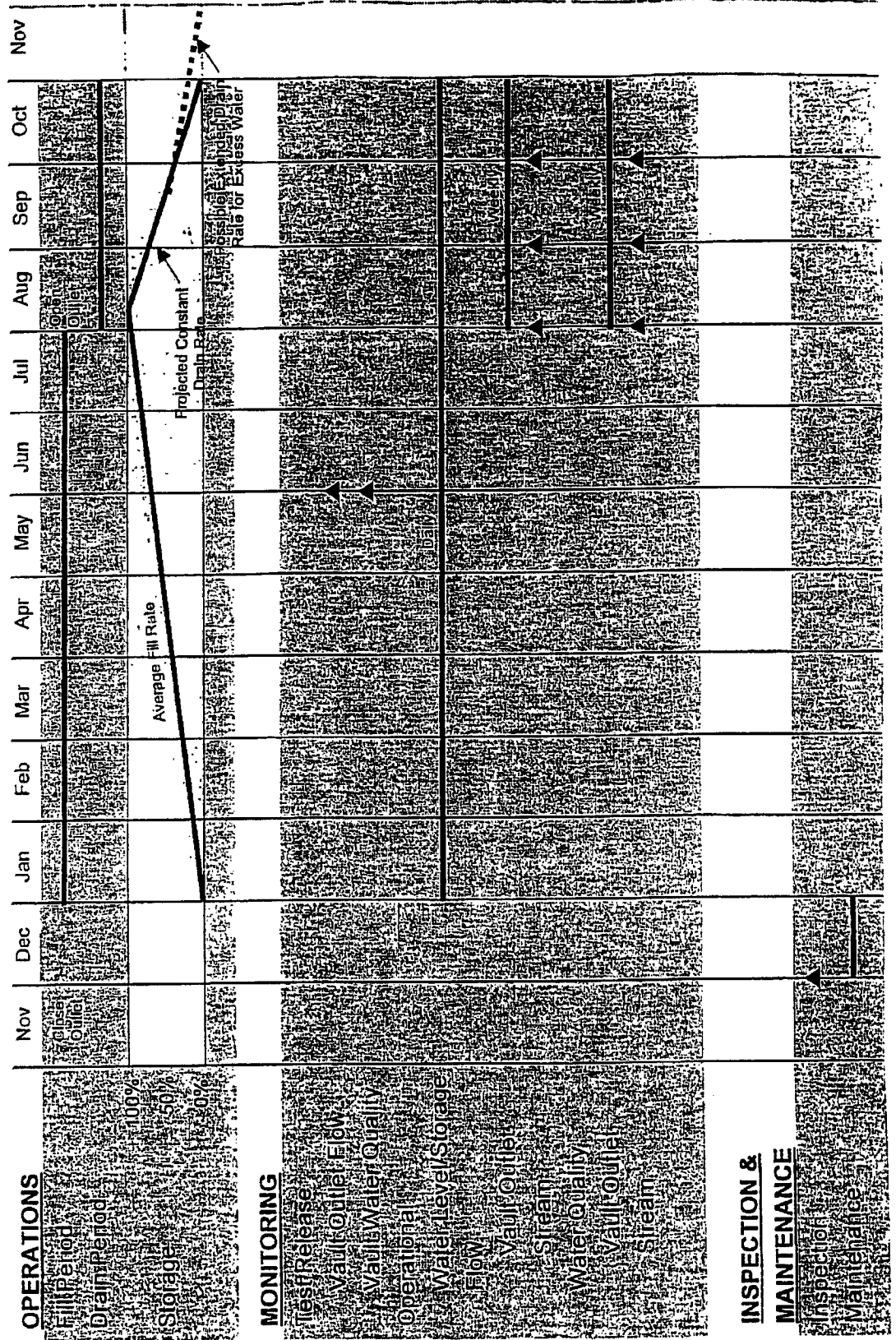
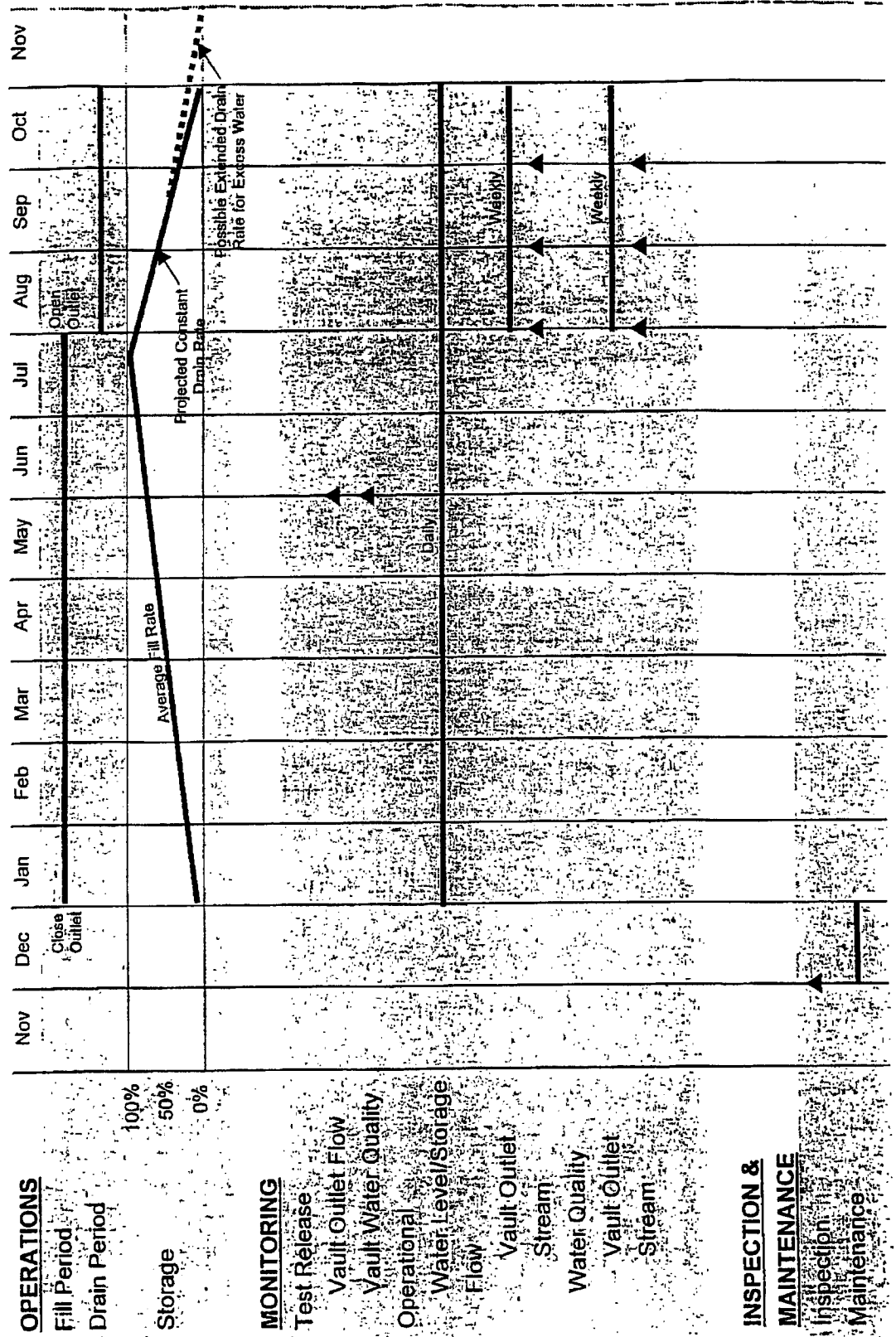

Table 4-2. Summary of Low-Flow Vaults Operating Schedules

	Walker Creek	Des Moines Creek
Start Vault Filling	January 2	January 2
Open Outlet/Start Vault Draining	August 1	July 24
Summer Low-Flow Period Ends	October 31	October 24
Summer Low-Flow Period Release Rate	0.11 cfs	0.08 cfs

4.3.2 Facility-Specific Schedules

As operating experience is gained by the Port, the fill and release schedules for the vaults may be adjusted to allow for more effective system operation. Facility-specific schedules will be added to this Operation and Maintenance Plan as they are developed in the future.

4.4 INSPECTION AND MAINTENANCE

The objective of the inspection and maintenance program is to ensure the reliability and consistent performance of the Low Flow Impact Offset Facilities in providing water in sufficient quantity and quality to the streams. In addition, the program will help to extend the life of the facilities and reduce the overall life-cycle costs to the Port.

4.4.1 Procedures

Figure 4-4 conceptually illustrates the inspection and maintenance program. The sample form shown in Figure 4-5 lists typical vault components that will be inspected. An inspection and maintenance record form that is specific to each facility will be developed as final designs are completed.

Inspectors will evaluate their observations with standards to determine if maintenance is required. In many situations, it is expected that maintenance will be performed at the time of inspection. In other situations, when additional staff or equipment is necessary, a work order request will be prepared and the maintenance will be performed at a later date.

4.4.2 Sediment Removal

Sediment is expected to accumulate in the bottom of the facilities below the low-flow outlet. Oil, grease, and other types of debris may also accumulate with the sediment. Regular and proper removal of sediment and debris is critical to ensure that water stored in the vaults will be of satisfactory quality when it is discharged to the streams.

Depending on the facility's design and the quantity of sediment that has accumulated, sediment will be removed with vector trucks, small front loaders, or manual tools. Washdown water may also be required. Regardless of the methods used, the low-flow outlet will be closed during the sediment removal process to prevent contaminated water from being discharged to the streams. The Port's existing decant facility shall be used for the disposal of all sediment and associated water that is removed from the vault during the sediment removal process.

Figure 4-4
Inspection and Maintenance Process Overview

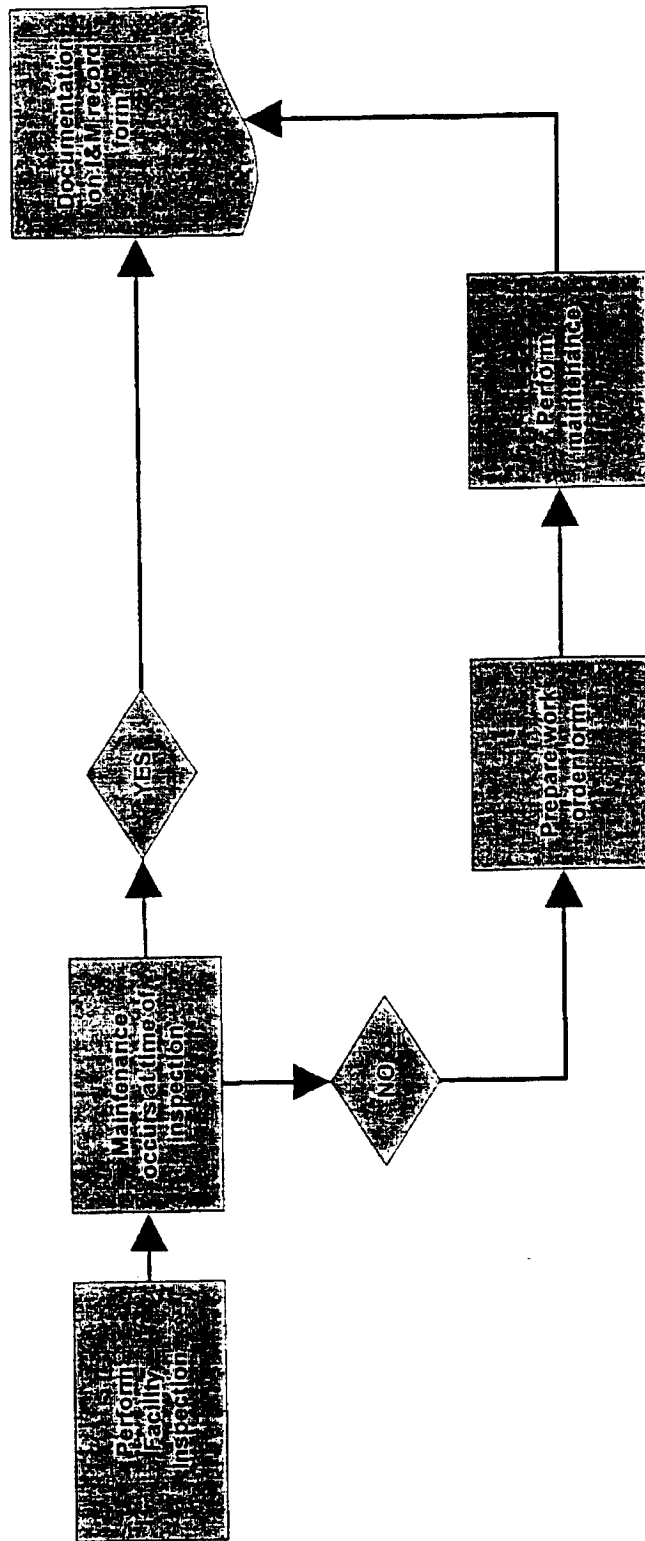

**Figure 4-5
Inspection and Maintenance Record**

Facility: _____
Inspection Date: _____
Inspector: _____

Facility Component	Inspection		Maintenance	
	Observed Condition	Required Maintenance	Performed By	Date
Access				
Hatches				
Ladders				
Ramps				
Vents				
Hydraulics and Controls				
Outlet pipe				
Outlet valve				
Weir				
Water Quality Treatment				
Trash racks				
Filters				
Oil-water separators				
Sediment Level				
Electrical / Mechanical				
Lights				
Water level instrumentation				
Internal piping				

4.4.3 Schedule

Vault facilities are projected to contain water in varying amounts during the period from January through October for low-flow mitigation purposes. Therefore, in order to conduct inspection and maintenance activities in-the-dry, this work will need to occur during November and December of each year. Specifically, as shown by the schedules in Figures 4-2 and 4-3, inspections will be performed in early November, followed by maintenance activities as necessary through December.

4.4.4 Documentation

An inspection and maintenance record form shall be completed for each inspection at each vault facility.

4.4.5 Reporting

Inspection and maintenance activities shall be summarized in the Port's annual report to Ecology.

4.5 SAFETY

Accumulated sediment, stagnant water conditions, and limited ventilation are typical conditions in vaults and may cause noxious gases to form and accumulate in the vaults. Additional ventilation will be provided in the low-flow vaults. Vault inspection and maintenance procedures must be in compliance with OSHA confined-space entry requirements, which includes clearly marking entrances to confined-space areas.

5. MONITORING PLAN

5.1 WATER QUALITY AND FLOW MONITORING

The Port is proposing a comprehensive monitoring plan for the Flow Impact Offset Facility to ensure that the performance standards are met and that no violations of state water quality standards occur in the receiving waters, and to support an adaptive management strategy. Monitoring consists of three elements: characterization of existing/expected water quality, monitoring of annual test releases from the Flow Impact Offset Facility, and monitoring of the discharges and receiving waters during operation of the facility. Each element is discussed below.

5.1.1 Characterization of Existing/Expected Water Quality

A great deal of water quality data already exists on the Port's stormwater discharges and on the streams. This data has been collected for a variety of purposes, including satisfying the Port's NPDES permit requirements, basin planning activities, and other studies done in the area by the Port and others. The data set includes water quality measurements within the stream systems during the summer periods when the Flow Impact Offset Facility will be scheduled to discharge to the streams. In addition, the Port has started to collect data to characterize the discharges from the Flow Impact Offset Facility. Temperature data is being collected starting in 2001 from the existing NEPL vault and the SDS3A vault in order to characterize the expected temperatures of the Flow Impact Offset Facility. The NEPL vault is partially exposed to sunlight (on its west side and top), while the SDS3A vault is completely underground. By collecting temperature data from both vaults, a range of expected temperatures can be established for each type of vault (buried and partially exposed). Temperature data will be collected from the dead storage zone in each vault in order to approximate the Flow Impact Offset Facility. The Port has collected some instream temperature data beginning in September 2000. Other data that is being collected as part of other Port water quality studies will be used prior to the operation of the Flow Impact Offset Facility to characterize expected water quality within the streams during the summer months (when the facility will be discharging). All of this data will be analyzed and presented in the final design of the facilities associated with the Flow Impact Offset Facility.

5.1.2 Monitoring of Annual Test Releases from the Flow Impact Offset Facility

Each year, prior to the operation of the Flow Impact Offset Facility, the Port proposes to conduct small test discharges from each outlet. The test discharges are intended to confirm the operation of each discharge and to detect and respond to potential problems prior to the annual operation of the Flow Impact Offset Facility. For example, because of the small orifices needed to control discharges to the required rate, a small amount of debris in an orifice could potentially impact the discharge rates. The discharge structures are being designed as floatable structures to maintain a constant discharge rate and minimize the potential to clog with debris or sediment (see Appendix F). Floating debris would be removed at this time to prevent impacts to the annual operation of the facility. Any other problems that may occur within the facility would be detected and corrected at this time.

Water quality sampling of small-volume test discharges is proposed. By conducting this sampling, potential water quality problems can be detected and corrective measures taken prior to scheduled annual releases to the stream systems. Water quality data obtained from the test discharges will be compared to the stream characterization data to determine the potential for water quality violations. If any are indicated, the Port will take corrective action prior to the annual operation of the facility, such as installing portable aerators or additional filtration in the discharges prior to their entry into the streams.

Wherever possible, the Port will install automated dataloggers and/or autosamplers to collect flow data and water quality samples. This will allow the monitoring plan to be flexible if it is determined that samples or data need to be collected more or less frequently than proposed at this time. In addition, it may become possible to automate the operation of the Flow Impact Offset Facility. Valves can be automated to close or open based on signals from dataloggers, and other logic can be programmed into an electronic management system (for example, the valve can be programmed to open only during the low-streamflow period). These systems will be evaluated during final design of the facility.

Water quality sampling of the test discharges will include the following:

- Flow
- Turbidity
- Dissolved Oxygen (DO)
- Temperature
- Metals

5.1.3 Operational Monitoring

The Port is proposing to monitor the operation of the Flow Impact Offset Facility to provide assurance that the facility is achieving its performance goals and not causing any water quality violations in the receiving waters. This will be accomplished by periodic monitoring of both the discharge and receiving waters during the annual operation of the facility, both while the vaults are being filled during the rainy season and while the vaults are discharging through the reserved stormwater outlets. The monitoring proposal for the Flow Impact Offset Facility includes the following monitoring components: water levels within the stormwater vaults, flow, turbidity, DO, temperature, and metals. Additional information on these components is provided below.

5.1.3.1 Water Levels

Water levels within the stormwater vaults will be monitored through installation and operation of a pressure transducer and datalogger in each vault. Average daily water levels will be calculated based on more frequent measurements by the pressure transducer/logger. This data will then be applied to the vault geometry to calculate the volume of water in the stormwater vaults. In addition, vault filling and emptying (average daily water levels) will be monitored throughout the year.

5.1.3.2 Flow

Discharge from each vault will be measured upon opening of the Flow Impact Offset Facility outlets and measured a minimum of weekly throughout annual operation of the facility. In addition, stream gage data will be collected from the King County gages currently active in the Miller, Walker, and Des Moines Creek watersheds in the airport facility and downstream to the mouth of each stream. The Port will coordinate with King County to ensure that data from these gages will continue to be collected in the future.

5.1.3.3 Turbidity

Turbidity data will be taken at discharge points, upstream in receiving waters, and downstream in receiving waters (approximately 100 ft from where the discharges enter the streams). The turbidity measurements will be taken upon opening of Flow Impact Offset Facility outlets and taken a minimum of weekly throughout operation of the facility.

5.1.3.4 Dissolved Oxygen

Dissolved oxygen data will be taken at discharge points and approximately 100 ft downstream from where the discharges enter the streams. The DO measurements will be taken upon opening of Flow Impact Offset Facility outlets and taken a minimum of weekly throughout operation of the facility.

5.1.3.5 Temperature

Water temperature will be measured within the vaults, at discharge points, and in the receiving waters (streams). Temperature measurements within the vaults will be obtained using dataloggers that will provide average daily temperature throughout the year. Instream temperature measurements will be taken at the discharge points, upstream in receiving waters, and approximately 100 ft downstream from where discharges enter the streams. The field temperature measurements will be taken a minimum of weekly upon opening of Flow Impact Offset Facility outlets.

5.1.3.6 Metals

Samples will be analyzed for copper, lead, and zinc. The samples will be obtained from discharge points and receiving waters (approximately 100 ft downstream from where discharges enter the streams). The metals sampling and analysis will occur upon opening of Flow Impact Offset Facility outlets and a minimum of monthly throughout operation of the facility.

5.1.3.7 Schedule

Weekly monitoring of the discharges for the quality parameters (except metals) is proposed as a starting point for monitoring the Flow Impact Offset Facility. Once an adequate volume of data exists, an analysis will be completed on the variability of the water quality parameters, and sampling frequencies can be increased or decreased, as appropriate. Data collected during the pilot program will be included in this analysis. Because the facility will be discharging from a stored volume of water, the water quality of the discharges is not expected to change significantly, until runoff

replenishes the vaults. In the event of a significant rainfall event during the operation of the facility (greater than 0.5 inches in a 24-hour period), the Port will conduct additional sampling to ensure that the rainfall did not substantially change the character of the water within the Flow Impact Offset Facility, which could potentially cause a violation of instream water quality standards. Monthly sampling for metals is sufficient because existing data shows that the metals concentrations in stormwater runoff from the airfield is relatively consistent and low compared to stormwater discharges from other urban areas.

5.1.3.8 Locations

Specific monitoring locations, both of the discharges and instream, will be consistent with the requirements of the Section 401 Water Quality Certification and will be precisely located and included in the final design of facilities associated with the Flow Impact Offset Facility. All water quality data will be recorded and reported in an annual monitoring report that will be submitted to Ecology by December 31 of each year. If the monitoring data show that the discharges from the Flow Impact Offset Facility consistently meet water quality standards within the receiving waters, the Port may propose a modified monitoring plan for subsequent operation of the facility. If any water quality problems were encountered during operation of the facilities, the annual report will include a discussion of the immediate actions taken to address the problem and actions taken or proposed to prevent a recurrence of the problem in the future. All sampling and analytical methods used to monitor the Flow Impact Offset Facility will conform to the latest revision of the *Guidelines Establishing Test Procedures for the Analysis of Pollutants* contained in 40 CFR Part 136 or to the latest revision of *Standard Methods for the Examination of Water and Wastewater* (American Public Health Association [APHA] et al. 1998). This will ensure that the monitoring methods for the Flow Impact Offset Facility are consistent with other water quality monitoring done under the NPDES permit for the airport.

5.2 BIOLOGICAL MONITORING

Instream biological monitoring will be performed in Miller, Walker, and Des Moines Creeks to assess the impacts of the Port's Flow Impact Offset Facility. The biological monitoring will consist of Benthic Index of Biotic Integrity (B-IBI) monitoring and physical habitat monitoring. Biological monitoring will occur four times per year and will continue through the fifth year after construction, then annually until completion of a 15-year monitoring period. During the years when monitoring is occurring four times per year, monitoring events will occur in January/February, April/May, June/July, and September/October. If monitoring indicates potential adverse effects, the Port will evaluate potential adaptive management strategies (see Section 5.4, Adaptive Management). The biological monitoring protocols are discussed in the following subsections.

5.2.1 B-IBI Sampling Protocol

5.2.1.1 Approach

A measure of biotic integrity will be used to evaluate the existing and future low-flow conditions of Des Moines, Miller, and Walker Creeks. The B-IBI for Puget Sound Lowlands (Kleindl 1995; Karr and Chu 1997) quantifies the overall biotic condition of a stream based on measured attributes of benthic macroinvertebrates compared to regional distributions. B-IBI scores have been shown to

correlate well with levels of urbanization (Fore et al. 1996; Horner et al. 1996). This analysis was designed to analyze invertebrates collected in the fall (Kleindl 1995; Karr and Chu 1997) and will be used to assess the September/October samples. Invertebrates collected during the other monitoring periods will be assessed using several of the same metrics in the B-IBI, coupled with professional judgement, and will be compared to the fall B-IBI score. The protocol described below is from *Biological Monitoring and Assessment: Using Multimetric Indexes Effectively* (Karr and Chu 1997) and will be applied to samples collected throughout the year.

5.2.1.2 Field Equipment

The following field equipment will be used for the B-IBI monitoring:

- 500-micron mesh Surber type sampler
- 500-micron (or smaller) mesh sieve
- Flagged weight to identify sample location
- Ethyl alcohol (95%)
- Two 1-liter squirt bottles for alcohol
- Garden trowel or large spike to disturb substrate
- White bucket or white wash bin to empty sample from Surber
- Large cup with handle to rinse invertebrates off Surber
- Stop watch
- Forceps (tweezers)
- Plastic spatula
- Waterproof ("Rite-in-the-rain") paper
- Pencil, permanent marker (Sharpie), and grease pencil
- 250-ml screw-top jars (three per sample site)
- Ziploc bags

5.2.1.3 Site Selection

Sample sites will be selected that are representative of the larger study areas. This determination will be based on physiographic characteristics, including vegetation, soils, geology, land use, gradient, riparian characteristics, and substrate. For each representative stream reach, a riffle long enough to accommodate three replicate samples will be identified. Ideal sampling locations will consist of rocks 5 to 10 cm in diameter sitting on top of pebbles. Substrates dominated by rocks larger than 50 cm in diameter will be avoided.

To the extent possible, sample sites will not be located directly downstream from anomalies such as culverts, bridges, roads, landslides, or waterfalls (unless these are the conditions that the monitoring program is evaluating). In situations where an anomaly cannot be avoided, sampling will occur at least 50 meters upstream of a bridge and 200 meters downstream of a bridge. The location of each sample site will be recorded.

5.2.1.4 Data Management

During the B-IBI monitoring, site location data and site selection rationale will be recorded onto electronic datasheets. This information can be collected in a field notebook and recorded onto the B-IBI summary sheet later, or entered directly with the field computer.

5.2.1.5 Invertebrate Collection

Three total replicates will be taken from each sample location using the following methodology:

1. Sample within the main flow of the stream. To the extent possible, sample at water depths of 10 to 40 cm. Depending on low-flow conditions, the sampling may need to occur from shallower water depths. Depth, flow, and substrate type should be similar for the three replicate samples collected in the riffle. Begin sampling downstream and proceed upstream for the three replicates.
2. Place the Surber sampler on the selected spot with the opening of the nylon net facing upstream. Brace the frame and hold it firmly on the stream bottom.
3. Lift the larger rocks resting within the frame and brush off crawling or loosely attached organisms so that they drift into the net. After "cleaning" the rocks, inspect for invertebrates and discard from the sampling area.
4. Once the larger rocks are removed, disturb the substrate vigorously with a trowel or large spike for 60 seconds. This disturbance should extend to a depth of about 10 cm to loosen organisms in the interstitial spaces, washing them into the net.
5. Lift the Surber out of the water and tilt the net up and out of the water while keeping the open end upstream. This will help to wash the organisms into the receptacle. Drop a piece of weighted flagging tape to mark the location of the first replicate sample. Do not step on remaining sample areas while walking to the streambank.
6. On the streambank, empty contents of the Surber into large bucket or wash bin. Remove all animals and debris from the Surber sampler.
7. Separate benthic macroinvertebrates from the substrate by stirring the contents of the plastic wash pan. Pour floating organic matter into a 500- μ m soil sieve, then transfer into a sampling jar and preserve with ethanol (95 percent). Residual water in the sample will dilute the ethanol to about 70 percent.
8. Repeat rinsing and pouring into the 500- μ m soil sieve until all apparent animals are removed from gravel. Add a small amount of water to remaining gravel and set aside for a few moments. Remaining invertebrates will begin to move among the substrate. Use a magnifying glass and tweezers to remove the last animals and place directly into the sample jar.
9. One important note: the density of invertebrates within a riffle can be variable, and there may be times when a sample has low numbers of invertebrates. It is important that a sample have at least 500 individuals (Fore 1999 personal communication). This number will be

estimated in the field by looking at the density of invertebrates in the concentrated sample. If the density appears small, additional combined samples will be necessary.

Archive Sample

Insert a sample label that contains the name of the team, date, location, sample number, and replicate number into the jar. Fill the sample jar to the top with alcohol and seal. Write the location and date on top of the sample lid. Place the jar in a Ziploc bag labeled with the same information.

Collect Replicate Samples

Return to the location of the first sample, walk upstream, and collect another sample of invertebrates. Leave another flagged marker and process the sample as above. Repeat this process once more for a total of three replicate samples from each site location. Each replicate should be labeled (e.g., #1, #2, #3) and archived separately.

Taxonomy

Invertebrates will be identified to the highest possible taxonomic level by a professional invertebrate taxonomist.

5.2.1.6 Reporting

Information obtained from the B-IBI monitoring will be synthesized to evaluate potential impacts associated with operation of the Flow Impact Offset Facility. All B-IBI data will be recorded and reported in the annual monitoring report to be submitted to Ecology by December 31 of each year. If any negative impacts were encountered during operation of the facilities, the annual report will include a discussion of the immediate actions taken to address the problem, and actions taken or proposed to prevent a reoccurrence of the problem in the future.

5.2.2 Physical Habitat Monitoring Protocol

Physical habitat monitoring will be used to evaluate the existing and future low-flow conditions of Miller, Walker, and Des Moines Creeks. Protocols for the physical habitat monitoring are provided in Appendix G.

5.3 FILL MONITORING, INFILTRATION BMPS, AND INFILTRATION CONTINGENCY MEASURES

The hydrogeologic modeling by Hydrus and Slice described in Section 2.3 modeled the movement of precipitation that has infiltrated into the fill embankment. The properties of the fill (e.g., grain size distribution) largely control the amount of water that will infiltrate and water movement through the embankment. Additional factors include the methods of fill placement, final grading, and revegetation. The following section describes the monitoring plan for confirming infiltration properties of the in-place fill.

5.3.1 Existing Fill Quality Control Testing

The embankment construction specification (Specification P-152) establishes that proposed fill sources be tested for acceptance by the Port at least 30 days prior to the proposed use of the fill. Submittal requirements include the following tests, which must all be performed in accordance with American Society for Testing and Materials (ASTM) D 3740 (Minimum Requirements for Agencies Engaged in the Testing and/or Inspection of Soil and Rock as Used in Engineering Design and Construction):

- Sieve analysis and natural moisture content (ASTM C 136)
- Specific gravity (ASTM D 854 or C 127)
- Moisture/density relationship (ASTM D 1557)
- Plasticity index for Group 4 soils (ASTM D 4318)
- Environmental certification report
- Direct shear test for Group 5 soil (ASTM D 3080)

The data must be certified by a licensed geotechnical engineer ensuring that they accurately represent material from the source site. Use of the fill is subject to approval by a Port engineer (Specification P-152-2.1).

The density of in-place fill is tested in "lots" for approval of the lot by a Port engineer (a "lot" is 2000 tons of material in place) in accordance with ASTM D 1556, ASTM D 2167, or ASTM D 2922 (Specification P-152-2.3). In addition, every other lot of Group 1A must be tested by the contractor for fines content in accordance with ASTM C 136.

5.3.2 New Infiltration Capacity Testing Protocol for Fill

In addition to established quality control testing procedures for the fill, tests will be performed to evaluate infiltration capacity. The infiltration capacity measured in the field can be related to infiltration capacity assumptions used in embankment modeling. For modeling, infiltration capacity and hydraulic conductivity were assumed equal and the fill was characterized as a uniform mixture of two media: an inactive gravel fraction, and an active matrix through which unsaturated flow occurred (Pacific Groundwater Group 2001). If macro-pore flow is absent and entrapped air in the soil is minimal during field testing, the following equations define the relationship between bulk infiltration capacity measured in the field and modeled hydraulic conductivity of the fill matrix:

$$I_b = I_m(1-\%G)$$

and $I_m = K_m$

where I_b = bulk infiltration capacity measured in the field
 I_m = matrix infiltration capacity
 $\%G$ = fraction of the fill that is gravel
 K_m = saturated hydraulic conductivity of the soil matrix, appropriate as input for modeling variably saturated flow

An important variable in the general water balance of the embankment is the infiltration capacity of the surficial soils. The general water balance is less sensitive to the character of soils buried within

the embankment. Therefore, infiltration testing will only be performed when the embankment is nearing completion. It is assumed for purposes of these calculations that no "topsoil" or other distinct surficial layer will be placed on the embankment. If such a layer is decided upon in the future, the timing, locations, and depth of infiltration tests may require alteration from the protocol established below.

Infiltration testing will be performed upon substantial completion of the embankment, including establishment of the various zones (fill types) that will comprise the surface of the embankment. Up to eight locations on top of the new embankment fill will be selected by the Port based on the following criteria:

- Provide geographic coverage of pavement subgrade, pavement support, and common embankment zones of the new fill as shown in Figure 7 of the *Geotechnical Engineering Report, 404 Permit Support, Third Runway Embankment, Sea-Tac International Airport* (Hart Crowser 1999). Testing of the "MSE reinforcing" fill zone will not be performed.
- Remain safely away from air traffic operations.
- Remain safely away from utilities.
- Consider access for water trucks.

At each location, a modified Pilot Infiltration Test (PIT) described in the *Stormwater Management Manual for Western Washington* (Ecology 2001) will be performed. An area of at least 100 ft² will be accurately leveled and bermed to allow ponding of imported water (shallow excavations may be used). Turbidity-free water at ambient temperature will be metered into the basin and discharged onto a permeable geotextile to prevent disturbance of the soil surface. Initial ponding may be maintained at substantial depth but not to exceed 1 ft. After at least 17 hours of continuous ponding, the pond depth will be decreased by reduction of discharge to the minimum pond depth necessary to completely cover the basin bottom. The water discharge rate required to maintain a constant minimal ponding depth will be measured. When that water flow rate has not changed substantially over a duration of 1 hour, the test will be terminated. The following equation will be used to calculate bulk infiltration capacity using the test data (in consistent units):

$$I_b = \text{steady water flow rate} / \text{area of basin bottom}$$

For instance, if the steady water flow rate is 25 cf per hour into a basin of 100 ft², the infiltration capacity is 0.25 ft per hour (3 inches per hour or 2×10^{-3} cm/sec).

To support interpretation of the infiltration tests, orthogonal photographs of the basin bottoms will be taken with a visible scale. A large volume bulk soil sample will also be collected by digging into the basin bottom. The sample will be retained as a contingency should questions about the test arise. Data collection and reporting guidelines supplied in Ecology's PIT procedures will also be followed.

5.3.3 Fill Infiltration Performance Criterion

The infiltration capacity of the built embankment will be considered substantially lower than that used in modeling if the K_m used in modeling (1.35×10^{-4} cm/sec) falls above the upper 95 percent confidence interval of the infiltration test population (the K_m values, or a fitted population distribution, calculated from the infiltration test data). This approach will identify field conditions wherein the built embankment has an infiltration capacity substantially less than assumed in modeling.

No similar criterion will be applied to identify conditions wherein the built embankment has a substantially higher infiltration capacity than assumed for modeling. Reasons for this are: (1) the greater concern is building an embankment that infiltrates too little water, and (2) the proposed approach does not require correcting for macro-pore flow that will likely influence the field data.

5.3.4 Fill Infiltration BMPs

BMPs designed to promote infiltration into the embankment are described in the October 26, 2000 HNTB memorandum (Appendix C). The BMPs are limited to use of flatter slopes on the airfield, longer water courses over pervious surfaces, and use of a variety of naturally occurring fill materials. Other measures were deemed inappropriate because of increased risk of instability, construction complexity, and costs, and possible adverse impacts. The three acceptable BMPs are used in the current design of the embankment.

In addition to the three BMPs discussed in the attached memo, a polyacrylamide (PAM) tackifier has been, and will continue to be, used to reduce erosion of the embankment surfaces. A procedure for application of the PAM is attached. PAM has been shown to increase infiltration of irrigation water into soil as a result of stabilization of soil structure. Also, in a partial deviation from Specification P-152, truck traffic will be routed across a minimal area of the embankment upon placement of the final 2 ft of fill. This deviation will not affect the density specification required for engineering acceptance of the constructed fill.

If the measured infiltration capacity of the constructed embankment is substantially lower than used in modeling and anticipated by use of the above BMPs, implementation of contingency measures may be warranted, based on long-term monitoring data as described above.

5.3.5 Fill Infiltration Contingency Measures

Embankment modeling and infiltration testing are only proposed for the third runway fill. Therefore, the contingency measures outlined below are only applicable to the third runway fill.

If the infiltration capacity of the third runway fill is substantially lower than assumed for embankment modeling, the infiltration tests will be rerun after the establishment of vegetation. The post-vegetation tests will be conducted and interpreted in the same fashion as the pre-vegetation tests, except that flat areas will be bermed with soil for use as basins, and excavations will not be used. Vegetation will be maintained within the bermed areas while preparing the basins for testing.

If the post-vegetation infiltration capacity of the third runway fill appears substantially lower than assumed for embankment modeling, long-term monitoring data will be interpreted to allow the Port

to adapt water management practices to the as-built condition. This approach is appropriate given the fact that infiltration capacity is only one of many variables involved in determining the as-built water budget, and responding solely to a changed condition in the infiltration capacity could be unnecessary or even misguided given other potential differences between predicted and as-built conditions. Collecting and responding to long-term monitoring data is preferable because it considers the aggregated effects of all factors. Long-term hydrologic and environmental monitoring is discussed in response to Condition I(e). Based on that monitoring, plans will be developed as necessary to respond to adverse conditions not mitigated by existing designs.

5.4 ADAPTIVE MANAGEMENT

The Flow Impact Offset Facility and its Operation and Maintenance Plan are being developed to facilitate an adaptive management strategy. Comprehensive programs are proposed to monitor the facility's performance, and changes to the facility or its operation will be made to meet the performance standards. Monitoring programs will address water quality, water quantity, fill parameters and infiltration performance, impacts to stream biology, and impacts to wetlands. Monitoring programs are discussed in Sections 5.1 and 5.2. Some potential adaptive management strategies are discussed below.

Water quality will be extensively monitored. The discharges from the reserved vaults will be monitored, as well as instream water quality in each stream. In addition, test discharges will be monitored prior to activation of the facility each year. If any instream water quality violations are detected, or if it is determined that the potential to cause an instream water quality violation exists, appropriate action will immediately be taken to correct the situation. Potential contingency actions include unscheduled maintenance of BMPs or the addition of other BMPs (filtration, mechanical aeration, etc.).

Water quantity will be monitored, including vault filling rates, discharge rates, and instream flow at gaging stations. Adaptive management strategies would include the development of modified schedules for vault filling, adjustment of the impervious areas that contribute to filling the reserved vaults, and adjustment of the discharge structures to maintain the target flow.

Tests will be conducted to evaluate infiltration capacity of the embankment fill. The measured infiltration will be compared to the infiltration assumptions used in the low-flow analysis (see Section 5.3). If the assumptions are not being met, potential adaptive management strategies include aeration (perforation) of infiltration surfaces, soil amendments, and regrading surfaces.

Wetlands and stream biology will be monitored during operation of the facility. If impacts are observed, potential adaptive management strategies include revising the operating schedule of the facility to optimize the timing and amount of discharge to the streams.

6. REFERENCES

- Abbe, T.B. and D.R. Montgomery. 1996. Large woody debris jams, channel hydraulics and habitat formation in large rivers. *Regulated Rivers: Research & Management* 12:201-221.
- APHA (American Public Health Association), American Water Works Association, and Water Environmental Federation. 1998. *Standard methods for the examination of water and wastewater*. 20th edition.
- Armantrout, N.B. (compiler). 1998. *Glossary of aquatic habitat inventory terminology*. American Fisheries Society, Bethesda, Maryland.
- Bauer, S.B. and T.A. Burton. 1993. *Monitoring protocols to evaluate water quality effects of grazing management on western rangeland streams*. U.S. Environmental Protection Agency Region 10, Seattle, Washington.
- Bovee, K.D. 1982. *A guide to stream habitat analysis using the Instream Incremental Methodology*. Instream Flow Information Paper 12, FWS/OBS-28/26, Co-operative Instream Flow Group, U.S. Fish and Wildlife Service, Office of Biological Service.
- Collins, B.D., D.R. Montgomery, and A.D. Haas. 2001. *Historic changes in the distribution and functions of large woody debris in Puget Lowland rivers*. Submitted to *Canadian Journal of Fisheries and Aquatic Science*.
- Earth Tech, Inc. 2000. *Low streamflow analysis for Seattle-Tacoma Airport Master Plan Update*. Prepared by Earth Tech for the Port of Seattle. Bellevue, Washington.
- Ecology (Washington State Department of Ecology). 2001. *Stormwater management manual for Western Washington*.
- EPA (U.S. Environmental Protection Agency). 1997. *Hydrological Simulation Program - FORTRAN*. Prepared by AQUA TERRA Consultants, Stockton, California. Prepared for Office of Surface Water, U.S. Geological Survey, Reston, Virginia.
- Fore, L.S., J.R. Karr, and R. Wisseman. 1996. Assessing invertebrate responses to human activities: Evaluating alternative approaches. *Journal of the North American Benthological Society* 15(2):212-231.
- Fore, L. 1999. Personal communication. Leska Fore - Statistical Design, Seattle, Washington.
- Hart Crowser. 1999. *Geotechnical engineering report, 404 permit support, third runway embankment, Sea-Tac International Airport*. Prepared by Hart Crowser for the Port of Seattle.
- Homer, R.R., D.B. Booth, A. Azous, and C.W. May. 1996. *Watershed determinants of ecosystem functioning*. Proceedings of an Engineering Foundation Conference. American Society of Civil Engineers, Snowbird, Utah.

- Karr, J.R. and E.W. Chu. 1997. Biological monitoring and assessment: Using multimetric indexes effectively. University of Washington, Seattle, Washington.
- Kleindl, W.J. 1995. A benthic index of biotic integrity for Puget Sound lowland streams, Washington, USA. M.S. Thesis, University of Washington, Seattle, Washington.
- Lindsey, A.A., J.D. Barton Jr., and S.R. Miles. 1958. Field efficiencies of forest sampling methods. *Ecology* 39(3):428-444.
- May, C.W., E.B. Welch, R.R. Horner, J.R. Karr, and B.W. Mar. 1997. Quality indices for urbanization effects in Puget Lowland streams. Report prepared for Washington Department of Ecology. Water Resources Series Technical Report No 154.
- Pacific Groundwater Group. 2000. Sea-Tac runway fill hydrologic studies report. Prepared by Pacific Groundwater Group for Washington State Department of Ecology. Seattle, Washington.
- Pacific Groundwater Group. 2001. Port of Seattle Sea-Tac third runway embankment fill modeling in support of low-streamflow analysis. Prepared by Pacific Groundwater Group for Port of Seattle. Seattle, Washington.
- Parametrix, Inc. 2000a. Comprehensive stormwater management plan for Seattle-Tacoma International Airport Master Plan Update improvements. Prepared by Parametrix for the Port of Seattle. Kirkland, Washington.
- Parametrix, Inc. 2000b. Natural resource mitigation plan for Seattle-Tacoma International Airport Master Plan Update improvements. Prepared by Parametrix for the Port of Seattle. Kirkland, Washington.
- Parametrix, Inc. 2001a. Replacement pages for the comprehensive stormwater management plan for Seattle-Tacoma International Airport Master Plan Update improvements. Prepared by Parametrix for the Port of Seattle. Kirkland, Washington.
- Parametrix, Inc. 2001b. Wetland functional assessment and impact analysis for Seattle-Tacoma International Airport Master Plan Update improvements. Prepared by Parametrix for the Port of Seattle. Kirkland, Washington.
- Paustian, S.J. (editor) and 13 others. 1992. A channel type users guide for the Tongass National Forest, Southeast Alaska. USDA Forest Service, Alaska Region, R10 Technical Paper 26. 179 pp.
- Platts, W.S., W.F. Megahan, and G.W. Minshall. 1983. Methods for evaluating stream, riparian, and biotic conditions. USDA Forest Service General Technical Report INT-GTR-188.
- Port of Seattle. 2000a. Annual stormwater monitoring report for Seattle-Tacoma International Airport for the period July 1, 1999 through June 30, 2000.

- Port of Seattle. 2000b. Examining the effects of runway deicing on dissolved oxygen in receiving waters: Results of the 1999-2000 winter season, Seattle-Tacoma International Airport. Volume 1.
- Port of Seattle. 2001a. Low flow analysis, flow impact offset facility proposal, Seattle-Tacoma International Airport. Seattle, Washington.
- Port of Seattle. 2001b. Annual stormwater monitoring report for Seattle-Tacoma International Airport for the period July 1, 2000 through June 30, 2001.
- R2 Resources Consultants, CH2M Hill, and Shapiro and Associates. 2000. Tri-County urban issues ESA study: Guidance document. February 2000. Prepared for the Tri-County Urban Issues Advisory Committee, Bellevue, Washington.
- Schuett-Hames, D., A. Pleas, L. Bullchild, and S. Hall (eds.). 1994. Ambient monitoring program manual. Timber-Fish-Wildlife, TFW-AM9-94-001. Northwest Indian Fisheries Commission, Olympia, Washington.
- Simunek, J., M. Senjna, and M.T. van Genuchten. 1999. Hydrus/Meshgen-2D – Simulating water flow and solute transport in two-dimensional variably saturated media. Version 2.0. U.S. Salinity Laboratory, USDA/ARS. Distributed by International Groundwater Modeling Center.
- USFS (United States Forest Service). 1999. Stream inventory handbook: Level I & II. USDA, Region 6, Version 9.9.
- Wang, L., T.D. Simonson, and J. Lyons. 1996. Accuracy and precision of selected stream habitat estimates. *North American Journal of Fisheries Management* 16:340-347.
- WDFW (Washington Department of Fish and Wildlife). 2000. Fish passage barrier and surface water diversion screening assessment and prioritization manual. WDFW Habitat Program Environmental Restoration Division: Salmonid Screening, Habitat Enhancement, and Restoration (SSHEAR) Section. Olympia, Washington.
- WFPB (Washington Forest Practices Board). 1997. Standard Methodology for Conducting Watershed Analysis under Chapter 222-22 WAC. Version 4.0, November 1997. Washington Department of Natural Resources, Olympia, Washington.
- Williams, R.W., R.M. Laramie, and J.J. Ames. 1975. A catalog of Washington streams and salmon utilization. Vol. 1. – Puget Sound. Washington Department of Fish and Wildlife, Olympia, Washington.



NOTE: Appendix A—HSPF Modeling Information and Data—is contained in a separate volume.

APPENDIX B
EMBANKMENT MODELING REPORT



**Pacific
Groundwater
Group**

**Port of Seattle
Sea-Tac Third Runway
Embankment Fill Modeling in Support of Low-
Streamflow Analysis**

November 27, 2001

Pacific Groundwater Group
Seattle, Washington

AR 019964

**Port of Seattle
Sea-Tac Third Runway
Embankment Fill Modeling in Support of Low Streamflow Analysis**

Prepared for:

Port of Seattle
P.O. Box 68727
Seattle, WA 98168

Prepared by:

Pacific Groundwater Group
2377 Eastlake Avenue East, #200
Seattle, WA 98102
(206) 329-0141
www.pgwg.com

November 27, 2001

JE0105

Table of Contents

1. INTRODUCTION 1
1.1 Scope and Approach 1
2. EXTENT OF FILL MODELED BY HYDRUS-SLICE 3
2.1 Geographic Extent of Fill 3
2.2 Thickness of Fill 3
2.3 Basin Boundaries and Area Calculations 4
3. MODELING OF INFILTRATION WITH RUNOFF AND EVAPOTRANSPIRATION 4
3.1 HSPF Input and Runoff Calculations 4
3.2 Effective Recharge 6
4. MODELING OF VERTICAL FLOW THROUGH EMBANKMENT FILL 6
4.1 Summary of Generic Hydrus Model 6
4.2 Characterization of Fill as Soil 6
4.2.1 General Fill 7
4.2.2 Type 1 Fill 7
4.3 Representation of Fill in Hydrus 7
4.4 Spatial Discretization of Hydrus Models 9
4.5 Temporal Discretization 9
4.6 Results 9
5. MODELING SATURATED FLOW BENEATH THE EMBANKMENT FILL 10
5.1 Cross Section 1 and Slice 1 12
5.2 Cross Section 2 and Slice 2 12
5.3 Cross Section 3 and Slice 3 12
5.4 Individual Slice Model Results 13
5.5 Method for Integrating Slice Results Over Entire Fill Areas 14
5.6 Effective Basin Width for Walker Creek 15
5.7 Effective Basin Width for Miller Creek 15
5.8 Integrated Flow Estimates for Walker Creek Fill 16
5.9 Integrated Flow Estimates for Miller Creek Fill 16
5.10 Use of Integrated Flow Estimates 17
6. REFERENCES 17

Signature Page

This work was performed in part, and reviewed in whole, by the undersigned.

Charles T. Ellingson 11/27/01

Charles T. Ellingson
Pacific Groundwater Group Principal Hydrogeologist
Oregon Registered Geologist G1128
Idaho Registered Geologist 1008
Certified Groundwater Professional #312 (National Ground Water Association)

List of Tables

Table 2-1	Summary of Areas Modeled by Hydrus-Slice
Table 3-1	Summary of Water Volumes
Table 4-1	Summary of Hydraulic Parameters Used for Fill Matrix in the Hydrus-2D Model
Table 5-1	Slice 1 Model Parameters for Different Cell Types
Table 5-2	Slice 1 Model Cell Parameters
Table 5-3	Slice 2 Model Parameters for Different Cell Types
Table 5-4	Slice 2 Model Cell Parameters
Table 5-5	Slice 3 Model Parameters for Different Cell Types
Table 5-6	Slice 3 Model Cell Parameters
Table 5-7	Summary of Effective Basin Widths for Walker and Miller Creek Flow Estimates

List of Figures

Figure 2-1	Site Features for Hydrus-Slice Modeling
Figure 4-1	Hydrus Output for Miller Creek Fill - Water Years 1991-1994
Figure 4-2	Hydrus Output for Walker Creek Fill - Water Years 1991-1994
Figure 5-1	Simplified Cross Section for Slice 1
Figure 5-2	Simplified Cross Section for Slice 2
Figure 5-3	Simplified Cross Section for Slice 3
Figure 5-4	Model Results for Slice 1 Simulation - Water Years 1991-1994
Figure 5-5	Model Results for Slice 2 Simulation - Water Years 1991-1994
Figure 5-6	Model Results for Slice 3 Simulation - Water Years 1991-1994
Figure 5-7	Walker Creek Fill Inflow and Outflow for Test Period
Figure 5-8	Miller Creek Fill Inflow and Outflow for Test Period

1. Introduction

The Port of Seattle ("the Port") proposes to place a fill embankment in an area west of the existing Sea-Tac Airport complex to build a third runway. Pacific Groundwater work analyzed selected hydrologic impacts for the Department of Ecology in 1999 (Pacific Groundwater Group, 1999). Hydrologic and hydrogeologic studies conducted by Earth Tech, Inc., Parametrix, Inc., Pacific Groundwater Group (PGG) and others then estimated groundwater and low-stream-flow impacts of the proposed fill embankment (Earth Tech, 2000; Pacific Groundwater Group, 2000; and Parametrix, 2001). As part of a more detailed study of low flow impacts to streams near the third runway, the Port contracted Parametrix, Earth Tech and PGG to reevaluate low-stream-flow impacts using a more detailed evaluation of hydrogeologic conditions and fill thickness in the embankment. PGG's role in the more detailed evaluation was to model recharge and redistribution of water within the fill embankment. This is the final report for PGG's portion of that project. The overall project study area includes the Miller Creek and Walker Creek basins, whereas PGG's evaluation was limited to a smaller portion of these basins that are proposed to be underlain by third-runway fill. PGG's evaluation was also limited to post-construction conditions, and did not attempt to simulate existing conditions or use existing conditions for calibration. PGG's study results were used by the HSPF modeling team to evaluate low-stream-flow impacts in the two basins.

1.1 Scope and Approach

PGG's scope of work was authorized by the Port on May 1, 2001. PGG's scope involved reapplication of previously-developed Hydrus and Slice models to post-construction conditions within the proposed embankment as follows:

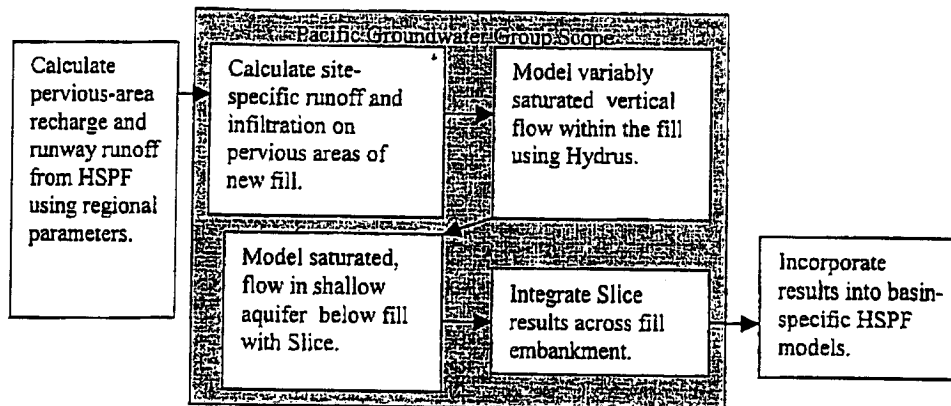

Input to the modeling process consisted of the following two data sets provided to PGG by Aqua Terra Consultants:

1. direct infiltration from incident precipitation into pervious areas of new fill as calculated by HSPF (model parameter AGWI) for flat outwash
2. runoff from runways and taxiways as calculated by HSPF (model parameter SURO).

Output consisted of the timing and magnitude of runoff from the pervious area, water movement through the shallow aquifer above the till, and downward flow through the till. Output was provided to Aqua Terra and Parametrix Inc. as part of basin-wide simulation of post-construction conditions. The regional HSPF models were modified to allow replacement of regional-scale simulation with local-scale simulation (as described above) in the third runway vicinity. Specifically, Hydrus and Slice models ("Hydrus-Slice") were used instead of the regional HSPF model for the runway fill area, because HSPF was deemed incapable of simulating flow within the embankment. A simulation "test period", consisting of water years 1991 through 1994, was established for Hydrus-Slice modeling in discussions between the Port and the Department of Ecology ("Ecology").

The PGG scope consisted of the following tasks:

- Compile model input using existing information including
 - Fill thickness and extent
 - Hydrogeologic data for the fill area
 - Embankment geometries as represented by three (3) hydrogeologic cross sections
 - Hourly runoff and direct infiltration estimates provided by Aqua Terra Consultants
- Calculate fluxes into the fill based on hourly recharge and runoff estimates
- Calculate daily fluxes through the fill using Hydrus models
- Calculate daily flux through the shallow aquifer at the base of the embankment and the underlying till using Slice models as applied to each basin

Original modeling using the Hydrus-Slice approach was reported on August 8, 2001 (Pacific Groundwater Group, 2001). The modeling reported in this revised report was performed because the original modeling used HSPF parameter AGWO as input instead of the more appropriate parameter AGWI. In addition, the following improvements and changes were made to the revised groundwater modeling:

- PGG adopted the HSPF basin boundary to define the eastern extent of new fill instead of independently-derived boundaries. The independently-derived boundary used in original modeling was similar to the HSPF basin boundary, but not exactly the same. This is a small mathematical change, not a conceptual change.
- PGG included the 1998 fill as third runway fill. Original modeling excluded the 1998 fill because the air-photo-based elevation contours used to calculate fill thickness were flown after placement of the 1998 fill. This change results in a somewhat larger Miller Creek fill area than was originally modeled.

- PGG calculated runoff from pervious areas instead of assuming that all precipitation and runoff becomes groundwater recharge. The use of hourly infiltration (AGWI) and runoff (SURO) data from HSPF results in prediction of runoff from filter strips (a portion of the pervious area next to the runways) that simultaneously receive precipitation and runway runoff. This is a more accurate accounting of water performed for the proposed third runway fill area.
- Hydrus 1-D was used to model variably-saturated flow in the fill instead of Hydrus 2-D that was originally used. Hydrus 1-D was required for the revised simulations because it remains stable under the wetter and more variable conditions predicted by the AGWI and SURO model input.

The work was performed, and this report prepared, in accordance with generally accepted hydrogeologic practices, used at this time and in this vicinity, for sole application to the simulation of low-flows under the built condition, and for the sole use of the Port of Seattle. This is in lieu of other warranties, express or implied.

2. Extent of Fill Modeled by Hydrus-Slice

The modeled fill area (MFA) represents a portion of third runway fill, within the Walker and Miller creek groundwater basins, that would receive precipitation in a post-construction ("built") condition. This area was selected based on discussions with HSPF modelers at the onset of the project. The area was modeled by Hydrus-Slice rather than HSPF for the built condition.

2.1 Geographic Extent of Fill

PGG used existing GIS coverages of pre-fill topography, "built" topography, and third runway pavement distribution to calculate areas for Hydrus-Slice modeling. A graphical approximation of the areas modeled by Hydrus-Slice (and therefore removed from the HSPF model) is shown on **Figure 2-1**. The MFA includes proposed additional runway fill in the Miller and Walker Creek basins minus the steep perimeter slopes along the western and northern edges of the embankment. Steep perimeter slopes were not included in the Hydrus-Slice MFA because surface runoff is assumed to dominate flow in these areas and HSPF is better suited to model these hydrologic conditions. The eastern margin of the MFA is defined by the limit of proposed third runway fill as previously determined by HSPF modelers.

2.2 Thickness of Fill

Fill thickness was calculated by subtracting GIS coverages of pre-fill topography from the "built" topography. A fill thickness of up to 160 feet occurs behind the West Mechanically-Stabilized-Earth (MSE) wall with significantly less fill occurring over most of the third runway area (**Figure 2-1**). For the purpose of Hydrus modeling, fill thickness

was descriptized into representative values of 10, 20, 30, 50, 70, 90, 110, 130, and 150 feet. Fill thickness in the area of the 1998 fill was approximated and not directly calculated as the difference between two sets of elevations.

2.3 Basin Boundaries and Area Calculations

Groundwater basin boundaries for Miller, Walker and Des Moines Creeks were located for purposes of allocating modeled groundwater flows in the MFA. The groundwater basin boundary of greatest significance in this study is the Miller-Walker divide because these are the receiving basins for groundwater discharge from the fill. A dashed line is drawn on **Figure 2-1** between the Miller and Walker Creek basins. The location of the line is co-incident with the surface water and groundwater basin boundaries used in the HSPF models of 1994 conditions (Parametrix, 2000, Figure B2-2 of Stormwater Management Plan). The Walker-Des Moines groundwater divide is south of the fill area, thus groundwater discharge from the fill will not flow to Des Moines Creek under the current or built condition. The fill areas presented in **Table 2-1** are derived from the basin boundary and model area perimeter shown on **Figure 2-1**. Areas are broken into impervious areas (IA), filter strips (FS), and other pervious areas (OPA). Impervious areas comprised 36 percent and 38 percent of the modeled fill areas in the Miller and Walker Creek basins, respectively.

IA in Walker Creek consists of only the western half of the third runway because runoff from the eastern half will drain to the east and will not flow onto new third runway fill. Runoff from the eastern half of the third runway in Walker Creek was modeled by HSPF.

3. Modeling of Infiltration with Runoff and Evapotranspiration

Precipitation on the MFA was used to calculate hourly runoff (SURO) from impervious surfaces (runway and taxiways) and hourly infiltration (AGWI) into pervious areas with a generic application of HSPF. Pervious areas were modeled as grass on flat outwash. This approach was selected, with agreement from Ecology and King County, to take advantage of HSPF's superior evapotranspiration (ET) and runoff-modeling capabilities. For pervious areas, the generic HSPF model yielded hourly volumes of water that infiltrate beyond the bottom of the root zone (AGWI) and therefore constitute groundwater recharge. That calculation was applied to filter strips and other pervious areas. A separate calculation then estimated the extent to which runoff from impervious surfaces would also infiltrate, or conversely, runoff, from filter strips. The total amount of infiltration into filter strips (a portion of AGWI and SURO) and other pervious areas (AGWI only) was then used as input to the Hydrus models. Calculated runoff was accounted-for but not used in groundwater modeling.

3.1 HSPF Input and Runoff Calculations

Aqua Terra accounted for precipitation, runoff, infiltration, and ET on an hourly basis between 1984 and 1994 using HSPF and regional parameters for grass on outwash soils

with land slopes of less than five percent (Joe Brascher, personal communication, May 17, 2001). HSPF model output (AGWI) provided daily estimates of recharge below the root zone considering the effects of runoff and evapotranspiration.

HSPF also calculated hourly volumes of runoff (SURO) from a typical acre of impervious surface. Runoff from impervious surfaces will be routed into "filter strips" that treat the water prior to storage and discharge. The filter strips are part of the pervious surface of the new fill. Therefore, the SURO and AGWI water volumes were added together and compared to the infiltration capacity of the filter strips. Water in excess of the infiltration capacity of the filter strips was considered runoff, and remaining water was considered to infiltrate and become groundwater recharge. For these calculations, areas of impervious surface and filter strips were based on GIS analysis of design data. Flow was assumed uniform over the filter strip, and likely storage of water in surface irregularities was ignored. The infiltration capacity was calculated as the saturated hydraulic conductivity of the fill under a unit hydraulic gradient, over the area of the filter strip. The saturated hydraulic conductivity of the sandy fill matrix was assumed to be 1.35×10^{-4} cm/sec, and no flow was assumed to occur through the portion of the fill occupied by gravel particles, consistent with assumptions throughout PGG's involvement with this project. The total volume of runoff from the filter strips was 28 and 21 percent of the summed AGWI and SURO volumes for Miller and Walker Creek basins, respectively (water years 1991 through 1994 - Table 3-1).

A small amount of runoff was also calculated for "other pervious areas" (pervious areas that are not filter strips and therefore do not receive runoff) because AGWI exceeded the calculated infiltration capacity of other pervious area on occasions. This presumably occurred because of differences between HSPF predictions of runoff from flat outwash, and the runoff-evaluation method applied to the AGWI time series after receipt. The total volume of runoff from the other pervious areas was 6 percent of the AGWI volumes for both basins (water years 1991 through 1994 - Table 3-1).

The Port collected water stage measurements in a sedimentation pond that collected runoff from Phase I (1998) fill of the third runway fill embankment (Parametrix, 2000). The data were collected over about a one-month period in February 1999 and were later used by Parametrix to derive parameters for HSPF modeling of the fill. The interpretation implies a soil infiltration capacity (related to vertical hydraulic conductivity) that is lower than that of regional HSPF parameters for glacial till. The revised runoff calculations summarized above are in much better agreement with observed runoff volumes than the negligible runoff volumes assumed for original modeling reported on August 8, 2001. The observed and predicted runoff volumes are considered to be reasonably consistent although differences in the details may exist for a variety of reasons. As described in Section 4.3, the infiltration volume used in the current modeling could underestimate, and is not likely to over-estimate, actual infiltration. Modeled volumes of groundwater discharge from the fill may therefore be smaller, and are not likely to be larger, than actual discharge. For the purposes of low-flow streamflow assessment, this condition is considered conservative.

3.2 Effective Recharge

Effective recharge (ER) is the average downward groundwater flux over the entire pervious area, just below the root zone. It consists of those portions of AGWI and SURO that infiltrate. As discussed above, the filter strips and other pervious areas receive different amounts of water. In order to simplify the analysis, the *average* effective recharge for the entire pervious area was calculated as the summed volume of water infiltrated in those two areas, divided by the total pervious area. Table 3-1 summarizes those water volumes.

4. Modeling of Vertical Flow Through Embankment Fill

Modeling of downward vertical flow through embankment fill describes water movement in the unsaturated or "vadose" zone between the land surface and the proposed drainage layer at the base of the fill. Downward unsaturated flow is the intermediate step between recharge at the land surface and saturated groundwater flow in the shallow aquifer (simulated by the Slice model). An overview of the unsaturated flow modeling completed for this study is presented in the following subsections.

4.1 Summary of Generic Hydrus Model

Vertical flow of effective recharge between the root zone and the water table within the embankment drainage layer was evaluated using the model Hydrus-1D, hereafter called "Hydrus" (Simunek and others, 1999). Hydrus simulates the vertical spreading of recharge fronts as they are predicted to move downward through the proposed embankment fill. Model results describe the lagging and dampening of the recharge pulse for different thicknesses of fill material. Hydrus output was used as recharge input to the Slice models (Section 5).

With the exception of using HSPF-derived recharge input values instead of values derived from average monthly rainfall, the modeling approach used in this study was conceptually identical to the Hydrus simulations completed for the Ecology study (see Appendix C of Pacific Groundwater Group, 2000). Soil characteristics were unchanged. Independent model runs were conducted for the Miller Creek basin using fill thicknesses of 150, 130, 110, 90, 70, 50, 30, and 10 feet. Model runs were conducted for the Walker Creek basin using fill thicknesses of 50, 30, 20, and 10 feet. Hydrus results indicate that substantial lagging and dampening (spreading) of seasonal recharge is likely within the fill, with the amount of lagging and dampening increasing with increased fill thickness. Discharge at the bottom of the fill is predicted to occur throughout the year.

4.2 Characterization of Fill as Soil

The texture of the modeled fill was calculated based on specifications for Phase 1 fill (installed in 1998 and 1999) and proposed embankment composition described by Hart

Crowser (1999). The calculations were also compared to the texture of Phase 1 fill based on soil samples collected by Terra Associates (1998). Details of the characterization of fill texture relative to Hydrus model input is presented in Appendix C of the Ecology study (Pacific Groundwater Group, 2000). Following are summaries of the two types of fill proposed for use in the embankment and designated in this study.

4.2.1 General Fill

Except for Type 1 soils used as fill in limited areas near the MSE walls and runways, the embankment will be comprised of imported material termed "general fill." Average bulk texture for the general fill was estimated to be 55 percent gravel and 45 percent sand-plus-fines matrix. The sand-plus-fines matrix was further estimated to be comprised of an average of 63 percent sand and 37 percent silt; clay was assumed to be absent. Soil-moisture characteristic curves and hydraulic conductivity distributions were developed for the Hydrus runs using Hydrus' version of the U.S. Soil Salinity Laboratory's computer program "Rosetta" based on the grain-size distribution of the matrix.

4.2.2 Type 1 Fill

According to embankment designs presented by Hart Crowser (1999), Type 1 soils are comprised of sand and gravel; they contain virtually no fines. These materials will be used as backfill for the MSE walls and under runways where greater compaction and drainage properties are required. Type 1 soils were assumed to be infinitely permeable and therefore provide immediate delivery of recharge to the underlying drain layer in the Slice models. Type 1 soils were therefore not modeled explicitly using Hydrus although recharge to the drain layer was considered where Type 1 soils existed in modeled areas.

4.3 Representation of Fill in Hydrus

The sand-plus-silt matrix was modeled as an evenly-distributed 45 percent of the general fill and all water flow was assumed to occur within this active matrix. To maintain a water balance while modeling water flow only through the active matrix, effective recharge values were divided by 0.45 and used as the upper boundary condition flux in Hydrus. This matrix-scaled recharge rate used in Hydrus is called the "effective matrix recharge." Logic for using this rate can be understood by considering that any precipitation falling-on, or percolating-into, clusters of gravel particles is likely to be absorbed by the surrounding sand-plus-silt matrix somewhere within the embankment. The gravel fraction of the general fill is therefore treated as inactive. The output at the bottom of the Hydrus model was then multiplied by 0.45 to redistribute flux to the bulk fill body and maintain a long-term water flux equal to the effective recharge rate.

Modeled hydraulic properties for the active fill matrix were generated with Rosetta, based on the percentages of sand and silt summarized in Section 4.2. Rosetta provides estimates of five parameters used to generate the soil moisture characteristic curve; saturated water content, residual water content, "alpha", "N", and "M" (van Genuchten, 1980). Rosetta

also provides an estimate of saturated hydraulic conductivity and a factor "L" used to relate the characteristic curve to the unsaturated hydraulic conductivity curve (Mualem, 1976). A default "L" value of 0.5 was assigned by Rosetta in Hydrus, and was used in this analysis. Table 4-1 presents the hydraulic parameters generated by Rosetta for the general fill matrix. The saturated hydraulic conductivity calculated by Rosetta was 1.35×10^{-4} cm/sec. This value is near the middle of the range presented in Freeze and Cherry (1979) for silty sand. It is near the high end of the reported glacial till range and lower than the clean sand and gravel ranges reported by the same reference.

Although the actual value(s) of hydraulic conductivity are not known for the proposed future embankment, the value calculated by Rosetta is reasonable for the anticipated texture and density of the general fill *matrix*, and is consistent with the active/inactive matrix method of modeling unsaturated flow in the embankment. Experience with testing *saturated* hydraulic conductivity of soils similar in texture to the modeled fill suggests that the Rosetta-calculated value is too low for the bulk (matrix plus gravels) general embankment fill; however, the reason for this discrepancy is the presence of large pores associated with gravels. Large pores associated with gravel deposits dominate saturated flow but can be reasonably assumed inactive under most unsaturated flow conditions because:

- the fill should remain unsaturated except in extreme conditions, and therefore unsaturated flow should predominate,
- large diameter pores associated with gravels will be the first to desaturate as drying occurs,
- over the course of the flow path, water in saturated pores will be absorbed into the finer pores due to matric tension,
- percolation theory (Silliman and Wright, 1988) suggests that continuous paths of finer pores within the matrix will exist throughout the embankment at the modeled texture (it also predicts continuous coarse pore paths which would be predominant in saturated flow),
- it was not feasible for this project to characterize soil moisture retention characteristics of gravels

This representation should be accurate for classical unsaturated flow modeling used by Hydrus and for nearly all other unsaturated flow prediction methods. However, it does not account for the observation that "fingering" of flow can occur in coarse soils under very wet conditions. Fingering occurs when saturation builds-up at one location and then rapidly drains downward through large connected pores in a saturated finger. Such fingering flow will only occur during recharge events when the ground surface, or a subsurface soil zone, becomes saturated. If fingering flow occurs because of a saturated ground surface, this modeling approach will underestimate infiltration. The likelihood of underestimating infiltration has increased relative to the original modeling approach reported on August 8 2001 because of the more variable moisture conditions predicted using hourly precipitation data and the explicit calculation of volumes that will runoff. If fingering flow occurs for substantial distances within the body of the fill, the Hydrus

model will overestimate groundwater travel times between ground surface and the water table. The likelihood of overestimating vertical groundwater travel times for the wettest conditions is also somewhat increased relative to the modeling reported on August 8 2001 because of the more variable moisture conditions used in the current assessment.

4.4 Spatial Discretization of Hydrus Models

As described in Section 4.1, Hydrus models were set up to simulate a total of twelve vertical profiles for the proposed fill. Eight different thickness simulations were run for Miller Creek fill and four different thickness simulations were run for Walker Creek fill. Model runs for a given basin differ in fill thickness only. Separate runs were required for the two basins because slightly different IA/PA ratios led to different effective recharge rates.

Nodes representing the land surface were specified flux boundaries. The bottom two nodes were assigned the "water table" boundary condition, which is a constant head boundary equal to elevation head, simulating saturated conditions beneath the embankment fill. Time-series data for flow rates (specific discharge) exiting the bottom of the model domain at the water table boundary nodes were extracted and used as input to the Slice models.

Discretization of the soil profile emphasized detail within the top and bottom six inches of the column to accommodate dramatic changes in recharge and flow. Finer detail within these portions of the soil column improves accuracy in variable flow and water balance calculations as well as improving numerical model performance. Cell size increased in from a minimum of 0.01 cm at the top of the soil profile to about 0.3 inch at a depth of 6 inches. At a depth of 6 inches cells were a constant 6 inches down to 6 inches above the water table, at which point the change in intervals reverted back to 5 percent differences.

4.5 Temporal Discretization

Daily stress periods were used, and daily effective matrix recharge estimates were applied to the top of each model. Model timesteps were automatically optimized by Hydrus, and were typically on the order of 0.10 days. The models were run for water years 1984 through 1994, with only the last four water years comprising the test period. Output from the initial six years was examined visually to assure that residual effects from the initial conditions (uniform moisture) were not present during the 1991-1994 test period.

4.6 Results

Figure 4-1 shows eight daily outflow graphs for the Miller Creek basin fill over the test period. The outflow graphs represent the daily average flow of water to the embankment drain layer (or the water table within the drain) for any one of eight modeled fill thickness intervals. Figure 4-2 presents comparable results for the Walker Creek fill. Fill thickness

intervals correspond with the range of fill geometries occurring in each basin as presented in Figure 2-1. Effective recharge into the fill (Hydrus model input) is not shown on these figures because the input is very "spikey" and the lines obscure the model results. Nonetheless, the character of the effective recharge input can be inferred from the 10-foot-thick-fill output, which is only slightly damped and delayed relative to the input.

Figures 4-1 and 4-2 show that the recharge below the root zone is predicted to be lagged and dampened as a function of the thickness of the fill. Lagging causes the arrival of the recharge pulse to be delayed from its introduction at the land surface to its arrival at the bottom of the fill. Dampening causes a reduction in the overall range of flux in the deeper fill. Lagging and dampening both increase with increasing fill thickness and decrease with increasing annual recharge. These effects on the timing of recharge affect the arrival of flow to the top of the slice model (i.e., to the water table in the embankment drainage layer), and ultimately the arrival of baseflow to streams bordering the study area.

The Hydrus models were marginally stable during times of maximum wetness. During some model time steps, saturation was indicated at land surface as would be predicted by the runoff analysis. Hydrus was setup to permanently exclude water that would not enter the land surface at each time step. Water thus excluded was removed from the model and accounted for as a small additional component of runoff (RO3 on Table 3-1). Also, to increase model stability, recharge during one event was artificially lowered, with the removed water accounted as a fourth runoff component (RO4 on Table 3-1). RO3 and RO4 sum to less than 0.3 percent of total water and are insignificant. The runoff time series provided HSPF modelers as a product of this work included all runoff components.

Quality assurance review included comparison of total outflow between runs, and comparison of total inflow to the average total outflow. All model runs had the same total outflow to within 3 percent and 1.6 percent, respectively, for Miller and Walker Creek Hydrus models. For the Miller Creek models, total effective recharge was about 1.4 percent less than the average total outflow, likely as a result of lower storage at the end of the simulation than at the beginning. For the Walker Creek Hydrus models, total effective recharge was about 0.1 percent less than the average total outflow (for the same reason).

Hydrus erroneously predicted zero flux at the bottom boundary in a handful of time steps. These time steps are apparent on Figures 4-1 and 4-2. Review of the time series output and the good mass balance indicates that errors introduced are spurious and not significant.

5. Modeling Saturated Flow Beneath the Embankment Fill

Three simple finite difference slice models were developed to simulate lateral and vertical groundwater flow within the drain layer and existing soils below the embankment. Slice configurations were based on subsurface data described in available geotechnical and

hydrogeologic reports and from the pre-fill and "built" topography of the third runway area as supplied by Parametrix and the Port. Slice alignments were located based on the availability of subsurface data and are considered to describe the range of hydrogeologic and fill conditions that exist in the embankment area.

The slice models were used to accumulate recharge in the shallow water table aquifer and move it downgradient to the Miller Creek or Walker Creek wetlands under "built" conditions. Slice 1 was originally developed for the Ecology study (Pacific Groundwater Group, 2000). It was re-applied for this low-flow analysis using daily recharge data for 1984 through 1994 and a more representative runway configuration, but otherwise remained unchanged. Slices 2 and 3 were developed for the low flow analysis using new interpretations of existing hydrogeologic and fill data. The three different versions of the model were constructed to represent a range of conditions that exist within the fill embankment. The slice models are a simplification of subsurface conditions within each hydrogeologic cross section. **Figures 5-1 through 5-3** present simplified cross sections of the slice models used in this study. Slice locations are shown on **Figure 2-1**. Slice 2 was modified slightly from the version reported on August 8 2001 to include the 1998 (Phase 1) fill.

The slice models are based on a quasi-two-dimensional finite-difference formulation of the partial differential equation describing transient groundwater flow through a saturated medium. Model cells were only connected to laterally adjacent neighbors as opposed to overlying or underlying cells – thus the quasi-two-dimensional nature of the model. Each model cell can contain up to three different "soil layers", differing in thickness and hydraulic conductivity. The bottom elevation of each cell is defined by the top of the till layer, and downward flow through the till was simulated. For each cell, the model also specified a uniform specific yield of 30 percent. Recharge for each stress period (day) was derived for each cell from Hydrus output for the appropriate overlying fill thickness. The model assumes unconfined flow (variable transmissivity) under horizontal gradients defined by head differences between adjacent cells. The model was implemented in a Microsoft Excel spreadsheet, using direct (explicit) methods to solve the finite-difference equation. Details of the slice model input and functions are described further in Appendix E of the Ecology study report (Pacific Groundwater Group, 2000).

Downward flow through till was calculated using Darcy's equation, a uniform hydraulic conductivity of 4×10^{-3} ft/day (1.4×10^{-6} cm/sec), a uniform thickness of 10 feet, and a model-calculated gradient. To calculate the gradient, the head of groundwater above the till was calculated by the model, and head at the bottom of the till was considered to be one of three values. Groundwater head at the bottom of the till was assumed equal to the elevation of that contact where groundwater in the underlying Qva aquifer was expected to be unconfined (see **Figures 5-1 through 5-3**). This condition prevailed in the eastern portions of Slices 1 and 2, and throughout Slice 3. Groundwater head below the till was considered to be equal to groundwater head above the till where the conceptual model predicted highly confined conditions. This "no vertical flow" condition was actually implemented in the model by assigning a zero hydraulic conductivity to the till where

highly confined conditions were expected. That condition prevailed in the western lowland portions of Slices 1 and 2. Groundwater head at the bottom of the till, in locations of intermediate confinement of Qva groundwater, was assigned a value equal to the elevation of the mid-point of the till.

5.1 Cross Section 1 and Slice 1

This cross section is located through the thickest portion of the fill embankment with a fill thickness of up to 160 feet (Figure 2-1). A simplified cross section showing Slice 1 is presented in Figure 5-1. Slice 1 is located at the same location as the original slice model developed by PGG in the Ecology study. Hydrogeologic conditions were defined by eight subsurface explorations located along the 1,320-foot slice alignment. Fill located behind the West MSE wall was modeled using Slice 1.

The geometry and material types represented in the cross section of Figure 5-1 were used to construct the Slice 1 model. Tables 5-1 and 5-2 present Slice 1 model cell parameters. Because the removed portion of the HSPF model does not include the steep slopes of the embankment fill, results from Slice 1 were extracted from the portion east of cell 43 ("active model cells").

5.2 Cross Section 2 and Slice 2

Slice 2 is located through the northern portion of the fill embankment near the northern end of the third runway (Figure 2-1). A simplified cross section showing Slice 2 is presented in Figure 5-2. The slice is located to represent an intermediate fill thickness of up to 100 feet thick and crosses one taxiway in addition to the third runway. Slice 2 was developed from a generalized hydrogeologic cross section originally created by Hart Crowser through the northern toe of the fill embankment (see Section A-A' of Hart Crowser, 1999a) with supplemental information from more recent borings and shallow test pits (Hart Crowser, 2000a). The slice location is based on availability of suitable subsurface data with seven explorations located near the 1,420-foot slice alignment. Slice 2 represents subsurface conditions for the bulk of Miller Creek embankment fill.

The geometry and material types represented in the cross section of Figure 5-2 were used to construct the Slice 2 model. Tables 5-3 and 5-4 present Slice 2 model cell parameters. Because the removed portion of the HSPF model does not include the steep slopes of the embankment fill, results from Slice 2 were extracted from the portion east of cell 38 ("active model cells").

5.3 Cross Section 3 and Slice 3

Slice 3 is located immediately north of the South MSE wall (Figure 2-1). A simplified cross section showing Slice 3 is presented in Figure 5-3. A fill thickness of up to 40 feet occurs in the western end of this slice. The slice location was chosen through fill of intermediate thickness for the Walker Creek fill and minimal thickness for the Miller

Creek fill. Although this slice does not completely describe the variety of fill thicknesses in Walker Creek basin, the thicker portion of the fill is of small areal extent and does not justify an additional slice model. Slice 3 is partially based on a generalized hydrogeologic cross section originally created by Hart Crowser through the northern end of the South MSE wall study area (see Section E-E' of Hart Crowser, 2000b). The hydrogeologic interpretation for this slice has been modified using geotechnical data (Hart Crowser, 2000a), existing and "built" topography, and available till mapping data (AESI, 1999). Eight subsurface explorations occur along the 625-foot slice alignment.

The geometry and material types represented in the cross section of **Figure 5-3** were used to construct the Slice 3 model. **Tables 5-5 and 5-6** present Slice 3 model cell parameters. Because the removed portion of the HSPF model does not include the steep slopes of the embankment fill, results from Slice 3 were extracted from the portion east of cell 25 ("active model cells").

5.4 Individual Slice Model Results

Figures 5-4 through 5-6 present individual Slice model results for Slices 1 through 3 for water years 1991 through 1994. Results are presented as daily time series plots for three Slice model terms: Qvr/drain outflow flow downward through till, and recharge to the drain layer from the fill. The Qvr/drain outflow term is lateral groundwater flow at the western edge of the fill embankment discharging through the shallow (Qvr) aquifer and the constructed drain layer. The Qvr/drain outflow term is extracted from the westernmost "active" cell in the slice, and represents subsurface flow towards downgradient receiving waters. Downward flow through till and recharge to the drain layer from the fill are summed for all active cells in the slice. Downward flow through the till represents vertical drainage to the deeper (Qva) aquifer below the till. Recharge to the drain from the fill is obtained by summing Hydrus output as it varies along the slice due to the varying thickness of overlying fill. Model results represent flow for a one-foot-wide slice of the embankment with units reported in cubic feet per day, per foot of width (ft³/d or ft³/d-ft).

Results vary substantially between the slices and indicate that a complex set of factors control the relationship between input (recharge to the drain) and output (Qvr/drain outflow and downward flow through till):

- The timing of recharge to the drain layer is controlled by the type and thickness of fill in the slice. More uniform fill thickness in Slice 3 results in more seasonal variability of recharge to the drain layer compared to Slices 1 and 2.
- Differences in the variability of Qvr/drain outflow shows that the presence of Type 1 fill causes output to be nearly as variable as input on Slice 1 where Type 1 fill exists, and to be rather smooth for the other slices where Type 1 fill is assumed to not exist. Transition of flow from wholly within the moderately-transmissive Qvr during dry and moderate periods, to a combination of the Qvr and the highly-transmissive drain layer during wet periods, may also contribute to this effect at Slice 1. The spikiness of modeled Slice 1 Qvr/drain outflow is likely greater than would actually occur.

- Longer flow-length paths and lower gradients within the Qvr and drain layer should contribute to longer horizontal travel time delays. However, longer flow lengths and steeper gradients in Slices 1 and 2 compare to shorter lengths and gentler gradients in Slice 3. This combination of gradient and flow paths for the two sets of slices causes horizontal travel time delays are more similar between the slices than might otherwise occur.
- Downward flow through the till is seasonal due to changes in aquifer saturation. Downward flow through till is also greater on average than Qvr/drain outflow, and is sensitive to till permeability. Qvr/drain outflow exceed downward flow through till during intense recharge events at Slice 1 (through Type 1 fill), and during some seasonal maxima at Slices 1 and 3.
- Seasonal maxima in Qvr/drain outflow are lagged more in dry years than in wet years (this be more a result of vertical flow delays than lateral flow delays).

Quality assurance review of Slice model results included comparison of total inflow, outflow and change in storage between runs. In all cases, the mass balance error in this comparison was less than one percent.

5.5 Method for Integrating Slice Results Over Entire Fill Areas

Groundwater discharge quantities for Miller and Walker Creeks were calculated by multiplying unit-width flow quantities from representative Slice model output by an effective basin width (EBW). This process integrates the slice model results over the entire basin. The EBW represents an idealized length over which groundwater within the embankment will discharge to the respective downgradient receiving waters. EBWs were measured (or calculated) parallel to the long axis of embankment fill, an orientation perpendicular to the slice models and expected groundwater flow lines. EBWs are associated with each Slice model and depend on the width of the basin with characteristics similar to the slice (i.e., thickness and lateral extent). For instance, the entire Walker Creek basin is best represented only by Slice 3 because the embankment fill in this basin is relatively narrow and has limited thickness variation (typically less than 40 feet thick). Walker Creek is therefore modeled by Slice 3 only and the results are integrated over the basin using a single EBW. In contrast, Miller Creek is represented by a combination of Slices 1, 2, and 3 because of variable fill geometries that occur in this basin (fill thickness ranging up to 160 feet over a variety of fill lengths). **Figure 2-1** presents the approximate segments of the Miller and Walker Creek basins that are represented by each of the Slice models. A summary of effective basin widths is presented in **Table 5-7**.

The derivation of EBWs is discussed in the following sections followed by a summary of the integrated flow results for each basin.

5.6 Effective Basin Width for Walker Creek

The EBW for Walker Creek basin was calculated to maintain a water balance for the modeled fill area (MFA) measured for the basin, where $MFA=IA+FS+OPA$ as defined in Section 2.3. To maintain a water balance, the integrated area of the slice models must equal the MFA of the basin. When this condition is met, effective recharge for the basin should equal the effective recharge of the integrated slice model results. In the Walker Creek Basin, an EBW of 2,084 feet was calculated based on a Slice 3 length of 350 feet and an MFA of 729,547 square feet.

5.7 Effective Basin Width for Miller Creek

The total EBW for Miller Creek basin is comprised of four segments that are represented by Slices 1, 2 and 3 (Figure 2-1). Multiple slices were used to describe groundwater flow to Miller Creek because of the variable fill width and fill thickness in this basin. Similar to Walker Creek, the EBW for Miller Creek was adjusted to maintain a water balance for the MFA measured previously for the basin. That is, the Miller Creek basin fill area (and therefore basin recharge area) defined by the calculated total EBW was the same as the MFA used for Hydrus and Slice modeling. Because the average fill length (east-west) is considerably less than the Slice 2 modeled fill length (east-west) used to represent the north and south ends of the basin, the Slice 2 EBW was reduced to achieve the desired MFA.

The EBW for the segment represented by Slice 1 adjacent to the West MSE wall was assigned a value of 1,600 feet based on map measurements (Figure 2-1). The fill length over this reach is relatively uniform at approximately 1,000 feet and is close to the 1,050-foot Slice 1 model length. The map-measured length was therefore considered representative for this reach of the basin and the map length was adopted as the EBW.

The Miller Creek basin reach located north of the West MSE wall is represented by Slice 2. The northeastern corner of the runway fill has an irregular shape where the actual fill length (east-west) is less than the Slice 2 model length. The basin reach immediately south of the West MSE wall is also represented by Slice 2. The combined map width of the two Miller Creek reaches represented by Slice 2 is approximately 3,700 feet. However, to maintain a water balance for the basin, the combined EBW for Slice 2 segments was reduced relative to map widths shown on Figure 2-1. The combined EBW for Slice 2 segments was adjusted to 2,699 feet to maintain the water balance. By adjusting the Slice 2 EBW in this manner, an MFA of 5,001,390 square feet was calculated which is approximately equal to the GIS-measured MFA of 5,001,205 square feet.

The southern reach of the Miller Creek basin is represented by Slice 3 where the fill is relatively thin and narrow (east-west). The EBW for this reach of Miller Creek was assigned as the map-estimated length 930 feet. The actual fill length (east-west) of 340

feet is closely approximated by the modeled slice width of 350 feet. The map-measured EBW is therefore considered representative for this reach of the basin as mass balance is maintained.

5.8 Integrated Flow Estimates for Walker Creek Fill

Integrated estimates of Qvr/drain outflow and downward flow through till for the Walker Creek fill area for water years 1991 through 1994 are presented in Figure 5-7. Also shown is the effective recharge input to the Hydrus model. Thus, Figure 5-7 indicates changes in timing of flows resulting from both vertical and lateral groundwater travel. Integrated flows for Walker Creek are the product of the 2,084-ft EBW discussed in Section 5.6 and the model results for Slice 3 discussed in Section 5.4. Figure 5-7 shows that the timing and magnitude of Qvr/drain outflow varies seasonally, with maximum flows predicted during spring or early summer and minimum flows predicted during winter. Estimated annual maximum Qvr/drain outflows through the fill range between about 3,500 cubic feet per day (cfd) in water year 1991 with a peak flow predicted in late March, and about 1500 cfd in 1994 with a peak flow predicted in late April. Estimated annual minimum Qvr/drain outflows are predicted to occur between October and December, with some years experiencing a period of no flow from the Qvr/drain. High flows lag behind the onset of recharge season because time is required for unsaturated flow to transport recharge through the embankment fill and because time is required for lateral flow from areas of recharge to the downgradient end of the model.

Integrated till seepage rates for the Walker Creek basin fill increase rapidly in November or December when the downward moving recharge within the embankment reaches the water table. This effect is accentuated in the Walker Creek case because of the narrow range of fill thicknesses. After a long period of nearly constant discharge following the sudden rise, a gradual decline occurs in late summer. Seepage through the till is estimated to occur at maximum annual rates of 2200 to 2400 cfd for the four year period shown in Figure 5-7. Downward flow through the till is predicted to occur at some rate over the entire year.

Quality assurance review included comparison of total inflow to total outflow. For Walker Creek, integrated outflow was about 4 percent greater than total effective recharge for the 11-year test period, likely as a result of lower groundwater storage at the end of the simulation than at the beginning, and/or the coarseness of slice model cell resolution which prevented exact replication of the GIS-measured IA and PA.

5.9 Integrated Flow Estimates for Miller Creek Fill

Integrated estimates of Qvr/drain outflow and downward flow through till for the Miller Creek Fill area for water years 1991 through 1994 are presented in Figure 5-8. Integrated flows are the sum of the products of the effective basin widths discussed in Section 5.7 and the model results for Slices 1, 2, and 3 presented in Section 5.4. Figure 5-8 shows relatively constant Qvr/drain outflow rates from the Miller Creek fill embankment,

punctuated by spikes during rainstorms, and a seasonal maximum in June and July of the relatively wet year of 1991. The spikiness is to some extent a modeling artifact of the infinite permeability assumed for Type 1 fill. Actual flow rates would likely be steadier. Estimated annual maximum Qvr/drain outflows range from about 18,000 cfd in April of 1991 to about 8,000 cfd in late-July of 1994 following a year of low recharge.

Integrated downward flow through the till for the Miller Creek basin fill is relatively constant, but with a smooth seasonal pattern. Model estimates of flow range from about 16,000 to 7,000 cfd. Maxima are in April to June. Minima are in October and November.

Quality assurance review included comparison of total inflow to total outflow. For Miller Creek, integrated outflow was 3 percent greater than total effective recharge for the 11-year test period, likely as a result of lower groundwater storage at the end of the simulation than at the beginning, and/or coarseness of cell size resolution in the slices which prevented exact replication of the GIS-measured IA and PA.

5.10 Use of Integrated Flow Estimates

Integrated flow estimates for Miller and Walker Creek basins were transmitted to Parametrix and Aqua Terra for use in HSPF models of Miller and Walker Creeks. Time series of total daily discharge (volume per day) from above the till (Qvr/drain outflow), and total daily discharge through the till (downward flow through the till) were provided. In addition, total runoff as an hourly time series was provided. All volumes were for the MFAs within the Miller Creek and Walker Creek basins. Parametrix and Aqua Terra used the flow estimates developed in this modeling study as part of a low-stream-flow impact evaluation.

6. References

Associated Earth Sciences, Inc. (AESI), 1999. Seattle-Tacoma International Airport Ground Water Study – Model Boundary Presentation. Unpublished figures and cross sections prepared for The Port of Seattle dated October 15, 1999.

Brascher, Joe, Aqua Terra, personal communication regarding HSPF-derived recharge data for 1984 through 1994, May 17, 2001.

Earth Tech, 2000, Seattle-Tacoma Airport Master Plan Update Low Streamflow Analysis, December, 2000. Unpublished consulting report prepared for the Port of Seattle.

Freeze R. A. and J.A. Cherry, 1979, Groundwater, Prentice-Hall, Englewood Cliffs, New Jersey

Hart Crowser, Inc., 1999. Subsurface Conditions Data Report 404 Support Third Runway Embankment. Unpublished consulting report prepared for HNTB and The Port of Seattle dated July 1999.

Hart Crowser, Inc., 2000a. Draft Subsurface Conditions Data Report Additional Field Explorations and Advanced Testing, Third Runway Project Sea-Tac International Airport. Unpublished consulting report prepared for HNTB dated September 5, 2000.

Hart Crowser, Inc., 2000b. Draft Subsurface Conditions Data Report South MSE Wall and Adjacent Embankment Third Runway Project Sea-Tac International Airport. Unpublished consulting report prepared for Port of Seattle and HNTB dated April 7, 2000.

Mualem, Y. 1976. A New Model for Predicting the Hydraulic Conductivity of Unsaturated Porous Media, *Water Resources Research*, 12(3), 513-522.

Pacific Groundwater Group, 2000. Sea-Tac Runway Fill Hydrologic Studies Report, Unpublished consulting report prepared for the Department of Ecology.

Pacific Groundwater Group, 2001a. Memorandum entitled Model Area and Hydrus Results – Draft Interim Deliverables, prepared for Keith Smith, Port of Seattle dated June 25, 2001.

Pacific Groundwater Group, 2001b. Port of Seattle Sea-Tac Third Runway Embankment Fill Modeling, August 8, 2001.

Parametrix, 2000. Comprehensive Stormwater Management Plan, Master Plan Update Improvements, Seattle-Tacoma International Airport, December, 2000.

Parametrix, 2001. Low Flow Analysis, Flow Impact Offset Facility Proposal, Port of Seattle. July, 2001

Simunek, J., Senjna, M., van Genuchten, M. Th., 1999. Hydrus-2D/Meshgen-2D - Simulating Water Flow and Solute Transport in Two-Dimensional Variably Saturated Media, Version 2.0 dated April 1999, U.S. Salinity Laboratory, USDA/ARS. Distributed by International Groundwater Modeling Center.

Silliman S.E., and A.L. Wright, 1988, Stochastic Analysis of Paths of High Hydraulic Conductivity in Porous Media, *Water Resources Research*, Vol. 24, No. 11.

van Genuchten, M. Th., 1980. A Closed Form Equation for Predicting the Hydraulic Conductivity of Unsaturated Soils, *Soil Science Society of America Journal*, 44, 892

TABLES

Table 2-1
Summary of Areas Modeled by Hydrus-Slice

	Miller Creek Basin		Walker Creek Basin	
	square feet	acres	square feet	acres
Filter Strip Area (FS)	1,456,854	33.44	353,133	8.11
Other Pervious Fill Area (OPA)	1,746,649	40.10	99,342	2.28
Runway and Taxiway Impervious Area (IA)	1,797,702	41.27	277,072	6.36
Total Modeled Fill Area (MFA) in Basin	5,001,205	114.81	729,547	16.75
IA/total pervious area	0.56		0.61	
FS/PA	0.45		0.78	
IA/total Area	0.36		0.38	

11/27/01

Tables_2-1_4-1_5-7_for_Report.xls, Table 2-1

AR 019988

**Table 3-1
Summary of Water Volumes**

	Water Available to Filer Strip	Water Available to OPA	Runoff from Filer Strip (RO1)	Runoff from Other Pervious Area (RO2)	Water excluded by Hydus (RO3)	Water artificially removed from Hydus to promote stability (RO4)	Total Runoff	Total Infiltration
Miller Creek Modeled Fill Area (ft3)	69,006,366	29,689,341	19,625,881	1,652,948	220,585	0	21,499,415	77,198,293
Miller Creek Modeled Fill Area (percent of total water)	70%	30%	20%	2%	0%	0%	22%	78%
Walker Creek Modeled Fill Area (ft3)	12,821,485	1,888,604	2,650,317	94,013	40,091	8,686	2,793,108	11,716,981
Walker Creek Modeled Fill Area (percent of total water)	88%	12%	18%	1%	0%	0%	19%	81%

Table 4-1
Summary of Hydraulic Parameters Used for Fill Matrix in the Hydrus-2D Model

Sand Fraction of matrix	63%
Silt Fraction of matrix	37%
Clay Fraction of matrix	0
Saturated Volumetric Water Content of matrix	0.25
Residual Volumetric Water Content of matrix	0.02
"alpha" (1/cm)	0.088
"N"	1.35
Saturated Hydraulic Conductivity (cm/sec) of matrix	1.35×10^{-4}

11/27/01

Tables_2-1_4-1_5-7_for_Report.xls, Table 4-1

AR 019990

**Table 5-1
Slice 1 Model Parameters for Different Cell Types**

Model Parameters for Cells Types

	Cell Type 1	Cell Type 2	Cell Type 3
Surficial Soil	removed	removed	removed
Aquifer Materials	fill	outwash stringers	peat & outwash
Land Cover	embankment	embankment	embankment
Wetland/Upland	upland	upland	wetland
Bottom Layer Hydraulic Conductivity (ft/d)	300	6	2.65
Top of Bottom Layer (ft above till)	4	7.5	7.5
Middle Layer Hydraulic Conductivity (ft/d)		300	300
Top of Middle Layer (ft above till)		11.5	11.5
Upper Layer Hydraulic Conductivity (ft/d)			
Top of Upper Layer (ft above till)			
Maximum Saturated Thickness (ft)		11.5	11.5
Gradient of Top of Till (ft/ft)	18.75%	18.75%	3.60%
Fill Thickness Hydraulic Conductivity (ft/d)	300	108.2608698	106.076087
Maximum Subsurface Flow (cfd)	225	233.4375	43.9155
Maximum Downgradient Flow (cfd)	233.4375	43.9155	124.2
Cell Length (ft)	25	25	25
Specific Yield	0.3	0.3	0.3
Maximum Storage (cubic ft)	30	86.25	86.25
Bottom Layer Storage (cubic ft)	30	56.25	56.25

NOTE: All values are for a vertical slice of 1-foot width.

Model Constants

Till Thickness (ft)	10
Till Permeability Beneath Uplands (ft/d)	0.004
Till Permeability Beneath Wetlands (ft/d)	0
Outwash Permeability (ft/d)	6
Peat Permeability (ft/d)	1
Percent Outwash in Peaty Aquifer	0.33
Peaty Aquifer Permeability (ft/d)	2.65
Drain Material Permeability (ft/d)	300
Till Derived Soil Permeability (ft/d)	4
Outwash Derived Soil Permeability (ft/d)	4
Wetland Surficial Soil Permeability (ft/d)	1
Minimum Saturation Considered for h and T (ft)	0.0001

Time Stepping

user defined model timestep (d)	0.1
---------------------------------	-----

Table 5-2
 Slice 1 Model Cell Parameters

Cell ID	Distance from Outlet	Top of Trench Elevation	Cell Length (ft)	Cell Type	Trench Permeability (ft/d)	Head at Bottom of Trench	Maximum Subsurface Outflow (cfd)	Specific Yield	Maximum Storage (cf)	Fill Material	Embankment Thickness (ft)	Modelled "Effective" Embankment Thickness (ft)
1	1137.5	385.0438	25	1	0.004	375.0438	225	0.3	30	Type 2	3	0
2	1112.5	380.3563	25	1	0.004	370.3563	225	0.3	30	Type 2	7	10
3	1087.5	375.6688	25	1	0.004	365.6688	225	0.3	30	Type 2	11	10
4	1062.5	370.9813	25	1	0.004	360.9813	225	0.3	30	Type 2	14	10
5	1037.5	366.2938	25	1	0.004	356.2938	225	0.3	30	Type 2	19	10
6	1012.5	361.6063	25	1	0.004	351.6063	225	0.3	30	Type 2	24	-99 laxway, no recharge
7	987.5	356.9188	25	1	0.004	346.9188	225	0.3	30	Type 2	27	-99 laxway, no recharge
8	962.5	352.2313	25	1	0.004	342.2313	225	0.3	30	Type 2	32	-99 laxway, no recharge
9	937.5	347.5438	25	1	0.004	337.5438	225	0.3	30	Type 2	35	-99 laxway, no recharge
10	912.5	342.8563	25	1	0.004	332.8563	225	0.3	30	Type 2	40	50
11	887.5	338.1688	25	1	0.004	328.1688	225	0.3	30	Type 2	44	-99 laxway, no recharge
12	862.5	333.4813	25	1	0.004	323.4813	225	0.3	30	Type 2	49	50
13	837.5	328.7938	25	1	0.004	318.7938	225	0.3	30	Type 2	54	-99 laxway, no recharge
14	812.5	324.1063	25	1	0.004	314.1063	225	0.3	30	Type 2	57	-99 laxway, no recharge
15	787.5	319.4188	25	1	0.004	309.4188	225	0.3	30	Type 2	60	-99 laxway, no recharge
16	762.5	314.7313	25	2	0.004	304.7313	233.4375	0.3	86.25	Type 2	64	70
17	737.5	310.0438	25	2	0.004	299.0438	233.4375	0.3	86.25	Type 2	69	74
18	712.5	305.3563	25	2	0.004	294.3563	233.4375	0.3	86.25	Type 2	74	70
19	687.5	300.6688	25	2	0.004	289.6688	233.4375	0.3	86.25	Type 2	78	70
20	662.5	295.9813	25	2	0.004	284.9813	233.4375	0.3	86.25	Type 2	84	90
21	637.5	291.2938	25	2	0.004	280.2938	233.4375	0.3	86.25	Type 2	90	90
22	612.5	286.6063	25	2	0.004	275.6063	233.4375	0.3	86.25	Type 2	98	90
23	587.5	281.9188	25	2	0.004	270.9188	233.4375	0.3	86.25	Type 2	101	110
24	562.5	277.2313	25	2	0.004	266.2313	233.4375	0.3	86.25	Type 2	105	110
25	537.5	272.5438	25	2	0.004	261.5438	233.4375	0.3	86.25	Type 2	111	-99 runway, no recharge
26	512.5	267.8563	25	2	0.004	256.8563	233.4375	0.3	86.25	Type 2	116	-99 runway, no recharge
27	487.5	263.1688	25	2	0.004	252.1688	233.4375	0.3	86.25	Type 2	120	-99 runway, no recharge
28	462.5	258.4813	25	2	0.004	247.4813	233.4375	0.3	86.25	Type 2	125	-99 runway, no recharge
29	437.5	253.7938	25	2	0.004	242.7938	233.4375	0.3	86.25	Type 2	128	-99 runway, no recharge
30	412.5	249.1063	25	2	0.004	238.1063	233.4375	0.3	86.25	Type 2	132	-99 runway, no recharge
31	387.5	244.4188	25	2	0.004	233.4188	233.4375	0.3	86.25	Type 2	138	-99 runway, no recharge
32	362.5	239.7313	25	2	0.004	228.7313	233.4375	0.3	86.25	Type 2	142	-99 runway, no recharge
33	337.5	235.0438	25	2	0.004	224.0438	233.4375	0.3	86.25	Type 2	147	-99 runway, no recharge
34	312.5	230.3563	25	5	0	222.25	43.9155	0.3	86.25	Type 2	148	-99 runway, no recharge
35	287.5	225.6688	25	5	0	221.36	43.9155	0.3	86.25	Type 2	148	150
36	262.5	220.9813	25	5	0	219.55	43.9155	0.3	86.25	Type 2	148	150
37	237.5	216.2938	25	5	0	218.65	43.9155	0.3	86.25	Type 2	148	150
38	212.5	211.6063	25	5	0	217.75	43.9155	0.3	86.25	Type 2	148	150
39	187.5	206.9188	25	5	0	216.85	43.9155	0.3	86.25	Type 2	148	150
40	162.5	202.2313	25	5	0	215.95	43.9155	0.3	86.25	Type 2	146	0
41	137.5	197.5438	25	5	0	215.05	43.9155	0.3	86.25	Type 2	146	0
42	112.5	192.8563	25	5	0	214.15	43.9155	0.3	86.25	Type 2	145	0 not included in mass balance
43	87.5	188.1688	25	5	0	213.25	43.9155	0.3	86.25	Type 2	115	0 not included in mass balance
44	62.5	183.4813	25	5	0	212.35	43.9155	0.3	86.25	Type 2	7	0 not included in mass balance
45	37.5	178.7938	25	5	0	211.45	43.9155	0.3	86.25	Type 2	7	0 not included in mass balance
46	12.5	174.1063	25	5	0	211.45	9999	0.3	86.25	Type 2	0	0

**Table 5-3
Slice 2 Model Parameters for Different Cell Types**

Model Parameters for Cells Types	cells 1-3, 8-9 Cell Type 1	cells 4-7 Cell Type 2	cells 10-13 Cell Type 3	cells 14-28 Cell Type 4	cells 29-43 Cell Type 5	cells 44-46 Cell Type 6
Surficial Soil	removed	removed	removed	removed	removed	removed
Aquifer Materials	outwash stringers	outwash stringers	outwash stringers	outwash stringers	outwash stringers	outwash stringers
Land Cover	embankment	embankment	embankment	embankment	embankment	embankment
Wetland/Upland	upland	upland	upland	upland	upland	upland
Bottom Layer Hydraulic Conductivity (ft/d)	6	6	6	6	6	6
Top of Bottom Layer (ft above till)	39.5	45	28.25	15	15	15
Middle Layer Hydraulic Conductivity (ft/d)	300	300	300	300	300	300
Top of Middle Layer (ft above till)	43.5	49	32.25	19	19	19
Upper Layer Hydraulic Conductivity (ft/d)						
Top of Upper Layer (ft above till)						
Maximum Saturated Thickness (ft)	43.5	49	32.25	19	19	19
Gradient of Top of Till (ft/ft)	0.0908	0.0908	0.0908	0.0908	0.0507	0.0165
Full Thickness Hydraulic Conductivity (ft/d)	33.03448276	30	42.46511628	67.89473684	67.89473684	67.89473684
Maximum Subsurface Flow (cfd)	130.4796	133.476	124.3506	117.132	66.403	21.285
Maximum Downgradient Flow (cfd)	133.476	65.403	21.285	117.132	65.403	21.285
Cell Length (ft)	30	30	30	30	30	30
Specific Yield	0.3	0.3	0.3	0.3	0.3	0.3
Maximum Storage (cubic ft)	391.5	441	290.25	171	171	171
Bottom Layer Storage (cubic ft)	355.5	405	254.25	135	135	135

NOTE: All values are for a vertical slice of 1-foot width.

Model Constants

Till Thickness (ft)	10
Till Permeability Beneath Uplands (ft/d)	0.004
Till Permeability Beneath Wetlands (ft/d)	0
Outwash Permeability (ft/d)	6
Peat Permeability (ft/d)	1
Percent Outwash in Peaty Aquifer	33%
Peaty Aquifer Permeability (ft/d)	2.65
Drain Material Permeability (ft/d)	300
Till Derived Soil Permeability (ft/d)	4
Outwash Derived Soil Permeability (ft/d)	4
Wetland Surficial Soil Permeability (ft/d)	1
Minimum Saturation Considered for h and T (ft)	0.0001
user defined model timestep (d)	0.1

11/27/01

Table 5-4
 Slice 2 Model Cell Parameters

Cell ID	Distance from Outlet	Top of TFI Elevation	Cell Length (ft)	Cell Type	TFI Permeability (ft/d)	Head at Bottom of TFI (ft)	Maximum Subsurface Outflow (c/d)	Specific Yield	Maximum Storage (cf)	Fill Material	Embankment Thickness (ft)	Modeled "Effective" Embankment Thickness (ft)	Notes
1	1385	371.9039	30	30	0.004	381.9939	130.4796	0.3	391.5	Type 1	0	0	0 drain only, no overlying fill
2	1335	369.0841	30	30	0.004	359.0941	130.4796	0.3	391.5	Type 1	0	0	0 drain only, no overlying fill
3	1305	366.1944	30	30	0.004	356.1944	130.4796	0.3	391.5	Type 2	0.5432	0	
4	1275	363.2946	30	2	0.004	353.2946	133.476	0.3	441	Type 2	1.3605	0	
5	1245	360.3948	30	2	0.004	350.3948	133.476	0.3	441	Type 2	2.1778	0	
6	1215	357.4951	30	2	0.004	347.4951	133.476	0.3	441	Type 2	9	10	
7	1185	354.5954	30	2	0.004	344.5954	133.476	0.3	441	Type 2	25	30	-99 taxway/unspec., no recharge
8	1155	351.6956	30	1	0.004	341.6956	130.4796	0.3	391.5	Type 2	32	30	
9	1125	348.7959	30	1	0.004	338.7959	130.4796	0.3	391.5	Type 2	39	39	-99 taxway/unspec., no recharge
10	1095	345.8961	30	3	0.004	335.8961	124.3506	0.3	290.25	Type 2	44	50	
11	1065	342.9964	30	3	0.004	332.9964	124.3506	0.3	290.25	Type 2	49	49	-99 taxway/unspec., no recharge
12	1035	340.0966	30	3	0.004	330.0966	124.3506	0.3	290.25	Type 2	51	50	
13	1005	337.1735	30	3	0.004	327.1735	124.3506	0.3	290.25	Type 2	53	50	-99 taxway/unspec., no recharge
14	975	334.2466	30	4	0.004	324.2466	117.132	0.3	171	Type 2	54	50	
15	945	331.3197	30	4	0.004	321.3197	117.132	0.3	171	Type 2	55	55	-99 taxway/unspec., no recharge
16	915	328.3928	30	4	0.004	318.3928	117.132	0.3	171	Type 2	58	50	
17	885	325.4658	30	4	0.004	315.4658	117.132	0.3	171	Type 2	59	50	
18	855	322.5389	30	4	0.004	312.5389	117.132	0.3	171	Type 2	62.6913	70	
19	825	320.0984	30	4	0.004	310.0984	117.132	0.3	171	Type 2	66.5809	70	
20	795	317.669	30	4	0.004	307.669	117.132	0.3	171	Type 2	70.4705	70	
21	765	315.2396	30	4	0.004	305.2396	117.132	0.3	171	Type 2	74.3001	70	
22	735	312.8102	30	4	0.004	302.8102	117.132	0.3	171	Type 2	77.8707	70	
23	705	310.3808	30	4	0.004	300.3808	117.132	0.3	171	Type 2	81.0024	-99	runway, no recharge
24	675	307.9514	30	4	0.004	302.9514	117.132	0.3	171	Type 2	84.1341	-99	runway, no recharge
25	645	305.5219	30	4	0.004	300.5219	117.132	0.3	171	Type 2	86.9	-99	runway, no recharge
26	615	303.0925	30	4	0.004	298.0925	117.132	0.3	171	Type 2	88.3	-99	runway, no recharge
27	585	300.6631	30	4	0.004	295.6631	117.132	0.3	171	Type 2	91.1885	-99	runway, no recharge
28	555	298.2337	30	4	0.004	293.2337	117.132	0.3	171	Type 2	92.2579	-99	runway, no recharge
29	525	295.8043	30	5	0	286.9078	85.403	0.3	171	Type 2	92.7119	-99	runway, no recharge
30	495	293.3749	30	5	0	284.4784	85.403	0.3	171	Type 2	93.1833	90	
31	465	290.9455	30	5	0	282.0489	85.403	0.3	171	Type 2	93.7422	90	
32	435	288.5161	30	5	0	279.6195	85.403	0.3	171	Type 2	94.301	90	
33	405	286.0867	30	5	0	277.1901	85.403	0.3	171	Type 2	94.8699	90	
34	375	283.6573	30	5	0	274.7607	85.403	0.3	171	Type 2	95.1136	90	
35	345	281.2279	30	5	0	272.3313	85.403	0.3	171	Type 2	96.0621	90	
36	315	278.7985	30	5	0	269.9019	85.403	0.3	171	Type 2	95.0105	90	
37	285	276.3691	30	5	0	267.4725	85.403	0.3	171	Type 2	94.9444	90	
38	255	273.9397	30	5	0	265.0431	85.403	0.3	171	Type 2	83.3566	-99	top of embankment and western edge of area receiving recharge
39	225	271.5103	30	5	0	262.6137	85.403	0.3	171	Type 2	71.7289	-99	no recharge
40	195	269.0809	30	5	0	260.1843	85.403	0.3	171	Type 2	60.1209	-99	no recharge
41	165	266.6515	30	5	0	257.7549	85.403	0.3	171	Type 2	48.5131	-99	no recharge
42	135	264.2221	30	5	0	255.3255	85.403	0.3	171	Type 2	37.6989	-99	no recharge
43	105	261.7927	30	5	0	252.8961	85.403	0.3	171	Type 2	27.0434	-99	no recharge
44	75	259.3633	30	6	0	250.4667	85.403	0.3	171	Type 2	16.388	-99	no recharge
45	45	256.9339	30	6	0	248.0373	85.403	0.3	171	Type 2	5.5944	-99	no recharge
46	15	254.5045	30	6	0	245.6079	85.403	0.3	171	Type 2	0	-99	no recharge

**Table 5-5
Slice 3 Model Parameters for Different Cell Types**

	Cell Type 1 removed outwash stringers embankment upland	Cell Type 2 removed outwash stringers embankment upland	Cell Type 3 removed outwash stringers embankment upland
Surficial Soil	6	6	6
Aquifer Materials	2.5	2.5	4.75
Land Cover	300	300	300
Wetland/Upland	3	6.5	8.75
Bottom Layer Hydraulic Conductivity (ft/d)			
Top of Bottom Layer (ft above till)			
Middle Layer Hydraulic Conductivity (ft/d)			
Top of Middle Layer (ft above till)			
Upper Layer Hydraulic Conductivity (ft/d)			
Top of Upper Layer (ft above till)			
Maximum Saturated Thickness (ft)	3	6.5	8.75
Gradient of Top of Till (ft/ft)	0.1711	0.0518	0.0518
Full Thickness Hydraulic Conductivity (ft/d)	55	186.9230769	140.4
Maximum Subsurface Flow (cfd)	28.2315	62.937	63.6363
Maximum Downgradient Flow (cfd)	28.2315	62.937	63.6363
Cell Length (ft)	25	25	25
Specific Yield	0.3	0.3	0.3
Maximum Storage (cubic ft)	22.5	48.75	55.625
Bottom Layer Storage (cubic ft)	18.75	18.75	35.625

NOTE: All values are for a vertical slice of 1-foot width.

Model Constants	10
Till Thickness (ft)	0.004
Till Permeability Beneath Uplands (ft/d)	0
Till Permeability Beneath Wetlands (ft/d)	6
Outwash Permeability (ft/d)	1
Peat Permeability (ft/d)	0.33
Percent Outwash in Peaty Aquifer	2.65
Peaty Aquifer Permeability (ft/d)	300
Drain Material Permeability (ft/d)	4
Till Derived Soil Permeability (ft/d)	4
Outwash Derived Soil Permeability (ft/d)	1
Wetland Surficial Soil Permeability (ft/d)	0.0001
Minimum Saturation Considered for h and T (ft)	
Time Stepping	0.1
user defined model timestep (d)	

**Table 5-6
Slice 3 Model Cell Parameters**

Cell ID	Distance from Outlet	Top of Tilt Cell Elevation	Cell Length (ft)	Cell Type	Tilt ability (ft/d)	Head at Bottom of Tilt	Maximum Outflow (cfs)	Specific Yield	Maximum Storage (cf)	Fill Material	Embankment Thickness (ft)	Modelled "Effective" Embankment Thickness (ft)	Notes
1	612.5	358.7677	25	1	0.004	358.7677	28.2315	0.3	22.5	Type 2	0	0	-99 drain only, no overlying fill, excluded from model via zero recharge
2	591.5	308.3032	25	1	0.004	358.3032	20.2315	0.3	22.5	Type 2	0	0	-99 drain only, no overlying fill, excluded from model via zero recharge
3	562.5	363.8638	25	2	0.004	353.8638	62.937	0.3	48.75	Type 2	0.8512	0	-99 excluded from model via zero recharge
4	537.5	362.6697	25	2	0.004	352.6697	62.937	0.3	48.75	Type 2	2.1642	0	-99 excluded from model via zero recharge
5	512.5	361.3756	25	2	0.004	351.3756	62.937	0.3	48.75	Type 2	3.6315	0	-99 excluded from model via zero recharge
6	487.5	360.0815	25	2	0.004	350.0815	62.937	0.3	48.75	Type 2	5.3445	0	-99 turnway, no recharge
7	462.5	358.7874	25	2	0.004	348.7874	62.937	0.3	48.75	Type 2	7.0575	0	-99 turnway, no recharge
8	437.5	357.4933	25	2	0.004	347.4933	62.937	0.3	48.75	Type 2	8.7705	0	-99 turnway, no recharge
9	412.5	356.1992	25	2	0.004	346.1992	62.937	0.3	48.75	Type 2	10.4835	0	-99 turnway, no recharge
10	387.5	354.9051	25	2	0.004	344.9051	62.937	0.3	48.75	Type 2	12.1965	0	-99 turnway, no recharge
11	362.5	353.6111	25	2	0.004	343.6111	62.937	0.3	48.75	Type 2	13.9095	0	-99 turnway, no recharge
12	337.5	352.3171	25	2	0.004	342.3171	62.937	0.3	48.75	Type 2	15.6225	0	-99 turnway, no recharge
13	312.5	351.0231	25	2	0.004	341.0231	62.937	0.3	48.75	Type 2	17.3355	0	-99 turnway, no recharge
14	287.5	349.7291	25	2	0.004	339.7291	62.937	0.3	48.75	Type 2	19.0485	0	-99 turnway, no recharge
15	262.5	348.4351	25	2	0.004	338.4351	62.937	0.3	48.75	Type 2	20.7615	0	-99 turnway, no recharge
16	237.5	347.1411	25	2	0.004	337.1411	62.937	0.3	48.75	Type 2	22.4745	0	-99 turnway, no recharge
17	212.5	345.8471	25	2	0.004	335.8471	62.937	0.3	48.75	Type 2	24.1875	0	-99 turnway, no recharge
18	187.5	344.5531	25	2	0.004	334.5531	62.937	0.3	48.75	Type 2	25.9005	0	-99 turnway, no recharge
19	162.5	343.2591	25	2	0.004	333.2591	62.937	0.3	48.75	Type 2	27.6135	0	-99 turnway, no recharge
20	137.5	341.9651	25	2	0.004	331.9651	62.937	0.3	48.75	Type 2	29.3265	0	-99 turnway, no recharge
21	112.5	340.6711	25	2	0.004	330.6711	62.937	0.3	48.75	Type 2	31.0395	0	-99 turnway, no recharge
22	87.5	339.3771	25	2	0.004	329.3771	62.937	0.3	48.75	Type 2	32.7525	0	-99 turnway, no recharge
23	62.5	338.0831	25	2	0.004	328.0831	62.937	0.3	48.75	Type 2	34.4655	0	-99 turnway, no recharge
24	37.5	336.7891	25	2	0.004	326.7891	62.937	0.3	48.75	Type 2	36.1785	0	-99 turnway, no recharge
25	12.5	335.4951	25	2	0.004	325.4951	62.937	0.3	48.75	Type 2	37.8915	0	-99 turnway, no recharge

AR 019996

**Table 5-7
Summary of Effective Basin Widths for Walker and Miller Creek Flow Estimates**

Basin & Slice Representation	Impermeable Area, IA (sf)	Permeable Area, PA= FS+OPA (sf)	Modeled Fill Area (MFA) = IA+PA (sf)	Slice		Active Slice Length (ASL, ft)	Effective Basin Width (EBW, ft)	Approx. Mapped Basin Width (MBW, ft)	Fraction of EBW
				Active Cell Count	Model Cell Length (ft)				
Walker Creek	277,072	452,475	729,547	14	25	350	2,084	2,300	100.0%
Slice 3									
Miller Creek	1,797,702	3,203,503	5,001,205	42	25	1,050	5,229	6,230	30.6%
Slice 1				37	30	1,110	2,699	3,700	51.6%
Slice 2				14	25	350	930	930	17.8%
Slice 3									

Note: lengths are measured east-west and widths are measured north-south.

FIGURES

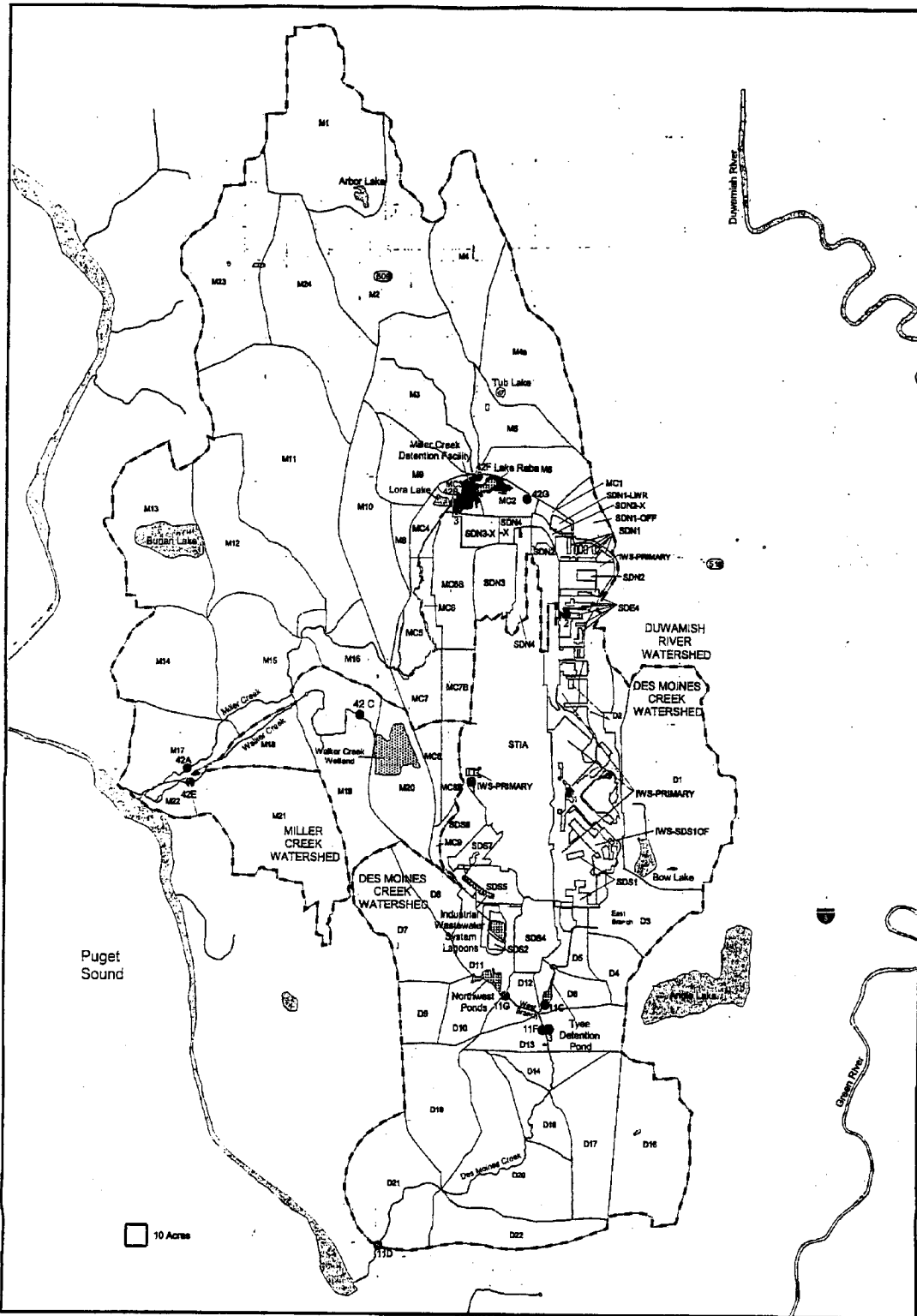

Parsons, Inc. See The Albany Department Management Plan 6/99-2/12/01/200 B90 File: K32438 (2)Arroyo/watershed-map_00001.dwg
 Source: Roads based on King County data. Water bodies derived from USGS hydrographic data. Divergent boundaries are approximate.
 Note: Subbasin boundaries shown outside of STIA area are for historical and reference only.
 STIA addresses sources existing (1994) conditions.

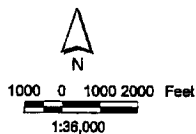

- Roads
- Existing (1994) Drainage Subbasins
- STIA Area (see note)
- Constructed Water Features
- IWS Drainage Area
- Subwatershed Boundary
- Watershed Boundary
- Rivers
- Water Bodies
- Detention Facilities (existing)

- Precipitation Gaging Station
- Type 1 - National Weather Service (Gage relocated 1980)
- Type 2 - PCB Rainfall Monitoring
- Type 3 - King County Rainfall Monitoring
- Streamflow
- King County Gaging Stations:
- 42A - Miller Cr. @ SW 178th Pl & 128th Ave SW
- 42B - Miller Cr. @ Lake Rabun/ROF Outlet
- 42C - Walker Cr. @ 171st Pl
- 42E - Walker Cr. @ 128th Ave SW
- 42F - Miller Cr. @ SR518
- 42G - Miller Cr. @ East Branch
- 110 - Des Moines Cr. near mouth
- 11F - Des Moines Cr. @ Golf Course
- 11G - Des Moines Cr. @ Tyee Pass
- 11G - Des Moines Cr. @ NW Ponds

**Figure 2-1
Map of Basins with
Gage Locations**

AR 019999

Figure 4-1 - Hydrus Model Output for Miller Creek Fill - Water Years 1991 - 1994

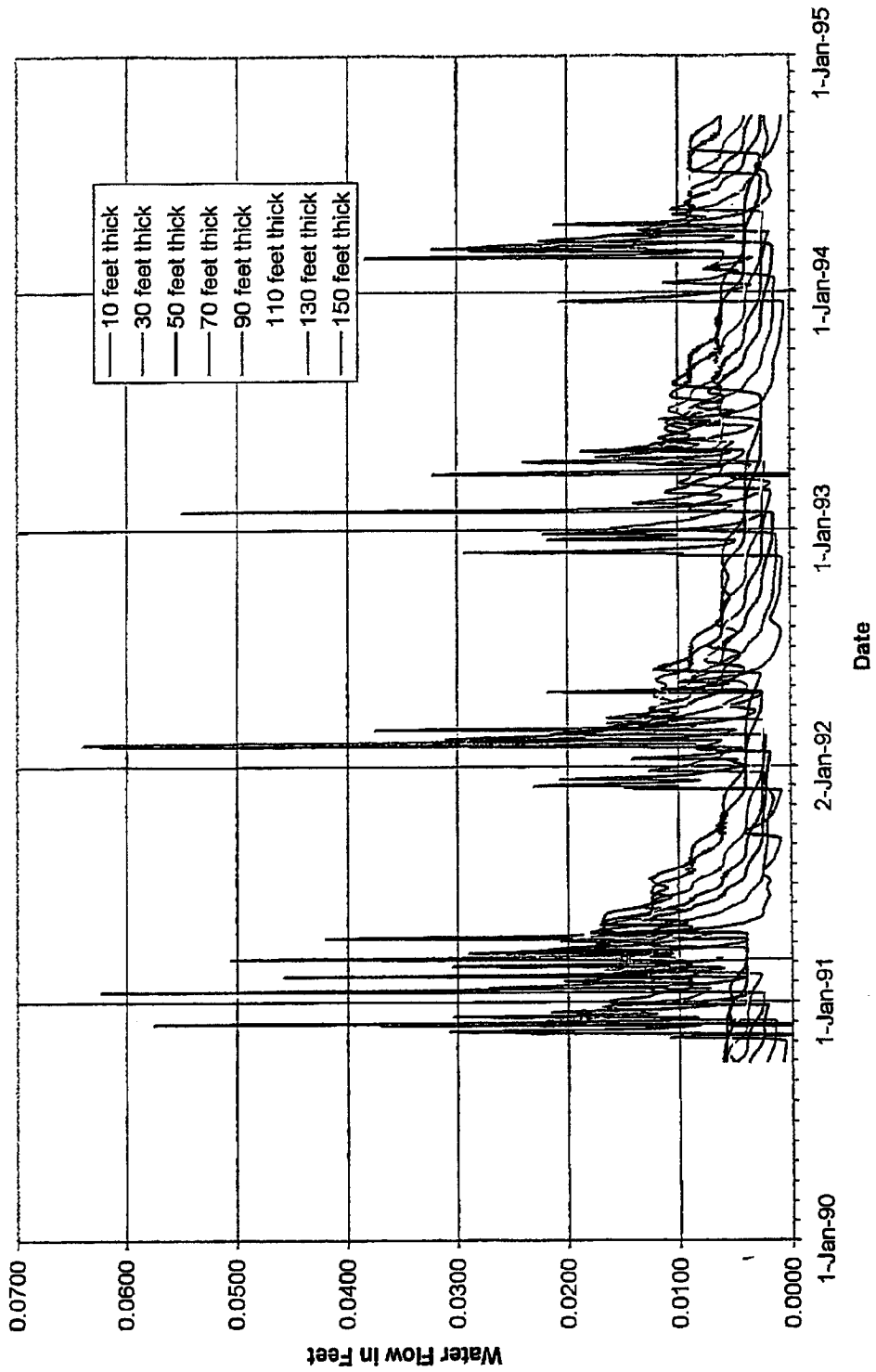
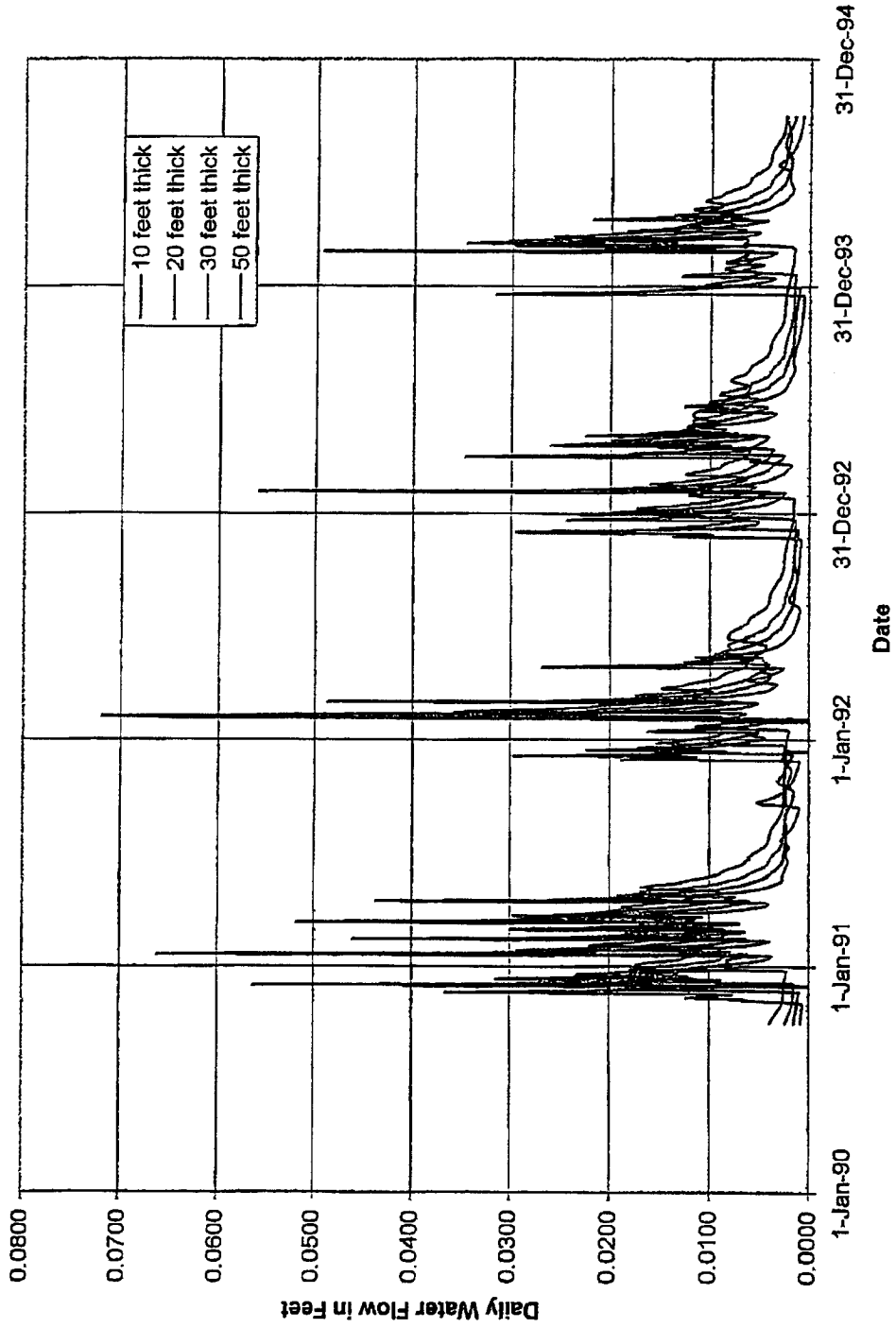

Figure 4-2 - Hydrus Model Output for Walker Creek Fill - Water Years 1991 - 1994



11/27/01

Walker Creek Output v2.xls, test period plot

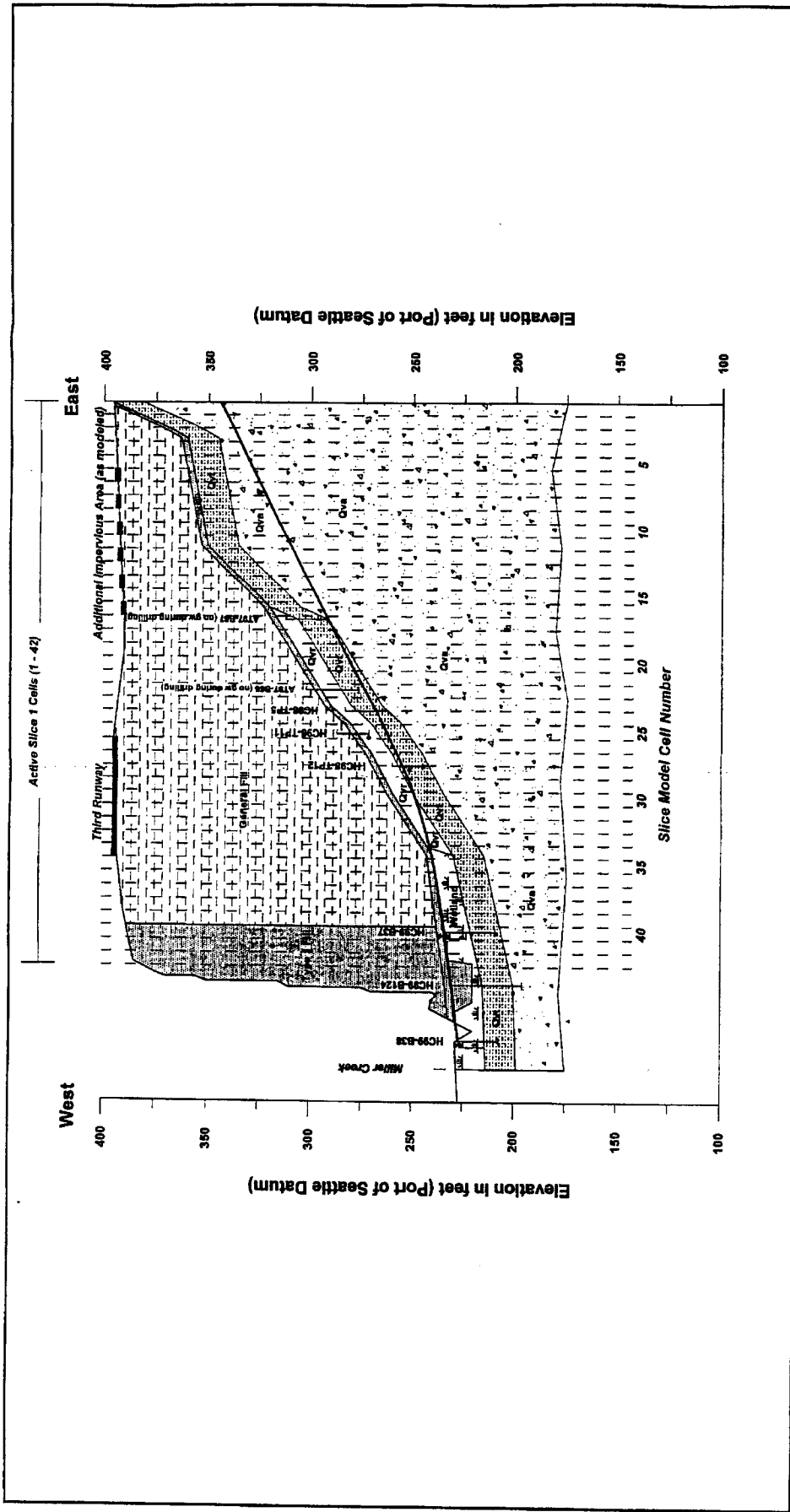

FIGURE 5-1
Simplified Cross Section for Slice 1

Seattle Third Runway
 Subaqueous Fill Modeling
 Project Number: 11/21
 Pacific Groundwater
 Group

LEGEND

- Groundwater Elevation
- Groundwater Seepage Elevation
- Conceptual Water Table
- General Fill
- Type 1 Fill
- Welland
- Grv - Vashon Recessional Outwash
- Grv - Vashon TBI
- Grv - Vashon Advance Outwash
- Well with high and low water level and identifier

Horizontal Scale in Feet: 0, 100, 200, 300, 400

Vertical Scale in Feet: 0, 25, 50, 75, 100

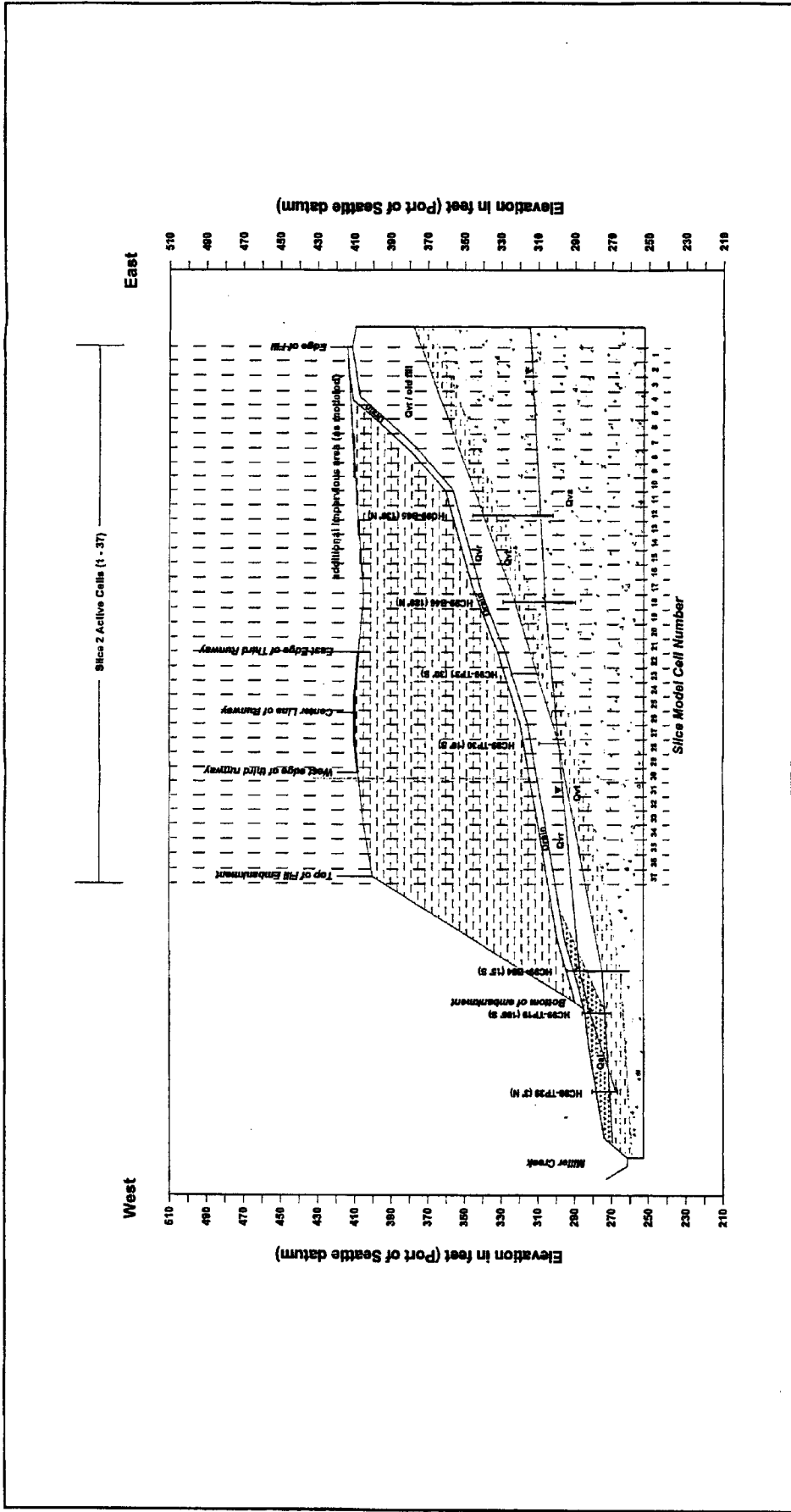

FIGURE 5-2
Simplified Cross Section for Slice 2

Seattle Third Runway
Embairment FEM Modeling
South, January 1998
RGS
Pacific
Group

LEGEND

x	Groundwater Elevation	Col. - Recrossed Manium
g	Groundwater Seepage Elevation	General Fill
y	Conceptual Water Table	Qvt - Vaishon Recessional Outwash
		Qvt - Vaishon Till
		Qve - Vaishon Advance Outwash

HCS-036

Horizontal Scale in Feet
0 100 200

Vertical Scale in Feet
0 25 50

Wall with high and low water level and Idanbler

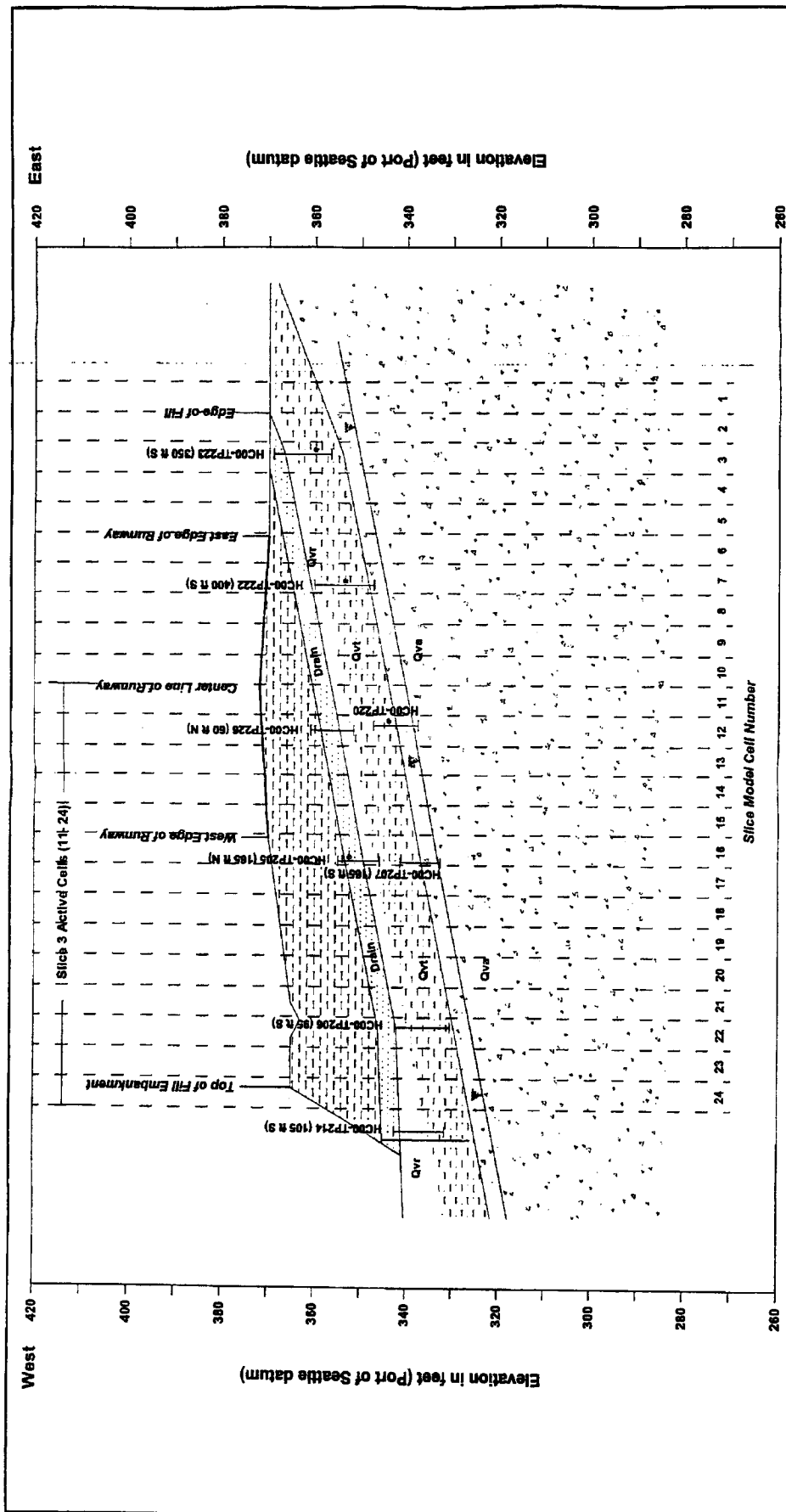

LEGEND

- X Groundwater Elevation
- ⊕ Groundwater Seepage Elevation
- Conceptual Water Table

General Fill

- Ovr - Vashon Recessional Outwash
- Ovt - Vashon Till
- Ora - Vashon Advance Outwash

Well with High and Low Water Level and Identifier

Horizontal Scale in Feet: 0, 10, 20, 40, 80

Vertical Scale in Feet: 0, 20, 40, 80

FIGURE 6-3
Simplified Cross Section for Slice 3

Surface Three Runway
Enlightenment for Maching
© 2004, Pacific Groundwater Group

Figure 5-4 Slice 1 Model Output for Test Period

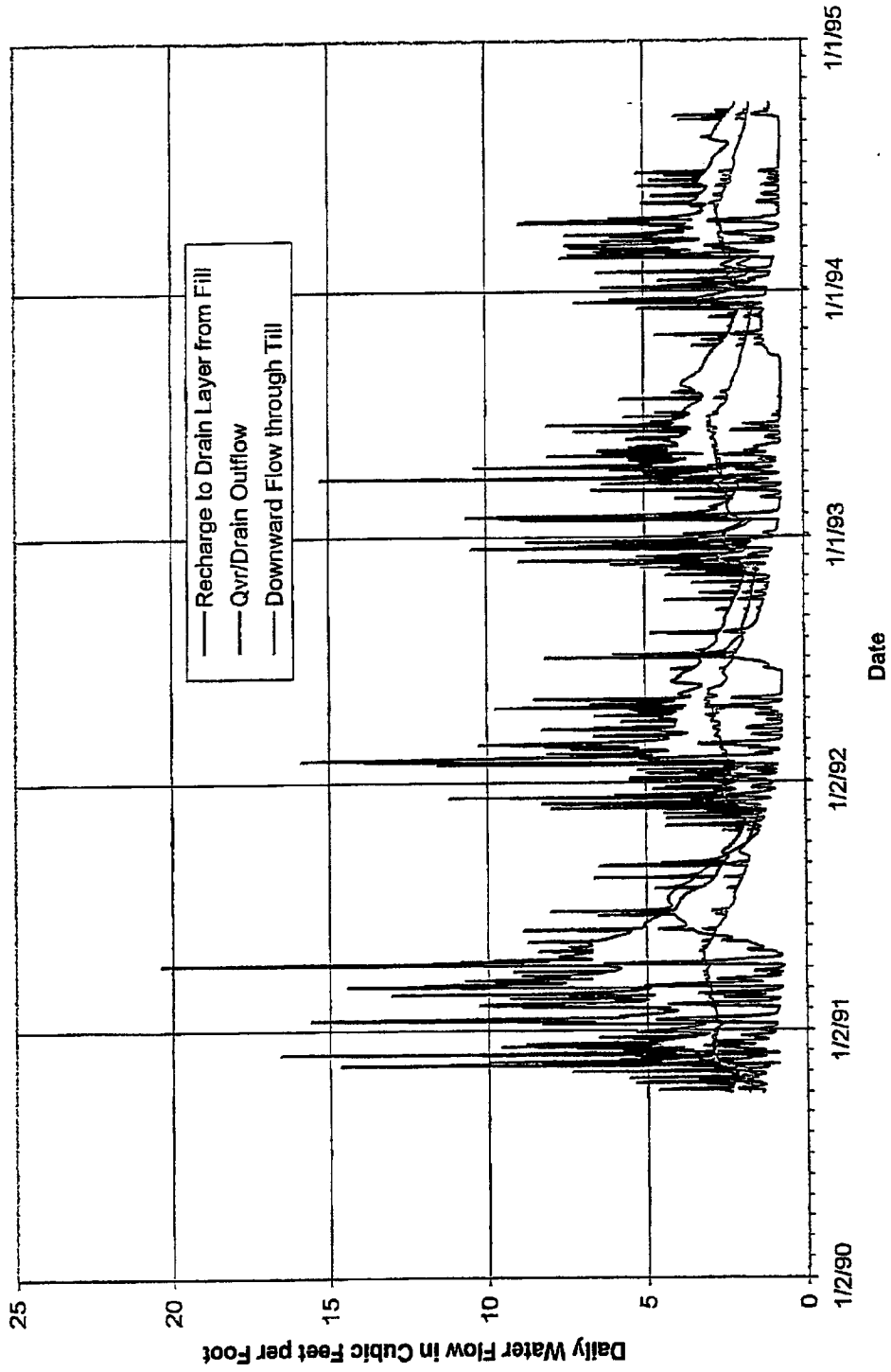

AR 020005

12/6/01

Slice-1-Daily-Results.xls,test period plot

Figure 5-5 - Slice 2 Model Output for Test Period

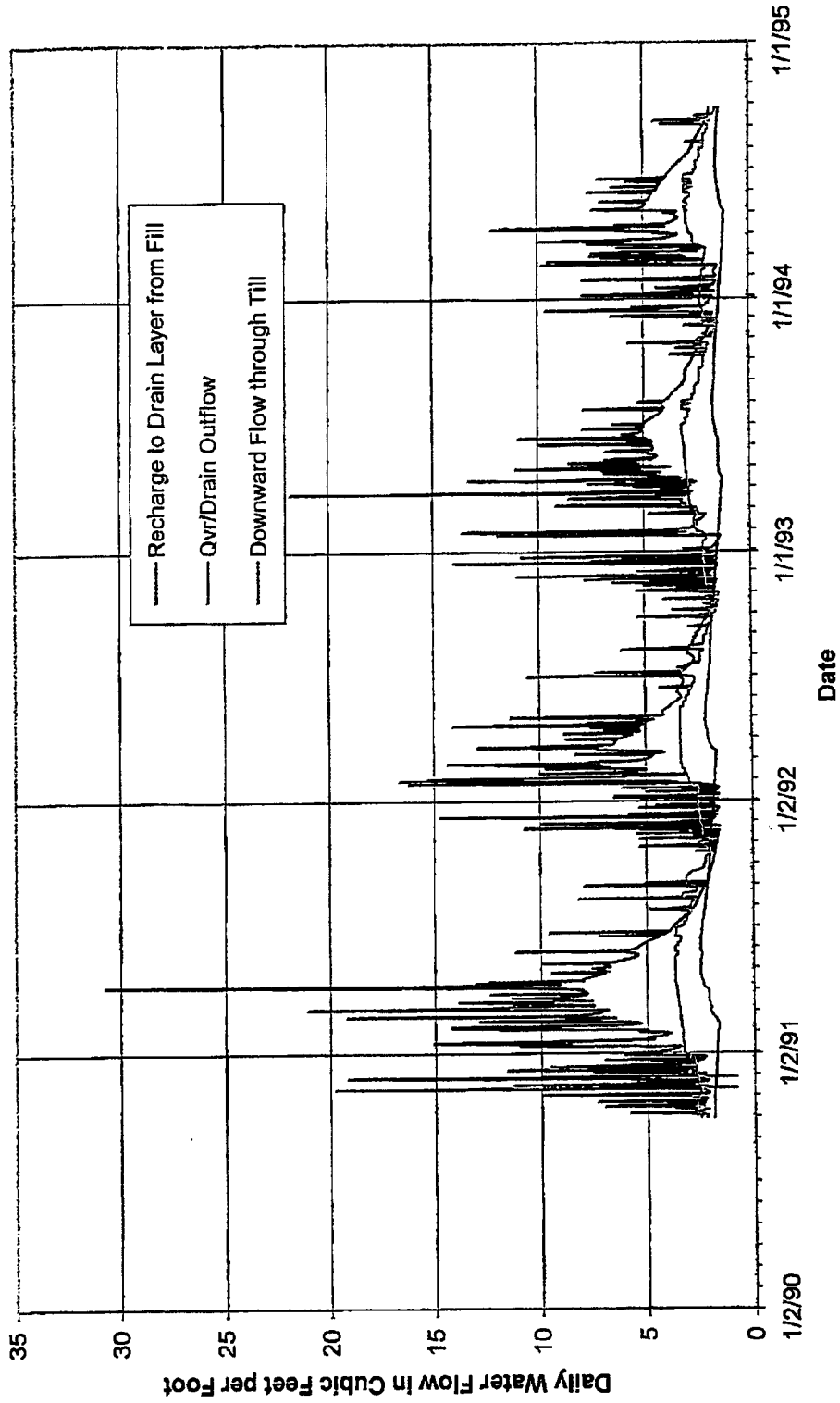

test period plot Chart 1, test period plot Chart 1

11/27/01

Figure 5-6 - Slice 3 Model Output for Test Period

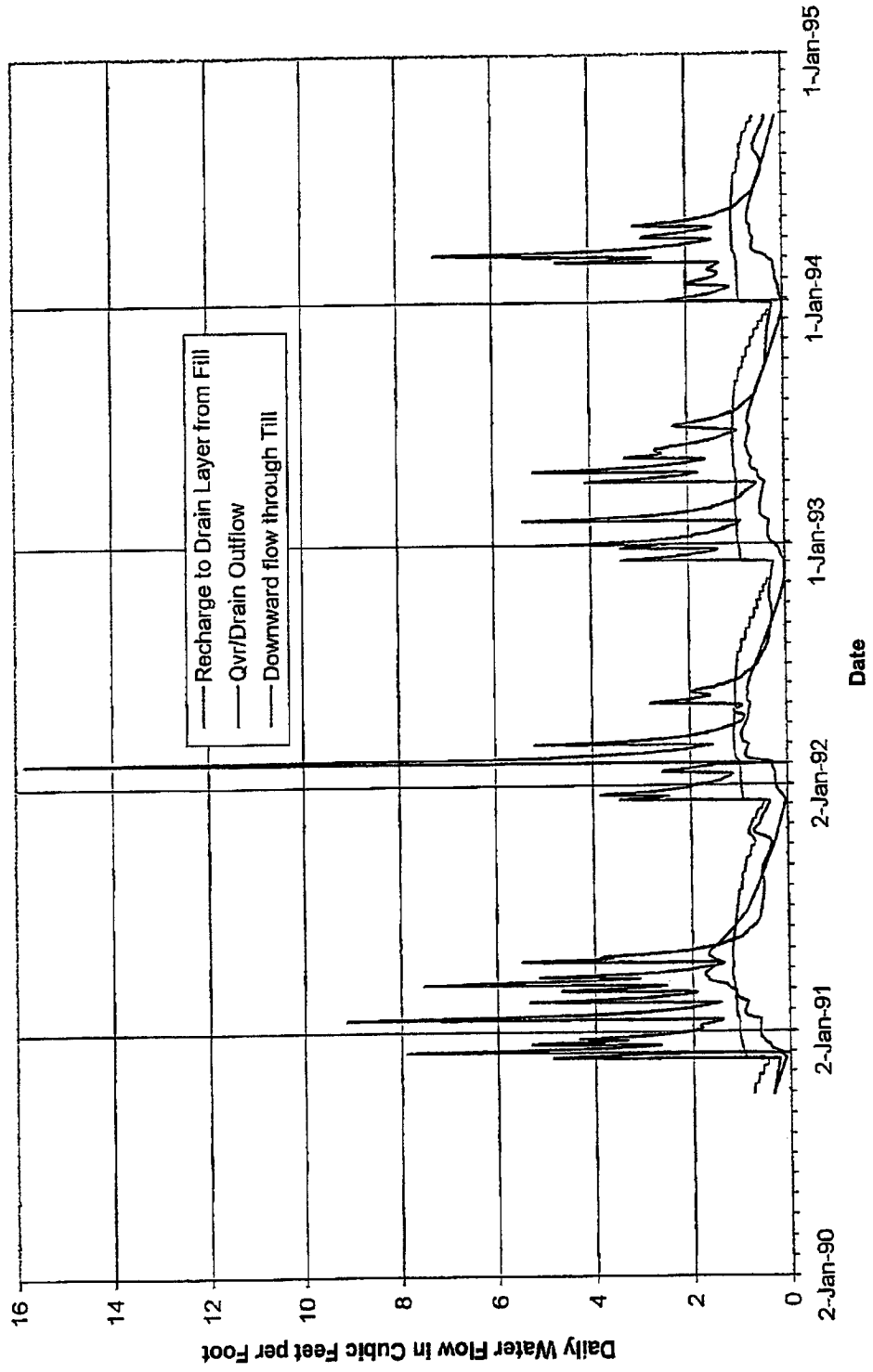

AR 020007

11/27/01

Figure 5-7 - Walker Creek Fill Inflow and Outflow for Test Period

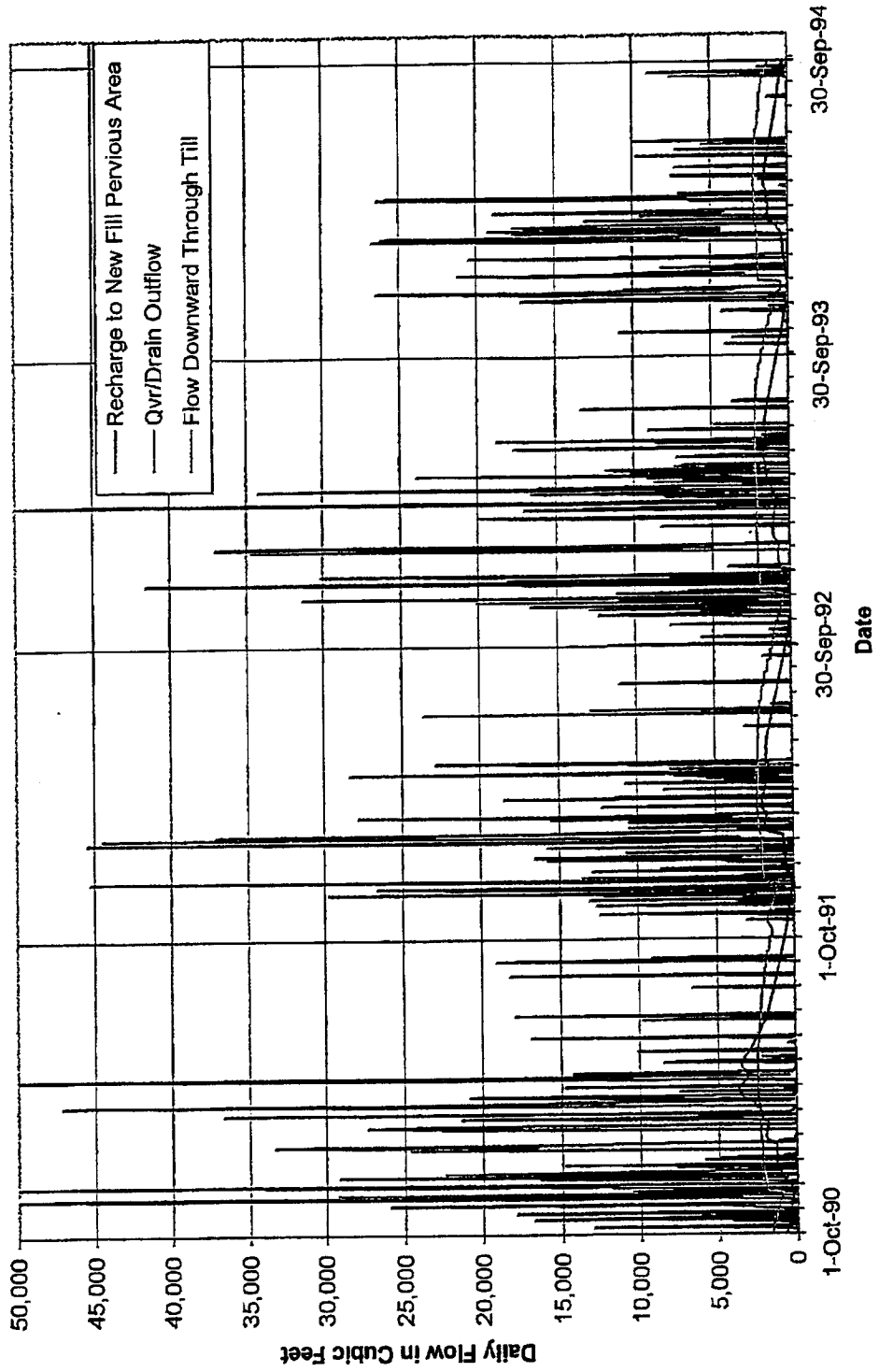
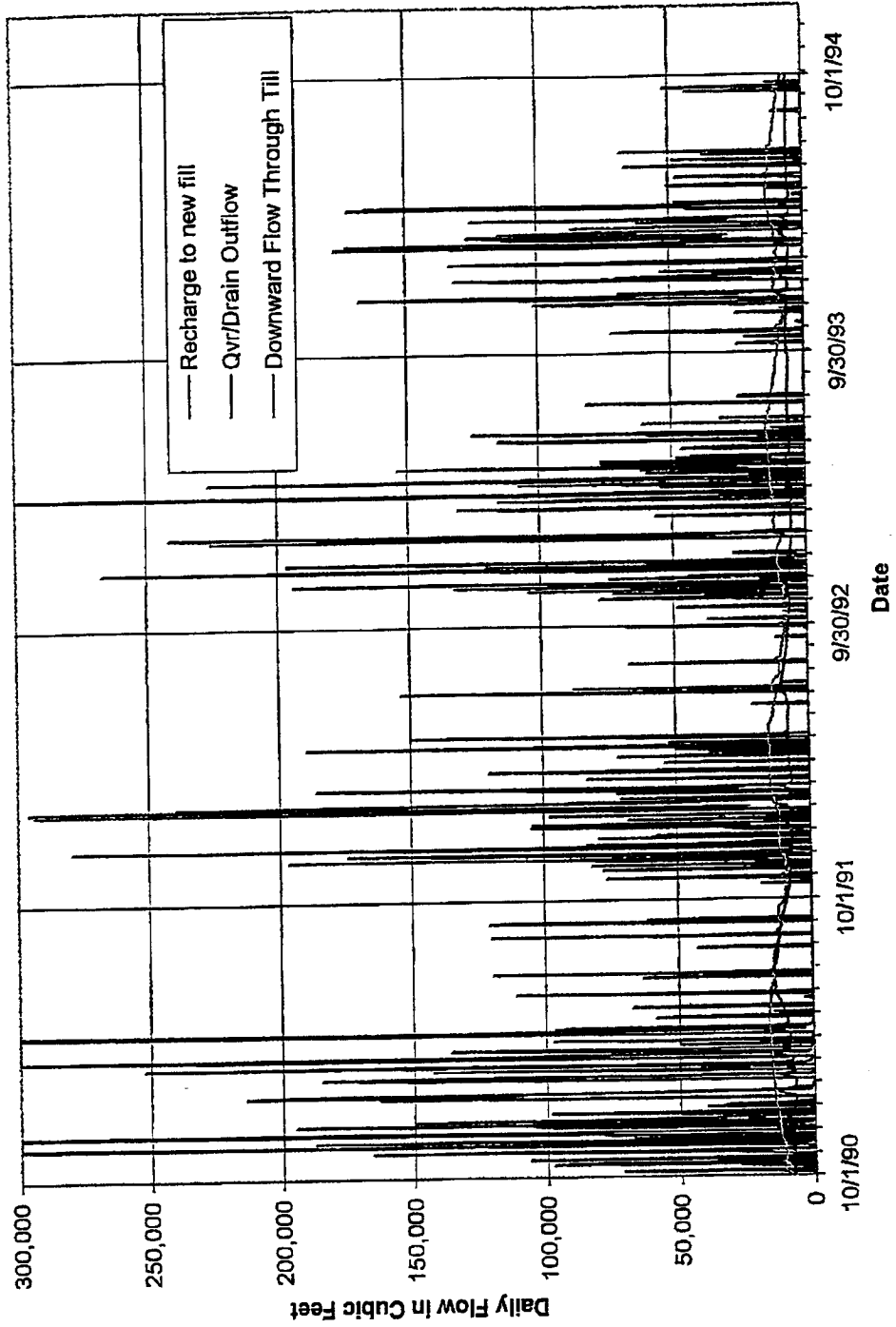

Figure 5-8 - Miller Creek Fill Inflow and Outflow for Test Period



APPENDIX C
EMBANKMENT INFILTRATION MEMORANDUM



The HNTB Companies

600 108th Ave., Suite 400, Bellevue, WA 98004

(425) 455-3555 • Fax (425) 453-9179 • Architectural Fax (425) 450-2597

Memorandum

To Michael Cheyne, PMP
Third Runway Program Leader

From Jim Thomson, P.E., HNTB
Mike Bailey, P.E., Hart Crowser
Michael Kenrick, P.E., Hart Crowser

Subject Third Runway Embankment Infiltration

Date October 26, 2000

Summary

Sometime ago, the Third Runway Design Team was asked to consider taking steps toward providing enhanced infiltration within the embankment. Because of the stormwater detention benefit infiltration provides, the team had already reviewed the possibilities of enhanced infiltration and believed the project could provide opportunity in the following ways:

- Use of flatter cross slopes on the airfield providing greater stormwater residence time on pervious surfaces.
- Longer water courses over pervious surfaces prior to storm sewer collection also increasing residence time.
- Use of a variety of naturally occurring fill materials allowing for some infiltration while continuing to provide stability.

Recently, the design team was asked to provide additional infiltration beyond what would occur from the design approach outlined above. We have evaluated alternatives, which would meet both design goals of enhanced infiltration and embankment stability. The design team believes that artificially increasing the amount of infiltration beyond standard design and construction practice for an embankment of this depth would increase the risk of instability, increase construction complexity and costs, and may result in adverse impacts beyond the embankment limits. We believe the benefit, which might be provided through enhanced infiltration, is out-weighted by the increased risks to the embankment.

Embankments that are designed and constructed for storm water retention, reservoirs, etc. are typically built as zoned embankments, with different soil material zones used to control seepage and provide necessary drainage or strength to accommodate the resultant pore pressures. The proposed Third Runway embankment is a type of zoned embankment, but its zones were designed to optimize support of the airfield pavement sections with minimum long term risk. The increased risks resulting from enhanced infiltration are:

- Increased risk of surficial slope stability problems related to seepage
- Increase risk of subgrade liquefaction base stability
- Increased construction complexity
- Long term maintenance issues

A more detailed discussion of the increased risks follows in the next section of this memorandum.

Details of Increased Risk

1. Increased Risk of Surficial Slope Stability Problems Related to Seepage

Side slopes for the proposed embankment are designed to be constructed of readily available soil fill, which can achieve the strength needed with conventional construction methods. The strength necessary for the fill depends on a number of factors, but mainly on the angle of the side slopes, drainage conditions, anticipated seismic loads and foundation conditions. Increasing the amount of water infiltrated into the embankment has the potential to reduce stability by increasing pore pressures. This would have three adverse effects:

- Increased risk of piping and erosion-related instability ("sloughing") of the embankment side slopes due to seepage forces and loss of support where the seep exits the embankment surface;
- Increased soil bulk density due to the added weight of water, which will contribute to the potential for failure of the embankment; and
- Decreased soil strength near the surface of the slope but within the embankment (the effective strength available from soil friction is less than the unsaturated total strength by an amount equal to the increase in pore pressure).

Making a commitment to a specific flow rate and flow timing (during late summer), would require a specific water volume retained. Soil engineering would need to be based on flow rate and not stability.

2. Increased Risk of Subgrade Liquefaction Base Stability

Native soils that provide the foundation for the Third Runway embankment generally consist of a layer of relatively loose to moderately dense sands and interbedded cohesive soils, overlying very dense or hard, glacially overridden soils. Typically there is a layer of groundwater perched on top of the more dense glacial soils, and in some areas this saturated soil zone is subject to significant strength loss during seismic shaking – a process referred to as "liquefaction". The design team has defined some areas where subgrade improvements (i.e., densification or replacement of the native soil) are needed to mitigate liquefaction.

Artificially increasing the amount of infiltration into the embankment would likely lead to an increase in groundwater levels below the embankment, and thus increase the risk and area of potential liquefaction. The extent of this change is difficult to predict and thus an increase in risk would result. (A portion of the additional infiltration is expected to discharge via the underdrain. However, the underdrain is designed to prevent build-up of pore pressures in the fill placed above the drain and will not prevent the water table beneath the embankment from rising to the level of the drain itself; i.e., to the existing ground level).

Potential adverse impacts of liquefaction include reduced embankment stability due to loss of soil shear strength, as well as potential vertical displacement or other ground disturbance (e.g., "sand boils") along the relatively level ground adjacent to the embankment. The potential for liquefaction of native soils adjacent to the embankment already exists, but the risk of occurrence and magnitude would be increased by raising existing groundwater levels, as a direct result of increased infiltration.

3. Increased Construction Complexity and Cost

Specifications for embankment construction to date have included a range of soil fill materials in order to obtain cost competitive bids while supporting airfield pavement sections. Modification of the embankment to increase infiltration would increase complexity of construction and is anticipated to increase construction costs in one or all of the following ways:

- Soil fill used to enhance infiltration would need to be a select material, since the infiltration capacity of sand and gravel decreases rapidly as the percentage of clay and silt increases even moderately. Using bids from the current year for comparison, the cost of the Group 1, non-silty (or "freely draining") soil to enhance infiltration, compared with the more silty Groups 2, 3 and 4 soil used as common embankment fill is about 200 percent more expensive.
- Note that the cost difference presented above does not present the complete picture. Restricting the gradation of the fill material would restrict the number of sources that could supply it, and that along with an increase in the total amount of non-silty soil that needs to be used could possibly increase the unit cost. Further cost increases related to construction management and survey control would also probably occur in the event that placement is required to configure special infiltration zones within the embankment.
- Increased pore pressures within the embankment and liquefaction susceptible subgrade soils would need to be mitigated to achieve the same factor of safety as obtained for the embankment without enhanced infiltration. This mitigation could include use of higher strength embankment material and/or by increased subgrade improvements. Increased costs would result from using higher quality or more highly compacted fill soils; reinforcing the fill; and increasing the area of coverage and/or increasing the density of subgrade improvements within existing areas.

4. Increased Need for Long-term Maintenance and Associated Risks

There are a number of alternatives available that initially appear to provide some opportunity to increase infiltration into the embankment, such as increasing length between catch basins in grassed areas between pavement; infiltration swales; perforated pipes extending from catch basins; a surficial layer of plating sand, etc. All of these approaches are likely to require some degree of maintenance in order to prevent siltation, bacteriological clogging, and/or other problems to provide effective long-term functioning.

Drains in general need to have some means of being cleaned out, and this applies equally to soil zones used to promote infiltration and transmit seepage. There is virtually no way to maintain an infiltration system deep within an embankment. It is also worth noting that once the embankment has been constructed, there will be no way to detect or "unclog" a failed infiltration system deep within the interior of the embankment. Furthermore, a failed system will increase the potential for a stability failure within the embankment.

Appendix D

AR 020015

APPENDIX D
NON-HYDROLOGIC IMPACTS SUPPORT DATA

CERTIFICATE OF ENGINEER

The technical material and data contained in this appendix were prepared under the supervision and direction of the undersigned, whose seal, as a professional engineer licensed to practice as such, is affixed below.



A handwritten signature in black ink, appearing to read "Richard L. Schaefer", written over a horizontal line.

Richard L. Schaefer, P.E.

(affix seal here)

Historic Water Withdrawals from Miller Creek

Documentation

This spreadsheet was created for the purpose of developing a time series representing water withdrawal from Miller Creek due to pumping. This time series is intended to represent conditions prior to the removal of homes in the buyout area.

The worksheet "Annual Time Series" contains the estimated annual water withdrawal from Miller Creek. The total water withdrawal is shaded in yellow in Column B. It is the sum at each hour of the estimated water withdrawal from each parcel contained in Columns C - Y

The time series was constructed using the values and notes presented in Table 2-7. Key notes from Table 2-7 used to construct the time series are listed below:

The quantity of water withdrawn was estimated as follows:

Available Pumping Rate x Estimated Months of Water Use Per Year x 0.5 (daily pumping duration)

The time series was constructed using the available pumping rate for 12 hours per day (6 am to 6 pm each day).

Estimated months of water use per year was assumed as follows:

6 Months = April 1 - Sep 30

4 Months = June 1 - Sep 30

Summary of Historic Miller Creek Withdrawal Time Series

Date From	Date To	Time From	Time To	Withdrawal (cfs)
1-Jan	31-Mar	12:00 AM	12:00 AM	0.000
1-Apr	31-May	6:00 AM	6:00 PM	0.033
		6:00 PM	6:00 AM	0.000
1-Jun	30-Sep	6:00 AM	6:00 PM	0.042
		6:00 PM	6:00 AM	0.000
1-Oct	16-Oct	6:00 AM	6:00 PM	0.001
		6:00 PM	6:00 AM	0.000
17-Oct	31-Dec	12:00 AM	12:00 AM	0.000

Historic Groundwater Recharge of Imported Water through Septic Systems

Documentation

This spreadsheet was created for the purpose of developing time series representing water recharge from water imported into the buyout area via water distribution systems. Recharge takes two potential forms: 1. recharge from septic systems; 2. recharge from infiltration of irrigation water. These time series is intended to represent conditions prior to the acquisition and removal of homes in the buyout area.

The time series on this worksheet (Recharge from Septic) represents water recharge from septic systems in the buyout area. The recharge to each watershed from septic systems was based on estimated water consumption. Recharge from septic systems is based on winter water use. Additional water use during summer months (above and beyond winter water use) is provided in a separate time series.

The estimated annual water recharge from septic systems in the buyout area to each of the three watersheds is provided below in Columns A - D. The model time series was constructed with an hourly time step. However, the recharge rates shown below reflect estimated daily recharge.

Estimated Recharge Quantity

	Miller Creek	Walker Creek	Des Moines Creek	
Number of Active Septic Tanks	236	41	0	Total of 291 homes were served by septic in Walker and Miller Creek Basins prior to the buy-out. Some of these homes (14) were also served by sewer, and the septic systems were inactive. Based on inventory of septic tanks removed, there were 41 active tanks in the Walker Creek basin buy-out area and 236 in the Miller Creek basin buy-out area (total 277 active tanks, 14 inactive).
Winter Water Use (gallons per home per day)	249	249	249	Winter water use was used to estimate recharge from septic systems. Typical values for winter water use were provided by Water District #20 and Water District #125.
Recharge from Septic Systems (gallons per day)	52,962	9,201	-	Estimated recharge to groundwater within each watershed expressed in gallons per day (number of active tanks multiplied by 90 percent of winter water use rate).
Contribution to streamflow (cfs)	0.0574	0.0100	-	Estimated portion of groundwater recharge available to support streamflows (70 percent of recharge to groundwater).

APPENDIX E
HEC-RAS MODELING INFORMATION AND FIELD SURVEY DATA

	Average Change in Flow Depth (ft)	Average Change in Flow Depth (mm)	Average Change in Top Width (ft)	Average Change in Top Width (mm)
Miller Creek	0.00 ft	0 mm	0.02 ft	6 mm
Walker Creek	-0.01 ft	-3 mm	-0.10 ft	-30 mm
Des Moines Creek	-0.03 ft	-9 mm	-0.33 ft	-101 mm

Miller Creek

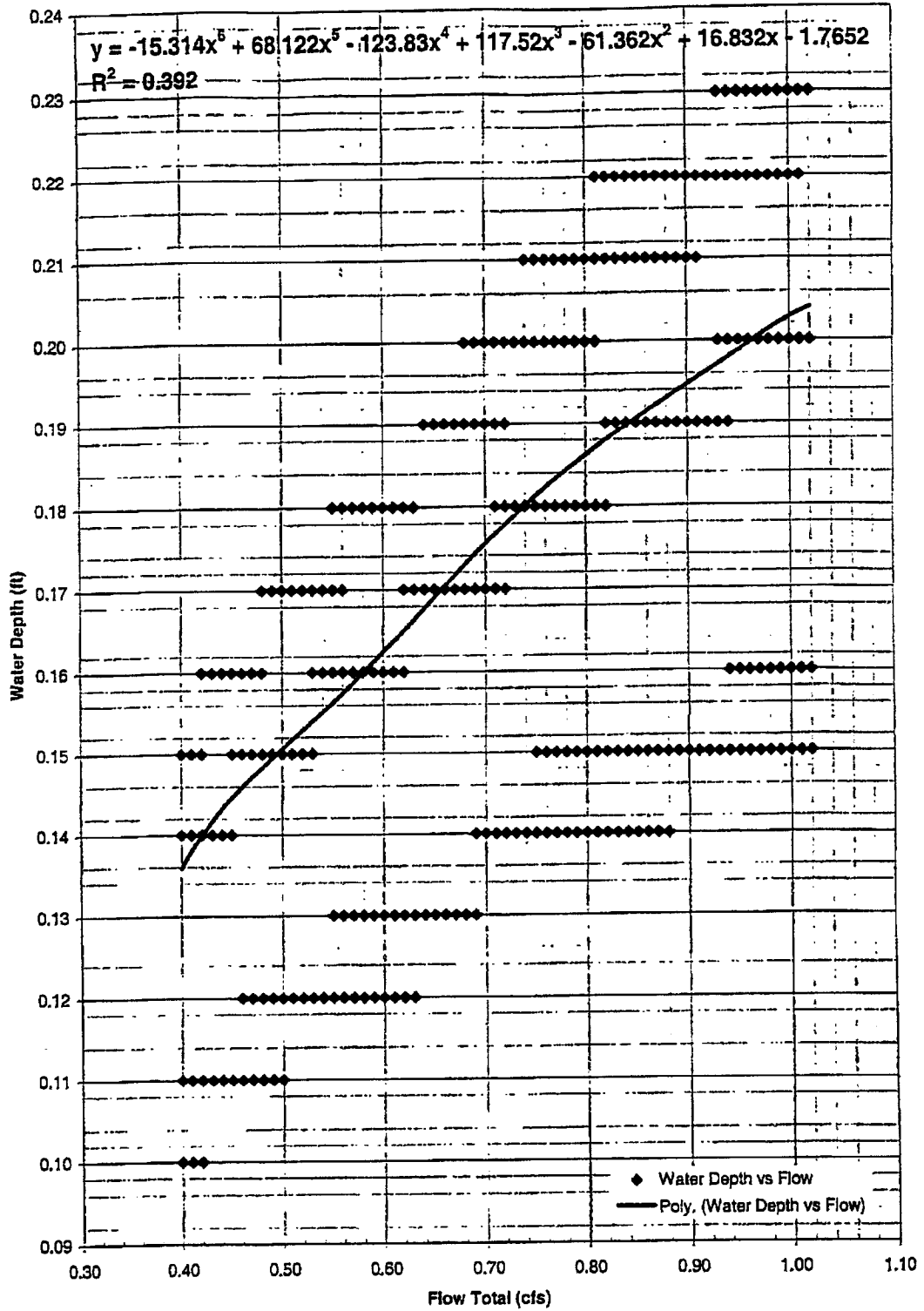

K:\working\2912\2912(28B)\HecRas Values.xls Miller Creek Q vs H2O Depth

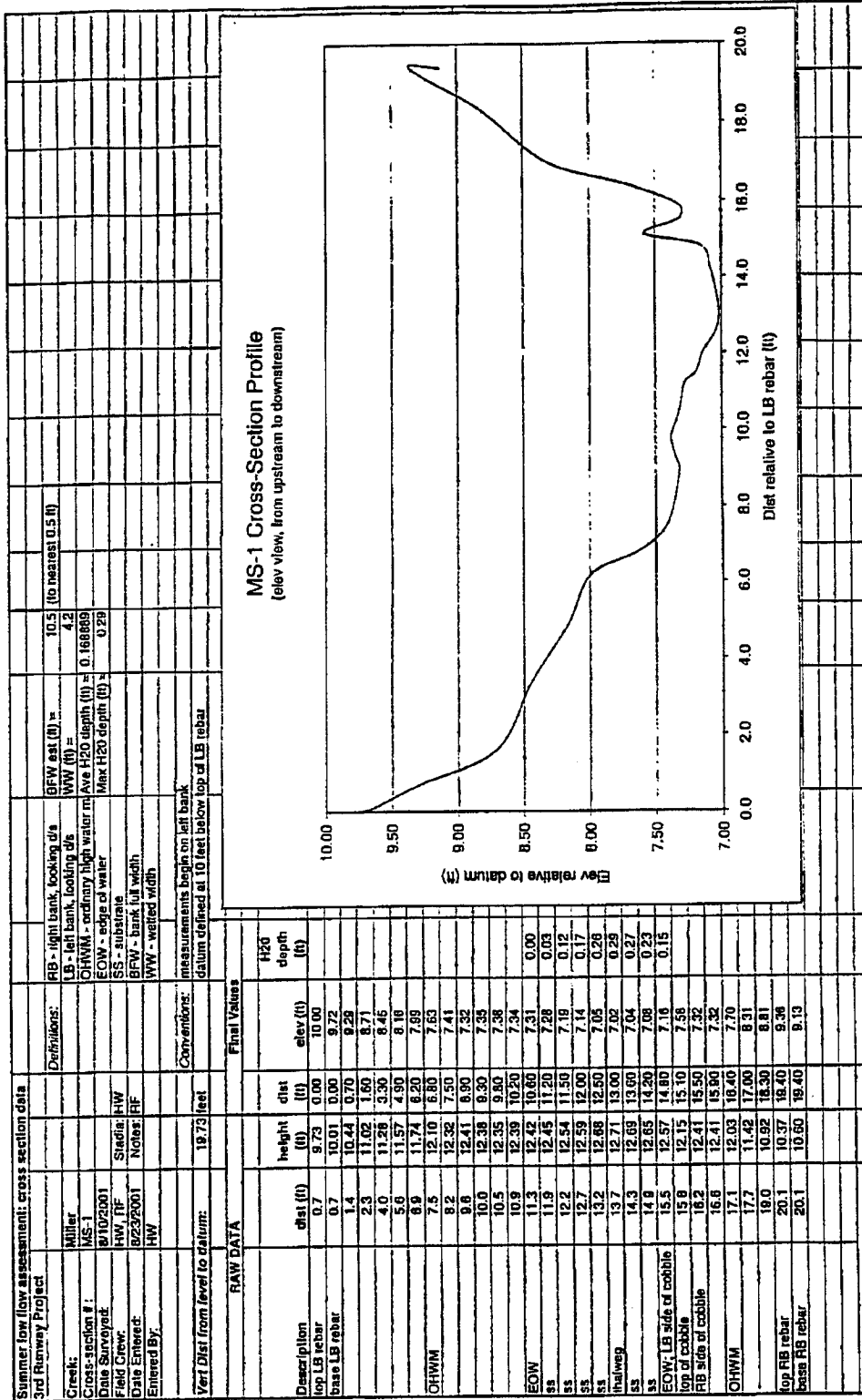

Paramet... Inc.
Port of Seattle
554-2912-28B

Miller Creek Low Flow Analysis

Checked By: 
By: Angé... Wilcox
December 6, 2001

Miller Creek Cross Section M-1 Change in Low Flow Water Surface Elevations

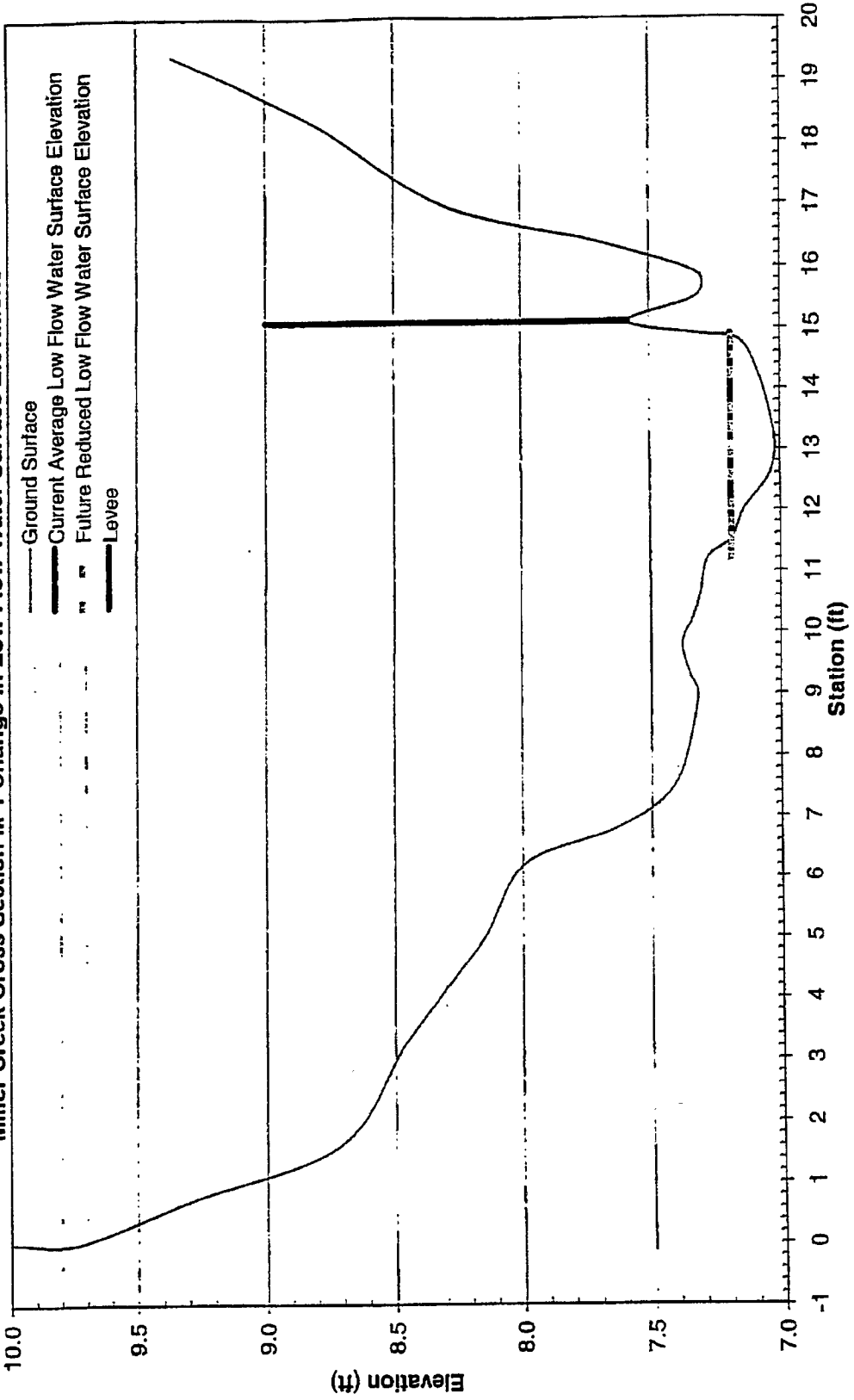

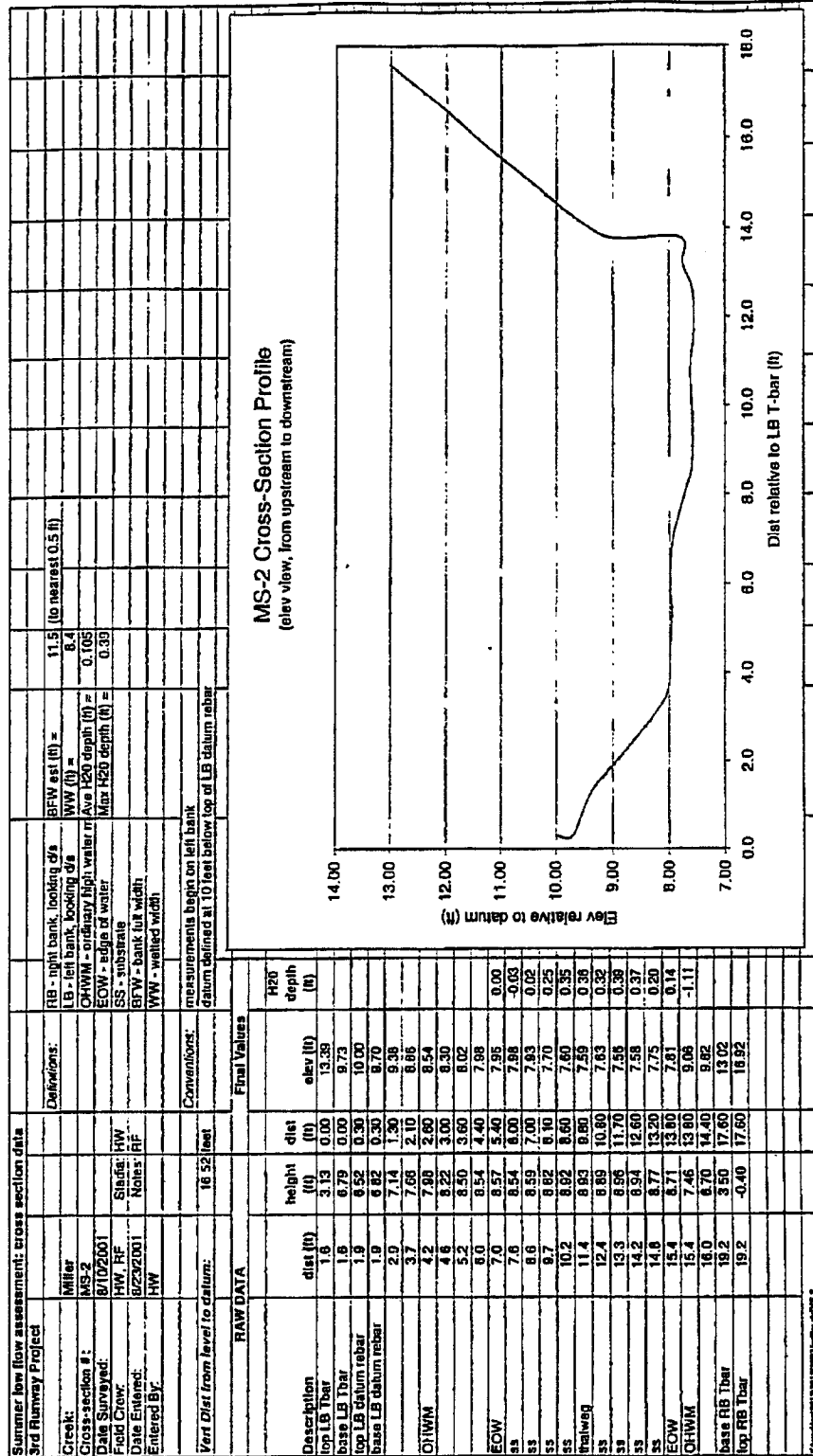

Param... Inc.
Port of Seattle
554-2012-28B

Miller Creek Low Flow Analysis

By: Ange. Wilcox

Checked By:

December 6, 2001

Miller Creek Cross Section M-2 Change in Low Flow Water Surface Elevations

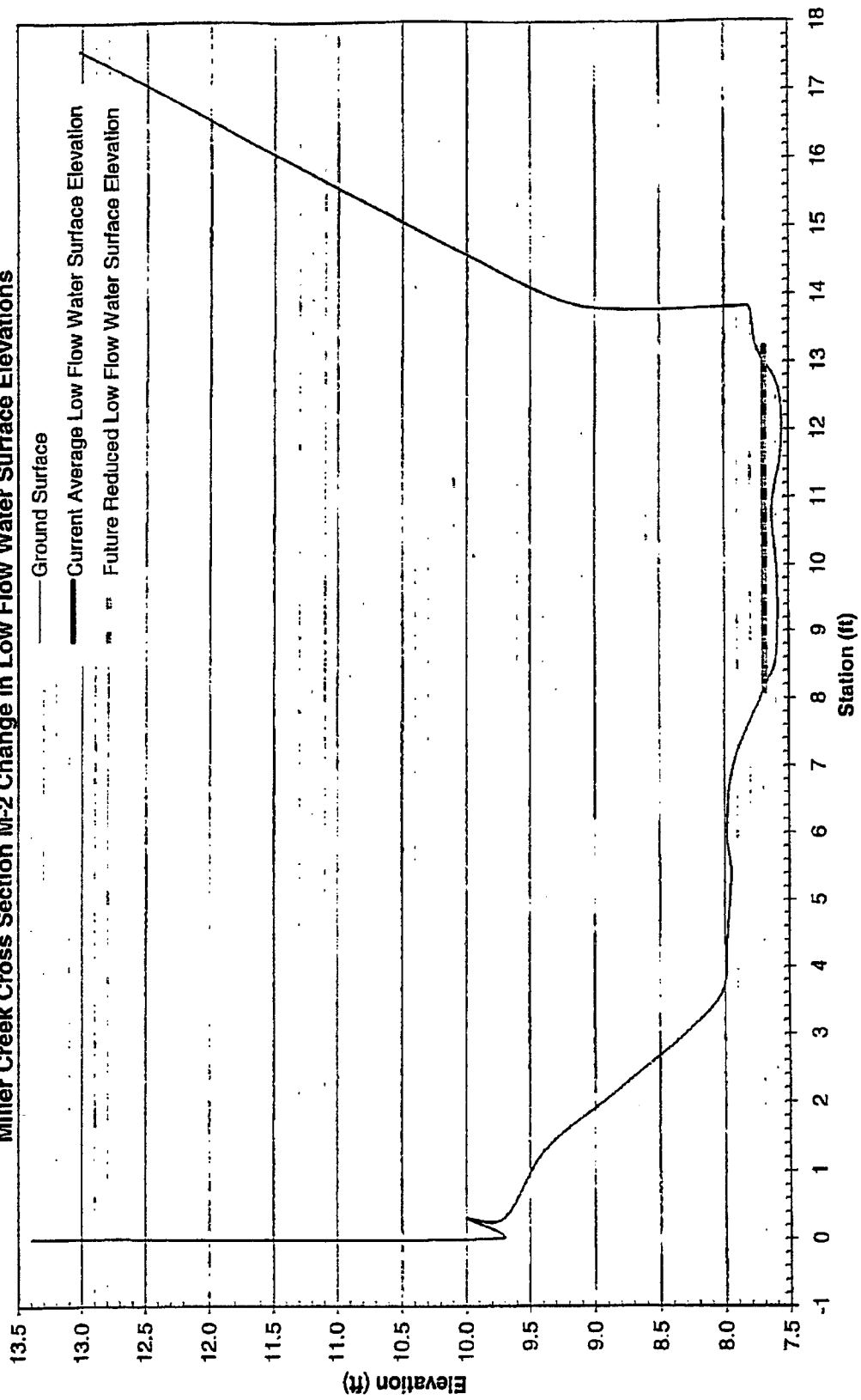

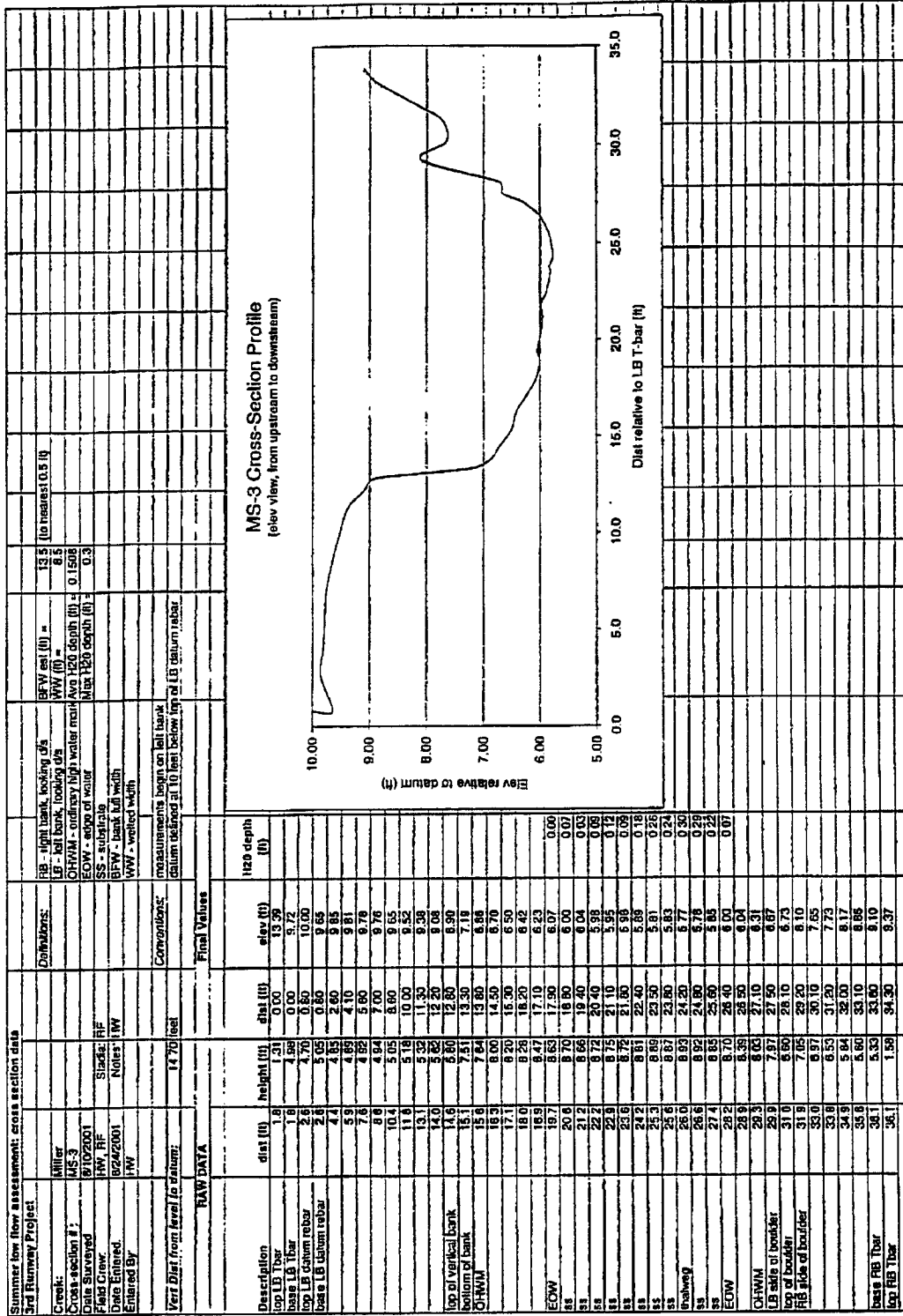

Parametrix Inc.
Port of Seattle
554-2912-28B

Miller Creek Low Flow Analysis

Checked By:  By: Angela Wilcox
December 6, 2001

Miller Creek Cross Section M-3 Change in Low Flow Water Surface Elevations

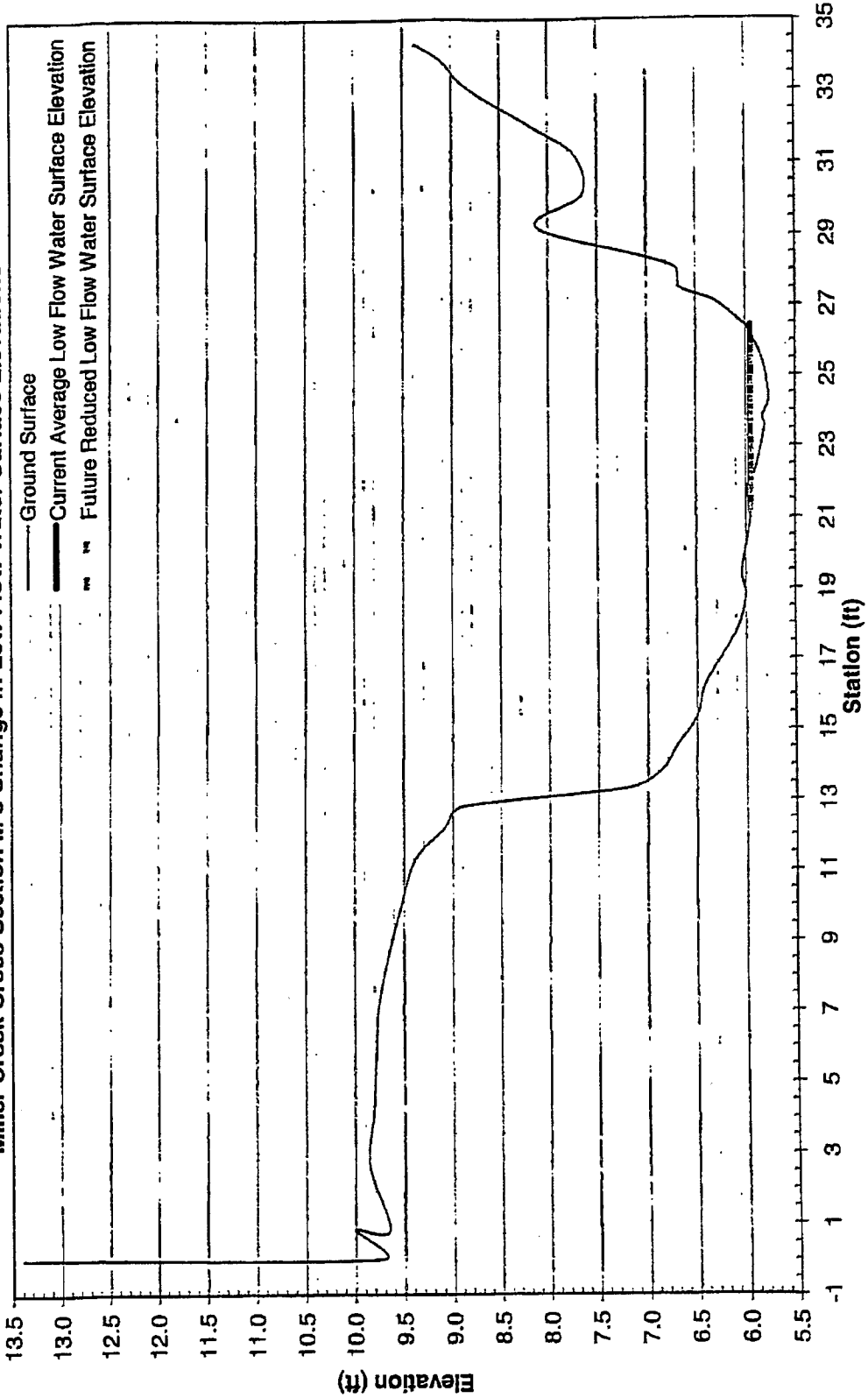

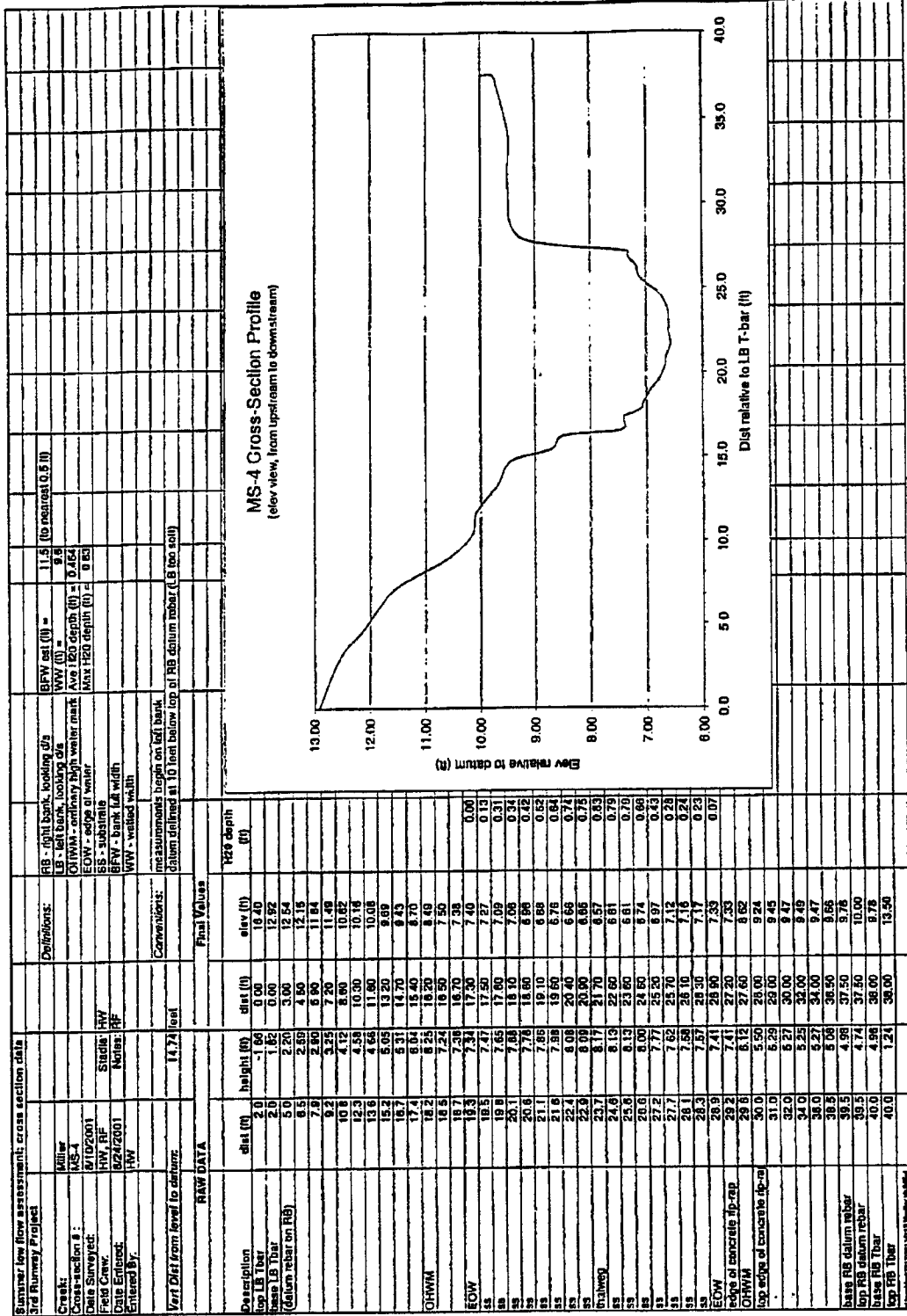

Summary low flow assessment; cross section data
3rd Runway Project

Creek: Millier
Cross-section #: MS-4
Date Surveyed: 8/10/2001
Field Crew: RW, RF
Date Entered: 8/24/2001
Entered By: RW

Stadia: RF
Notes: RF

Vert Dist from level to datum: 14.71 feet

RAW DATA

Description	dist (ft)	height (ft)	dist (ft)	elev (ft)	R2R depth (ft)
Top LB T-bar	2.0	-1.60	0.00	18.40	0.00
Base LB T-bar	2.0	1.62	6.00	12.92	0.31
(datum rebar on RB)	5.0	2.20	3.00	12.54	0.12
	6.5	2.89	4.50	12.15	0.52
	7.9	2.80	6.90	11.84	0.84
	9.2	3.25	7.20	11.49	0.75
	10.8	4.12	8.60	10.82	0.70
	12.3	4.58	10.30	10.16	0.68
	13.6	4.68	11.80	10.06	0.67
	15.2	5.05	13.20	9.89	0.64
	16.7	5.31	14.70	9.43	0.65
	17.4	6.04	15.40	8.70	0.66
	18.2	6.25	16.20	8.49	0.65
	18.5	7.24	16.50	7.50	0.68
	18.7	7.38	16.70	7.38	0.68
	18.3	7.34	17.30	7.40	0.68
	18.5	7.47	17.50	7.27	0.68
	19.9	7.65	17.80	7.09	0.68
	20.1	7.84	18.10	7.06	0.68
	20.6	7.76	18.60	6.88	0.68
	21.1	7.85	19.10	6.88	0.68
	21.6	7.88	19.60	6.76	0.68
	22.4	8.08	20.40	6.66	0.68
	22.9	8.09	20.90	6.86	0.68
	23.7	8.17	21.70	6.57	0.68
	24.6	8.13	22.60	6.81	0.68
	25.6	8.13	23.60	6.61	0.68
	26.6	8.00	24.60	6.74	0.68
	27.2	7.77	25.30	6.97	0.68
	27.7	7.62	25.70	7.12	0.68
	28.1	7.88	26.10	7.16	0.68
	28.3	7.59	26.30	7.17	0.68
	28.9	7.41	26.90	7.33	0.68
	29.2	7.11	27.20	7.53	0.68
	29.8	6.12	27.60	6.92	0.68
	30.0	5.50	28.00	6.28	0.68
	31.0	5.29	29.00	6.45	0.68
	32.0	6.27	30.00	6.47	0.68
	34.0	5.25	32.00	6.49	0.68
	36.0	5.27	34.00	6.47	0.68
	38.5	5.08	36.90	6.86	0.68
	39.5	4.98	37.50	6.76	0.68
	39.5	4.74	37.50	10.00	0.68
	40.0	4.96	38.00	6.76	0.68
	40.0	1.24	38.00	13.50	0.68

Final Values

Dist (ft)	Elev (ft)	R2R depth (ft)
0.00	18.40	0.00
6.00	12.92	0.31
3.00	12.54	0.12
4.50	12.15	0.52
6.90	11.84	0.84
7.20	11.49	0.75
8.60	10.82	0.70
10.30	10.16	0.68
11.80	10.06	0.67
13.20	9.89	0.64
14.70	9.43	0.65
15.40	8.70	0.66
16.20	8.49	0.66
16.50	7.50	0.68
16.70	7.38	0.68
17.30	7.40	0.68
17.50	7.27	0.68
17.80	7.09	0.68
18.10	7.06	0.68
18.60	6.88	0.68
19.10	6.88	0.68
19.60	6.76	0.68
20.40	6.66	0.68
20.90	6.86	0.68
21.70	6.57	0.68
22.60	6.81	0.68
23.60	6.61	0.68
24.60	6.74	0.68
25.30	6.97	0.68
25.70	7.12	0.68
26.10	7.16	0.68
26.30	7.17	0.68
26.90	7.33	0.68
27.20	7.53	0.68
27.60	6.92	0.68
28.00	6.28	0.68
29.00	6.45	0.68
30.00	6.47	0.68
32.00	6.49	0.68
34.00	6.47	0.68
36.90	6.86	0.68
37.50	6.76	0.68
37.50	10.00	0.68
38.00	6.76	0.68
38.00	13.50	0.68

Param... Inc.
Port of Seattle
554-2912-28B

Miller Creek Low Flow Analysis

Checked By: *[Signature]*
By: Ange... Vilcox
December 6, 2001

Miller Creek Cross Section M-4 Change in Low Flow Water Surface Elevations

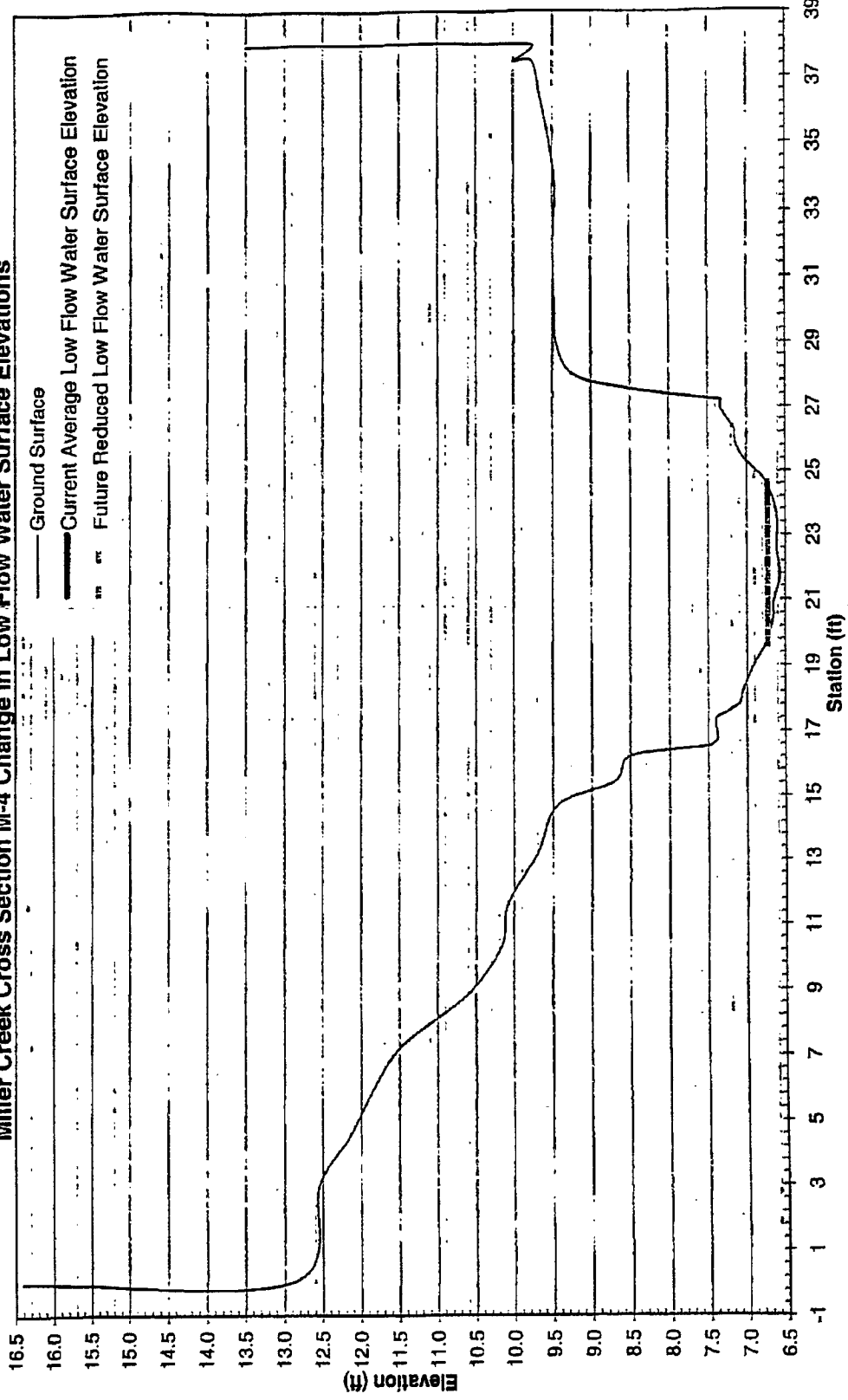

Walker Creek

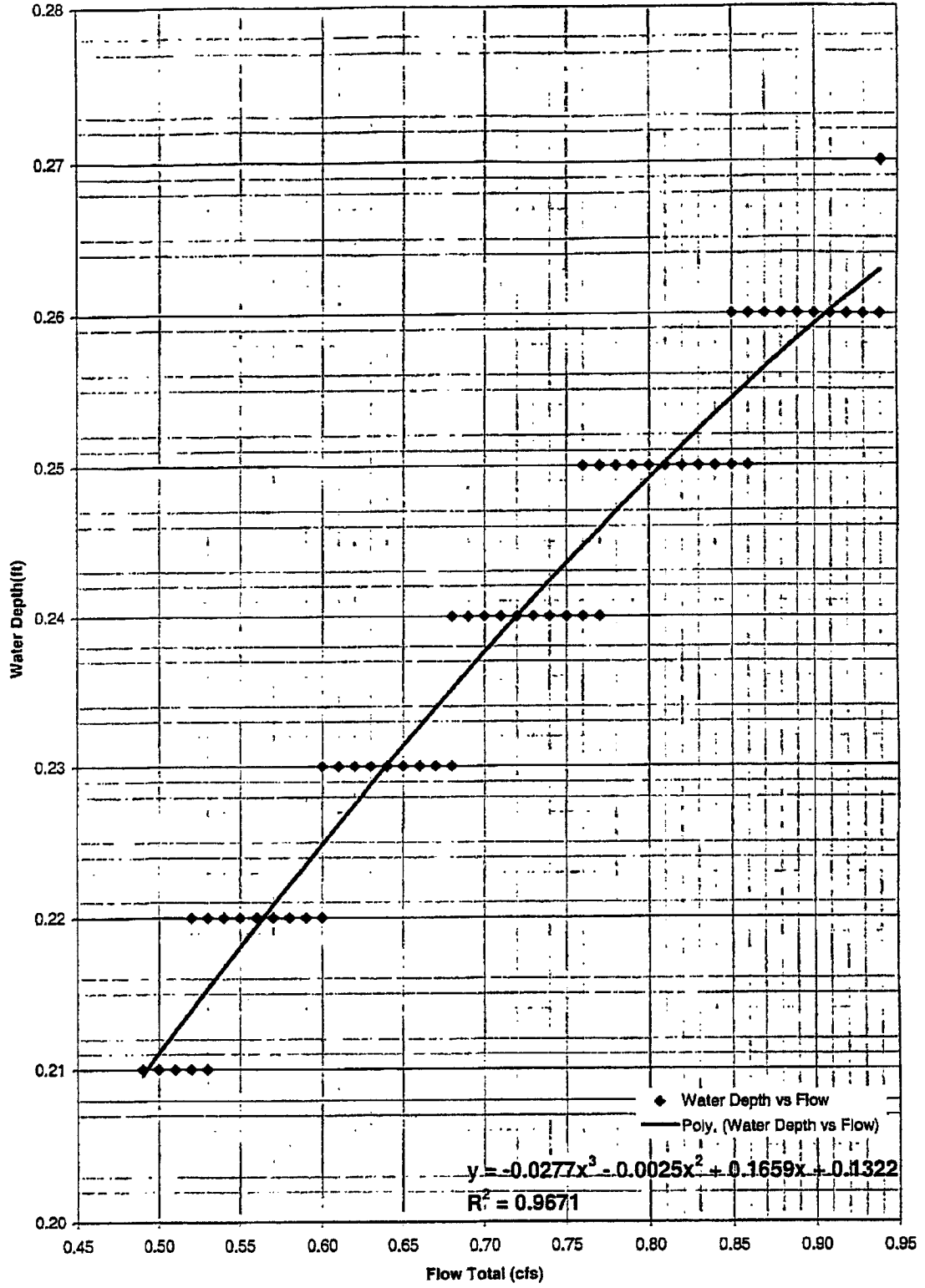

K:\working\29122912(28B)\HecRas Values.xls\Walker Creek D vs H2O Depth

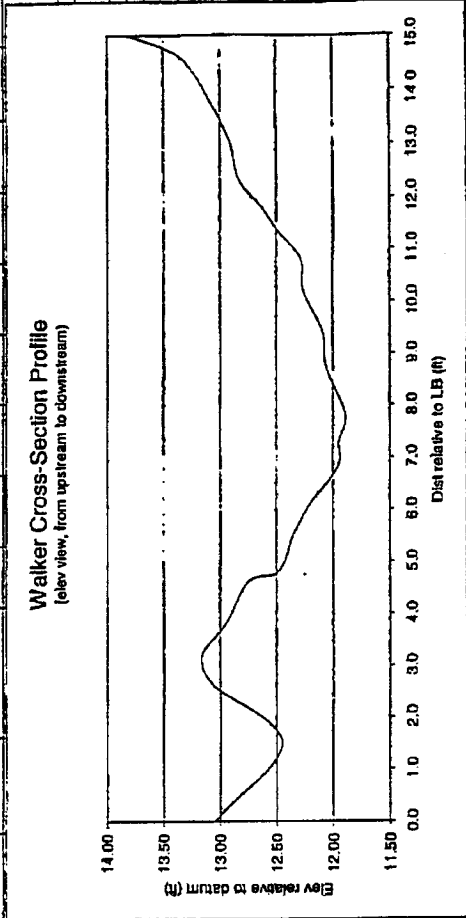
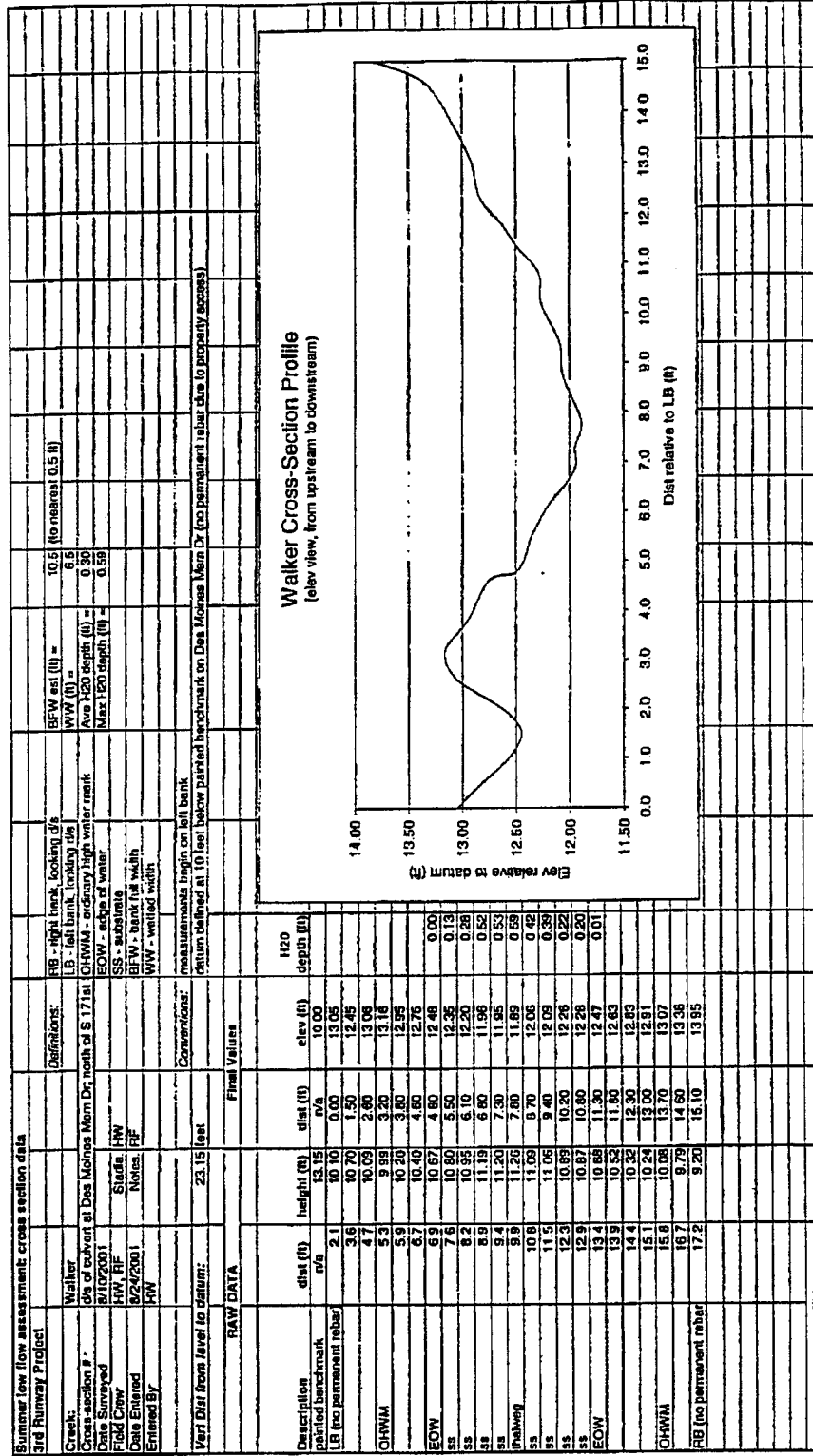

Param... Inc.
Port of Seattle
554-2912-288

Walker Creek Low Flow Analysis

Checked By: *[Signature]*
December 6, 2001

Walker Creek Cross Section W-1 Change in Low Flow Water Surface Elevations

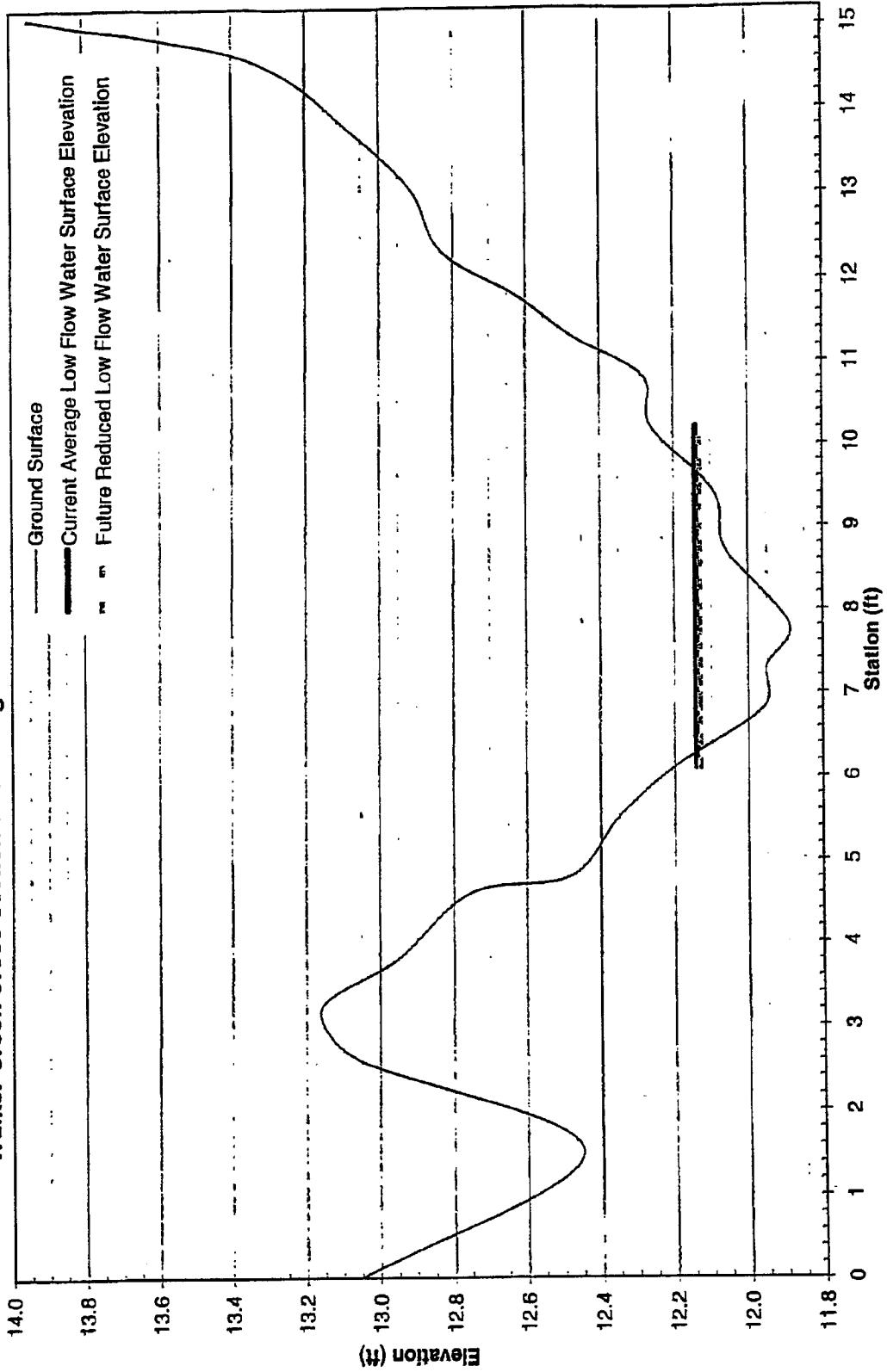

Start of 7-Day Low Flows with
Average Flow Rates

Statistical Ranking of Average 7-Day Low Flows
Period of Record: 1949-1995

Date	No Fill inflow 1994 HSPF Walker Creek Wetland at POC	Date	Average 7-Day Lows Ordered	Rank	Rank/N+1	Return Frequency
17-Oct-49	0.66	1994	0.60	1	0.02	2.1
13-Sep-50	0.83	1979	0.63	2	0.04	4.2
11-Sep-51	0.78	1987	0.64	3	0.06	6.3
15-Nov-52	0.65	1952	0.65	4	0.08	8.3
5-Sep-53	0.76	1993	0.65	5	0.10	10.4
30-Sep-54	0.87	1988	0.65	6	0.13	12.5
23-Aug-55	0.83	1986	0.66	7	0.15	14.6
2-Sep-56	0.85	1949	0.66	8	0.17	16.7
2-Sep-57	0.80	1977	0.66	9	0.19	18.8
10-Sep-58	0.70	1992	0.67	10	0.21	20.8
2-Aug-59	0.85	1985	0.68	11	0.23	22.9
20-Sep-60	0.83	1980	0.68	12	0.25	25.0
4-Sep-61	0.80	1989	0.69	13	0.27	27.1
23-Aug-62	0.79	1958	0.70	14	0.29	29.2
6-Sep-63	0.74	1981	0.70	15	0.31	31.3
8-Aug-64	0.90	1990	0.71	16	0.33	33.3
24-Aug-65	0.78	1976	0.73	17	0.35	35.4
25-Aug-66	0.77	1995	0.73	18	0.38	37.5
15-Aug-67	0.75	1963	0.74	19	0.40	39.6
28-Jun-68	0.94	1973	0.74	20	0.42	41.7
26-Jul-69	0.82	1982	0.75	21	0.44	43.8
2-Sep-70	0.76	1967	0.75	22	0.46	45.8
10-Jul-71	0.88	1970	0.76	23	0.48	47.9
25-Jul-72	0.94	1953	0.76	24	0.50	50.0
24-Jul-73	0.74	1991	0.76	25	0.52	52.1
22-Aug-74	0.77	1966	0.77	26	0.54	54.2
18-Jun-75	0.79	1974	0.77	27	0.56	56.3
15-Oct-76	0.73	1984	0.77	28	0.58	58.3
19-Jun-77	0.66	1951	0.78	29	0.60	60.4
26-Jun-78	0.78	1965	0.78	29	0.60	60.4
6-Aug-79	0.63	1978	0.78	31	0.65	64.6
14-Aug-80	0.68	1962	0.79	32	0.67	66.7
8-Jul-81	0.70	1975	0.79	33	0.69	68.8
23-Jul-82	0.75	1961	0.80	34	0.71	70.8
1-Aug-83	0.90	1957	0.80	35	0.73	72.9
21-Jul-84	0.77	1969	0.82	36	0.75	75.0
27-Jul-85	0.68	1960	0.83	37	0.77	77.1
3-Aug-86	0.66	1950	0.83	38	0.79	79.2
16-Aug-87	0.64	1955	0.83	39	0.81	81.3
18-Jul-88	0.65	1959	0.85	40	0.83	83.3
13-Jul-89	0.69	1956	0.85	41	0.85	85.4
3-Jul-90	0.71	1954	0.87	42	0.88	87.5
3-Aug-91	0.76	1971	0.88	43	0.90	89.6
26-Jul-92	0.67	1964	0.90	44	0.92	91.7
11-Aug-93	0.65	1983	0.90	44	0.92	91.7
18-Jul-94	0.60	1972	0.94	46	0.96	95.8
18-Jun-95	0.73	1968	0.94	47	0.98	97.9

Parametrix Inc.
Port of Seattle
354-2912-286

Des Moines Creek

Checked By: *[Signature]*
By: Angela Wilcox
December 8, 2001

Des Moines Creek @ SR509 HSPF modeling
7 Day Low Flows (1948-1995)

Q_{base min} = 0.17 cfs
Q_{base max} = 0.51 cfs
Change in 2005 = -0.08 cfs

HEC-RAS Plan: D-2 S=0.1% rev.030 River: Des Moines Resch: D-2

River Station	Q (cfs)	Channel Elevation (ft)	Surface Elevation (ft)	Flow Depth (ft)	In Flow Depth (ft)	Velocity Channel (ft/s)	Flow Area (sq ft)	Top Width (ft)	Change in Top Width (ft)
4	0.09	7.77	7.87	0.10	N/A	0.29	0.31	4.41	N/A
4	0.11	7.77	7.88	0.11	N/A	0.31	0.36	4.57	N/A
4	0.13	7.77	7.89	0.12	N/A	0.32	0.41	4.86	N/A
4	0.15	7.77	7.90	0.13	N/A	0.33	0.45	5.09	N/A
4	0.17	7.77	7.91	0.14	0.04	0.35	0.49	5.22	0.81
4	0.19	7.77	7.92	0.15	N/A	0.36	0.53	5.34	N/A
4	0.21	7.77	7.92	0.15	N/A	0.37	0.57	5.45	N/A
4	0.23	7.77	7.93	0.16	N/A	0.38	0.61	5.56	N/A
4	0.25	7.77	7.94	0.17	0.03	0.39	0.64	5.66	0.44
4	0.27	7.77	7.94	0.17	N/A	0.40	0.66	6.43	N/A
4	0.29	7.77	7.95	0.18	N/A	0.41	0.71	6.50	N/A
4	0.31	7.77	7.95	0.18	N/A	0.42	0.75	6.56	N/A
4	0.33	7.77	7.96	0.19	0.02	0.43	0.78	6.61	0.95
4	0.35	7.77	7.96	0.19	N/A	0.44	0.81	6.67	N/A
4	0.37	7.77	7.97	0.20	N/A	0.45	0.84	6.72	N/A
4	0.39	7.77	7.97	0.20	N/A	0.46	0.88	6.78	N/A
4	0.41	7.77	7.98	0.21	0.02	0.47	0.91	6.81	0.20
4	0.43	7.77	7.98	0.21	N/A	0.47	0.94	6.85	N/A
4	0.45	7.77	7.99	0.22	N/A	0.48	0.97	6.89	N/A
4	0.47	7.77	7.99	0.22	N/A	0.49	1.00	6.93	N/A
4	0.49	7.77	7.99	0.22	0.01	0.50	1.02	6.97	0.16
4	0.51	7.77	8.00	0.23	N/A	0.51	1.05	7.01	N/A
3	0.09	7.76	7.86	0.10	N/A	0.29	0.31	4.43	N/A
3	0.11	7.76	7.87	0.11	N/A	0.30	0.36	4.61	N/A
3	0.13	7.76	7.88	0.12	N/A	0.32	0.41	4.90	N/A
3	0.15	7.76	7.89	0.13	N/A	0.33	0.46	5.12	N/A
3	0.17	7.76	7.90	0.14	0.04	0.34	0.50	5.24	0.81
3	0.19	7.76	7.91	0.15	N/A	0.35	0.54	5.36	N/A
3	0.21	7.76	7.92	0.16	N/A	0.36	0.58	5.48	N/A
3	0.23	7.76	7.92	0.16	N/A	0.37	0.62	5.58	N/A
3	0.25	7.76	7.93	0.17	0.03	0.38	0.65	5.68	0.44
3	0.27	7.76	7.93	0.17	N/A	0.40	0.66	6.46	N/A
3	0.29	7.76	7.94	0.18	N/A	0.41	0.72	6.51	N/A
3	0.31	7.76	7.95	0.19	N/A	0.42	0.76	6.57	N/A
3	0.33	7.76	7.95	0.19	0.02	0.42	0.79	6.63	0.95
3	0.35	7.76	7.96	0.20	N/A	0.43	0.82	6.68	N/A
3	0.37	7.76	7.96	0.20	N/A	0.44	0.86	6.74	N/A
3	0.39	7.76	7.96	0.20	N/A	0.45	0.89	6.78	N/A
3	0.41	7.76	7.97	0.21	0.02	0.46	0.92	6.82	0.19
3	0.43	7.76	7.97	0.21	N/A	0.47	0.95	6.86	N/A
3	0.45	7.76	7.98	0.22	N/A	0.48	0.98	6.91	N/A
3	0.47	7.76	7.98	0.22	N/A	0.49	1.01	6.95	N/A
3	0.49	7.76	7.99	0.23	0.02	0.49	1.03	6.99	0.17
3	0.51	7.76	7.99	0.23	N/A	0.50	1.06	7.03	N/A
2	0.09	7.75	7.85	0.10	N/A	0.28	0.32	4.44	N/A
2	0.11	7.75	7.87	0.12	N/A	0.30	0.37	4.65	N/A
2	0.13	7.75	7.88	0.13	N/A	0.31	0.42	4.95	N/A
2	0.15	7.75	7.88	0.13	N/A	0.32	0.46	5.14	N/A
2	0.17	7.75	7.89	0.14	0.04	0.34	0.51	5.27	0.83
2	0.19	7.75	7.90	0.15	N/A	0.35	0.55	5.38	N/A
2	0.21	7.75	7.91	0.16	N/A	0.36	0.59	5.50	N/A
2	0.23	7.75	7.91	0.16	N/A	0.37	0.62	5.61	N/A
2	0.25	7.75	7.92	0.17	0.03	0.38	0.66	6.41	1.14
2	0.27	7.75	7.93	0.18	N/A	0.39	0.70	6.47	N/A
2	0.29	7.75	7.93	0.18	N/A	0.40	0.73	6.53	N/A
2	0.31	7.75	7.94	0.19	N/A	0.41	0.77	6.59	N/A
2	0.33	7.75	7.94	0.19	0.02	0.42	0.80	6.65	0.24
2	0.35	7.75	7.95	0.20	N/A	0.43	0.83	6.70	N/A
2	0.37	7.75	7.95	0.20	N/A	0.44	0.87	6.76	N/A
2	0.39	7.75	7.96	0.21	N/A	0.45	0.90	6.79	N/A
2	0.41	7.75	7.96	0.21	0.02	0.46	0.93	6.84	0.19
2	0.43	7.75	7.97	0.22	N/A	0.48	0.96	6.88	N/A
2	0.45	7.75	7.97	0.22	N/A	0.47	0.99	6.92	N/A
2	0.47	7.75	7.97	0.22	N/A	0.48	1.02	6.96	N/A
2	0.49	7.75	7.98	0.23	0.02	0.49	1.05	7.00	0.16
2	0.51	7.75	7.98	0.23	N/A	0.50	1.07	7.04	N/A
1	0.09	7.74	7.85	0.11	N/A	0.27	0.33	4.46	N/A
1	0.11	7.74	7.86	0.12	N/A	0.29	0.38	4.70	N/A
1	0.13	7.74	7.87	0.13	N/A	0.30	0.43	4.99	N/A
1	0.15	7.74	7.88	0.14	N/A	0.32	0.47	5.16	N/A
1	0.17	7.74	7.88	0.14	0.03	0.33	0.51	5.29	0.83
1	0.19	7.74	7.89	0.15	N/A	0.34	0.55	5.41	N/A
1	0.21	7.74	7.90	0.16	N/A	0.35	0.59	5.52	N/A
1	0.23	7.74	7.91	0.17	N/A	0.36	0.63	5.63	N/A
1	0.25	7.74	7.91	0.17	0.03	0.37	0.67	6.42	1.19
1	0.27	7.74	7.92	0.18	N/A	0.39	0.71	6.49	N/A
1	0.29	7.74	7.92	0.18	N/A	0.40	0.74	6.55	N/A
1	0.31	7.74	7.93	0.19	N/A	0.41	0.78	6.61	N/A
1	0.33	7.74	7.93	0.19	0.02	0.42	0.81	6.66	0.24
1	0.35	7.74	7.94	0.20	N/A	0.42	0.84	6.72	N/A
1	0.37	7.74	7.94	0.20	N/A	0.43	0.88	6.78	N/A
1	0.39	7.74	7.95	0.21	N/A	0.44	0.91	6.81	N/A
1	0.41	7.74	7.95	0.21	0.02	0.45	0.94	6.85	0.19
1	0.43	7.74	7.96	0.22	N/A	0.46	0.97	6.89	N/A
1	0.45	7.74	7.96	0.22	N/A	0.47	1.00	6.94	N/A
1	0.47	7.74	7.97	0.23	N/A	0.48	1.03	6.98	N/A
1	0.49	7.74	7.97	0.23	0.02	0.48	1.06	7.02	0.17
1	0.51	7.74	7.97	0.23	N/A	0.49	1.09	7.05	N/A

Average Change in depth = 0.03 ft Average Change in width = 0.51 ft

Parmentrix Inc.
Port of Seattle
554-2912-2905

Des Moines Creek

Checked By: [Signature]
December 6, 2001

Des Moines Creek @ BR609

HSPP modeling
7 Day Low Flows (1949-1985)

Q_{channel min} = 0.17 cfs
Q_{channel max} = 0.51 cfs
Q_{change in area} = -0.08 cfs

HEC-RAS Plan: D-3 S=0.37% n = 0.025 River: Des Moines Reach: D-3

River Station	Q Total (cfs)	Channel Elevation (ft)	Surface Elevation (ft)	Flow in Depth (ft)	Flow in Velocity (ft/s)	Flow Area (sq ft)	Top Width (ft)	Change in Top Width (ft)	
4	0.09	5.90	6.01	0.11	N/A	0.68	0.15	2.42	N/A
4	0.11	5.90	6.02	0.12	N/A	0.62	0.18	2.65	N/A
4	0.13	5.90	6.03	0.13	N/A	0.64	0.20	2.67	N/A
4	0.15	5.90	6.03	0.13	N/A	0.70	0.22	2.73	N/A
4	0.17	5.90	6.03	0.15	0.04	0.66	0.26	2.92	0.50
4	0.19	5.90	6.05	0.18	N/A	0.73	0.26	2.89	N/A
4	0.21	5.90	6.08	0.18	N/A	0.75	0.28	3.02	N/A
4	0.23	5.90	6.08	0.18	N/A	0.77	0.30	3.10	N/A
4	0.25	5.90	6.07	0.17	0.02	0.79	0.32	3.17	0.25
4	0.27	5.90	6.07	0.17	N/A	0.80	0.34	3.28	N/A
4	0.29	5.90	6.07	0.17	N/A	0.88	0.33	3.23	N/A
4	0.31	5.90	6.08	0.18	N/A	0.89	0.35	3.29	N/A
4	0.33	5.90	6.08	0.18	0.01	0.90	0.36	3.36	0.19
4	0.35	5.90	6.09	0.19	N/A	0.92	0.38	3.42	N/A
4	0.37	5.90	6.09	0.19	N/A	0.93	0.40	3.48	N/A
4	0.39	5.90	6.10	0.20	N/A	0.94	0.41	3.54	N/A
4	0.41	5.90	6.10	0.20	0.02	0.95	0.43	3.60	0.24
4	0.43	5.90	6.11	0.21	N/A	0.97	0.45	3.65	N/A
4	0.45	5.90	6.11	0.21	N/A	0.98	0.46	3.71	N/A
4	0.47	5.90	6.11	0.21	N/A	0.98	0.48	3.78	N/A
4	0.49	5.90	6.12	0.22	0.02	1.00	0.49	3.81	0.21
4	0.51	5.90	6.12	0.22	N/A	1.01	0.50	3.86	N/A
3	0.09	5.88	5.98	0.12	N/A	0.54	0.17	2.49	N/A
3	0.11	5.88	5.99	0.13	N/A	0.59	0.19	2.58	N/A
3	0.13	5.88	5.99	0.13	N/A	0.61	0.19	2.60	N/A
3	0.15	5.88	6.00	0.14	N/A	0.66	0.23	2.78	N/A
3	0.17	5.88	6.01	0.15	0.03	0.70	0.24	2.86	0.37
3	0.19	5.88	6.02	0.16	N/A	0.71	0.27	2.97	N/A
3	0.21	5.88	6.01	0.15	N/A	0.79	0.26	2.95	N/A
3	0.23	5.88	6.03	0.17	N/A	0.74	0.31	3.14	N/A
3	0.25	5.88	6.03	0.17	0.02	0.83	0.30	3.10	0.24
3	0.27	5.88	6.04	0.18	N/A	0.78	0.35	3.29	N/A
3	0.29	5.88	6.04	0.18	N/A	0.85	0.34	3.28	N/A
3	0.31	5.88	6.04	0.18	N/A	0.87	0.36	3.33	N/A
3	0.33	5.88	6.05	0.19	0.02	0.88	0.37	3.39	0.29
3	0.35	5.88	6.05	0.19	N/A	0.90	0.39	3.45	N/A
3	0.37	5.88	6.06	0.20	N/A	0.91	0.41	3.51	N/A
3	0.39	5.88	6.06	0.20	N/A	0.92	0.42	3.57	N/A
3	0.41	5.88	6.07	0.21	0.02	0.93	0.44	3.63	0.24
3	0.43	5.88	6.07	0.21	N/A	0.95	0.45	3.69	N/A
3	0.45	5.88	6.08	0.22	N/A	0.96	0.47	3.74	N/A
3	0.47	5.88	6.08	0.22	N/A	0.97	0.48	3.79	N/A
3	0.49	5.88	6.08	0.22	0.01	0.98	0.50	3.84	0.21
3	0.51	5.88	6.09	0.23	N/A	0.99	0.51	3.87	N/A
2	0.09	5.83	5.93	0.10	N/A	0.63	0.14	2.36	N/A
2	0.11	5.83	5.94	0.11	N/A	0.66	0.17	2.49	N/A
2	0.13	5.83	5.95	0.12	N/A	0.67	0.19	2.63	N/A
2	0.15	5.83	5.97	0.14	N/A	0.62	0.24	2.84	N/A
2	0.17	5.83	5.97	0.14	0.04	0.74	0.23	2.80	0.44
2	0.19	5.83	5.98	0.15	N/A	0.68	0.28	3.01	N/A
2	0.21	5.83	5.98	0.15	N/A	0.77	0.27	2.99	N/A
2	0.23	5.83	5.99	0.16	N/A	0.72	0.32	3.18	N/A
2	0.25	5.83	5.99	0.16	0.02	0.80	0.31	3.14	0.34
2	0.27	5.83	6.01	0.18	N/A	0.76	0.36	3.33	N/A
2	0.29	5.83	6.00	0.17	N/A	0.83	0.35	3.29	N/A
2	0.31	5.83	6.01	0.18	N/A	0.85	0.37	3.36	N/A
2	0.33	5.83	6.01	0.18	0.02	0.86	0.38	3.43	0.29
2	0.35	5.83	6.02	0.19	N/A	0.88	0.40	3.49	N/A
2	0.37	5.83	6.02	0.19	N/A	0.89	0.42	3.55	N/A
2	0.39	5.83	6.03	0.20	N/A	0.90	0.43	3.61	N/A
2	0.41	5.83	6.03	0.20	0.02	0.91	0.45	3.66	0.23
2	0.43	5.83	6.04	0.21	N/A	0.93	0.48	3.72	N/A
2	0.45	5.83	6.04	0.21	N/A	0.94	0.48	3.77	N/A
2	0.47	5.83	6.05	0.22	N/A	0.95	0.50	3.83	N/A
2	0.49	5.83	6.05	0.22	0.02	0.96	0.51	3.88	0.20
2	0.51	5.83	6.06	0.22	N/A	0.97	0.52	3.90	N/A
1	0.09	5.79	5.90	0.11	N/A	0.58	0.16	2.43	N/A
1	0.11	5.79	5.91	0.12	N/A	0.61	0.18	2.55	N/A
1	0.13	5.79	5.92	0.13	N/A	0.64	0.20	2.66	N/A
1	0.15	5.79	5.93	0.14	N/A	0.67	0.22	2.78	N/A
1	0.17	5.79	5.93	0.14	0.03	0.70	0.24	2.88	0.43
1	0.19	5.79	5.94	0.15	N/A	0.72	0.26	2.95	N/A
1	0.21	5.79	5.95	0.16	N/A	0.74	0.28	3.03	N/A
1	0.23	5.79	5.95	0.16	N/A	0.76	0.30	3.11	N/A
1	0.25	5.79	5.96	0.17	0.03	0.78	0.32	3.18	0.32
1	0.27	5.79	5.96	0.17	N/A	0.80	0.34	3.26	N/A
1	0.29	5.79	5.97	0.18	N/A	0.81	0.36	3.33	N/A
1	0.31	5.79	5.97	0.18	N/A	0.83	0.37	3.39	N/A
1	0.33	5.79	5.98	0.19	0.02	0.84	0.39	3.46	0.28
1	0.35	5.79	5.98	0.19	N/A	0.86	0.41	3.52	N/A
1	0.37	5.79	5.99	0.20	N/A	0.87	0.43	3.58	N/A
1	0.39	5.79	5.99	0.20	N/A	0.88	0.44	3.64	N/A
1	0.41	5.79	6.00	0.21	0.02	0.89	0.46	3.70	0.24
1	0.43	5.79	6.00	0.21	N/A	0.91	0.47	3.75	N/A
1	0.45	5.79	6.01	0.22	N/A	0.92	0.49	3.81	N/A
1	0.47	5.79	6.01	0.22	N/A	0.93	0.51	3.86	N/A
1	0.49	5.79	6.01	0.22	0.01	0.94	0.52	3.89	0.19
1	0.51	5.79	6.02	0.23	N/A	0.95	0.53	3.92	N/A

Des Moines Creek Average Change in Depth = 0.03 ft (9 mm)
Des Moines Creek Average Change in Width = 0.33 ft (101 mm)

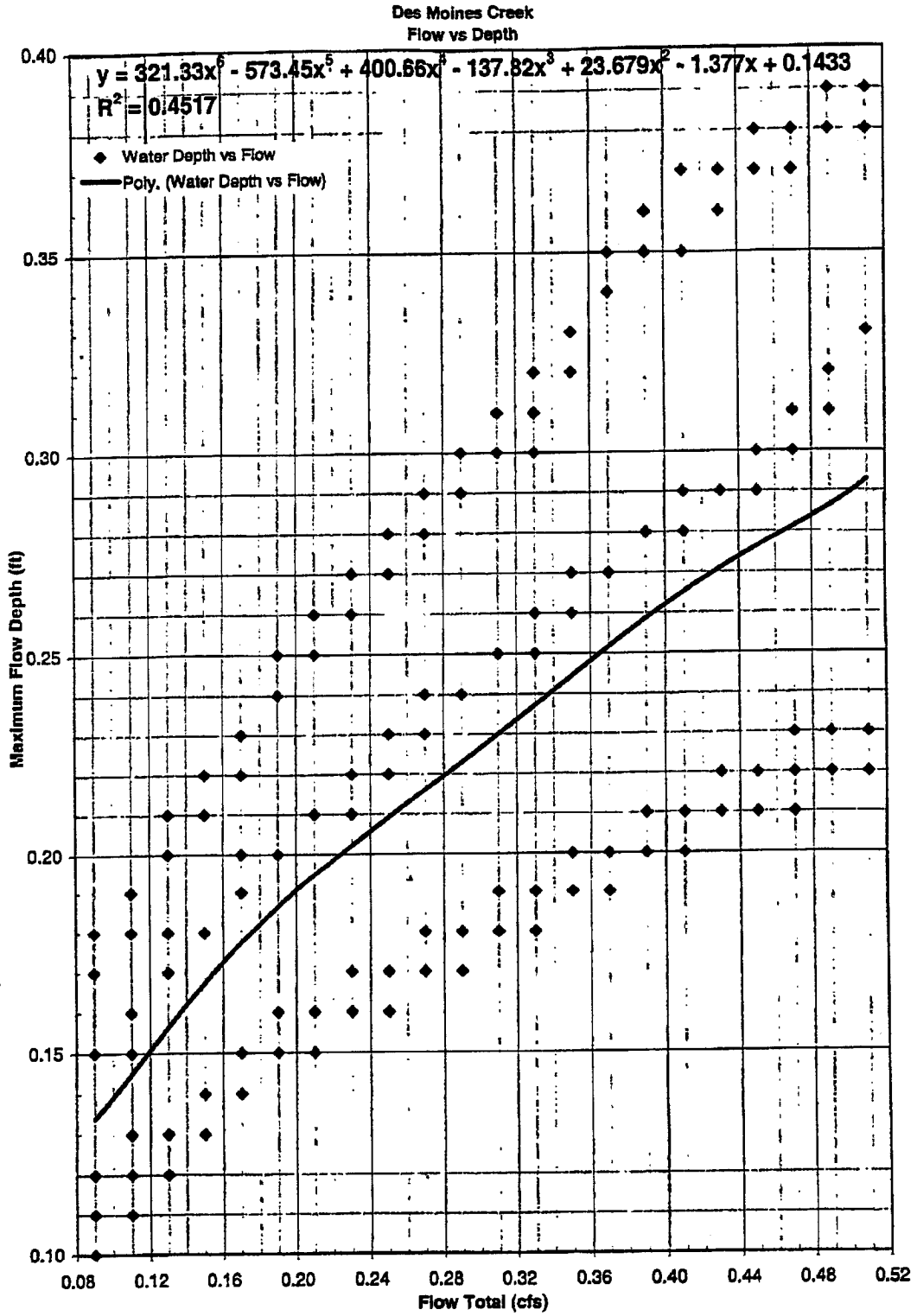

K:\working\2912\2912(28B)\HecRes Values.xls\Des Moines Q vs H2O Depth

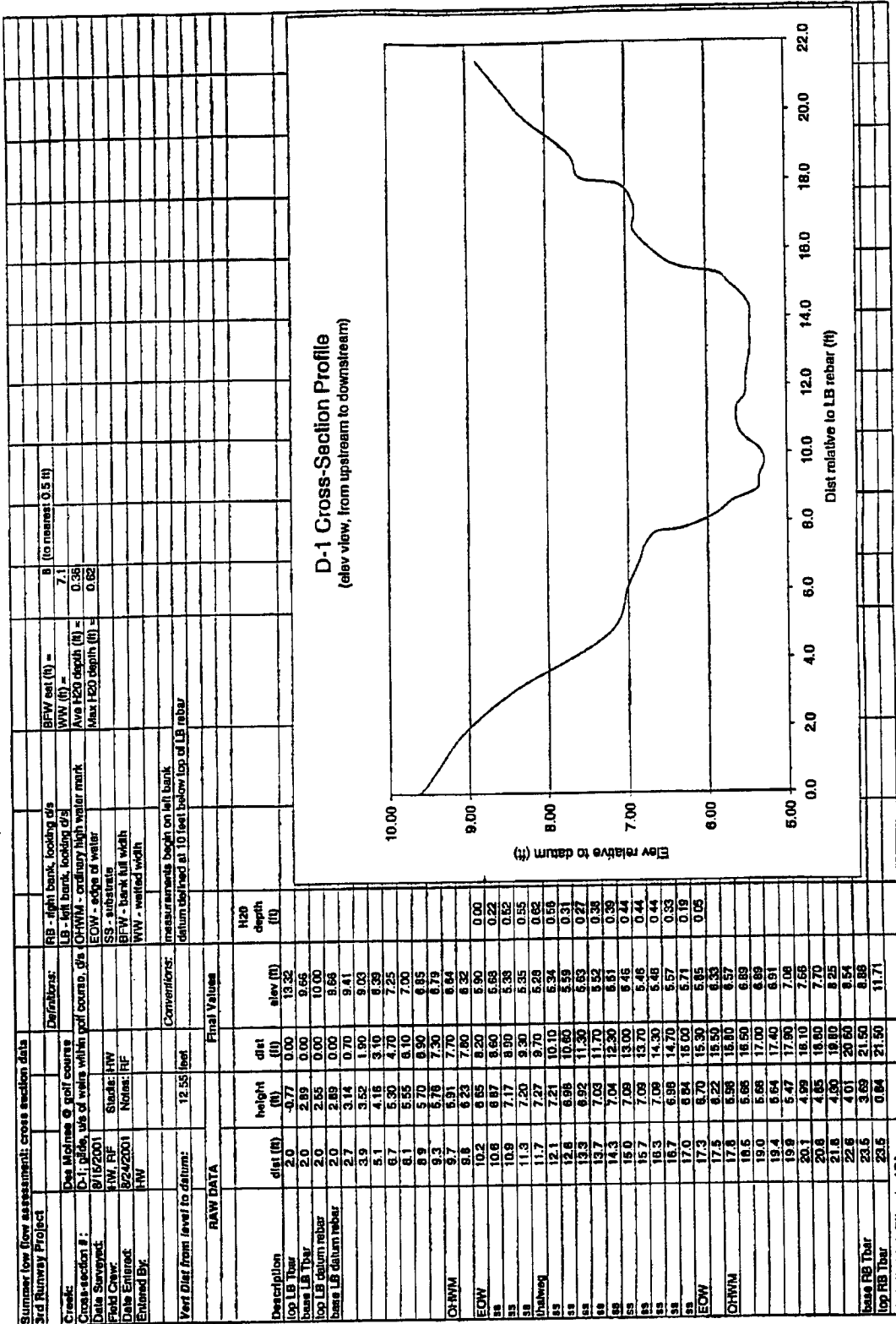

Summer low flow assessment: cross section data		Definitions:	
3rd Runway Project	Dea Moinee @ golf course	RB - right bank, looking g/s	BRW set (ft) =
Creek:	D-1, pipe, vs of wells within pool course, g/s	LB - left bank, looking g/s	WW (ft) =
Cross-section #:	8/15/2001	CHWM - ordinary high water mark	Ave H2O depth (ft) =
Date Surveyed:	8/24/2001	ECW - edge of water	Max H2O depth (ft) =
Field Crew:	SW, RF	SS - substrate	
Date Entreat:	Notes: RF	BFW - bank full width	
Entered By:	RF	WW - wetted width	
Vert Dist from level to datum:	12.55 feet	Conventions:	
RAW DATA		measurements begin on left bank datum defined at 10 feet below top of LB rebar	
Final Values			
Description	dist (ft)	height (ft)	H2O depth (ft)
top LB rebar	0.00	13.32	
base LB rebar	2.0	9.66	
top LB datum rebar	2.0	10.00	
base LB datum rebar	2.0	9.66	
	2.7	9.41	
	3.9	9.03	
	5.1	8.99	
	6.7	7.25	
	8.1	7.00	
	8.9	6.95	
	9.3	6.79	
	9.7	6.84	
	8.8	6.32	
	10.2	5.90	
	10.6	5.68	
	10.9	5.33	
	11.3	5.32	
	11.7	5.29	
	12.1	5.34	
	12.6	5.31	
	13.3	5.27	
	13.7	5.38	
	14.3	5.39	
	15.0	5.45	
	15.7	5.46	
	16.3	5.48	
	16.7	5.57	
	17.0	5.71	
	17.3	5.95	
	17.5	6.33	
	17.8	6.57	
	18.5	6.89	
	19.0	6.89	
	19.4	6.91	
	19.8	7.08	
	20.1	7.68	
	20.8	7.70	
	21.8	8.25	
	22.6	8.54	
base RB rebar	23.5	8.88	
top RB rebar	23.5	11.71	

Parsons, Inc.
Port of Seattle
554-2912-28B

Checked By: *[Signature]*
By: Angela Wilcox
December 6, 2001

Des Moines Creek Cross Section D-1 Change In Low Flow Water Surface Elevations

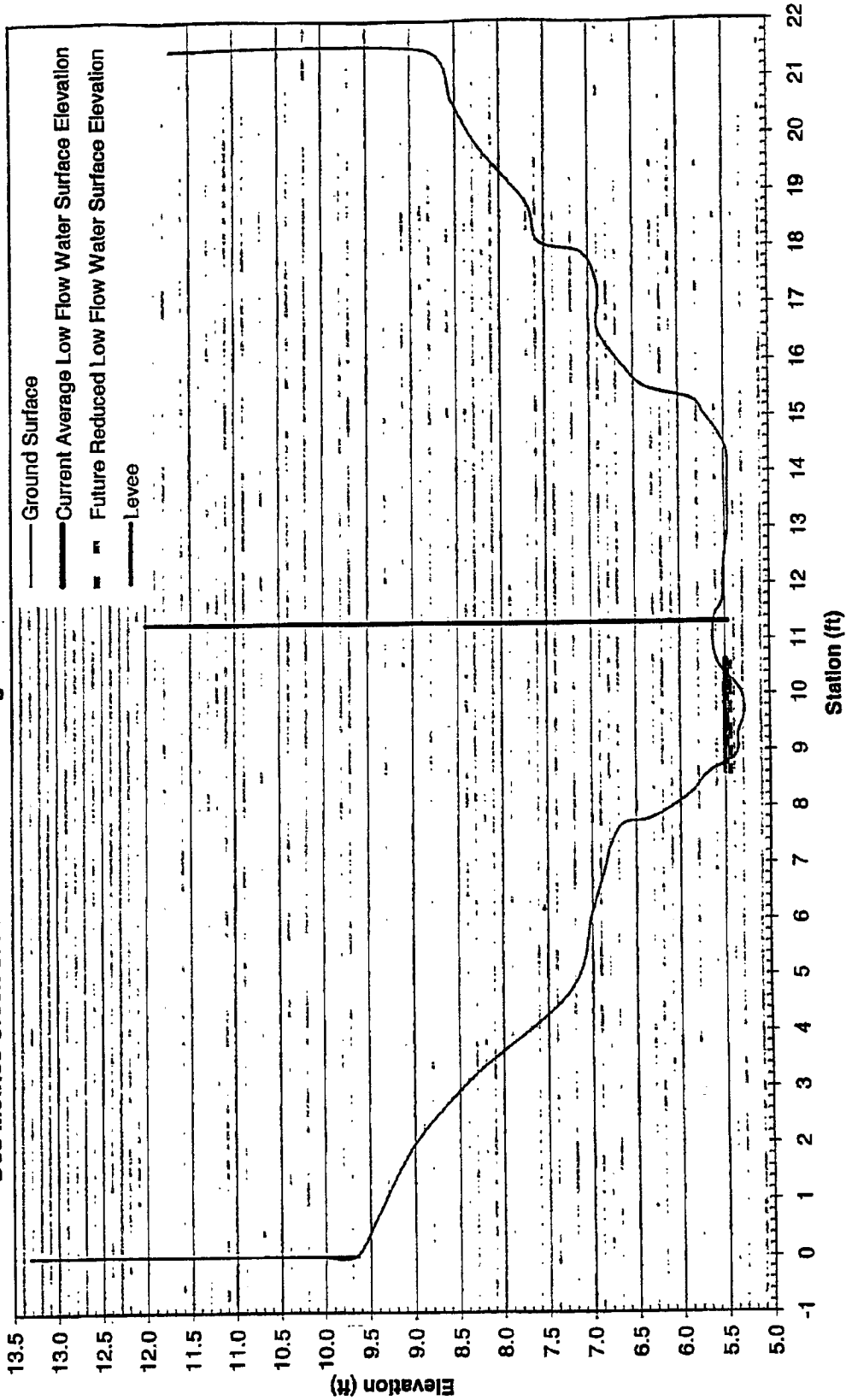

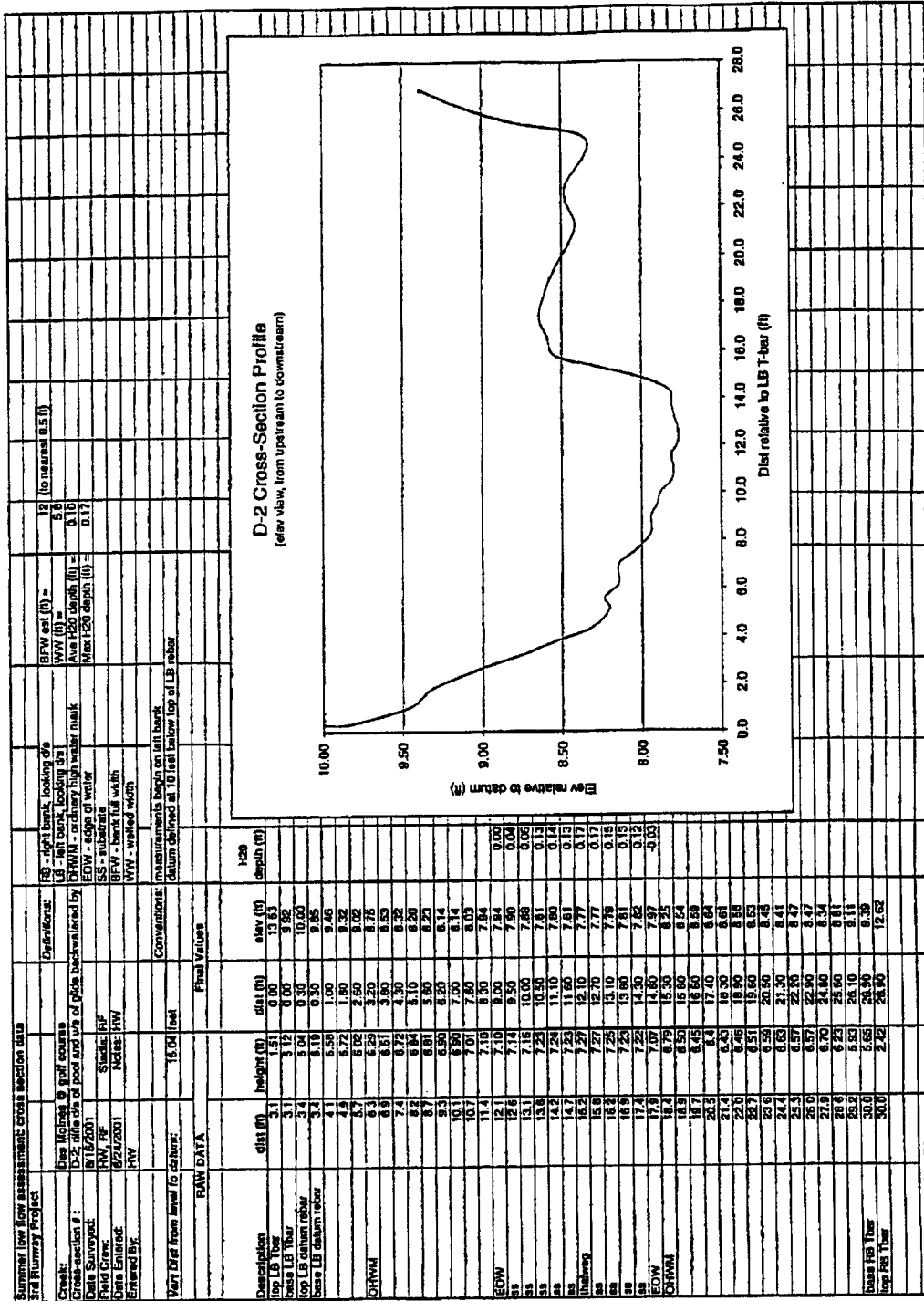

Summer low flow assessment cross section data		Description		Dist (ft)		Elev (ft)		Dist (ft)		Elev (ft)	
Dist	Height	Dist	Height	Dist	Height	Dist	Height	Dist	Height	Dist	Height
0.0	8.50	0.0	8.50	0.0	8.50	0.0	8.50	0.0	8.50	0.0	8.50
1.0	8.50	1.0	8.50	1.0	8.50	1.0	8.50	1.0	8.50	1.0	8.50
2.0	8.50	2.0	8.50	2.0	8.50	2.0	8.50	2.0	8.50	2.0	8.50
3.0	8.50	3.0	8.50	3.0	8.50	3.0	8.50	3.0	8.50	3.0	8.50
4.0	8.50	4.0	8.50	4.0	8.50	4.0	8.50	4.0	8.50	4.0	8.50
5.0	8.50	5.0	8.50	5.0	8.50	5.0	8.50	5.0	8.50	5.0	8.50
6.0	8.50	6.0	8.50	6.0	8.50	6.0	8.50	6.0	8.50	6.0	8.50
7.0	8.50	7.0	8.50	7.0	8.50	7.0	8.50	7.0	8.50	7.0	8.50
8.0	8.50	8.0	8.50	8.0	8.50	8.0	8.50	8.0	8.50	8.0	8.50
9.0	8.50	9.0	8.50	9.0	8.50	9.0	8.50	9.0	8.50	9.0	8.50
10.0	8.50	10.0	8.50	10.0	8.50	10.0	8.50	10.0	8.50	10.0	8.50
11.0	8.50	11.0	8.50	11.0	8.50	11.0	8.50	11.0	8.50	11.0	8.50
12.0	8.50	12.0	8.50	12.0	8.50	12.0	8.50	12.0	8.50	12.0	8.50
13.0	8.50	13.0	8.50	13.0	8.50	13.0	8.50	13.0	8.50	13.0	8.50
14.0	8.50	14.0	8.50	14.0	8.50	14.0	8.50	14.0	8.50	14.0	8.50
15.0	8.50	15.0	8.50	15.0	8.50	15.0	8.50	15.0	8.50	15.0	8.50
16.0	8.50	16.0	8.50	16.0	8.50	16.0	8.50	16.0	8.50	16.0	8.50
17.0	8.50	17.0	8.50	17.0	8.50	17.0	8.50	17.0	8.50	17.0	8.50
18.0	8.50	18.0	8.50	18.0	8.50	18.0	8.50	18.0	8.50	18.0	8.50
19.0	8.50	19.0	8.50	19.0	8.50	19.0	8.50	19.0	8.50	19.0	8.50
20.0	8.50	20.0	8.50	20.0	8.50	20.0	8.50	20.0	8.50	20.0	8.50
21.0	8.50	21.0	8.50	21.0	8.50	21.0	8.50	21.0	8.50	21.0	8.50
22.0	8.50	22.0	8.50	22.0	8.50	22.0	8.50	22.0	8.50	22.0	8.50
23.0	8.50	23.0	8.50	23.0	8.50	23.0	8.50	23.0	8.50	23.0	8.50
24.0	8.50	24.0	8.50	24.0	8.50	24.0	8.50	24.0	8.50	24.0	8.50
25.0	8.50	25.0	8.50	25.0	8.50	25.0	8.50	25.0	8.50	25.0	8.50
26.0	8.50	26.0	8.50	26.0	8.50	26.0	8.50	26.0	8.50	26.0	8.50
27.0	8.50	27.0	8.50	27.0	8.50	27.0	8.50	27.0	8.50	27.0	8.50
28.0	8.50	28.0	8.50	28.0	8.50	28.0	8.50	28.0	8.50	28.0	8.50

Paramet... inc.
Port of Seattle
554-2912-28B

Des Moines Creek Low Flow Analysis

Checked By: *[Signature]*
By: Angela Vitcox
December 6, 2001

Des Moines Creek Cross Section D-2 Change in Low Flow Water Surface Elevations

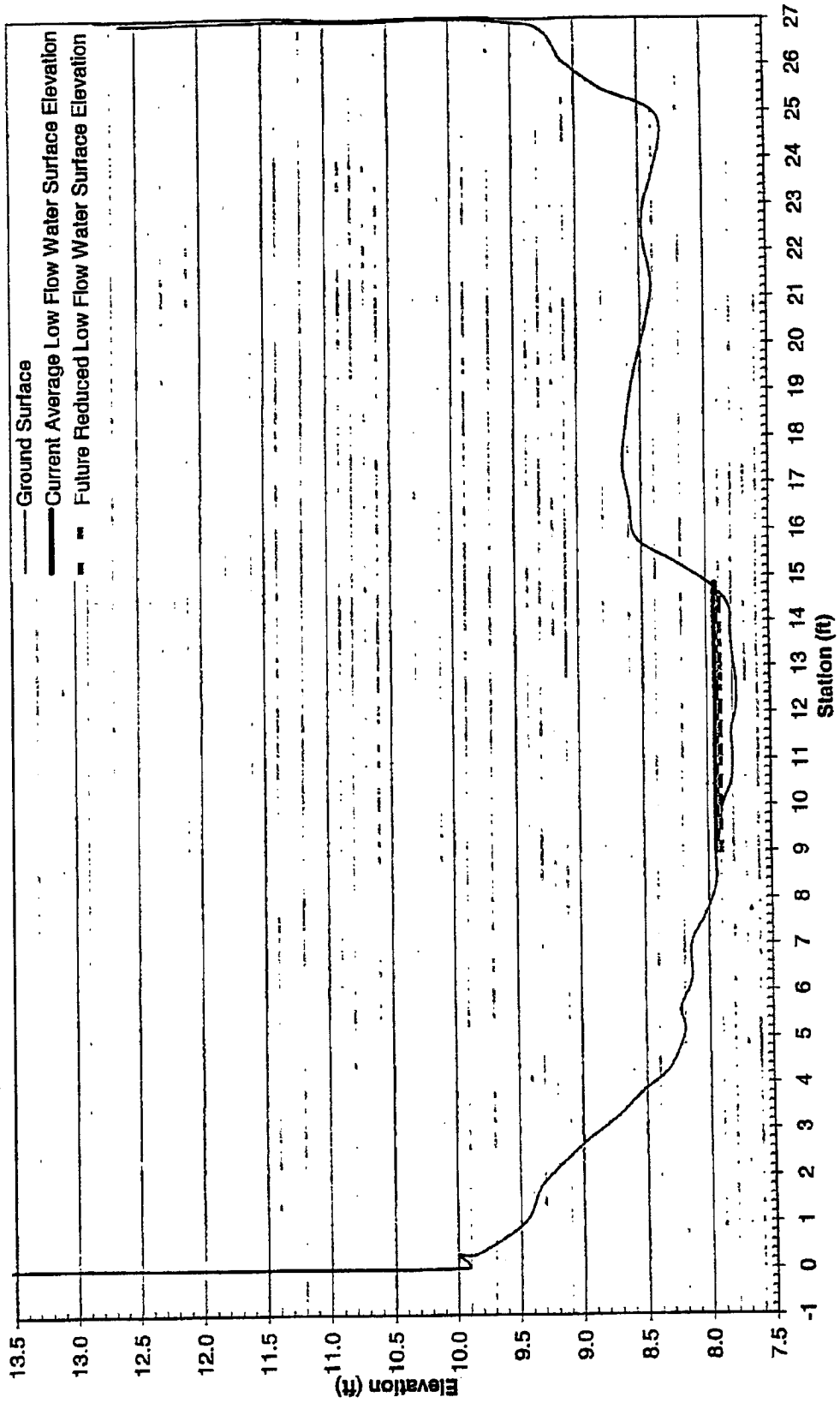

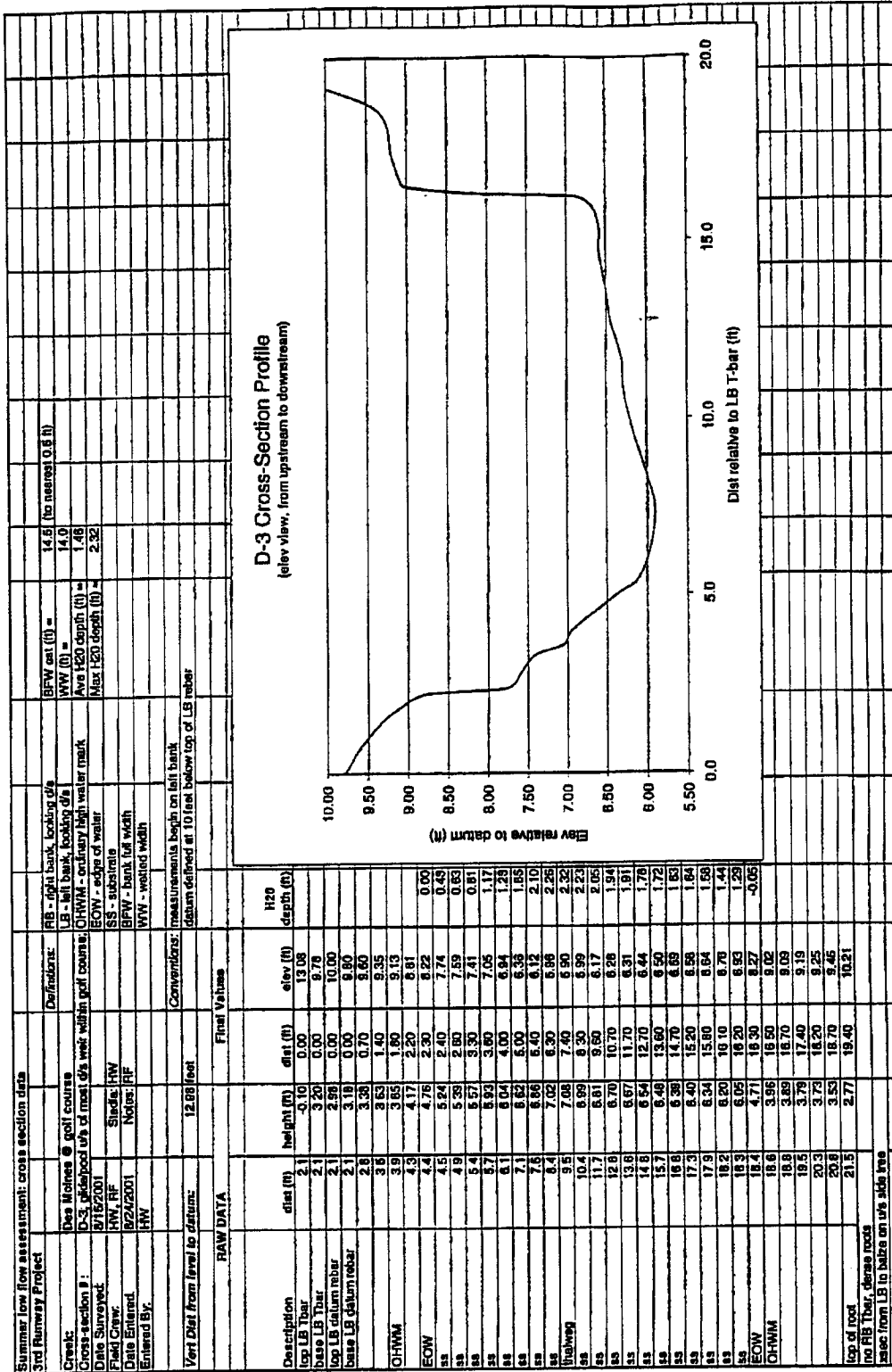

Parallell, Inc.
Port of Seattle
554-2912-28B

Checked By: *[Signature]*
By: Angel Alcox
December 6, 2001

Des Moines Creek Cross Section D-3 Change in Low Flow Water Surface Elevations

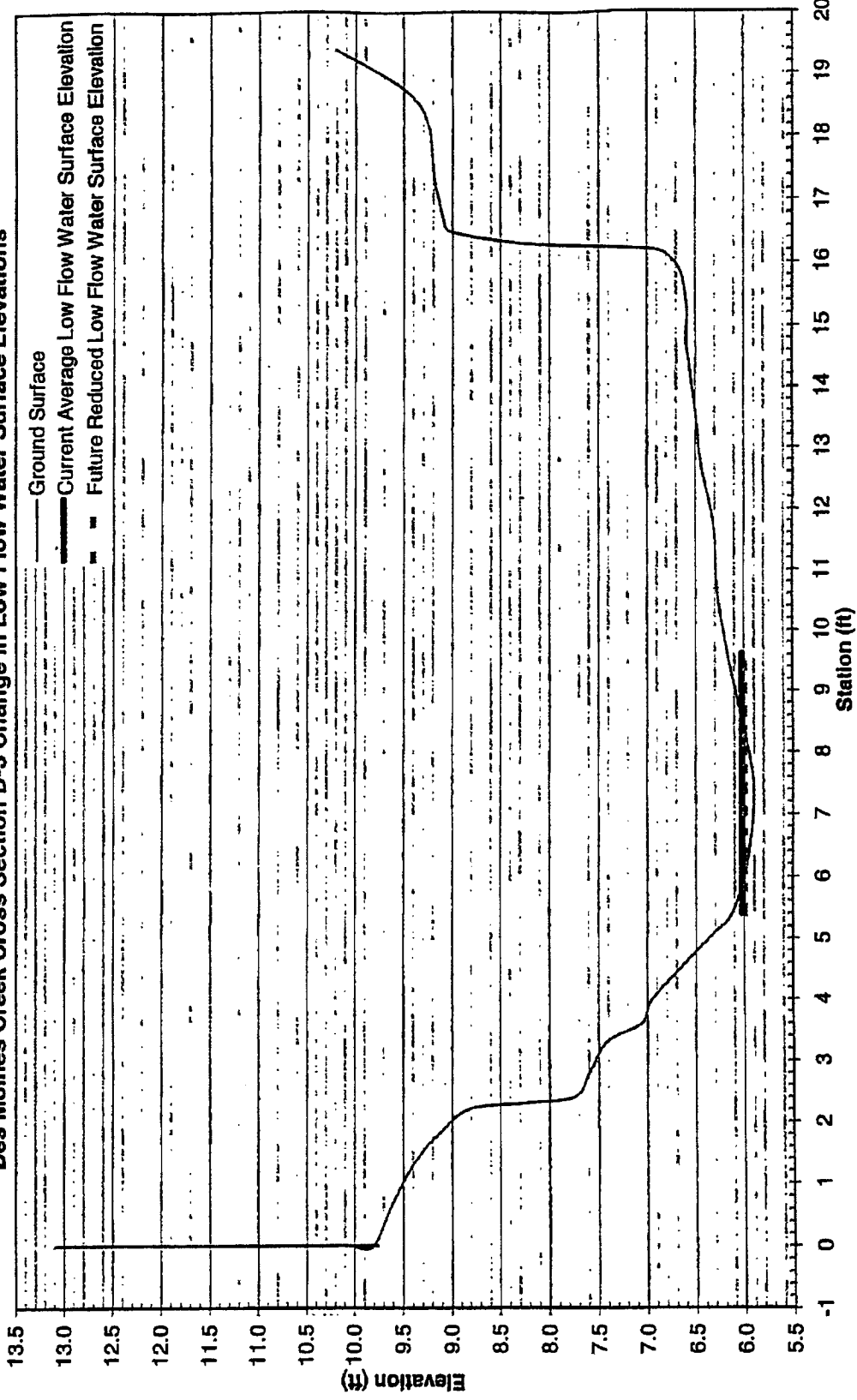

Start of 7-Day Low Flows
with Average Flow Rates

Statistical Ranking of Average 7-Day Low Flows
Period of Record: 1949 - 1995

1994 HSPF Des Moines Creek at 200th St. / Flow cfs				Statistical Ranking of Average 7-Day Low Flows Period of Record: 1949 - 1995				
Date		Average 7-Day Low Flow		Year	Average 7-Day Lows Ordered	Rank	Rank/(47+1)	Return Frequency
1949	Sep	7	0.18	1977	0.17	1	0.02	2.1
1950	Sep	17	0.40	1949	0.18	2	0.04	4.2
1951	Aug	20	0.35	1952	0.21	3	0.06	6.3
1952	Oct	13	0.21	1994	0.22	4	0.08	8.3
1953	Sep	15	0.35	1979	0.22	5	0.10	10.4
1954	Aug	7	0.48	1988	0.25	6	0.13	12.5
1955	Sep	6	0.34	1985	0.25	7	0.15	14.6
1956	Sep	3	0.43	1986	0.26	8	0.17	16.7
1957	Sep	20	0.32	1993	0.27	9	0.19	18.8
1958	Sep	2	0.27	1973	0.27	10	0.21	20.8
1959	Aug	24	0.38	1958	0.27	11	0.23	22.9
1960	Aug	7	0.39	1981	0.28	12	0.25	25.0
1961	Aug	23	0.40	1987	0.29	13	0.27	27.1
1962	Sep	2	0.33	1990	0.31	14	0.29	29.2
1963	Sep	27	0.36	1974	0.31	15	0.31	31.3
1964	Aug	31	0.47	1992	0.31	16	0.33	33.3
1965	Aug	3	0.38	1966	0.32	17	0.35	35.4
1966	Aug	20	0.32	1957	0.32	18	0.38	37.5
1967	Aug	25	0.33	1970	0.33	19	0.40	39.6
1968	Aug	6	0.47	1975	0.33	20	0.42	41.7
1969	Sep	6	0.38	1962	0.33	21	0.44	43.8
1970	Aug	27	0.33	1980	0.33	22	0.46	45.8
1971	Aug	14	0.41	1991	0.33	22	0.46	45.8
1972	Oct	18	0.51	1967	0.33	24	0.50	50.0
1973	Sep	12	0.27	1976	0.34	25	0.52	52.1
1974	Oct	13	0.31	1955	0.34	26	0.54	54.2
1975	Aug	11	0.33	1951	0.35	27	0.56	56.3
1976	Oct	17	0.34	1995	0.35	27	0.56	56.3
1977	Aug	16	0.17	1953	0.35	29	0.60	60.4
1978	Oct	16	0.41	1989	0.35	30	0.63	62.5
1979	Aug	7	0.22	1984	0.36	31	0.65	64.6
1980	Aug	23	0.33	1963	0.36	32	0.67	66.7
1981	Sep	12	0.28	1965	0.38	33	0.69	68.8
1982	Aug	6	0.41	1989	0.38	34	0.71	70.8
1983	Oct	10	0.45	1959	0.38	35	0.73	72.9
1984	Aug	29	0.36	1960	0.39	36	0.75	75.0
1985	Aug	30	0.25	1961	0.40	37	0.77	77.1
1986	Sep	10	0.26	1950	0.40	38	0.79	79.2
1987	Sep	7	0.29	1971	0.41	39	0.81	81.3
1988	Sep	11	0.25	1978	0.41	40	0.83	83.3
1989	Oct	3	0.35	1982	0.41	41	0.85	85.4
1990	Sep	25	0.31	1956	0.43	42	0.88	87.5
1991	Oct	9	0.33	1983	0.45	43	0.90	89.6
1992	Sep	1	0.31	1964	0.47	44	0.92	91.7
1993	Sep	29	0.27	1988	0.47	44	0.92	91.7
1994	Aug	26	0.22	1954	0.48	46	0.96	95.8
1995	Sep	20	0.35	1972	0.51	47	0.98	97.9

Rank = Numerical position of ordered average 7-day low flow
values with the driest year equal to one.
N = 47

AR 020051



APPENDIX F
RESERVE STORMWATER RELEASE STORAGE FACILITIES
CONCEPT DRAWINGS

AR 020053



Seattle Tacoma International Airport

Low Flow Analysis Flow Impact Offset Facility Proposal

RESERVE STORMWATER RELEASE STORAGE FACILITIES CONCEPT DRAWINGS

Prepared By



Checked By

Alan D. Black P.E.

AR 020054

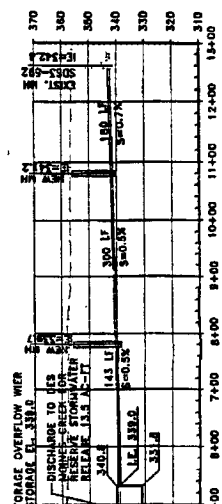
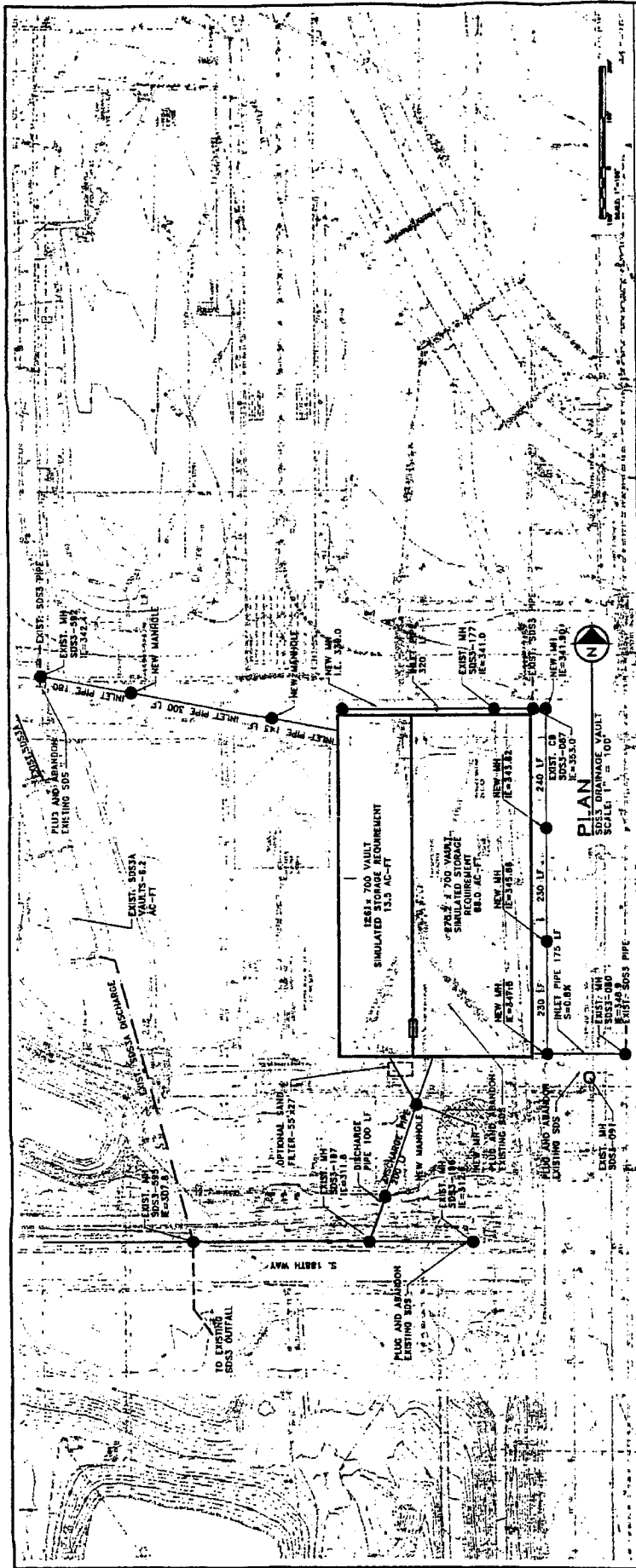

SECTION
 SDS3 DRAINAGE VAULT
 SCALE: HORIZ. 1" = 100'
 VERT. 1" = 20'

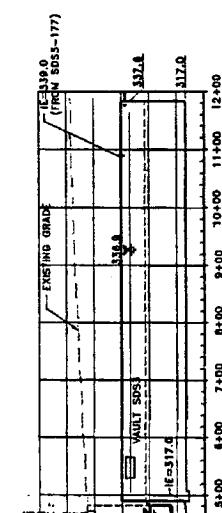

PROFILE
 SDS3 DRAINAGE VAULT
 SCALE: HORIZ. 1" = 100'
 VERT. 1" = 20'

FIRM OF RECORD
 BRASCO INTERNATIONAL AIRPORT
 PROJECT: THIRD RUNWAY - ENHANCEMENT CONSTRUCTION
 SHEET NO. **SDS3, SDS3A AND SDS8**
BASIN VAULT / PLAN AND PROFILE
 DEC. 8, 2001
 EXHIBIT - C141

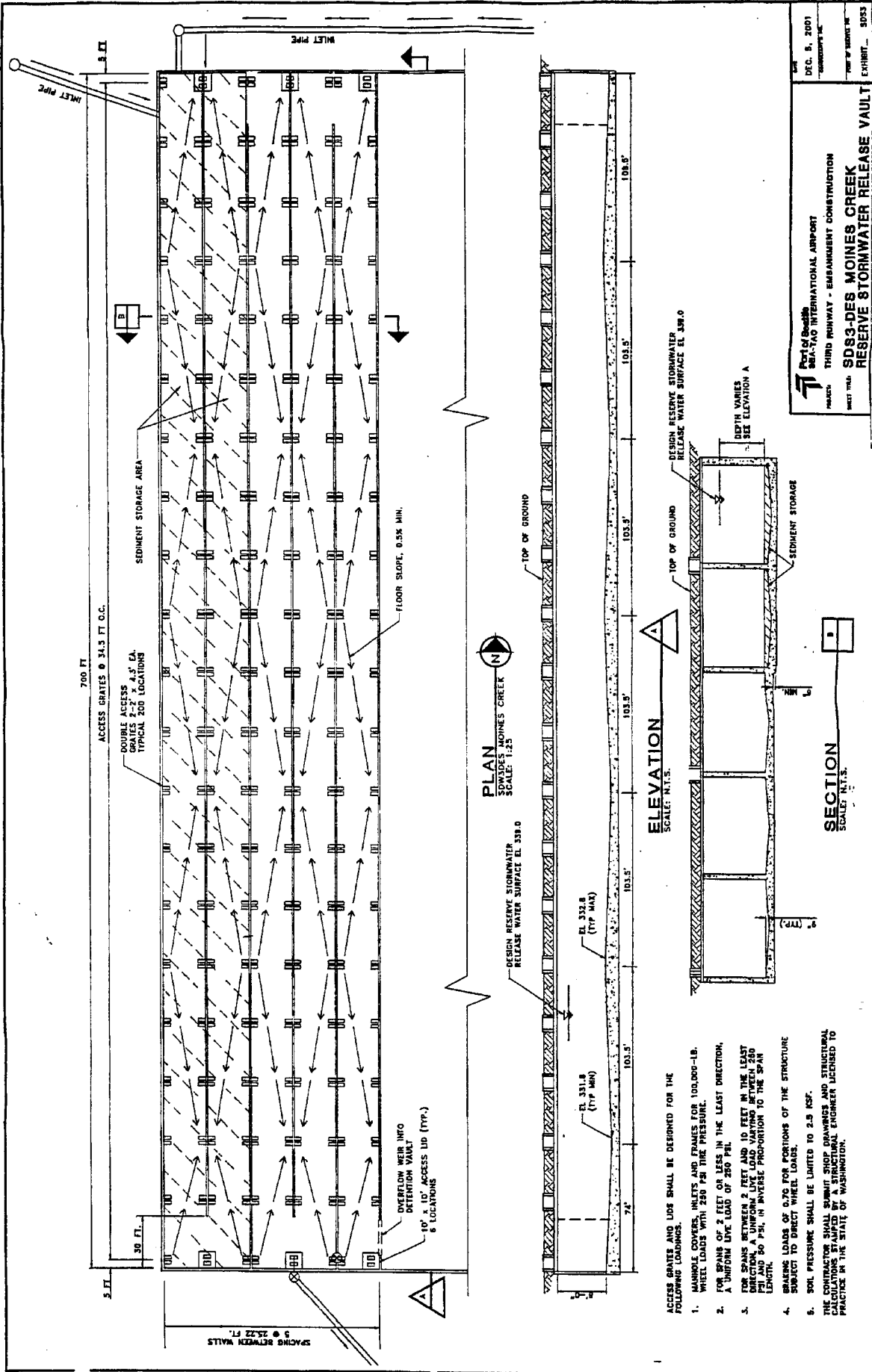

- ACCESS GRATES AND LIDS SHALL BE DESIGNED FOR THE FOLLOWING LOADINGS.
1. MANHOLE COVERS, INLETS AND FRAMES FOR 100,000-LB. WHEEL LOADS WITH 250 PSI THE PRESSURE.
 2. FOR SPANS OF 2 FEET OR LESS IN THE LEAST DIRECTION, A UNIFORM LIVE LOAD OF 250 PSF.
 3. FOR SPANS BETWEEN 2 FEET AND 10 FEET IN THE LEAST DIRECTION, A UNIFORM LIVE LOAD VARYING BETWEEN 250 PSF AND 80 PSF, IN INVERSE PROPORTION TO THE SPAN LENGTH.
 4. BRACING LOADS OF 0.75 FOR PORTIONS OF THE STRUCTURE SUBJECT TO DIRECT WHEEL LOADS.
 5. SOIL PRESSURE SHALL BE LIMITED TO 2.5 KSF.
- THE CONTRACTOR SHALL SUBMIT SHOP DRAWINGS AND STRUCTURAL CALCULATIONS STAMPED BY A STRUCTURAL ENGINEER LICENSED TO PRACTICE IN THE STATE OF WASHINGTON.

DEC. 5, 2001
 PORT OF SPOKANE
 SPAN-TAD INTERNATIONAL AIRPORT
 PHASE 3
 THIRD RUNWAY - EMPANMENT CONSTRUCTION
 SDSA-DES MOINES CREEK
 RESERVE STORMWATER RELEASE VAULT
 SHEET NO. SD03
 EXHIBIT - SD03

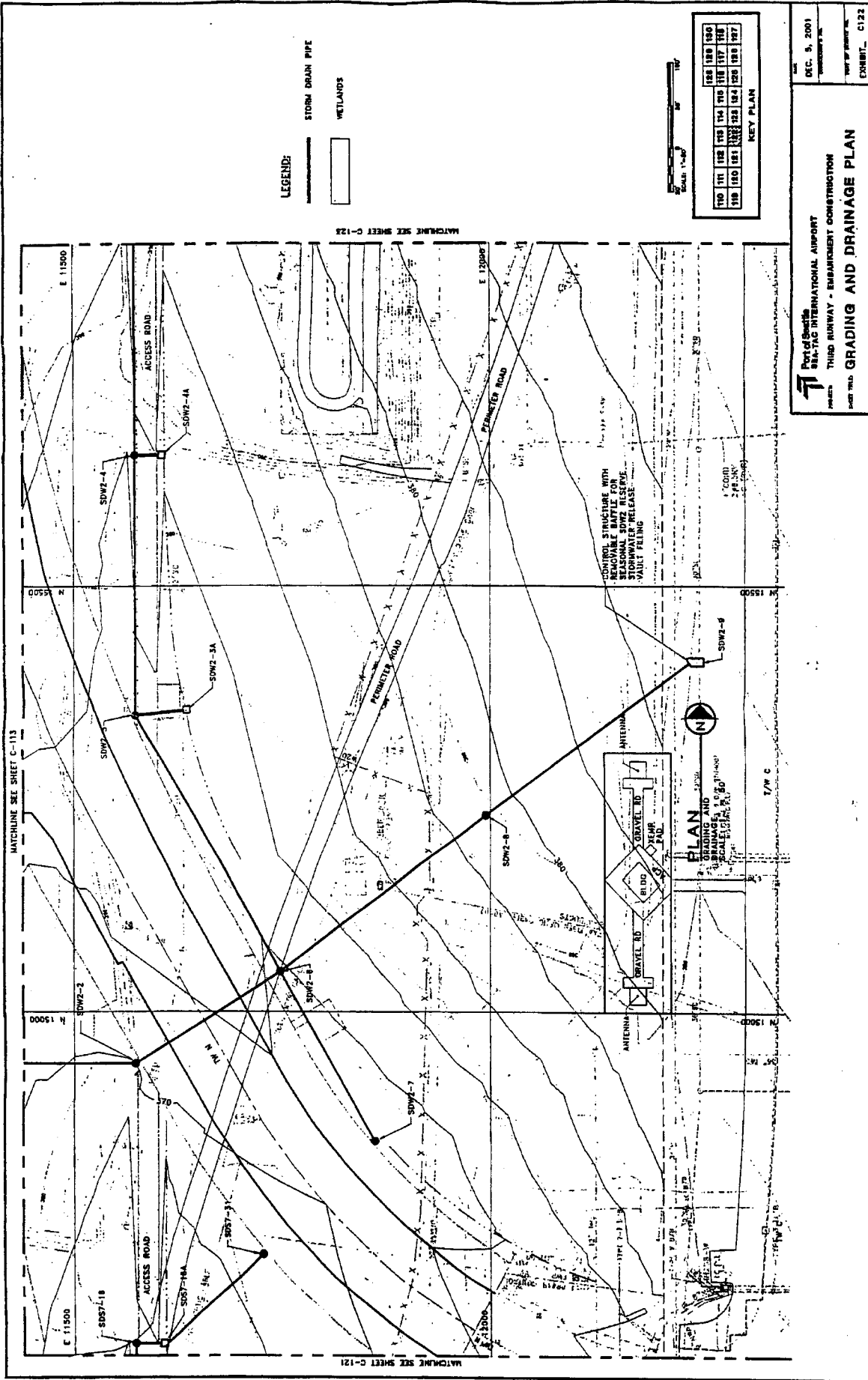

Port of Seattle
 SEA-TAC INTERNATIONAL AIRPORT
 PROJECT: THIRD RUNWAY - EMBARKMENT CONSTRUCTION
 SHEET NO. **GRADING AND DRAINAGE PLAN**
 DATE: DEC. 5, 2001
 EXHIBIT: C122

- NOTES**
- GROUND WATER ELEVATIONS ARE APPROXIMATE BASED ON AVAILABLE GEOTECHNICAL INVESTIGATIONS AND INTERPOLATED ELEVATION WILL BE INCLUDED AS PART OF THE FINAL DESIGN ANNEXURE.
 - FINAL POND CONFIGURATION MAY VARY TO MAINTAIN WATER STORAGE ABOVE THE OBSERVED GROUND WATER.

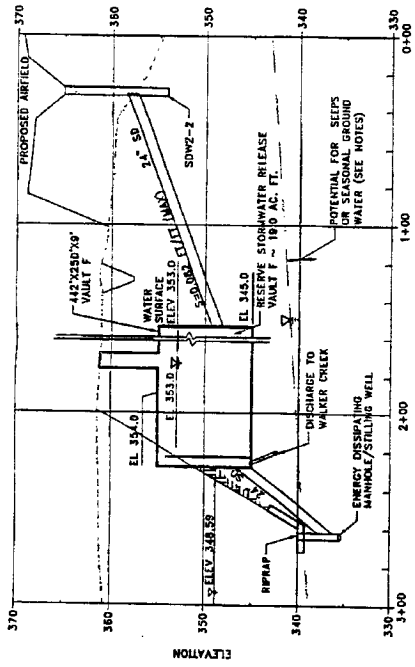

PROFILE 2
STORMWATER RELEASE VAULT PROFILE
 SCALE: HORIZ 1" = 30'
 VERT 1" = 6'

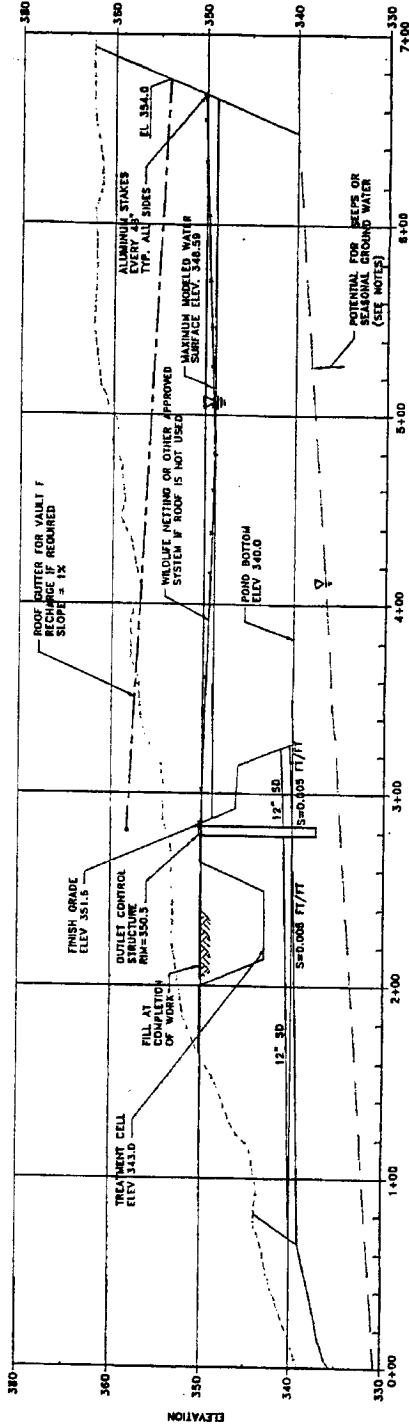

PROFILE 1
SDW-2 BASIN POND
 SCALE: HORIZ 1" = 30'
 VERT 1" = 6'

GROUND WATER AT ELEV. 280s

Part of Seattle
 SEA-TAC INTERNATIONAL AIRPORT
 PROJECT THIRD RUNWAY - EMBANKMENT CONSTRUCTION
 SHEET TITLE
POND F PROFILE
SDW2 BASIN POND
 DATE DEC. 5, 2001
 EXHIBIT_C132

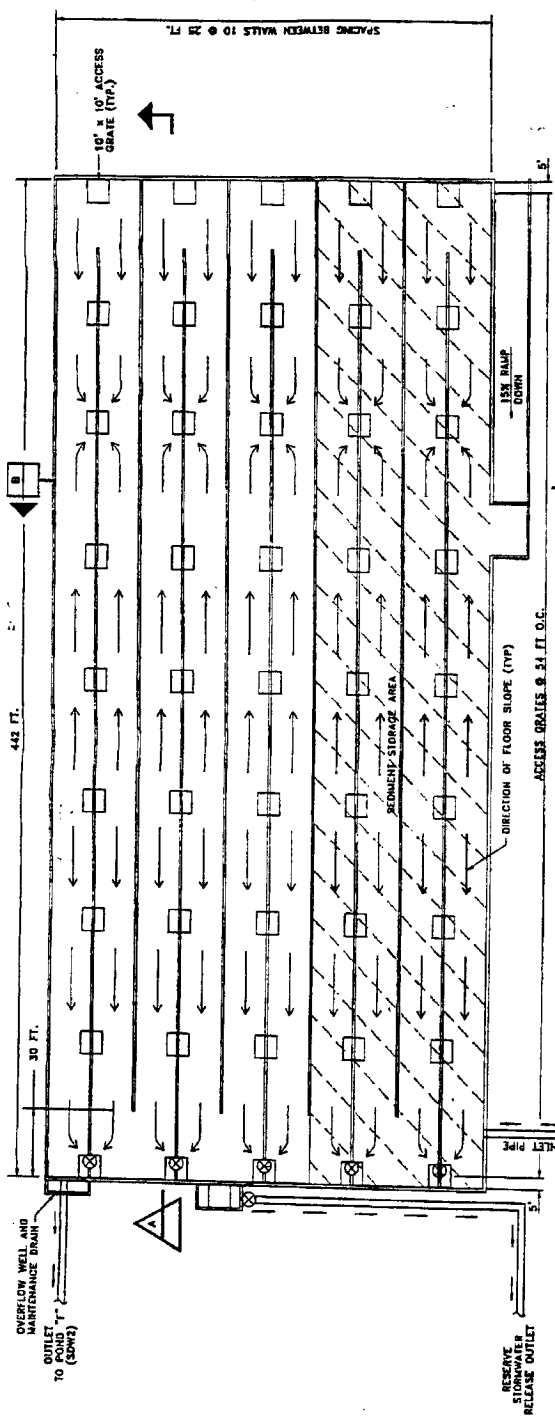

PLAN
SDW2 - WALKER CREEK
SCALE: NTS

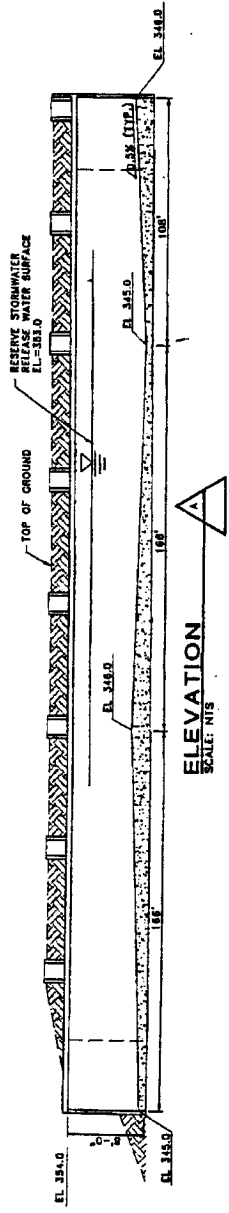

ELEVATION
SCALE: NTS

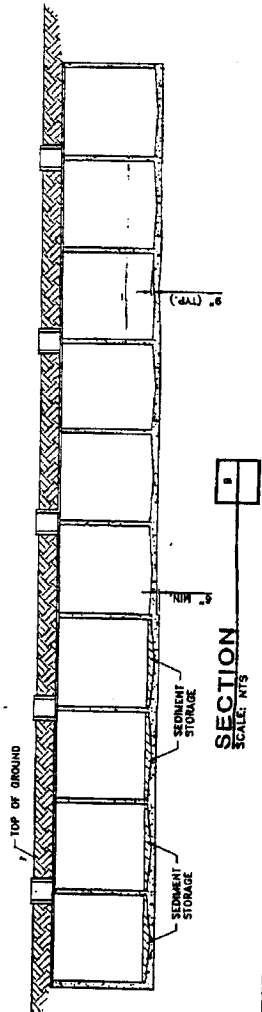

SECTION
SCALE: NTS

Port of Seattle
 SEATTLE INTERNATIONAL AIRPORT
 SEA-TAC INTERMEDIATE CONSTRUCTION
 PROJECT: THIRD RUNWAY - EMBANKMENT CONSTRUCTION
 SHEET NO. SDW2- WALKER CREEK
 EXHIBIT: SDW2-
 RESERVE STORMWATER RELEASE VAULT

AR 020059

Orifice Sizing Calculation

Seattle-Tacoma International Airport
 Low Flow Analysis
 Flow Impact Offset Facility Proposal

Given: Facility SDW2 SDS3
 Maximum Discharge (cfs) 0.11 0.08

Design		2"	1 3/4"
Orifice	Dia.	2	1.75
	Cd	0.62	0.62
	A	0.0218	0.0167
	H	1.00	1.00
	Q	0.11	0.08

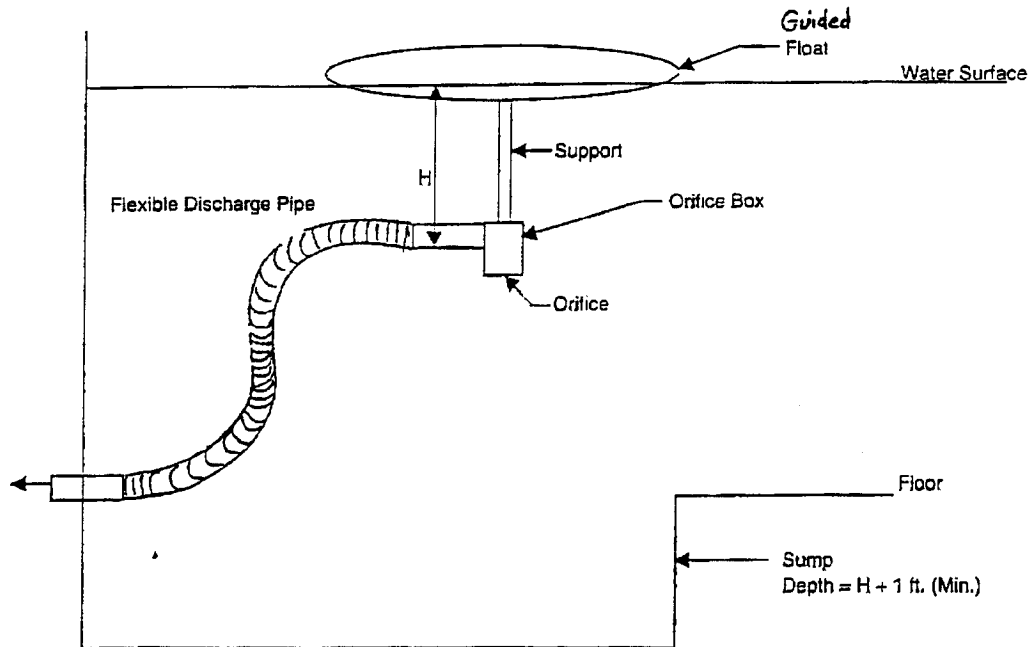

Appendix G

AR 020061

APPENDIX G

**PHYSICAL HABITAT SURVEY AND MONITORING PROTOCOL
FOR WADABLE STREAMS**

AR 020061.01



PHYSICAL HABITAT SURVEY AND MONITORING PROTOCOL FOR WADABLE STREAMS

RATIONALE

These protocols were designed based on the Tri-County Urban Stream Baseline Evaluation Methodology (UEBEM) (R2 Resources Consultants et al. 2000). The protocols were designed to provide year to year comparisons of several habitat attributes.

REACH SELECTION AND DELINEATION

A physical habitat survey will be conducted in 100 percent of Miller Creek in the buyout area. Additional surveys will be conducted in approximately 25 percent of the total length of each reach type (palustrine, floodplain, alluvial plain, large contained, moderate gradient mixed control, moderate gradient contained, and high gradient contained [Paustian et al. 1992]) within Des Moines, Walker, and the remainder of Miller Creek, depending on site access. All surveys will be conducted during the low-flow period of the year.

REACH UNIT LENGTH

To facilitate the development regulation appropriate to aquatic ecosystem conditions within the Port of Seattle (Port), a standard survey reach length of approximately 30 bankfull channel widths will be used. Bankfull width (BFW) measured at the beginning of each unit reach will be used to calculate the reach unit length. Lengths of less than 30 channel widths will only be measured if the reach type changes before a length of 30 channel widths. If there is a significant change in the stream system and/or channel characteristic (e.g., landform, floodplain width, stream gradient, channel form, adjacent land use, and major confluence), the reach will end at this point and a new reach assessment will begin. Reach assessments will begin at the downstream end of each reach.

FIELD EQUIPMENT

The following equipment will be used for the physical habitat monitoring:

- Field computer
- Stadia rod or wading stick (feet)
- Measuring tape
- Hip chain (feet)
- Flagging tape
- Thump tally
- Digital camera
- Abney level
- Off-channel habitat qualitative assessment forms (Attachment A)
- Culvert assessment data forms (Attachment B)
- Global positioning system (GPS) unit

FIELD COMPUTERS AND FILE MANAGEMENT

During the survey, data will be entered into a spreadsheet database contained on a Juniper Systems Allegro™ Field PC. Detailed operating instructions for both hardware and software are contained in the Allegro Field PC owner's manual, available to all field personnel. The following section describes the procedure each survey team should follow to ensure all data are stored in a useful and organized format.

Activate the Field PC by pressing the On/Off button (as long as the batteries remain charged, the field computers will revert to suspended mode when turned "off" or not used for a predetermined amount of time). Once activated, most of the subsequent functions are easily achieved using the touch screen. If for any reason during the survey the touch screen becomes inoperable, most necessary functions can be accessed using the keypad in much the same way as on a desktop PC.

At the beginning of each reach unit, open (double-click) the shortcut to **Str_Datasheet1.1.pt**, the main database file. The file contains six worksheets: one header sheet containing the information about the reach to be surveyed, five sheets for habitat parameter data entry, and a compilation sheet that organizes data from each of the previous sheets into a single spreadsheet (for data management purposes only). Before entering any data, use the *Save As* command in the *File* menu to save the file as the designated reach identification number. Make sure the file saves to the C drive, as this is the solid-state hard drive that stores data in the event power is lost. A backup copy of the blank spreadsheet is located in **C_MyDocs** in case the original is saved over.

Once the file is saved as the reach identification number, check to make sure the caps lock is engaged and begin filling all known reach information into the spaces provided in the header sheet. Begin surveying the stream, switching back and forth between habitat parameter sheets by tapping on the tab at the bottom of the screen and filling in appropriate information. Save the file periodically to minimize potential loss of data in the event of a computer lockup. At no time should data be entered into the compilation sheet (while the sheet is protected, some data entries are still possible). If data are entered inadvertently into the compilation spreadsheet, use the *Undo* function under the *Edit* pull-down menu to remove entries (deleting the entry may also delete equations built into the sheet). At the end of the reach, fill in all remaining blanks in the header sheet and perform a final save before closing the file.

Completed reach files should be transferred to an office computer after each day of survey and checked for invalid or missing data. Any anomalies should be recorded and communicated to the data manager.

GENERAL PROCEDURE

Comment Field

There may be times when this protocol does not fully capture a situation encountered during a survey. Comment fields are included as part of each spreadsheet in the database and are intended as a means to document instances when a measurement or classification of a habitat parameter is not completely clear. When these situations occur, surveyors are encouraged to

make comments based on their best professional judgment. Record a brief explanation of the decision in the comment field associated with the parameter in question.

Station

At the start of each reach, tie off and zero the hip chain. Record a station (in yards) for each piece of information gathered in the reach. The station designation provides an organizational record for data entry into an extensive field computer database. While the hip-chain station reading is fairly arbitrary on a subbasin scale, it allows the physical habitat information recorded to be analyzed, if need be, on a site-specific level. The station designation also provides the opportunity for quality control surveys.

Protocol for Dry Channels

Channels that are dry at the time of the survey will be surveyed for BFW and wood and bank instability. If dry channels have standing water in pools and these pools meet the survey criteria, they will also be recorded.

HEADER INFORMATION

Purpose: Header information, like all data collected with this protocol, is linked to a database tab within the data sheet. These database tabs facilitate downloading data into Microsoft Access. From there, the data can be organized, checked for quality, and imported into various analysis packages such as Excel and Analytica.

Procedure: The header information is arranged to organize the reach data. At the start of each reach, obtain latitude and longitude from the GPS unit and record. Load additional information into the appropriate areas. An information box is available under the comment space that will automatically calculate, after the initial BFW is measured, the minimum pool depth and size, large woody debris (LWD) length and width, and the general locations of additional BFW measurements (Figure G-1).

HABITAT PARAMETERS

Bankfull Width

Purpose: BFW is the primary measure of channel size and is used to determine the minimum size of functioning pools and woody debris along the reach (explained below), as well as the reach unit length.

Definition: BFW is the width of a stream channel at the point where over-bank flow begins during a flood event. In entrenched channels with disconnected or undeveloped floodplains, bankfull indicators may include: the top of deposited bedload (gravel bars), stain lines, the lower limit of perennial vegetation, moss or lichen, a change in slope or particle size on the streambank, and undercut banks (USFS 1999).

Figure G-1. Example Data Entry for Reach Unit Header Sheet

Minimum Functional Pool Requirements				Minimum Key LVD Requirements			
Minimum Residual Pool Depth (ft)	Minimum Pool Size (ft ²)	Minimum Length (ft)	Minimum Diameter (ft)				
0.33	0.4	26	13				

Procedure: For each 166-yard (roughly 500 ft long) reach, three BFW measurements will be made. Measure BFW at the crest of the first riffle, at the crest of the riffles nearest a distance of 83 yards upstream, and at the crest of the last riffle nearest a distance of 166 yards upstream. Straight, low-gradient riffles with uniform banks are best for identifying bankfull stage and therefore BFW. Locate bankfull stage by using any of the above indicators on at least one of the streambanks. Measure the width of the channel at the indicated point and record it in the handheld computer database (Figure G-2).

BANK CONDITIONS

Purpose: To assess channel stability and response to watershed conditions. This protocol will follow the definitions used by Bauer and Burton (1993):

Definitions:

- **Bank Stability:** Defined by the American Fisheries Society (Armantrout 1998) as the resistance of a bank to erosion.
- **Bank Instability:** Banks are considered stable unless they show indications of any of the following features at or above bankfull (this list is for reference only, surveyors are not expected to record the instability type):
 - **Breakdown:** obvious blocks of bank broken away and lying adjacent to the bank breakage.

Figure G-2. Example Data Entry for Start, Midpoint, and End BFW Measurements

Station 0-Hip-Chain Read (ft)	Rifle Measure		Comments
	BFW (ft)	Rifle Wetted Width (ft)	
0	3.2	2.0	
80	3.6	1.8	
168	3.4	2.3	

1st BFW Meas =	0	Yd
2nd BFW Meas =	83	Yd
3rd BFW Meas =	166	Yd

- **Slumping or False Bank:** bank has obviously slipped down, cracks may or may not be obvious, but the slump feature is obvious.
- **Fracture:** a crack is visibly obvious on the bank indicating that the block of bank is about to slump or move into the stream.
- **Vertical & Eroding:** The bank is mostly uncovered as defined below *and* the bank angle is steeper than 80° from the horizontal.
 - Perennial vegetation ground cover < 50 percent.
 - Roots of vegetation cover < 50 percent of the bank.
 - Rocks of cobble size or larger protect <50 percent of the bank surfaces.
 - Logs of ≥10-cm diameter protect < 50 percent of the bank surfaces.
- **Bank Hydro-Modification:** For hydro-modified banks, record the type of modification and the material composition of the toe of the feature (at and below the bankfull elevation). Seven categories of hydro-modification are listed below:
 - **DI: Dike/Levee/Berm**
 - **RE: Revetment**
 - **BU: Bulkhead**
 - **BR: Bridge Footing**
 - **BE: Beaver Dam**

- DA: Dam
- CU: Culvert

To capture the extent of beaver dams in the system, we have included them as a category distinct from human-created dams. All dams (beaver or human) that are connected bank-to-bank and impound water, as well as any abandoned dams that are encountered, will be noted.

The five categories of material composition are listed below:

- RI: Riprap – bank material > 10 inches (256 cm) in diameter.
- RU: Rubble – bank material < 10 inches (256 cm) in diameter will be considered rubble.
- ST: Structural – other material such as wood (other than LWD), concrete, and gabion.
- EA: Earth – includes artificially placed soil as well as other “natural” toe materials.
- BE: Beaver Dam – material that was placed by beavers (used only for beaver dam hydro-modification).

Procedure: Stream bank instability and hydro-modification will be continuously measured along both banks. When a portion of bank that meets the above criteria is encountered, identify whether it is on the right or left bank (facing downstream) and record the hip-chain reading in the field computer database. Continue with the survey collecting data on any and all other required stream features. When the end point of the bank feature is reached, record the hip-chain reading in the database. The length of the feature will be calculated automatically. In instances when the feature is small and more easily measured with a stadia rod or tape, do so and enter the length in the end point column. If the channel is braided, then measure bank features along the banks furthest to the right and left only. For beaver dams that extend from bank-to-bank, enter a “B” in the bank column, enter “Beaver Dam” in the hydro-modification column, measure the downstream height and width of the dam, and place those measurements in the comments field. Finally, measure the length of the hydrologic impoundment (Figure G-3).

WOOD STRUCTURE FREQUENCY (ADAPTED FROM WFPB 1997)

Purpose: To measure the type and amount of wood providing habitat complexity and hydraulic roughness.

Definitions: Wood structures are classified into three categories (woody debris, stumps, and jams) using the following definitions:

- **Key Large Woody Debris (LWD)** – defined as downed wood that intercepts bankfull flow in a substantial fashion and is large enough to influence the formation of habitats (USFS 1999). To be counted as key LWD, a piece of wood must meet the minimum criteria listed in Table G-1, which are based on the average BFW for the reach surveyed. To qualify, a piece of wood must have a minimum length of greater than 26 ft (for BFW of 0 to 16.4 ft). Additionally, the diameter of the wood must be greater than 1.3 ft (again for BFW of 0 to 16.4 ft). Wood that spans the bankfull channel and touches just above bankfull on both sides is counted.

Figure G-3. Example Data Entry for Stream Bank Condition

Station	R, L, B Bank	Stream Bank Instability (SI ID)		Hydromodification			HydroModif. (D, RE, BU, BR, BE, DA, CU)	Armor @ Tee (R, NU, ST, EA, BA)	Comments
		Start Pt.	End Pt.	Calc. Inst.	Start Pt.	End Pt.			
188.8	L	188.9	199						
188.8	R	188.6	184.5						
195.8	S				186.8	205.9	BEaver Dam	Beaver Dam	3'W30'W50'LONG
207.5	R				207.5	300.5	Revetment	RipRap	

Table G-1. Minimum size to qualify LWD as a key piece (WFPB 1997).

Bankfull Width		Diameter		Length	
Meters	Feet	Meters	Feet	Meters	Feet
0-5	0-15	0.40	1.3	8	26
6-10	15-30	0.55	1.8	10	33
11-15	30-45	0.65	2.1	18	60
16-20	45-60	0.70	2.3	24	79

- **Stump** – A rootwad with a diameter greater than or equal to 3 ft and a length and/or bole diameter less than the minimum LWD criteria. The rootwad or attached bole must significantly intercept bankfull flow.
- **Small Wood** – If wood is more than 6 ft long and greater than 4 inches in diameter at the narrowest end, then the wood is tallied with a hand counter and recorded on the header page at the end of the reach.

In addition to LWD dimensions, wood debris is further characterized by collecting data on rootwad presence, wood type, decay class, and association with a jam. These attributes are defined as:

- **Rootwad Presence** – for a rootwad to be counted on a piece of woody debris, the rootwad diameter must be at least 3 ft.
- **Wood Type** – Deciduous (D), evergreen/conifer (C), or unknown (U). A decay class of 5 “old” (see below) automatically enters a U into the proper field.
- **Decay Class** – characterizes each piece based on the condition of the wood from natural decay. Table G-2 lists the criteria for three decay classes: “recent” (1), “intermediate” (3), and “old” (5).

Table G-2. Decay class criteria (Collins et al. 2001; Schuett-Hames et al. 1994).

Decay Class	Bark	Twigs	Texture	Shape	Wood Color
1	Intact	Varies	Intact	Round	Original Color
3	Trace	Absent	Smooth	Round	Darkening
5	Absent	Absent	Abrasion	Round/Oval	Dark

- **Jam** – Three or more touching pieces of woody debris and/or stumps (defined above) together producing a single structure significantly intercepting bankfull flow.

Procedure: Determine minimum length and diameter of key large woody debris based on bankfull width at the starting point of the reach. Measure the diameter of the key woody debris wood at the minimum required length and record. Also record the general station of all wood debris (including stumps) using the hip-chain, wood type, decay class, rootwad presence or absence, and jam association (jam or single piece). Decay class and wood type information are not required for stumps. Tally and record all small wood that meets the minimum size criteria as defined above (Figure G-4).

Comments for wood structure may include but are not limited to general descriptions about stream conditions caused by wood or lack of it and potential for future wood recruitment. Notations concerning small wood that does not meet minimum criteria can also be entered.

RIPARIAN AREA

Purpose: Riparian vegetation influences the productivity and habitat characteristics of a stream reach. This protocol characterizes riparian vegetation following the Washington Department of Natural Resources (WDNR) standard methodology for assessing riparian vegetation along streams using aerial photographs combined with field verification (WFPB 1997).

Table G-3. Riparian vegetation types for King County stream surveys.

Type	Code	Description
Conifer dominated	C	Forested, more than 70% of trees are conifer
Hardwood dominated	H	Forested, more than 70% of the trees are hardwood
Mixed	M	Forested, no dominance greater than 70%
Shrub	S	Dominated by woody stemmed vegetation that does not reach > 40 ft at maturity, e.g., willows (<i>Salix</i>), dogwood (<i>Cornus</i>), and salmonberry (<i>Rubus</i>).
Grass or cleared	G	Pasture, row crops, maintained rights-of-way, orchards, parkland, landscaped areas, vacant fields, marshes, and wetlands not in open water.
Urban	U	Greater than 70% of RCU is paved or built-up. Includes roads, levees, railroads, and bridges.

Table G-4. Size classifications for riparian trees.

Type	Code	Description
Small	S	Dominant trees in the RCU: DBH between 3" and 12"
Medium	M	Dominant trees in the RCU: DBH between 12" and 20"
Large	L	Dominant trees in the RCU: DBH greater than 20"
Not applicable	X	Value applied to the shrub, grass, and urban classes

Table G-5. Density classes for riparian trees.

Type	Code	Description
Dense	D	More than 1/3 of the RCU is covered by trees
Sparse	S	Less than 1/3 of the RCU is covered by trees
Not applicable	X	Value applied to the shrub, grass, and urban classes

POOLS, RIFFLES, AND SUBSTRATE

Purpose: To characterize the stream longitudinal profile as a measurement of fish habitat, and to quantify substrate conditions in potential spawning locations as an assessment of the risk to eggs and juveniles from entombment, oxygen depletion, gill abrasion, and foraging difficulty.

Definitions:

- **Pool** – a section of stream channel where water is impounded within a closed topographical depression (Abbe and Montgomery 1996).
- **Riffle** – defined by the American Fisheries Society (Armantrout 1998) as: "...characterized by small hydrologic jumps of rough bed material, causing small riffles, waves, and eddies..."

- **Substrate (bed load)** – defined by the American Fisheries Society (Armantrout 1998) as a general term that refers to the sediment moved by a stream at the bottom.

Procedure: Data are loaded in the Pools_Fines tab of the computer (Figure G-5). Pool parameters will be recorded for pools meeting the BFW, residual depth, and surface area criteria described in Table G-6.

Figure G-5. Example Field Computer Data Entry for Pools, Riffles, and Substrate

The screenshot shows an Excel spreadsheet titled "Microsoft Excel - IssaquahStr_Ds1.1.xls". The spreadsheet is set to Arial font, size 16, with a zoom level of 125%. The active cell is B9. The spreadsheet contains a table with the following columns: Station (with sub-columns for (M), (C), (R), (L)), Riffle Hip-chain (with sub-columns for Start, End, (TW)), Dominant Substrate (with sub-columns for Size Class 1-7), Sub-Dom. Substrate (with sub-columns for Size Class 1-7), Embedd-ness (with sub-columns for Low, Med, High), Pool Hip-chain (with sub-columns for Start, End), Pool Habitat (with sub-columns for Hard, Soft, Matted, Forest, Wooded, Fresh, Salt, Brack, Bore), and Comments. The data rows show values for these parameters across multiple stations, with some cells containing "N/A".

Table G-6. Minimum pool size requirements.

Bank Full Width (ft)	Area (ft ²)	Residual Pool Depth (ft)
0 – 8	5.4 (0.5 m ²)	0.33 (0.10 m)
8 – 16	10.8 (1.0 m ²)	0.66 (0.20 m)
16 – 33	21.5 (2.0 m ²)	0.82 (0.25 m)
33 – 49	32.3 (3.0 m ²)	0.98 (0.30 m)
49 – 66	43.1 (4.0 m ²)	1.15 (0.35 m)
>66	0.2 x BFW	0.0968 x BFW ^{0.4608}

Based on: Schuett-Hames et al. 1994.

When a pool is encountered, the following will be done:

1. Measure the maximum pool depth and tailout depth using a stadia or wading rod.
2. Calculate the residual pool depth (maximum depth minus pool tailout) manually with a calculator or automatically by entering the depth values into the appropriate database fields.
3. Maximum pool depths of more than 6.0 ft may be entered into the spreadsheet as 6.0 with "over 6 ft" entered in the comment field.
4. If the calculated residual depth value falls within the criteria in Table G-6, measure the mean wetted width and length of the pool, and the mean *functional* width and length. The functional area is the area of the pool most likely to be used by adult salmonids for holding, and is defined by a minimum depth from Table G-6 or the pool tailout depth, whichever is greater. This definition captures the deeper areas of the pool and excludes the shallow margins as the pool tapers toward the banks.
5. If the functional area meets the area requirements in Table G-6, the pool is of acceptable size. If it does not, remove the entered measurements from the record and continue surveying.
6. When two or more pools occur in sequence, they should be split and measured separately whenever there is a clear division (tailout) between them.

Calculate the *functional* pool surface area (length x width) manually with a calculator or automatically by entering the functional pool length and width values into the field computer database. If the calculated area falls within the criteria for the BFW (see Table G-6), enter all of the remaining required information for the pool unit into the field computer database.

When a riffle is encountered, the survey team will do the following and enter data in the *Pools_Fines* tab of the computer (see Figure G-5):

1. Enter "R" in the "Habitat Unit" column.
2. If "R" is entered, the "Riffle Hip-chain" start measurement will automatically load.
3. In the "Riffle End" column, enter the hip-chain location of the end of the riffle.
4. In the "Spawning Potential (Y/N)" column, enter the appropriate response based on best professional judgement.

If a spawning riffle is present, an assessment of substrate condition will be performed. The surface substrate composition provides an indication of the habitat quality for salmon spawning. A visual estimation can provide identification of potential spawning areas. Care must be taken in identifying the dominant/subdominant substrate, particularly in the correct classification of cobble and boulders. This will be aided by the use of a small ruler while in the field.

If there is spawning potential, enter the dominant and subdominant substrate present in the riffle/pool tailout. There are seven numerical choices, as follows (Bovee 1982):

- 1 = Bedrock
- 2 = Silt/organic (<2mm)
- 3 = Sand (2 - 4mm)
- 4 = Small gravel (4 - 25mm)
- 5 = Large gravel (25 - 74 mm)
- 6 = Cobble (74 - 300 mm)
- 7 = Boulder (>300mm)

Embeddedness (the percent that interstitial spaces are filled with small grain particles) will also be measured in all riffles that potentially support spawning. Embeddedness is also used as a measure of fine sediment concentrations in the substrate (May et al. 1997). Percent embeddedness is measured based on visual estimation. Enter one of the following classes into the computer for each potential spawning riffle.

L = Low: Gravel, pebble, cobble, and boulder particles have < 20 percent of their surface covered by fine (sand, silt, clay) particles.

M = Medium: Gravel, pebble, cobble, and boulder particles have 20 to 40 percent of their surface covered by fine (sand, silt, clay) particles.

H = High: Gravel, pebble, cobble, and boulder particles have > 40 percent of their surface covered by fine (sand, silt, clay) particles.

SECONDARY CHANNEL HABITAT

Purpose: To quantify habitat in secondary channels and identify significant off-channel features.

Definition: Secondary channels are defined as channels that are separated from the main channel by a stable island and contain the smaller portion of the total flow. A stable island in a forested stream is defined by the United States Forest Service (USFS 1999) as supporting woody vegetation (excluding willows that do not meet the tree definition), which is estimated to be at least 5 years old (and covers at least 50 percent of the island surface). Off-channel habitats include marshes, ponds, and oxbow lakes that are outside the bankfull channel.

Procedure: Identify whether or not a potential secondary channel feature is separated from the main channel by a stable island. If the feature is not separated by a stable island, then lump it in with the main channel measurements. If the feature is located outside the bankfull channel, then describe the off-channel feature in the comments.

Side channels will be evaluated using the qualitative habitat assessment sheet (Attachment A). No measurements will be taken, but the location (reach number, hip-chain distance, bank location - RB or LB) will be recorded on the sheet, with a brief description of any significant features, such as amount of flow in channel. Determine whether the secondary channel within the bankfull channel is dry, connected at one end (channel type SC1), or connected at both ends (channel type SC2) at the time of the survey, and record the corresponding code on the survey form. No data entry is required for secondary channel measurements.

FISH PASSAGE BARRIERS

Purpose: During field investigations, the teams may encounter potential fish blockages. In these areas, the team will perform a rapid passage assessment based on the Washington Department of Fish and Wildlife's (WDFW) Level A approach for culverts and non-culvert blockages (e.g. dams, bedrock-dominated shallow glides, cascades, etc) (WDFW 2000). Assessing potential fish barriers will help provide a list of potential capital improvement projects (CIPs) and restoration projects.

Definition:

- **Fish Barrier** – defined by the American Fisheries Society (Armantrout 1998) as: any physical, physiographic, chemical, or biological obstacle to migration or dispersal of aquatic organisms. For this assessment, only physical barriers will be examined.

Procedure: During the survey, data will be entered onto hard copy datasheets (Attachment B). The surveyors will use the WDFW Level A assessment to establish a fish passage database and provide repair recommendations. The information will be loaded into an electronic database that can be used for later Level B assessments. Level B assessments require instrument survey and hydrologic analysis. The assessment team will not perform Level B assessment during this project.

When a culvert is encountered, the assessment team will perform a WDFW Level A culvert assessment. The Level A assessment is relatively simple and is explained in the dichotomous key below. The key will determine if the culvert is *a barrier*, *not a barrier*, or *unknown*. If the determination leads to an *unknown* status, the assessment team will use their professional judgment to determine the extent of a potential blockage and will recommend that future Level B assessments occur on the culvert.

Prior to conducting this assessment, each team should download and print the WDFW manual from the WDFW website (www.wa.gov/wdfw/hab/engineer/fishbarr.htm [PDF format]). Several portions of this protocol are taken directly from the WDFW approach, and their manual provides additional details and clarification.

Level A Barrier Analysis (WDFW 2000)

- A. Is there natural streambed material throughout the culvert?
 - a. If yes, is the culvert width (span) at least 75 percent of the average streambed toe width at the second riffle downstream of the culvert (representative riffle)?
 - i. If yes, the culvert is *not a barrier* and additional measurements are not required.
 - ii. In no, go to B.
 - b. If no, is there an outfall > 0.24 m?
 - i. If yes, the culvert is a barrier and additional measurements are not required.
 - ii. If no, is the culvert slope > 1 percent?
 1. If yes, the culvert is *a barrier* and additional measurements are not required.
 2. In no, go to B.

- B. *Is there a grade break in the culvert?*
 - a. If yes, then the barrier status is *unknown* and a Level B analysis is not possible.
 - b. If no, then go to C.
- C. *Is the culvert tidally influenced or is there a large pond or wetland downstream of the culvert making it difficult or impossible to obtain the downstream control cross-section information?*
 - a. If yes, then the barrier status is *unknown* and a Level B analysis is not possible.
 - b. If no, go to D.
- D. Barrier status is *unknown* and a future Level B analysis will be required.

Grade breaks occur in cases where culverts have been extended and the new section is installed at a different elevation or slope than the old culvert. This can also occur when a section of culvert settles or a joint fails. In cases where the slope of any portion of the culvert exceeds 1 percent or the drop inside the culvert exceeds 0.24 m, then it can be categorized as a barrier. If the slope does not exceed 1 percent or the drop does not exceed 0.24 m, or if these parameters cannot be measured, then the barrier status of the culvert is unknown and a higher level of analysis is required.

DATA ENTRY FOR FIELD CULVERT DATASHEET

The field datasheet requires the team to collect a suite of location and structural information that will later be used for a culvert database and for future analysis. The header information of the datasheet provides location information. It is important that the culvert is located by street crossing or by GPS. Once the location is acquired, all of the additional information required for the WDFW database can be extracted from GIS databases.

Culvert structural information is self-explanatory from the datasheet. This information is important for the WDFW database and for future analysis.

Measurements Required in the Field

1. Measure the length of the culvert in meters.
2. Assess if natural streambed is present *throughout* the culvert.
3. Measure the horizontal span of the culvert at the downstream side.
4. Measure the average streambed toe width at the second riffle downstream of the culvert. The streambed toe is defined by WDFW as the bottom of each bank, and in some cases can be below the wetted surface elevation.
5. Measure the outfall drop from the top of the water in the culvert to the top of the water downstream of the culvert to the nearest 0.01 m.

6. Measure the slope of the culvert from the culvert upstream invert elevation to the culvert downstream invert elevation in percentage $((USIE-DSIE)/Length*100 = \text{Slope})$. This can be done with an Abney level, or a bubble level and two wading/stadia rods. The WDFW manual states that clinometers are not acceptable for slope measurements.

Photographs

All culverts that receive an *unknown* or *barrier* status should have a photograph. These photographs will help the teams later determine the significance of each blockage and provide an eventual CIP needs list. Keep track of photograph and roll numbers on the datasheet.

FISHWAY AND DAM BLOCKAGES

Below is a brief description of fishway and dam blockages summarized from the WDFW manual. Again, the field teams should familiarize themselves with the WDFW manual. The datasheets will also be useful for describing non-culvert barriers found in the field. These datasheets, like the qualitative datasheets, will help the field teams develop and document the rationale for their professional judgment and determination of CIP lists.

- **Fishways** – A fishway is any human-made structure that facilitates the passage of fish through or over a barrier. As fishways frequently fail or are poorly designed, WDFW recommends that fishways be assessed as dams.
- **Dams** – A dam is any human-made structure that results in an abrupt change in water surface elevation. WDFW states that a water surface difference greater than 0.24 m is a block to chum and greater than 0.30 m is a block to all other fish. Dams with standpipes are always barriers.

Photographs

All dams or fishways that receive an *unknown* or *barrier* status should be photographed. These photographs will help the teams later determine the significance of each blockage. Record photograph and roll numbers on the datasheet.

AVAILABLE RESOURCES

The WDFW web site mentioned above provides useful information. Other resources include:

- A Catalog of Washington Streams and Salmon Utilization (Williams et. al. 1975)
- Tri-County salmon information web site (<http://www.salmoninfo.org/>)
- Forest Service Fish Xing web site (<http://www.stream.fs.fed.us/fishxing/index.html>)

REFERENCES

Abbe, T.B. and D.R. Montgomery. 1996. Large woody debris jams, channel hydraulics and habitat formation in large rivers. Regulated Rivers: Research & Management, Vol. 12, 201-221.

- Armantrout, N.B. (compiler). 1998. Glossary of aquatic habitat inventory terminology. American Fisheries Society, Bethesda, Maryland.
- Bauer, S.B. and T.A. Burton. 1993. Monitoring protocols to evaluate water quality effects of grazing management on western rangeland streams. U.S. Environmental Protection Agency Region 10, Seattle, Washington.
- Bovee, K.D. 1982. A guide to stream habitat analysis using the Instream Incremental Methodology, Instream Flow Information Paper 12, FWS/OBS-28/26, Co-operative Instream Flow Group, US Fish and Wildlife Service, Office of Biological Service.
- Collins, B.D., D.R. Montgomery, and A.D. Haas. 2001. Historic changes in the distribution and functions of large woody debris in Puget Lowland rivers, submitted to Canadian Journal of Fisheries and Aquatic Science.
- Lindsey, A.A., J.D. Barton Jr., and S.R. Miles. 1958. Field efficiencies of forest sampling methods. *Ecology* 39(3):428-444.
- May, C.W., E.B. Welch, R.R. Horner, J.R. Karr, and B.W. Mar. 1997. Quality indices for urbanization effects in Puget Lowland streams. Report prepared for Washington Department of Ecology. Water Resources Series Technical Report No 154.
- Paustian, S.J. (editor) and 13 others. 1992. A channel type users guide for the Tongass National Forest, Southeast Alaska. USDA Forest Service, Alaska Region, R10 Technical Paper 26. 179 pp.
- Platts, W.S., W.F. Megahan, and G.W. Minshall. 1983. Methods for evaluating stream, riparian, and biotic conditions. USDA Forest Service General Technical Report INT-GTR-188.
- R2 Resources Consultants, CH2M Hill, and Shapiro and Associates. 2000. Tri-County urban issues ESA study: Guidance document. February 2000. Prepared for the Tri-County Urban Issues Advisory Committee, Bellevue, Washington.
- Schuett-Hames, D., A. Pleas, L. Bullchild, and S. Hall (eds.). 1994. Ambient monitoring program manual. Timber-Fish-Wildlife, TFW-AM9-94-001. Northwest Indian Fisheries Commission, Olympia, Washington.
- USFS (United States Forest Service). 1999. Stream inventory handbook: Level I & II. USDA, Region 6, Version 9.9.
- Wang, L., T.D. Simonson, and J. Lyons. 1996. Accuracy and precision of selected stream habitat estimates. *North American Journal of Fisheries Management* 16:340-347.
- WDFW (Washington Department of Fish and Wildlife). 2000. Fish passage barrier and surface water diversion screening assessment and prioritization manual. WDFW Habitat Program Environmental Restoration Division: Salmonid Screening, Habitat Enhancement, and Restoration (SSHEAR) Section. Olympia, Washington.

WFPB (Washington Forest Practices Board). 1997. Standard Methodology for Conducting Watershed Analysis under Chapter 222-22 WAC. Version 4.0, November 1997. Washington Department of Natural Resources, Olympia, Washington.

Williams, R.W., R.M. Laramie, and J.J. Ames. 1975. A catalog of Washington Streams and Salmon Utilization. Vol. 1. - Puget Sound. Wash. Dept. Fish, Olympia, Washington.

ATTACHMENT A
QUALITATIVE DATASHEET

AR 020080

Port of Seattle Qualitative Assessment Field Form

Date:	Team Name:
Sub Basin:	Stream Name:
Rosgen Class:	Reach ID Number:
Site number	Lat.: Long:
Sample Location:	Above Culvert (y/n)?
Photo Roll:	Photo Numbers:

Limiting Factors	Good (1)	Fair (2)	Poor (3)	Yes (Y)	No (N)
Habitat Trend:					
Subjective Habitat Rating					
Improving Habitat					
Deteriorating Habitat					
Are the Following Limiting Factors for Habitat?					
Unstable banks					
Hydro-modifications					
Lack of Shade					
Eutrophication					
Flashy Hydrology					
Turbidity					
Lack of Undercut banks					
Habitat Ratings					
Spawning Areas					
Pool Abundance					
Pool Quality					
Riffle abundance					
Aquatic Invertebrate Quality					
Bank Cover (e.g.Brush and Roots)					
Riparian Cover					
Large Woody Debris					
Embeddedness					
Dominant/Subdominant Substrate (in mm) Check Box	Silt/Clay/ Organic (<0.059)	Sand (0.06-1)	Small Gravel (.25-1.25)	Large Gravel (1.25 -2.5)	Cobble/ Boulder (>2.5)
Dominant					
Subdominant					
Approximate % Grade:	Comments:				

ATTACHMENT B
FISH PASSAGE/CULVERT ASSESSMENT DATASHEET

Port of Seattle Fish Passage/Culvert Assessment Field Form

Date:	Team Name:
Sub Basin:	Stream Name:
Rosgen Class:	Reach ID Number:
Photo Roll:	Photo Numbers:

Feature Type					
Culvert	Fishway	Dam	Gravity Diversion	Pump Diversion	Other (describe)

Feature Location: _____

Lat: _____ Long: _____

Culvert Previously Assessed (Y/N)? _____ If yes then stop, if no continue.

Culvert Shape					
Round (RND)	Box (BOX)	Bottomless Arch (ARCH)	Squash (SQSH)	Ellipse (ELL)	Other (OTH) describe:

Culvert Material						
Precast concrete (PCC)	Cast in Place Concrete (CPC)	Corrugated Steel (CST)	Smooth Steel (SST)	Corrugated Aluminum (CAL)	Structural Plate Steel (SPS)	Structural Plate Aluminum (SPA)
Plastic (PVC)	Timber (TMB)	Masonry (MRY)	Other (OTH) describe:			

Culvert Assessment		
1. Culvert length in Meters _____		
2. Streambed material throughout the length of Culvert (y/n)? _____		
If 2 is Yes, measure the following:		
A. Culvert span in meters - _____		
B. Streambed toe width of second riffle down stream from culvert in meters - _____		
If riffle not available, culvert status is <i>unknown</i> .		
C. $A/B * 100 =$ _____ %		
If C is $\geq 75\%$ then culvert status is <i>not a barrier</i> , otherwise culvert is <i>a barrier</i> .		
Culvert Status	<i>Barrier</i>	<i>Not a Barrier</i>
		<i>Unknown</i>
If 2 is No, measure the following:		
A. Outfall Drop in meters (water surface to water surface) - _____		
If A is > 0.24 meters culvert is <i>a barrier</i> , if not go to B.		
B. Culvert slope measured from invert to invert in percentage - _____ %		
If B is $\geq 1\%$ culvert is <i>a barrier</i> , if not culvert status is <i>unknown</i> .		
Culvert Status	<i>Barrier</i>	<i>Not a Barrier</i>
		<i>Unknown</i>

Professional opinion of culverts with *unknown* status, general repair recommendations, general comments:

Appendix H

AR 020084

APPENDIX H
LOW STREAMFLOW FISH BEHAVIOR MEMORANDUM

MEMORANDUM

to: Paul Fendt July 20, 2001
from: Don Weitkamp 556 2912 001 1 28
re: Low Stream Flow Fish Behavior and Stream Characteristics

The following are some thoughts on the issues raised in the e-mail message from Kelly Whiting to Ann Kenny of July 2, 2001 which we discussed at our meeting with the agencies.

1. Migrations of juvenile and adult salmonids appear to be stimulated/regulated by a variety of biological and physical factors of which flow is one. Young fish generally require growth to a certain size range before migration will occur. The physiological processes (smoltification) that ready them for migration also depend of a sequence of events that appears to be triggered by a combination of temperature, photoperiod, and phase of the moon that stimulate hormonal mediated physiological changes. Once these fish are prepared to migrate a substantial change in flow will often trigger the initiation of migration. However, flow increases alone are not likely to initiate a process that depends on many factors.

Likewise the migrations of adult salmonids are commonly the result of a variety of factors. Adults commonly do not approach streams or prepare to move into headwaters until specific times apparently regulated by photoperiod, temperature, potentially food supply, etc. When ready to migrate the adults are commonly stimulated by freshet conditions that involve both a flow increase and runoff from riparian areas. The chemical cues in the runoff appear to play some role in triggering the migrations. The relationship to flow is far from certain. Sometimes minor increases in flow will stimulate migrations, sometimes minor increases are ignored, and sometimes migrations occur in the absence of flow increases. A minor flow supplementation during normal low flow periods is not likely to provide a trigger for biological processes that would not normally occur during that time period.

2. Severe drought conditions are generally a habitat-limiting factor that can severely limit the carry capacity of a stream. In most Puget Sound lowland streams the low flow conditions of late July to mid-September determine the minimum habitat available to support the resident fish populations including juvenile salmon and trout. Prolonged low flows of several weeks to months during this period are commonly the factor that establishes the carrying capacity of a stream.

Protection or restoration of stream flows during the late July through September period will maintain the habitat that sustains and controls fish populations remaining within the stream through out the year. Stream flow supplementation during this period can have a substantial

influence on the abundance of resident and anadromous salmonids. Providing flow outside this late summer low flow period is unlikely to provide an increase in the fish population that can be sustained within the stream. Additional habitat provided by flow increases preceding the limiting low flow period is unlikely to provide an increase in the fish population following the low flow period. The potential effects of providing additional habitat outside the limiting flow period would likely be negated by the subsequent low flows. Maintaining existing flow conditions during the common low flow period will ensure that habitat does not become more of a limiting factor than it is under existing conditions.

3. Water quality can be a critical factor in determining salmonid habitat. However, sudden changes of a moderate degree are naturally common in small streams. Freshet conditions (storm events) can naturally change temperature and chemical parameters within hours, depending on the nature of the storm event, the drainage basin, stream characteristics and ambient conditions. Generally decreasing temperatures have little immediate effect on salmonids other than reduced activity for a brief period. Decreasing temperatures rapidly within the range of a few degrees can be a benefit if temperatures are near the upper end of the range of acceptable temperatures or greater. Decreases in DO appear to have little effect on behavior when they remain within a range acceptable for survival and growth. The relatively small amount of water provided during low flow mitigation together with the proposed oxygenation techniques is likely to maintain adequate DO conditions.



APPENDIX I
DETERMINATION OF LOW FLOW QUANTITY IMPACTS
AND MITIGATION

AR 020089



MILLER CREEK

7-DAY LOW FLOW OCCURRENCES IN MILLER CREEK (1994)

BAR GRAPH LOW FLOW OCCURRENCES IN MILLER CREEK (1994)

7-DAY LOW FLOW OCCURRENCES IN MILLER CREEK (1991-1994)

CALCULATION OF 50% RETURN FREQUENCY FOR MILLER CREEK

COMPARISON OF 7-DAY LOW FLOW BY YEAR

AR 020090

7-DAY LOW FLOW OCCURRENCES IN MILLER CREEK (1994)

AR 020091

Start of 7-Day Low Flows with Average Flow Rates				Statistical Ranking of Average 7-Day Low Flows				
				Period of Record: 1949 - 1995				
1994				Average				
Miller Creek at SR509				7-Day Lows				
				Return				
	Date		Flow / cfs	Year	Ordered	Rank	Rank/(N+1)	Frequency
1949	Sep	7	0.59	1994	0.50	1	0.02	2.08
1950	Sep	17	0.88	1952	0.53	2	0.04	4.17
1951	Sep	17	0.79	1977	0.53	3	0.06	6.25
1952	Nov	23	0.53	1979	0.54	4	0.08	8.33
1953	Sep	15	0.75	1987	0.58	5	0.10	10.42
1954	Oct	3	0.87	1993	0.58	6	0.13	12.50
1955	Sep	6	0.83	1949	0.59	7	0.15	14.58
1956	Sep	3	0.87	1986	0.59	8	0.17	16.67
1957	Sep	20	0.78	1988	0.60	9	0.19	18.75
1958	Sep	29	0.63	1985	0.62	10	0.21	20.83
1959	Aug	24	0.88	1958	0.63	11	0.23	22.92
1960	Sep	29	0.84	1973	0.65	12	0.25	25.00
1961	Sep	29	0.83	1992	0.65	13	0.27	27.08
1962	Sep	3	0.73	1980	0.66	14	0.29	29.17
1963	Sep	27	0.71	1989	0.67	15	0.31	31.25
1964	Oct	25	0.88	1976	0.69	16	0.33	33.33
1965	Sep	27	0.78	1981	0.69	16	0.33	33.33
1966	Sep	3	0.78	1963	0.71	18	0.38	37.50
1967	Sep	22	0.73	1990	0.71	18	0.38	37.50
1968	Aug	7	0.97	1974	0.72	20	0.42	41.67
1969	Sep	6	0.82	1970	0.72	21	0.44	43.75
1970	Aug	27	0.72	1962	0.73	22	0.46	45.83
1971	Aug	14	0.92	1967	0.73	23	0.48	47.92
1972	Sep	11	1.01	1953	0.75	24	0.50	50.00
1973	Sep	12	0.65	1995	0.76	25	0.52	52.08
1974	Oct	13	0.72	1966	0.78	26	0.54	54.17
1975	Aug	11	0.78	1957	0.78	27	0.56	56.25
1976	Dec	10	0.69	1975	0.78	27	0.56	56.25
1977	Aug	16	0.53	1965	0.78	29	0.60	60.42
1978	Aug	17	0.80	1984	0.78	29	0.60	60.42
1979	Oct	7	0.54	1951	0.79	31	0.65	64.58
1980	Oct	17	0.66	1991	0.79	32	0.67	66.67
1981	Sep	12	0.69	1978	0.80	33	0.69	68.75
1982	Sep	17	0.81	1982	0.81	34	0.71	70.83
1983	Oct	10	0.90	1969	0.82	35	0.73	72.92
1984	Oct	1	0.78	1961	0.83	36	0.75	75.00
1985	Sep	29	0.62	1955	0.83	37	0.77	77.08
1986	Oct	18	0.59	1960	0.84	38	0.79	79.17
1987	Oct	24	0.58	1956	0.87	39	0.81	81.25
1988	Sep	11	0.60	1954	0.87	40	0.83	83.33
1989	Oct	3	0.67	1950	0.88	41	0.85	85.42
1990	Sep	25	0.71	1964	0.88	41	0.85	85.42
1991	Oct	9	0.79	1959	0.88	43	0.90	89.58
1992	Sep	16	0.65	1983	0.90	44	0.92	91.67
1993	Nov	9	0.58	1971	0.92	45	0.94	93.75
1994	Oct	6	0.50	1968	0.97	46	0.96	95.83
1995	Sep	20	0.76	1972	1.01	47	0.98	97.92

Rank = Numerical Position of ordered low flow data
with driest year equal to one.

N = 47

BAR GRAPH LOW FLOW OCCURRENCES IN MILLER CREEK (1994)

AR 020093

Low Flow Occurrences in Miller Creek, 1949-1995 (1994 HSPF)

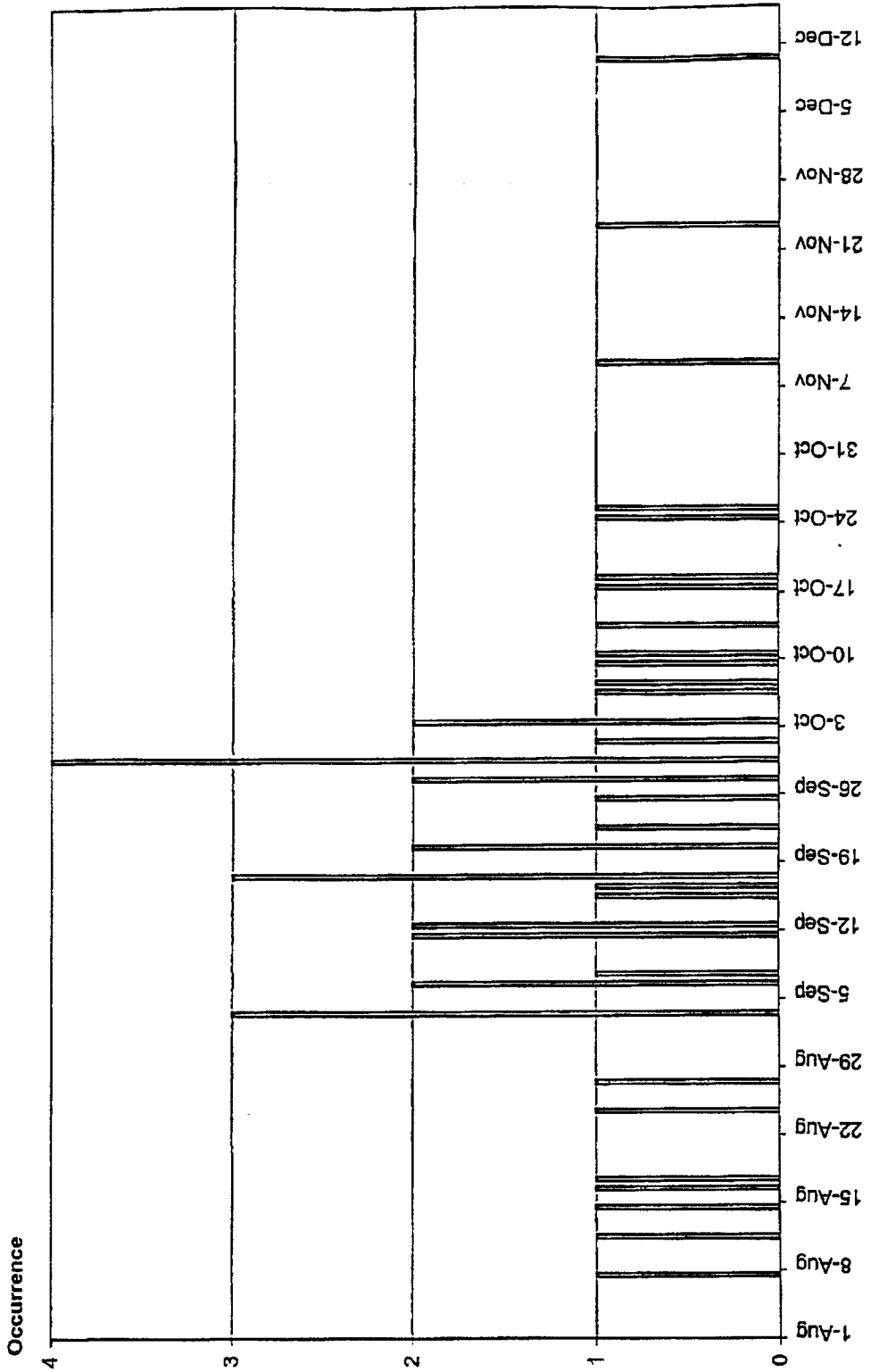

7-DAY LOW FLOW OCCURRENCES IN MILLER CREEK (1991-1994)

AR 020095

Start of 7-Day Low Flows with
Average Flow Rates

Year	Date	1994 Miller Creek at SR509 Flow / cfs
1991	Oct	0.79
1992	Sep	0.65
1993	Nov	0.58
1994	Sep	0.54

Statistical Ranking of Average 7-Day Low Flows
Period of Record: 1949 - 1995

Date	Average 7-Day Lows Ordered	Rank	Rank/(N+1)	Return Frequency
1994	0.54	1	0.20	20.0
1993	0.58	2	0.40	40.0
1992	0.65	3	0.60	60.0
1991	0.79	4	0.80	80.0

Rank = Numerical Position of ordered low flow data
with driest year equal to one.
N = 4

CALCULATION OF 50% RETURN FREQUENCY FOR MILLER CREEK

AR 020097

1994				2006 Miller Creek at Hwy 509				
Date		Miller Creek at Hwy 509 Flow / cfs		Date		2006 - 1994		
1991	Oct	9	0.79	1991	Oct	9	0.82	0.03
1992	Sep	16	0.65	1992	Sep	16	0.68	0.03
1993	Nov	9	0.58	1993	Nov	9	0.63	0.05
1994	Sep	24	0.54	1994	Aug	26	0.58	0.04

RANKED	Year (1994 HSPF)	1994	2006	2006- 1994	Non Hydrologic	Net Impact
	1994	0.54	0.68	0.04	-0.02	0.02
	1993	0.68	0.63	0.05	-0.02	0.03
	1992	0.65	0.68	0.03	-0.02	0.01
	1991	0.79	0.82	0.03	-0.02	0.01

	50th Return Frequency 1994	50th Return Frequency 2006	Mitigation Value 2006 - 1994
2 yrs only	0.7349	0.763	0.028
all 4 yrs	0.7322	0.762	0.030

Return Frequency	modeled 1994	modeled 2006	modeled 2006-1994
2.08	1994	0.54	0.58
12.50	1993	0.68	0.63
27.08	1992	0.65	0.68
68.67	1991	0.79	0.82

50th Return Frequency	1994 slope	2006 slope	1994 intercept	2006 intercept	1994 rf = 60	2006 rf = 60
all 4 years	0.0039	0.0037	0.53	0.58	0.79	0.762
91 and 92 only	0.0036	0.0036	0.66	0.59	0.73	0.763

SUMMARY OUTPUT

Regression Statistics	
Multiple R	0.997736053
R Square	0.995477231
Adjusted R Squ	0.993216847
Standard Error	0.00922213
Observations	4

ANOVA					
	df	SS	MS	F	Significance F
Regression	1	0.037438585	0.037438585	440.206993	0.02283947
Residual	2	0.000170085	8.50477E-05		
Total	3	0.037608681			

	Coefficients	Standard Error	t Stat	P-value	Lower 95%	Upper 95%	Lower 95.0%	Upper 95.0%
Intercept	0.534817591	0.006870687	77.85325651	0.000184938	0.505355474	0.564479707	0.50535547	0.56447971
X Variable 1	0.0038459	0.000186089	20.98111038	0.002283947	0.003136703	0.004755097	0.0031367	0.0047551

SUMMARY OUTPUT

Regression Statistics	
Multiple R	0.998891931
R Square	0.997385573
Adjusted R Squ	0.996078359
Standard Error	0.006525423
Observations	4

ANOVA					
	df	SS	MS	F	Significance F
Regression	1	0.03248882	0.03248882	762.9859383	0.001308069
Residual	2	8.51823E-05	4.25812E-05		
Total	3	0.032573882			

	Coefficients	Standard Error	t Stat	P-value	Lower 95%	Upper 95%	Lower 95.0%	Upper 95.0%
Intercept	0.578199727	0.004861868	118.8327816	7.06889E-06	0.657282073	0.599117361	0.6572821	0.5991174
X Variable 1	0.003675812	0.000139075	27.8222001	0.001308069	0.003103238	0.004248388	0.0031032	0.0042484

COMPARISON OF 7-DAY LOW FLOW BY YEAR

AR 020099

Comparison of 7-Day Low Flow Values by Year
for Miller Creek

	1994		2006	
	Date	Miller Creek at SR509 Flow / cfs	Date	Miller Creek at SR509 Flow / cfs
1991	Oct 9	0.79	1991 Oct 9	0.82
1992	Sep 16	0.65	1992 Sep 16	0.68
1993	Nov 9	0.58	1993 Nov 9	0.63
1994	Sep 24	0.54	1994 Aug 26	0.58
				-1994
				0.03
				0.03
				0.05
				0.04

WALKER CREEK

7-DAY LOW FLOW OCCURRENCES IN WALKER CREEK (1994)

BAR GRAPH LOW FLOW OCCURRENCES IN WALKER CREEK (1994)

7-DAY LOW FLOW OCCURRENCES IN WALKER CREEK (1991-1994)

CALCULATION OF 50% RETURN FREQUENCY FOR WALKER CREEK

SUMMARY OF LOW STREAM FLOW MITIGATION VAULT STORAGE AND FILLING

PLOTTED MINIMUM VOLUME IN WALKER CREEK VAULT AUG 1 - OCT 31, 1949-1995

HISTOGRAM VAULT VOLUME REMAINING ON OCT 31, 1949-1995

AR 020101

7-DAY LOW FLOW OCCURRENCES IN WALKER CREEK (1994)

AR 020102

Start of 7-Day Low Flows with Average Flow Rates				Statistical Ranking of Average 7-Day Low Flows				
				Period of Record: 1949-1995				
				Average 7-Day Lows			Return	
		1994 HSPF Walker Creek at POC		Date	Ordered	Rank	Rank/N+1	Frequency
1949	Oct	17	0.66	1994	0.60	1	0.02	2.1
1950	Sep	13	0.83	1979	0.63	2	0.04	4.2
1951	Sep	11	0.78	1987	0.64	3	0.06	6.3
1952	Nov	15	0.65	1952	0.65	4	0.08	8.3
1953	Sep	5	0.76	1993	0.65	5	0.10	10.4
1954	Sep	30	0.87	1988	0.65	6	0.13	12.5
1955	Aug	23	0.83	1986	0.66	7	0.15	14.6
1956	Sep	2	0.85	1949	0.66	8	0.17	16.7
1957	Sep	2	0.80	1977	0.66	9	0.19	18.8
1958	Sep	10	0.70	1992	0.67	10	0.21	20.8
1959	Aug	2	0.85	1985	0.68	11	0.23	22.9
1960	Sep	20	0.83	1980	0.68	12	0.25	25.0
1961	Sep	4	0.80	1989	0.69	13	0.27	27.1
1962	Aug	23	0.79	1958	0.70	14	0.29	29.2
1963	Sep	6	0.74	1981	0.70	15	0.31	31.3
1964	Aug	8	0.90	1990	0.71	16	0.33	33.3
1965	Aug	24	0.78	1976	0.73	17	0.35	35.4
1966	Aug	25	0.77	1995	0.73	18	0.38	37.5
1967	Aug	15	0.75	1963	0.74	19	0.40	39.6
1968	Jun	28	0.94	1973	0.74	20	0.42	41.7
1969	Jul	26	0.82	1982	0.75	21	0.44	43.8
1970	Sep	2	0.76	1967	0.75	22	0.46	45.8
1971	Jul	10	0.88	1970	0.76	23	0.48	47.9
1972	Jul	25	0.94	1953	0.76	24	0.50	50.0
1973	Jul	24	0.74	1991	0.76	25	0.52	52.1
1974	Aug	22	0.77	1966	0.77	26	0.54	54.2
1975	Jun	18	0.79	1974	0.77	27	0.56	56.3
1976	Oct	15	0.73	1984	0.77	28	0.58	58.3
1977	Jun	19	0.66	1951	0.78	29	0.60	60.4
1978	Jun	26	0.78	1965	0.78	29	0.60	60.4
1979	Aug	6	0.63	1978	0.78	31	0.65	64.6
1980	Aug	14	0.68	1962	0.79	32	0.67	66.7
1981	Jul	8	0.70	1975	0.79	33	0.69	68.8
1982	Jul	23	0.75	1961	0.80	34	0.71	70.8
1983	Aug	1	0.90	1957	0.80	35	0.73	72.9
1984	Jul	21	0.77	1969	0.82	36	0.75	75.0
1985	Jul	27	0.68	1980	0.83	37	0.77	77.1
1986	Aug	3	0.66	1950	0.83	38	0.79	79.2
1987	Aug	16	0.64	1955	0.83	39	0.81	81.3
1988	Jul	18	0.65	1959	0.85	40	0.83	83.3
1989	Jul	13	0.69	1956	0.85	41	0.85	85.4
1990	Jul	3	0.71	1954	0.87	42	0.88	87.5
1991	Aug	3	0.76	1971	0.88	43	0.90	89.6
1992	Jul	26	0.67	1964	0.90	44	0.92	91.7
1993	Aug	11	0.65	1983	0.90	44	0.92	91.7
1994	Jul	18	0.60	1972	0.94	46	0.96	95.8
1995	Jun	18	0.73	1968	0.94	47	0.98	97.9
				Rank = Numerical position of ordered low flow data with the driest year equal to one.				
				N = 47				

BAR GRAPH LOW FLOW OCCURRENCES IN WALKER CREEK (1994)

AR 020104



7-Day Low Flow Occurrences in Walker Creek, 1949-1995 (1994 HSPF)

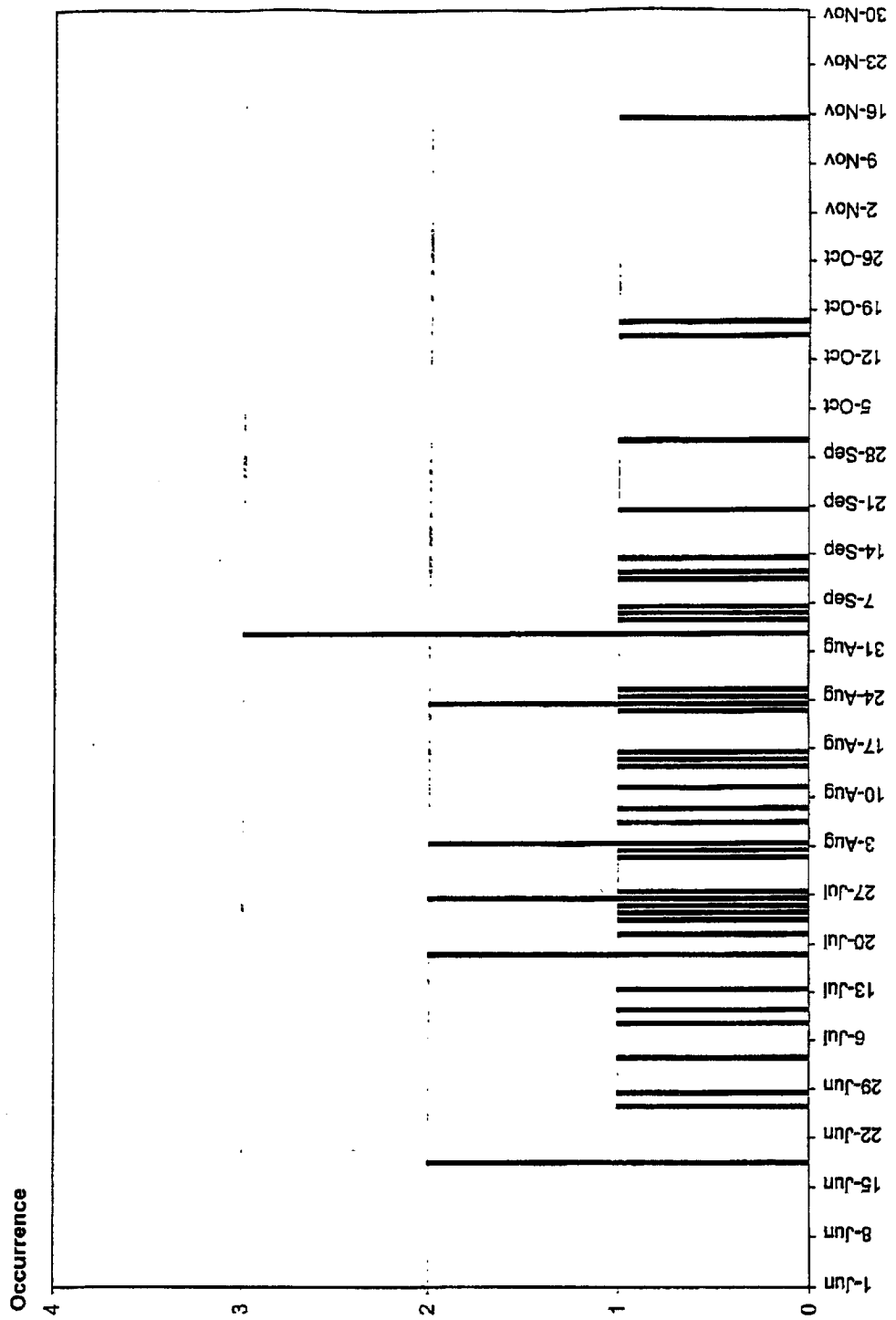

7-DAY LOW FLOW OCCURRENCES IN WALKER CREEK (1991-1994)

Start of 7-Day Low Flows with
Average Flow Rates

Statistical Ranking of Average 7-Day Low Flows
Period of Record: 1991-1994

Date			1994 Walker Creek at POC	Date	Average 7-Day Lows Ordered	Rank	Rank/N+1	Return Frequency
1991	Oct	9	0.77	1994	0.64	1	0.2	20
1992	Oct	22	0.67	1993	0.65	2	0.4	40
1993	Nov	9	0.65	1992	0.67	3	0.6	60
1994	Sep	24	0.64	1991	0.77	4	0.8	80

Rank = Numerical position of ordered low flow data with the
driest year equal to one.
N = 4

AR 020107

CALCULATION OF 50% RETURN FREQUENCY FOR WALKER CREEK

AR 020108

Calculation of 50% Return Frequency

Date Yr	Mnth	7 day low flow
1991	Oct	0.77
1992	Oct	0.67
1993	Nov	0.65
1994	Sep	0.64

Date Yr	Mnth	7 day low flow
1991	Oct	0.67
1992	Oct	0.59
1993	Nov	0.57
1994	Sep	0.55

Date	7 day low flow	Rank	Rank/4+1	Return Frequency	Slope	Y intercept at 50% RF
24-Sep-94	0.64	1	0.2	20	0.0022	0.576
9-Nov-93	0.65	2	0.4	40		0.68
22-Oct-92	0.67	3	0.6	60		
9-Oct-91	0.77	4	0.8	80		

Date	7 day low flow	Rank	Rank/4+1	Return Frequency	Slope	Y intercept at 50% RF
24-Sep-94	0.55	1	0.2	20	0.0027	0.448
9-Nov-93	0.57	2	0.4	40		0.58
22-Oct-92	0.59	3	0.6	60		
9-Oct-91	0.67	4	0.8	80		

Mitigation value calculated using difference in 80% return frequency (RF)
0.10

Mitigation value calculated using difference in 50% return frequency (RF)
0.10

SUMMARY OF LOW STREAM FLOW MITIGATION VAULT STORAGE AND FILLING

AR 020110

Reserve Storage Vaults for Walker Creek			
Vault sizes (dead storage in acre ft) required for 92-day release of 0.11 cfs (1949 - 1985).			
	SDS3a		
Mean	12.79		
Median	12.83		
Max	18.41		
Min	5.40		
Contributing Drainage Areas		Impervious Area	
Subbasin	Vault A	Acre	
SDS3A	SDS3a-LF	14.6	
SDW2		11.5	
SUM		26.1	
Fill time for 18.5 acre foot volume / Days to fill starting on January 2.			
Mean	71		
Median	60		
Max	213		
Min	22		
Remaining volume in vaults on Oct 31			
	Volume	Remaining	
	ac ft	Days	
Mean	8.49	77.19	
Median	8.05	73.19	
Max	18.68	169.84	
Min	0.65	5.94	

PLOTTED MINIMUM VOLUME IN WALKER CREEK VAULT AUG 1 - OCT 31, 1949-1995

AR 020112

Minimum Volume in Walker Creek Vault from Aug 1 - Oct 31 (1949 - 1995)

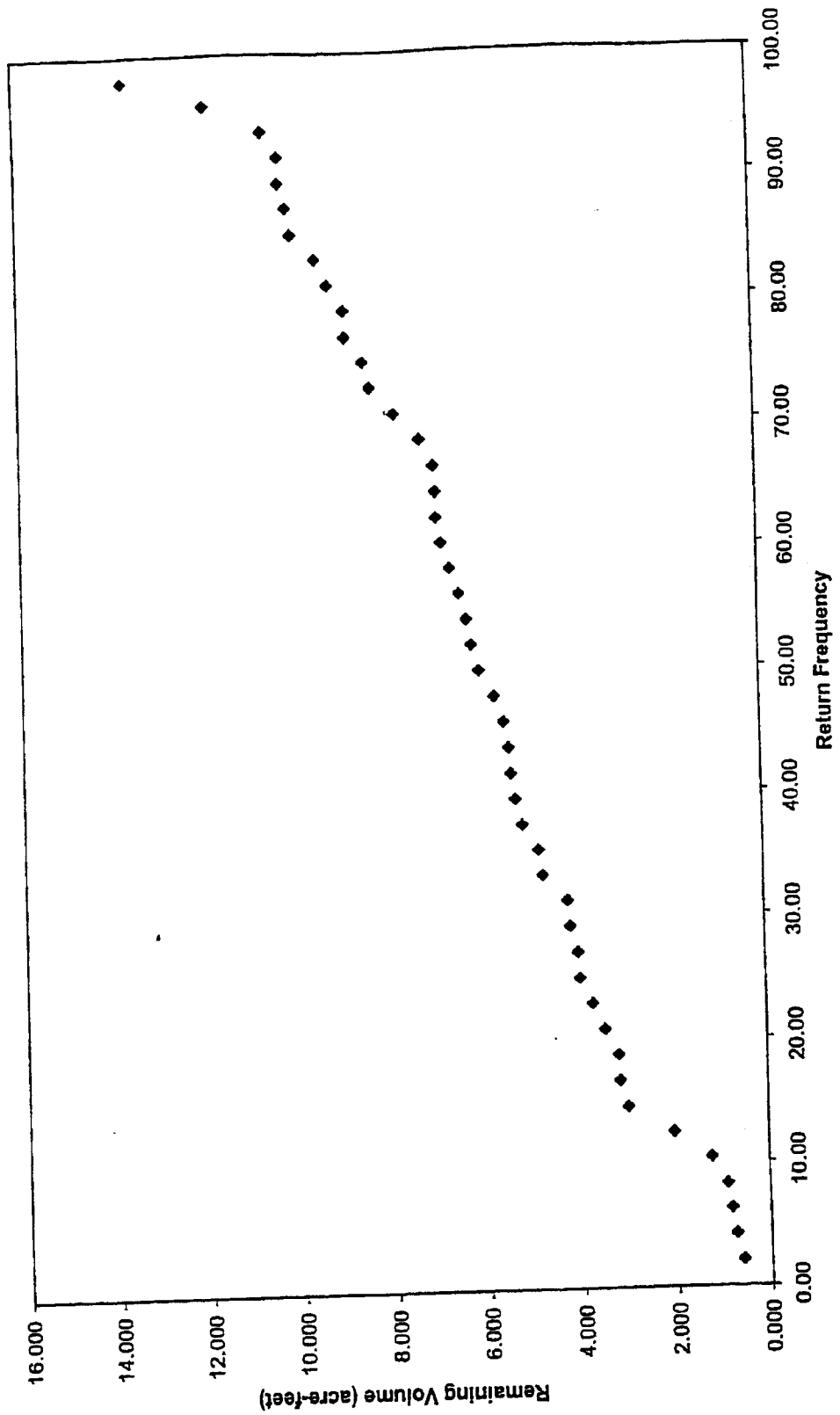

HISTOGRAM VAULT VOLUME REMAINING ON OCT 31, 1949-1995

AR 020114

Vault Volume Remaining On October 31, 1949-1994 (Vault Size = 19.0 ac-ft)

Frequency —■— Cumulative %

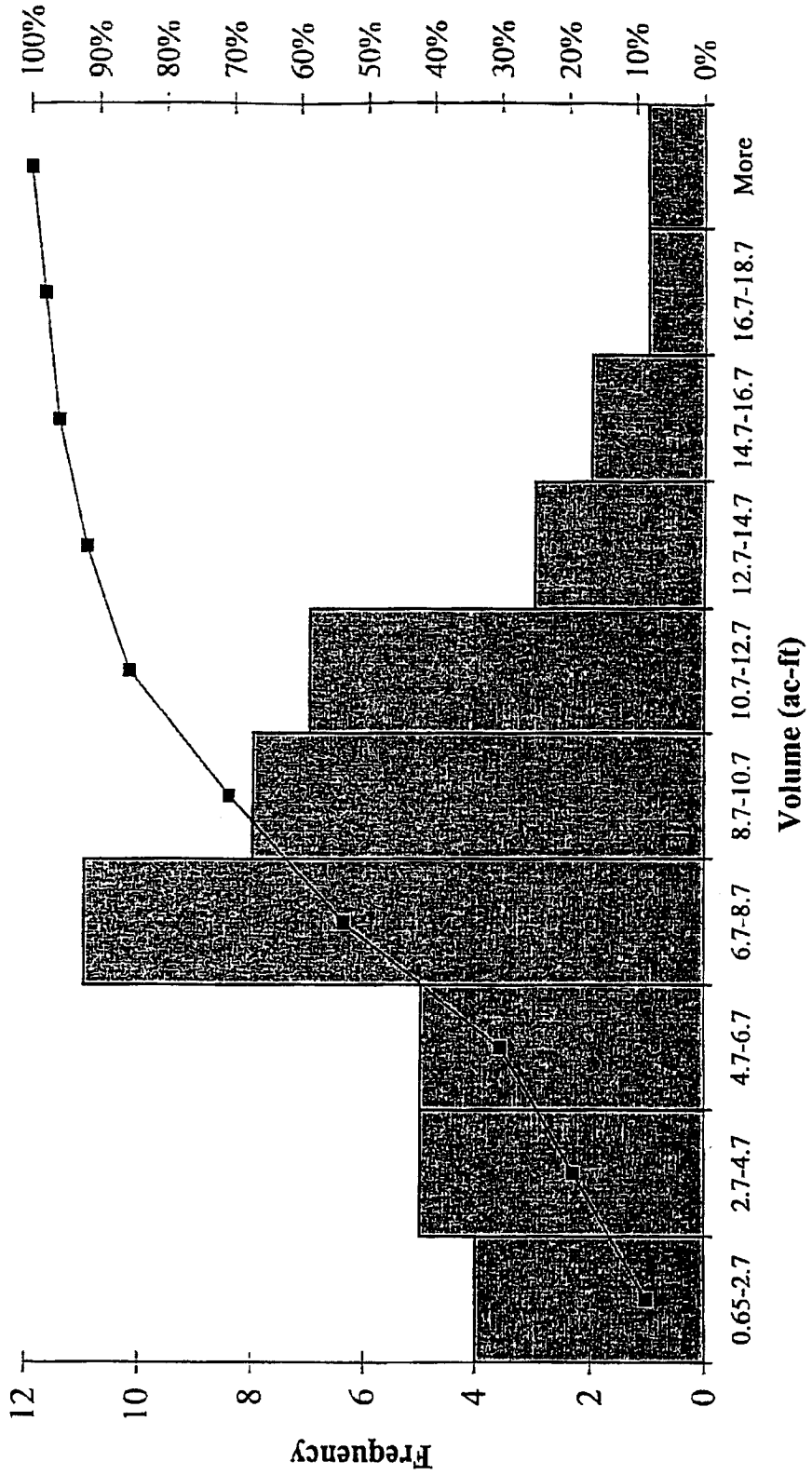

DES MOINES CREEK

7-DAY LOW FLOW OCCURRENCES IN DES MOINES CREEK (1994)

BAR GRAPH LOW FLOW OCCURRENCES IN DES MOINES CREEK (1994)

7-DAY LOW FLOW OCCURRENCES IN DES MOINES CREEK (2006)

BAR GRAPH LOW FLOW OCCURRENCES IN DES MOINES CREEK (2006)

LOW FLOW OCCURRENCES IN DES MOINES CREEK (WITH MITIGATION)

**BAR GRAPH LOW FLOW OCCURRENCES IN DES MOINES CREEK
(WITH MITIGATION)**

SUMMARY OF LOW STREAM FLOW MITIGATION VAULT STORAGE AND FILLING

PLOTTED MINIMUM VOLUME IN DES MOINES VAULT JUL 24-OCT 24, 1949-1995

HISTOGRAM VAULT VOLUME REMAINING ON OCT 24, 1949-1995

AR 020116

7-DAY LOW FLOW OCCURRENCES IN DES MOINES CREEK (1994)

Start of 7-Day Low Flows with Average Flow Rates				Statistical Ranking of Average 7-Day Low Flows				
				Period of Record: 1949 - 1995				
1994 HSPF								
Des Moines Creek at 200th St. / Flow cfs				Average 7-Day Lows				
Average 7-Day Low Flow				Year	Ordered	Rank	Rank/(47+1)	Return Frequency
1949	Sep	7	0.18	1977	0.17	1	0.02	2.1
1950	Sep	17	0.40	1949	0.18	2	0.04	4.2
1951	Aug	20	0.35	1952	0.21	3	0.06	6.3
1952	Oct	13	0.21	1994	0.22	4	0.08	8.3
1953	Sep	15	0.35	1979	0.22	5	0.10	10.4
1954	Aug	7	0.48	1988	0.25	6	0.13	12.5
1955	Sep	6	0.34	1985	0.25	7	0.15	14.6
1956	Sep	3	0.43	1986	0.26	8	0.17	16.7
1957	Sep	20	0.32	1993	0.27	9	0.19	18.8
1958	Sep	2	0.27	1973	0.27	10	0.21	20.8
1959	Aug	24	0.38	1958	0.27	11	0.23	22.9
1960	Aug	7	0.39	1981	0.28	12	0.25	25.0
1961	Aug	23	0.40	1987	0.29	13	0.27	27.1
1962	Sep	2	0.33	1990	0.31	14	0.29	29.2
1963	Sep	27	0.36	1974	0.31	15	0.31	31.3
1964	Aug	31	0.47	1992	0.31	16	0.33	33.3
1965	Aug	3	0.38	1966	0.32	17	0.35	35.4
1966	Aug	20	0.32	1987	0.32	18	0.38	37.5
1967	Aug	25	0.33	1970	0.33	19	0.40	39.6
1968	Aug	6	0.47	1975	0.33	20	0.42	41.7
1969	Sep	6	0.36	1962	0.33	21	0.44	43.8
1970	Aug	27	0.33	1980	0.33	22	0.46	45.8
1971	Aug	14	0.41	1991	0.33	22	0.46	45.8
1972	Oct	18	0.51	1967	0.33	24	0.50	50.0
1973	Sep	12	0.27	1976	0.34	25	0.52	52.1
1974	Oct	13	0.31	1955	0.34	26	0.54	54.2
1975	Aug	11	0.33	1951	0.35	27	0.56	56.3
1976	Oct	17	0.34	1995	0.35	27	0.56	56.3
1977	Aug	16	0.17	1953	0.35	29	0.60	60.4
1978	Oct	16	0.41	1989	0.35	30	0.63	62.5
1979	Aug	7	0.22	1984	0.36	31	0.65	64.6
1980	Aug	23	0.33	1963	0.36	32	0.67	66.7
1981	Sep	12	0.28	1965	0.38	33	0.69	68.8
1982	Aug	6	0.41	1969	0.38	34	0.71	70.8
1983	Oct	10	0.45	1959	0.38	35	0.73	72.9
1984	Aug	29	0.36	1960	0.39	36	0.75	75.0
1985	Aug	30	0.25	1961	0.40	37	0.77	77.1
1986	Sep	10	0.26	1950	0.40	38	0.79	79.2
1987	Sep	7	0.29	1971	0.41	39	0.81	81.3
1988	Sep	11	0.25	1978	0.41	40	0.83	83.3
1989	Oct	3	0.35	1982	0.41	41	0.85	85.4
1990	Sep	25	0.31	1956	0.43	42	0.88	87.5
1991	Oct	9	0.33	1983	0.45	43	0.90	89.6
1992	Sep	1	0.31	1964	0.47	44	0.92	91.7
1993	Sep	29	0.27	1968	0.47	44	0.92	91.7
1994	Aug	26	0.22	1954	0.48	46	0.95	95.8
1995	Sep	20	0.35	1972	0.51	47	0.98	97.9

Rank = Numerical position of ordered average 7-day low flow values with the driest year equal to one.
N = 47

BAR GRAPH LOW FLOW OCCURRENCES IN DES MOINES CREEK (1994)

AR 020119

7-Day Low Flow Occurrences in Des Moines Creek, 1949-1995 (1994 HSPF)

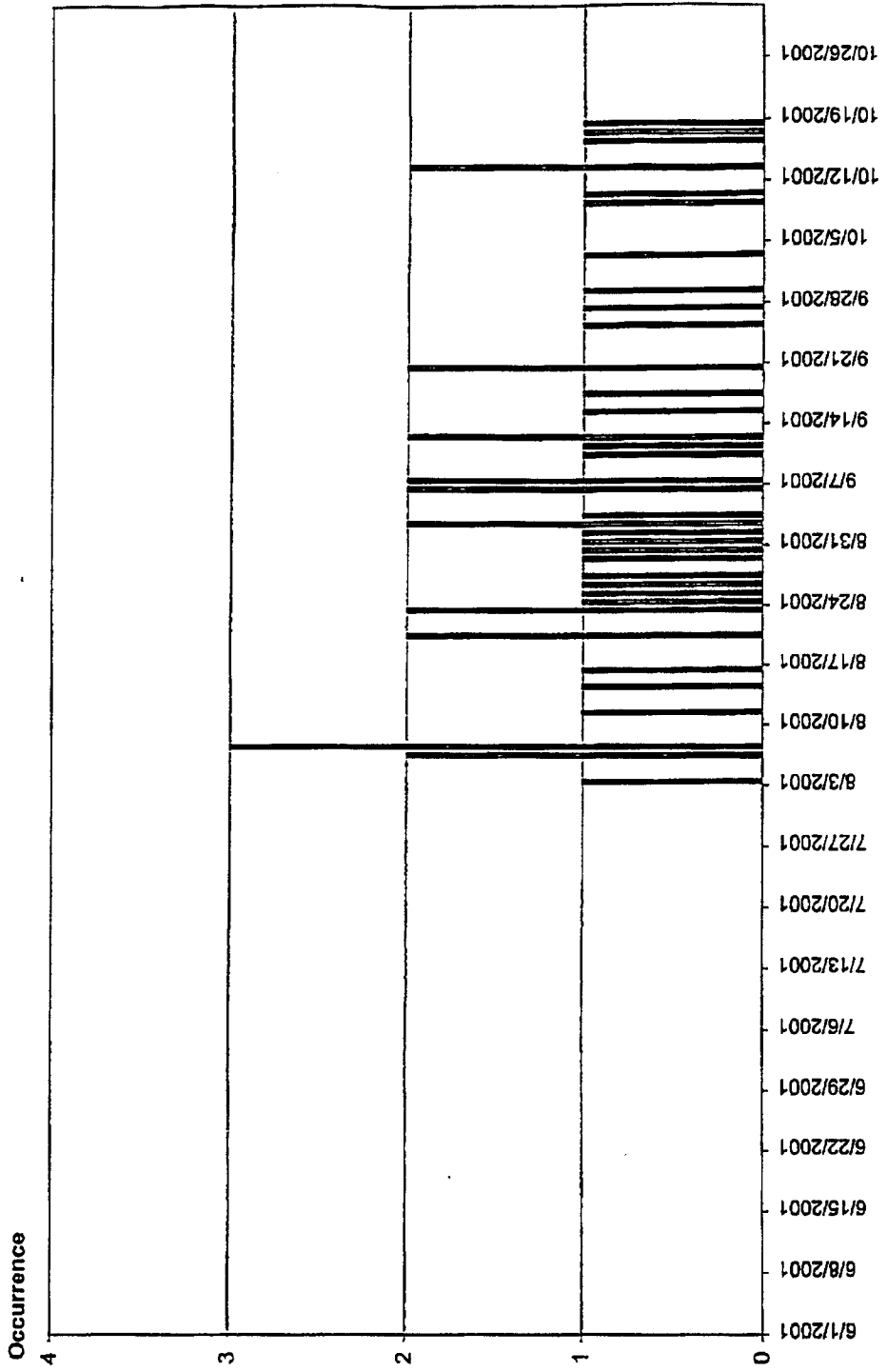

7-DAY LOW FLOW OCCURRENCES IN DES MOINES CREEK (2006)

AR 020121

Start of 7-Day Low Flows with Average Flow Rates				Statistical Ranking of Average 7-Day Low Flows Period of Record: 1949 - 1995				
2006 HSPF Des Moines Creek at 200th St. / Flow cfs								
Date	Average 7-Day Low Flow			Year	Average 7-Day Lows Ordered	Rank	Rank/(47+1)	Return Frequency
1949	Sep	7	0.14	1977	0.12	1	0.02	2.1
1950	Sep	17	0.33	1949	0.14	2	0.04	4.2
1951	Aug	20	0.25	1952	0.15	3	0.06	6.3
1952	Oct	13	0.15	1994	0.16	4	0.08	8.3
1953	Sep	15	0.29	1978	0.17	5	0.10	10.4
1954	Aug	7	0.38	1988	0.19	6	0.13	12.5
1955	Sep	6	0.28	1986	0.19	7	0.15	14.6
1956	Sep	3	0.36	1958	0.20	8	0.17	16.7
1957	Sep	20	0.25	1985	0.20	8	0.17	16.7
1958	Sep	2	0.20	1993	0.20	8	0.17	16.7
1959	Aug	24	0.29	1973	0.20	11	0.23	22.9
1960	Aug	7	0.29	1981	0.21	12	0.25	25.0
1961	Aug	23	0.31	1987	0.22	13	0.27	27.1
1962	Sep	3	0.28	1974	0.23	14	0.29	29.2
1963	Sep	27	0.31	1990	0.24	15	0.31	31.3
1964	Aug	31	0.40	1986	0.24	16	0.33	33.3
1965	Aug	3	0.30	1967	0.24	17	0.35	35.4
1966	Aug	20	0.24	1992	0.25	18	0.38	37.5
1967	Aug	25	0.24	1975	0.25	19	0.40	39.6
1968	Aug	7	0.38	1957	0.25	20	0.42	41.7
1969	Sep	6	0.29	1951	0.25	21	0.44	43.8
1970	Jul	18	0.25	1970	0.25	21	0.44	43.8
1971	Aug	14	0.31	1991	0.26	23	0.48	47.9
1972	Aug	8	0.42	1955	0.26	24	0.50	50.0
1973	Sep	11	0.20	1980	0.26	24	0.50	50.0
1974	Oct	13	0.23	1976	0.27	26	0.54	54.2
1975	Aug	11	0.25	1984	0.27	26	0.54	54.2
1976	Oct	17	0.27	1962	0.28	26	0.58	58.3
1977	Aug	16	0.12	1959	0.29	29	0.60	60.4
1978	Jul	9	0.34	1953	0.29	30	0.63	62.5
1979	Aug	7	0.17	1980	0.29	31	0.65	64.6
1980	Aug	23	0.26	1989	0.29	32	0.67	66.7
1981	Sep	12	0.21	1995	0.30	33	0.69	68.8
1982	Aug	6	0.33	1965	0.30	34	0.71	70.8
1983	Oct	10	0.41	1989	0.30	35	0.73	72.9
1984	Aug	29	0.27	1961	0.31	36	0.75	75.0
1985	Aug	30	0.20	1963	0.31	37	0.77	77.1
1986	Sep	6	0.19	1971	0.31	38	0.79	79.2
1987	Sep	6	0.22	1950	0.33	39	0.81	81.3
1988	Sep	11	0.19	1982	0.33	40	0.83	83.3
1989	Aug	7	0.30	1978	0.34	41	0.85	85.4
1990	Sep	25	0.24	1956	0.36	42	0.88	87.5
1991	Oct	9	0.26	1968	0.38	43	0.90	89.6
1992	Sep	16	0.25	1954	0.38	44	0.92	91.7
1993	Sep	29	0.20	1964	0.40	45	0.94	93.8
1994	Aug	26	0.16	1983	0.41	46	0.96	95.8
1995	Sep	20	0.30	1972	0.42	47	0.98	97.9

Rank = Numerical position of ordered average 7-day low flow
values with the driest year equal to one.
N = 47

BAR GRAPH LOW FLOW OCCURRENCES IN DES MOINES CREEK (2006)

AR 020123



7-Day Low Flow Occurrences in Des Moines Creek, 1949-1995 (2006 HSPF)

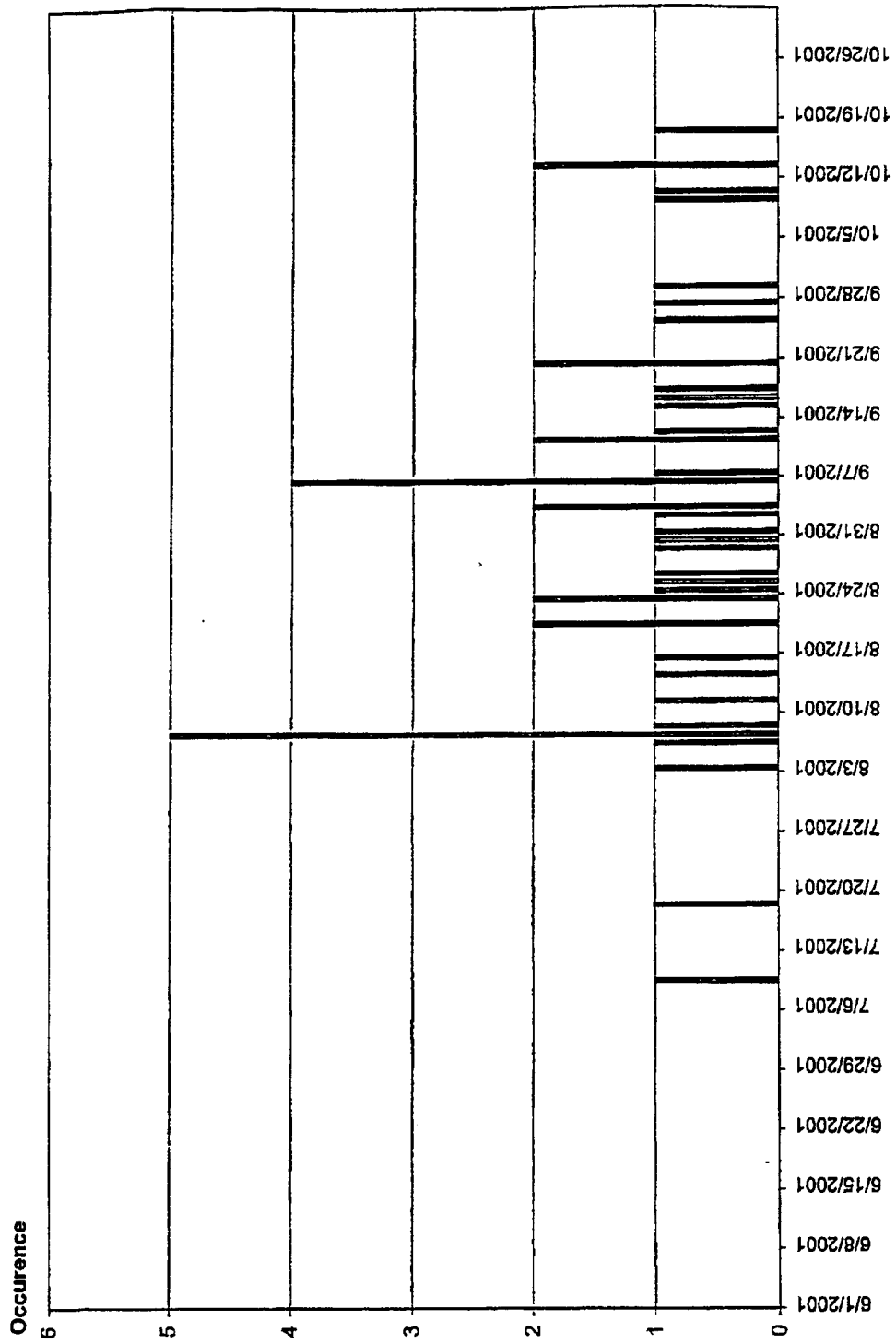

LOW FLOW OCCURRENCES IN DES MOINES CREEK (WITH MITIGATION)

AR 020125

Start of 7-Day Low Flows with Average Flow Rates				Statistical Ranking of Average 7-Day Low Flows				
2006 HSPF				Period of Record: 1949 - 1995				
Des Moines Creek at 200th St / Flow cfs				Average 7-Day Lows				
Average 7-Day Low Flow Jul24-Oct24 Release 0.08				Return				
Date				Year	Ordered	Rank	Rank/(47+1)	Frequency
1949	Sep	7	0.22	1977	0.20	1	0.02	2.1
1950	Sep	17	0.41	1949	0.22	2	0.04	4.2
1951	Aug	20	0.33	1979	0.23	3	0.06	6.3
1952	Oct	13	0.23	1952	0.23	4	0.08	8.3
1953	Sep	15	0.37	1994	0.24	5	0.10	10.4
1954	Aug	7	0.46	1985	0.24	6	0.13	12.5
1955	Sep	6	0.34	1970	0.26	7	0.15	14.6
1956	Sep	3	0.44	1988	0.27	8	0.17	16.7
1957	Sep	20	0.33	1987	0.27	9	0.19	18.8
1958	Sep	2	0.28	1986	0.27	10	0.21	20.8
1959	Aug	24	0.37	1958	0.28	11	0.23	22.9
1960	Aug	7	0.37	1993	0.28	11	0.23	22.9
1961	Aug	23	0.39	1973	0.28	13	0.27	27.1
1962	Sep	3	0.36	1981	0.29	14	0.29	29.2
1963	Sep	27	0.39	1974	0.31	15	0.31	31.3
1964	Aug	31	0.48	1990	0.32	16	0.33	33.3
1965	Jul	13	0.36	1966	0.32	17	0.35	35.4
1966	Aug	20	0.32	1967	0.32	18	0.38	37.5
1967	Aug	25	0.32	1992	0.33	19	0.40	39.6
1968	Aug	7	0.46	1975	0.33	20	0.42	41.7
1969	Sep	6	0.37	1957	0.33	21	0.44	43.8
1970	Jul	17	0.26	1951	0.33	22	0.46	45.8
1971	Aug	14	0.39	1991	0.34	23	0.48	47.9
1972	Aug	8	0.50	1955	0.34	24	0.50	50.0
1973	Sep	11	0.28	1976	0.34	24	0.50	50.0
1974	Oct	13	0.31	1978	0.34	24	0.50	50.0
1975	Aug	11	0.33	1980	0.34	24	0.50	50.0
1976	Nov	30	0.34	1984	0.35	28	0.58	58.3
1977	Aug	16	0.20	1962	0.35	29	0.60	60.4
1978	Jul	9	0.34	1965	0.36	29	0.60	60.4
1979	Jun	23	0.23	1959	0.37	31	0.65	64.6
1980	Aug	23	0.34	1982	0.37	31	0.65	64.6
1981	Sep	12	0.29	1953	0.37	33	0.69	68.8
1982	Jun	19	0.37	1960	0.37	34	0.71	70.8
1983	Oct	10	0.49	1969	0.37	35	0.73	72.9
1984	Aug	29	0.35	1995	0.38	36	0.75	75.0
1985	Jul	17	0.24	1989	0.38	37	0.77	77.1
1986	Sep	6	0.27	1961	0.39	38	0.79	79.2
1987	Oct	24	0.27	1963	0.39	39	0.81	81.3
1988	Sep	11	0.27	1971	0.39	40	0.83	83.3
1989	Aug	7	0.38	1950	0.41	41	0.85	85.4
1990	Sep	25	0.32	1956	0.44	42	0.88	87.5
1991	Oct	9	0.34	1968	0.46	43	0.90	89.6
1992	Sep	16	0.33	1954	0.46	44	0.92	91.7
1993	Oct	29	0.26	1964	0.48	45	0.94	93.8
1994	Jul	17	0.24	1983	0.49	46	0.96	95.8
1995	Sep	20	0.36	1972	0.50	47	0.98	97.9

Rank = Numerical position of ordered average 7-day low flow values with the driest year equal to one.
N = 47

**BAR GRAPH LOW FLOW OCCURRENCES IN DES MOINES CREEK (WITH
MITIGATION)**

AR 020127

7-Day Low Flow Occurrences in Des Moines Creek 1994-1995 (2006 HSPF + 0.08)

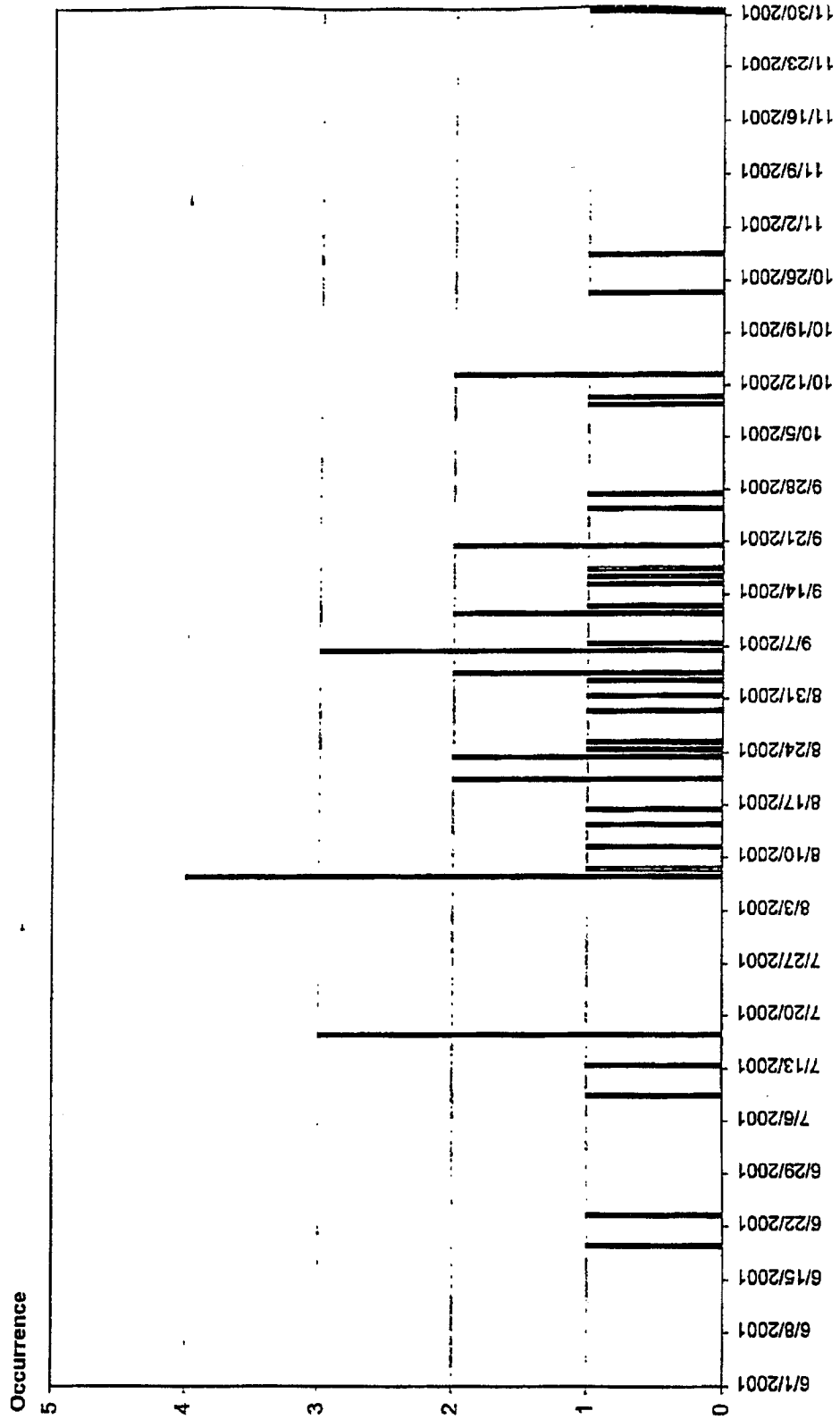

SUMMARY OF LOW STREAM FLOW MITIGATION VAULT STORAGE AND FILLING

AR 020129

Reserve Storage Vaults for Des Moines Creek

Vault sizes (dead storage in acre ft) required for 92-day release of 0.08 cfs (1949 - 1995).

	<u>SDS3</u>
Mean	5.86
Median	5.40
Max	13.47
Min	3.17

Contributing Drainage Areas

<u>Subbasin</u>	<u>Vault</u>	<u>Area</u>
SDS3	SDS3-LF	195.9

Fill time for 13.5 acre foot volume / Days to fill starting on January 2.

Mean	11
Median	8
Max	38
Min	1

Remaining volume in vaults on October 24

	<u>Volume</u>	<u>Remaining</u>
	<u>ac ft</u>	<u>Days</u>
Mean	12.51	79
Median	13.20	83
Max	13.50	85
Min	4.79	30

PLOTTED MINIMUM VOLUME IN DES MOINES VAULT JUL 24-OCT 24, 1949-1995

AR 020131

Minimum Volume in Des Moines Vault Jul 24-Oct 24, 1949-1995

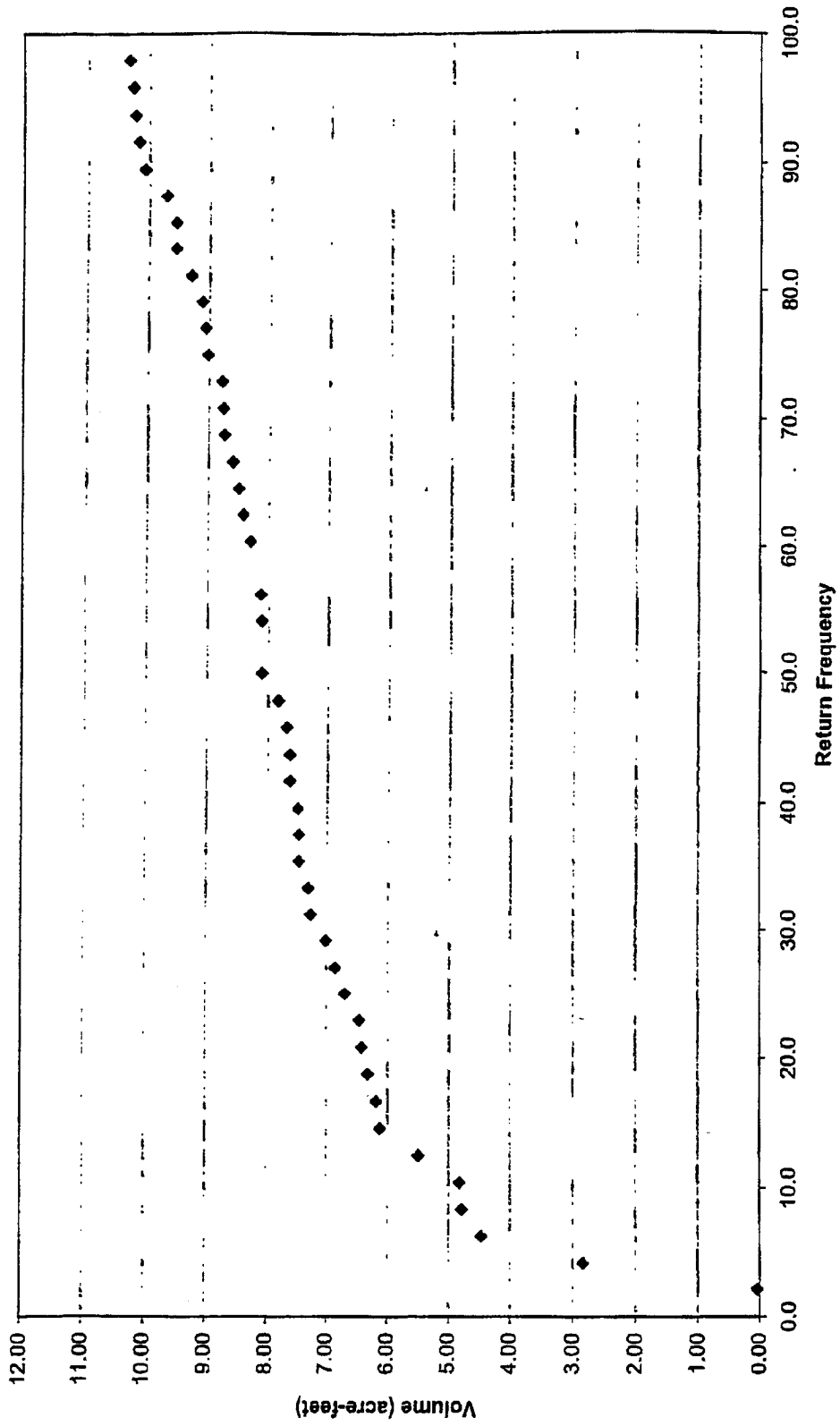

HISTOGRAM VAULT VOLUME REMAINING ON OCT 24, 1949-1995

AR 020133

Vault Volume Remaining On October 24, 1949-1995 (Vault Size = 13.50 ac-ft)

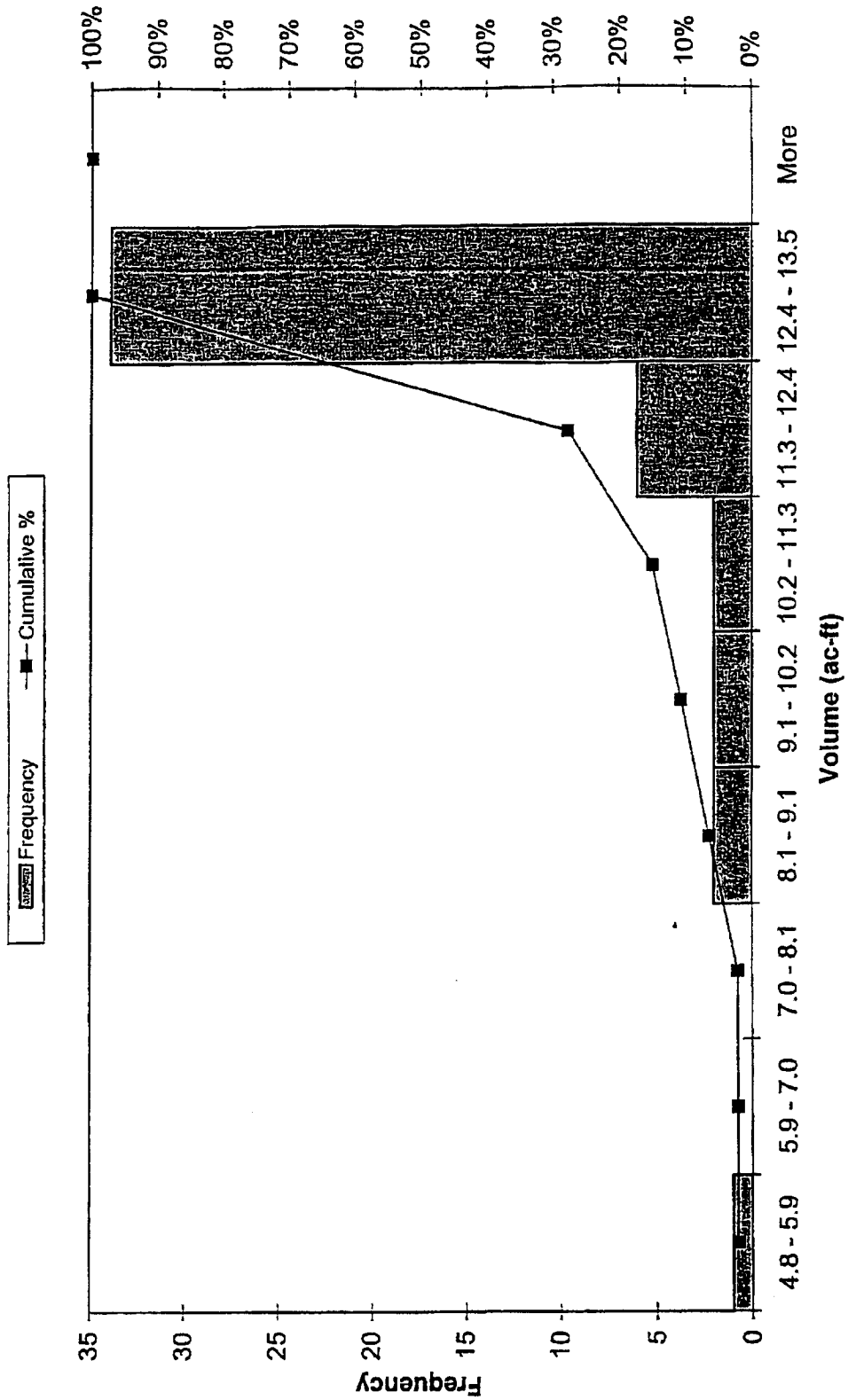



APPENDIX J
HSPF INPUT FILES FOR LOW FLOW VAULT SIZING

AR 020136

implow

```

RUN
GLOBAL
*** FILE: IMPFILL.INP
*** Based on calibration file for Des Moines Creek
*** HSPF Model of runoff from impervious surface
SEATAC AIRPORT HSPF MODEL
START 1948/10/01 00:00 END 1996/09/30 24:00
RUN INTERP OUTPUT LEVEL 4
RESUME 0 RUN 1
END GLOBAL

```

```

FILES
MESSU 24 C:\HSPF\IMFLOW.MES
WDM 25 C:\HSPF\IMFLOW.WDM
END FILES

```

```

OPN SEQUENCE
INGRP INDELT 01:00
  PERLND 16
  PERLND 26
  PERLND 34
  PERLND 44
  PERLND 54
  IMPLND 14
  COPY 20
  COPY 30
  COPY 40
END INGRP
END OPN SEQUENCE

```

```

PERLND
GEN-INFO
<PLS > Name NBLKS Unit-systems Printer ***
# - # User t-series Engl Metr ***
in out
16 TFM- TILL FOR MOD 1 1 1 1 60 0
26 TGM- TILL GR MOD 1 1 1 1 60 0
34 OF - OUTWASH FOR 1 1 1 1 60 0
44 OG - OUTWASH GR 1 1 1 1 60 0
54 SA - WETLANDS 1 1 1 1 60 0
END GEN-INFO

```

```

ACTIVITY
<PLS > ***** Active Sections ***** ***
# - # ATMP SNOW PWAT SED PST PWG PQAL MSTL PEST NITR PHOS TRAC ***
14 54 0 0 1 0 0 0 0 0 0 0 0 0
END ACTIVITY

```

```

PRINT-INFO
<PLS > ***** Print-flags ***** PIVL PYR
# - # ATMP SNOW PWAT SED PST PWG PQAL MSTL PEST NITR PHOS TRAC *****
14 54 0 0 6 0 0 0 0 0 0 0 0 0 1 9
END PRINT-INFO

```

```

PWAT-PARM1
<PLS > ***** Flags ***** ***
# - # CSNO RTOP UZFG VCS VUZ VNN VIFW VIRC VLE ***
14 54 0 0 0 0 0 0 0 0 0 0
END PWAT-PARM1

```

```

PWAT-PARM2
<PLS > ***
# - # ***FOREST LZSN INFILT LSUR SLSUR KVARY AGWRC
16 4.5000 0.2000 200.00 0.1000 0.5000 0.9960
26 4.5000 0.0750 400.00 0.1000 0.5000 0.9960
34 5.0000 2.0000 200.00 0.0500 0.3000 0.9960

```

```

      44          5.0000  0.8000implow 200.00  0.0500  0.3000  0.9960
      54          4.0000  2.0000  200.00  0.0010  0.5000  0.9960
END PWAT-PARM2
PWAT-PARM3
<PLS >***
# - #**** PETMAX    PETMIN    INFEXP    INFILD    DEEPFR    BASETP    AGWETP
16          2.0000  2.0000    0.55     0.00     0.00     0.00     0.0
26          2.0000  2.0000    0.55     0.00     0.00     0.00     0.0
34          2.0000  2.0000    0.55     0.00     0.00     0.00     0.0
44          2.0000  2.0000    0.55     0.00     0.00     0.00     0.0
54          10.000  2.0000    0.55     0.00     0.00     0.00     0.7

```

```

END PWAT-PARM3
PWAT-PARM4
<PLS >
# - #          CEPSC    UZSN    NSUR    INTFW    IRC    LZETP***
16          0.2000  0.5000  0.3500  3.000  0.5000  0.7000
26          0.1000  0.2500  0.2500  3.000  0.5000  0.2500
34          0.2000  0.5000  0.3500  0.000  0.7000  0.7000
44          0.1000  0.5000  0.2500  0.000  0.7000  0.2500
54          0.2000  3.0000  0.5000  1.000  0.7000  0.8000

```

```

PWAT-STATE1
<PLS > PWATER state variables***
# - #**** CEPS    SURS    UZS    IFWS    LZS    AGWS    GWVS
16          0.078    0.    0.0010  0.    0.075  0.267  0.026
26          0.051    0.    0.0350  0.    1.928  0.680  0.049
34          0.078    0.    0.0010  0.    0.090  0.676  0.038
44          0.051    0.    0.0040  0.    1.127  0.614  0.152
54          0.051    0.    0.3330  0.    0.622  0.000  0.000

```

```

END PWAT-STATE1
END PERLND

```

```

IMPLND
GEN-INFO
<ILS >          Name          Unit-systems  Printer
# - #          User t-series Eng] Metr
# - #          in out
14    IMPERVIOUS          1    1    1    60    0
END GEN-INFO

```

```

ACTIVITY
<ILS > ***** Active Sections ****
# - # ATMP SNOW IWAT SLD IWG IQAL ***
14    0    0    1    0    0    0
END ACTIVITY

```

```

PRINT-INFO
<ILS > ***** Print-flags ***** PIVL PYR
# - # ATMP SNOW IWAT SLD IWG IQAL *****
14    0    0    6    0    0    0    1    9
END PRINT-INFO

```

```

IWAT-PARM1
<ILS >          Flags
# - # CSNO RTOP VRS VNN RTLI
14    0    0    0    0    0
END IWAT-PARM1

```

```

IWAT-PARM2
<ILS >
# - #          LSUR    SLSUR    NSUR    RETSC ***
14    500.0  0.0100  0.1000  0.100
END IWAT-PARM2

```

```

IWAT-PARM3
<ILS >
# - #          PETMAX    PETMIN

```

implow

```

14
END IWAT-PARM3
IWAT-STATE1
  <ILS > IWATER state variables
  # - # RETS SURS
  14 1.0000E-3 1.0000E-3
END IWAT-STATE1
END IMPLND

```

```

COPY
TIMESERIES
Copy-opn
# - # NPT NMN
1 60 1
END TIMESERIES
END COPY

```

```

EXT SOURCES
<-Volume-> <Member> SsysSgap<--Mult-->Tran <-Target vols> <-Grp> <-Member-> ***
<Name> # <Name> # tem strg<-factor->strg <Name> # # <Name> # # ***
WDM 1 EVAP ENGLZERO 0.8 PERLND 14 54 EXTNL PETINP
WDM 1 EVAP ENGLZERO 0.8 IMPLND 14 EXTNL PETINP
WDM 2 PREC ENGLZERO PERLND 14 54 EXTNL PREC
WDM 2 PREC ENGLZERO IMPLND 14 EXTNL PREC
END EXT SOURCES

```

```

EXT TARGETS
<-Volume-> <-Grp> <-Member-><--Mult-->Tran <-Volume-> <Member> Tsys Tgap Amd ***
<Name> # <Name> # #<-factor->strg <Name> # <Name> tem strg strg***
*****
*** Multiplication Factor of 12.1 applied for unit conversion
*** from acre-ft/hr to cfs
*****
*** Des Moines Creek Impervious Surface
*****
COPY 20 OUTPUT MEAN 1 12.1 WDM 20 FLOW ENGL REPL
*****
*** Walker Creek Impervious Surface
*****
COPY 30 OUTPUT MEAN 1 12.1 WDM 30 FLOW ENGL REPL
*****
*** Miller Creek Impervious Surface
*****
COPY 40 OUTPUT MEAN 1 12.1 WDM 40 FLOW ENGL REPL
*****
END EXT TARGETS

```

```

NETWORK
***
<MEMBER> SsysSgap<--MULT-->TRAN <-TARGET VOLLS> <-MEMBER->
<NAME> # <NAME> TEM STRG<-FACTOR->STRG <NAME> # # <-GRP> <NAME> # # ***
*****
*** Multiplication Factor of 0.08333 applied to total area for unit conversion
*** from inches to feet
*****
*** Des Moines Creek Impervious Surface
*** 199.17 ac EIA for SDS-3 minus 3.27 ac area unable to plumb
*** Result is 195.90 ac impervious surface
*****
IMPLND 14 IWATER SURO 16.325 COPY 20 INPUT MEAN 1
*****
*** Walker Creek Impervious Surface
*****
IMPLND 14 IWATER SURO 1.383 COPY 30 INPUT MEAN 1

```

implow

```
*****  
*** Miller Creek Impervious Surface  
*****  
IMPLND 14 IWATER SURO      2.191      COPY 40      INPUT MEAN 1  
*****  
END NETWORK  
  
END RUN
```

VOLUME 2

AR 020141

Low Streamflow Analysis and Summer Low Flow Impact Offset Facility Proposal



December 2001

Parametrix, Inc.

Volume 2

Appendix A

AR 020142

APPENDIX A

HSPF MODELING INFORMATION AND DATA

CONTENTS

- HSPF Model Low Flow Calibration Review
- Land Use Tables (Surface Water Subbasins, Contiguous Groundwater Subbasins, and Non-Contiguous Groundwater Subbasins) for Miller, Walker, and Des Moines Creek Watersheds
- HSPF Input Files (1994 and 2006 Conditions) for Miller, Walker, and Des Moines Creek Watersheds
- HSPF Non-Contiguous Groundwater Information

HSPF MODEL LOW FLOW CALIBRATION REVIEW

**SEATTLE-TACOMA INTERNATIONAL AIRPORT
MASTER PLAN UPDATE IMPROVEMENTS**

TABLE OF CONTENTS

	<u>Page</u>
1. INTRODUCTION	A-1
2. MILLER CREEK LOW STREAMFLOW	A-2
2.1 MILLER CREEK AT THE MOUTH.....	A-2
2.2 MILLER CREEK AT THE DETENTION FACILITY	A-10
3. WALKER CREEK LOW STREAMFLOW.....	A-18
3.1 WALKER CREEK AT THE MOUTH	A-18
3.2 WALKER CREEK NEAR THE WETLAND.....	A-23
4. DES MOINES CREEK LOW STREAMFLOW	A-32
4.1 DES MOINES CREEK AT THE MOUTH.....	A-32
4.2 DES MOINES CREEK AT GAGE 11C	A-38
5. SUMMARY	A-45

LIST OF FIGURES

<u>Figure</u>	<u>Page</u>
2-1 Miller Creek at the Mouth Observed vs. Calibrated Low Flow 1991.....	A-3
2-2 Miller Creek at the Mouth Observed vs. Calibrated Low Flow 1992.....	A-4
2-3 Miller Creek at the Mouth Observed vs. Calibrated Low Flow 1993.....	A-5
2-4 Miller Creek at the Mouth Observed vs. Calibrated Low Flow 1994.....	A-6
2-5 Miller Creek at the Mouth Observed vs. Calibrated Low Flow 1995.....	A-7
2-6 Miller Creek at the Mouth Observed vs. Calibrated Low Flow 1996.....	A-8
2-7 Miller Creek at the Miller Creek detention facility Observed vs. Calibrated Low Flow 1991.....	A-11
2-8 Miller Creek at the Miller Creek detention facility Observed vs. Calibrated Low Flow 1992.....	A-12
2-9 Miller Creek at the Miller Creek detention facility Observed vs. Calibrated Low Flow 1993.....	A-13
2-10 Miller Creek at the Miller Creek detention facility Observed vs. Calibrated Low Flow 1994.....	A-14
2-11 Miller Creek at the Miller Creek detention facility Observed vs. Calibrated Low Flow 1995.....	A-15
2-12 Miller Creek at the Miller Creek detention facility Observed vs. Calibrated Low Flow 1996.....	A-16
3-1 Walker Creek at the Mouth Observed vs. Calibrated Low Flow 1993.....	A-19
3-2 Walker Creek at the Mouth Observed vs. Calibrated Low Flow 1994.....	A-20
3-3 Walker Creek at the Mouth Observed vs. Calibrated Low Flow 1995.....	A-21
3-4 Walker Creek at the Mouth Observed vs. Calibrated Low Flow 1996.....	A-22
3-5 Walker Creek Near Wetland Observed vs. Calibrated Low Flow 1991.....	A-24
3-6 Walker Creek Near Wetland Observed vs. Calibrated Low Flow 1992.....	A-25
3-7 Walker Creek Near Wetland Observed vs. Calibrated Low Flow 1993.....	A-26
3-8 Walker Creek Near Wetland Observed vs. Calibrated Low Flow 1994.....	A-27
3-9 Walker Creek Near Wetland Observed vs. Calibrated Low Flow 1995.....	A-28
3-10 Walker Creek Near Wetland Observed vs. Calibrated Low Flow 1996.....	A-29
4-1 Des Moines Creek at the Mouth Observed vs. Calibrated Low Flow 1992.....	A-33
4-2 Des Moines Creek at the Mouth Observed vs. Calibrated Low Flow 1993.....	A-34
4-3 Des Moines Creek at the Mouth Observed vs. Calibrated Low Flow 1994.....	A-35
4-4 Des Moines Creek at the Mouth Observed vs. Calibrated Low Flow 1995.....	A-36
4-5 Des Moines Creek at the Mouth Observed vs. Calibrated Low Flow 1996.....	A-37
4-6 Des Moines Creek at Gage 11c Observed vs. Calibrated Low Flow 1991.....	A-39
4-7 Des Moines Creek at Gage 11c Observed vs. Calibrated Low Flow 1992.....	A-40
4-8 Des Moines Creek at Gage 11c Observed vs. Calibrated Low Flow 1993.....	A-41
4-9 Des Moines Creek at Gage 11c Observed vs. Calibrated Low Flow 1994.....	A-42
4-10 Des Moines Creek at Gage 11c Observed vs. Calibrated Low Flow 1995.....	A-43
4-11 Des Moines Creek at Gage 11c Observed vs. Calibrated Low Flow 1996.....	A-44

LIST OF TABLES

<u>Table</u>	<u>Page</u>
2-1	Miller Creek at the mouth, June through November low-flow average flows for water-years 1991 through 1996. A-9
2-2	Miller Creek at the mouth, 7-day low flows for water-years 1991 through 1996..... A-9
2-3	Miller Creek at the Miller Creek detention facility, June through November low-flow average flows for water-years 1991 through 1996. A-17
2-4	Miller Creek at the Miller Creek detention facility, 7-day low flows for water-years 1991 through 1996. A-17
3-1	Walker Creek at the mouth, June through November low-flow average flows for water-years 1993 through 1996. A-18
3-2	Walker Creek at the mouth, 7-day low flows for water-years 1993 through 1996..... A-18
3-3	Walker Creek near wetland, June through November low-flow average flows for water-years 1991 through 1996. A-23
3-4	Walker Creek near wetland, 7-day low flows for water-years 1991 through 1996. A-23
3-5	Walker Creek correlation of average annual gage flow at the mouth and near the wetland. A-30
3-6	Walker Creek correlation of 7-day low-flow gage flow at the mouth and near the wetland. A-31
4-1	Des Moines Creek at the mouth, June through November low-flow average flows for water-years 1992 through 1996. A-32
4-2	Des Moines Creek at the mouth, June through November 7-day low flows for water-years 1992 through 1996. A-38
4-3	Des Moines Creek low flow at the mouth, recorded July 15, 1992 base flow..... A-38
4-4	Des Moines Creek at gage 11c, June through November low-flow average flows for water-years 1991 through 1996. A-45
4-5	Des Moines Creek at gage 11c, June through November 7-day low flows for water-years 1991 through 1996. A-45

1. INTRODUCTION

The computer program HSPF was used to simulate continuous watershed hydrology and to design stormwater detention facilities for Port of Seattle's Master Plan Update at Seattle-Tacoma International Airport (STIA). The HSPF modeling and calibration are described in detail in the *Comprehensive Stormwater Management Plan (SMP)* (Parametrix, Inc. 2000, 2001). The overall HSPF model calibration effort did not specifically focus on the low-streamflow period, which is considered to be June through November. This appendix provides detailed information on the HSPF model calibration as related to the low-flow analysis for the Miller, Walker, and Des Moines Creek watersheds.

2. MILLER CREEK LOW STREAMFLOW

Two streamflow gages located in the Miller Creek watershed were used in the low-streamflow calibration review (see Figure 2-1 in the main text for gage locations). One of the streamflow gages was located near the mouth of Miller Creek, and the other was located further upstream at the Miller Creek detention facility. Data for the streamflow gages were collected by the King County Department of Natural Resources (DNR). The analysis period covers water-years 1991 through 1996. The modeling team selected this period because it appeared to contain the most reliable data. However, the observed data from these water-years contain several gaps. The dates of the missing data are listed in Table B2-1 (Appendix B, Volume 3 of the SMP).

2.1 MILLER CREEK AT THE MOUTH

The streamflow gage was down for 4 months during water-year 1995. Examination of the recorded data after a gage malfunction in December and January of water-year 1995 indicated possible disruption in the reliability of the recorded data for the months of January through May. In June of 1995, the gage again malfunctioned. This malfunction lasted until the middle of October 1995. These chronic problems during water-year 1995 call into question the overall reliability of the gaged streamflow data for this water-year.

Observed and calibrated low flows for the gage near the mouth of Miller Creek are shown in Figures 2-1 through 2-6. Average simulated and observed streamflows for each low-flow period are listed in Table 2-1. Average simulated and observed streamflows for each 7-day low-flow period are listed in Table 2-2. The 7-day low-flow period for each observed water-year did not occur during the same 7-day period as the simulated low-flow period. Water-years 1991, 1992, 1994, and 1995 all have gaps missing from the observed data. Water-year 1994 appears to have a shift in the rating curve. Close inspection of the month of September shows a dramatic shift in the observed base flow conditions. Between September 4th and September 11th, two flood events occurred. The base flow entering these events was about 1.4 cubic feet per second (cfs). After the events, the base flow increased to approximately 2.5 cfs and stayed at or near this level the rest of the low-flow period. The 7-day low flow for water-year 1994 concluded on September 3rd. This was the earliest 7-day low-flow period of the 6 years of data, with the exception of 1996. The low-flow analysis period ended September 30th, 1996. This abrupt jump in observed base flows was not matched by simulated base flows. The cause of the jump in base flow has not been determined, nor is it known if this impacted later water-years.

Figure 2-1. Miller Creek at the Mouth Observed vs. Calibrated Low Flow 1991

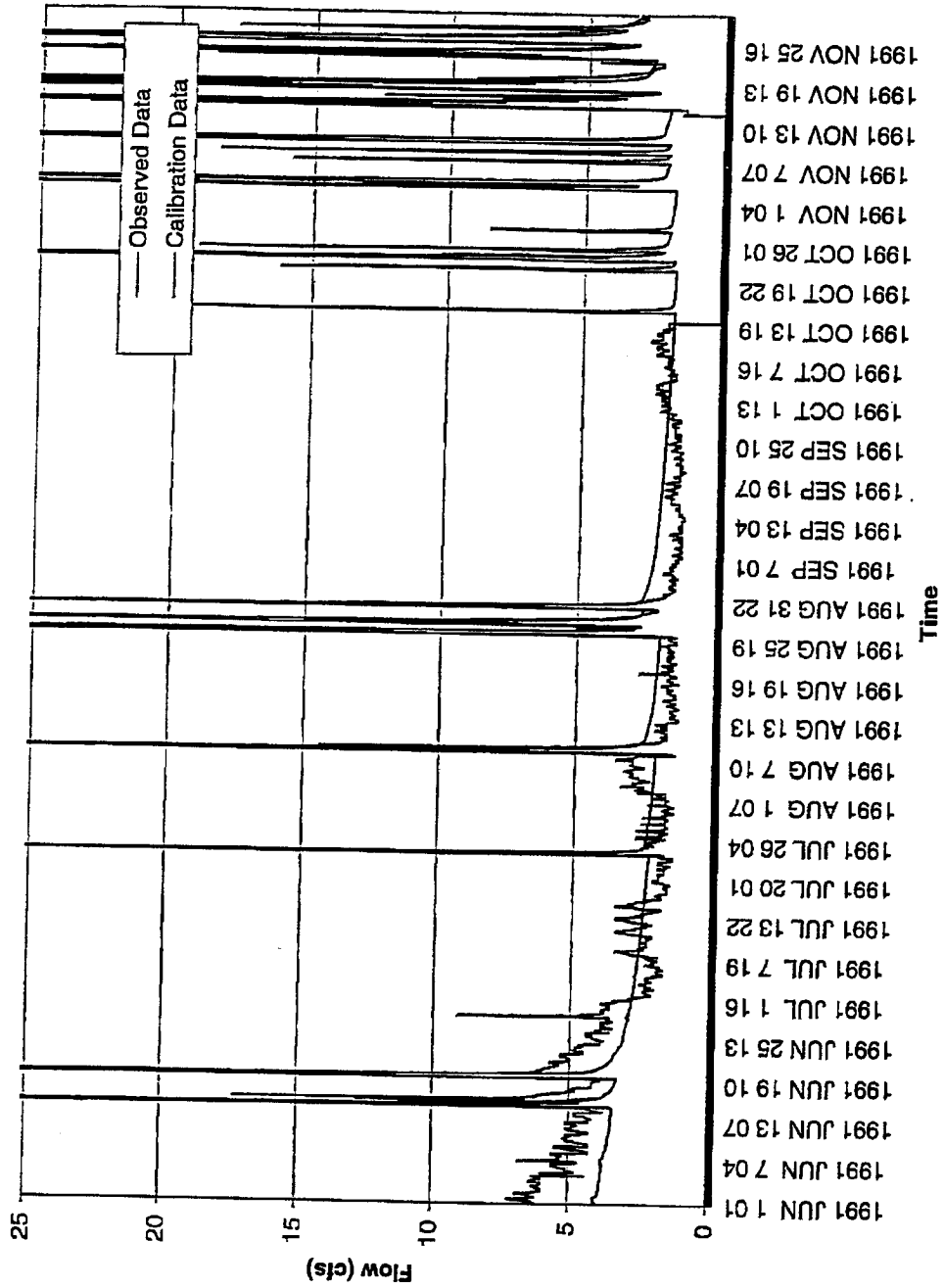

Figure 2-2. Miller Creek at the Mouth Observed vs. Calibrated Low Flow 1992

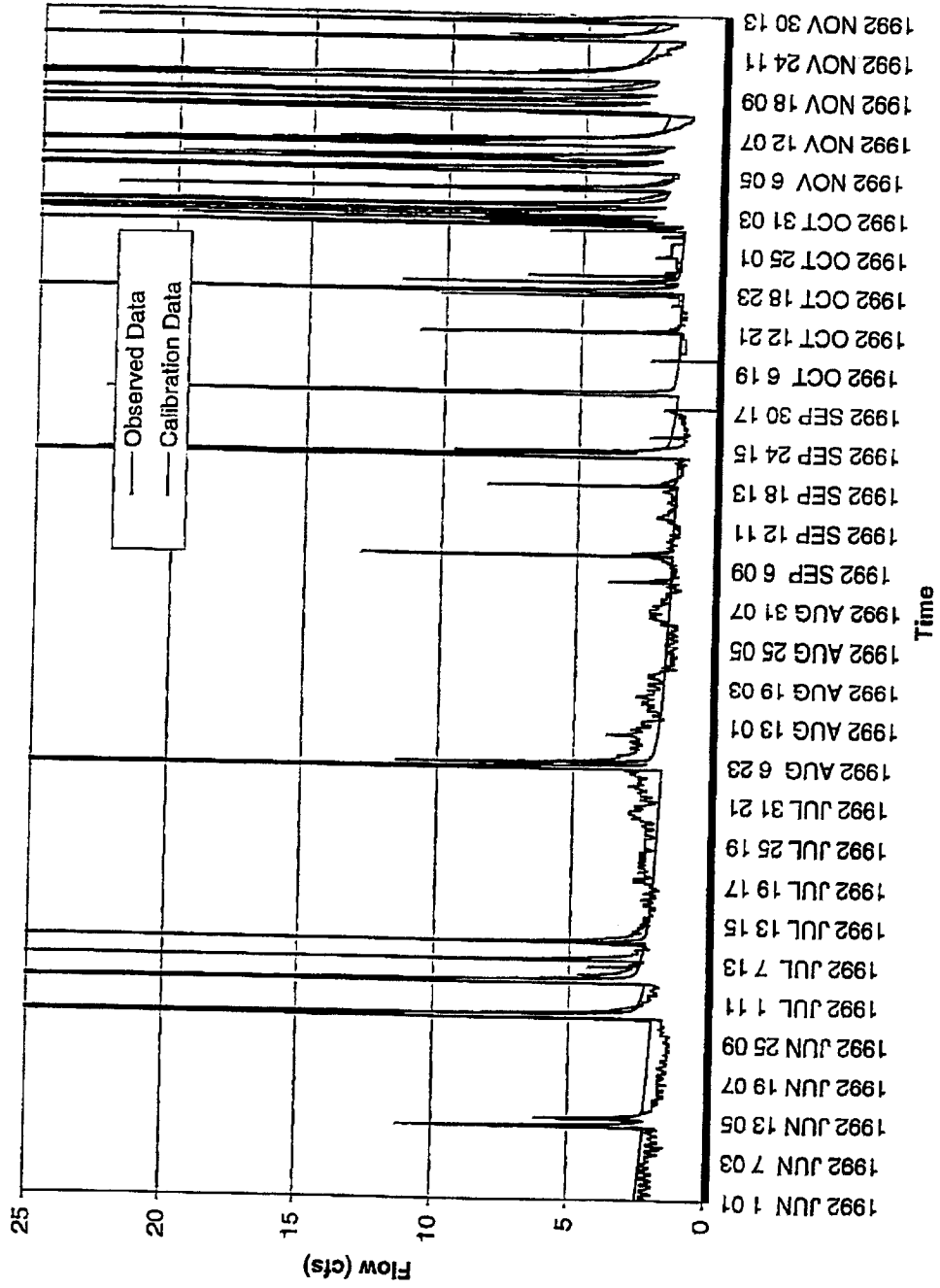

Figure 2-3. Miller Creek at the Mouth Observed vs. Calibrated Low Flow 1993

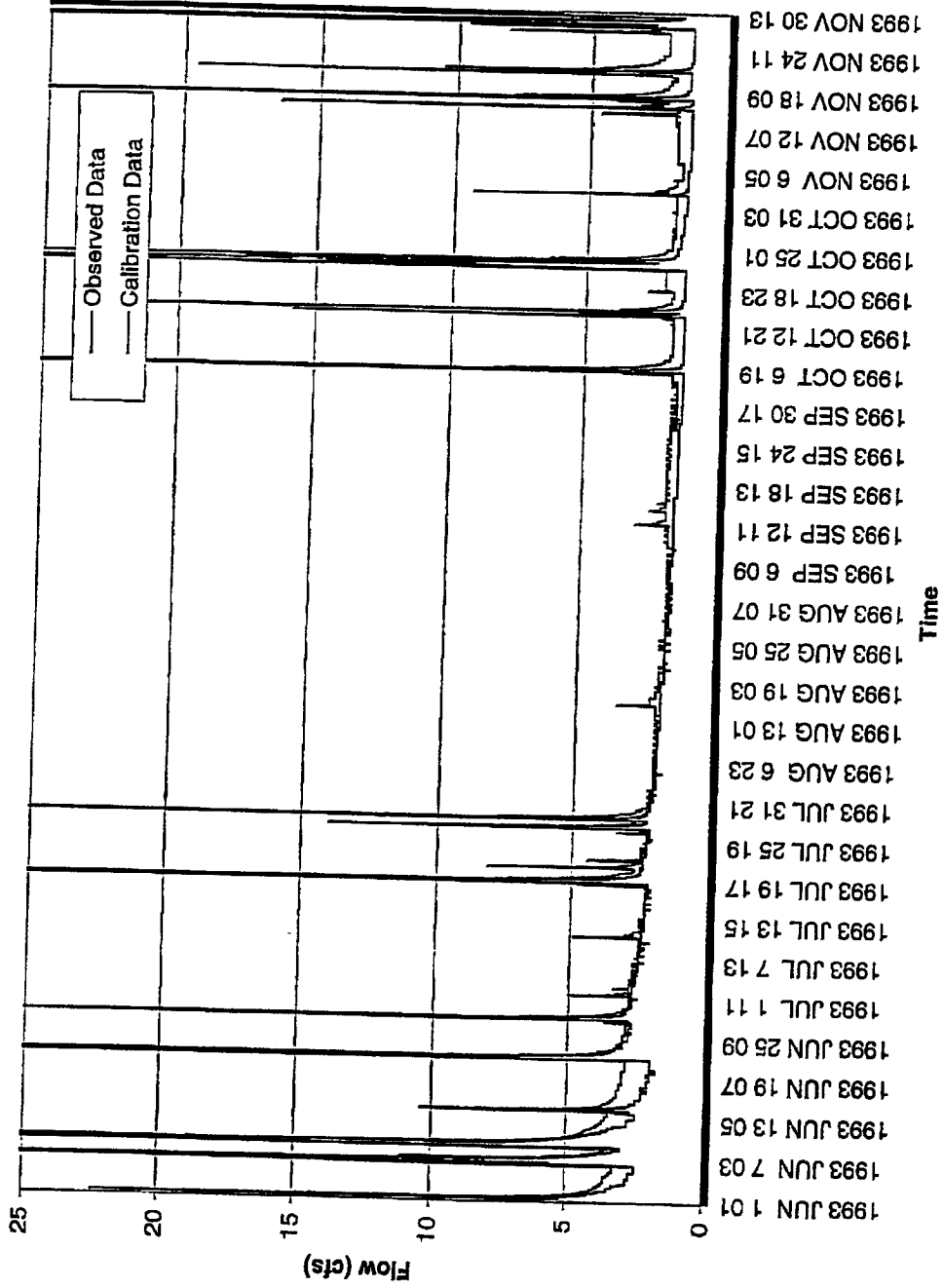
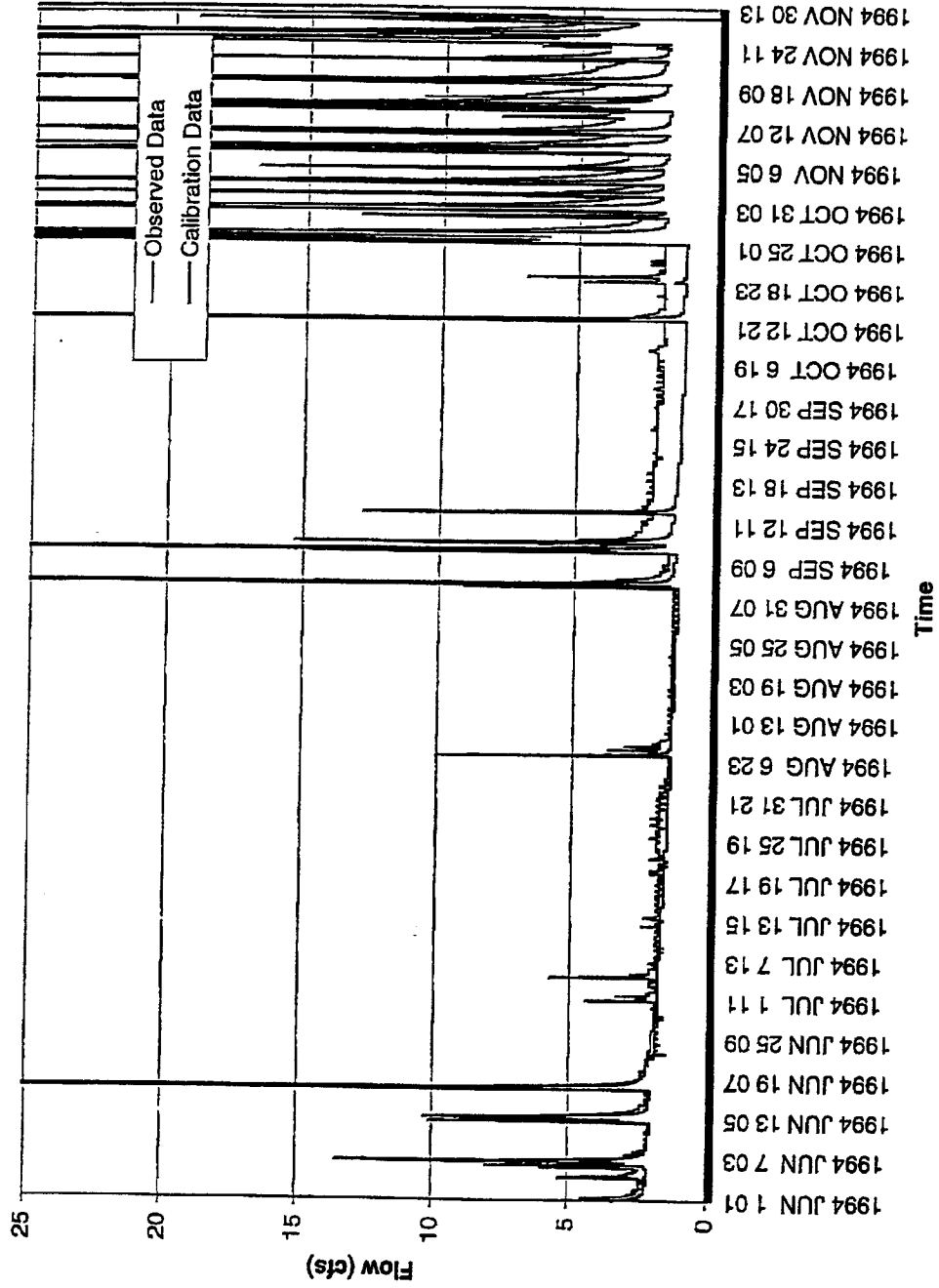
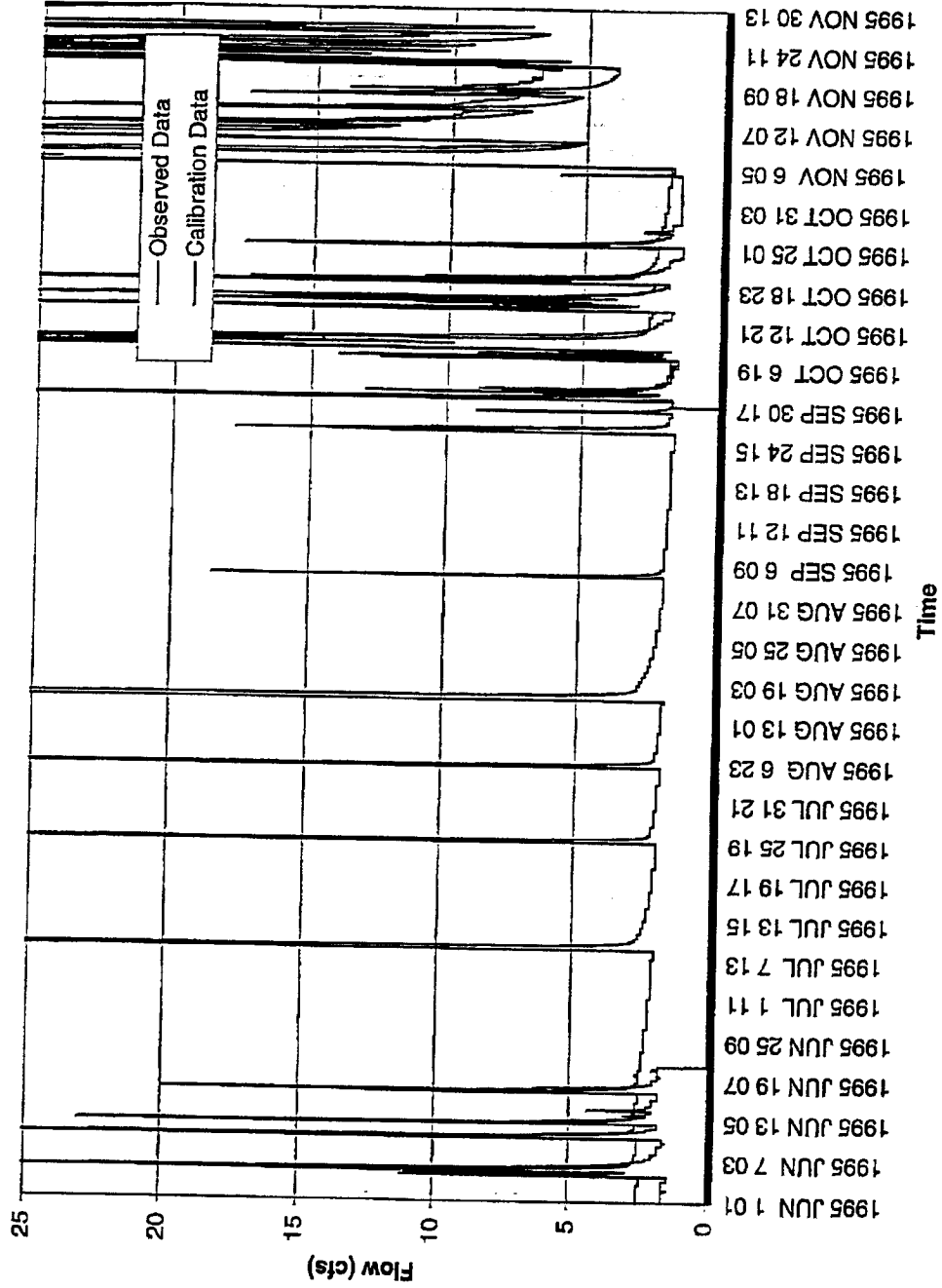

Figure 2-4. Miller Creek at the Mouth Observed vs. Calibrated Low Flow 1994



AR 020153

Figure 2-5. Miller Creek at the Mouth Observed vs. Calibrated Low Flow 1995



AR 020154

Figure 2-6. Miller Creek at the Mouth Observed vs. Calibrated Low Flow 1996

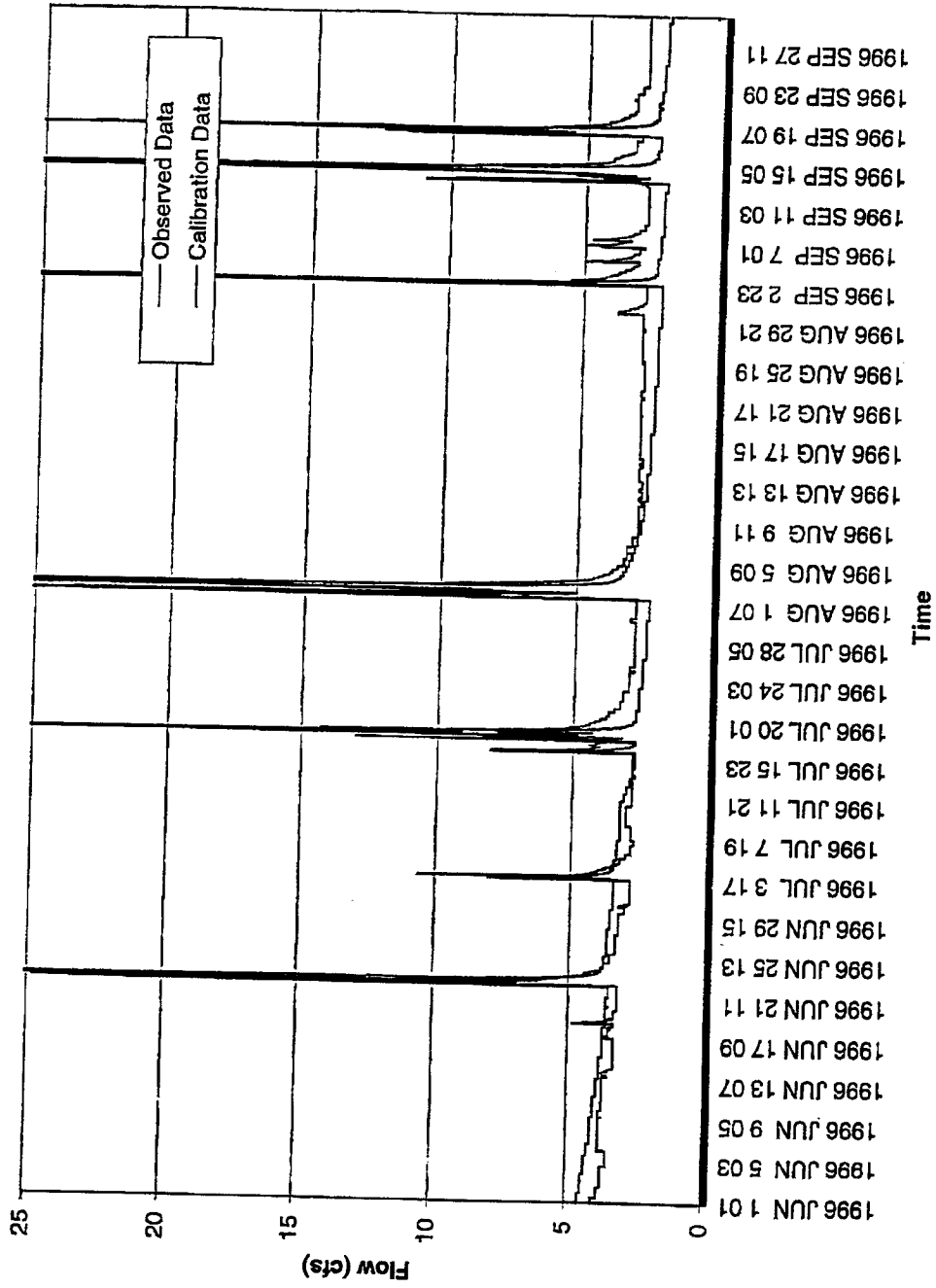

Table 2-1. Miller Creek at the mouth, June through November low-flow average flows for water-years 1991 through 1996.

Water-Year	Observed Average Flow (cfs)	Calibrated Average Flow (cfs)	Difference (cfs)
1991	3.429	3.756	-0.327
1992	3.034	3.387	-0.354
1993	2.914	2.792	0.122
1994	3.865	3.001	0.864
1995	10.433	9.775	0.658
1996	3.607	3.537	0.070
Average Difference	6.820	6.562	0.258

Table 2-2. Miller Creek at the mouth, 7-day low flows for water-years 1991 through 1996.

Water-Year	Observed Average Flow (cfs)	Calibrated Average Flow (cfs)	Difference (cfs)
1991	1.348	1.749	-0.401
1992	1.457	1.390	0.067
1993	1.639	1.300	0.339
1994	1.361	1.100	0.261
1995	1.500	1.661	-0.161
1996	2.762	2.138	0.624
Average Difference	2.517	2.335	0.182

2.2 MILLER CREEK AT THE DETENTION FACILITY

Observed and calibrated low flows at the Miller Creek detention facility are shown in Figures 2-7 through 2-12. Average simulated and observed streamflows for each low-flow period are listed in Table 2-3. Average simulated and observed streamflows for each 7-day low-flow period are listed in Table 2-4. The 7-day low-flow period for each observed water-year did not occur during the same 7-day period as the simulated low-flow period. Water-years 1993 and 1994 have gaps missing from the observed data, and in 1994, it is difficult to determine when there is a gage malfunction and when the stream goes dry.

In June 1991, the observed base flow suddenly dropped from about 2.5 cfs to 0.8 cfs. This is probably due to a change in the gage or the rating curve. At the end of September 1992, the gage malfunctioned. Prior to the malfunction, the observed base flow was about 1 cfs; after the gage was repaired, the base flow was about 0.1 cfs. This change in the basic behavior of the observed base flow is not matched by the simulated streamflow. For these reasons, water-years 1991 and 1992 were not used to determine the accuracy of the simulated low-flow data. Following this period, the simulated average streamflows are within 0.25 cfs of the observed average streamflows and the simulated 7-day low flows are within 0.09 cfs of the observed 7-day low flows. The general shape and magnitude of the simulated low flows is slightly lower than that of the observed low flows. This is due to the simulated routing of groundwater from some subbasins upstream of the Miller Creek detention facility. In an effort to match overall volumes at the Miller Creek detention facility, some of the groundwater upstream of the Miller Creek detention facility was routed to the Vacca Farm area. While this assumption improved the accuracy of the overall HSPF modeling, it is possible that some of this groundwater does in fact contribute to streamflow at the Miller Creek detention facility. This is not an issue for this analysis since the point of compliance for the low-flow study is downstream of Vacca Farm (therefore, all of the contributing groundwater was included).

Figure 2-7. Miller Creek at the Miller Creek Detention Facility Observed vs. Calibrated Low Flow 1991

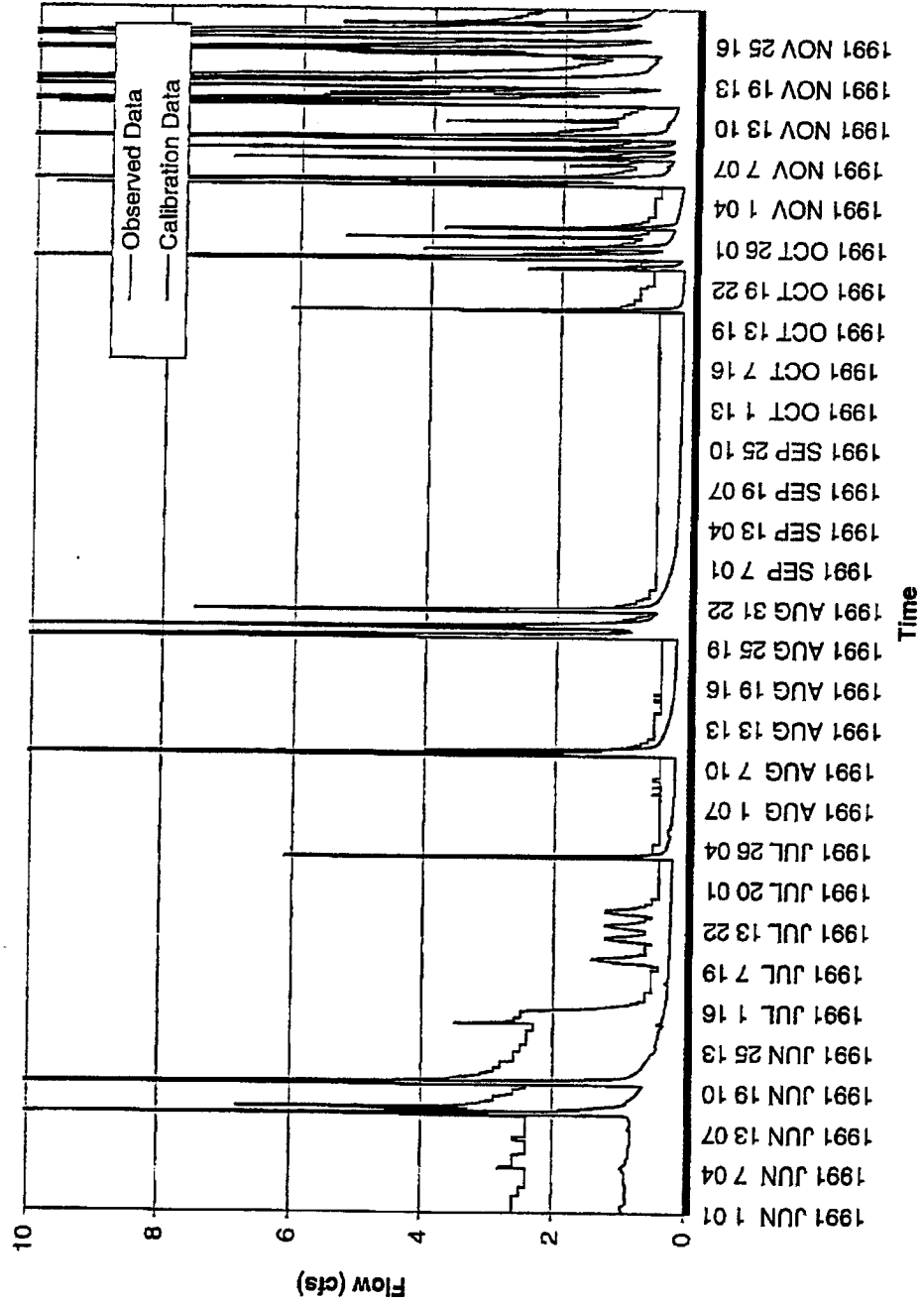

Figure 2-8. Miller Creek at the Miller Creek Detention Facility Observed vs. Calibrated Low Flow 1992

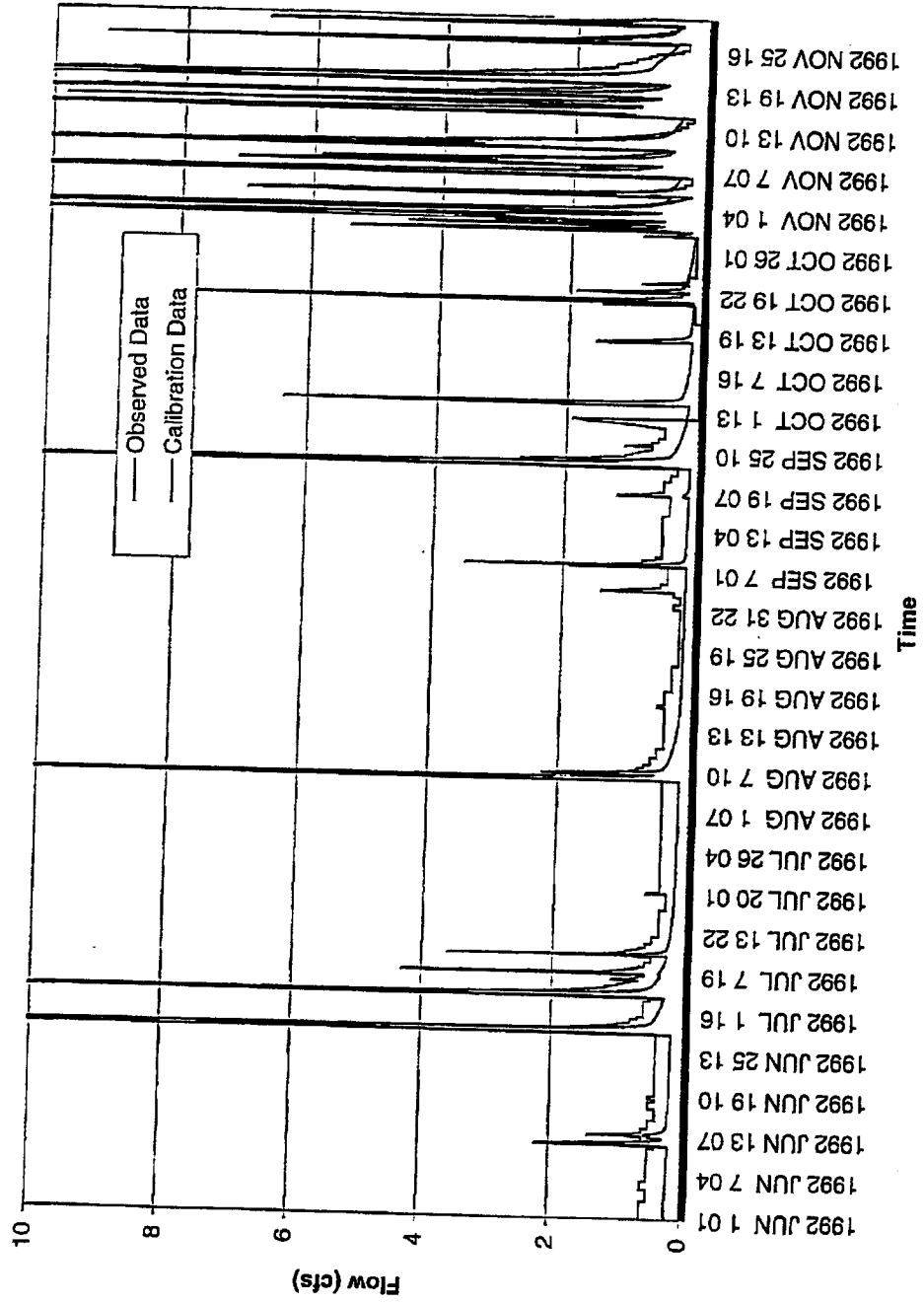
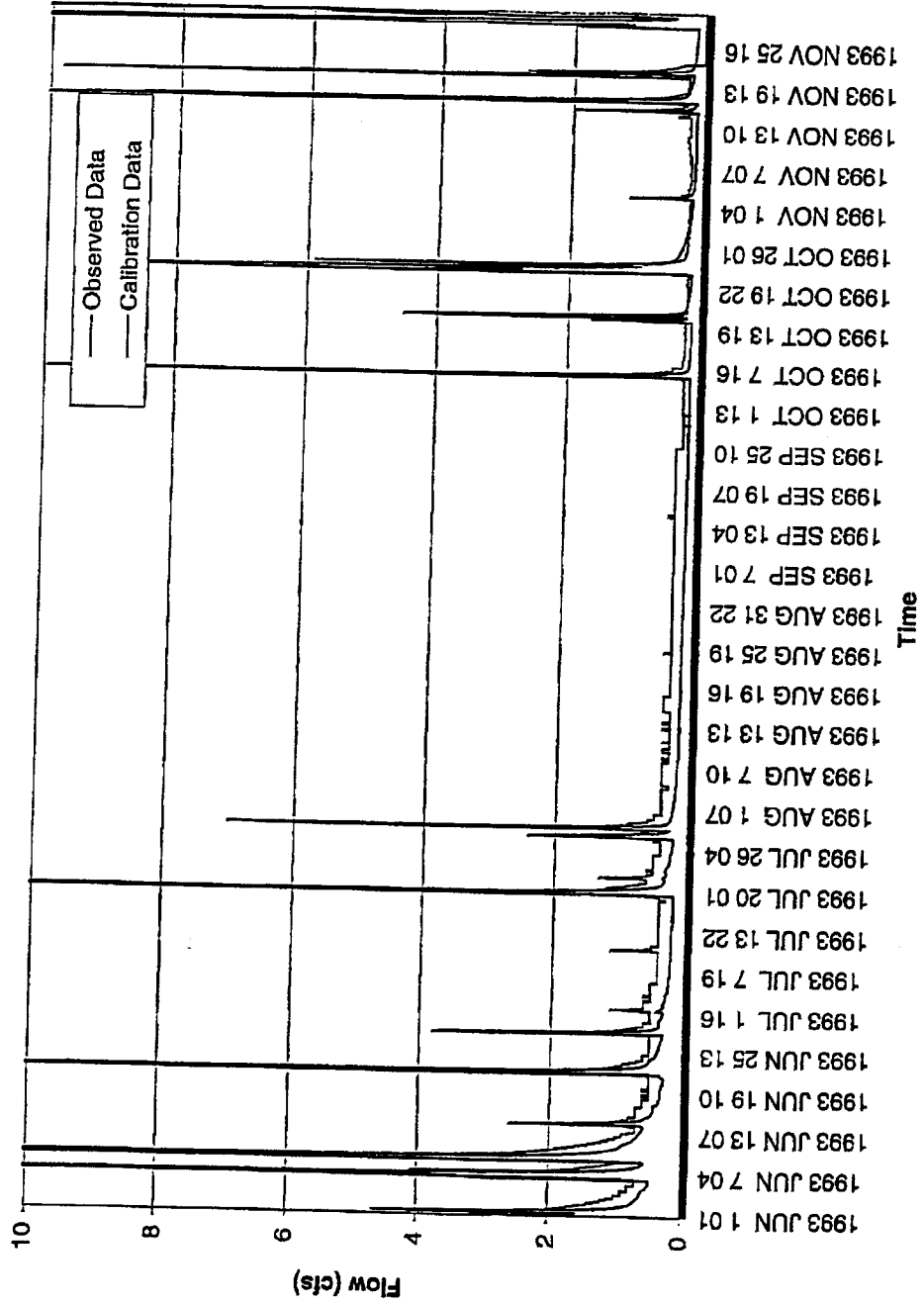

Figure 2-9. Miller Creek at the Miller Creek Detention Facility Observed vs. Calibrated Low Flow 1993



AR 020160

Figure 2-10. Miller Creek at the Miller Creek Detention Facility Observed vs. Calibrated Low Flow 1994

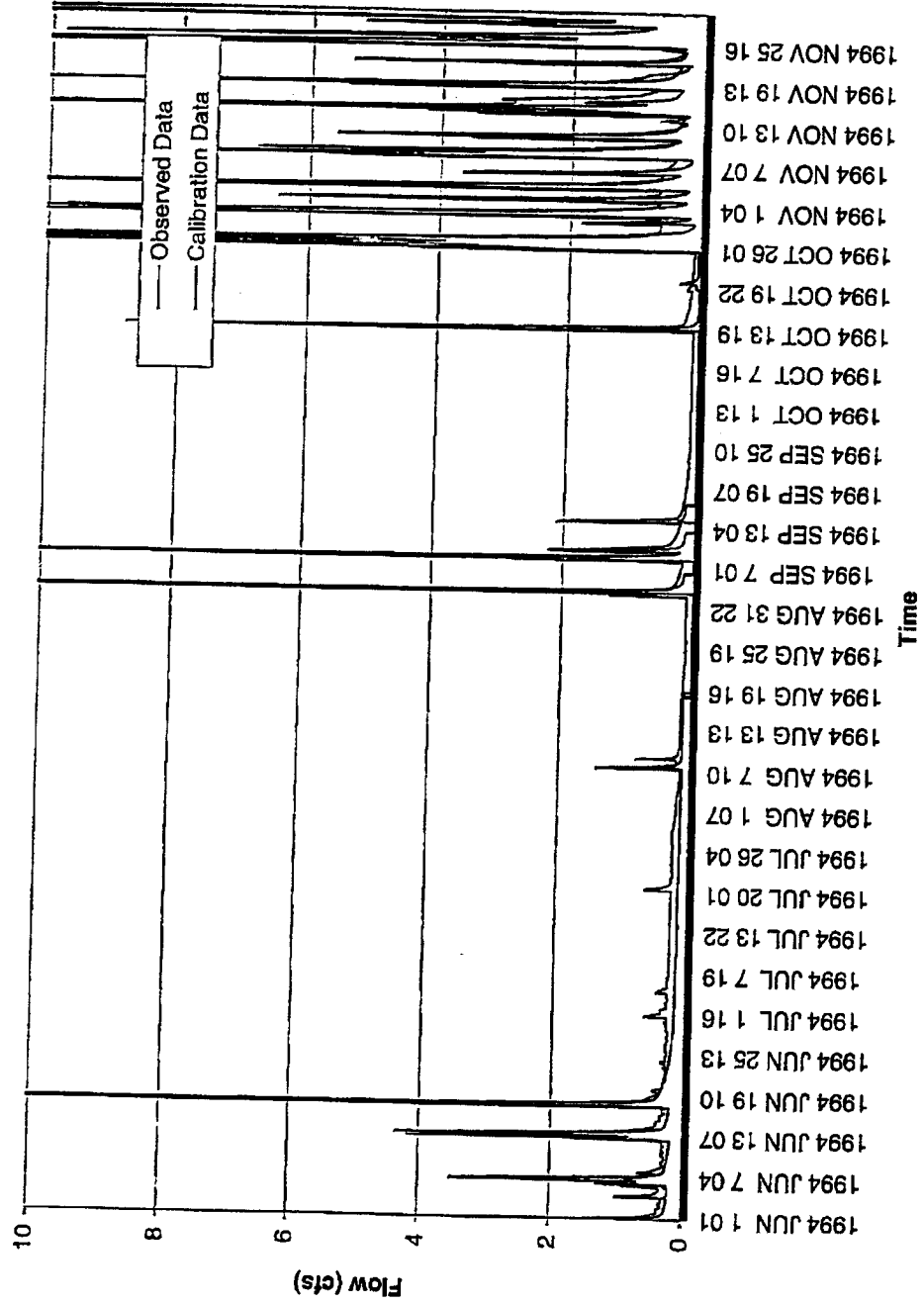

Figure 2-11. Miller Creek at the Miller Creek Detention Facility Observed vs. Calibrated Low Flow 1995

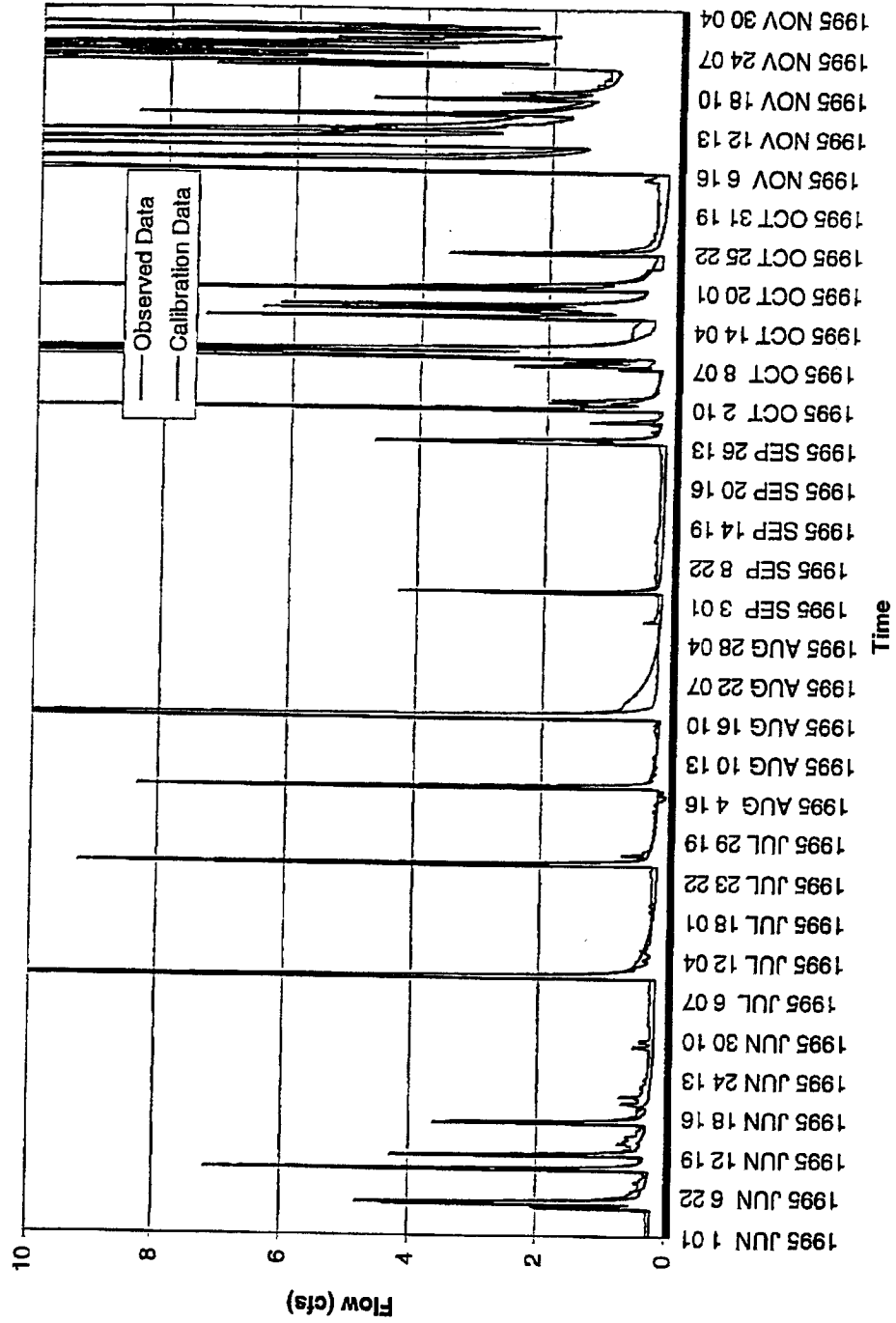

Figure 2-12. Miller Creek at the Miller Creek Detention Facility Observed vs. Calibrated Low Flow 1996

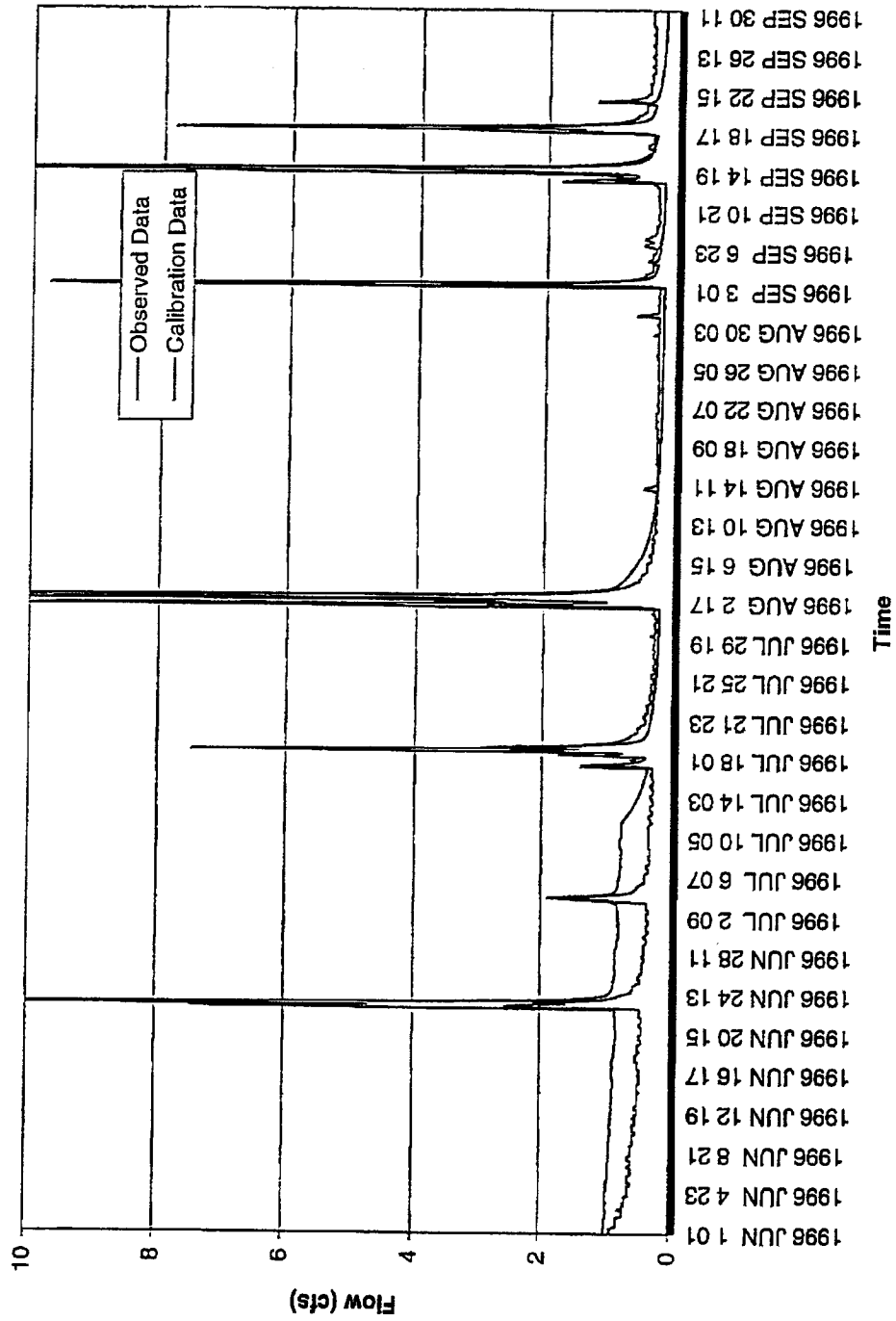

Table 2-3. Miller Creek at the Miller Creek detention facility, June through November low-flow average flows for water-years 1991 through 1996.

Water-Year	Observed Average Flow (cfs)	Calibrated Average Flow (cfs)	Difference (cfs)
1991	1.556	0.887	0.670
1992	0.860	0.873	-0.013
1993	0.577	0.467	0.109
1994	0.900	1.132	-0.232
1995	1.598	1.813	-0.215
1996	0.522	0.753	-0.231
Average Difference	1.503	1.481	0.022

Table 2-4. Miller Creek at the Miller Creek detention facility, 7-day low flows for water-years 1991 through 1996.

Water-Year	Observed Average Flow (cfs)	Calibrated Average Flow (cfs)	Difference (cfs)
1991	0.400	0.150	0.250
1992	0.127	0.124	0.004
1993	0.190	0.110	0.080
1994	0.000	0.090	-0.090
1995	0.183	0.137	0.045
1996	0.263	0.189	0.074
Average Difference	0.291	0.200	0.091

3. WALKER CREEK LOW STREAMFLOW

Two streamflow gages located in the Walker Creek watershed were used in the low-streamflow calibration review (see Figure 2-1 in the main text for gage locations). One of the streamflow gages was located near the mouth of Walker Creek, and the other was located further upstream near a wetland. Data for the streamflow gages were collected by King County DNR. The analysis period covers water-years 1993 through 1996. The modeling team selected this period because it appeared to contain the most reliable data. However, the observed data from these water-years still contain several gaps. The dates of the missing data are listed in Table B2-2 (Appendix B, Volume 3 of the SMP).

3.1 WALKER CREEK AT THE MOUTH

Observed and calibrated low flows for Walker Creek at the mouth are shown in Figures 3-1 through 3-4. Average simulated and observed streamflows for each low-flow period are listed in Table 3-1. Average simulated and observed streamflows for each 7-day low-flow period are listed in Table 3-2. The 7-day low-flow period for each observed water-year did not occur during the same 7-day period as the simulated low-flow period. Water-years 1994 and 1996 have gaps missing from the observed data, and water-year 1995 has some odd behavior in the months of August through October. The observed base flow on August 16th was 1.4 cfs. On August 17th, a flood event occurred with a maximum flow of 22.5 cfs. On August 18th, the event ended and flows dropped back down to base flows. However, the new base flow was 0.9 cfs, which was a drop of 0.5 cfs relative to the previous base flow. The base flow remained relatively flat until a flood event occurred on October 9th. When this event was over, the base flow jumped up to 1.9 cfs. The sharp decrease and subsequent increase in base flow was not matched by simulated data. The cause of these changes is not known.

Table 3-1. Walker Creek at the mouth, June through November low-flow average flows for water-years 1993 through 1996.

Water-Year	Observed Average Flow (cfs)	Calibrated Average Flow (cfs)	Difference (cfs)
1993	1.879	1.442	0.437
1994	1.584	1.283	0.301
1995	2.318	1.937	0.380
1996	2.034	1.723	0.310
Average Difference	1.953	1.596	0.357

Table 3-2. Walker Creek at the mouth, 7-day low flows for water-years 1993 through 1996.

Water-Year	Observed Average Flow (cfs)	Calibrated Average Flow (cfs)	Difference (cfs)
1993	1.502	0.923	0.579
1994	0.987	0.833	0.154
1995	0.915	1.077	-0.163
1996	1.719	1.287	0.432
Average Difference	1.281	1.030	0.250

Figure 3-1. Walker Creek at the Mouth Observed vs. Calibrated Low Flow 1993

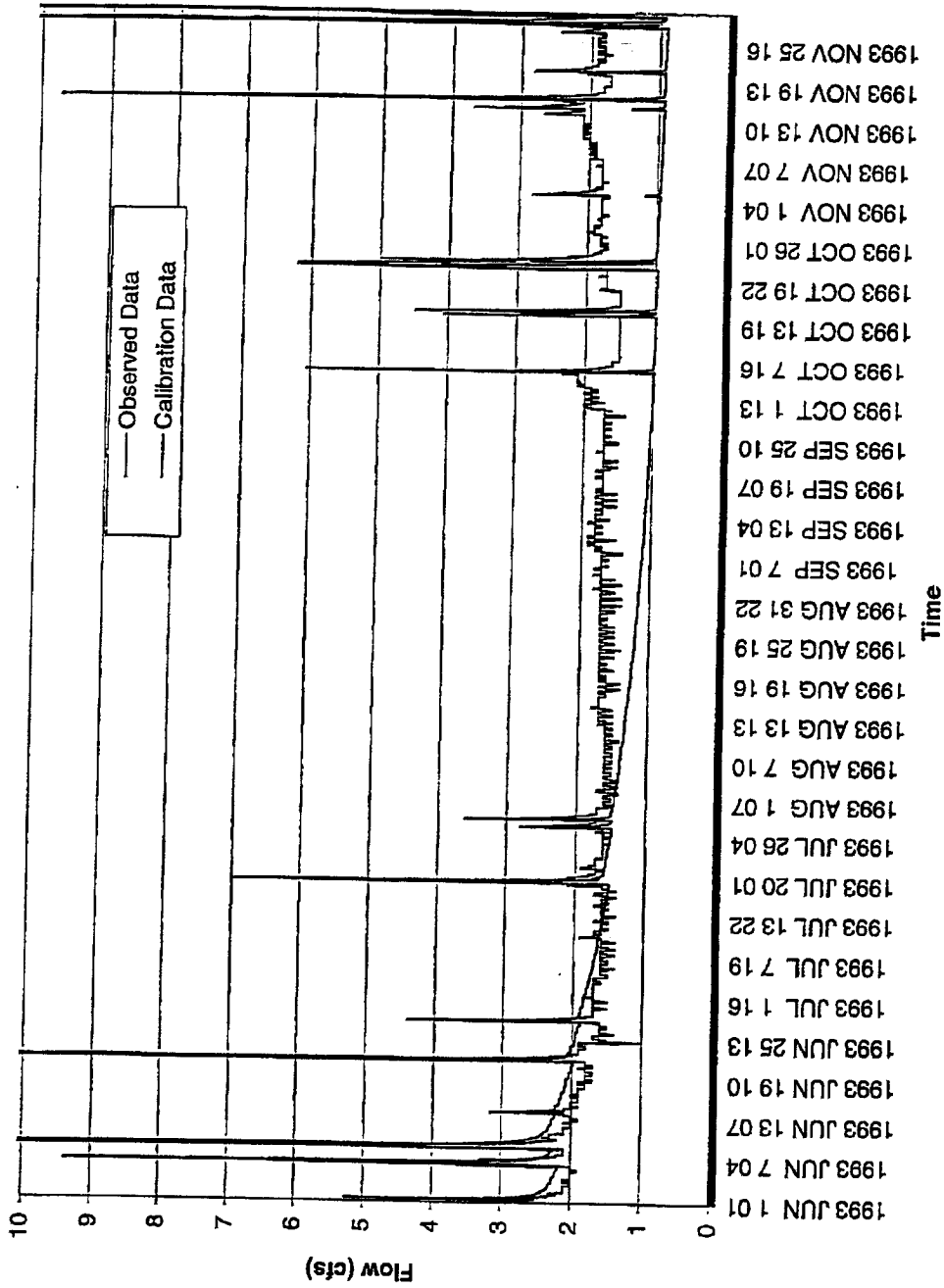

Figure 3-2. Walker Creek at the Mouth Observed vs. Calibrated Low Flow 1994

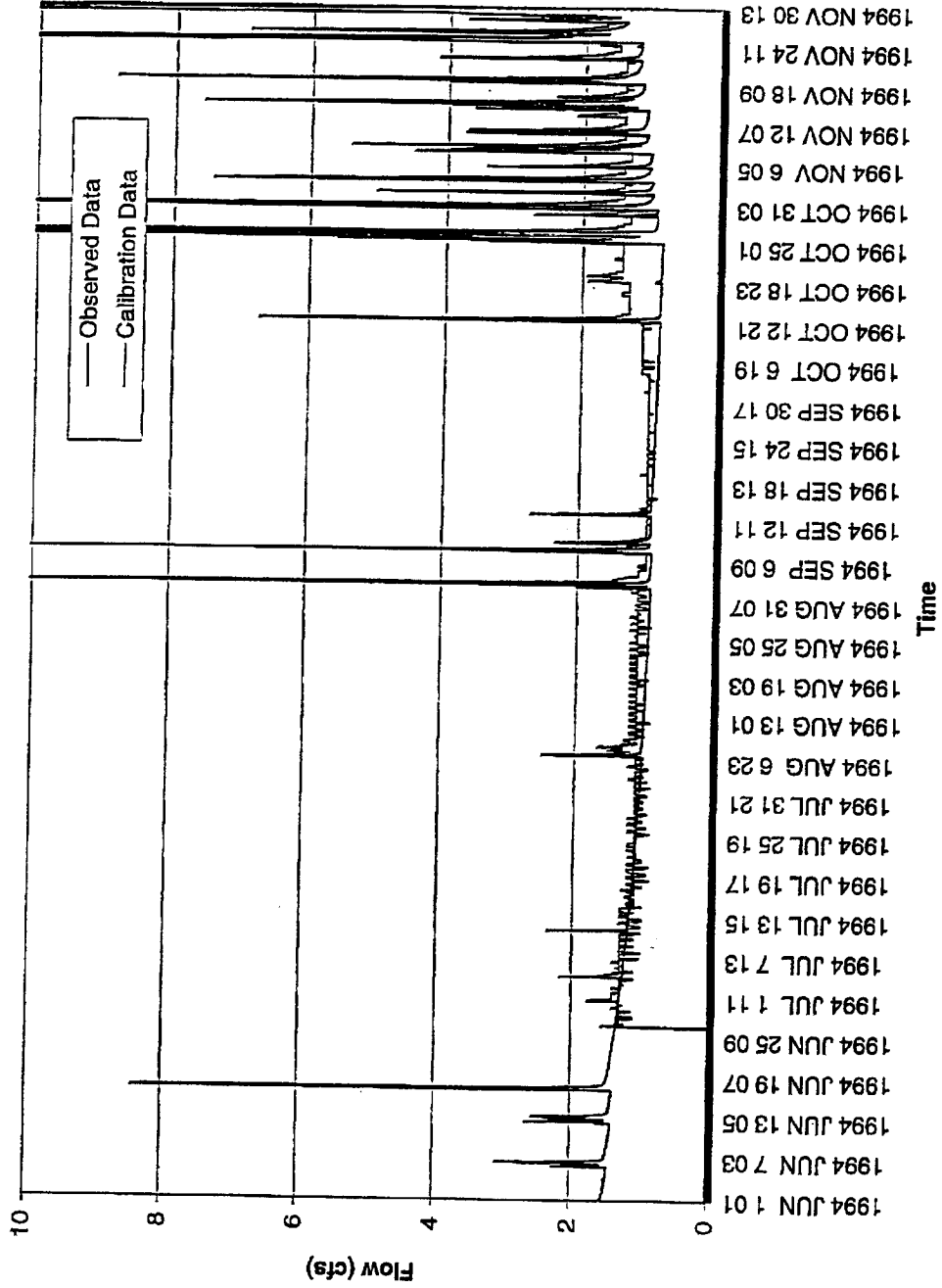

Figure 3-3. Walker Creek at the Mouth Observed vs. Calibrated Low Flow 1995

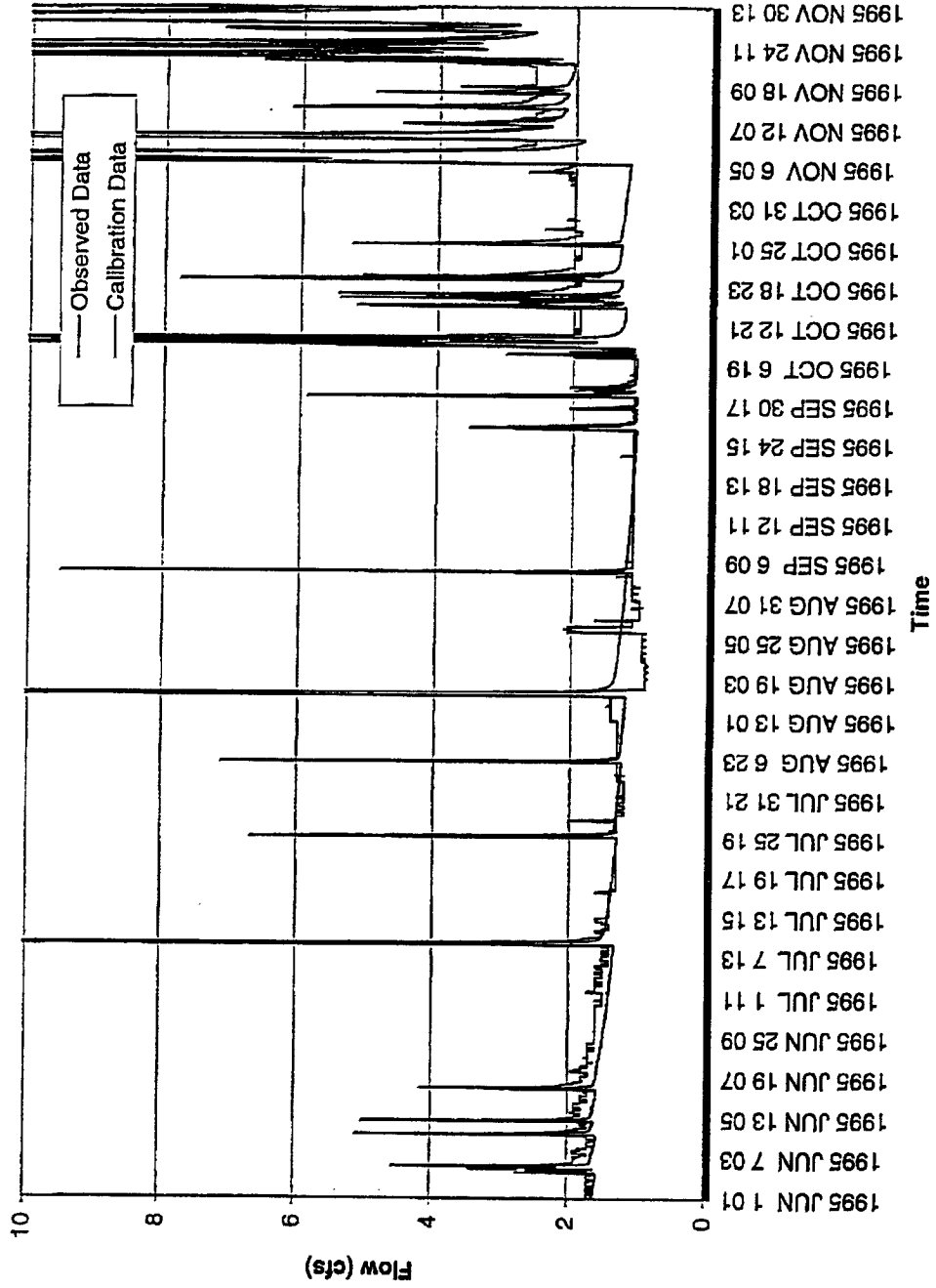
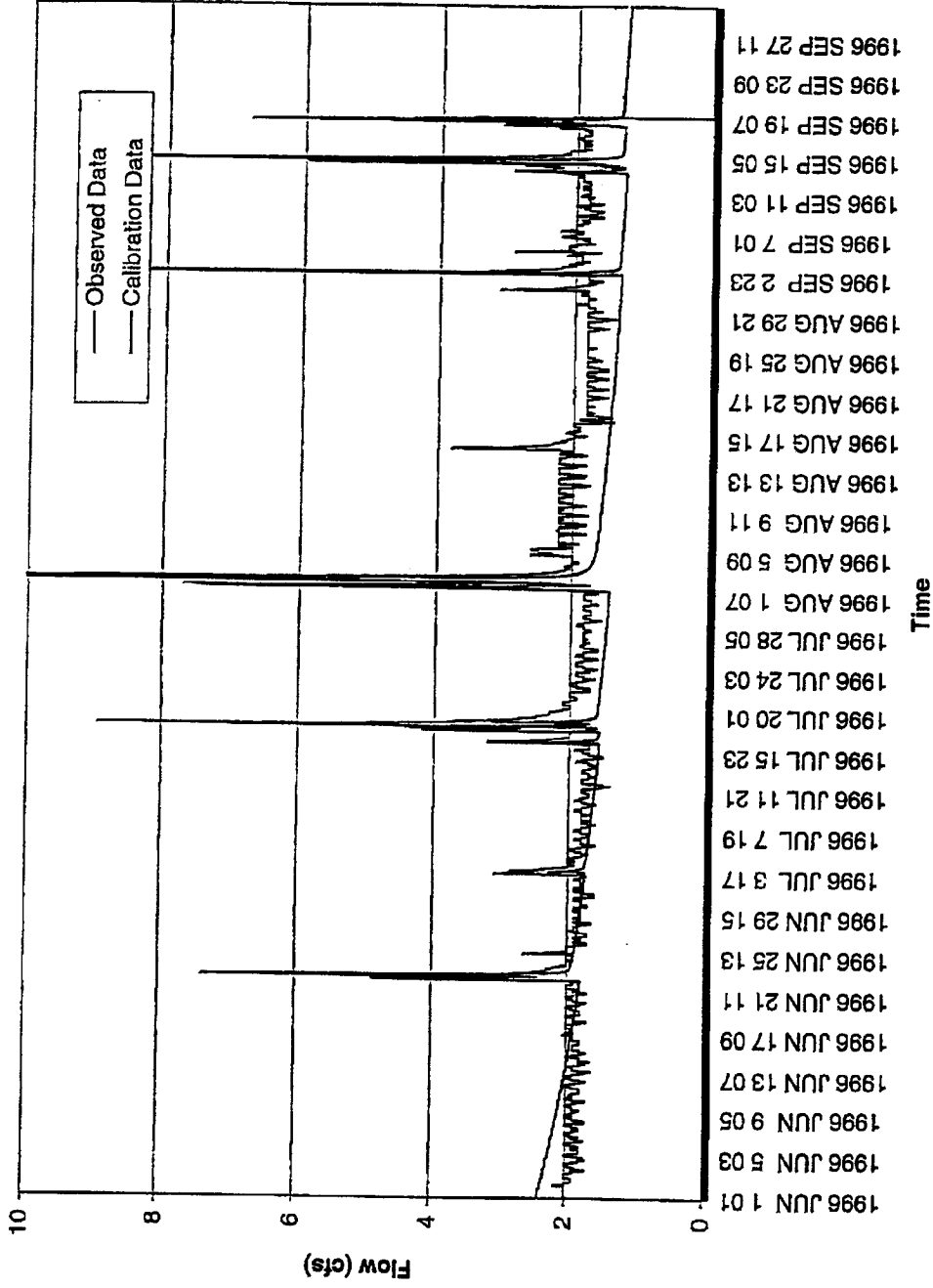

Figure 3-4. Walker Creek at the Mouth Observed vs. Calibrated Low Flow 1996



3.2 WALKER CREEK NEAR THE WETLAND

Observed and calibrated low flows for Walker Creek near the wetland are shown in Figures 3-5 through 3-10. Average simulated and observed streamflows for each low-flow period are listed in Table 3-3. Average simulated and observed streamflows for each 7-day low-flow period are listed in Table 3-4. The 7-day low-flow period for each observed water-year did not occur during the same 7-day period as the simulated low-flow period. Water-year 1994 had a small gap missing from the observed data.

Table 3-3. Walker Creek near wetland, June through November low-flow average flows for water-years 1991 through 1996.

Water-Year	Observed Average Flow (cfs)	Calibrated Average Flow (cfs)	Difference (cfs)
1991	1.667	1.065	0.601
1992	1.458	0.956	0.502
1993	1.189	0.978	0.210
1994	1.203	0.898	0.306
1995	1.103	1.232	-0.129
1996	1.515	1.113	0.402
Average Difference	1.252	1.055	0.197

Table 3-4. Walker Creek near wetland, 7-day low flows for water-years 1991 through 1996.

Water-Year	Observed Average Flow (cfs)	Calibrated Average Flow (cfs)	Difference (cfs)
1991	1.208	0.786	0.422
1992	1.098	0.682	0.416
1993	0.800	0.666	0.134
1994	0.670	0.614	0.056
1995	0.256	0.750	-0.494
1996	0.896	0.870	0.026
Average Difference	0.656	0.725	-0.069

The 1995 low-flow period is not consistent with the other years. The 7-day observed low flow for this year was 0.25 cfs, compared to the simulated low flow of 0.75 cfs. The cause of this difference is unknown. However, this is the only year in which the simulated low flow was higher than the observed low flow. Furthermore, 7-day observed low flows at the mouth for years 1994 and 1995 were nearly identical (0.987 cfs and 0.915 cfs). The primary source of base flow for the Walker Creek watershed is the off-site groundwater area, which is routed into the wetland and is therefore upstream of both gage sites. Base flow at the wetland contributed on average 65 percent of all base flow at the mouth. A correlation between the gage near the wetland and the gage at the mouth helped determine the accuracy of this information. Average flows for both gage sites are listed in Tables 3-5 and 3-6. The year with the highest average annual flow at the mouth was 1995, and the year with the lowest average annual flow at the mouth was 1994. The year with the highest average

Figure 3-5. Walker Creek Near Wetland Observed vs. Calibrated Low Flow 1991

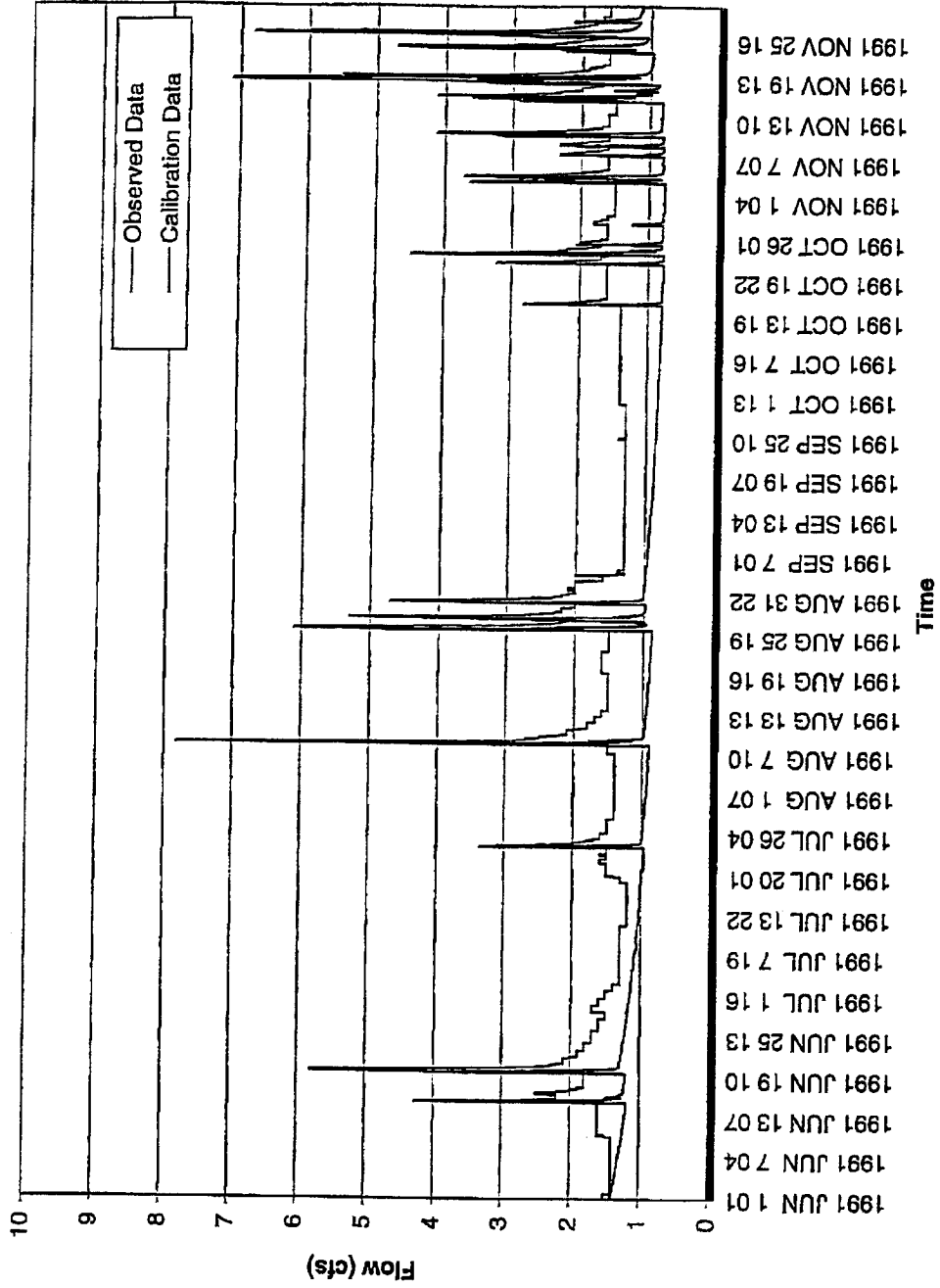

Figure 3-6. Walker Creek Near Wetland Observed vs. Calibrated Low Flow 1992

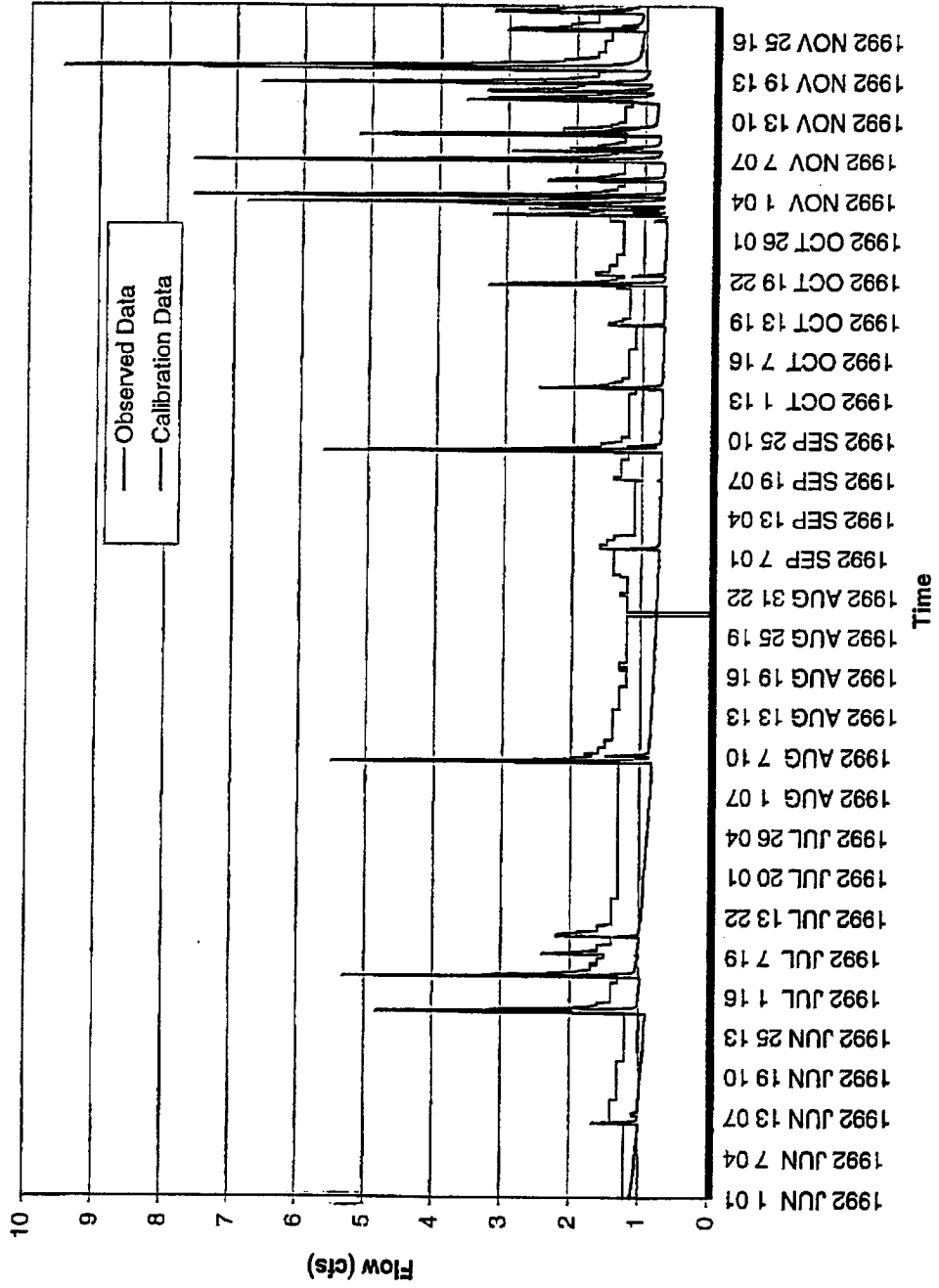

Figure 3-7. Walker Creek Near Wetland Observed vs. Calibrated Low Flow 1993

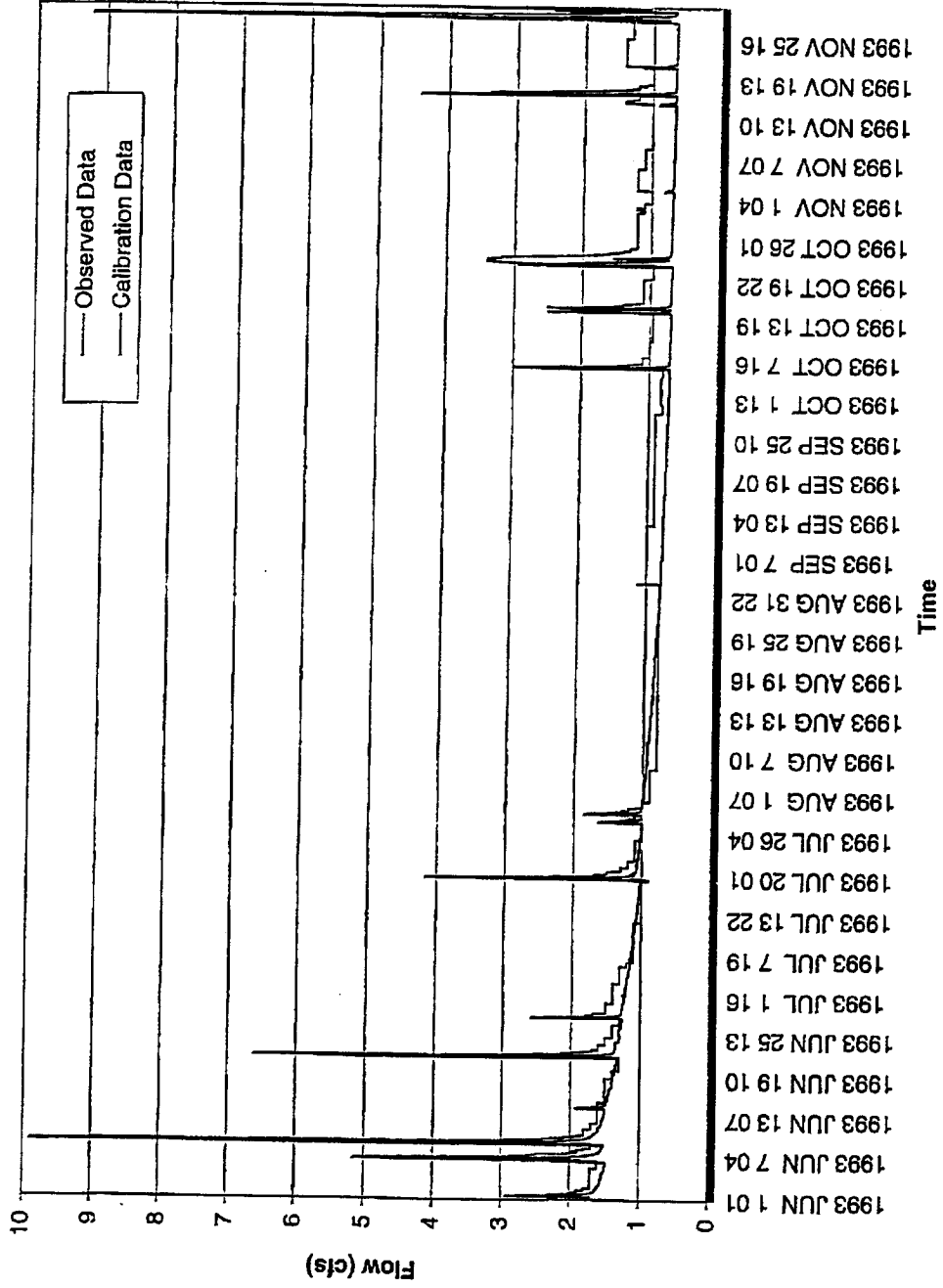
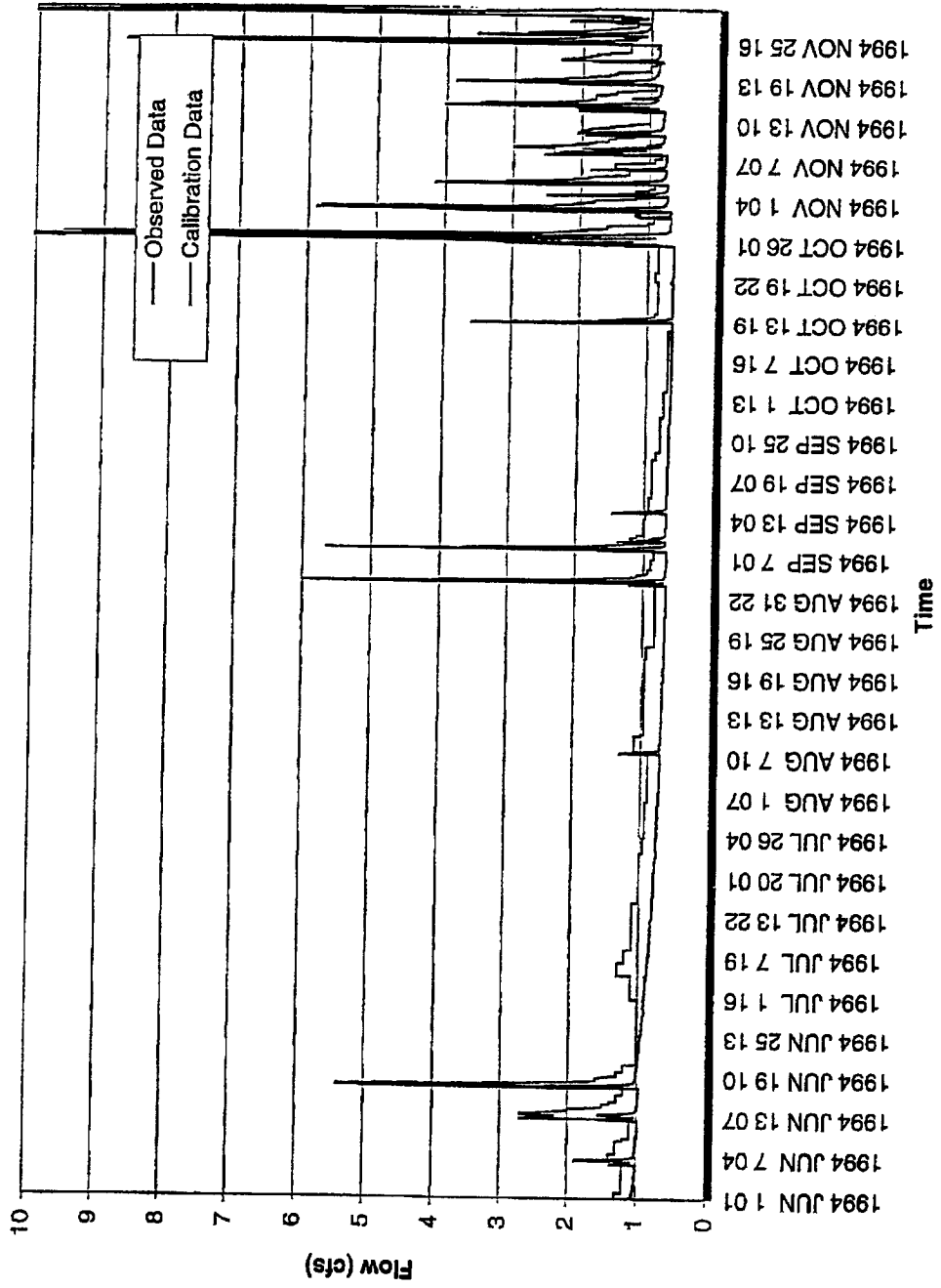

Figure 3-8. Walker Creek Near Wetland Observed vs. Calibrated Low Flow 1994



AR 020174

Figure 3-9. Walker Creek Near Wetland Observed vs. Calibrated Low Flow 1995

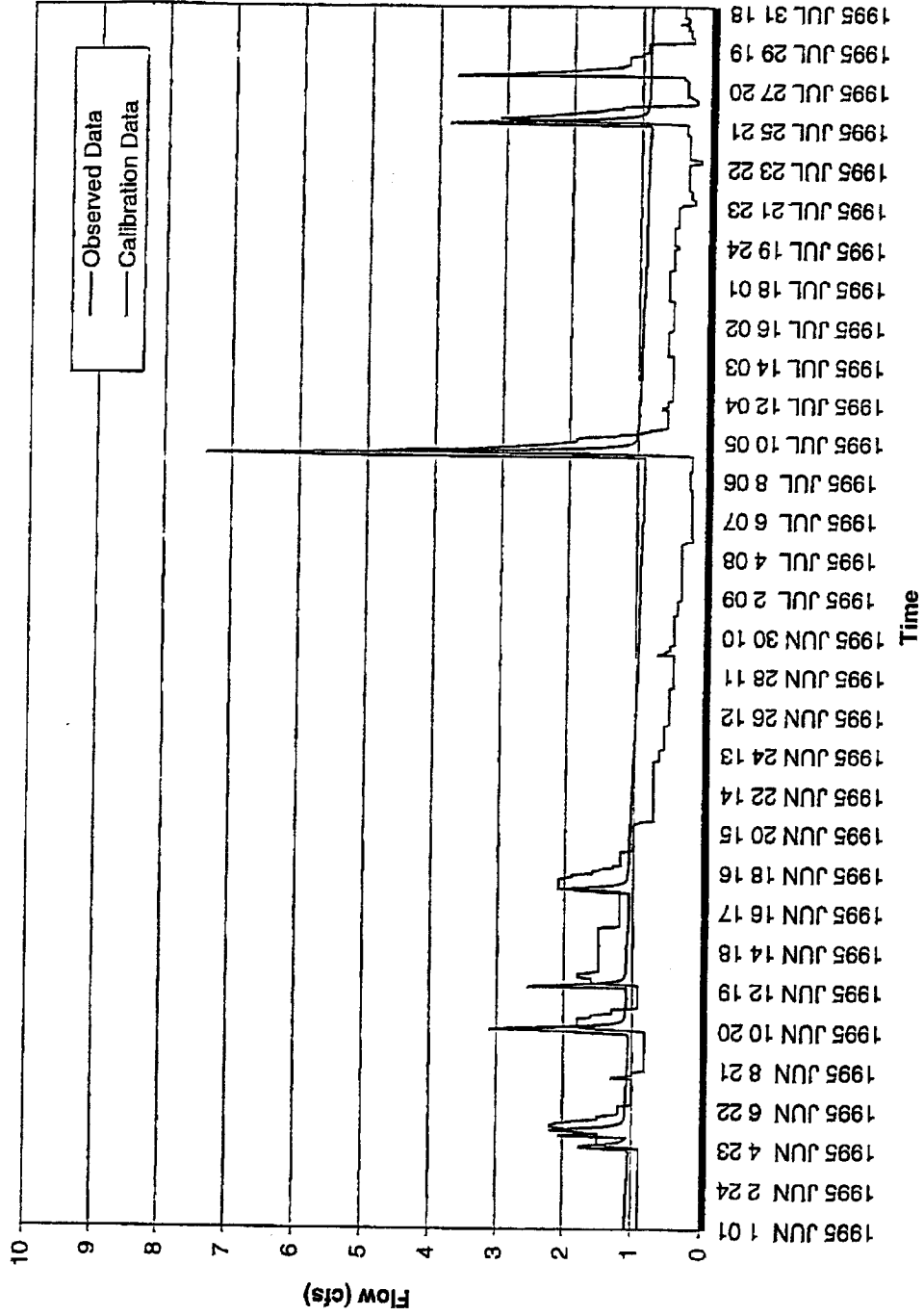
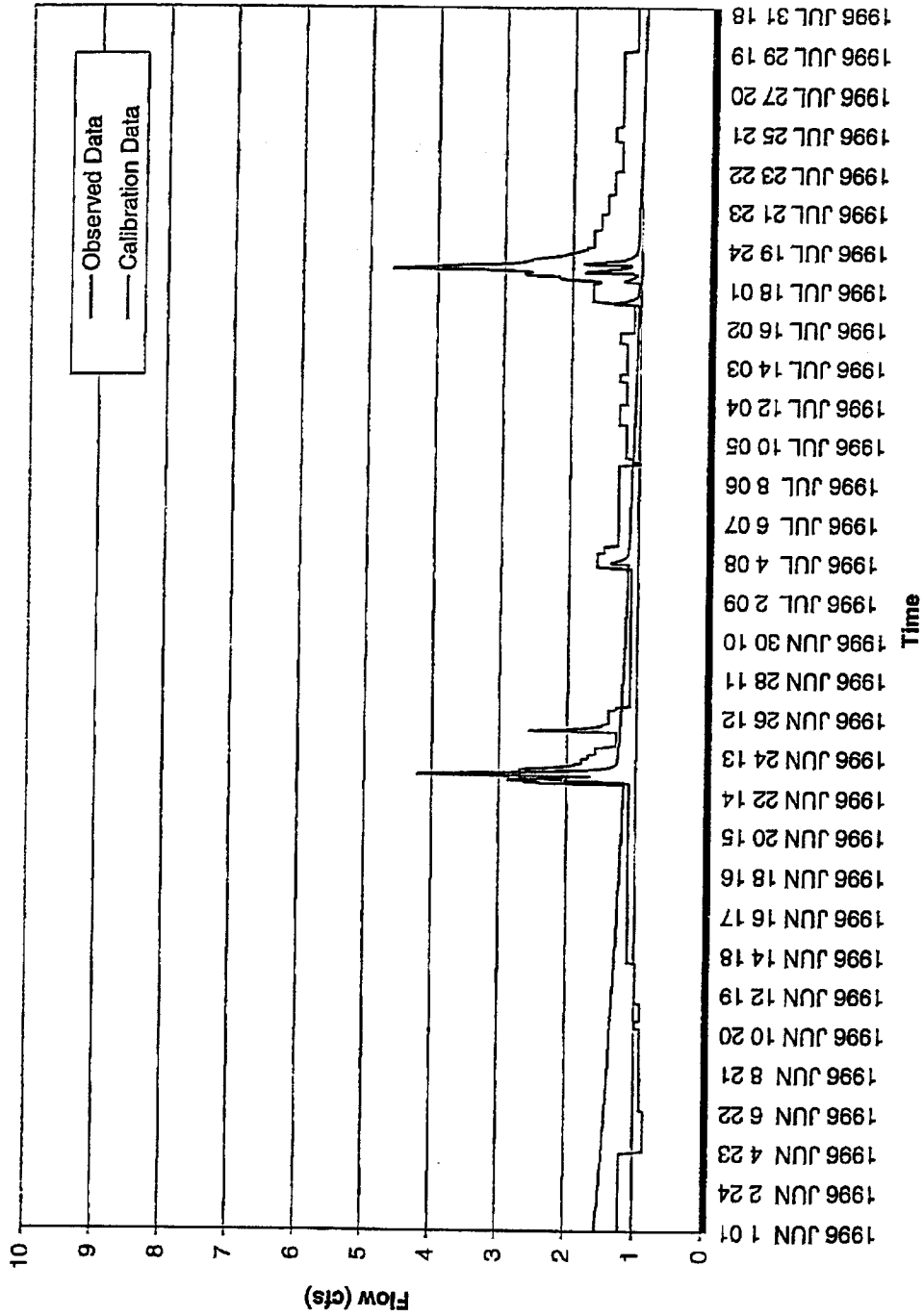

Figure 3-10. Walker Creek Near Wetland Observed vs. Calibrated Low Flow 1996



annual flow near the wetland was 1996, while the year with the lowest average annual flow was 1995. Given that 65 percent of the base flow for Walker Creek was recorded at the upstream gage near the wetland, it is difficult to understand why the year of maximum flow at the mouth was also the year of minimum flow at the upstream gage. Table 3-6 indicates that the 7-day low flow for 1995 at the downstream gage was not consistent with the other years.

Table 3-5. Walker Creek correlation of average annual gage flow at the mouth and near the wetland.

GAGE AT THE MOUTH			
Water-Year	Observed Average Flow (cfs)	Calibrated Average Flow (cfs)	Difference (cfs)
1993	1.879	1.442	0.437
1994	1.584	1.283	0.301
1995	2.318	1.937	0.380
1996	2.034	1.723	0.310
Average Difference	1.953	1.596	0.357

GAGE NEAR THE WETLAND			
Water-Year	Observed Average Flow (cfs)	Calibrated Average Flow (cfs)	Difference (cfs)
1993	1.189	0.978	0.210
1994	1.203	0.898	0.306
1995	1.103	1.232	-0.129
1996	1.515	1.113	0.402
Average Difference	1.252	1.055	0.197

DIFFERENCE BETWEEN GAGES			
Water-Year	Observed Average Flow (cfs)	Calibrated Average Flow (cfs)	Difference (cfs)
1993	0.690	0.464	0.226
1994	0.381	0.385	-0.005
1995	1.215	0.706	0.509
1996	0.519	0.610	-0.091
Average Difference	0.701	0.541	0.160

Table 3-6. Walker Creek correlation of 7-day low-flow gage flow at the mouth and near the wetland.

GAGE AT THE MOUTH			
Water-Year	Observed Average Flow (cfs)	Calibrated Average Flow (cfs)	Difference (cfs)
1993	1.502	0.923	0.579
1994	0.987	0.833	0.154
1995	0.915	1.077	-0.163
1996	1.719	1.287	0.432
Average Difference	1.281	1.030	0.250

GAGE NEAR THE WETLAND			
Water-Year	Observed Average Flow (cfs)	Calibrated Average Flow (cfs)	Difference (cfs)
1993	0.800	0.666	0.134
1994	0.670	0.614	0.056
1995	0.256	0.750	-0.494
1996	0.896	0.870	0.026
Average Difference	0.656	0.725	-0.069

DIFFERENCE BETWEEN GAGES			
Water-Year	Observed Average Flow (cfs)	Calibrated Average Flow (cfs)	Difference (cfs)
1993	0.702	0.257	0.445
1994	0.316	0.219	0.097
1995	0.658	0.327	0.331
1996	0.823	0.417	0.406
Average Difference	0.625	0.305	0.320

4. DES MOINES CREEK LOW STREAMFLOW

Two streamflow gages located in the Des Moines Creek watershed were used in the low-streamflow calibration renew (see Figure 2-1 in the main text for gage locations). One of the streamflow gages was located near the mouth of Des Moines Creek, and the other gage (11c) was located further upstream. Data for the streamflow gages were collected by King County DNR. The analysis period covers water-years 1992 through 1996. The modeling team selected this period because it appeared to contain the most reliable data. However, the observed data from these water-years contain several gaps.

4.1 DES MOINES CREEK AT THE MOUTH

Observed and calibrated low flows for Des Moines Creek at the mouth are shown in Figures 4-1 through 4-5. Average simulated and observed streamflows for each low-flow period are listed in Table 4-1. Average simulated and observed streamflows for each 7-day low-flow period are listed in Table 4-2. The 7-day low-flow period for each observed water-year did not occur during the same 7-day period as the simulated low-flow period. Water-year 1992 exhibited some odd behavior in the month of July, as the observed base flow jumped up and down erratically. For example, on July 15th, the base flow ranged from 0.1 cfs to 1.8 cfs (Table 4-3). This type of flashiness is duplicated throughout the observed data and was not duplicated by the simulated data. In general, low flow at the mouth represents the general behavior of the observed flows. Average simulated flows for water-years 1994 through 1996 were within 0.26 cfs of observed flows, while average simulated flows for water-years 1992 and 1993 were within 0.5 cfs of observed flows. Calibrated 7-day low flows were within 0.32 cfs of observed low flows for all years.

Table 4-1. Des Moines Creek at the mouth, June through November low-flow average flows for water-years 1992 through 1996.

Water-Year	Observed Average Flow (cfs)	Calibrated Average Flow (cfs)	Difference (cfs)
1992	3.370	2.909	0.461
1993	2.726	2.198	0.528
1994	3.146	3.068	0.078
1995	5.754	5.623	0.131
1996	2.534	2.785	-0.251
Average Difference	3.540	3.418	0.122

Figure 4-1. Des Moines Creek at the Mouth Observed vs. Calibrated Low Flow 1992

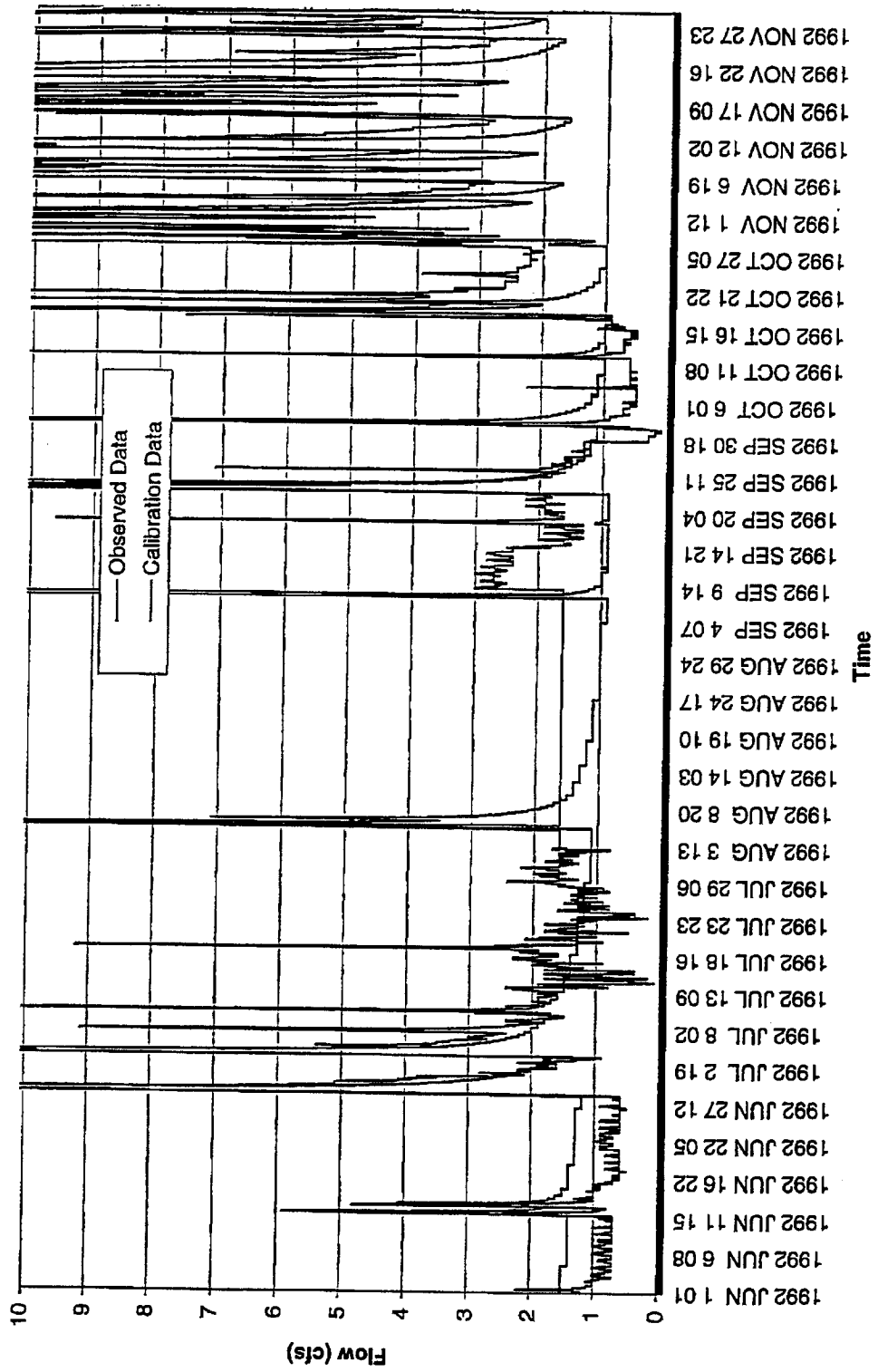

Figure 4-2. Des Moines Creek at the Mouth Observed vs. Calibrated Low Flow 1993

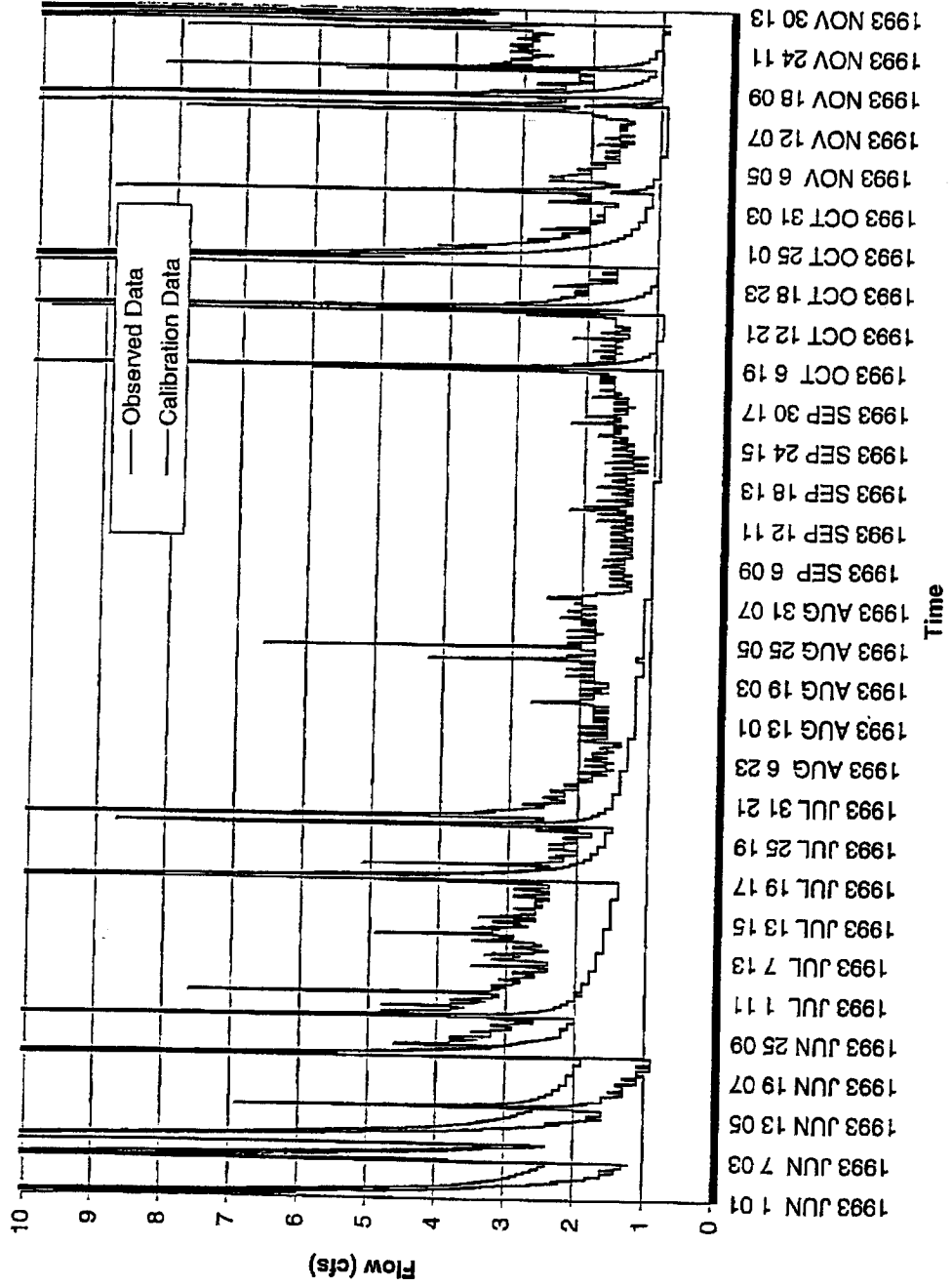

Figure 4-3. Des Moines Creek at the Mouth Observed vs. Calibrated Low Flow 1994

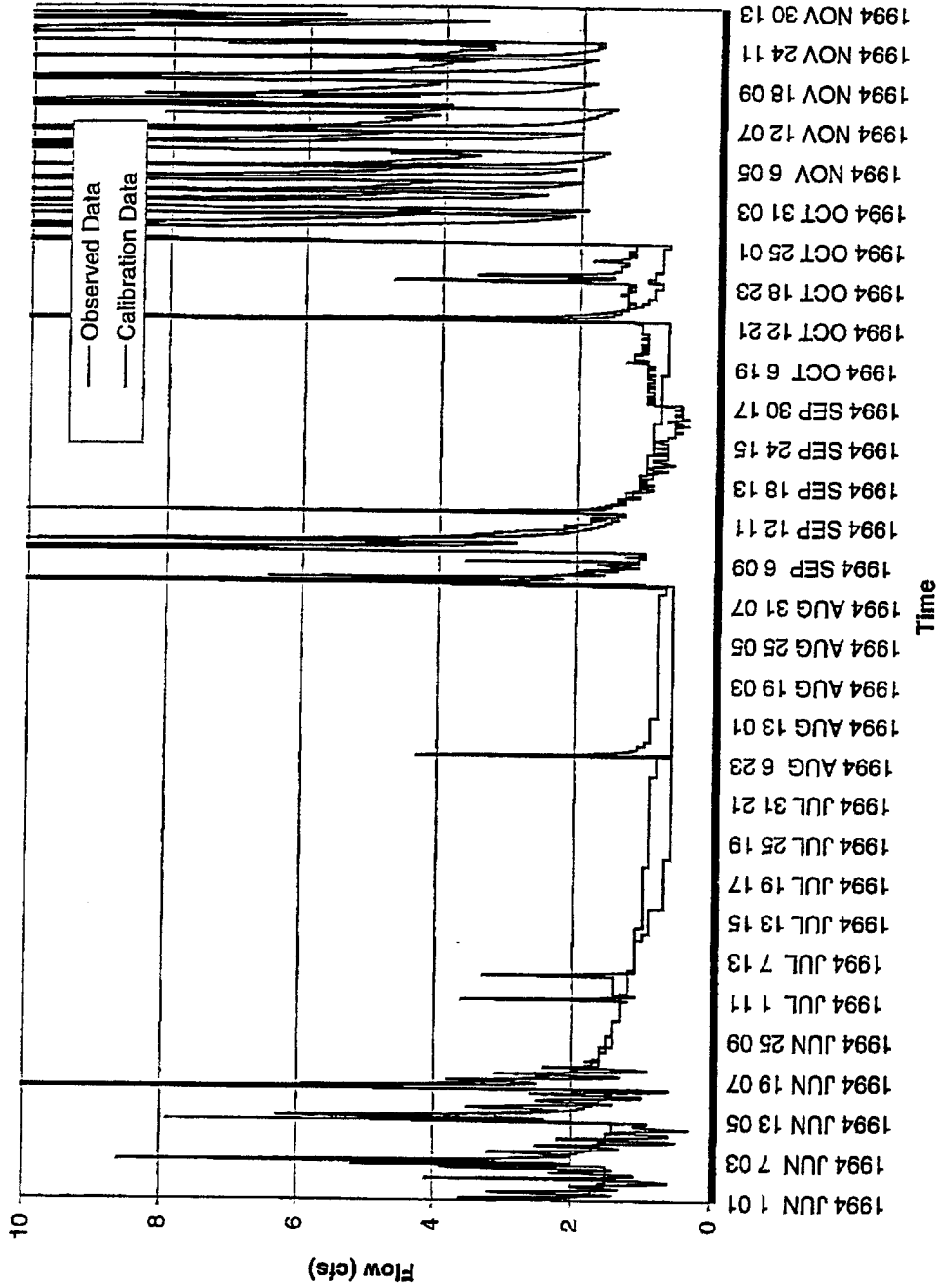

Figure 4-4. Des Moines Creek at the Mouth Observed vs. Calibrated Low Flow 1995

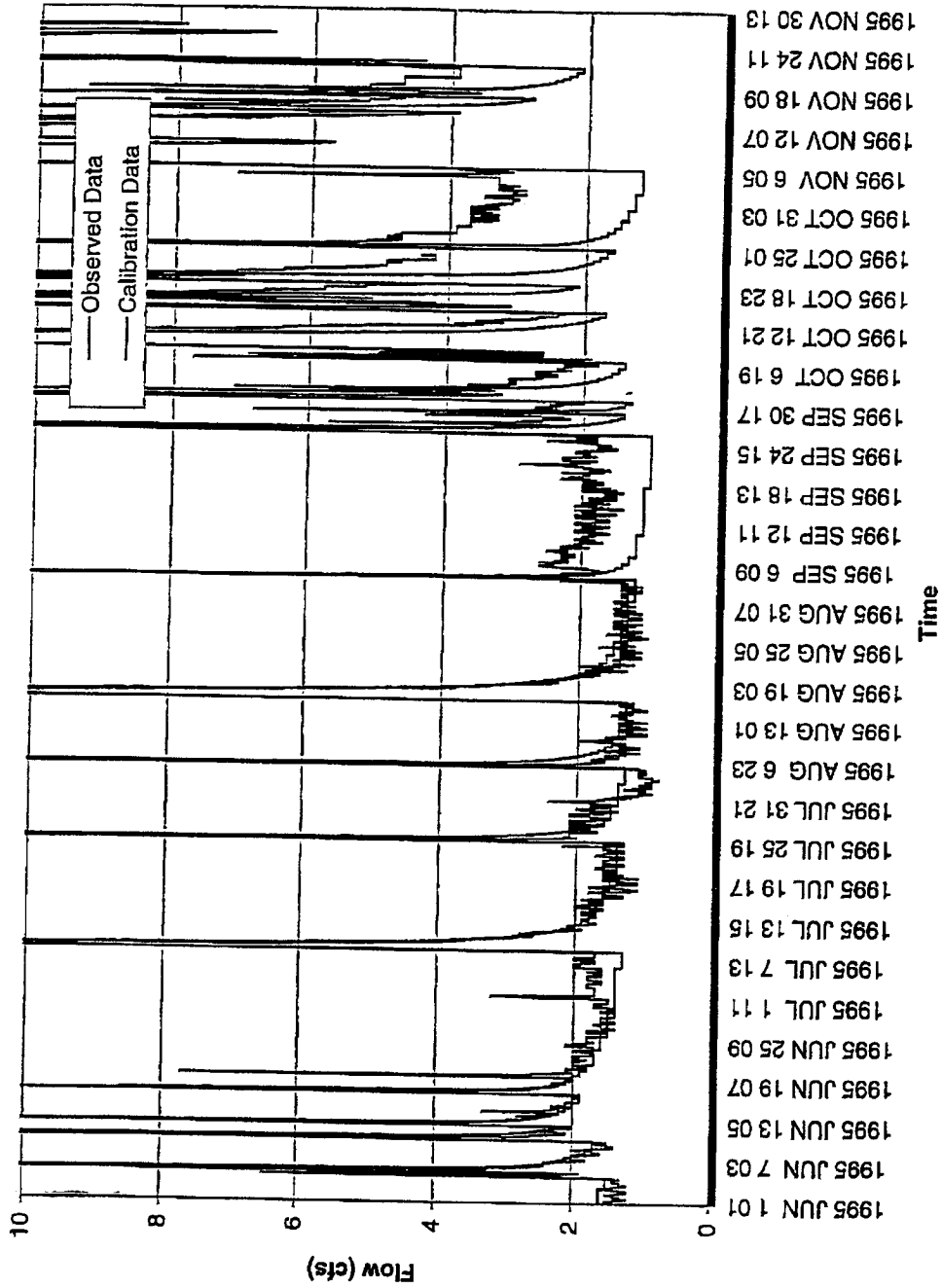

Figure 4-5. Des Moines Creek at the Mouth Observed vs. Calibrated Low Flow 1996

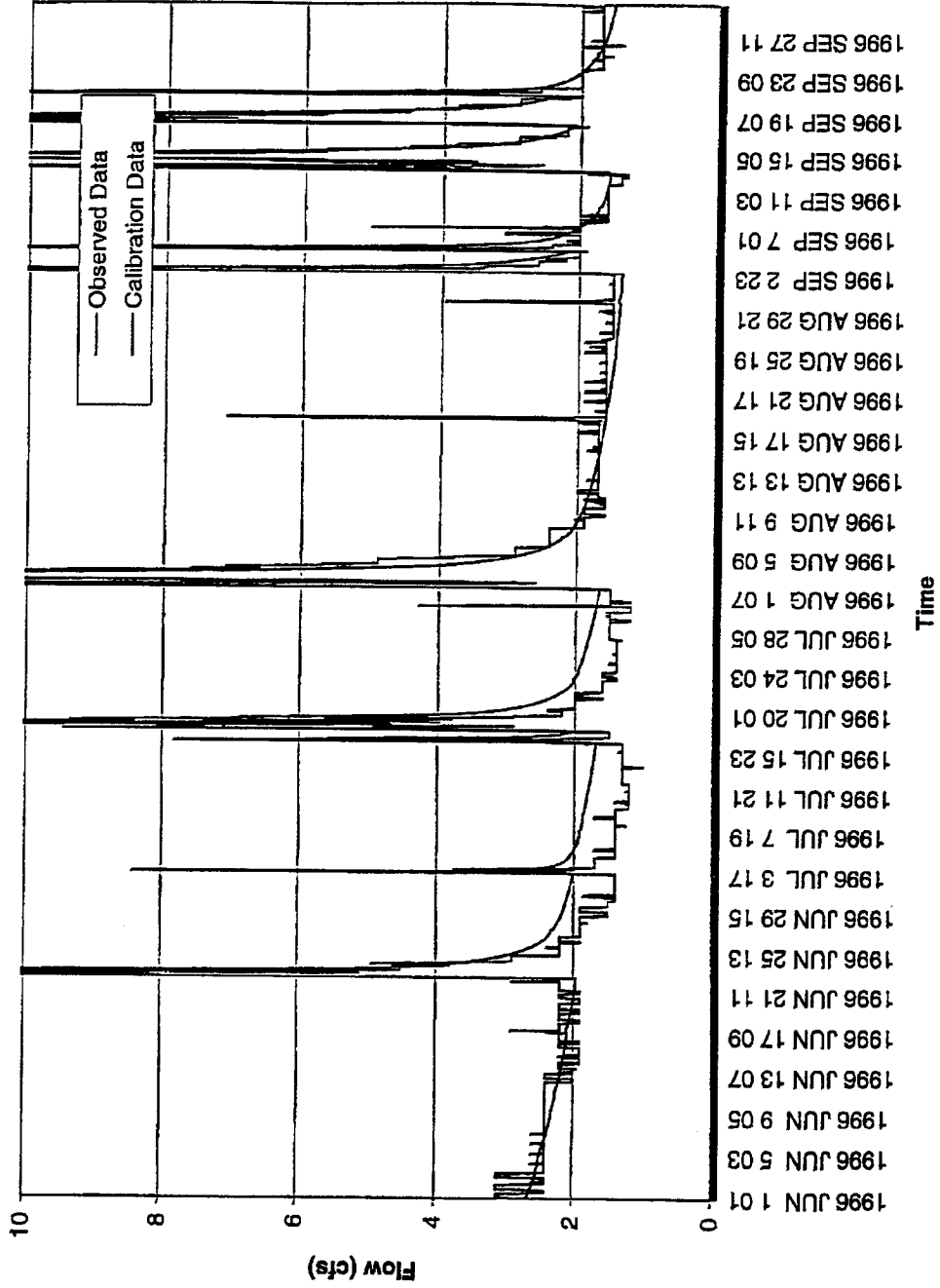

Table 4-2. Des Moines Creek at the mouth, June through November 7-day low flows for water-years 1992 through 1996.

Water-Year	Observed Average Flow (cfs)	Calibrated Average Flow (cfs)	Difference (cfs)
1992	0.585	0.904	-0.318
1993	1.205	0.900	0.305
1994	0.600	0.700	-0.100
1995	1.284	1.000	0.284
1996	1.268	1.411	-0.144
Average Difference	1.089	1.003	0.086

Table 4-3. Des Moines Creek low flow at the mouth, recorded July 15, 1992 base flow.

Date/Hour	Flow (cfs)	Date/Hour	Flow (cfs)
1992 JUL 15 01	0.6	1992 JUL 15 17	1.8
1992 JUL 15 02	0.4	1992 JUL 15 18	1.5
1992 JUL 15 03	0.4	1992 JUL 15 19	0.6
1992 JUL 15 04	0.2	1992 JUL 15 20	0.2
1992 JUL 15 05	0.1	1992 JUL 15 21	0.2
1992 JUL 15 06	0.2	1992 JUL 15 22	0.2
1992 JUL 15 07	0.2	1992 JUL 15 23	0.2
1992 JUL 15 08	0.2	1992 JUL 15 24	0.8
1992 JUL 15 09	0.4		
1992 JUL 15 10	0.4		
1992 JUL 15 11	0.7		
1992 JUL 15 12	0.4		
1992 JUL 15 13	0.9		
1992 JUL 15 14	1.6		
1992 JUL 15 15	1.3		
1992 JUL 15 16	0.9		

4.2 DES MOINES CREEK AT GAGE 11C

Observed and calibrated low flows for Des Moines Creek at gage 11c are shown in Figures 4-6 through 4-11. Average simulated and observed streamflows for each low-flow period are listed in Table 4-4. Average simulated and observed streamflows for each 7-day low-flow period are listed in Table 4-5. The 7-day low-flow period for each observed water-year did not occur during the same 7-day period as the simulated low-flow period. Water-year 1991 had a small gap missing from the observed data.

The simulated average 7-day low flow for all years was consistently lower than the observed low flow. The average difference was 0.61 cfs, with the maximum difference of 1.09 cfs occurring in

Figure 4-6. Des Moines Creek at Gage 11c Observed vs. Calibrated Low Flow 1991

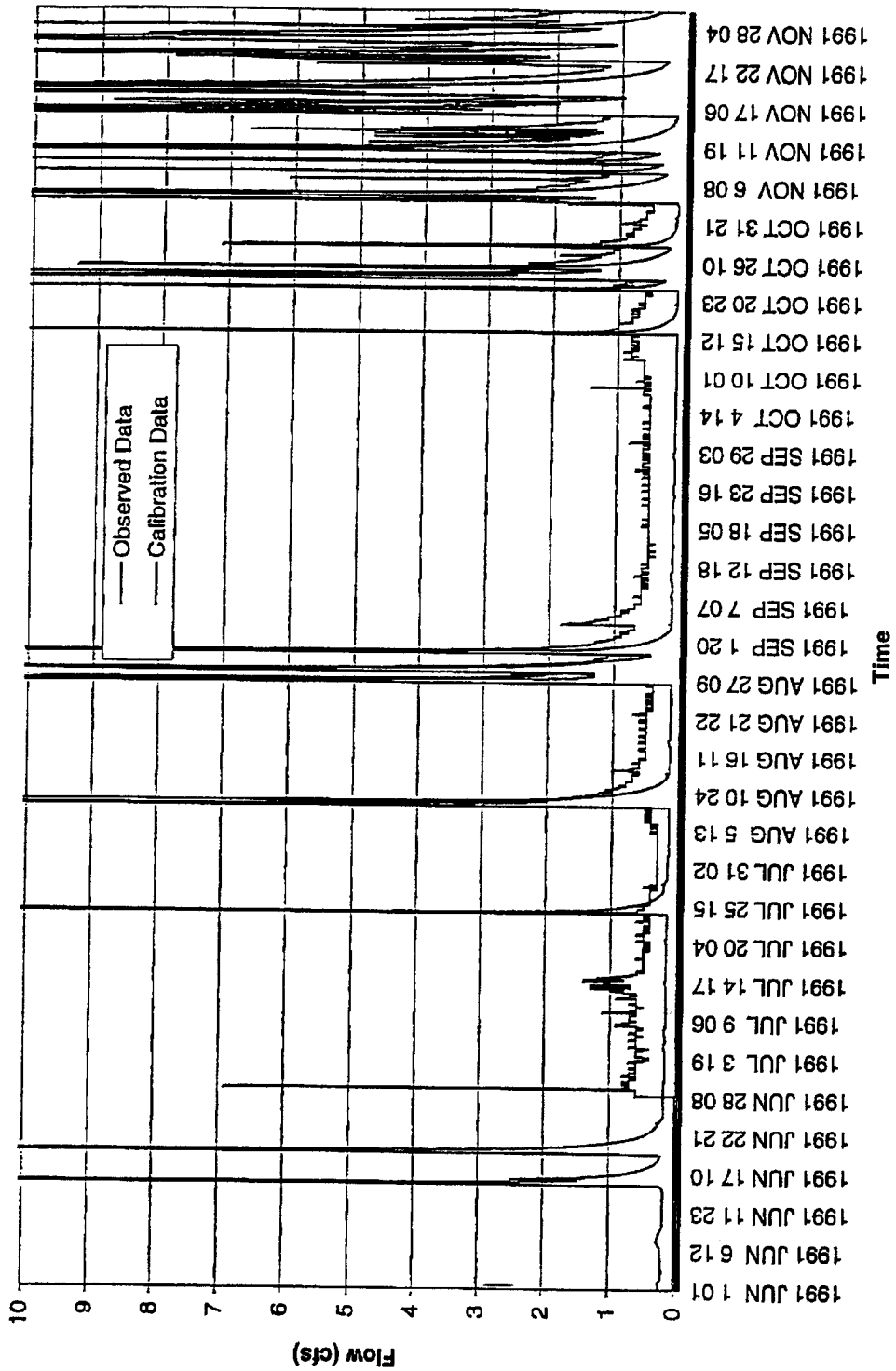

Figure 4-7. Des Moines Creek at Gage 11c Observed vs. Calibrated Low Flow 1992

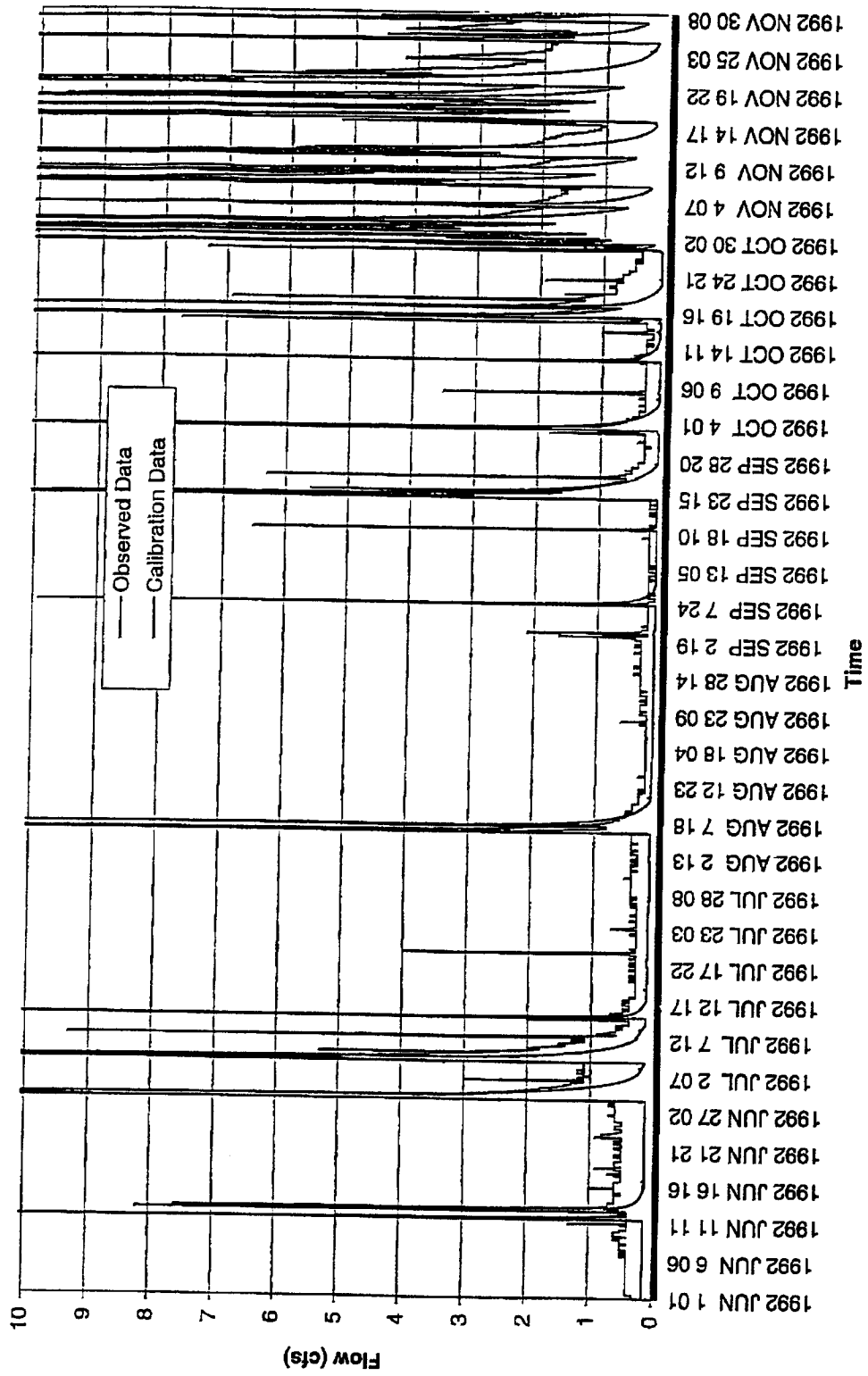

Figure 4-8. Des Moines Creek at Gage 11c Observed vs. Calibrated Low Flow 1993

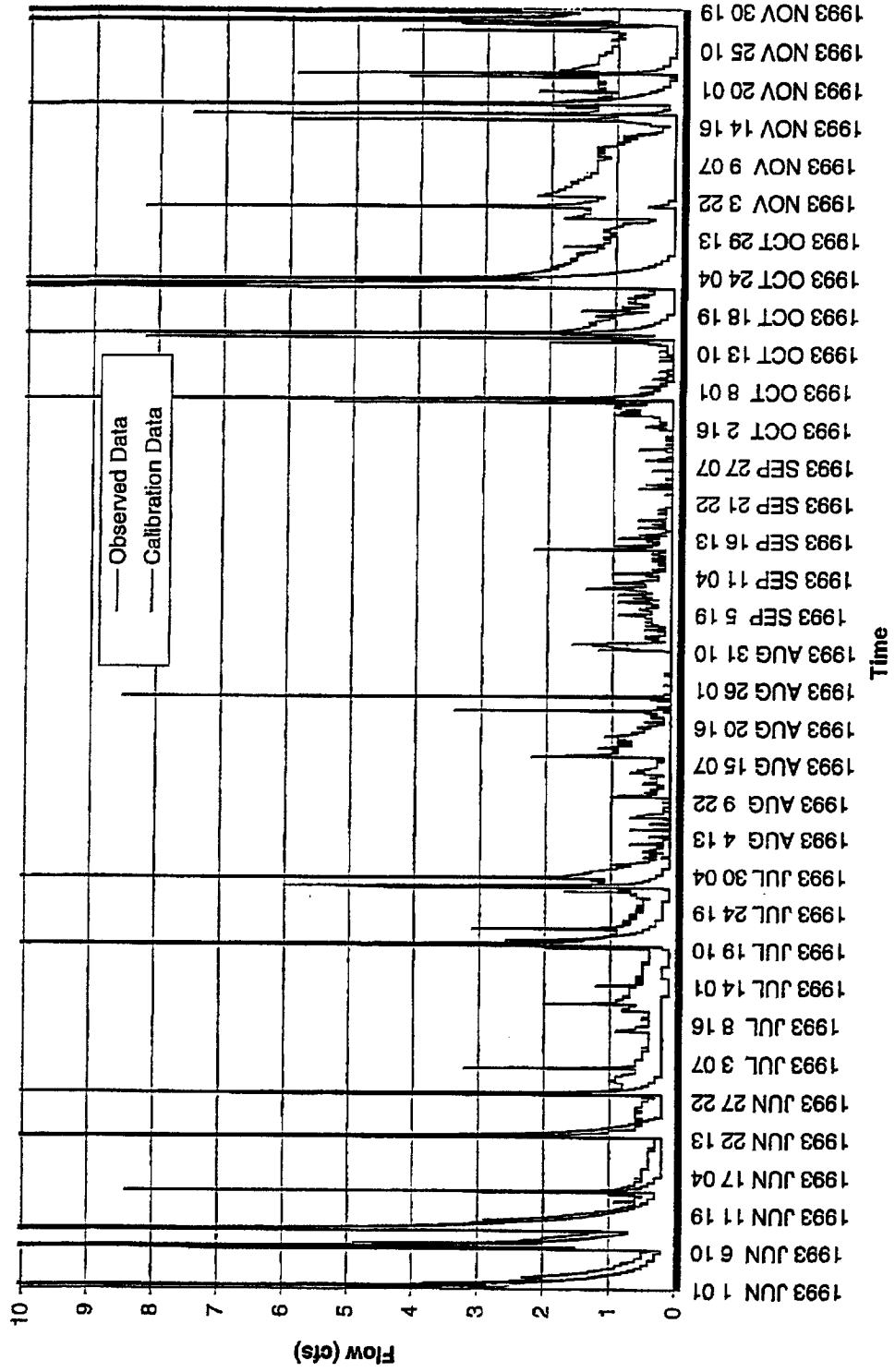

Figure 4-9. Des Moines Creek at Gage 11c Observed vs. Calibrated Low Flow 1994

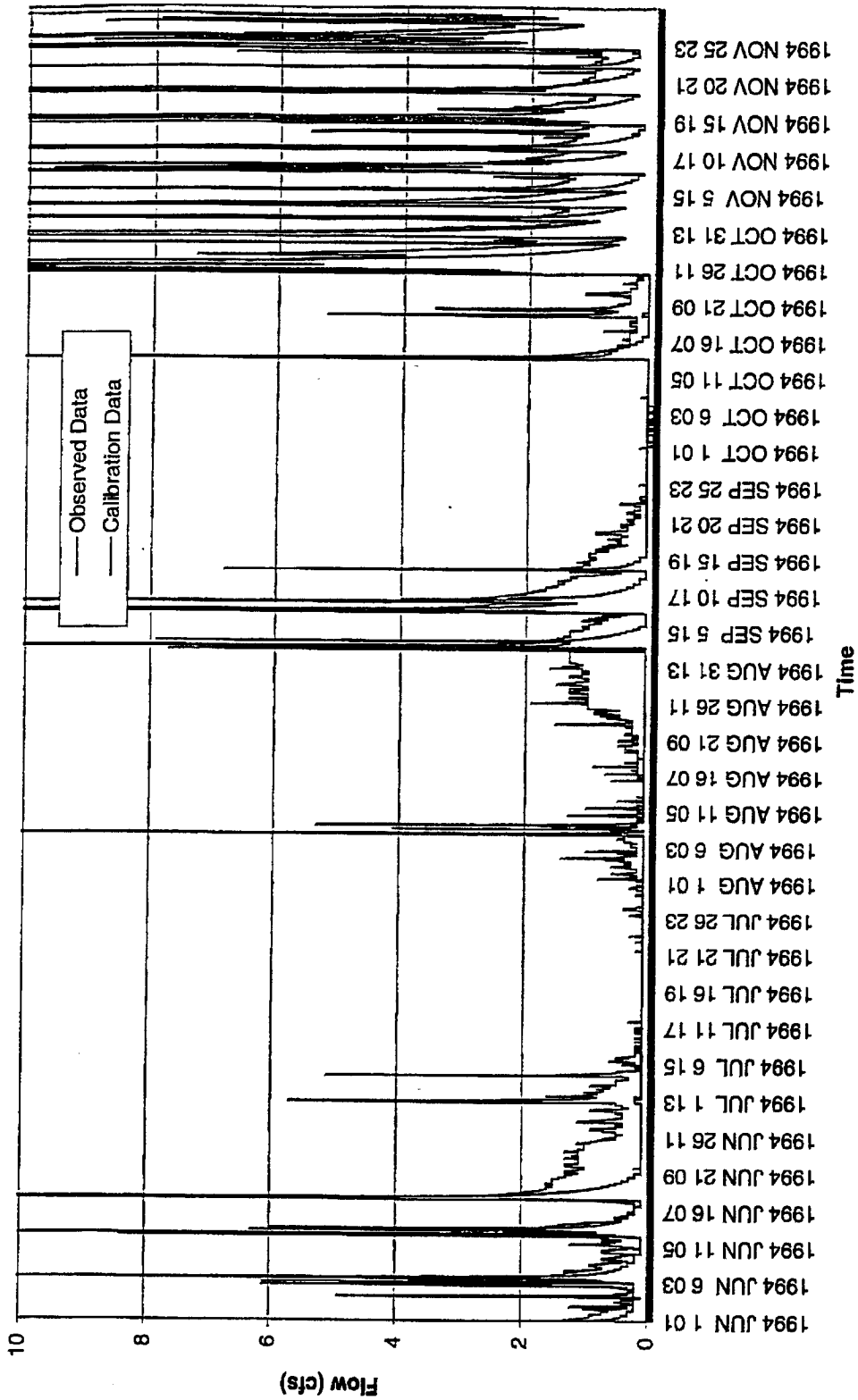

Figure 4-10. Des Moines Creek at Gage 11c Observed vs. Calibrated Low Flow 1995

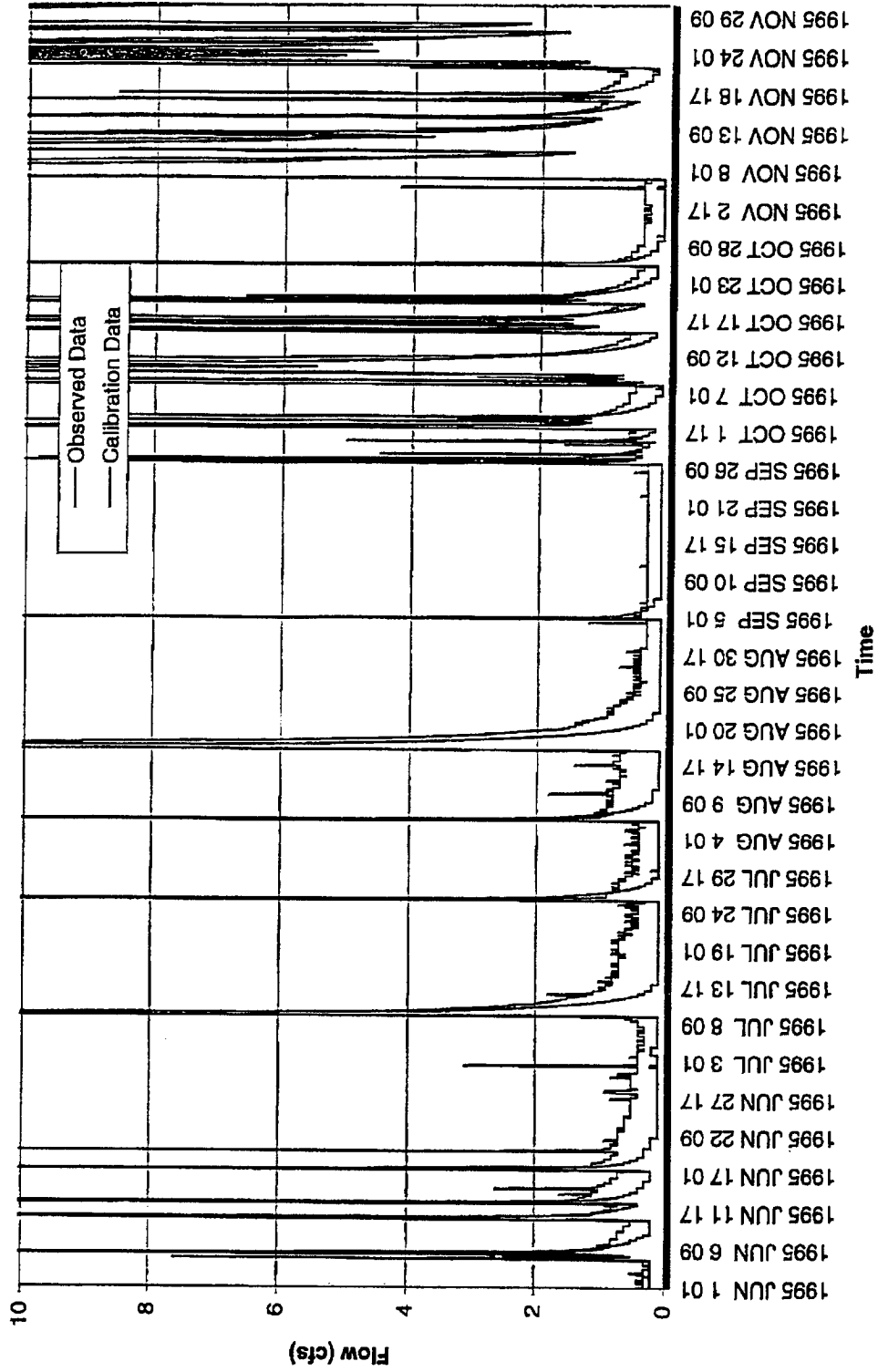
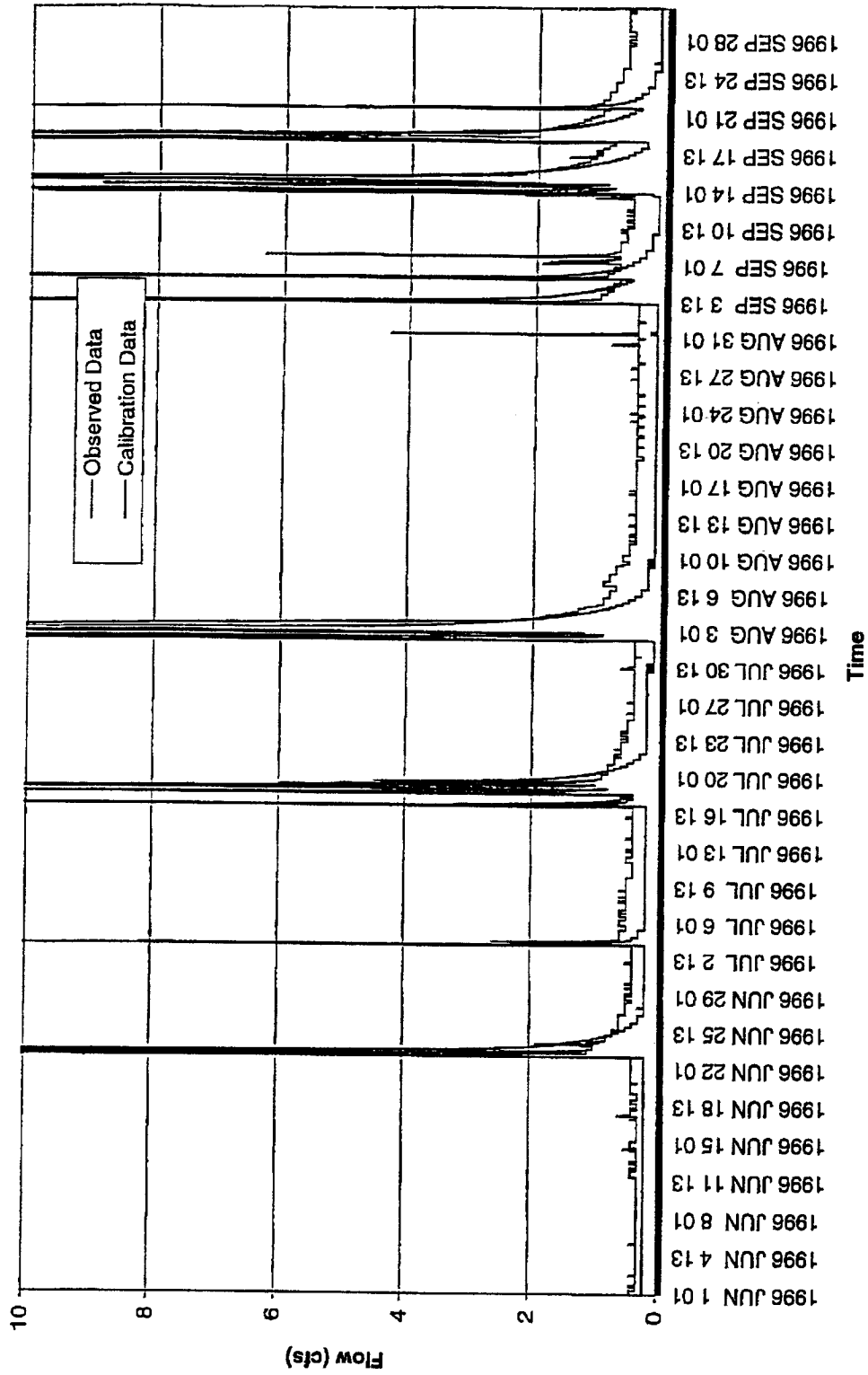

Figure 4-11. Des Moines Creek at Gage 11c Observed vs. Calibrated Low Flow 1996



1995. Calibrated base flows were generally very flat and ranged between 0.1 and 0.2 cfs, while the observed base flow was more flashy and generally ranged between 0.3 and 1.0 cfs. The simulated 7-day low-flow values were within 0.21 cfs of the observed 7-day low-flow values. The observed maximum 7-day low flow for the period of study was 0.3 cfs, while the simulated maximum 7-day low flow for the period of study was 0.2 cfs.

Table 4-4. Des Moines Creek at gage 11c, June through November low-flow average flows for water-years 1991 through 1996.

Water-Year	Observed Average Flow (cfs)	Calibrated Average Flow (cfs)	Difference (cfs)
1991	1.549	0.954	0.596
1992	1.346	0.948	0.398
1993	1.009	0.581	0.428
1994	1.516	1.043	0.472
1995	3.008	1.923	1.085
1996	1.112	0.652	0.460
Average Difference	1.661	1.050	0.611

Table 4-5. Des Moines Creek at gage 11c, June through November 7-day low flows for water-years 1991 through 1996.

Water-Year	Observed Average Flow (cfs)	Calibrated Average Flow (cfs)	Difference (cfs)
1991	0.300	0.100	0.200
1992	0.172	0.090	0.082
1993	0.133	0.100	0.033
1994	0.046	0.100	-0.054
1995	0.300	0.100	0.200
1996	0.301	0.100	0.201
Average Difference	0.195	0.100	0.095

5. SUMMARY

Low-flow analysis was performed for two gage locations in Miller, Walker, and Des Moines Creeks. Results indicate that calibrated low flows at the mouth of each stream are good, while calibrated low flows at the upstream gages show lower flows than observed flows. Groundwater conditions in each of the watersheds are somewhat speculative and may account for these discrepancies at the upstream gage locations.

Description of Low Flow Landuse Summary Tables

- A-1a Miller Creek Surface Water Subbasin Characteristics – 1994 (STIA basins)
- A-1b Miller Creek Surface Water Subbasin Characteristics – 2006 (STIA basins)

- A-2a Miller Creek Contiguous Groundwater Subbasin Characteristics – 1994 (STIA basins)
- A-2b Miller Creek Contiguous Groundwater Subbasin Characteristics – 2006 (STIA basins)

- A-3a Miller Creek Non-Contiguous Groundwater Subbasin Characteristics – 1994 (STIA basins)
- A-3b Miller Creek Non-Contiguous Groundwater Subbasin Characteristics – 2006 (STIA basins)

- A-4a Walker Creek Surface Water Subbasin Characteristics – 1994 (STIA basins)
- A-4b Walker Creek Surface Water Subbasin Characteristics – 2006 (STIA basins)

- A-5a Walker Creek Contiguous Groundwater Subbasin Characteristics – 1994 (STIA basins)
- A-5b Walker Creek Contiguous Groundwater Subbasin Characteristics – 2006 (STIA basins)

- A-6a Walker Creek Non-Contiguous Groundwater Subbasin Characteristics – 1994 (STIA basins)
- A-6b Walker Creek Non-Contiguous Groundwater Subbasin Characteristics – 2006 (STIA basins)

- A-7a Des Moines Creek Surface Water Subbasin Characteristics – 1994 (STIA basins)
- A-7b Des Moines Creek Surface Water Subbasin Characteristics – 2006 (STIA basins)

- A-8a Des Moines Creek Contiguous Groundwater Subbasin Characteristics – 1994 (STIA basins)
- A-8b Des Moines Creek Contiguous Groundwater Subbasin Characteristics – 2006 (STIA basins)

- A-9a Des Moines Non-Contiguous Groundwater Subbasin Characteristics – 1994 (STIA basins)
- A-9b Des Moines Non-Contiguous Groundwater Subbasin Characteristics – 2006 (STIA basins)

Legend for Miller and Walker Surface Water Subbasin Tables

A-1a, A-1b, A-4a, and A-4b

Soil Types:

M	Till	Modified land (Holocene)
Qb	Outwash	Beach deposits (Holocene)
Qpf	Outwash	Sedimentary deposits of pre-Fraser glaciation age (Pleistocene)
Qu	Outwash	Surficial deposits; undivided (Holocene and Pleistocene)
Qvi	Outwash	Ice-contact deposits
Qvr	Outwash	Recessional outwash deposits
Qvri	Till	Silt-dominated deposits
Qvt	Till	Till
Qvu	Outwash	Vashon drift, undivided
Qw	Outwash	Wetland deposits (Holocene)
Qyal	Outwash	Younger alluvium (Holocene)
SA	Wetland	
Flll	Airport fill	
TIA	Total impervious area	
EIA	Effective impervious area	

Land Use Types:

COMM	Commercial
F	Forest
HD	High density residential
LD	Low density residential
MF	Multi-family
OG	Grass or open
STIA	Commercial airport and measured EIA
TRANS	Transport

PERLND numbers refer to the unique soil pervious land segment in HSPF.

IMPLND numbers refer to the impervious land segment in HSPF.

Legend for Des Moines Surface Water Subbasin Tables

A-7a and A7b

Soil Types:

OFF	Outwash forest, flat
OFM	Outwash forest, moderate
OFS	Outwash forest, steep
OF	Outwash forest (all slopes)
OGF	Outwash grass, flat
OGM	Outwash grass, moderate
OGS	Outwash grass, steep
OG	Outwash grass (all slopes)
LAC	Lacustrine (till)
TFF	Till forest, flat
TFM	Till forest, moderate
TFS	Till forest, steep
TF	Till forest (all slopes)
TGF	Till grass, flat
TGM	Till grass, moderate
TGS	Till grass, steep
TG	Till grass (all slopes)
SA	Wetland
IMP	Impervious area
TIA	Total impervious area

Land Use Types:

AP	Commercial airport and measured EIA
C	Commercial
TR	Transport
MF	Multi-family
HD	High density residential
LD	Low density residential
G	Grass or open
F	Forest

PERLND numbers refer to the unique soil pervious land segment in HSPF.
IMPLND numbers refer to the impervious land segment in HSPF.

Legend for Groundwater Subbasin Tables

A-2a, A-2b, A-3a, A-3b, A-5a, A-5b, A-6a, A-6b, A-8a, A-8b, A-9a, and A-9b

PERLND Areas:

For each groundwater subbasin, land uses and soil types correspond to those listed for the respective surface water subbasin. PERLND subtotals are calculated separately based on the land use and soil types that apply to a given subbasin. Results of those calculations have been summarized on the groundwater subbasin tables contained in this appendix.

IMPLND Areas:

Impervious areas have been included on the groundwater subbasin tables for tracking purposes only. Impervious areas have not been included in groundwater models.

AR 020198

Explanation of Calculation of Effective Impervious Area

For all STIA basins:

Effective Impervious Area

- Land use AP/STIA and TR/TRANS: impervious acreage from GIS analysis
- All other land use categories: total acreage within the basin for a given land use and soil type multiplied by the EIA percentage

Pervious Area

- Land use AP/STIA and TR/TRANS: pervious acreage within the basin for a given land use and soil type from GIS analysis
- All other land use categories: total acreage within the basin for a given land use and soil type multiplied by the pervious percentage

AR 020199

Table 1. Miller Creek Surface Water Subbasin Characteristics - 1994 (S₁ Basins)

Land Use	Soil Type	% of total basin equal to EIA	Surface Water Subbasin Areas (Acres)															
			M5		M6		M8		M9		M10		M16		M17			
			Pervious	Effective Impervious	Pervious	Effective Impervious	Pervious	Effective Impervious	Pervious	Effective Impervious	Pervious	Effective Impervious	Pervious	Effective Impervious	Pervious	Effective Impervious		
COMM	Qvr	85%	0.53	3.01	-	-	-	-	-	-	-	-	-	-	-	-	-	-
	Qvrl	85%	2.18	12.34	0.08	0.44	-	-	-	-	-	-	-	-	-	-	-	-
	Qvt	85%	-	-	-	-	-	-	-	-	-	-	-	-	-	-	-	-
F	M	0%	-	-	0.07	-	-	-	-	-	-	-	-	-	-	-	-	-
	Qu	0%	-	-	-	-	-	-	-	-	-	-	-	-	-	-	-	-
	Qvr	0%	-	-	13.43	-	-	-	0.05	-	-	-	-	-	1.17	-	-	-
	Qvrl	0%	-	-	-	-	-	-	-	-	-	-	-	-	0.77	-	-	-
	Qvt	0%	-	-	1.37	-	-	-	4.98	-	-	-	-	-	19.26	-	-	-
	Qw	0%	-	-	-	-	-	-	-	-	4.15	-	-	-	9.76	-	-	-
HD	Qvr	15%	-	-	-	-	-	0.48	-	-	-	-	-	-	-	-	-	-
	Qvrl	15%	-	-	-	-	-	-	-	8.19	-	-	-	-	15.22	-	-	-
	Qw	15%	-	-	5.70	1.01	-	-	14.03	2.48	-	-	-	16.63	2.94	-	-	-
LD	M	4%	-	-	-	-	-	-	-	-	-	-	-	-	-	-	-	-
	Qu	4%	-	-	-	-	-	-	-	-	-	-	-	-	-	-	-	-
	Qvr	4%	-	-	-	-	-	-	-	-	-	-	-	-	0.16	-	-	-
	Qvrl	4%	9.67	0.40	-	-	14.21	-	1.26	0.05	-	-	-	5.78	0.00	-	-	-
	Qvt	4%	-	-	-	-	-	-	-	-	-	-	-	9.38	0.39	-	-	-
	Qw	4%	-	-	-	-	-	-	-	-	-	-	-	-	-	-	-	-
MF	Qvr	47%	-	-	-	-	-	-	-	-	-	-	-	-	-	-	-	-
	Qvrl	47%	0.62	0.55	-	-	6.68	6.92	5.13	4.55	19.97	17.71	-	1.19	1.06	-	-	-
OG	M	0%	-	-	0.21	-	-	-	-	-	-	-	-	-	-	-	-	-
	Qvr	0%	-	-	8.35	-	-	-	-	-	-	-	-	-	-	-	-	-
	Qvrl	0%	39.23	-	-	-	0.84	-	0.10	-	-	-	-	-	-	-	-	-
	Qvt	0%	-	-	-	-	-	-	-	-	-	-	-	-	-	-	-	-
	Qw	0%	8.11	0.47	14.35	-	-	-	-	-	-	-	-	-	-	-	-	-
STIA	M	0%	-	-	-	-	-	-	-	-	-	-	-	-	-	-	-	-
	Qvr	0%	-	-	-	-	-	-	-	-	-	-	-	-	-	-	-	-
	Qvrl	0%	-	-	-	-	-	-	-	-	-	-	-	-	-	-	-	-
	Qwt	0%	-	-	-	-	-	-	-	-	-	-	-	-	-	-	-	-
	TIA	100%	-	-	-	-	-	-	-	-	-	-	-	-	-	-	-	-

Table 1. Miller Creek Surface Water Subbasin Characteristics - 1994 (S
 asins)

Land Use	Soil Type	% of total basin equal to EIA	Surface Water Subbasin Areas (Acres)																
			M5		M6		M8		M9		M10		M16		MG1n				
			Pervious	Effective Impervious	Pervious	Effective Impervious	Pervious	Effective Impervious	Pervious	Effective Impervious	Pervious	Effective Impervious	Pervious	Effective Impervious	Pervious	Effective Impervious			
TRANS M		0%	-	0.03	-	-	-	-	-	-	-	-	-	-	-	-	-	0.10	-
Qvr		0%	-	3.44	-	-	-	-	3.83	-	-	-	-	-	-	-	-	3.82	-
Qvt		0%	-	-	-	-	-	-	-	-	-	-	-	-	-	-	-	-	-
Qvw		0%	-	-	-	-	-	-	0.36	-	-	-	-	-	-	-	-	-	-
TIA		100%	-	-	-	-	-	-	0.01	-	-	-	-	-	-	-	-	-	-
			-	-	4.79	-	-	-	7.21	-	-	-	-	-	-	-	-	-	5.40
Wetland		0%	10.27	0.80	-	-	-	-	-	-	-	-	-	-	-	-	-	-	-
Lake			0.44	-	-	-	-	-	-	-	-	-	-	-	-	-	-	-	-
Mark-df			-	0.07	-	-	-	-	-	-	-	-	-	-	-	-	-	-	-
Other			-	0.01	-	-	-	-	-	-	-	-	-	-	-	-	-	-	-
Basin total:			71.08	16.31	47.84	6.23	22.21	6.60	76.14	22.47	131.32	71.98	92.70	15.62	11.60	0.37			
PERLND areas:																			
(16) Till-Forest			-	1.43	4.98	-	-	-	4.98	-	4.15	-	10.93	-	-	-	-	-	-
(26) Till-Grass			10.29	20.37	14.38	-	-	-	14.38	-	31.94	-	30.30	-	-	-	-	-	-
(34) Outwash-Forest			-	13.43	0.05	-	-	-	0.05	-	-	-	20.03	-	-	-	-	-	-
(44) Outwash-Grass			50.05	11.79	56.71	22.21	-	-	56.71	-	95.23	-	31.43	-	-	-	-	-	-
(54) Wetland			10.74	0.82	76.14	22.21	-	-	76.14	-	131.32	-	92.70	-	-	-	-	-	-
subtotal:			71.08	47.84	6.23	22.21	6.60	22.47	71.98	15.62	11.60	0.37							
IMPLND areas:																			
EIA			16.31	54.07	28.80	22.9%	22.8%	22.9%	98.61	22.8%	203.30	35.4%	108.32	14.4%	11.97	3.1%			
Basin total:			87.39	18.7%	11.5%	11.5%	11.5%	11.5%	11.5%	11.5%	11.5%	11.5%	11.5%	11.5%	11.5%	11.5%			
Percent Impervious																			
NETWORK FACTORS																			
PERLND 16 (IF)			-	1.435	4.981	-	-	-	4.981	-	4.155	-	10.932	-	-	-	-	-	-
PERLND 26 (TG)			10.293	20.373	14.384	-	-	-	14.384	-	31.943	-	30.304	-	-	-	-	-	-
PERLND 34 (OF)			-	13.426	0.048	-	-	-	0.048	-	-	-	20.035	-	-	-	-	-	-
PERLND 44 (OG)			50.047	11.790	56.712	22.208	-	-	56.712	-	95.227	-	31.426	-	-	-	-	-	-
PERLND 54 (SA)			10.742	0.816	76.142	22.472	-	-	76.142	-	131.322	-	92.702	-	-	-	-	-	-
IMPLND 14 (EIA)			16.310	6.233	6.598	6.598	-	-	6.598	-	71.975	-	15.619	-	-	-	-	-	-
SUM			87.392	54.073	28.804	28.804	28.804	28.804	98.608	22.472	203.300	35.4%	108.315	14.4%	11.966	3.1%			

Miller Creek Surface Water Subbasin Characteristics - 1994 (asfms)

Land Use	Soil Type	% of total basin equal to EIA	Surface Water Subbasin Areas (Acres)																
			MC2		MC3		MC4		MC5		MC8		MC7		CARGO				
			Pervious	Effective Impervious	Pervious	Effective Impervious	Pervious	Effective Impervious	Pervious	Effective Impervious	Pervious	Effective Impervious	Pervious	Effective Impervious	Pervious	Effective Impervious			
COMM	Qvr	85%	-	-	-	-	-	-	-	-	-	-	-	-	-	-	-	-	-
	Qvrl	85%	-	-	-	-	-	-	-	-	-	-	-	-	-	-	-	-	-
	Qvt	85%	-	-	-	-	-	-	-	-	-	-	-	-	-	-	-	-	-
F	M	0%	0.08	-	-	-	-	-	-	-	-	-	-	-	-	-	-	-	-
	Qu	0%	-	-	-	-	-	-	-	-	-	-	-	-	-	-	-	-	-
	Qvr	0%	6.66	5.53	0.05	-	-	-	-	-	-	-	-	-	-	-	-	-	-
	Qvrl	0%	-	-	-	-	-	-	-	-	-	-	-	-	-	-	-	-	-
	Qvt	0%	-	-	-	-	-	-	-	-	-	-	-	-	-	-	-	-	-
	Qw	0%	4.17	1.28	-	-	-	-	-	-	-	-	-	-	-	-	-	-	-
HD	Qvr	15%	-	-	9.41	1.66	0.30	0.05	0.31	2.77	0.49	-	-	-	-	-	-	-	-
	Qvrl	15%	-	-	-	-	-	-	-	-	-	-	-	-	-	-	-	-	-
	Qvt	15%	-	-	0.92	0.16	-	-	-	-	-	-	-	-	-	-	-	-	-
	Qw	15%	-	-	-	-	-	-	-	-	-	-	-	-	-	-	-	-	-
				-	-	-	-	-	-	-	-	-	-	-	-	-	-	-	-
LD	M	4%	-	-	-	-	-	-	-	-	-	-	-	-	-	-	-	-	-
	Qu	4%	-	-	-	-	-	-	-	-	-	-	-	-	-	-	-	-	-
	Qvr	4%	-	-	3.43	0.14	30.11	1.25	0.49	23.01	0.96	-	-	-	-	-	-	-	-
	Qvrl	4%	-	-	-	-	-	-	-	-	-	-	-	-	-	-	-	-	-
	Qvt	4%	-	-	-	-	-	-	-	-	-	-	-	-	-	-	-	-	-
	Qw	4%	-	-	0.33	0.01	13.49	0.56	-	0.05	0.00	-	-	-	-	-	-	-	-
MF	Qvr	47%	-	-	0.07	0.06	0.71	0.63	-	-	-	-	-	-	-	-	-	-	-
	Qvrl	47%	-	-	-	-	-	-	-	-	-	-	-	-	-	-	-	-	-
OG	M	0%	0.82	-	-	-	-	-	-	-	-	-	-	-	-	-	-	-	-
	Qvr	0%	7.86	1.16	6.56	-	-	-	-	4.74	-	-	-	-	-	-	-	-	-
	Qvrl	0%	-	-	-	-	-	-	-	-	-	-	-	-	-	-	-	-	-
	Qvt	0%	-	-	-	-	-	-	-	-	-	-	-	-	-	-	-	-	-
	Qw	0%	0.55	0.05	7.51	-	-	-	-	0.04	-	-	-	-	-	-	-	-	-
STIA	M	0%	-	-	-	-	-	-	-	-	-	-	-	-	-	-	-	-	-
	Qvr	0%	-	-	-	-	-	-	-	-	-	-	-	-	-	-	-	-	-
	Qvrl	0%	-	-	-	-	-	-	-	-	-	-	-	-	-	-	-	-	-
	Qwt	0%	-	-	-	-	-	-	-	-	-	-	-	-	-	-	-	-	-
	TIA	100%	-	-	-	-	-	-	-	-	-	-	-	-	-	-	-	-	-

Table Miller Creek Surface Water Subbasin Characteristics - 1994 (S asins)

Land Use	Soil Type	% of total basin equal to EIA	Surface Water Subbasin Areas (Acres)															
			MC2		MC3		MC4		MC5		MC6		MC7		CARGO			
			Pervious	Effective Impervious	Pervious	Effective Impervious	Pervious	Effective Impervious	Pervious	Effective Impervious	Pervious	Effective Impervious	Pervious	Effective Impervious	Pervious	Effective Impervious		
TRANS M		0%	0.02	-	-	-	-	-	-	-	-	-	-	-	-	-	-	-
Qvr		0%	2.55	-	-	-	-	-	-	-	-	-	-	-	-	-	-	-
Qvrl		0%	-	-	-	-	-	-	-	-	-	-	-	-	-	-	-	-
Qw		0%	-	-	-	-	-	-	-	-	-	-	-	-	-	-	-	-
TIA		100%	0.22	0.27	0.43	0.01	-	-	-	-	-	-	-	-	-	-	-	-
Wetland		0%	10.30	-	0.52	-	5.94	-	7.60	-	0.99	-	3.47	-	-	-	-	-
Lake			2.98	-	-	3.35	-	0.76	-	-	0.29	-	0.24	-	-	-	-	-
Crck-df			7.00	-	13.17	-	-	-	-	-	-	-	-	-	-	-	-	-
Other			-	-	-	-	-	-	-	-	-	-	-	-	-	-	-	-
Basin total:			33.04	0.27	12.83	0.11	34.22	2.04	52.21	2.50	14.55	0.80	43.24	3.05	7.04	1.07		
PERLND areas:																		
(16) Till-Forest			0.08	-	-	-	-	-	13.49	-	-	-	9.23	-	7.04	-	-	-
(26) Till-Grass			0.64	-	-	-	-	-	-	-	-	-	-	-	-	-	-	-
(34) Outwash-Forest			6.66	-	5.53	-	0.05	-	31.13	-	13.56	-	30.54	-	-	-	-	-
(44) Outwash-Grass			10.41	-	5.03	-	19.47	-	7.60	-	0.99	-	3.47	-	-	-	-	-
(54) Wetland			15.25	-	2.27	-	14.70	-	52.21	-	14.55	-	43.24	-	7.04	-	-	-
subtotal:			33.04	-	12.83	-	34.22	-	52.21	-	14.55	-	43.24	-	7.04	-	-	-
IMPLND areas:																		
EIA			-	0.27	0.11	-	-	2.04	-	2.50	-	0.80	-	3.05	-	1.07	-	-
Basin total:			33.31	0.27	12.94	0.11	36.26	5.6%	54.71	4.6%	15.35	5.2%	46.29	6.6%	8.12	13.2%		
Percent Impervious				0.8%	0.9%													
NETWORK FACTORS																		
PERLND 16 (TF)			0.078	-	-	-	-	-	13.487	-	-	-	9.227	-	7.043	-	-	-
PERLND 26 (TG)			0.635	-	-	-	-	-	-	-	-	-	-	-	-	-	-	-
PERLND 34 (OF)			6.663	-	5.526	-	0.049	-	31.127	-	13.561	-	30.540	-	-	-	-	-
PERLND 44 (OG)			10.414	-	5.033	-	19.470	-	7.596	-	0.987	-	3.469	-	-	-	-	-
PERLND 54 (SA)			15.250	-	2.273	-	14.700	-	2.503	-	0.799	-	3.052	-	1.074	-	-	-
IMPLND 14 (EIA)			0.270	0.112	0.112	-	2.043	-	54.714	-	15.347	-	46.288	-	8.117	-	-	-
SUM			33.311	12.943	12.943	36.263	36.263	54.714	54.714	4.6%	15.347	5.2%	46.288	6.6%	8.117	13.2%		

Table 1. Miller Creek Surface Water Subbasin Characteristics - 1994 (Sasins)

Land Use		Soil Type	% of total basin equal to EIA		Surface Water Subbasin Areas (Acres)													
COMM	Qvr	Qvr	85%	85%	NEPL	SDN1		SDN1-LWR		SDN1-OFF		SDN2-Xn		SDN3		SDN-3A-1		
			Pervious	Effective	Pervious	Effective	Pervious	Effective	Pervious	Effective	Pervious	Effective	Pervious	Effective	Pervious	Effective	Pervious	Effective
			Impervious	Impervious	Impervious	Impervious	Impervious	Impervious	Impervious	Impervious	Impervious	Impervious	Impervious	Impervious	Impervious	Impervious	Impervious	Impervious
		Qvr	0.15	0.87	-	-	-	-	-	-	-	-	-	-	-	-	-	-
		Qvr	-	-	-	-	-	-	-	-	-	-	-	-	-	-	-	-
F		M	8.78	-	-	-	-	-	-	-	-	-	-	-	-	-	-	-
		Qu	-	-	-	-	-	-	-	-	-	-	-	-	-	-	-	-
		Qvr	-	-	-	-	-	-	-	-	-	-	-	-	-	-	-	-
		Qvr	-	-	-	-	-	-	-	-	-	-	-	-	-	-	-	-
		Qvr	-	-	-	-	-	-	-	-	-	-	-	-	-	-	-	-
		Qw	-	-	-	-	-	-	-	-	-	-	-	-	-	-	-	-
HD		Qvr	-	-	-	-	-	-	-	-	-	-	-	-	-	-	-	-
		Qvr	-	-	-	-	-	-	-	-	-	-	-	-	-	-	-	-
		Qvr	-	-	-	-	-	-	-	-	-	-	-	-	-	-	-	-
		Qw	-	-	-	-	-	-	-	14.65	-	-	-	-	-	-	-	-
		Qw	-	-	-	-	-	-	-	2.58	-	-	-	-	-	-	-	-
LD		M	-	-	-	-	-	-	-	-	-	-	-	-	-	-	-	-
		Qu	-	-	-	-	-	-	-	-	-	-	-	-	-	-	-	-
		Qvr	-	-	-	-	-	-	-	-	-	-	-	-	-	-	-	-
		Qvr	-	-	-	-	-	-	-	-	-	-	-	-	-	-	-	-
		Qvr	-	-	-	-	-	-	-	-	-	-	-	-	-	-	-	-
		Qw	-	-	-	-	-	-	-	-	-	-	-	-	-	-	-	-
		Qw	-	-	-	-	-	-	-	-	-	-	-	-	-	-	-	-
MF		Qvr	-	-	-	-	-	-	-	-	-	-	-	-	-	-	-	-
		Qvr	-	-	-	-	-	-	-	-	-	-	-	-	-	-	-	-
OG		M	-	-	-	-	-	-	-	-	-	-	-	-	-	-	-	-
		Qvr	2.40	-	1.05	-	4.87	-	0.00	-	-	1.14	-	0.02	-	-	-	-
		Qvr	-	-	-	-	-	-	0.37	-	-	3.12	-	-	-	-	-	-
		Qvr	-	-	-	-	-	-	-	-	-	-	-	-	-	-	-	-
		Qvr	21.32	-	1.82	-	-	-	3.40	-	-	-	-	7.85	-	1.09	-	-
		Qw	-	-	-	-	-	-	-	-	-	-	-	-	5.27	-	-	-
STIA		M	-	-	-	-	-	-	-	-	-	-	-	-	-	-	-	-
		Qvr	-	-	0.47	-	-	-	-	-	-	-	-	6.62	-	-	-	-
		Qvr	-	-	1.93	-	-	-	-	-	-	-	-	18.87	-	-	-	-
		Qw	-	-	0.17	-	-	-	-	-	-	-	-	-	-	-	-	-
		TIA	-	-	8.69	-	-	-	-	-	-	-	-	-	-	-	-	14.50

AR 020204

Table 1. Miller Creek Surface Water Subbasin Characteristics - 1994 (Sasins)

Land Use	Soil Type	% of total basin equal to EIA	Surface Water Subbasin Areas (Acres)														
			NEPL		SDN1		SDN1-LWR		SDN1-OFF		SDN2-Xn		SDN3		SDN-3A-1		
			Pervious	Effective Impervious	Pervious	Effective Impervious	Pervious	Effective Impervious	Pervious	Effective Impervious	Pervious	Effective Impervious	Pervious	Effective Impervious	Pervious	Effective Impervious	
TRANS M		0%	-	-	-	-	-	-	-	-	-	-	-	-	-	-	-
	Qvr	0%	-	0.78	-	0.10	-	0.68	-	-	-	-	-	-	-	-	-
	Qvl	0%	-	-	-	-	-	3.28	-	-	-	-	-	-	-	-	-
	Qvl	0%	-	-	-	-	-	-	-	-	-	-	-	-	-	-	-
	Qw	0%	-	0.03	-	-	1.76	-	-	-	-	-	-	-	-	-	-
	TIA	100%	-	-	-	1.22	0.38	1.63	7.88	-	-	-	-	-	-	-	-
Wetland		0%	-	-	-	0.07	-	0.04	-	-	-	-	-	-	-	-	-
Lake			-	-	-	-	-	-	-	-	-	-	-	-	-	-	-
Meek-df			-	-	-	-	-	-	-	-	-	-	-	-	-	-	-
Other			-	-	-	-	-	0.04	-	-	-	-	-	-	-	-	-
Basin total:			41.42	0.87	6.24	9.90	5.04	25.81	10.46	4.28	-	33.36	14.50	10.13	0.40		
PERLND areas:			8.77		3.74			20.48		1.14		33.36		5.27			
(16) Till-Forest			21.47											1.03			
(26) Till-Grass			8.78		2.29		4.97	3.65		3.12				3.82			
(34) Outwash-Forest			2.40		0.20		0.07	1.67									
(44) Outwash-Grass			-		6.24		5.04	25.81		4.26		33.36		10.13			
(54) Wetland subtotal:			41.42														
IMPLND areas:				0.87		9.90		10.46					14.50				
EIA			42.29		16.14		6.42	36.27		4.26		47.86		10.52			
Basin total:			42.29		16.14		6.42	36.27		4.26		47.86		10.52			
Percent Impervious			2.1%		61.4%		7.0%	28.8%		0.0%		30.3%		3.8%			
NETWORK FACTORS																	
PERLND 16 (TF)			8.771		3.743			20.485		1.138		33.359		5.272			
PERLND 26 (TG)			21.470											1.028			
PERLND 34 (OF)			8.779		2.292		4.974	3.651		3.122				3.825			
PERLND 44 (OG)			2.398		0.200		0.071	1.673									
PERLND 54 (SA)			-		9.904		0.378	10.461				14.497		0.399			
IMPLND 14 (EIA)			0.873		16.139		5.423	36.269		4.260		47.856		10.524			
SUM			42.291		16.139		5.423	36.269		4.260		47.856		10.524			

Table 1. Miller Creek Surface Water Subbasin Characteristics - 1994 (S jasins)

Land Use	Soil Type	% of total basin equal to EIA	Surface Water Subbasin Areas (Acres)															
			SDN-3A-O		SDN3-X		SDN4		SDN4-X		SDW-1A-I		SDW-1A-O		SDW-1B-I			
			Pervious	Effective Impervious	Pervious	Effective Impervious	Pervious	Effective Impervious	Pervious	Effective Impervious	Pervious	Effective Impervious	Pervious	Effective Impervious	Pervious	Effective Impervious		
COMM	Qvr	85%	-	-	-	-	-	-	-	-	-	-	-	-	-	-	-	-
	Qvt	85%	-	-	-	-	-	-	-	-	-	-	-	-	-	-	-	-
F	M	0%	-	-	-	-	-	-	-	-	-	-	-	-	-	-	-	-
	Qu	0%	-	-	-	-	-	-	-	-	-	-	-	-	-	-	-	-
	Qvr	0%	8.09	12.20	-	1.22	-	-	-	-	-	-	-	-	-	-	-	-
	Qvt	0%	-	0.65	-	-	-	-	-	-	-	-	-	-	-	-	-	-
	Qw	0%	-	-	-	-	-	-	-	-	-	-	-	-	-	-	-	-
HD	Qvr	15%	8.28	1.46	-	-	-	-	-	-	-	-	-	0.06	0.01	-	0.75	0.13
	Qvt	15%	-	-	-	-	-	-	-	-	-	-	-	-	-	-	-	-
	Qvt	15%	-	-	-	-	-	-	-	-	-	-	-	-	-	-	-	-
	Qw	15%	-	-	-	-	-	-	-	-	-	-	-	-	-	-	4.63	0.82
LD	M	4%	-	-	-	-	-	-	-	-	-	-	-	-	-	-	-	-
	Qu	4%	-	-	-	-	-	-	-	-	-	-	-	-	-	-	-	-
	Qvr	4%	0.16	0.01	-	-	-	-	-	-	-	-	-	12.14	0.51	-	4.95	0.21
	Qvt	4%	-	-	-	-	-	-	-	-	-	-	-	-	-	-	-	-
	Qvt	4%	-	-	-	-	-	-	-	-	-	-	-	-	-	-	-	-
	Qw	4%	-	-	-	-	-	-	-	-	-	-	-	-	-	-	-	-
MF	Qvr	47%	-	-	-	-	-	-	-	-	-	-	-	-	-	-	-	-
	Qvt	47%	-	-	-	-	-	-	-	-	-	-	-	-	-	-	-	-
OG	M	0%	-	-	-	-	-	-	-	-	-	-	-	-	-	-	-	-
	Qvr	0%	1.74	5.01	4.70	0.22	-	-	-	-	-	-	-	-	-	-	2.49	-
	Qvt	0%	-	-	3.18	9.51	-	-	-	-	-	-	-	-	-	-	14.61	-
	Qvt	0%	-	-	-	-	-	-	-	-	-	-	-	-	-	-	-	-
	Qw	0%	-	6.94	-	0.71	-	-	-	-	-	-	-	-	-	-	31.33	-
	Qw	0%	-	-	-	-	-	-	-	-	-	-	-	-	-	-	-	-
STIA	M	0%	-	-	19.72	1.83	-	-	-	-	-	-	-	-	-	-	14.15	-
	Qvr	0%	-	-	0.02	0.66	-	-	-	-	-	-	-	-	-	-	-	-
	Qvt	0%	-	-	0.06	-	-	-	-	-	-	-	-	-	-	-	-	-
	Qw	0%	-	-	-	-	-	-	-	-	-	-	-	-	-	-	-	-
	TIA	100%	-	-	-	-	-	-	-	-	-	-	-	-	-	-	-	-
			2.63	1.05	-	-	-	-	-	-	-	-	-	-	-	-	-	-

Table Miller Creek Surface Water Subbasin Characteristics - 1994 (S basins)

Land Use	Soil Type	% of total basin equal to EIA	Surface Water Subbasin Areas (Acres)															
			SDN-3A-O		SDN3-X		SDN4		SDN4-X		SDW-1A-I		SDW-1A-O		SDW-1B-I			
			Pervious	Effective Impervious	Pervious	Effective Impervious	Pervious	Effective Impervious	Pervious	Effective Impervious	Pervious	Effective Impervious	Pervious	Effective Impervious	Pervious	Effective Impervious		
TRANS M		0%	-	-	-	-	-	-	-	-	-	-	-	-	-	-	-	-
Qvr		0%	-	-	-	-	-	-	-	-	-	-	-	-	-	-	-	-
Qv1		0%	-	-	-	-	-	-	-	-	-	-	-	-	-	-	-	-
Qv1		0%	-	-	-	-	-	-	-	-	-	-	-	-	-	-	-	-
QW		0%	-	-	-	-	-	-	-	-	-	-	-	-	-	-	-	-
TIA		100%	-	-	-	-	-	-	-	-	-	-	-	-	-	-	-	-
Wetland		0%	0.19	0.57	-	-	-	-	-	-	-	-	-	-	-	-	-	-
Lake			-	-	-	-	-	-	-	-	-	-	-	-	-	-	-	-
Mck-df			-	-	-	-	-	-	-	-	-	-	-	-	-	-	-	-
Other			-	-	-	-	-	-	-	-	-	-	-	-	-	-	-	-
Basin total:			18.45	1.47	25.38	27.69	2.63	1.05	14.14	1.05	37.11	0.35	14.84	0.52	76.68	3.18		
PERLND areas:																		
(16) Till-Forest			-	0.65	-	-	-	-	2.76	-	24.10	-	-	-	-	53.06	-	-
(26) Till-Grass			-	6.94	-	24.49	-	-	1.22	-	-	-	-	-	-	-	-	-
(34) Outwash-Forest			8.09	12.20	-	3.20	-	-	10.16	-	12.68	-	12.21	-	20.31	-	-	-
(44) Outwash-Grass			10.18	5.01	-	-	-	-	-	-	0.33	-	2.63	-	3.31	-	-	-
(54) Wetland			0.19	0.57	-	-	-	-	14.14	-	37.11	-	14.84	-	76.68	-	-	-
subtotal:			18.45	25.38	-	27.69	2.63	1.05	14.14	1.05	37.11	0.35	14.84	0.52	76.68	3.18		
IMPLND areas:																		
EIA			-	-	-	-	-	-	-	-	-	-	-	-	-	-	-	-
Basin total:			19.92	1.47	-	30.32	2.63	1.05	15.18	1.05	37.47	0.35	15.36	0.52	79.86	3.18		
Percent Impervious			7.4%	0.0%	8.7%	8.7%	6.9%	6.9%	6.9%	6.9%	0.9%	0.9%	3.4%	3.4%	4.0%	4.0%		
NETWORK FACTORS																		
PERLND 16 (TF)			-	0.650	-	-	-	-	2.757	-	24.102	-	-	-	-	53.059	-	-
PERLND 26 (TG)			-	6.944	-	24.488	-	-	1.215	-	-	-	-	-	-	-	-	-
PERLND 34 (OF)			8.092	12.201	-	3.204	-	-	10.163	-	12.681	-	12.207	-	20.312	-	-	-
PERLND 44 (OG)			10.176	5.010	-	-	-	-	-	-	0.330	-	2.634	-	3.308	-	-	-
PERLND 54 (SA)			0.186	0.574	-	2.627	-	-	1.049	-	0.354	-	0.517	-	3.176	-	-	-
IMPLND 14 (EIA)			1.467	-	-	30.319	-	-	15.184	-	37.467	-	15.358	-	79.856	-	-	-
SUM			19.921	25.379	-	30.319	2.627	1.049	15.184	1.049	37.467	0.354	15.358	0.517	79.856	3.176		

Miller Creek Surface Water Subbasin Characteristics - 1994 (asins)

Land Use	Soil Type	% of total basin equal to EIA	Surface Water Subbasin Areas (Acres)														
			SDW-1B-O		IWS-MILLER		IWS-NCPS		IWS-NSMPS		Total		Percent of Total				
			Pervious	Effective Impervious	Pervious	Effective Impervious	Pervious	Effective Impervious	Pervious	Effective Impervious	Pervious	Effective Impervious	Pervious	Effective Impervious			
COMM	Qvr	85%	-	-	-	-	-	-	-	-	-	-	-	5.91	33.48	0.47%	2.69%
	Qvt	85%	-	-	-	-	-	-	-	-	-	-	-	0.46	2.60	0.04%	0.21%
	Qvt	85%	-	-	-	-	-	-	-	-	-	-	-	2.41	13.66	0.19%	1.10%
F	M	0%	-	-	-	-	-	-	-	-	-	-	-	1.32	-	0.11%	0.00%
	Qu	0%	-	-	-	-	-	-	-	-	-	-	-	0.77	-	0.06%	0.00%
	Qvr	0%	-	-	-	-	-	-	-	-	-	-	-	76.29	-	6.13%	0.00%
	Qvt	0%	-	-	-	-	-	-	-	-	-	-	-	9.76	-	0.78%	0.00%
	Qvt	0%	-	-	-	-	-	-	-	-	-	-	-	19.92	-	1.60%	0.00%
	Qw	0%	-	-	-	-	-	-	-	-	-	-	-	5.44	-	0.44%	0.00%
HD	Qvr	15%	0.89	0.16	-	-	-	-	-	-	-	-	-	85.38	16.83	7.66%	1.35%
	Qvt	15%	-	-	-	-	-	-	-	-	-	-	-	16.63	2.94	1.34%	0.24%
	Qvt	15%	4.21	0.74	-	-	-	-	-	-	-	-	-	77.96	13.76	6.26%	1.11%
	Qw	15%	-	-	-	-	-	-	-	-	-	-	-	0.92	0.16	0.07%	0.01%
LD	M	4%	-	-	-	-	-	-	-	-	-	-	-	0.16	0.01	0.01%	0.00%
	Qu	4%	-	-	-	-	-	-	-	-	-	-	-	0.01	0.00	0.00%	0.00%
	Qvr	4%	6.30	0.26	-	-	-	-	-	-	-	-	-	186.10	7.75	14.85%	0.62%
	Qvt	4%	-	-	-	-	-	-	-	-	-	-	-	9.45	0.39	0.76%	0.03%
	Qvt	4%	-	-	-	-	-	-	-	-	-	-	-	21.56	0.80	1.73%	0.07%
	Qw	4%	-	-	-	-	-	-	-	-	-	-	-	0.33	0.01	0.03%	0.00%
MF	Qvr	47%	-	-	-	-	-	-	-	-	-	-	-	34.37	30.48	2.76%	2.45%
	Qvt	47%	-	-	-	-	-	-	-	-	-	-	-	0.20	0.17	0.02%	0.01%
OG	M	0%	-	-	0.41	-	-	-	-	-	-	-	-	-	-	-	-
	Qvr	0%	-	8.54	-	-	-	-	1.73	-	-	-	-	-	11.61	-	0.93%
	Qvt	0%	-	-	-	-	-	-	1.86	-	-	-	-	-	131.15	-	10.53%
	Qvt	0%	-	3.85	-	-	-	-	-	-	-	-	-	0.00	-	0.00%	
	Qw	0%	-	-	-	-	-	-	-	-	-	-	-	126.20	-	10.14%	
	Qw	0%	-	-	-	-	-	-	-	-	-	-	-	8.59	-	0.69%	
STIA	M	0%	-	0.06	-	-	-	-	-	-	-	-	-	-	-	-	-
	Qvr	0%	-	0.08	-	-	-	-	1.97	-	-	-	-	-	50.81	-	4.08%
	Qvt	0%	-	0.33	-	-	-	-	1.02	-	-	-	-	-	2.17	-	0.17%
	Qw	0%	-	0.00	-	-	-	-	-	-	-	-	-	21.32	-	1.71%	
	TIA	100%	-	-	-	-	-	-	-	-	-	-	-	0.17	-	0.01%	
			-	30.41	-	-	-	-	-	-	-	-	-	-	57.71	-	0.00%
			-	-	28.79	-	-	-	-	-	-	-	-	-	-	-	4.64%

Table 1. Miller Creek Surface Water Subbasin Characteristics - 1994 (Sasins)

Land Use	Soil Type	% of total basin equal to EIA	Surface Water Subbasin Areas (Acres)										
			SDW-1B-O		IWS-MILLER		IWS-NCPS		IWS-NSMPS				
			Pervious	Effective Impervious	Pervious	Effective Impervious	Pervious	Effective Impervious	Pervious	Effective Impervious			
			Total		Total		Total		Total				
			Pervious	Effective Impervious	Pervious	Effective Impervious	Pervious	Effective Impervious	Pervious	Effective Impervious	Percent of Total		
TRANS	M	0%	-	-	-	-	-	-	-	-	-	0.07%	
	Qvr	0%	-	-	-	-	-	-	-	-	-	3.03%	
	Qvr1	0%	-	-	-	-	-	-	-	-	-	0.28%	
	Qw	0%	-	-	-	-	-	-	-	-	-	0.52%	
	TIA	100%	-	0.50	-	-	-	-	-	-	44.27	0.19%	
	Welland	0%	4.43	-	-	-	-	-	-	-	-	0.00%	
	Lake		-	-	-	-	-	-	-	-	-	4.15%	
	Mark-df		-	-	-	-	-	-	-	-	-	0.65%	
	Other		-	-	-	-	-	-	-	-	-	1.63%	
			-	-	-	-	-	-	-	-	-	0.00%	
Basin total:			15.84	1.16	12.86	30.92	6.93	28.79	6.58	0.04	1019.90	225.13	81.92%
PERLND areas:													
(16)	Till-Forest		-	-	-	-	-	-	-	-	31.00	-	2.41%
(26)	Till-Grass		4.21	-	4.23	-	6.93	-	3.71	-	353.76	-	27.45%
(34)	Outwash-Forest		-	-	-	-	-	-	-	-	77.06	-	5.98%
(54)	Outwash-Grass		7.20	-	8.62	-	-	-	2.88	-	501.42	-	38.91%
	Welland		4.43	-	0.00	-	-	-	-	-	69.52	-	5.39%
	subtotal:		15.84	-	12.86	-	6.93	-	6.58	-	1032.76	-	80.13%
IMPLND areas:													
EIA			-	1.16	-	30.92	-	28.79	-	0.04	-	256.05	-
Basin total:			17.00	1.16	43.78	30.92	35.71	28.79	6.63	0.7%	1288.81	256.05	100.00%
Percent Impervious			6.8%	70.6%	80.6%	80.6%	80.6%	80.6%	80.6%	0.7%	1288.81	256.05	100.00%
NETWORK FACTORS													
PERLND 16	(1F)		-	-	-	-	-	-	-	-	31.001	-	2.41%
PERLND 26	(1G)		4.214	-	4.230	-	6.928	-	3.705	-	353.755	-	27.45%
PERLND 34	(0F)		-	-	-	-	-	-	-	-	77.062	-	5.98%
PERLND 44	(0G)		7.198	-	8.625	-	-	-	2.877	-	501.422	-	38.91%
PERLND 54	(SA)		4.427	-	0.004	-	-	-	-	-	69.523	-	5.39%
IMPLND 14	(EIA)		1.164	-	30.917	-	28.787	-	0.044	-	256.046	-	19.87%
SUM			17.004	1.164	43.775	35.715	35.715	28.787	6.626	0.044	1288.809	256.046	100.00%

Table J. Miller Creek Surface Water Subbasin Characteristics - 2006 (5 basins)

Land Use	Soil Type	% of total basin equal to EIA	Surface Water Subbasin Areas (Acres)																
			M5		M6		M8		M9		M10		M16		MCI n				
			Pervious	Effective Impervious	Pervious	Effective Impervious	Pervious	Effective Impervious	Pervious	Effective Impervious	Pervious	Effective Impervious	Pervious	Effective Impervious	Pervious	Effective Impervious			
COMM	Qvr	85%	0.53	3.01	-	-	-	-	-	-	-	-	-	-	-	-	-	-	
	Qvrl	85%	-	-	-	-	-	-	-	-	-	-	-	-	-	-	-	-	
	Qvt	85%	2.18	12.34	0.08	0.44	-	-	-	-	-	-	-	-	0.02	0.12	0.46	2.60	
F	Fill	0%	-	-	-	-	-	-	-	-	-	-	-	-	-	-	-	-	
	M	0%	-	-	0.07	-	-	-	-	-	-	-	-	-	-	-	-	-	
	Qu	0%	-	-	-	-	-	-	-	-	-	-	-	-	-	-	-	-	
	Qvr	0%	-	-	13.44	-	-	-	-	-	-	-	-	-	1.17	-	-	-	
	Qvrl	0%	-	-	-	-	-	-	0.05	-	-	-	-	-	0.77	-	-	-	
	Qvt	0%	-	-	-	-	-	-	4.98	-	-	-	-	-	19.26	-	-	-	
	Qw	0%	-	-	1.35	-	-	-	4.98	-	-	-	-	-	9.76	-	-	-	
HD	Qvr	15%	-	-	-	-	-	-	-	-	-	-	-	-	-	-	-	-	
	Qvrl	15%	-	-	-	-	-	0.48	46.39	8.19	1.23	6.98	15.22	2.69	15.22	2.69	-	-	
	Qvt	15%	-	-	5.70	1.01	-	-	14.03	2.48	3.46	19.60	16.63	2.94	16.63	2.94	-	-	
LD	M	4%	-	-	-	-	-	-	-	-	-	-	-	-	0.15	0.01	-	-	
	Qu	4%	-	-	-	-	-	-	-	-	-	-	-	-	0.01	0.00	-	-	
	Qvr	4%	9.67	0.40	-	-	-	14.21	1.26	0.05	2.15	51.59	5.35	0.22	5.35	0.22	-	-	
	Qvrl	4%	-	-	-	-	-	-	-	-	-	-	-	-	8.95	0.37	-	-	
	Qvt	4%	-	-	-	-	-	-	-	-	-	8.02	-	-	-	-	-	-	
MF	Qvr	47%	0.62	0.55	-	-	-	-	5.13	4.55	17.71	19.97	1.19	1.06	1.19	1.06	-	-	
	Qvrl	47%	-	-	-	-	-	6.68	5.92	-	-	-	0.20	0.17	0.20	0.17	-	-	
OG	M	0%	-	-	0.21	-	-	-	-	-	-	-	-	-	-	-	-	-	
	Qvr	0%	39.23	-	8.34	-	-	0.84	0.10	-	-	-	2.82	-	2.82	-	0.04	-	
	Qvrl	0%	-	-	-	-	-	-	-	-	-	-	0.06	-	0.06	-	2.41	-	
	Qvt	0%	8.12	-	14.36	-	-	-	-	-	-	-	-	-	-	-	-	-	
	Qw	0%	0.47	-	-	-	-	-	-	-	-	-	-	-	-	-	-	-	
STIA	Fill	0%	-	-	-	-	-	-	-	-	-	-	-	-	-	-	-	-	
	M	0%	-	-	-	-	-	-	-	-	-	-	-	-	-	-	-	-	
	Qvr	0%	-	-	-	-	-	-	-	-	-	-	-	-	-	-	-	-	
	Qvrl	0%	-	-	-	-	-	-	-	-	-	-	-	-	-	-	-	-	
	Qvt	0%	-	-	-	-	-	-	-	-	-	-	-	-	-	-	-	-	
	Qw	0%	-	-	-	-	-	-	-	-	-	-	-	-	-	-	-	-	
	TIA	100%	-	-	-	-	0.00	-	-	-	-	-	-	-	-	-	-	-	
																			1.63

Table 1. Miller Creek Surface Water Subbasin Characteristics - 2006 (S asins)

Land Use	Soil Type	% of total basin equal to EIA	Surface Water Subbasin Areas (Acres)														
			M5		M6		M8		M9		M10		M16		MC1n		
			Pervious	Effective Impervious	Pervious	Effective Impervious	Pervious	Effective Impervious	Pervious	Effective Impervious	Pervious	Effective Impervious	Pervious	Effective Impervious	Pervious	Effective Impervious	
TRANS M		0%	-	0.03	-	-	-	-	-	-	-	-	-	-	-	0.10	-
Qvr		0%	-	3.45	-	-	-	-	3.83	-	11.33	-	-	-	7.22	3.84	-
Qvr1		0%	-	-	-	-	-	-	0.36	-	4.32	-	-	-	3.48	-	-
Qw		0%	-	-	-	-	-	-	0.01	-	-	-	-	-	-	-	-
TIA		100%	-	-	-	4.78	-	-	7.21	-	-	-	16.76	-	-	-	0.35
Welland		0%	10.27	0.80	-	-	-	-	-	-	-	-	-	-	-	0.27	-
Lake			0.44	-	-	-	-	-	-	-	-	-	-	-	-	-	-
Merk-df			-	0.07	-	-	-	-	-	-	-	-	-	-	-	-	-
Other			-	0.01	-	-	-	-	-	-	0.00	-	-	-	-	-	-
Basin total:			71.08	16.31	47.84	6.23	22.21	6.60	76.14	22.47	131.32	71.98	92.73	15.58	9.99	1.98	
PERLND areas:																	
(16) Till-Forest			-	1.42	-	-	-	-	4.98	-	4.15	-	10.93	-	-	-	-
(26) Till-Grass			10.29	20.38	-	-	-	-	14.38	-	31.94	-	29.93	-	0.14	-	-
(34) Outwash-Forest			-	13.44	-	-	-	-	0.05	-	-	-	20.03	-	-	-	-
(44) Outwash-Grass			50.05	11.79	-	-	22.21	-	56.71	-	95.22	-	31.83	-	9.44	-	-
(45) Fill			-	-	-	-	-	-	-	-	-	-	-	-	0.14	-	-
(54) Welland			10.74	0.82	-	-	-	-	0.01	-	-	-	-	-	0.27	-	-
subtotal:			71.08	47.84	-	-	22.21	-	76.14	-	131.32	-	92.73	-	9.99	-	-
IMPLND areas:																	
EIA			16.31	6.23	-	-	-	6.60	22.47	-	203.30	71.98	108.32	15.58	11.97	1.98	-
Basin total:			87.39	54.07	54.07	11.5%	28.80	22.9%	98.61	22.8%	203.30	35.4%	108.32	14.4%	11.97	15.6%	-
Percent Impervious			18.7%	11.5%	22.9%	22.8%	22.8%	22.9%	22.8%	22.8%	203.30	35.4%	108.32	14.4%	11.97	15.6%	-
NETWORK FACTORS																	
PERLND 16 (TF)			-	1.417	-	-	-	-	4.981	-	4.155	-	10.932	-	-	-	-
PERLND 26 (TG)			10.293	20.376	-	-	-	-	14.384	-	31.940	-	29.933	-	0.138	-	-
PERLND 34 (OF)			-	13.444	-	-	-	-	0.048	-	-	-	20.035	-	-	-	-
PERLND 44 (OG)			50.047	11.791	-	-	22.206	-	56.712	-	95.222	-	31.833	-	9.437	-	-
PERLND 45 (FL)			-	-	-	-	-	-	-	-	-	-	-	-	0.140	-	-
PERLND 54 (SA)			10.743	0.816	-	-	-	-	0.011	-	-	-	-	-	0.272	-	-
IMPLND 14 (EIA)			16.309	6.229	-	-	6.599	-	22.472	-	71.984	-	15.582	-	1.979	-	-
SUM			87.392	54.073	54.073	11.5%	28.804	22.9%	98.608	22.8%	203.300	35.4%	108.315	14.4%	11.966	15.6%	-

Table 1. Miller Creek Surface Water Subbasin Characteristics - 2006 (S. Basins)

		Surface Water Subbasin Areas (Acres)															
Land Use	Soil Type	% of total basin equal to EIA	MC2		MC3		MC4		MC5		MC6		MC7		CARGO		
			Pervious	Effective Impervious	Pervious	Effective Impervious	Pervious	Effective Impervious	Pervious	Effective Impervious	Pervious	Effective Impervious	Pervious	Effective Impervious	Pervious	Effective Impervious	
GOMM	Qvr	85%	-	-	-	-	-	-	-	-	-	-	-	-	-	-	-
	Qvr	85%	-	-	-	-	-	-	-	-	-	-	-	-	-	-	-
	Qvr	85%	-	-	-	-	-	-	-	-	-	-	-	-	-	-	-
F	Fill	0%	0.00	-	-	-	-	-	-	-	-	-	-	-	-	-	-
	M	0%	0.08	-	-	-	-	-	-	-	-	-	-	-	-	-	-
	Qu	0%	-	-	-	-	-	-	-	-	-	-	-	-	-	-	-
	Qvr	0%	3.60	3.70	0.27	-	-	-	-	-	-	-	-	-	-	-	-
	Qvr	0%	-	-	-	-	-	-	-	-	-	-	-	-	-	-	-
	Qvt	0%	-	-	-	-	-	-	-	-	-	-	-	-	-	-	-
	Qw	0%	4.23	1.20	0.35	-	-	-	-	-	-	-	-	-	-	-	-
HD	Qvr	15%	-	-	-	-	-	-	-	-	-	-	-	-	-	-	-
	Qvr	15%	-	-	-	-	-	-	-	-	-	-	-	-	-	-	-
	Qvt	15%	-	-	-	-	-	-	-	-	-	-	-	-	-	-	-
LD	M	4%	-	-	-	-	-	-	-	-	-	-	-	-	-	-	-
	Qu	4%	-	-	-	-	-	-	-	-	-	-	-	-	-	-	-
	Qvr	4%	-	-	-	-	-	-	-	-	-	-	-	-	-	-	-
	Qvr	4%	-	-	-	-	-	-	-	-	-	-	-	-	-	-	-
	Qvt	4%	-	-	-	-	-	-	-	-	-	-	-	-	-	-	-
	Qvt	4%	-	-	-	-	-	-	-	-	-	-	-	-	-	-	-
MF	Qvr	47%	-	-	-	-	-	-	-	-	-	-	-	-	-	-	-
	Qvh	47%	-	-	-	-	-	-	-	-	-	-	-	-	-	-	-
OG	M	0%	0.46	-	-	-	-	-	-	-	-	-	-	-	-	-	-
	Qvr	0%	3.57	2.99	13.36	33.42	-	-	-	-	-	-	-	-	-	-	-
	Qvr	0%	-	-	-	-	-	-	-	-	-	-	-	-	-	-	-
	Qvt	0%	-	-	-	-	-	-	-	-	-	-	-	-	-	-	-
	Qw	0%	0.49	-	6.36	13.43	-	-	-	-	-	-	-	-	-	-	-
STIA	Fill	0%	2.22	1.07	4.23	-	-	-	-	-	-	-	-	-	-	-	-
	M	0%	0.06	-	-	-	-	-	-	-	-	-	-	-	-	-	-
	Qvr	0%	3.08	0.59	3.16	0.42	-	-	-	-	-	-	-	-	-	-	-
	Qvt	0%	-	-	-	-	-	-	-	-	-	-	-	-	-	-	-
	Qw	0%	0.03	0.18	0.26	-	-	-	-	-	-	-	-	-	-	-	-
	TIA	100%	-	-	-	3.31	0.02	0.26	0.03	0.03	0.02	0.26	0.03	0.03	0.03	0.03	0.03

Miller Creek Surface Water Subbasin Characteristics - 2006 (S...asins)

Land Use	Soil Type	% of total basin equal to EIA	Surface Water Subbasin Areas (Acres)																
			MC2		MC3		MC4		MC5		MC6		MC7		CARGO				
			Pervious	Effective Impervious	Pervious	Effective Impervious	Pervious	Effective Impervious	Pervious	Effective Impervious	Pervious	Effective Impervious	Pervious	Effective Impervious	Pervious	Effective Impervious			
TRANS	M	0%	0.02	-	-	-	-	-	-	-	-	-	-	-	-	-	-	-	
	Qvr	0%	2.55	-	-	-	-	-	-	-	-	-	-	-	-	-	-	-	
	Qvr1	0%	-	1.32	-	-	-	-	-	-	-	-	-	-	-	-	-	-	
	Qvr1	0%	-	-	-	-	-	-	-	-	-	-	-	-	-	-	-	-	
	Qw	0%	0.22	-	-	-	-	-	-	-	-	-	-	-	-	-	-	-	
	TIA	100%	-	0.43	-	-	-	-	-	-	-	-	-	-	-	-	-	-	
			-	0.27	0.01	-	-	-	-	-	-	-	-	-	-	-	-	-	
	Wetland	0%	10.16	-	0.04	-	-	5.02	-	7.44	-	-	-	0.90	-	-	-	-	
	Lake		2.98	-	-	-	3.30	-	-	0.73	-	-	-	0.29	-	-	-	-	
	Mark-df		7.00	-	13.17	-	-	-	-	-	-	-	-	-	-	-	-	-	
	Other		-	-	-	-	-	-	-	-	-	-	-	-	-	-	-	-	
Basin total:			30.77	2.54	11.52	1.42	33.00	3.31	54.71	0.02	15.09	0.26	46.26	0.03	-	-	-	8.12	
PERLND areas:																			
(18)	Till-Forest		0.08	-	-	-	-	-	-	-	-	-	-	-	-	-	-	-	-
(26)	Till-Grass		0.53	-	-	-	-	-	-	-	-	-	-	-	-	-	-	-	-
(34)	Outwash-Forest		3.60	3.70	-	-	0.27	-	13.43	-	-	-	-	-	-	-	-	-	-
(44)	Outwash-Grass		9.20	4.91	-	-	16.51	-	33.84	-	-	-	-	-	-	-	-	-	-
(45)	Fill		2.22	1.07	-	-	4.23	-	7.44	-	-	-	-	-	-	-	-	-	-
(54)	Wetland		15.14	1.84	-	-	11.98	-	54.71	-	-	-	-	-	-	-	-	-	-
IMPLND areas:			30.77	11.52	-	-	33.00	-	54.71	0.02	15.09	0.26	46.26	0.03	-	-	-	-	-
EIA																			
Basin total:			33.31	2.54	12.94	1.42	36.31	3.31	54.74	0.02	15.35	0.26	46.29	0.03	-	-	-	8.12	
Percent Impervious			7.6%	11.0%	9.1%	1.7%	0.0%	0.1%	100.0%										
NETWORK FACTORS																			
PERLND 16	(TF)		0.078	-	-	-	-	-	13.432	-	-	-	-	-	-	-	-	-	-
PERLND 26	(TG)		0.531	-	-	-	-	-	33.842	-	-	-	-	-	-	-	-	-	-
PERLND 34	(OF)		3.598	3.701	-	-	0.274	-	7.438	-	-	-	-	-	-	-	-	-	-
PERLND 44	(OG)		9.205	4.910	-	-	16.514	-	0.025	-	-	-	-	-	-	-	-	-	-
PERLND 45	(FL)		2.221	1.070	-	-	4.230	-	0.092	-	-	-	-	-	-	-	-	-	-
PERLND 54	(SA)		15.139	1.843	-	-	11.979	-	0.260	-	-	-	-	-	-	-	-	-	-
IMPLND 14	(EIA)		2.538	1.419	-	-	3.311	-	0.032	-	-	-	-	-	-	-	-	-	-
SUM			33.311	12.943	36.309	54.738	46.288	8.117	46.288	8.117									

Table J. Miller Creek Surface Water Subbasin Characteristics - 2006 (S basins)

Land Use	Soil Type	% of total basin equal to EIA	Surface Water Subbasin Areas (Acres)												
			NEPL Pervious	NEPL Effective	SDN1 Pervious	SDN1 Effective	SDN1-LWR Pervious	SDN1-LWR Effective	SDN1-OFF Pervious	SDN1-OFF Effective	SDN2-Xn Pervious	SDN2-Xn Effective	SDN3 Pervious	SDN3 Effective	SDN-3A-1 Pervious
COMM	Qvr	85%	-	-	-	-	-	-	-	-	-	-	-	-	-
	Qvr1	85%	-	-	-	-	-	-	-	-	-	-	-	-	-
	Qvt	85%	-	-	-	-	-	-	-	-	-	-	-	-	-
F	Fill	0%	-	-	-	-	-	-	-	-	-	-	-	-	-
	M	0%	-	-	-	-	-	-	-	-	-	-	-	-	-
	Qu	0%	-	-	-	-	-	-	-	-	-	-	-	-	-
	Qvr	0%	-	-	-	-	-	-	-	-	-	-	-	-	-
	Qvr1	0%	-	-	-	-	-	-	-	-	-	-	-	-	-
	Qvt	0%	-	-	-	-	-	-	-	-	-	-	-	-	-
	Qw	0%	-	-	-	-	-	-	-	-	-	-	-	-	-
HD	Qvr	15%	-	-	-	-	-	-	-	-	-	-	-	-	-
	Qvr1	15%	-	-	-	-	-	-	-	-	-	-	-	-	-
	Qvt	15%	-	-	-	-	-	0.70	0.12	-	-	-	-	-	-
LD	M	4%	-	-	-	-	-	-	-	-	-	-	-	-	-
	Qu	4%	-	-	-	-	-	-	-	-	-	-	-	-	-
	Qvr	4%	-	-	-	-	-	-	-	-	-	-	-	-	-
	Qvr1	4%	-	-	-	-	-	-	-	-	-	-	-	-	-
	Qvt	4%	-	-	-	-	-	-	-	-	-	-	-	-	-
MF	Qvr	47%	-	-	-	-	-	-	-	-	-	-	-	-	-
	Qvr1	47%	-	-	-	-	-	-	-	-	-	-	-	-	-
OG	M	0%	-	-	-	-	-	-	-	-	-	-	-	-	-
	Qvr	0%	-	-	-	-	-	-	0.00	-	-	-	-	-	-
	Qvr1	0%	-	-	-	-	-	-	0.30	-	-	-	-	-	-
	Qvt	0%	-	-	-	-	-	-	19.87	-	-	-	-	-	-
	Qw	0%	-	-	-	-	-	-	-	-	-	-	-	-	-
STIA	Fill	0%	-	-	-	-	-	-	-	-	-	-	-	-	-
	M	0%	-	-	-	-	-	-	-	-	-	-	-	-	-
	Qvr	0%	-	-	-	-	-	-	-	-	-	-	-	-	-
	Qvt	0%	-	-	-	-	-	-	-	-	-	-	-	-	-
	Qw	0%	-	-	-	-	-	-	-	-	-	-	-	-	-
	TIA	100%	-	-	-	-	-	-	-	-	-	-	-	-	-
			42.29	11.46	0.19	0.36	24.30	5.87							

Table 1. Miller Creek Surface Water Subbasin Characteristics - 2006 (S jasins)

Land Use	Soil Type	% of total basin equal to EIA	Surface Water Subbasin Areas (Acres)													
			NEPL		SDN1		SDN1-LWR		SDN1-OFF		SDN2-Xn		SDN3		SDN-3A-1	
			Pervious	Effective Impervious	Pervious	Effective Impervious	Pervious	Effective Impervious	Pervious	Effective Impervious	Pervious	Effective Impervious	Pervious	Effective Impervious	Pervious	Effective Impervious
TRANS	M	0%	-	-	-	-	-	-	-	-	-	-	-	-	-	-
	Qvr	0%	-	-	-	-	-	-	-	-	-	-	-	-	-	-
	Qvrl	0%	-	-	-	-	-	-	-	-	-	-	-	-	-	-
	Qw	0%	-	-	-	-	-	-	-	-	-	-	-	-	-	-
	TIA	100%	-	-	-	-	-	-	-	-	-	-	-	-	-	-
	Wetland	0%	-	-	-	-	-	-	-	-	-	-	-	-	-	-
	Lake		-	-	-	-	-	-	-	-	-	-	-	-	-	-
	Crk-df		-	-	-	-	-	-	-	-	-	-	-	-	-	-
	Other		-	-	-	-	-	-	-	-	-	-	-	-	-	-
Basin total:																
PERLND areas:																
(16)	Till-Forest		-	-	-	-	-	-	-	-	-	-	-	-	-	-
(26)	Till-Grass		10.00	-	-	-	-	-	-	-	-	-	-	-	-	-
(34)	Outwash-Forest		-	-	-	-	-	-	-	-	-	-	-	-	-	-
(44)	Outwash-Grass		-	-	-	-	-	-	-	-	-	-	-	-	-	-
(45)	Fill		-	-	-	-	-	-	-	-	-	-	-	-	-	-
(54)	Welland		-	-	-	-	-	-	-	-	-	-	-	-	-	-
	subtotal:		10.00	-	-	-	-	-	-	-	-	-	-	-	-	-
IMPLND areas:																
	EIA		-	-	-	-	-	-	-	-	-	-	-	-	-	-
Basin total:			42.29	32.29	16.14	12.68	5.42	5.42	36.27	4.26	47.86	24.30	10.52	55.7%		
Percent Impervious			76.4%	78.6%	10.4%	22.1%	8.5%	50.8%	55.7%							
NETWORK FACTORS																
PERLND 16	(TF)		-	-	-	-	-	-	-	-	-	-	-	-	-	-
PERLND 26	(TG)		10.000	1.968	-	-	-	-	23.013	0.632	23.556	0.077	-	-	-	-
PERLND 34	(OF)		-	-	-	-	-	-	-	-	-	-	-	-	-	-
PERLND 44	(OG)		-	-	-	-	-	-	-	-	-	-	-	-	-	-
PERLND 45	(FL)		-	-	-	-	-	-	-	-	-	-	-	-	-	-
PERLND 54	(SA)		-	-	-	-	-	-	-	-	-	-	-	-	-	-
IMPLND 14	(EIA)		32.291	0.200	12.682	0.071	0.565	8.000	36.269	0.363	24.300	5.866	10.524	55.7%		
SUM			42.291	16.139	16.139	5.423	5.423	36.269	47.856	4.260	47.856	10.524	55.7%			

Miller Creek Surface Water Subbasin Characteristics - 2006 (Acras)

Land Use	Soil Type	% of total basin equal to EIA	Surface Water Subbasin Areas (Acras)																																										
			SDN-3A-O		SDN3-X		SDN4		SDN4-X		SDW-1A-I		SDW-1A-O		SDW-1B-I																														
			Pervious	Effective Impervious	Pervious	Effective Impervious	Pervious	Effective Impervious	Pervious	Effective Impervious	Pervious	Effective Impervious	Pervious	Effective Impervious	Pervious	Effective Impervious																													
COMM	Qvr Qvt Qvt	85% 85% 85%	-	-	-	-	-	-	-	-	-	-	-	-	-	-	-	-	-	-	-	-	-	-	-	-	-	-	-	-	-	-	-	-	-	-	-	-	-						
F	Fill M Qu Qvr Qvt Qvt Qw	0% 0% 0% 0% 0% 0%	-	-	-	-	-	-	-	-	-	-	-	-	-	-	-	-	-	-	-	-	-	-	-	-	-	-	-	-	-	-	-	-	-	-	-	-	-	-	-				
HD	Qvr Qvt Qvt	15% 15% 15%	-	-	-	-	-	-	-	-	-	-	-	-	-	-	-	-	-	-	-	-	-	-	-	-	-	-	-	-	-	-	-	-	-	-	-	-	-	-	-				
LD	M Qu Qvr Qvt Qvt	4% 4% 4% 4% 4%	-	-	-	-	-	-	-	-	-	-	-	-	-	-	-	-	-	-	-	-	-	-	-	-	-	-	-	-	-	-	-	-	-	-	-	-	-	-	-				
MF	Qvr Qvt	47% 47%	-	-	-	-	-	-	-	-	-	-	-	-	-	-	-	-	-	-	-	-	-	-	-	-	-	-	-	-	-	-	-	-	-	-	-	-	-	-	-	-			
OG	M Qvr Qvt Qvt Qw	0% 0% 0% 0% 0%	-	-	-	-	-	-	-	-	-	-	-	-	-	-	-	-	-	-	-	-	-	-	-	-	-	-	-	-	-	-	-	-	-	-	-	-	-	-	-	-	-		
STIA	Fill M Qvr Qvt Qw TIA	0% 0% 0% 0% 0% 100%	17.54	-	23.77	-	0.99	0.99	8.31	19.41	13.03	35.97	-	-	-	-	-	-	-	-	-	-	-	-	-	-	-	-	-	-	-	-	-	-	-	-	-	-	-	-	-	-	-	-	
			0.03	-	-	15.69	15.69	1.35	1.35	-	-	11.17	-	-	-	-	-	-	-	-	-	-	-	-	-	-	-	-	-	-	-	-	-	-	-	-	-	-	-	-	-	-	-	-	
			-	-	1.61	-	1.31	1.31	0.75	4.28	0.69	9.20	-	-	-	-	-	-	-	-	-	-	-	-	-	-	-	-	-	-	-	-	-	-	-	-	-	-	-	-	-	-	-	-	
			-	-	-	-	0.06	0.06	0.57	-	-	-	-	-	-	-	-	-	-	-	-	-	-	-	-	-	-	-	-	-	-	-	-	-	-	-	-	-	-	-	-	-	-	-	
			-	-	-	2.35	-	12.26	-	-	-	-	-	-	-	-	-	-	-	-	-	-	-	-	-	-	-	-	-	-	-	-	-	-	-	-	-	-	-	-	-	-	-	-	
			-	-	-	0.00	-	-	-	-	-	-	-	-	-	-	-	-	-	-	-	-	-	-	-	-	-	-	-	-	-	-	-	-	-	-	-	-	-	-	-	-	-	-	
			-	-	-	-	-	-	-	-	-	-	-	-	-	-	-	-	-	-	-	-	-	-	-	-	-	-	-	-	-	-	-	-	-	-	-	-	-	-	-	-	-	-	-
			-	-	-	-	-	-	-	-	-	-	-	-	-	-	-	-	-	-	-	-	-	-	-	-	-	-	-	-	-	-	-	-	-	-	-	-	-	-	-	-	-	-	-
			-	-	-	-	-	-	-	-	-	-	-	-	-	-	-	-	-	-	-	-	-	-	-	-	-	-	-	-	-	-	-	-	-	-	-	-	-	-	-	-	-	-	-
			-	-	-	-	-	-	-	-	-	-	-	-	-	-	-	-	-	-	-	-	-	-	-	-	-	-	-	-	-	-	-	-	-	-	-	-	-	-	-	-	-	-	-
			-	-	-	-	-	-	-	-	-	-	-	-	-	-	-	-	-	-	-	-	-	-	-	-	-	-	-	-	-	-	-	-	-	-	-	-	-	-	-	-	-	-	-
			-	-	-	-	-	-	-	-	-	-	-	-	-	-	-	-	-	-	-	-	-	-	-	-	-	-	-	-	-	-	-	-	-	-	-	-	-	-	-	-	-	-	-
			-	-	-	-	-	-	-	-	-	-	-	-	-	-	-	-	-	-	-	-	-	-	-	-	-	-	-	-	-	-	-	-	-	-	-	-	-	-	-	-	-	-	-
			-	-	-	-	-	-	-	-	-	-	-	-	-	-	-	-	-	-	-	-	-	-	-	-	-	-	-	-	-	-	-	-	-	-	-	-	-	-	-	-	-	-	-
			-	-	-	-	-	-	-	-	-	-	-	-	-	-	-	-	-	-	-	-	-	-	-	-	-	-	-	-	-	-	-	-	-	-	-	-	-	-	-	-	-	-	-
			-	-	-	-	-	-	-	-	-	-	-	-	-	-	-	-	-	-	-	-	-	-	-	-	-	-	-	-	-	-	-	-	-	-	-	-	-	-	-	-	-	-	-
			-	-	-	-	-	-	-	-	-	-	-	-	-	-	-	-	-	-	-	-	-	-	-	-	-	-	-	-	-	-	-	-	-	-	-	-	-	-	-	-	-	-	-
			-	-	-	-	-	-	-	-	-	-	-	-	-	-	-	-	-	-	-	-	-	-	-	-	-	-	-	-	-	-	-	-	-	-	-	-	-	-	-	-	-	-	-
			-	-	-	-	-	-	-	-	-	-	-	-	-	-	-	-	-	-	-	-	-	-	-	-	-	-	-	-	-	-	-	-	-	-	-	-	-	-	-	-	-	-	-
			-	-	-	-	-	-	-	-	-	-	-	-	-	-	-	-	-	-	-	-	-	-	-	-	-	-	-	-	-	-	-	-	-	-	-	-	-	-	-	-	-	-	-
			-	-	-	-	-	-	-	-	-	-	-	-	-	-	-	-	-	-	-	-	-	-	-	-	-	-	-	-	-	-	-	-	-	-	-	-	-	-	-	-	-	-	-
			-	-	-	-	-	-	-	-	-	-	-	-	-	-	-	-	-	-	-	-	-	-	-	-	-	-	-	-	-	-	-	-	-	-	-	-	-	-	-	-	-	-	-
			-	-	-	-	-	-	-	-	-	-	-	-	-	-	-	-	-	-	-	-	-	-	-	-	-	-	-	-	-	-	-	-	-	-	-	-	-	-	-	-	-	-	-
			-	-	-	-	-	-	-	-	-	-	-	-	-	-	-	-	-	-	-	-	-	-	-	-	-	-	-	-	-	-	-	-	-	-	-	-	-	-	-	-	-	-	-
			-	-	-	-	-	-	-	-	-	-	-	-	-	-	-	-	-	-	-	-	-	-	-	-	-	-	-	-	-	-	-	-	-	-	-	-	-	-	-	-	-	-	-
			-	-	-	-	-	-	-	-	-	-	-	-	-	-	-	-	-	-	-	-	-	-	-	-	-	-	-	-	-	-	-	-	-	-	-	-	-	-	-	-	-	-	

Table 1 Miller Creek Surface Water Subbasin Characteristics - 2006 (asins)

Land Use	Soil Type	Surface Water Subbasin Areas (Acres)															
		SDN-3A-O		SDN3-X		SDN4		SDN4-X		SDW-1A-I		SDW-1A-O		SDW-1B-I			
		Pervious	Effective Impervious	Pervious	Effective Impervious	Pervious	Effective Impervious	Pervious	Effective Impervious	Pervious	Effective Impervious	Pervious	Effective Impervious	Pervious	Effective Impervious		
TRANS M	0%	-	-	-	-	-	-	-	-	-	-	-	-	-	-	-	-
Cvr	0%	-	-	-	-	-	-	-	-	-	-	-	-	-	-	-	-
Cvrl	0%	-	-	-	-	-	-	-	-	-	-	-	-	-	-	-	-
Cvl	0%	-	-	-	-	-	-	-	-	-	-	-	-	-	-	-	-
Cw	0%	-	-	-	-	-	-	-	-	-	-	-	-	-	-	-	-
TIA	100%	-	-	-	-	-	-	-	-	-	-	-	-	-	-	-	-
Wetland	0%	-	-	-	-	-	-	-	-	-	-	-	-	-	-	-	-
Lake		-	-	-	-	-	-	-	-	-	-	-	-	-	-	-	-
Mark-df		-	-	-	-	-	-	-	-	-	-	-	-	-	-	-	-
Other		-	-	-	-	-	-	-	-	-	-	-	-	-	-	-	-
Basin total:		17.67	2.35	25.38	0.00	18.06	12.26	10.97	4.21	23.69	13.78	13.72	1.64	56.33	23.52		
PERLND areas:																	
(16) Till-Forest		-	-	1.61	-	15.75	-	1.92	-	4.28	-	-	-	-	-	20.37	-
(26) Till-Grass		-	-	-	-	1.31	-	0.75	-	-	-	0.69	-	-	-	-	-
(34) Outwash-Forest		0.03	-	23.77	-	0.99	-	8.31	-	19.41	-	13.03	-	-	-	35.97	-
(44) Outwash-Grass		17.54	-	-	-	18.06	-	10.97	-	23.69	-	13.72	-	-	-	-	-
(45) FHI		-	-	-	-	-	-	-	-	-	-	-	-	-	-	-	-
(64) Wetland		17.57	-	25.38	-	-	-	-	-	-	-	-	-	-	-	-	-
IMPLND areas:																	
EIA																	
Basin total:		19.92	2.35	25.38	0.00	30.32	12.26	15.18	4.21	37.47	13.78	15.36	1.64	79.86	23.52		
Percent Impervious		11.8%		0.0%		40.4%		27.7%		36.8%		10.7%					
NETWORK FACTORS																	
PERLND 16 (TF)		-	-	1.613	-	15.755	-	1.916	-	4.278	-	-	-	-	-	20.365	-
PERLND 26 (TG)		-	-	-	-	1.309	-	0.750	-	-	-	0.688	-	-	-	-	-
PERLND 34 (OF)		0.032	-	23.766	-	0.992	-	8.305	-	19.412	-	13.031	-	-	-	35.966	-
PERLND 44 (OG)		17.537	-	-	-	-	-	-	-	-	-	-	-	-	-	-	-
PERLND 45 (FL)		-	-	-	-	-	-	-	-	-	-	-	-	-	-	-	-
PERLND 54 (SA)		2.352	-	0.000	-	12.263	-	4.213	-	13.777	-	1.639	-	-	-	23.525	-
IMPLND 14 (EIA)		19.921	-	25.379	-	30.319	-	15.184	-	37.467	-	15.358	-	-	-	79.856	-
SUM																	

Miller Creek Surface Water Subbasin Characteristics - 2006 (P. asins)

Land Use	Soil Type	% of total basin equal to EIA	Surface Water Subbasin Areas (Acres)											
			SDW-IB-O		IWS-NCPS		IWS-NSMPS		Total		Percent of Total			
			Pervious	Effective Impervious	Pervious	Effective Impervious	Pervious	Effective Impervious	Pervious	Effective Impervious	Pervious	Effective Impervious		
GOMM	Qvr Qvt Qvt	85% 85% 85%	- - -	- - -	- - -	- - -	- - -	5.91 0.46 2.26	33.48 2.60 12.78	0.47% 0.04% 0.18%	2.69% 0.21% 1.03%			
F	Fill M Qu Qvr Qvt Qvt Qw	0% 0% 0% 0% 0% 0%	- - - - - -	- - - - - -	- - - - - -	- - - - - -	0.00 1.32 0.77 40.33 9.76 10.49 5.78	- - - - - -	- - - - - -	0.00% 0.11% 0.06% 3.24% 0.78% 0.84% 0.46%	0.00% 0.00% 0.00% 0.00% 0.00% 0.00%			
HD	Qvr Qvt Qvt	15% 15% 15%	- - -	- - -	- - -	- - -	69.07 16.63 40.03	12.19 2.94 7.06	5.55% 1.34% 3.22%	0.98% 0.24% 0.57%				
LD	M Qu Qvr Qvt Qvt	4% 4% 4% 4% 4%	- - - - -	- - - - -	- - - - -	- - - - -	0.15 0.01 82.07 8.95 8.02	0.01 0.00 3.42 0.37 0.33	0.01% 0.00% 6.59% 0.72% 0.64%	0.00% 0.00% 0.27% 0.03% 0.03%				
MF	Qvr Qvt	47% 47%	- -	- -	- -	- -	33.59 0.20	29.78 0.17	2.70% 0.02%	2.39% 0.01%				
OG	M Qvr Qvt Qvt Qw	0% 0% 0% 0% 0%	- - - - -	- - - - -	- - - - -	- - - - -	0.70 146.18 0.13 63.80 7.32	- - - - -	0.06% 11.74% 0.01% 5.12% 0.59%	0.00% 0.00% 0.00% 0.00% 0.00%				
STIA	Fill M Qvr Qvt Qw TIA	0% 0% 0% 0% 0% 100%	10.30 - 2.39 0.89 -	- - - - -	4.78 - - - -	- - - - -	0.01 2.69 1.97 -	- - - -	11.45% 3.30% 2.59% 3.26% 0.05% 0.00%	0.00% 0.00% 0.00% 0.00% 0.00% 15.71%				
											195.61			

Table 1. Miller Creek Surface Water Subbasin Characteristics - 2006 (S jasins)

Land Use	Soil Type	% of total basin equal to EIA	Surface Water Subbasin Areas (Acres)											
			SDW-1B-O		IWS-NCPS		IWS-NSMPS		Total					
			Pervious	Effective Impervious	Pervious	Effective Impervious	Pervious	Effective Impervious	Pervious	Effective Impervious				
TRANS M		0%	-	-	-	-	-	-	-	0.83	-	-	0.07%	0.00%
		0%	-	-	-	-	-	-	-	37.72	-	-	3.03%	0.00%
		0%	-	-	-	-	-	-	-	3.48	-	-	0.28%	0.00%
		0%	-	-	-	-	-	-	-	6.43	-	-	0.52%	0.00%
		0%	-	-	-	-	-	-	-	2.33	-	-	0.18%	0.00%
		100%	-	-	-	-	-	-	-	-	44.25	-	0.00%	3.55%
Wetland		0%	0.00	-	-	-	-	-	-	38.22	-	-	3.07%	-
Lake		-	-	-	-	-	-	-	-	7.98	-	-	0.64%	-
Mark-df		-	-	-	-	-	-	-	-	20.24	-	-	1.63%	-
Other		-	-	-	-	-	-	-	-	0.04	-	-	0.00%	-
Basin total:			13.58	3.42	4.78	30.93	4.67	1.95	900.10	345.00			72.28%	27.71%
PERLND areas:														
(16) Till-Forest		-	-	-	-	-	-	-	-	21.56	-	-	1.73%	-
(26) Till-Grass		0.88	-	4.78	-	-	2.69	-	243.82	41.10	-	-	19.58%	-
(34) Outwash-Forest		-	-	-	-	-	-	-	406.82	142.51	-	-	32.67%	-
(44) Outwash-Grass		2.39	-	-	-	-	1.97	-	54.29	910.10	-	-	4.36%	-
(45) Fill		10.30	-	-	-	-	0.01	-	-	-	-	-	73.09%	-
(54) Wetland		0.00	-	-	-	-	-	-	-	-	-	-	-	-
subtotal:		13.58	-	4.78	-	-	4.67	-	-	-	-	-	-	-
IMPLND areas:														
EIA		-	3.42	-	30.93	1.95	-	-	335.00	-	-	-	-	26.91%
Basin total:		17.00	35.71	86.6%	6.63	29.5%	1245.11	100.00%						
Percent impervious		20.1%												
NETWORK FACTORS														
PERLND 16 (TF)		-	-	-	-	-	-	-	21.562	-	-	-	1.73%	-
PERLND 26 (TG)		0.888	-	4.781	-	-	2.686	-	243.817	41.101	-	-	19.58%	-
PERLND 34 (OF)		-	-	-	-	-	-	-	406.822	142.514	-	-	32.67%	-
PERLND 44 (OG)		2.392	-	-	-	-	1.975	-	54.289	335.002	-	-	4.36%	-
PERLND 45 (FL)		10.298	-	-	-	-	0.012	-	-	-	-	-	73.09%	-
PERLND 54 (SA)		0.005	-	-	-	-	-	-	-	-	-	-	-	-
IMPLND 14 (EIA)		3.421	30.934	1.954	6.626				1245.106				26.91%	
SUM		17.004	35.715	86.6%	6.626	29.5%	1245.106	100.00%						

Table 1. Miller Creek Contiguous Groundwater Subbasin Characteristic, 1994 (STIA basins)

Land Use	Soil Type	% of total basin equal to EIA	SDS3A		IWS PRIMARY		CARGO		M10		M16		M5		M6	
			Pervious	Effective Impervious	Pervious	Effective Impervious	Pervious	Effective Impervious	Pervious	Effective Impervious	Pervious	Effective Impervious	Pervious	Effective Impervious	Pervious	Effective Impervious
PERLND areas:																
(16) Till-Forest			2.15		0.06		7.04		4.15		10.93		10.29		1.43	
(26) Till-Grass			-		-		-		31.94		30.30		-		20.37	
(34) Outwash-Forest			-		-		-		-		20.03		-		13.43	
(44) Outwash-Grass			-		-		-		95.23		31.43		50.05		11.79	
(54) Wetland			-		-		-		-		-		10.74		0.82	
IMPLND areas:			2.15		0.06		7.04		131.32		92.69		71.08		47.84	
EIA			0.28		6.30		1.07		71.98		15.62		16.31		6.23	
Basin total:			2.43		6.36		8.12		203.30		108.31		87.39		54.07	
Percent impervious			11.5%		99.1%		13.2%		35.4%		14.4%		18.7%		11.5%	
NETWORK FACTORS																
PERLND 16 (TF)			-		-		-		4.155		10.992		-		1.435	
PERLND 26 (TG)			2.148		0.056		7.043		31.943		30.302		10.293		20.373	
PERLND 34 (OF)			-		-		-		-		20.035		-		13.426	
PERLND 44 (OG)			-		-		-		95.227		31.426		50.047		11.790	
PERLND 54 (SA)			-		-		-		-		-		10.742		0.816	
IMPLND 14 (EIA)			0.279		6.300		1.074		71.975		15.619		16.310		6.233	
SUM			2.427		6.357		8.117		203.300		108.313		87.392		54.073	

Table 1. Miller Creek Contiguous Groundwater Subbasin Characteristics, 1994 (STIA basins)

Land Use	Soil Type	% of total basin equal to EIA	MB		MC In		MC2		MC3		MC4		MC5	
			Effective Pervious	Effective Impervious	Effective Pervious	Effective Impervious	Effective Pervious	Effective Impervious	Effective Pervious	Effective Impervious	Effective Pervious	Effective Impervious	Effective Pervious	Effective Impervious
PERLND areas:														
(16) Tll-Forest			4.98		0.17		0.08							
(26) Tll-Grass			14.38				0.64							
(34) Outwash-Forest		22.21	0.05				6.66		5.53		0.05			13.49
(44) Outwash-Grass			56.71		11.15		10.41		5.03		19.47			31.13
(54) Wetland			0.01		0.27		15.25		2.27		14.70			7.60
IMPLND areas:		22.21	76.14		11.60		33.04		12.83		34.22			52.21
EIA		6.60			0.37		0.27		0.11		2.04			2.50
Basin total:		28.80	98.61		11.97		33.31		12.94		36.26			54.71
Percent Impervious		22.9%			3.1%		0.8%		0.9%		5.6%			4.6%
NETWORK FACTORS			MB		MC In		MC2		MC3		MC4		MC5	
PERLND 16 (TF)			4.981				0.078							
PERLND 26 (TG)			14.384		0.173		0.635							13.487
PERLND 34 (OF)			0.048				6.663		5.525		0.049			
PERLND 44 (OG)		22.206	56.712		11.151		10.414		5.033		19.470			31.127
PERLND 54 (SA)			0.011		0.272		15.250		2.273		14.700			7.596
IMPLND 14 (EIA)		6.598	22.472		0.369		0.270		0.112		2.043			2.503
SUM		28.804	98.608		11.966		33.311		12.943		36.263			54.714

Miller Creek Contiguous Groundwater Subbasin Characterization 994 (STIA basins)

Land Use	Soil Type	% of total basin equal to EIA	MCC6		MCC7		NEPL		SDN1		SDN1-LWR		SDN1-OFF		SDN2-Xn	
			Pervious	Impervious	Pervious	Impervious	Effective Pervious	Effective Impervious	Pervious	Impervious	Effective Pervious	Effective Impervious	Pervious	Impervious	Effective Pervious	Effective Impervious
PERLND areas:																
(16) Till-Forest																
(26) Till-Grass																
(34) Outwash-Forest																
(44) Outwash-Grass			13.56													
(54) Wetland			0.99													
subtotal:			14.55													
IMPLND areas:																
EIA				0.80												
Basin total:			15.35	46.29	3.05	42.29	0.87	7.48	3.77	5.42	20.32	5.85	4.26			
Percent Impervious																
			5.2%	6.6%	2.1%	2.1%	50.4%	7.0%	28.8%							
NETWORK FACTORS																
PERLND 16 (TF)																
PERLND 26 (TG)																
PERLND 34 (OF)																
PERLND 44 (OG)			13.561													
PERLND 54 (SA)			0.987													
IMPLND 14 (EIA)			0.799													
SUM			15.347	46.288	3.052	42.291	0.873	7.478	3.766	5.423	20.316	5.851	4.260			

Miller Creek Contiguous Groundwater Subbasin Characterization 994 (STIA basins)

Land Use	Soil Type	% of total basin equal to EIA	Groundwater Subbasin Areas (Acres)											
			SDN3-A-1		SDN3-A-O		SDN3-X		SDN4		SDN4-X		SDW1-A-1	
			Pervious	Effective Impervious	Pervious	Effective Impervious	Pervious	Effective Impervious	Pervious	Effective Impervious	Pervious	Effective Impervious	Pervious	Effective Impervious
PERLND areas:														
(16)	Till-Forest		-	5.27	-	1.47	0.65	6.94	24.49	2.76	1.05	24.10	2.76	1.05
(26)	Till-Grass	33.36	-	1.03	-	6.94	12.20	8.09	-	1.22	-	24.10	1.22	-
(34)	Outwash-Forest	-	-	3.82	10.18	5.01	10.18	3.20	3.20	10.16	12.68	12.68	10.16	12.68
(44)	Outwash-Grass	-	-	-	0.19	0.57	0.19	-	-	-	0.33	0.33	-	0.33
(54)	Welland	-	-	10.13	18.45	25.38	18.45	27.69	27.69	14.14	37.11	37.11	14.14	37.11
IMPLND areas:														
	EIA	14.50	-	0.40	1.47	0.40	1.47	-	2.63	-	1.05	0.35	-	0.35
Basin total:			47.86	10.52	19.92	25.38	30.32	30.32	30.32	15.18	15.18	37.47	15.18	15.18
Percent Impervious			30.3%	3.8%	7.4%	0.0%	8.7%	8.7%	8.7%	6.9%	6.9%	0.9%	6.9%	0.9%
NETWORK FACTORS														
PERLND 16	(TF)	-	-	-	-	0.650	-	-	-	-	-	-	-	-
PERLND 26	(TG)	33.359	5.272	8.092	6.944	6.944	24.488	24.488	24.488	2.757	2.757	24.102	2.757	24.102
PERLND 34	(OF)	-	1.028	10.176	12.201	12.201	-	-	-	1.215	1.215	-	1.215	-
PERLND 44	(OG)	-	3.825	0.186	5.010	5.010	3.204	3.204	3.204	10.163	10.163	12.681	10.163	12.681
PERLND 54	(SA)	-	-	1.467	0.574	0.574	-	-	-	-	-	0.380	-	0.380
IMPLND 14	(EIA)	14.497	0.399	1.467	-	-	2.627	2.627	2.627	1.049	1.049	0.354	1.049	0.354
SUM		47.856	10.524	19.921	25.379	25.379	30.319	30.319	30.319	15.184	15.184	37.467	15.184	37.467

Table 1. Miller Creek Contiguous Groundwater Subbasin Characteristics (STIA basins)

Land Use Type	Groundwater Subbasin Areas (Acres)												
	SDW1-A-O	SDW1-B-I	SDW1-B-O	SDW2a	IWS-MILLER	IWS-NCPS	IWS-NSMPS	PERVIOUS	EFFECTIVE	PERVIOUS	EFFECTIVE	PERVIOUS	EFFECTIVE
	PERVIOUS	PERVIOUS	PERVIOUS	PERVIOUS	PERVIOUS	PERVIOUS	PERVIOUS	PERVIOUS	PERVIOUS	PERVIOUS	PERVIOUS	PERVIOUS	PERVIOUS
PERLND areas:													
(16) Till-Forest	-	42.91	4.21	9.42	3.98	6.13	-	3.71	-	6.13	-	3.71	-
(26) Till-Grass	-	-	7.20	-	8.55	-	-	-	-	-	-	-	-
(34) Outwash-Forest	12.21	20.31	4.43	-	-	-	-	2.88	-	-	-	2.88	-
(44) Outwash-Grass	2.63	3.31	15.84	9.42	12.53	6.13	-	6.58	-	-	-	6.58	-
(54) Wetland	14.84	66.54	-	-	-	-	-	-	-	-	-	-	-
IMPLND areas:													
EIA	0.52	1.38	17.00	10.10	33.95	34.58	28.46	6.63	82.3%	0.7%	0.04	6.63	0.04
Basin total:	15.36	67.92	17.00	10.10	33.95	34.58	28.46	6.63	82.3%	0.7%	0.04	6.63	0.04
Percent Impervious	3.4%	2.0%	6.8%	6.7%	63.1%	82.3%	82.3%	6.7%	82.3%	0.7%	0.7%	6.7%	0.7%
NETWORK FACTORS													
PERLND 16 (TF)	-	42.915	4.214	9.421	3.982	6.127	-	3.705	-	6.127	-	3.705	-
PERLND 26 (TG)	-	-	-	-	8.549	-	-	-	-	-	-	-	-
PERLND 34 (OF)	-	20.312	7.198	-	-	-	-	-	-	-	-	-	-
PERLND 44 (OG)	12.207	3.308	4.427	-	-	-	-	2.877	-	-	-	2.877	-
PERLND 54 (SA)	2.634	1.364	1.184	0.679	21.418	28.456	0.044	0.044	-	28.456	-	0.044	-
IMPLND 14 (EIA)	0.517	67.919	17.004	10.101	33.948	34.583	28.46	6.626	-	34.583	-	6.626	-
SUM	15.358	67.919	17.004	10.101	33.948	34.583	28.46	6.626	-	34.583	-	6.626	-

Table 1. Miller Creek Contiguous Groundwater Subbasin Characteristic, 1994 (STIA basins)

Land Use	Soil Type	% of total basin equal to EIA	Areas (Acres)	
			Effective Permeable	TOTAL
PERLND areas:				
(16)	Till-Forest		31,00	
(26)	Till-Grass		342,91	
(34)	Outwash-Forest		77,06	
(44)	Outwash-Grass		499,54	
(54)	Wetland		68,73	
IMPLND areas:				
subtotal:			1019,25	
EIA				240,93
Basin total:			1260,18	
Percent Impermeous				19,1%
			TOTAL	
NETWORK FACTORS				
PERLND 16	(TF)		31,001	
PERLND 26	(TG)		342,911	
PERLND 34	(OF)		77,062	
PERLND 44	(OG)		499,543	
PERLND 54	(SA)		68,731	
IMPLND 14	(EIA)		240,934	
SUM			1260,181	

T. Miller Creek Contiguous Groundwater Subbasin Characterization 2006 (STIA basins)

Land Use	Soil Type	% of total basin equal to EIA	CARGO		M10		M16		M5		M6		M8	
			Effective	Impervious	Effective	Impervious	Effective	Impervious	Effective	Impervious	Effective	Impervious	Effective	Impervious
PERLND areas:														
(16) Till-Forest			-	-	4.15	10.93	-	-	-	-	1.42	-	-	-
(26) Till-Grass		0.01	-	-	31.94	29.93	-	-	10.29	-	20.38	-	-	-
(34) Outwash-Forest		-	-	-	20.03	20.03	-	-	-	-	13.44	-	-	-
(44) Outwash-Grass		0.01	-	-	95.22	31.83	-	-	50.05	-	11.79	-	22.21	-
(45) Fill		-	-	-	-	-	-	-	-	-	-	-	-	-
(54) Wetland		-	-	-	-	-	-	-	10.74	-	0.82	-	-	-
subtotal:		0.02	-	-	131.32	92.73	-	-	71.08	-	47.84	-	22.21	-
IMPLND areas:														
EIA		40.29	8.12	71.98	15.58	16.31	6.23	6.60	28.80	22.9%	28.80	22.9%	28.80	22.9%
Basin total:		40.30	8.12	203.30	108.31	108.31	108.31	108.31	87.39	18.7%	54.07	11.5%	28.80	22.9%
Percent Impervious		100.0%	100.0%	35.4%	14.4%	18.7%	11.5%	11.5%	18.7%	11.5%	11.5%	11.5%	22.9%	22.9%
NETWORK FACTORS														
PERLND 16 (TF)		-	-	4.155	10.932	-	-	-	-	-	1.416	-	-	-
PERLND 26 (TG)		0.008	-	31.940	29.931	-	-	-	10.293	-	20.376	-	-	-
PERLND 34 (OF)		-	-	-	20.035	-	-	-	-	-	13.444	-	-	-
PERLND 44 (OG)		0.009	-	95.222	31.833	-	-	-	50.047	-	11.791	-	22.206	-
PERLND 45 (FL)		-	-	-	-	-	-	-	-	-	-	-	-	-
PERLND 54 (SA)		-	-	-	-	-	-	-	10.743	-	0.816	-	-	-
IMPLND 14 (EIA)		40.288	8.117	71.984	15.582	16.310	16.310	16.310	6.229	-	6.229	-	6.599	-
SUM		40.305	8.117	203.300	108.313	108.313	108.313	108.313	87.392	18.7%	54.073	11.5%	28.804	22.9%

Table 1. Miller Creek Contiguous Groundwater Subbasin Characteristic :006 (STIA basins)

Land Use	Soil Type	% of total basin equal to EIA	M9		MC1n		MC2		MC3		MC4		MC5		MC6		
			Pervious	Impervious	Effective Pervious	Effective Impervious	Pervious	Impervious	Effective Pervious	Effective Impervious	Pervious	Impervious	Effective Pervious	Effective Impervious	Pervious	Impervious	
PERLND areas:																	
(16) Till-Forest		4.98		1.98	0.08	2.54											
(26) Till-Grass		14.38	0.14		0.53									13.43			
(34) Outwash-Forest		0.05			3.60			3.70									
(44) Outwash-Grass		56.71	8.44		9.20			4.91						33.84		14.10	
(45) Fill			0.14		2.22			1.07								0.09	
(54) Wetland		0.01	0.27		15.14			1.84						7.44		0.90	
IMPLND areas:		76.14	9.99		30.77			11.52						54.71		15.09	
EIA																	
Basin total:		98.61	22.47	1.98	33.31	2.54	1.42	12.94	7.6%	11.0%	36.31	9.1%	54.74	0.02	15.35	0.26	
Percent Impervious			22.8%	16.5%		7.6%	11.0%				9.1%	0.0%				1.7%	
NETWORK FACTORS																	
PERLND 16 (TF)		4.981			0.078												
PERLND 26 (TG)		14.384	0.138		0.531									13.432			
PERLND 34 (OF)		0.048			3.598			3.701									
PERLND 44 (OG)		56.712	9.437		9.205			4.910						33.842		14.098	
PERLND 45 (FL)			0.140		2.221			1.070								0.092	
PERLND 54 (SA)		0.011	0.272		15.139			1.843						7.438		0.899	
IMPLND 14 (EIA)		22.472	1.979		2.538			1.419						0.025		0.260	
SUM		98.608	11.966		33.311			12.943						54.738		15.350	

Table 1. Miller Creek Contiguous Groundwater Subbasin Characteristics .006 (STIA basins)

Land Use	Soil Type	% of total basin equal to EIA	Groundwater Subbasin Areas (Acres)													
			MC7		NEPL		SDN1		SDN1-LWR		SDN1-OFF		SDN2-Xh		SDN3	
			Effective Pervious	Effective Impervious	Effective Pervious	Effective Impervious	Effective Pervious	Effective Impervious	Effective Pervious	Effective Impervious	Effective Pervious	Effective Impervious	Effective Pervious	Effective Impervious	Effective Pervious	Effective Impervious
PERLND areas:																
(16) Till-Forest			-	10.00	-	0.09	-	-	-	12.27	-	0.63	-	23.56	-	-
(26) Till-Grass			-	-	-	0.87	-	4.79	-	2.22	-	2.40	-	-	-	-
(34) Outwash-Forest			-	-	-	-	-	-	-	-	-	0.86	-	-	-	-
(44) Outwash-Grass			-	-	-	-	-	-	-	-	-	-	-	-	-	-
(45) Fill			-	-	-	0.01	-	0.07	-	1.08	-	-	-	-	-	-
(54) Wetland			-	-	-	0.97	-	4.66	-	15.57	-	3.90	-	23.56	-	-
subtotal:			46.26	10.00	32.29	6.51	6.51	0.56	4.74	20.32	4.26	4.26	47.86	24.30	50.8%	
IMPLND areas:																
EIA			0.03	42.29	76.4%	7.48	87.1%	10.4%	23.3%	8.5%	47.86	50.8%				
Basin total:			46.29	42.29	76.4%	7.48	87.1%	10.4%	23.3%	8.5%	47.86	50.8%				
Percent Impervious			MC7	NEPL	SDN1	SDN1-LWR	SDN1-OFF	SDN2-Xh	SDN3							
			0.1%	76.4%	87.1%	10.4%	23.3%	8.5%	50.8%							
NETWORK FACTORS																
PERLND 16 (TF)			-	-	-	0.087	-	-	-	12.275	-	0.632	-	23.556	-	-
PERLND 26 (TG)			11.260	10.000	-	0.874	-	4.787	-	2.222	-	2.405	-	-	-	-
PERLND 34 (OF)			-	-	-	-	-	-	-	-	-	0.860	-	-	-	-
PERLND 44 (OG)			31.795	-	-	-	-	-	-	-	-	-	-	-	-	-
PERLND 45 (FL)			-	-	-	0.006	-	0.071	-	1.078	-	-	-	-	-	-
PERLND 54 (SA)			3.202	32.291	-	6.511	-	0.565	-	4.742	-	0.363	-	24.300	-	-
IMPLND 14 (EIA)			0.032	42.291	-	7.478	-	5.423	-	20.316	-	4.260	-	47.856	-	-
SUM			46.288	42.291												

Table 3 Miller Creek Contiguous Groundwater Subbasin Characteristics: 2006 (STIA basins)

Land Use	Soil Type	% of total basin equal to EIA	SDN3-A-I		SDN3-A-O		SDN3-X		SDN4		SDN4-X		SDW1-A-I		SDW1-A-O	
			PerVIOUS	Effective	PerVIOUS	Effective	PerVIOUS	Effective	PerVIOUS	Effective	PerVIOUS	Effective	PerVIOUS	Effective	PerVIOUS	Effective
PERLND areas:																
(16) Till-Forest			-	1.61	-	15.75	-	1.92	-	4.28	-	1.92	-	4.28	-	1.64
(26) Till-Grass			0.08	-	-	-	-	-	-	-	-	-	-	-	-	-
(34) Outwash-Forest			-	-	0.03	1.31	-	0.75	-	-	-	0.75	-	-	0.69	-
(44) Outwash-Grass			-	-	17.54	0.99	-	8.31	-	19.41	-	8.31	-	19.41	13.03	-
(45) Fill			4.58	23.77	-	-	-	-	-	-	-	-	-	-	-	-
(54) Wetland			-	25.38	-	18.06	-	10.97	-	23.69	-	10.97	-	23.69	13.72	-
IMPLND areas:																
subtotal:			4.66	25.38	17.57	18.06	-	10.97	-	23.69	-	10.97	-	23.69	13.72	-
EIA			5.87	2.35	0.00	12.26	-	4.21	-	13.78	-	4.21	-	13.78	1.64	-
Basin total:			10.52	19.92	19.92	30.32	15.18	37.47	15.18	37.47	15.18	37.47	15.18	37.47	15.36	10.7%
Percent Impervious			55.7%	11.8%	0.0%	40.4%		27.7%		36.8%		27.7%		36.8%		10.7%
NETWORK FACTORS																
PERLND 16 (TF)			-	1.613	-	15.755	-	1.916	-	4.278	-	1.916	-	4.278	-	-
PERLND 26 (TG)			0.077	-	-	-	-	-	-	-	-	-	-	-	-	-
PERLND 34 (OF)			-	-	0.032	1.309	-	0.750	-	-	-	0.750	-	-	0.688	-
PERLND 44 (OG)			-	23.766	17.537	0.992	-	8.305	-	19.412	-	8.305	-	19.412	13.031	-
PERLND 45 (FL)			4.581	-	-	-	-	-	-	-	-	-	-	-	-	-
PERLND 54 (SA)			-	0.000	-	12.263	-	4.213	-	13.777	-	4.213	-	13.777	1.639	-
IMPLND 14 (EIA)			5.866	25.379	19.921	30.319	-	15.184	-	37.467	-	15.184	-	37.467	15.358	-
SUM			10.524	19.921	19.921	30.319	15.184	37.467	15.184	37.467	15.184	37.467	15.184	37.467	15.358	10.7%

AR 020229

Table 1. Miller Creek Contiguous Groundwater Subbasin Characterization 2006 (STIA basins)

Land Use	Soil Type	% of total basin equal to EIA	Groundwater Subbasin Areas (Acres)					
			SDW1-B-1	SDW1-B-O	IWS-NCPS	IWS-NSMPS	TOTAL	Effective Permeability
			Effective Permeability	Effective Permeability	Effective Permeability	Effective Permeability	Effective Permeability	Effective Permeability
			Permeability	Permeability	Permeability	Permeability	Permeability	Permeability
PERLND areas:								
(16) Till-Forest			20.37	0.89	4.78	-	2.69	21.56
(26) Till-Grass			-	2.39	-	-	1.97	231.20
(34) Outwash-Forest			35.97	10.30	-	-	0.01	41.10
(44) Outwash-Grass			-	0.00	-	-	-	405.05
(45) Fill			56.33	13.58	4.78	4.67	-	53.50
(54) Wetland			-	-	-	-	-	894.93
subtotal:			23.52	3.42	29.80	1.95	-	364.73
IMPLND areas:								
EIA			79.86	17.00	34.58	5.63	-	1259.68
Basin total:			29.5%	20.1%	86.2%	29.5%	-	29.0%
Percent Impervious			SDW1-B-1	SDW1-B-O	IWS-NCPS	IWS-NSMPS	TOTAL	
NETWORK FACTORS								
PERLND 16 (TF)			-	0.888	4.761	-	2.686	21.562
PERLND 26 (TG)			20.365	-	-	-	-	231.204
PERLND 34 (OF)			-	-	-	-	-	41.101
PERLND 44 (OG)			-	2.392	-	-	-	405.053
PERLND 45 (FL)			35.966	10.298	-	-	-	53.500
PERLND 54 (SA)			-	0.005	-	-	-	364.729
IMPLND 14 (EIA)			23.525	3.421	29.802	1.954	-	1259.663
SUM			79.856	17.004	34.583	6.826	-	

Table 1. Miller Creek Non-Contiguous Groundwater Subbasin Characterization - 1994 (STIA basins)

Land Use	Soil Type	% of total basin equal to EIA	SDW-1B-1		SDW-2a		TOTAL	
			Effective PerVIOUS/Impervious	Effective PerVIOUS/Impervious	Effective PerVIOUS/Impervious	Effective PerVIOUS/Impervious	Effective PerVIOUS/Impervious	Effective PerVIOUS/Impervious
PERLND areas:								
(16) Till-Forest		-	-	-	-	-	-	-
(26) Till-Grass		0.04	10.14	4.06	14.24	14.24	14.24	14.24
(34) Outwash-Forest		-	-	-	-	-	-	-
(44) Outwash-Grass		-	-	-	-	-	-	-
(54) Wetland		-	-	-	-	-	-	-
subtotal:		0.04	10.14	4.06	14.24	14.24	14.24	14.24
IMPLND areas:								
EIA		6.52	1.79	0.61	8.92	8.92	8.92	8.92
Basin total:		6.56	11.94	4.67	23.16	23.16	23.16	23.16
Percent impervious		99.4%	15.0%	13.1%	38.5%	38.5%	38.5%	38.5%
NETWORK FACTORS			SIDE4		SDW-1B-1		SDW-2a	
PERLND 16 (TF)		-	-	-	-	-	-	-
PERLND 26 (TG)		0.037	10.144	4.059	14.240	14.240	14.240	14.240
PERLND 34 (OF)		-	-	-	-	-	-	-
PERLND 44 (OG)		-	-	-	-	-	-	-
PERLND 54 (SA)		6.519	1.793	0.610	8.922	8.922	8.922	8.922
IMPLND 14 (EIA)		6.556	11.936	4.689	23.162	23.162	23.162	23.162
SUM								

Table 1. Miller Creek Non-Contiguous Groundwater Subbasin Characterization - 2006 (STIA basins)

Land Use	Soil Type	% of total basin equal to EIA	Groundwater Subbasin Areas (Acres)								
			SDE4 Pervious, Impervious	SDS3A Effective, Pervious, Impervious	SDW-2a Effective, Pervious, Impervious	TOTAL	SDE4 Pervious, Impervious	SDS3A Effective, Pervious, Impervious	SDW-2a Effective, Pervious, Impervious	TOTAL	
PERLND areas:											
(16)	Till-Forest		0.04	1.72	-	11.06	-	12.82			
(26)	Till-Grass		-	-	-	-	-	-			
(34)	Outwash-Forest		-	-	-	-	-	-			
(44)	Outwash-Grass		-	-	-	1.09	-	-			
(45)	Fill		-	-	-	-	-	-			
(54)	Wetland		-	-	-	-	-	-			
IMPLND areas:											
subtotal:			0.04	1.72	-	12.15	-	13.91			
EIA			6.56	6.52	0.70	14.77	2.62	9.84			
Basin total:			6.56	2.43	0.70	14.77	2.62	23.75			
Percent Impervious			99.4%	29.0%	17.8%			141.4%			
NETWORK FACTORS											
PERLND 16	(1F)		0.039	1.722	-	11.057	-	12.817			
PERLND 26	(1G)		-	-	-	-	-	-			
PERLND 34	(0F)		-	-	-	-	-	-			
PERLND 44	(0G)		-	-	-	1.091	-	-			
PERLND 45	(1L)		-	-	-	-	-	-			
PERLND 54	(1A)		-	-	-	-	-	-			
IMPLND 14	(1A)		6.518	0.705	2.622	14.770	9.844	23.753			
SUM			6.556	2.427	2.622	14.770	9.844	23.753			

Table 1. Walker Creek Surface Water Subbasin Characteristics - 1994 (EIA basins)

Land Use	Soil Type	% of total basin equal to EIA	Surface Water Subbasin Areas (Acres)													
			M20		MC8		MC9		SIDW-2		Total		Percent of Total Effective			
			Pervious	Impervious	Pervious	Impervious	Pervious	Impervious	Pervious	Impervious	Pervious	Impervious	Pervious	Impervious		
COMM	Qvr	85%	7.04	39.91	-	-	-	-	-	-	-	-	7.04	39.91	3.01%	17.06%
	Qvr	85%	-	-	-	-	-	-	-	-	-	-	-	-	0.00%	0.00%
	Qvt	85%	-	-	-	-	-	-	-	-	-	-	-	-	0.00%	0.00%
F	M	0%	-	-	-	-	-	-	-	-	-	-	-	-	0.00%	0.00%
	Qu	0%	-	-	-	-	-	-	-	-	-	-	-	-	0.00%	0.00%
	Qvr	0%	-	-	-	-	-	-	-	-	-	-	-	-	0.00%	0.00%
	Qvt	0%	-	-	-	-	-	-	-	-	-	-	-	-	0.00%	0.00%
	Qw	0%	-	-	-	-	-	-	-	-	-	-	-	-	0.00%	0.00%
HD	Qvr	15%	3.66	0.65	3.58	0.63	-	-	1.54	0.27	8.79	1.55	8.79	1.55	3.75%	0.66%
	Qvt	15%	0.16	0.03	-	-	-	-	-	-	0.16	0.03	0.16	0.03	0.07%	0.01%
	Qvt	15%	-	-	3.99	0.70	-	6.26	1.11	-	10.25	1.81	10.25	1.81	4.38%	0.77%
	Qw	15%	-	-	-	-	-	-	-	-	-	-	-	-	0.00%	0.00%
LD	M	4%	-	-	-	-	-	-	-	-	-	-	-	-	0.00%	0.00%
	Qu	4%	-	-	-	-	-	-	-	-	-	-	-	-	0.00%	0.00%
	Qvr	4%	20.81	0.87	-	-	-	-	-	-	20.81	0.87	20.81	0.87	8.89%	0.37%
	Qvt	4%	0.00	0.00	-	-	-	-	-	-	0.00	0.00	0.00	0.00	0.00%	0.00%
	Qvt	4%	-	-	-	-	-	-	-	-	-	-	-	-	0.00%	0.00%
	Qw	4%	-	-	-	-	-	-	-	-	-	-	-	-	0.00%	0.00%
MF	Qvr	47%	-	-	-	-	-	-	-	-	-	-	-	-	0.00%	0.00%
	Qvt	47%	-	-	-	-	-	-	-	-	-	-	-	-	0.00%	0.00%
OG	M	0%	-	-	-	-	-	6.37	0.41	-	6.79	-	6.79	-	2.90%	0.00%
	Qvr	0%	11.16	-	13.79	-	-	0.41	0.78	-	26.14	-	26.14	-	11.17%	0.00%
	Qvt	0%	9.37	-	-	-	-	-	-	-	9.37	-	9.37	-	4.00%	0.00%
	Qvt	0%	0.31	-	0.11	-	-	-	11.55	-	11.97	-	11.97	-	5.11%	0.00%
	Qw	0%	-	-	-	-	-	-	-	-	-	-	-	-	0.00%	0.00%
STIA	M	0%	-	-	-	-	-	1.31	19.07	-	20.38	-	20.38	-	8.71%	0.00%
	Qvr	0%	-	-	-	-	-	-	0.54	-	0.54	-	0.54	-	0.00%	0.00%
	Qvt	0%	-	-	-	-	-	-	-	-	-	-	-	-	0.00%	0.00%
	Qw	0%	-	-	-	-	-	-	-	-	-	-	-	-	0.00%	0.00%
	TIA	100%	-	-	-	-	0.23	-	-	1.94	-	2.17	-	2.17	0.00%	0.93%

Table Walker Creek Surface Water Subbasin Characteristics - 1994 (basins)

Land Use	Soil Type	% of total basin equal to EIA	Surface Water Subbasin Areas (Acres)														
			M20		MC8		MC9		SDW-2		Total		Percent of Total				
			Pervious	Effective Impervious	Pervious	Effective Impervious	Pervious	Effective Impervious	Pervious	Effective Impervious	Pervious	Effective Impervious	Pervious	Effective Impervious			
TRANS	M	0%	1.74	-	-	-	1.76	-	-	-	-	-	-	3.50	-	1.50%	0.00%
	Qvr	0%	10.76	-	1.19	-	0.33	-	-	-	-	-	-	12.28	-	5.25%	0.00%
	Qvl	0%	0.95	-	-	-	-	-	-	-	-	-	-	0.95	-	0.41%	0.00%
	Qvt	0%	-	-	-	-	-	-	-	-	-	-	-	-	-	0.00%	0.00%
	Qw	0%	-	-	-	-	-	-	-	-	-	-	-	-	-	0.00%	0.00%
	TIA	100%	-	11.38	-	0.01	-	-	-	-	-	-	-	-	11.39	0.00%	4.87%
	Welland	0%	33.43	-	2.72	-	-	-	1.13	-	-	-	-	37.28	-	15.93%	-
	Lake	-	-	-	-	-	-	-	-	-	-	-	-	-	-	0.00%	-
	Mork-df	-	-	-	-	-	-	-	-	-	-	-	-	-	-	0.00%	-
	Other	-	-	-	-	-	-	-	-	-	-	-	-	-	-	0.00%	-
Basin total:			99.40	52.83	25.38	1.34	10.19	0.24	41.29	3.31	176.26	57.73	75.33%	24.67%			
PERLND areas:																	
(16)	Till-Forest	-	-	-	-	-	-	-	-	-	-	-	-	-	-	0.00%	-
(26)	Till-Grass	-	12.53	-	4.10	-	8.44	-	37.84	-	63.92	-	27.32%	0.00%			
(34)	Outwash-Forest	-	-	-	-	-	-	-	-	-	-	-	-	-	-	0.00%	-
(44)	Outwash-Grass	-	53.43	-	18.57	-	0.74	-	2.32	-	75.06	-	32.08%	0.00%			
(54)	Welland	-	33.43	-	2.72	-	-	-	1.13	-	37.28	-	15.93%	0.00%			
	subtotal:		99.40	52.83	25.38	1.34	10.19	0.24	41.29	3.31	176.26	57.73	75.33%	24.67%			
IMPLND areas:																	
EIA			52.83	-	-	-	-	-	-	-	-	-	-	-	-	-	-
Basin total:			152.23	34.7%	26.73	5.0%	10.43	2.3%	44.60	7.4%	233.98	100.00%	100.00%				
Percent Impervious																	
NETWORK FACTORS																	
PERLND 16	(TF)	-	-	-	-	-	-	-	-	-	-	-	0.00%				
PERLND 26	(TG)	12.534	4.088	9.445	37.840	63.917	27.32%	0.00%									
PERLND 34	(OF)	-	-	-	-	-	-	-	-	-	-	-	0.00%				
PERLND 44	(OG)	53.431	18.568	0.743	2.321	75.063	32.08%	0.00%									
PERLND 54	(SA)	33.431	2.717	-	1.129	37.277	15.93%	0.00%									
IMPLND 14	(EIA)	52.833	1.343	0.239	3.313	57.729	24.67%	0.00%									
SUM		152.229	26.727	10.427	44.603	233.986	100.00%	100.00%									

Table 1. Walker Creek Surface Water Subbasin Characteristics - 1994 (basins)

Land Use	Soil Type	equal to EIA	% of total basin	Area (Acres)		
				(Model SDW2)	Special MC-8b	Effective
COMM	Qvr	85%				
	Qvr	85%				
	Qvt	85%				
F	M	0%				
	Qu	0%				
	Qvr	0%				
	Qvrl	0%				
	Qvt	0%				
	Qw	0%				
HD	Qvr	15%		4.28	0.76	
	Qvrl	15%				
	Qvt	15%		6.59	1.16	
	Qw	15%				
LD	M	4%				
	Qu	4%				
	Qvr	4%				
	Qvrl	4%				
	Qvt	4%				
	Qw	4%				
MF	Qvr	47%				
	Qvrl	47%				
OG	M	0%		1.85		
	Qvr	0%		16.42		
	Qvrl	0%				
	Qvt	0%		11.15		
	Qw	0%				
STIA	M	0%		0.69		
	Qvr	0%				
	Qvt	0%		0.63		
	Qw	0%				
	TIA	100%				0.28

Table 1. Walker Creek Surface Water Subbasin Characteristics - 1994 (basins)

Land Use	Soil Type	% of total basin equal to EIA	Area (Acres)	
			(Model SDW2) Special MC-8b	Effective PerVIOUS Impervious
TRANS M		0%	-	-
Qvr		0%	-	-
Qvrl		0%	-	-
Qvt		0%	-	-
Qw		0%	-	-
TIA		100%	-	-
Welland		0%	1.05	-
Lake			-	-
Merck-df			-	-
Other			-	-
Basin total:			42.66	2.20
PERLND areas:				
(16) Till-Forest			-	-
(26) Till-Grass			20.91	-
(34) Outwash-Forest			-	-
(44) Outwash-Grass			20.70	-
(54) Welland			1.05	-
subtotal:			42.66	-
IMPLND areas:				2.20
EIA				2.20
Basin total:			44.86	4.9%
Percent Impervious				
			Special MC-8b	
NETWORK FACTORS				
PERLND 16	(TF)		-	-
PERLND 26	(TG)		20.906	-
PERLND 34	(OF)		-	-
PERLND 44	(OG)		20.704	-
PERLND 54	(SA)		1.050	-
IMPLND 14	(EIA)		2.197	-
SUM			44.857	

Walker Creek Surface Water Subbasin Characteristics - 2008 (basins)

Land Use	Soil Type	% of total basin equal to EIA	Surface Water Subbasin Areas (Acres)												
			M20		MC8		MC9		SDW-2		Total		Percent of Total		
			Pervious	Effective Impervious	Pervious	Effective Impervious	Pervious	Effective Impervious	Pervious	Effective Impervious	Pervious	Effective Impervious	Pervious	Effective Impervious	
COMM	Qvr	85%	7.04	39.91	-	-	-	-	-	-	-	7.04	39.91	3.03%	17.16%
	Qvt	85%	-	-	-	-	-	-	-	-	-	-	-	0.00%	0.00%
F	Fill	0%	-	-	-	-	-	-	-	-	-	-	-	0.00%	0.00%
	M	0%	-	-	-	-	-	-	-	-	-	-	-	0.00%	0.00%
	Qu	0%	-	-	-	-	-	-	-	-	-	-	-	0.00%	0.00%
	Qvr	0%	-	-	-	-	-	-	-	-	-	-	-	0.00%	0.00%
	Qvt	0%	-	-	-	-	-	-	-	-	-	-	-	0.00%	0.00%
	Qw	0%	-	-	-	-	-	-	-	-	-	-	-	0.00%	0.00%
HD	Qvr	15%	3.66	0.65	-	-	-	-	-	-	-	3.66	0.65	1.57%	0.28%
	Qvt	15%	0.16	0.03	-	-	-	-	-	-	-	0.16	0.03	0.07%	0.01%
	Qvt	15%	-	-	-	-	-	-	-	-	-	-	-	0.00%	0.00%
LD	M	4%	-	-	-	-	-	-	-	-	-	-	-	0.00%	0.00%
	Qu	4%	-	-	-	-	-	-	-	-	-	-	-	0.00%	0.00%
	Qvr	4%	20.80	0.87	-	-	-	-	-	-	-	20.80	0.87	8.94%	0.37%
	Qvt	4%	0.00	0.00	-	-	-	-	-	-	-	0.00	0.00	0.00%	0.00%
	Qvt	4%	-	-	-	-	-	-	-	-	-	-	-	0.00%	0.00%
MF	Qvr	47%	-	-	-	-	-	-	-	-	-	-	-	0.00%	0.00%
	Qvt	47%	-	-	-	-	-	-	-	-	-	-	-	0.00%	0.00%
OG	M	0%	-	-	-	-	-	-	-	-	-	-	-	0.00%	0.00%
	Qvr	0%	11.05	-	16.42	5.10	-	-	-	-	-	5.10	-	2.19%	0.00%
	Qvt	0%	9.33	-	0.30	0.30	-	-	-	-	-	27.78	-	11.94%	0.00%
	Qvt	0%	0.31	-	2.89	-	-	-	-	-	-	9.33	-	4.01%	0.00%
	Qw	0%	-	-	-	-	-	-	-	-	-	3.20	-	1.38%	0.00%
STIA	Fill	0%	-	-	-	-	-	-	-	-	-	6.70	-	2.88%	0.00%
	M	0%	-	-	-	2.42	-	-	-	-	-	22.81	-	9.81%	0.00%
	Qvr	0%	-	-	1.11	0.12	-	-	-	-	-	2.74	-	1.18%	0.00%
	Qvt	0%	-	-	1.04	-	-	-	-	-	-	7.53	-	3.24%	0.00%
	Qw	0%	-	-	-	-	-	-	-	-	-	-	-	0.00%	0.00%
	TIA	100%	-	-	-	-	-	-	-	-	-	-	-	0.00%	4.28%

Table 1. Walker Creek Surface Water Subbasin Characteristics - 2006 (. basins)

Land Use	Soil Type	% of total basin equal to EIA	Surface Water Subbasin Areas (Acres)														
			M20		MC8		MC9		SDW-2		Total		Percent of Total				
			Pervious	Effective Impervious	Pervious	Effective Impervious	Pervious	Effective Impervious	Pervious	Effective Impervious	Pervious	Effective Impervious	Pervious	Effective Impervious			
TRANS	M	0%	1.74	-	-	1.76	-	-	-	-	-	-	-	3.50	-	1.51%	0.00%
	Qvr	0%	10.87	-	1.19	0.33	-	-	-	-	-	-	-	12.39	-	5.33%	0.00%
	Qvrl	0%	1.00	-	-	-	-	-	-	-	-	-	-	1.00	-	0.43%	0.00%
	Qvt	0%	-	-	-	-	-	-	-	-	-	-	-	-	-	0.00%	0.00%
	Qw	0%	-	-	-	-	-	-	-	-	-	-	-	-	-	0.00%	0.00%
	TIA	100%	-	11.38	-	0.01	-	-	-	-	-	-	-	-	11.40	0.00%	4.90%
Welland		0%	33.43	-	2.70	-	-	-	-	-	-	-	-	36.13	-	15.53%	
Lake			-	-	1.36	-	-	-	-	-	-	-	-	1.36	-	0.58%	
Mcrrk-df			-	-	-	-	-	-	-	-	-	-	-	-	-	0.00%	
Other			0.00	-	-	-	-	-	-	-	-	-	-	0.00	-	0.00%	
Basin total:			99.39	52.83	25.36	10.03	0.01	0.40	35.09	62.75	169.88	26.98%					
PERLND areas:																	
(16)	Till-Forest		-	-	-	-	-	-	-	-	-	-	-	-	-	0.00%	
(26)	Till-Grass		12.54	-	3.83	9.28	-	-	26.88	-	52.63	22.63%					
(34)	Outwash-Forest		-	-	-	-	-	-	-	-	-	-	-	-	-	0.00%	
(44)	Outwash-Grass		53.42	-	18.73	0.76	-	-	1.51	-	74.42	31.99%					
(45)	Fill		-	-	-	-	-	-	6.70	-	6.70	2.88%					
(64)	Welland		33.43	-	2.70	-	-	-	-	-	36.13	15.53%					
subtotal:			99.39	52.83	25.36	10.03	0.01	0.40	35.09	62.75	169.88	26.98%					
IMPLND areas:																	
EIA			52.83	0.01	0.40	9.51	21.3%										
Basin total:			152.23	34.7%	26.37	10.43	3.8%	44.60	232.63	100.00%							
Percent impervious																	
NETWORK FACTORS																	
PERLND 16	(TF)		-	-	3.934	9.275	-	-	26.884	-	52.633	22.63%					
PERLND 26	(TG)		12.540	-	-	-	-	-	-	-	-	0.00%					
PERLND 34	(OF)		-	-	18.729	0.756	-	-	1.508	-	74.417	31.99%					
PERLND 44	(OG)		53.424	-	-	-	-	-	6.697	-	6.697	2.88%					
PERLND 45	(FL)		-	-	2.699	-	-	-	-	-	36.130	15.53%					
PERLND 54	(SA)		33.431	-	0.008	0.395	-	-	9.514	-	62.752	26.98%					
IMPLND 14	(EIA)		52.835	-	25.370	10.427	-	-	44.603	-	232.629	100.00%					
SUM			152.229		25.370	10.427			44.603		232.629	100.00%					

Table 1. Walker Creek Contiguous Groundwater Subbasin Characteristics - 1994 (STIA basins)

Land Use	Soil Type	% of total basin equal to EIA	SDS7a		SDS7b		M16		M20		MC8		MC9		SDW-2a	
			Pervious	Effective Impervious	Pervious	Effective Impervious	Pervious	Effective Impervious	Pervious	Effective Impervious	Pervious	Effective Impervious	Pervious	Effective Impervious	Pervious	Effective Impervious
PERLND areas:																
(16)	Till-Forest		0.22	23.06	1.72	0.00	12.53	4.10	8.81	10.64	0.24	1.34	9.80	0.24	1.14	
(26)	Till-Grass		-	-	-	0.00	53.43	16.57	0.75	2.31	0.68	2.72	0.75	0.68	2.31	
(34)	Outwash-Forest		-	4.59	-	0.00	33.43	2.72	-	0.68	2.72	2.72	-	0.68	2.31	
(44)	Outwash-Grass		-	0.37	-	0.00	99.40	25.38	-	13.62	9.56	25.38	-	9.56	13.62	
(54)	Wetland		0.22	28.03	-	0.00	-	-	-	-	-	-	-	-	-	
IMPLND areas:																
EIA																
Basin total:			0.30	29.75	1.72	0.00	152.23	26.73	9.80	14.76	0.24	1.34	9.80	0.24	1.14	
Percent Impervious			25.3%	5.8%	4.2%	34.7%	5.0%	2.4%	7.7%							
NETWORK FACTORS																
PERLND 16	(IF)		0.223	23.060	0.002	12.534	4.098	8.813	10.640	0.240	1.340	9.813	0.240	1.140		
PERLND 26	(TG)		-	-	0.000	53.431	18.568	0.746	2.306	0.675	2.717	0.746	0.675	2.306		
PERLND 34	(OF)		-	4.593	0.000	33.431	2.717	-	0.675	2.306	2.717	-	0.675	2.306		
PERLND 44	(OG)		-	0.375	0.000	52.833	1.343	0.239	1.140	1.140	1.343	0.239	1.140	1.140		
PERLND 54	(SA)		0.076	1.721	0.002	152.229	26.727	9.798	14.761	0.240	1.340	9.798	0.240	1.140		
IMPLND 14	(EIA)		0.299	29.748	0.002											
SUM																

Table 1. Walker Creek Contiguous Groundwater Subbasin Characteristics : 1994 (STIA basins)

Land Use	Soil Type	% of total basin equal to EIA	Areas (Acres)
			TOTAL
			Effective, PerVIOUS
			Impervious
PERLND areas:			
(16)	Till-Forest		
(26)	Till-Grass		59,370
(34)	Outwash-Forest		79,844
(44)	Outwash-Grass		37,200
(54)	Wetland		176,211
subtotal:			67,335
IMPLND areas:			
EIA			233,564
Basin total:			233,564
Percent Impervious			24.6%
			TOTAL
NETWORK FACTORS			
PERLND 16	(TF)		
PERLND 26	(TG)		59,370
PERLND 34	(OF)		79,844
PERLND 44	(OG)		37,198
PERLND 54	(SA)		57,352
IMPLND 14	(EIA)		233,564
SUM			233,564

AR 020240

Table 1. Walker Creek Contiguous Groundwater Subbasin Characteristics : 2006 (STIA basins)

Land Use Type	Soil Type	% of total basin equal to EIA	SDS7a		M16		M20		M20		M20		M20		M20		M20		M20		M20	
			Pervious	Impervious	Effective Pervious	Effective Impervious	Pervious	Impervious	Effective Pervious	Effective Impervious	Pervious	Impervious	Effective Pervious	Effective Impervious	Pervious	Impervious	Effective Pervious	Effective Impervious	Pervious	Impervious	Effective Pervious	Effective Impervious
PERLND areas:																						
(16) Till-Forest																						
(26) Till-Grass																						
(34) Outwash-Forest																						
(44) Outwash-Grass																						
(45) Fill																						
(54) Wetland																						
subtotal:																						
IMPLND areas:																						
EIA																						
Basin total:																						
Percent Impervious																						
NETWORK FACTORS																						
PERLND 16 (TF)																						
PERLND 26 (TG)																						
PERLND 34 (OF)																						
PERLND 44 (OG)																						
PERLND 45 (FL)																						
PERLND 54 (SA)																						
IMPLND 14 (EIA)																						
SUM																						

Walker Creek Contiguous Groundwater Subbasin Characterization, 2006 (STIA basins)

Land Use	Soil Type	% of total basin equal to EIA	Area (Acres)	
			Effective Permeable	TOTAL
PERLND areas:				
(16) Till-Forest				
(26) Till-Grass				
(34) Outwash-Forest				
(44) Outwash-Grass				
(45) Fill				
(54) Wetland				
subtotal:			36,130	60,277
IMPLND areas:				
EIA				60,277
Basin total:			217,533	
Percent Impermeous				27.7%
				TOTAL
NETWORK FACTORS				
PERLND 16 (TF)			41,112	
PERLND 28 (TG)				
PERLND 34 (OF)			74,417	
PERLND 44 (OG)			15,606	
PERLND 45 (FL)			36,130	
PERLND 54 (SA)			60,285	
IMPLND 14 (EIA)				60,285
SUM			217,531	

Table 10 Walker Creek Non-Contiguous Groundwater Subbasin Characteritics - 1994 (STIA basins)

Land Use Type	% of total basin equal to EIA	D8		SDE4		SDS1		SDS3		SDS3A		SDS5	
		Effective Pervious	Effective Impervious	Effective Pervious	Effective Impervious	Effective Pervious	Effective Impervious	Effective Pervious	Effective Impervious	Effective Pervious	Effective Impervious	Effective Pervious	Effective Impervious
PERLND areas:													
(16) Till-Forest													
(26) Till-Grass	0.01	1.82	48.98	0.07	162.03	0.07	60.57	21.53					
(34) Outwash-Forest	-	1.46	-	-	-	-	-	-	-	-	-	-	-
(44) Outwash-Grass	-	0.05	-	-	-	-	-	-	-	-	-	-	-
(54) Wetland	0.01	3.33	48.98	0.07	162.03	0.07	60.57	21.53					
subtotal:	0.06			2.80		7.73							
EIA													
Basin total:	0.07	6.13	148.10	7.80	337.23	7.80	67.35	21.57	6.78	21.57	6.78	0.04	0.04
Percent Impervious	85.0%	45.7%	66.9%	99.1%	52.0%	99.1%	10.1%	10.1%	10.1%	10.1%	10.1%	0.2%	0.2%
	D3	D8	SDE4	SDS1	SDS3	SDS3A	SDS5	SDS5	SDS5	SDS5	SDS5	SDS5	SDS5
NETWORK FACTORS													
PERLND 16 (TF)	-	-	-	-	-	-	-	-	-	-	-	-	-
PERLND 26 (TG)	0.010	1.820	48.975	0.069	162.030	0.069	60.575	21.531					
PERLND 34 (OF)	-	-	-	-	-	-	-	-	-	-	-	-	-
PERLND 44 (OG)	-	1.459	-	-	-	-	-	-	-	-	-	-	-
PERLND 54 (SA)	-	0.050	-	-	-	-	-	-	-	-	-	-	-
IMPLND 14 (EIA)	0.058	2.801	99.123	7.732	175.197	7.732	6.776	0.041					
SUM	0.068	6.130	148.098	7.801	337.227	7.801	67.360	21.572	6.78	21.57	6.78	0.04	0.04

4. Walker Creek Non-Contiguous Groundwater Subbasin Character

Land Use	Soil Type	% of total basin equal to EIA	SDS6		SDS7a		IWS NSPS		IWS PRIMARY		IWS WEST		MC9		SDW2b	
			PerVIOUS	Effective Impervious	PerVIOUS	Effective Impervious	PerVIOUS	Effective Impervious	PerVIOUS	Effective Impervious	PerVIOUS	Effective Impervious	PerVIOUS	Effective Impervious	PerVIOUS	Effective Impervious
PERLND areas:																
(16) Till-Forest																
(26) Till-Grass		10.69		54.98		0.31		11.98		1.63		0.51		13.74		
(34) Outwash-Forest																
(44) Outwash-Grass																
(54) Wetland				0.02												
subtotal:		10.69		54.99		0.31		11.96		1.63		0.51		0.45		14.19
IMPLND areas:																
EIA																
Basin total:		14.79		61.21		13.75		227.94		2.04		0.51		15.07		0.88
Percent impervious																
					10.2%		97.8%		94.8%		20.4%		0.0%			
NETWORK FACTORS																
PERLND 16 (TF)																
PERLND 26 (TG)		10.686		54.978		0.307		11.961		1.625		0.514		13.735		
PERLND 34 (OF)																
PERLND 44 (OG)																
PERLND 54 (SA)				0.016												
IMPLND 14 (EIA)		4.102		6.214		13.441		215.980		0.416				0.454		0.883
SUM		14.788		61.207		13.747		227.941		2.041		0.514		15.073		

Table 1. Walker Creek Non-Contiguous Groundwater Subbasin Characteritics - 1994 (STIA basins)

Land Use	Soil Type	% of total basin equal to EIA	Groundwater Subbasin Areas (Acres)	
			IWS-NGPS	TOTAL
			Effective Pervious	Effective Impervious
PERLND areas:				
(16)	Till-Forest			
(26)	Till-Grass	0.80	389.62	
(34)	Outwash-Forest			
(44)	Outwash-Grass		1.46	
(54)	Wetland		0.52	
	subtotal:	0.80	391.60	
IMPLND areas:				
	EIA		0.33	533.09
Basin total:			924.69	
Percent Impervious			29.2%	57.7%
			TOTAL	
NETWORK FACTORS				
PERLND 16	(TF)			
PERLND 26	(TG)	0.801	389.618	
PERLND 34	(OF)			
PERLND 44	(OG)		1.459	
PERLND 54	(SA)		0.519	
IMPLND 14	(EIA)	0.331	533.093	
SUM		1.132	924.689	

Table 1. Walker Creek Non-Contiguous Groundwater Subbasin Characteritics - 2006 (STIA basins)

Land Use	Soil Type	% of total basin equal to EIA	D3		D8		SDE4		SDS1		SDS3		SDS3A		SDS5	
			Effective Pervious	Effective Impervious	Effective Pervious	Effective Impervious	Effective Pervious	Effective Impervious	Effective Pervious	Effective Impervious	Effective Pervious	Effective Impervious	Effective Pervious	Effective Impervious		
PERLND areas:																
(16) Till-Forest		0.01	-	1.82	-	-	-	-	-	-	141.36	-	-	-	-	18.72
(26) Till-Grass		-	-	-	-	-	-	-	-	-	-	-	-	-	-	-
(34) Outwash-Forest		-	-	1.47	-	-	-	-	-	-	-	-	-	-	-	-
(44) Outwash-Grass		-	-	-	-	-	-	-	-	-	-	-	-	-	-	-
(45) Fill		-	-	-	-	-	-	-	-	-	-	-	-	-	-	-
(54) Wetland		-	-	0.05	-	-	-	-	-	-	-	-	-	-	-	-
subtotal:		0.01	-	3.34	-	-	-	-	-	-	141.36	-	-	-	-	18.72
IMPLND areas:																
EIA		0.06	-	2.82	-	-	-	-	7.80	-	196.06	-	-	-	-	2.85
Basin total:		0.07	0.07	6.16	2.82	109.69	148.10	7.80	7.80	337.42	196.06	67.35	34.43	21.57	2.85	
Percent Impervious		85.0%	85.0%	45.8%	45.8%	74.1%	74.1%	100.0%	100.0%	58.1%	58.1%	51.1%	51.1%	13.2%	13.2%	
NETWORK FACTORS																
PERLND 16 (TF)		-	-	-	-	-	-	-	-	-	-	-	-	-	-	-
PERLND 26 (TG)		0.010	-	1.820	-	38.405	-	-	-	141.363	-	-	-	-	-	18.719
PERLND 34 (OF)		-	-	-	-	-	-	-	-	-	-	-	-	-	-	-
PERLND 44 (OG)		-	-	1.468	-	-	-	-	-	-	-	-	-	-	-	-
PERLND 45 (FL)		-	-	-	-	-	-	-	-	-	-	-	-	-	-	-
PERLND 54 (SA)		-	-	0.050	-	-	-	-	-	-	-	-	-	-	-	-
IMPLND 14 (EIA)		0.058	-	2.824	-	109.692	-	7.801	-	196.056	-	34.434	-	-	2.853	
SUM		0.069	0.069	6.162	6.162	148.097	148.097	7.801	7.801	337.419	196.056	67.350	34.434	21.572	2.853	

Table 1. Walker Creek Non-Contiguous Groundwater Subbasin Characteristics - 2006 (STIA basins)

Land Use	Soil Type	SDS6		SDS7a		SDS7b		IWS NSPS		IWS PRIMARY		MC9		IWS-NCPS	
		Effective Pervious	Effective Impervious	Effective Pervious	Effective Impervious	Effective Pervious	Effective Impervious	Effective Pervious	Effective Impervious	Effective Pervious	Effective Impervious	Effective Pervious	Effective Impervious	Effective Pervious	Effective Impervious
PERLND areas:															
(16) Till-Forest				41.21		4.32		0.31		2.51		0.51			
(26) Till-Grass		11.92													
(34) Outwash-Forest						3.93									
(44) Outwash-Grass						5.48									
(45) Fill															
(54) Wetland															
IMPLND areas:		11.92		41.21		13.73		0.31		2.51		0.51			
EIA			2.87		20.00		16.02								
Basin total:		14.79		61.21		29.75		13.75		229.98		0.51		1.13	
Percent impervious			19.4%		32.7%		53.8%		97.8%		98.9%		0.0%		100.0%
NETWORK FACTORS															
PERLND 16	(TF)														
PERLND 26	(TG)	11.922		41.207		4.320		0.307		2.508		0.514			
PERLND 34	(OF)														
PERLND 44	(OG)					3.929									
PERLND 45	(FL)					5.482									
PERLND 54	(SA)														
IMPLND 14	(EIA)	2.866		20.000		16.017		13.441		227.474				1.132	
SUM		14.788		61.207		29.748		13.747		229.982		0.514		1.132	

Walker Creek Non-Contiguous Groundwater Subbasin Characterization - 2006 (STIA basins)

Land Use	Soil Type	% of total basin equal to EIA	Areas (Acres)
PERLND areas:			TOTAL Effective Permeable
(16) Till-Forest			294.01
(26) Till-Grass			16.40
(34) Outwash-Forest			5.48
(44) Outwash-Grass			0.05
(45) Fill			304.94
(54) Wetland			
subtotal:			634.65
IMPLND areas:			TOTAL
EIA			939.59
Basin total:			5607.9%
Percent Impervious			TOTAL
NETWORK FACTORS			
PERLND 16 (TF)			294.012
PERLND 26 (TG)			5.897
PERLND 34 (OF)			5.482
PERLND 44 (OG)			0.050
PERLND 45 (FL)			634.648
PERLND 54 (SA)			939.588
IMPLND 14 (EIA)			
SUM			

AR 020248

Table 1. Des Moines Creek Surface Water Subbasin Characteristics - STIA basins)

Land Use	Soil Type	Land Use equal to EIA	Surface Water Subbasin Areas (Acres)																	
			DM-3		DM-4		DM-5		DM-6		DM-7		DM-8		DM-9					
		% of total basin	Pervious	Effective	Pervious	Effective	Pervious	Effective	Pervious	Effective	Pervious	Effective	Pervious	Effective	Pervious	Effective	Pervious	Effective		
GOMM	LAC	85%	3.09	17.51	-	-	-	-	-	-	-	-	-	-	-	-	-	-	-	
	OGF	85%	-	-	-	-	-	-	0.01	0.06	-	-	-	-	-	-	-	-	-	
	OGM	85%	-	-	0.27	1.53	-	0.00	0.00	0.02	0.65	3.68	-	2.27	12.87	-	-	-	-	
	TGF	85%	2.80	15.85	0.00	0.00	-	0.00	0.00	0.01	0.07	0.39	-	1.86	10.54	-	-	-	-	
	TGM	85%	3.29	18.63	1.44	8.13	-	-	-	-	-	-	-	-	-	-	-	-	-	
	TGS	85%	-	-	-	-	-	-	-	-	-	-	-	-	-	-	-	-	-	
F	LAC	0%	-	-	-	-	-	-	-	-	22.07	-	-	-	-	-	0.02	-	-	
	OFF	0%	-	-	-	-	-	0.02	-	-	15.40	-	-	8.58	-	-	-	-	-	
	OFM	0%	-	-	0.88	-	-	-	-	-	8.23	-	-	-	-	-	0.20	-	-	
	TFF	0%	-	-	1.59	-	0.00	-	-	-	4.21	-	-	2.43	-	-	-	-	-	
	TFM	0%	-	-	2.08	-	-	-	-	-	-	-	-	-	-	-	-	-	-	
	TFS	0%	-	-	-	-	-	-	-	-	-	-	-	-	-	-	-	-	-	
HD	LAC	30%	1.39	0.59	-	-	-	-	-	-	-	-	-	-	-	-	-	-	-	
	TGF	30%	9.67	4.14	-	-	-	-	-	-	0.96	0.41	-	-	-	-	-	-	-	
	TGM	30%	0.43	0.19	-	-	-	-	-	-	-	-	-	-	-	-	-	-	-	
	TGS	30%	-	-	-	-	-	-	-	-	-	-	-	-	-	-	-	-	-	
LD	LAC	13%	1.21	0.18	-	-	-	-	-	-	5.93	0.89	-	10.37	1.55	-	1.25	0.19	-	
	OGF	13%	-	-	-	-	-	-	-	-	37.34	5.68	-	-	-	-	8.69	1.30	-	
	OGM	13%	-	-	-	-	-	-	-	-	11.55	1.73	-	-	-	-	26.75	4.00	-	
	OGS	13%	-	-	-	-	-	-	-	-	0.09	0.01	-	-	-	-	1.04	0.16	-	
	TGF	13%	14.66	2.19	-	-	-	-	-	-	26.29	3.93	-	0.64	0.10	-	10.26	1.53	-	
	TGM	13%	7.21	1.08	-	-	-	-	-	-	-	-	-	-	-	-	2.89	0.43	-	
OG	LAC	0%	-	-	-	-	-	-	-	-	-	-	-	-	-	-	-	-	-	
	OGF	0%	-	-	-	-	-	-	8.49	-	-	-	-	-	-	-	-	-	-	
	OGM	0%	-	-	0.18	-	-	-	-	-	-	-	-	-	-	-	-	-	-	
	TGF	0%	-	-	0.51	-	-	-	-	-	-	-	-	-	-	-	-	-	-	
	TGM	0%	-	-	1.96	-	-	-	4.83	-	-	-	-	-	-	-	-	-	-	
	TGS	0%	-	-	0.79	-	-	-	1.57	-	-	-	-	-	-	-	-	-	-	
STIA	LAC	0%	-	-	-	-	-	-	-	-	-	-	-	-	-	-	-	-	-	
	OGF	0%	-	-	-	-	-	-	-	-	-	-	-	-	-	-	-	-	-	
	OGM	0%	-	-	-	-	-	-	-	-	-	-	-	-	-	-	-	-	-	
	TGF	0%	-	-	0.16	0.01	-	-	-	-	-	-	-	-	-	-	-	-	-	
	TGM	0%	-	-	1.57	0.07	-	-	-	-	-	-	-	-	-	-	-	-	-	
	TGS	0%	-	-	-	-	-	-	-	-	-	-	-	-	-	-	-	-	-	
TRANS	OGF	0%	-	-	-	-	-	-	-	-	-	-	-	0.94	0.03	-	-	-	-	
	TGF	0%	-	-	-	-	-	-	-	-	-	-	-	4.81	3.95	-	-	-	-	

Table 1. Des Moines Creek Surface Water Subbasin Characteristics -1 (STIA basins)

Land Use		Surface Water Subbasin Areas (Acres)													
		DM-3		DM-4		DM-5		DM-6		DM-7		DM-8		DM-9	
Land Use	Soil Type	Effective Pervious	Effective Impervious	Effective Pervious	Effective Impervious	Effective Pervious	Effective Impervious	Effective Pervious	Effective Impervious	Effective Pervious	Effective Impervious	Effective Pervious	Effective Impervious	Effective Pervious	Effective Impervious
Wetland	0%	0.16	0.06	1.35	3.74	6.62	1.93	0.12							
Lake		-	-	-	0.03	-	-	-	-	-	-	-	-	-	-
Other		0.07	0.02	-	-	0.01	0.01	-	-	-	-	-	-	-	-
Basin total:	% of total basin equal to EIA	43.91	60.36	11.18	9.74	141.55	33.83	51.22	28.79	29.04	58.82	12.9%	7.60		
PERLND areas:															
(16) TF		-	3.49	2.08	0.00	26.28	2.43	0.02							
(26) TG		43.74	7.07	5.91	6.41	35.33	7.31	14.40							
(34) OF		-	-	0.88	0.02	23.63	8.58	0.20							
(44) OG		-	-	0.96	8.50	49.70	13.58	36.48							
(54) Wetland		0.16	0.06	1.35	3.74	6.62	1.93	0.12							
subtotal:		43.91	10.62	11.18	18.68	141.55	33.83	51.22							
IMPLND areas:															
EIA		60.36	40.08	9.74	0.09	28.79	29.04	7.60							
Basin total:		104.27	50.70	20.92	18.77	170.34	62.87	58.82	16.9%	48.2%	12.9%				
Percent Impervious		57.9%	79.0%	46.6%	0.5%	16.9%	48.2%	12.9%							
NETWORK FACTORS															
PERLND 16 (TF)		-	0.291	0.173	0.000	2.190	0.203	0.002							
PERLND 26 (TG)		3.645	0.589	0.493	0.534	2.944	0.809	1.200							
PERLND 34 (OF)		-	-	0.074	0.002	1.969	0.715	0.016							
PERLND 44 (OG)		-	-	0.080	0.709	4.142	1.132	3.040							
PERLND 54 (SA)		0.013	0.005	0.112	0.312	0.551	0.161	0.010							
IMPLND 14 (EIA)		5.030	3.340	0.812	0.008	2.399	2.420	0.634							
SUM		8.689	4.225	1.743	1.564	14.195	5.239	4.902							

Table 1. Des Moines Creek Surface Water Subbasin Characteristics - 11 STIA basins)

Land Use	Soil Type	% of total basin equal to EIA	Surface Water Subbasin Areas (Acres)													
			DM-10		DM-11		DM-12		DM-13		SDE-4		SDS-1		SDS-2	
			Pervious	Effective Impervious	Pervious	Effective Impervious	Pervious	Effective Impervious	Pervious	Effective Impervious	Pervious	Effective Impervious	Pervious	Effective Impervious	Pervious	Effective Impervious
COMM	LAC	85%	-	1.12	6.35	-	-	-	-	-	-	-	-	-	-	-
	OGF	85%	-	2.89	16.37	-	-	-	-	-	-	-	-	-	-	-
	OGM	85%	-	-	-	-	-	-	-	-	-	-	-	-	-	-
	TGF	85%	-	1.36	7.72	-	-	-	-	-	-	-	-	-	-	-
	TGM	85%	-	-	-	-	-	-	-	-	-	-	-	-	-	-
	TGS	85%	-	-	-	-	-	-	-	-	-	-	-	-	-	-
F	LAG	0%	11.16	0.73	-	6.13	-	-	-	-	-	-	-	-	-	-
	OFF	0%	8.80	12.28	-	0.02	-	-	-	-	-	-	-	-	-	-
	OFM	0%	14.42	-	-	4.48	-	-	-	-	-	-	-	-	-	-
	TFF	0%	0.18	3.12	-	-	-	-	-	-	-	-	-	-	-	-
	TFM	0%	-	-	-	-	-	-	-	-	-	-	-	-	-	-
	TFS	0%	-	-	-	-	-	-	-	-	-	-	-	-	-	-
HD	LAC	30%	-	-	-	-	-	-	-	-	-	-	-	-	-	-
	TGF	30%	-	-	-	-	-	-	-	-	-	-	-	-	-	-
	TGM	30%	-	-	-	-	-	-	-	-	-	-	-	-	-	-
	TGS	30%	-	-	-	-	-	-	-	-	-	-	-	-	-	-
LD	LAC	13%	2.50	0.37	-	-	-	-	-	-	-	-	-	-	-	-
	OGF	13%	0.67	0.10	-	-	-	-	-	-	-	-	-	-	-	-
	OGM	13%	5.39	0.81	-	-	-	-	-	-	-	-	-	-	-	-
	OGS	13%	-	-	-	-	-	-	-	-	-	-	-	-	-	-
	TGF	13%	6.33	0.95	-	-	-	-	-	-	-	-	-	-	-	-
	TGM	13%	-	-	-	-	-	-	-	-	-	-	-	-	-	-
OG	LAC	0%	0.02	-	-	0.01	-	-	-	-	-	-	-	-	-	-
	OGF	0%	0.06	-	-	18.95	-	-	-	-	-	-	-	-	-	-
	OGM	0%	0.00	-	-	1.93	-	-	-	-	-	-	-	-	-	-
	TGF	0%	-	-	-	-	-	-	-	-	-	-	-	-	-	-
	TGM	0%	-	1.42	-	-	-	-	-	-	-	-	-	-	-	-
	TGS	0%	-	-	-	-	-	-	-	-	-	-	-	-	-	-
STIA	LAC	0%	-	-	-	-	-	-	-	-	-	-	-	-	-	-
	OGF	0%	-	-	-	-	-	-	-	-	-	-	-	-	-	-
	OGM	0%	-	-	-	-	-	-	-	-	-	-	-	-	-	-
	TGF	0%	-	-	-	-	-	-	-	-	-	-	-	-	-	-
	TGM	0%	-	-	-	-	-	-	-	-	-	-	-	-	-	-
	TGS	0%	-	-	-	-	-	-	-	-	-	-	-	-	-	-
TRANS	OGF	0%	-	0.99	-	-	-	-	-	-	-	-	-	-	-	-
	TGF	0%	-	2.27	-	-	-	-	-	-	-	-	-	-	-	-

Table 4. Des Moines Creek Surface Water Subbasin Characteristics - 11 STIA basins)

Land Use		Surface Water Subbasin Areas (Acres)													
Land Use	Soil Type	DM-10		DM-11		DM-12		DM-13		SDE-4		SDS-1		SDS-2	
		Pervious	Effective Impervious	Pervious	Effective Impervious	Pervious	Effective Impervious	Pervious	Effective Impervious	Pervious	Effective Impervious	Pervious	Effective Impervious	Pervious	Effective Impervious
Wetland	0%	8.55	12.43	6.51	0.30	0.00	0.85	0.07	0.13	-	-	-	-	-	0.52
Lake		0.97	5.33	0.63	0.85	0.00	0.85	0.07	0.13	-	-	-	-	-	-
Other		0.00	-	0.00	0.07	0.00	0.07	0.07	0.13	-	-	-	-	-	-
Basin total:		58.08	2.22	39.06	32.71	38.02	15.11	67.10	15.11	50.75	115.49	0.93	16.81	7.66	1.49
PERLND areas:															
(16) TF		11.34	3.85	6.13	11.53	6.13	18.74	11.53	50.75	-	-	-	-	2.76	-
(26) TG		8.85	4.89	0.01	18.74	0.01	14.44	18.74	50.75	-	-	0.93	0.93	0.17	-
(34) OF		23.22	12.28	4.50	22.10	4.50	20.88	22.10	-	-	-	-	-	4.06	-
(44) OG		6.12	5.61	20.88	0.30	6.51	67.10	0.30	-	-	-	-	-	0.15	-
(54) Wetland		8.55	12.43	6.51	67.10	6.51	38.02	67.10	50.75	-	-	0.93	0.93	0.52	-
subtotal:		58.08	39.06	38.02	67.10	38.02	15.11	67.10	50.75	-	-	0.93	16.81	7.66	1.49
IMPLND areas:															
EIA		2.22	32.71	0.00	0.00	0.00	15.11	0.00	115.49	-	-	-	-	-	-
Basin total:		60.30	71.77	38.02	82.22	38.02	18.4%	82.22	166.24	166.24	69.5%	17.74	94.8%	9.15	16.3%
Percent Impervious		3.7%	45.6%	0.0%	18.4%	0.0%	18.4%	18.4%	69.5%	69.5%	94.8%	17.74	94.8%	9.15	16.3%
NETWORK FACTORS															
PERLND 16 (TF)		0.945	0.321	0.510	0.961	0.510	1.562	0.961	4.229	-	-	-	-	0.230	-
PERLND 26 (TG)		0.738	0.408	0.001	1.562	0.001	1.203	1.562	4.229	-	-	0.077	0.077	0.014	-
PERLND 34 (OF)		1.835	1.024	0.375	1.842	0.375	1.842	1.842	-	-	-	-	-	0.338	-
PERLND 44 (OG)		0.510	0.467	1.740	0.025	1.740	0.025	0.025	-	-	-	-	-	0.012	-
PERLND 54 (SA)		0.712	1.036	0.543	1.259	0.543	1.259	1.259	9.624	-	-	1.401	1.401	0.043	-
IMPLND 14 (EIA)		0.185	2.726	3.168	6.851	3.168	6.851	6.851	13.853	-	-	1.478	1.478	0.124	-
SUM		5.025	5.981	3.168	6.851	3.168	6.851	6.851	13.853	13.853	16.3%	1.478	16.3%	0.762	1.49

Table 4. Des Moines Creek Surface Water Subbasin Characteristics - 11 STIA basins)

Land Use		Surface Water Subbasin Areas (Acres)													
Land Use	Soil Type	SDS-3		SDS-3A		SDS-4		SDS-5		SDS-6		SDS-7		SASA	
		Pervious	Effective Impervious	Pervious	Effective Impervious	Pervious	Effective Impervious	Pervious	Effective Impervious	Pervious	Effective Impervious	Pervious	Effective Impervious	Pervious	Effective Impervious
COMM	LAC	85%	-	-	-	-	-	-	-	-	-	-	-	-	-
	OGF	85%	-	-	-	-	-	-	-	-	-	-	-	-	-
	OGM	85%	-	-	0.02	0.10	-	-	-	-	-	-	-	-	0.01
	TGF	85%	-	-	-	-	-	-	-	-	-	-	-	-	1.37
	TGM	85%	0.00	-	0.00	0.00	-	-	-	-	-	-	-	-	0.19
	TGS	85%	-	-	-	-	-	-	-	-	-	-	-	-	-
F	LAC	0%	-	-	-	-	-	-	-	-	-	-	-	-	-
	OFF	0%	-	-	-	-	-	-	-	-	-	-	-	-	-
	OFM	0%	-	-	0.14	-	-	-	-	-	-	-	-	-	-
	TFF	0%	-	-	-	-	-	-	-	-	-	-	-	-	0.23
	TFM	0%	-	-	0.00	-	-	-	-	-	-	-	-	-	12.32
	TFS	0%	-	-	-	-	-	-	-	-	-	-	-	-	9.89
	TFS	0%	-	-	-	-	-	-	-	-	-	-	-	-	0.58
HD	LAC	30%	-	-	-	-	-	-	-	-	-	-	-	-	-
	TGF	30%	-	-	-	-	-	-	-	-	-	-	-	-	-
	TGM	30%	-	-	-	-	-	-	-	-	-	-	-	-	-
	TGS	30%	-	-	-	-	-	-	-	-	-	-	-	-	-
LD	LAC	13%	-	-	-	-	-	-	-	-	-	-	-	-	-
	OGF	13%	-	-	-	-	-	-	-	-	-	-	-	-	-
	OGM	13%	-	-	-	-	-	-	-	-	-	-	-	-	-
	OGS	13%	-	-	-	-	-	-	-	-	-	-	-	-	-
	TGF	13%	-	-	-	-	-	-	-	-	-	-	-	-	-
	TGM	13%	-	-	-	-	-	-	-	-	-	-	-	-	-
OG	LAC	0%	-	-	-	-	-	-	-	-	-	-	-	-	-
	OGF	0%	-	-	-	-	-	-	-	-	-	-	-	-	-
	OGM	0%	-	-	25.08	0.61	-	-	-	-	-	-	-	-	4.59
	TGF	0%	-	-	0.61	2.94	-	-	-	-	-	-	-	-	49.88
	TGM	0%	-	-	0.00	0.00	-	-	-	1.31	-	-	-	-	2.01
	TGS	0%	-	-	-	-	-	-	-	-	-	-	-	-	1.91
OG	LAC	0%	-	-	-	-	-	-	-	-	-	-	-	-	-
	OGF	0%	-	-	-	-	-	-	-	-	-	-	-	-	-
	OGM	0%	-	-	-	-	-	-	-	-	-	-	-	-	-
	TGF	0%	-	-	-	-	-	-	-	-	-	-	-	-	-
	TGM	0%	-	-	-	-	-	-	-	-	-	-	-	-	-
	TGS	0%	-	-	-	-	-	-	-	-	-	-	-	-	0.19
STIA	LAC	0%	-	-	-	-	-	-	-	-	-	-	-	-	-
	OGF	0%	-	-	-	-	-	-	-	-	-	-	-	-	-
	OGM	0%	-	-	9.98	11.40	-	-	-	-	-	-	-	-	-
	TGF	0%	-	-	0.45	1.79	-	-	-	-	-	-	-	-	-
	TGM	0%	160.43	170.75	6.17	5.91	31.99	0.39	4.27	11.12	20.55	6.52	-	-	
	TGS	0%	5.07	7.04	4.43	2.63	-	-	-	-	0.23	0.03	-	-	
TRANS	OGF	0%	-	-	-	-	-	-	-	-	-	-	-	-	-
	TGF	0%	-	-	0.01	-	0.08	-	0.00	0.03	-	-	-	-	-

Table 1. Des Moines Creek Surface Water Subbasin Characteristics - (11 TIA basins)

Land Use		Surface Water Subbasin Areas (Acres)													
Land Use Type	Soil Type	SDS-3		SDS-3A		SDS-4		SDS-5		SDS-6		SDS-7		SASA	
		Pervious	Effective Impervious	Pervious	Effective Impervious	Pervious	Effective Impervious	Pervious	Effective Impervious	Pervious	Effective Impervious	Pervious	Effective Impervious	Pervious	Effective Impervious
Welland	0%	-	0.00	-	0.00	-	0.00	-	-	-	-	0.39	-	-	0.54
Lake		-	-	-	-	-	-	-	-	-	-	-	-	-	-
Other		-	-	-	-	-	-	-	-	-	-	-	-	-	-
Basin total:		165.49	177.79	62.72	7.05	45.37	19.19	32.07	0.39	12.46	4.27	83.24	8.01	25.33	8.94
PERLND areas:															
(16) TF		-	-	-	-	0.00	-	-	-	-	-	-	-	22.79	-
(26) TG		165.49	-	62.72	62.72	9.13	0.00	32.07	0.39	12.46	4.27	78.26	8.01	1.76	-
(34) OF		-	-	-	-	0.14	-	-	-	-	-	-	-	0.23	-
(44) OG		-	-	-	-	36.11	-	-	-	-	-	4.59	-	0.01	-
(54) Welland		-	-	-	-	0.00	-	-	-	-	-	0.39	-	0.54	-
subtotal:		165.49	-	62.72	62.72	45.37	19.19	32.07	0.39	12.46	4.27	83.24	8.01	25.33	-
IMPLND areas:															
EIA		-	-	-	-	-	-	-	-	-	-	-	-	-	-
Basin total:		343.28	177.79	69.78	7.05	64.57	19.19	32.46	0.39	16.72	4.27	91.25	8.01	34.27	8.94
Percent Impervious		51.8%	51.8%	10.1%	10.1%	29.7%	29.7%	32.46	1.2%	25.5%	25.5%	8.8%	8.8%	26.1%	26.1%
NETWORK FACTORS															
PERLND 16 (TF)		-	-	-	-	0.000	-	-	-	-	-	-	-	1.899	-
PERLND 26 (TG)		13.791	-	5.227	5.227	0.761	0.000	2.672	0.39	1.038	4.27	6.522	8.01	0.146	-
PERLND 34 (OF)		-	-	-	-	0.011	-	-	-	-	-	-	-	0.019	-
PERLND 44 (OG)		-	-	-	-	3.009	-	-	-	-	-	0.383	-	0.001	-
PERLND 54 (SA)		-	-	-	-	0.000	-	-	-	-	-	0.033	-	0.045	-
IMPLND 14 (EIA)		14.816	-	0.588	0.588	1.588	0.000	0.032	0.39	0.356	4.27	0.668	8.01	0.745	-
SUM		28.607	14.816	5.815	5.815	5.380	1.588	2.705	0.39	1.394	4.27	7.605	8.01	2.856	-

Table 1. Des Moines Creek Surface Water Subbasin Characteristics - STIA basins)

Land Use	Soil Type	% of total basin equal to EIA	Surface Water Subbasin Areas (Acres)												
			IWS NSPS		IWS PRIMARY		IWS WEST		IWS SASA		Total				
			Pervious	Effective Impervious	Pervious	Effective Impervious	Pervious	Effective Impervious	Pervious	Effective Impervious	Pervious	Effective Impervious			
COMM	LAC	85%	-	-	-	-	-	-	-	-	-	7.64	43.27	0.40%	2.26%
	OGF	85%	-	-	-	-	-	-	0.01	0.04	-	5.98	33.86	0.31%	1.77%
	OGM	85%	-	-	-	-	-	0.45	2.53	-	0.82	4.65	0.04%	0.24%	
	TGF	85%	-	0.23	1.30	-	-	0.02	0.13	-	16.48	93.39	0.86%	4.88%	
	TGM	85%	-	0.08	0.48	-	-	0.02	2.73	-	9.18	52.01	0.48%	2.72%	
	TGS	85%	-	-	-	-	-	0.20	1.15	-	0.20	1.15	0.01%	0.06%	
F	LAC	0%	-	-	-	-	-	-	-	-	40.10	-	-	2.09%	0.00%
	OFF	0%	-	-	-	6.14	-	-	0.04	-	55.49	-	-	2.90%	0.00%
	OFM	0%	-	-	-	-	-	0.20	-	-	43.06	-	-	2.25%	0.00%
	TFF	0%	-	-	-	2.67	-	-	1.08	-	35.31	-	-	1.84%	0.00%
	TFM	0%	-	-	-	-	-	-	28.69	-	48.90	-	-	2.55%	0.00%
	TFS	0%	-	-	-	-	-	-	6.80	-	7.61	-	-	0.40%	0.00%
HD	LAC	30%	-	-	-	-	-	-	-	-	1.39	0.59	0.07%	0.03%	
	TGF	30%	-	-	-	-	-	-	-	-	11.64	4.99	0.61%	0.26%	
	TGM	30%	-	-	-	-	-	-	-	-	1.58	0.68	0.08%	0.04%	
	TGS	30%	-	-	-	-	-	-	-	-	1.29	0.55	0.07%	0.03%	
LD	LAC	13%	-	-	-	-	-	-	-	-	10.90	1.63	0.57%	0.09%	
	OGF	13%	-	-	-	-	-	-	-	-	58.54	8.75	3.06%	0.46%	
	OGM	13%	-	-	-	-	-	-	-	-	43.72	6.53	2.28%	0.34%	
	OGS	13%	-	-	-	-	-	-	-	-	1.13	0.17	0.06%	0.01%	
	TGF	13%	-	-	-	-	-	-	-	-	58.18	8.69	3.04%	0.45%	
	TGM	13%	-	-	-	-	-	-	-	-	10.10	1.51	0.53%	0.08%	
OG	LAC	0%	-	-	-	-	-	-	-	-	0.03	-	-	0.00%	0.00%
	OGF	0%	-	-	-	-	-	-	0.09	-	78.41	-	-	3.99%	0.00%
	OGM	0%	-	-	-	-	-	-	2.71	-	10.10	-	-	0.53%	0.00%
	TGF	0%	-	0.05	-	-	-	-	0.32	-	82.82	-	-	4.32%	0.00%
	TGM	0%	-	0.12	-	-	-	-	9.01	-	22.36	-	-	1.17%	0.00%
	TGS	0%	-	-	-	-	-	-	-	-	1.91	-	-	0.10%	0.00%
STIA	LAC	0%	-	-	-	-	-	-	-	-	0.78	0.11	0.04%	0.01%	
	OGF	0%	-	-	-	-	-	-	-	-	9.96	11.40	0.52%	0.60%	
	OGM	0%	-	-	-	-	-	-	0.37	0.00	0.82	1.79	0.04%	0.09%	
	TGF	0%	0.31	13.44	11.95	225.09	0.44	2.72	-	-	330.42	539.50	17.25%	28.17%	
	TGM	0%	-	-	0.96	6.61	-	-	-	-	19.66	17.28	1.03%	0.90%	
	TGS	0%	-	-	-	-	-	-	-	-	0.28	0.01	0.01%	0.00%	
TRANS	OGF	0%	-	-	-	-	-	-	-	-	0.94	0.03	0.05%	0.00%	
	TGF	0%	-	-	-	-	-	-	-	-	6.04	6.58	0.32%	0.34%	

Table 1. Des Moines Creek Surface Water Subbasin Characteristics - 15 TIA basins)

Land Use	Surface Water Subbasin Areas (Acres)								Percent of Total Effective Impervious	
	IWS NSPS		IWS PRIMARY		IWS WEST		IWS SASA			
	Pervious	Effective Impervious	Pervious	Effective Impervious	Pervious	Effective Impervious	Pervious	Effective Impervious		
Wetland	-	-	-	-	0.00	-	1.35	-	44.58	2.33%
Lake	-	-	-	-	6.65	-	-	-	14.45	0.75%
Other	-	-	-	-	-	-	-	-	0.31	0.02%
Basin total:	0.31	13.44	13.40	233.48	11.53	0.44	51.82	6.57	1076.33	56.19%
PERLND areas:										
(16) TF	-	-	-	-	2.67	-	36.57	-	131.93	6.89%
(26) TG	0.31	-	13.40	-	2.72	-	10.04	-	592.87	30.95%
(34) OF	-	-	-	-	6.14	-	0.24	-	98.55	5.14%
(44) OG	-	-	-	-	-	-	3.63	-	208.41	10.88%
(54) Wetland subtotal:	-	-	-	-	0.00	-	1.35	-	44.58	2.33%
IMPLND areas:										
EIA	0.31	13.44	13.40	233.48	11.53	0.44	51.82	6.57	1076.33	56.19%
Basin total:	13.75	97.8%	246.87	94.6%	11.97	3.7%	58.40	11.3%	1915.44	100.00%
Percent impervious										
NETWORK FACTORS										
PERLND 16 (TF)	-	-	-	-	0.222	-	3.047	-	10.994	6.89%
PERLND 26 (TG)	0.026	-	1.117	-	0.226	-	0.837	-	49.405	30.95%
PERLND 34 (OF)	-	-	-	-	0.512	-	0.020	-	8.212	5.14%
PERLND 44 (OG)	-	-	-	-	-	-	0.302	-	17.368	10.88%
PERLND 54 (SA)	-	-	-	-	0.000	-	0.113	-	3.715	2.33%
IMPLND 14 (EIA)	1.120	-	19.456	-	0.037	-	0.548	-	69.926	43.81%
SUM	1.146		20.573		0.997		4.866		159.620	100.00%

Table 1. Des Moines Creek Surface Water Subbasin Characteristics - 2C (STIA basins)

Land Use	Soil Type	basin equal to EIA	Surface Water Subbasin Areas (Acres)													
			DM-3		DM-4		DM-5		DM-6		DM-7		DM-8		DM-9	
		% of total	Pervious	Effective	Pervious	Effective	Pervious	Effective	Pervious	Effective	Pervious	Effective	Pervious	Effective	Pervious	Effective
GOMM	LAG	85%	3.09	17.52	-	-	-	-	0.01	0.06	2.15	12.17	-	-	-	-
	OGF	85%	-	-	-	-	-	0.01	0.06	0.65	3.70	-	-	-	-	-
	OGM	85%	-	-	0.27	1.53	-	0.00	0.02	0.07	0.39	-	-	2.28	12.89	-
	TGF	85%	2.54	14.37	0.00	0.00	-	0.00	0.02	-	-	-	-	-	-	-
	TGM	85%	2.44	13.83	1.37	7.79	-	-	-	-	-	-	1.86	10.54	-	-
F	LAG	0%	-	-	-	-	-	-	-	22.07	-	-	-	-	-	-
	OFF	0%	-	-	-	-	-	0.02	-	15.40	-	-	-	-	-	-
	OFM	0%	-	-	0.88	-	-	-	-	8.23	-	-	8.58	-	-	-
	TFF	0%	-	-	-	-	-	-	-	4.21	-	-	2.43	-	-	-
	TFM	0%	-	-	2.07	-	-	-	-	-	-	-	-	-	-	-
	TFS	0%	-	-	-	-	-	-	-	-	-	-	-	-	-	-
HD	LAG	30%	1.39	0.59	-	-	-	-	-	-	-	-	-	-	-	-
	TGF	30%	9.67	4.15	-	-	-	-	-	0.96	0.41	-	-	-	-	-
	TGM	30%	0.43	0.19	-	-	-	-	-	-	-	-	-	-	-	-
LD	LAC	13%	1.21	0.18	-	-	-	-	-	5.93	0.89	-	-	-	1.25	0.19
	OGF	13%	-	-	-	-	-	-	-	37.35	5.58	-	-	10.37	8.69	1.30
	OGM	13%	-	-	-	-	-	-	-	11.55	1.73	-	-	-	26.75	4.00
	OGS	13%	-	-	-	-	-	-	-	0.09	0.01	-	-	-	1.04	0.16
	TGF	13%	14.66	2.19	-	-	-	-	-	26.29	3.93	-	-	0.64	10.27	1.53
	TGM	13%	7.21	1.08	-	-	-	-	-	-	-	-	-	-	2.89	0.43
OG	LAC	0%	-	-	-	-	-	-	-	-	-	-	-	-	-	-
	OGF	0%	-	-	0.15	-	-	8.49	-	-	-	-	-	-	-	-
	OGM	0%	-	-	0.51	-	-	-	-	-	-	-	-	-	-	-
	TGF	0%	-	-	1.97	-	-	4.83	-	-	-	-	-	-	-	-
	TGM	0%	-	-	0.78	-	-	1.57	-	-	-	-	-	-	-	-
STIA	FLF	0%	-	-	-	-	-	-	-	-	-	-	-	-	-	-
	LAC	0%	-	-	-	-	-	-	-	-	-	-	-	-	-	-
	OGF	0%	-	-	-	-	-	-	-	-	-	-	-	-	-	-
	OGM	0%	-	-	0.00	0.03	-	-	-	-	-	-	-	-	-	-
	OGS	0%	-	-	0.00	0.00	-	-	-	-	-	-	-	-	-	-
	TGF	0%	-	-	0.16	0.00	-	-	-	-	-	-	-	-	-	-
	TGM	0%	-	-	1.53	0.24	-	-	-	-	-	-	-	-	-	-
	TGS	0%	-	-	-	-	-	-	-	-	-	-	-	-	-	-
TRANS	OGF	0%	-	-	-	-	-	-	-	-	-	-	0.95	0.03	-	-
	OGM	0%	-	-	-	-	-	-	-	-	-	-	-	-	-	-
	TGF	0%	-	-	-	-	-	-	-	-	-	-	4.81	3.95	-	-

Table 1. Des Moines Creek Surface Water Subbasin Characteristics -21- (3 TIA basins)

Land Use	Surface Water Subbasin Areas (Acres)													
	DM-3		DM-4		DM-5		DM-6		DM-7		DM-8		DM-9	
	Pervious	Effective Impervious	Pervious	Effective Impervious	Pervious	Effective Impervious	Pervious	Effective Impervious	Pervious	Effective Impervious	Pervious	Effective Impervious	Pervious	Effective Impervious
Wetland	0.07	0%	0.06	0.06	1.35	3.74	6.62	1.93	0.12	-	-	-	-	-
Lake	-	-	-	-	-	0.03	-	-	-	-	-	-	-	-
Sasa-dp	7.42	-	-	-	0.28	-	-	-	-	-	-	-	-	-
Other	0.00	-	0.06	-	-	-	0.01	-	-	-	-	-	-	-
Basin total:	42.72	54.10	10.56	40.28	11.05	18.67	28.81	33.84	51.23	141.59	29.06	58.83	7.60	7.60
PERLND areas:														
(16) TF	-	-	3.43	-	2.07	-	-	26.28	0.02	26.28	2.43	0.02	0.02	0.02
(26) TG	42.65	-	7.09	-	5.82	6.41	35.33	7.31	14.41	35.33	8.58	14.41	14.41	14.41
(34) OF	-	-	-	-	0.88	0.02	23.63	8.58	0.20	23.63	8.58	0.20	0.20	0.20
(44) OG	-	-	-	-	0.93	8.50	49.72	13.59	36.48	49.72	13.59	36.48	36.48	36.48
(45) FL	-	-	-	-	-	-	-	-	-	-	-	-	-	-
(54) Wetland	0.07	-	0.06	-	1.35	3.74	6.62	1.93	0.12	6.62	1.93	0.12	0.12	0.12
subtotal:	42.72	-	10.56	-	11.05	18.67	141.59	33.84	51.23	141.59	29.06	58.83	7.60	7.60
IMPLND areas:														
EIA	96.82	54.10	50.87	40.28	20.64	18.75	28.81	62.90	58.83	170.40	29.06	58.83	7.60	7.60
Basin total:	96.82	54.10	50.87	40.28	20.64	18.75	28.81	62.90	58.83	170.40	29.06	58.83	7.60	7.60
Percent Impervious	55.9%	55.9%	79.2%	46.5%	16.9%	46.2%	12.9%	12.9%	12.9%	12.9%	12.9%	12.9%	12.9%	12.9%
NETWORK FACTORS														
PERLND 16 (TF)	-	-	0.286	-	0.173	-	-	2.190	0.002	2.190	0.203	0.002	0.002	0.002
PERLND 26 (TG)	3.554	-	0.591	-	0.485	0.534	2.944	0.609	1.201	2.944	0.609	1.201	1.201	1.201
PERLND 34 (OF)	-	-	-	-	0.074	0.002	1.970	0.715	0.017	1.970	0.715	0.017	0.017	0.017
PERLND 44 (OG)	-	-	-	-	0.077	0.709	4.143	1.133	3.040	4.143	1.133	3.040	3.040	3.040
PERLND 45 (FL)	-	-	-	-	-	-	-	-	-	-	-	-	-	-
PERLND 54 (SA)	0.006	-	0.005	-	0.112	0.312	0.552	0.161	0.010	0.552	0.161	0.010	0.010	0.010
IMPLND 14 (EIA)	4.508	-	3.357	-	0.799	0.007	2.401	2.422	0.634	2.401	2.422	0.634	0.634	0.634
SUM	8.088	8.088	4.239	4.239	1.720	1.563	14.200	5.242	4.903	14.200	5.242	4.903	4.903	4.903

Table 1. Des Moines Creek Surface Water Subbasin Characteristics -21 (STIA basins)

Land Use	Soil Type	% of total basin equal to EIA	Surface Water Subbasin Areas (Acres)													
			DM-10		DM-11		DM-12		DM-13		SDE-4		SDS-1		SDS-2	
			Pervious	Effective Impervious	Pervious	Effective Impervious	Pervious	Effective Impervious	Pervious	Effective Impervious	Pervious	Effective Impervious	Pervious	Effective Impervious	Pervious	Effective Impervious
COMM	LAC	85%	-	-	1.12	6.35	-	-	-	-	-	-	-	-	-	-
	OGF	85%	-	-	2.89	16.37	-	-	-	-	-	-	-	-	-	-
	OGM	85%	-	-	-	-	-	-	-	-	-	-	-	-	-	-
	TGM	85%	-	-	1.36	7.72	-	-	-	2.59	14.66	-	-	-	-	-
F	LAC	0%	-	11.16	-	-	-	-	-	-	-	-	-	-	-	-
	OFF	0%	-	8.80	-	-	6.13	-	0.00	-	-	-	-	-	-	-
	OFM	0%	-	14.42	-	-	0.02	-	0.02	-	-	-	-	-	-	-
	TFF	0%	-	0.18	-	-	4.48	-	14.42	-	-	-	-	-	-	-
	TFS	0%	-	-	-	-	-	-	4.94	6.35	-	-	-	-	-	-
HD	LAC	30%	-	-	-	-	-	-	-	-	-	-	-	-	-	-
	TGF	30%	-	-	-	-	-	-	0.06	0.02	-	-	-	-	-	-
	TGM	30%	-	-	-	-	-	-	-	-	-	-	-	-	-	-
LD	LAC	13%	-	2.50	-	-	0.37	-	-	-	-	-	-	-	-	-
	OGF	13%	-	0.67	-	-	0.10	-	-	-	-	-	-	-	-	-
	OGM	13%	-	5.39	-	-	0.81	-	1.47	0.22	-	-	-	-	-	-
	OGS	13%	-	-	-	-	-	-	0.04	0.01	-	-	-	-	-	-
	TGM	13%	-	6.33	-	-	0.95	-	-	-	-	-	-	-	-	-
OG	LAC	0%	-	0.02	-	-	-	-	-	-	-	-	-	-	-	-
	OGF	0%	-	0.06	-	-	-	-	15.48	-	-	-	-	-	-	-
	OGM	0%	-	0.00	-	-	-	-	4.35	-	-	-	-	-	-	-
	TGF	0%	-	-	-	-	-	-	9.55	-	-	-	-	-	-	-
	TGM	0%	-	-	-	-	-	-	6.52	-	-	-	-	-	-	-
STIA	FLF	0%	-	-	-	-	-	-	-	-	-	-	-	-	-	-
	LAC	0%	-	-	-	-	-	-	-	-	-	-	-	-	-	-
	OGF	0%	-	-	-	-	-	-	-	-	-	-	-	-	-	-
	OGM	0%	-	-	-	-	-	-	-	-	-	-	-	-	-	-
	TGM	0%	-	-	-	-	-	-	-	-	-	-	-	-	-	-
TRANS	OGF	0%	-	-	-	-	-	-	-	-	-	-	-	-	-	-
	OGM	0%	-	-	-	-	-	-	-	-	-	-	-	-	-	-
	TGF	0%	-	-	-	-	-	-	-	-	-	-	-	-	-	-
	TGM	0%	-	-	-	-	-	-	-	-	-	-	-	-	-	-
	TGS	0%	-	-	-	-	-	-	-	-	-	-	-	-	-	-
Totals			0.99	2.27	0.00	1.93	0.01	18.81	0.00	0.00	0.00	0.00	0.00	0.00	0.00	0.00

Table 1. Des Moines Creek Surface Water Subbasin Characteristics -2 (STIA basins)

Land Use		Surface Water Subbasin Areas (Acres)													
Land Use	Soil Type	DM-10		DM-11		DM-12		DM-13		SDE-4		SDS-1		SDS-2	
		Pervious	Effective Impervious	Pervious	Effective Impervious	Pervious	Effective Impervious	Pervious	Effective Impervious	Pervious	Effective Impervious	Pervious	Effective Impervious	Pervious	Effective Impervious
Wetland	0%	8.55	12.43	6.65	1.07	6.65	1.07	6.65	1.07	6.65	1.07	6.65	1.07	6.65	1.07
Lake		0.97	5.33	0.63	0.85	0.63	0.85	0.63	0.85	0.63	0.85	0.63	0.85	0.63	0.85
Sasa-dp		-	-	-	-	-	-	-	-	0.03	-	0.04	-	-	-
Other		0.00	-	0.00	0.07	0.00	0.07	0.00	0.07	0.13	-	-	-	-	-
Basin total:		58.08	39.06	38.02	67.13	38.02	15.11	38.02	15.11	40.12	126.09	1.39	16.32	8.12	1.03
PERLND areas:															
(16) TF		11.34	3.85	6.13	11.53	6.13	11.53	6.13	11.53	40.12	126.09	1.39	16.32	8.12	1.03
(26) TG		8.85	4.89	0.01	18.75	0.01	18.75	0.01	18.75	40.12	126.09	1.39	16.32	8.12	1.03
(34) OF		23.22	12.28	4.50	14.44	4.50	14.44	4.50	14.44	40.12	126.09	1.39	16.32	8.12	1.03
(44) OG		6.12	5.61	20.73	21.33	20.73	21.33	20.73	21.33	40.12	126.09	1.39	16.32	8.12	1.03
(45) FL		-	-	-	-	-	-	-	-	-	-	-	-	-	-
(54) Welland subtotal:		8.55	12.43	6.65	1.07	6.65	1.07	6.65	1.07	40.12	126.09	1.39	16.32	8.12	1.03
IMPLND areas:															
EIA		60.30	71.77	38.02	82.24	38.02	15.11	38.02	15.11	166.21	75.9%	17.71	92.2%	9.15	11.3%
Basin total:		60.30	71.77	38.02	82.24	38.02	15.11	38.02	15.11	166.21	75.9%	17.71	92.2%	9.15	11.3%
Percent Impervious		3.7%	45.6%	0.0%	18.4%	0.0%	18.4%	0.0%	18.4%	75.9%	75.9%	17.71	92.2%	9.15	11.3%
NETWORK FACTORS															
PERLND 16 (TF)		0.945	0.321	0.510	0.961	0.510	0.961	0.510	0.961	3.344	126.09	0.115	16.32	8.12	1.03
PERLND 26 (TG)		0.738	0.408	0.001	1.562	0.001	1.562	0.001	1.562	3.344	126.09	0.115	16.32	8.12	1.03
PERLND 34 (OF)		1.935	1.024	0.375	1.203	0.375	1.203	0.375	1.203	3.344	126.09	0.115	16.32	8.12	1.03
PERLND 44 (OG)		0.510	0.467	1.728	1.778	1.728	1.778	1.728	1.778	3.344	126.09	0.115	16.32	8.12	1.03
PERLND 45 (FL)		-	-	-	-	-	-	-	-	-	-	-	-	-	-
PERLND 54 (SA)		0.712	1.036	0.554	0.089	0.554	0.089	0.554	0.089	3.344	126.09	0.115	16.32	8.12	1.03
IMPLND 14 (EIA)		0.185	2.728	-	1.259	-	1.259	-	1.259	10.507	75.9%	1.360	92.2%	0.043	0.086
SUM		5.025	5.981	3.168	6.853	3.168	6.853	3.168	6.853	13.851	75.9%	1.476	92.2%	0.762	11.3%

Table 4. Des Moines Creek Surface Water Subbasin Characteristics - 2. (STIA basins)

Land Use	Soil Type	% of total basin equal to EIA	Surface Water Subbasin Areas (Acres)													
			SDS-3		SDS-3A		SDS-4		SDS-5		SDS-6		SDS-7		SASA	
			Pervious	Effective	Pervious	Effective	Pervious	Effective	Pervious	Effective	Pervious	Effective	Pervious	Effective	Pervious	Effective
COMM	LAC	85%	-	-	-	-	-	-	-	-	-	-	-	-	-	-
	OGF	85%	-	-	-	-	-	-	-	-	-	-	-	-	-	-
	OGM	85%	-	-	-	-	-	-	-	-	-	-	-	-	-	-
	TGF	85%	-	-	-	-	-	-	-	-	-	-	-	-	-	-
F	TGM	85%	-	-	-	-	-	-	-	-	-	-	-	-	-	-
	LAC	0%	-	-	-	-	-	-	-	-	-	-	-	-	-	-
	OFF	0%	-	-	-	-	-	-	-	-	-	-	-	-	-	-
	OFM	0%	-	-	-	-	-	-	-	-	-	-	-	-	-	-
HD	TFF	0%	-	-	-	-	-	-	-	-	-	-	-	-	-	-
	TFM	0%	-	-	-	-	-	-	-	-	-	-	-	-	-	-
	TFS	0%	-	-	-	-	-	-	-	-	-	-	-	-	-	-
	LAC	30%	-	-	-	-	-	-	-	-	-	-	-	-	-	-
LD	TGF	30%	-	-	-	-	-	-	-	-	-	-	-	-	-	-
	TGM	30%	-	-	-	-	-	-	-	-	-	-	-	-	-	-
	LAC	13%	-	-	-	-	-	-	-	-	-	-	-	-	-	-
OG	OGF	13%	-	-	-	-	-	-	-	-	-	-	-	-	-	-
	OGM	13%	-	-	-	-	-	-	-	-	-	-	-	-	-	-
	OGS	13%	-	-	-	-	-	-	-	-	-	-	-	-	-	-
	TGF	13%	-	-	-	-	-	-	-	-	-	-	-	-	-	-
	TGM	13%	-	-	-	-	-	-	-	-	-	-	-	-	-	-
	LAC	0%	-	-	-	-	-	-	-	-	-	-	-	-	-	-
	OGF	0%	-	-	-	-	-	-	-	-	-	-	-	-	-	-
STIA	OGM	0%	-	-	-	-	-	-	-	-	-	-	-	-	-	-
	TGF	0%	-	-	-	-	-	-	-	-	-	-	-	-	-	-
	TGM	0%	-	-	-	-	-	-	-	-	-	-	-	-	-	-
	TGS	0%	-	-	-	-	-	-	-	-	-	-	-	-	-	-
	FLF	0%	-	-	-	-	-	-	-	-	-	-	-	-	-	-
	LAC	0%	-	-	-	-	-	-	-	-	-	-	-	-	-	-
	OGF	0%	-	-	-	-	-	-	-	-	-	-	-	-	-	-
	OGM	0%	-	-	-	-	-	-	-	-	-	-	-	-	-	-
	TGF	0%	-	-	-	-	-	-	-	-	-	-	-	-	-	-
	TGM	0%	-	-	-	-	-	-	-	-	-	-	-	-	-	-
TRANS	TGS	0%	-	-	-	-	-	-	-	-	-	-	-	-	-	-
	OGF	0%	-	-	-	-	-	-	-	-	-	-	-	-	-	-
	OGM	0%	-	-	-	-	-	-	-	-	-	-	-	-	-	-
TGF	0%	-	-	-	-	-	-	-	-	-	-	-	-	-	-	
			144.03	198.63	34.64	35.14	24.91	21.87	28.20	4.18	13.51	3.18	5.48	7.47	0.01	0.00
			0.28	0.54	-	-	0.40	2.53	-	-	-	-	3.93	0.69	0.00	0.00
			-	-	-	-	6.76	8.28	-	-	-	-	45.69	27.99	0.01	0.33
			-	-	-	-	-	-	-	-	-	-	-	-	0.00	21.41
			-	-	-	-	-	-	-	-	-	-	-	-	0.00	11.92
			-	-	-	-	-	-	-	-	-	-	-	-	-	0.58
			-	-	-	-	0.01	0.00	0.08	-	0.03	-	-	-	-	-

Table 1. Des Moines Creek Surface Water Subbasin Characteristics - 33 TIA basins)

Land Use	% of total basin equal to EIA	Surface Water Subbasin Areas (Acres)													
		SDS-3		SDS-3A		SDS-4		SDS-5		SDS-6		SDS-7		SASA	
Land Use Type		Pervious	Effective Impervious	Pervious	Effective Impervious	Pervious	Effective Impervious	Pervious	Effective Impervious	Pervious	Effective Impervious	Pervious	Effective Impervious	Pervious	Effective Impervious
Wetland	0%	-	-	-	-	-	-	-	-	-	-	-	-	-	-
Lake	-	-	-	-	-	-	-	-	-	-	-	-	-	-	-
Sasa-dp	-	-	-	-	-	-	-	-	-	-	-	-	-	-	-
Other	-	-	-	-	-	-	-	-	-	-	-	-	-	-	-
Basin total:		144.31	199.17	34.64	35.14	32.08	32.48	28.28	4.18	13.54	3.18	55.10	36.15	0.01	34.26
PERLND areas:															
(16) TF	-	-	-	-	-	-	-	-	-	-	-	-	-	-	-
(26) TG	144.31	144.31	-	34.64	6.77	28.28	-	-	-	13.54	-	45.89	-	-	0.01
(34) OF	-	-	-	-	-	-	-	-	-	-	-	-	-	-	-
(44) OG	-	-	-	-	25.31	-	-	-	-	-	-	3.93	-	-	-
(45) FL	-	-	-	-	-	-	-	-	-	-	-	5.48	-	-	-
(54) Wetland subtotal:	-	144.31	-	34.64	32.08	28.28	-	-	-	13.54	-	55.10	-	-	0.01
IMPLND areas:															
EIA	-	-	199.17	-	35.14	32.48	-	-	4.18	-	3.18	-	36.15	-	34.26
Basin total:		343.49	58.0%	69.78	50.4%	64.56	50.3%	32.46	12.9%	16.72	19.0%	91.25	39.6%	34.27	100.0%
Percent Impervious															
NETWORK FACTORS															
PERLND 16 (TF)	-	-	-	-	-	-	-	-	-	-	-	-	-	-	-
PERLND 26 (TG)	12.026	12.026	2.886	0.564	2.356	1.128	0.001	-	-	-	-	3.808	-	-	0.001
PERLND 34 (OF)	-	-	-	-	-	-	-	-	-	-	-	-	-	-	-
PERLND 44 (OG)	-	-	-	2.109	-	-	-	-	-	-	-	0.327	-	-	-
PERLND 45 (FL)	-	-	-	-	-	-	-	-	-	-	-	0.457	-	-	-
PERLND 54 (SA)	-	-	-	-	-	-	-	-	-	-	-	-	-	-	-
IMPLND 14 (EIA)	16.598	16.598	2.928	2.707	0.348	0.265	3.013	-	-	0.265	-	3.013	-	-	2.855
SUM	28.624	28.624	5.815	5.380	2.705	1.384	7.605	-	-	1.384	-	7.605	-	-	2.856

Table 1. Des Moines Creek Surface Water Subbasin Characteristics - 2L (STIA basins)

Land Use	Soil Type	% of total basin equal to EIA	Surface Water Subbasin Areas (Acres)												
			IWS NSPS		IWS PRIMARY		IWS SASA		Total		Percent of Total				
			Pervious	Effective Impervious	Pervious	Effective Impervious	Pervious	Effective Impervious	Pervious	Effective Impervious	Pervious	Effective Impervious			
COMM	LAC	85%	-	-	-	-	-	-	-	-	-	6.36	39.12	0.32%	1.97%
	OGF	85%	-	-	-	-	-	-	-	-	-	5.83	33.03	0.29%	1.66%
	OGM	85%	-	-	-	-	-	-	-	-	0.34	1.94	0.02%	0.10%	
	TGF	85%	-	-	-	-	-	-	-	-	12.06	70.87	0.61%	3.57%	
	TGM	85%	-	-	-	-	-	-	-	-	7.23	43.43	0.36%	2.19%	
F	LAC	0%	-	-	-	-	-	-	-	-	40.10	-	2.02%	0.00%	
	OFF	0%	-	-	-	-	-	-	-	-	45.13	-	2.27%	0.00%	
	OFM	0%	-	-	-	-	-	-	-	-	42.63	-	2.15%	0.00%	
	TFF	0%	-	-	-	-	-	-	-	-	16.41	-	0.83%	0.00%	
	TFM	0%	-	-	-	-	-	-	-	-	10.32	-	0.52%	0.00%	
	TFS	0%	-	-	-	-	-	-	-	-	0.24	-	0.01%	0.00%	
HD	LAC	30%	-	-	-	-	-	-	-	-	1.39	1.98	0.07%	0.10%	
	TGF	30%	-	-	-	-	-	-	-	-	10.69	14.26	0.54%	0.72%	
	TGM	30%	-	-	-	-	-	-	-	-	0.43	0.62	0.02%	0.03%	
LD	LAC	13%	-	-	-	-	-	-	-	-	10.80	2.84	0.55%	0.14%	
	OGF	13%	-	-	-	-	-	-	-	-	58.56	8.75	2.95%	0.44%	
	OGM	13%	-	-	-	-	-	-	-	-	43.72	6.53	2.20%	0.33%	
	OGS	13%	-	-	-	-	-	-	-	-	1.13	0.17	0.06%	0.01%	
	TGF	13%	-	-	-	-	-	-	-	-	58.18	23.35	2.93%	1.18%	
	TGM	13%	-	-	-	-	-	-	-	-	10.10	8.72	0.51%	0.44%	
OG	LAC	0%	-	-	-	-	-	-	-	-	0.03	-	0.00%	0.00%	
	OGF	0%	-	-	-	-	-	-	-	-	45.70	-	2.30%	0.00%	
	OGM	0%	-	-	-	-	-	-	-	-	6.79	-	0.34%	0.00%	
	TGF	0%	-	-	-	-	-	-	-	-	17.77	-	0.89%	0.00%	
	TGM	0%	-	-	-	-	-	-	-	-	8.88	-	0.45%	0.00%	
STIA	FLF	0%	-	-	-	-	-	-	-	-	5.48	7.47	0.28%	0.38%	
	LAC	0%	-	-	-	-	-	-	-	-	1.60	9.55	0.08%	0.48%	
	OGF	0%	-	-	-	-	-	-	-	-	39.59	34.02	1.99%	1.71%	
	OGM	0%	-	-	-	-	-	-	-	-	0.45	14.54	0.02%	0.73%	
	TGF	0%	0.31	13.44	6.52	259.31	1.75	321.33	692.03	16.18%	34.84%	0.20%	3.68%		
	TGM	0%	-	-	0.86	15.67	0.05	4.00	73.15	0.20%	3.68%	0.00%	0.44%		
	TGS	0%	-	-	-	-	-	-	8.72	0.00%	0.44%	0.00%	0.01%		
TRANS	OGF	0%	-	-	-	-	-	-	0.20	0.05%	0.01%	0.23	0.05%	0.01%	
	OGM	0%	-	-	-	-	-	-	0.00	0.00%	0.01%	0.29	0.00%	0.01%	
	TGF	0%	-	-	-	-	-	-	0.00	0.00%	0.01%	6.71	0.30%	0.34%	

Table 1. Des Moines Creek Surface Water Subbasin Characteristics -2L (TIA basins)

Land Use	Surface Water Subbasin Areas (Acres)								
	IWS NSPS		IWS PRIMARY		IWS SASA		Total		
	Pervious	Impervious	Pervious	Impervious	Pervious	Impervious	Pervious	Impervious	
Wetland	-	-	0.00	-	0.01	-	43.14	-	2.17%
Lake	-	-	6.65	-	-	-	14.45	-	0.73%
Sasa-dp	-	-	-	-	-	-	7.76	-	0.39%
Other	-	-	-	-	-	-	0.29	-	0.01%
Basin total:	0.31	13.44	13.53	289.08	0.11	58.32	883.50	1102.93	55.52%
PERLND areas:									
(16) TF	-	-	-	-	-	-	67.08	-	3.44%
(26) TG	0.31	-	7.38	-	0.05	-	476.99	-	24.44%
(34) OF	-	-	-	-	-	-	87.76	-	4.50%
(44) OG	-	-	6.15	-	0.04	-	203.05	-	10.40%
(45) FL	-	-	-	-	-	-	5.48	-	0.28%
(54) Wetland subtotal:	0.31	-	13.53	-	0.01	-	43.14	-	2.21%
IMPLND areas:									
EIA	-	13.44	-	269.08	-	58.32	-	1068.42	54.74%
Basin total:	13.75	13.44	302.62	269.08	58.42	58.32	1951.92	1068.42	100.00%
Percent Impervious	97.8%	97.8%	95.5%	99.8%	99.8%	99.8%	100.00%	100.00%	100.00%
NETWORK FACTORS									
PERLND 16 (TF)	-	-	-	-	-	-	5.590	-	3.44%
PERLND 26 (TG)	0.026	-	0.615	-	0.004	-	39.749	-	24.44%
PERLND 34 (OF)	-	-	-	-	-	-	7.313	-	4.50%
PERLND 44 (OG)	-	-	0.512	-	0.004	-	16.921	-	10.40%
PERLND 45 (FL)	-	-	-	-	-	-	0.457	-	0.28%
PERLND 54 (SA)	-	-	0.000	-	0.001	-	3.595	-	2.21%
IMPLND 14 (EIA)	1.120	-	24.090	-	4.860	-	89.035	-	54.74%
SUM	1.146	1.146	25.218	25.218	4.869	4.869	162.860	162.860	100.00%

Table 1. Des Moines Creek Contiguous Groundwater Subbasin Character. Des Moines Creek Contiguous Groundwater Subbasin Character (STIA basins)

Land Use	Soil Type	DM-10		DM-11		DM-12		DM-13		DM-4		DM-5		
		Effective Percolation	Effective Imperious	Effective Percolation	Effective Imperious	Effective Percolation	Effective Imperious	Effective Percolation	Effective Imperious	Effective Percolation	Effective Imperious	Effective Percolation	Effective Imperious	
PERLND areas:		11.34	3.85	6.13	11.53	43.54	3.49	2.08	8.85	4.89	0.01	18.74	7.06	5.91
(16) Till-Forest		8.85	12.28	4.50	14.44	20.88	22.10	0.88	23.22	5.61	0.16	0.96	-	0.88
(34) Outwash-Forest		6.12	12.43	6.51	0.30	43.70	0.06	1.35	8.55	39.06	10.62	11.18	-	0.96
(44) Outwash-Grass		58.08	32.71	38.02	82.20	103.95	50.64	20.92	58.08	40.02	20.92	46.6%	-	11.18
(54) Wetland		2.22	71.77	0.0%	15.10	18.4%	58.0%	9.74	2.22	79.0%	46.6%	-	-	-
IMPLND areas:		60.30	45.6%	38.02	82.20	103.95	50.64	20.92	60.30	40.02	20.92	46.6%	-	-
EIA		3.7%	45.6%	0.0%	18.4%	58.0%	79.0%	46.6%	3.7%	45.6%	79.0%	46.6%	-	-
Basin total:		60.30	45.6%	38.02	82.20	103.95	50.64	20.92	60.30	40.02	20.92	46.6%	-	-
Percent Imperious		3.7%	45.6%	0.0%	18.4%	58.0%	79.0%	46.6%	3.7%	45.6%	79.0%	46.6%	-	-
NETWORK FACTORS		0.945	0.321	0.510	0.961	3.628	0.291	0.173	0.945	0.321	0.510	0.961	0.291	0.173
PERLND 16	(TF)	0.738	0.408	0.001	1.561	0.375	0.589	0.493	0.738	0.408	0.001	1.561	0.589	0.493
PERLND 26	(TG)	1.935	1.024	1.740	1.203	1.842	-	0.074	1.935	1.024	1.740	1.203	-	0.074
PERLND 34	(OF)	0.510	0.467	0.543	0.025	0.013	0.005	0.080	0.510	0.467	0.543	0.025	0.005	0.080
PERLND 44	(OG)	0.712	1.036	-	1.259	5.021	3.335	0.112	0.712	1.036	-	1.259	3.335	0.112
PERLND 54	(SA)	0.185	2.726	3.168	6.850	8.662	4.220	0.812	0.185	2.726	3.168	6.850	4.220	0.812
IMPLND 14	(EIA)	5.025	5.981	3.168	6.850	8.662	4.220	1.743	5.025	5.981	3.168	6.850	4.220	1.743
SUM		5.025	5.981	3.168	6.850	8.662	4.220	1.743	5.025	5.981	3.168	6.850	4.220	1.743

1. Des Moines Creek Contiguous Groundwater Subbasin Characteritics - 1994 (STIA basins)

Land Use	Soil Type	% of total basin equal to EIA	DM-6		DM-7		DM-8		DM-9		SASA		SDE-4		SDS-1	
			Pervious	Effective Impervious	Pervious	Effective Impervious	Pervious	Effective Impervious	Pervious	Effective Impervious	Pervious	Effective Impervious	Pervious	Effective Impervious	Pervious	Effective Impervious
PERLND areas:			0.00	20.41	1.18	0.02	22.79	1.71	0.02	1.18	1.76	1.71	0.86	1.71	0.86	
(16)	Till-Forest		6.41	9.11	2.71	5.22	1.76	1.71	0.20	1.85	0.23	0.86	1.71	0.86		
(26)	Till-Grass		0.02	8.18	1.85	0.20	0.23	0.01	18.14	0.01	0.01	0.86	1.71	0.86		
(34)	Outwash-Forest		8.50	3.75	1.39	18.14	0.01	0.54	0.12	0.54	0.01	0.86	1.71	0.86		
(44)	Outwash-Grass		3.74	4.44	7.13	23.70	25.33									
(54)	Wetland		18.68	45.89												
IMPLND areas:																
EIA			0.09	17.73	17.04	3.49	8.94	1.71	8.94	9.71	9.08	9.94	9.08	9.08	9.08	9.08
Basin total:			18.77	63.62	24.17	27.19	34.27	11.41	26.1%	85.0%	91.3%	91.3%	91.3%	91.3%	91.3%	91.3%
Percent Impervious			0.5%	27.9%	70.5%	12.8%	26.1%	85.0%	26.1%	85.0%	91.3%	91.3%	91.3%	91.3%	91.3%	91.3%
NETWORK FACTORS																
PERLND 16	(TF)		0.000	1.701	0.098	0.002	1.899	0.142	0.002	0.098	0.072	0.142	0.072	0.072	0.072	0.072
PERLND 26	(TG)		0.534	0.759	0.226	0.435	0.146	0.146	0.435	0.146	0.072	0.146	0.072	0.072	0.072	0.072
PERLND 34	(OF)		0.002	0.681	0.154	0.016	0.019	0.019	0.016	0.001	0.019	0.001	0.019	0.001	0.019	0.019
PERLND 44	(OG)		0.709	0.313	0.116	1.512	0.001	0.001	1.512	0.045	0.045	0.045	0.045	0.045	0.045	0.045
PERLND 54	(SA)		0.312	0.370	1.420	0.010	0.045	0.045	0.010	0.745	0.745	0.745	0.745	0.745	0.745	0.745
IMPLND 14	(EIA)		0.008	1.478	2.014	0.291	0.745	0.745	0.291	0.809	0.809	0.809	0.809	0.809	0.809	0.809
SUM			1.564	5.302	2.014	2.266	2.856	0.851	2.266	0.851	0.828	0.828	0.828	0.828	0.828	0.828

Table 1. Des Moines Creek Contiguous Groundwater Subbasin Characteristics - 1994 (STIA basins)

Land Use	Soil Type	Groundwater Subbasin Areas (Acres)													
		SDS-2		SDS-3		SDS-4		SDS-5		SDS-6		IWS-PRIMARY		IWS-WEST	
		Pervious	Effective Impervious	Pervious	Effective Impervious	Pervious	Effective Impervious	Pervious	Effective Impervious	Pervious	Effective Impervious	Pervious	Effective Impervious	Pervious	Effective Impervious
PERLND areas:		2.76	3.46	0.00	10.54	1.77	10.54	0.00	10.54	1.77	1.38	2.67	1.09	6.14	9.90
(16)	Till-Forest	0.17	-	9.13	-	-	-	-	-	-	-	-	-	-	-
(26)	Till-Grass	4.06	-	0.14	-	-	-	-	-	-	-	-	-	-	-
(34)	Outwash-Forest	0.15	-	36.11	-	-	-	-	-	-	-	-	-	-	-
(44)	Outwash-Grass	0.52	-	0.00	-	-	-	-	-	-	-	-	-	-	-
(54)	Wetland	7.66	3.46	45.37	10.54	1.77	10.54	0.00	10.54	1.77	1.38	0.00	0.00	9.90	9.90
IMPLND areas:		1.49	2.60	19.19	0.35	11.18	0.02	11.18	0.02	11.18	0.02	0.02	0.02	0.02	0.02
	EIA	9.15	6.06	64.57	10.89	1.94	10.89	0.35	10.89	1.94	12.56	9.93	12.56	9.93	9.93
Basin total:		16.3%	42.9%	29.7%	3.2%	8.5%	89.0%	0.2%	89.0%	0.2%	89.0%	0.2%	89.0%	0.2%	0.2%
Percent Impervious		SDS-2	SDS-3	SDS-4	SDS-5	SDS-6	SDS-5	SDS-6	SDS-6	IWS-PRIMARY	IWS-PRIMARY	IWS-PRIMARY	IWS-PRIMARY	IWS-PRIMARY	IWS-PRIMARY
NETWORK FACTORS		0.230	0.288	0.000	0.878	0.148	0.878	0.000	0.878	0.148	0.115	0.222	0.115	0.222	0.115
PERLND 16	(TF)	0.014	-	0.761	-	-	-	-	-	-	-	-	-	-	-
PERLND 26	(TG)	0.398	-	0.011	-	-	-	-	-	-	-	-	-	-	-
PERLND 34	(OF)	0.012	-	3.009	-	-	-	-	-	-	-	-	-	-	-
PERLND 44	(OG)	0.043	-	0.000	-	-	-	-	-	-	-	-	-	-	-
PERLND 54	(SA)	0.124	0.216	1.599	0.029	0.014	0.029	0.000	0.029	0.014	0.931	0.000	0.931	0.000	0.000
IMPLND 14	(EIA)	0.762	0.505	5.380	0.907	0.161	0.907	0.002	0.907	0.161	1.046	0.002	1.046	0.002	0.002
SUM		0.762	0.505	5.380	0.907	0.161	0.907	0.002	0.907	0.161	1.046	0.002	1.046	0.002	0.002

Table 1. Des Moines Creek Contiguous Groundwater Subbasin Character ics - 1994 (STIA basins)

Land Use Type	Soil Type	% of total basin equal to EIA	IWS-SASA		MCS		TOTAL	
			Effective PerVIOUS	Impervious	Effective PerVIOUS	Impervious	Effective PerVIOUS	Impervious
PERLND areas:			36.57	10.04	-	0.07	123.63	52.90
(16) Till-Forest								
(26) Till-Grass								
(34) Outwash-Forest			0.24	3.63	-	-	77.23	127.80
(44) Outwash-Grass				1.35	-	-	41.47	523.02
(54) Wetland			51.92	6.57	0.07	0.07	790.71	267.69
IMPLND areas:			58.40	11.3%	0.07	0.0%	790.71	33.9%
EIA			IWS-SASA		MCS		TOTAL	
Basin total:			3.047	0.837	0.005	0.005	10.302	12.741
Percent Impervious			0.020	0.302	-	-	6.436	10.650
NETWORK FACTORS			0.113	0.548	-	-	3.455	22.308
PERLND 16 (TF)			4.866	0.005	0.005	0.005	65.893	65.893
PERLND 26 (TG)								
PERLND 34 (OF)								
PERLND 44 (OG)								
PERLND 54 (SA)								
IMPLND 14 (EIA)								
SUM								

Des Moines Creek Contiguous Groundwater Subbasin Characterization - 2006 (STIA basins)

Land Use	Soil Type	% of total basin equal to EIA	DM-10		DM-11		DM-12		DM-13		DM-3		DM-4		DM-5	
			Effective Permeability	Impermeability	Effective Permeability	Impermeability	Effective Permeability	Impermeability	Effective Permeability	Impermeability	Effective Permeability	Impermeability	Effective Permeability	Impermeability	Effective Permeability	Impermeability
PERLND areas:																
(16) TILL-Forest		11.34	3.85	6.13	11.53	3.43	6.13	11.53	3.43	6.13	11.53	3.43	6.13	11.53	3.43	6.13
(26) TILL-Grass		8.85	4.89	0.01	18.75	7.08	0.01	18.75	7.08	0.01	18.75	7.08	0.01	18.75	7.08	0.01
(34) Outwash-Forest		23.22	12.28	4.50	14.44	-	4.50	14.44	-	4.50	14.44	-	4.50	14.44	-	4.50
(44) Outwash-Grass		6.12	5.81	20.73	21.33	-	20.73	21.33	-	20.73	21.33	-	20.73	21.33	-	20.73
(45) Fill		-	-	-	-	-	-	-	-	-	-	-	-	-	-	-
(54) Wetland		8.55	12.43	6.65	1.07	0.06	6.65	1.07	0.06	6.65	1.07	0.06	6.65	1.07	0.06	6.65
subtotal:		58.08	39.06	38.02	67.12	10.57	38.02	67.12	10.57	38.02	67.12	10.57	38.02	67.12	10.57	38.02
IMPLND areas:																
EIA		2.22	32.71	15.10	40.20	9.59	32.71	15.10	40.20	9.59	32.71	15.10	40.20	9.59	32.71	15.10
Basin total:		60.30	71.77	38.02	82.23	50.77	71.77	38.02	82.23	50.77	71.77	38.02	82.23	50.77	71.77	38.02
Percent Impermeous		3.7%	45.6%	0.0%	18.4%	55.9%	3.7%	45.6%	0.0%	18.4%	55.9%	3.7%	45.6%	0.0%	18.4%	55.9%
NETWORK FACTORS																
PERLND 16 (TF)		0.945	0.321	0.510	0.961	0.286	0.510	0.961	0.286	0.510	0.961	0.286	0.510	0.961	0.286	0.510
PERLND 28 (TG)		0.738	0.408	0.001	1.562	0.590	0.001	1.562	0.590	0.001	1.562	0.590	0.001	1.562	0.590	0.001
PERLND 34 (OF)		1.935	1.024	0.375	1.203	-	0.375	1.203	-	0.375	1.203	-	0.375	1.203	-	0.375
PERLND 44 (OG)		0.510	0.467	1.728	1.778	-	1.728	1.778	-	1.728	1.778	-	1.728	1.778	-	1.728
PERLND 45 (FL)		-	-	-	-	-	-	-	-	-	-	-	-	-	-	-
PERLND 54 (SA)		0.712	1.036	0.554	0.089	0.005	0.554	0.089	0.005	0.554	0.089	0.005	0.554	0.089	0.005	0.554
IMPLND 14 (EIA)		0.185	2.726	-	1.258	4.499	-	1.258	4.499	-	1.258	4.499	-	1.258	4.499	-
SUM		5.025	5.981	3.168	6.852	8.042	3.168	6.852	8.042	3.168	6.852	8.042	3.168	6.852	8.042	3.168

Table 1 - Des Moines Creek Contiguous Groundwater Subbasin Charac ilcs - 2008 (STIA basins)

Land Use	Soil Type	% of total basin equal to EIA	DM-6		DM-7		DM-8		DM-9		SASA		SDE-4		SDS-1	
			Effective Pervious	Effective Impervious	Effective Pervious	Effective Impervious	Effective Pervious	Effective Impervious	Effective Pervious	Effective Impervious	Effective Pervious	Effective Impervious	Effective Pervious	Effective Impervious	Effective Pervious	Effective Impervious
PERLND areas:																
(16)	Till-Forest		6.41	20.41	1.18	0.02	1.18	0.02	0.02	0.01	1.65	1.39	1.65	1.39	1.65	1.39
(26)	Till-Grass		0.02	9.11	2.71	5.22	2.71	5.22	0.20	-	-	-	-	-	-	-
(34)	Outwash-Forest		8.50	8.18	1.85	0.20	1.85	0.20	18.14	-	-	-	-	-	-	-
(44)	Outwash-Grass			3.76												
(45)	Fill															
(54)	Weiland		3.74	4.44	1.39	0.12	1.39	0.12	23.71	0.01	1.65	1.39	1.65	1.39	1.65	1.39
IMPLND areas:																
EIA																
Basin total:			18.75	63.66	24.17	27.20	24.17	27.20	34.27	34.27	11.39	11.39	11.39	11.39	11.39	11.39
Percent impervious			0.4%	27.9%	70.5%	12.8%	70.5%	12.8%	100.0%	85.5%	85.5%	85.5%	85.5%	85.5%	85.5%	85.5%
NETWORK FACTORS																
PERLND 16	(TF)		0.534	1.701	0.098	0.002	0.098	0.002	0.001	0.137	0.115	0.137	0.115	0.137	0.115	0.137
PERLND 26	(TG)		0.002	0.759	0.226	0.435	0.226	0.435	-	-	-	-	-	-	-	-
PERLND 34	(OF)		0.709	0.681	0.154	0.017	0.154	0.017	-	-	-	-	-	-	-	-
PERLND 44	(OG)			0.313		1.512		1.512	-	-	-	-	-	-	-	-
PERLND 45	(FL)								-	-	-	-	-	-	-	-
PERLND 54	(SA)		0.312	0.370	0.116	0.010	0.116	0.010	2.855	0.811	0.710	0.811	0.710	0.811	0.710	0.811
IMPLND 14	(EIA)		0.007	1.480	1.420	0.291	1.420	0.291	2.856	0.949	0.825	0.949	0.825	0.949	0.825	0.949
SUM			1.563	5.305	2.014	2.267	2.014	2.267	2.856	0.949	0.825	0.949	0.825	0.949	0.825	0.949

Table 1. Des Moines Creek Contiguous Groundwater Subbasin Characteristics - 2006 (STIA basins)

Land Use	Soil Type	% of total basin equal to EIA	Groundwater Subbasin Areas (Acres)						
			SDS-2	SDS-3	SDS-4	SDS-5	SDS-6	PRIMARY	
			Effective Pervious	Effective Pervious	Effective Pervious	Effective Pervious	Effective Pervious	Effective Pervious	Effective Pervious
			Impervious	Impervious	Impervious	Impervious	Impervious	Impervious	Impervious
PERLND areas:									
(16) Till-Forest			2.99	2.95	6.77	9.56	1.62	4.71	0.05
(26) Till-Grass			-	-	-	-	-	-	-
(34) Outwash-Forest			4.61	-	25.31	-	-	6.14	0.04
(44) Outwash-Grass			-	-	-	-	-	-	-
(45) Fill			-	-	-	-	-	-	-
(54) Wetland			0.52	-	-	-	-	0.00	0.01
subtotal:			8.12	2.95	32.08	9.56	1.62	10.86	0.11
IMPLND areas:									
EIA		1.03	-	-	32.48	1.33	-	-	-
Basin total:			9.15	6.07	64.56	10.89	1.94	22.48	58.42
Percent impervious		11.3%	51.4%	50.3%	12.2%	16.4%	51.7%	99.8%	
NETWORK FACTORS									
PERLND 16 (TF)			0.249	0.246	0.564	0.798	0.135	0.393	0.004
PERLND 26 (TG)			-	-	-	-	-	-	-
PERLND 34 (OF)			0.384	-	2.109	-	-	0.512	0.004
PERLND 44 (OG)			-	-	-	-	-	-	-
PERLND 45 (FL)			0.043	-	-	-	-	0.000	0.001
PERLND 54 (SA)			0.088	0.260	2.707	0.111	0.026	0.969	4.860
IMPLND 14 (EIA)			0.762	0.506	5.380	0.907	0.161	1.874	4.869
SUM									

Table 1. Des Moines Creek Contiguous Groundwater Subbasin Characterization Data - 2006 (STIA basins)

Land Use Type	Soil equal to EIA	% of total basin	Total Groundwater Subbasin Areas (Acres)	
			MC9	TOTAL
			Effective Permeability	Effective Permeability
PERLND areas:				
(16) Till-Forest	-		58.77	
(26) Till-Grass	0.07		141.63	
(34) Outwash-Forest	-		56.44	
(44) Outwash-Grass	-		128.07	
(45) Fill	-			
(54) Wetland	-		40.41	
subtotal:	0.07		430.22	
IMPLND areas:				
EIA				352.91
Basin total:	0.07		783.13	
Percent impervious				45.1%
			TOTAL	
NETWORK FACTORS				
PERLND 16 (TF)	-		4,898	
PERLND 26 (TG)	0.005		11,794	
PERLND 34 (OF)	-		5,537	
PERLND 44 (OG)	-		10,256	
PERLND 45 (FL)	-			
PERLND 54 (SA)	-		3,388	
IMPLND 14 (EIA)	-		29,409	
SUM	0.005		65,280	

Table 1. Des Moines Non-Contiguous Groundwater Subbasin Characterization - 1994 (STIA basins)

Land Use Type	Soil Type	Groundwater Subbasin Areas (Acres)			
		D13	D3	D4	TOTAL
		Effective Permeable	Effective Permeable	Effective Permeable	Effective Permeable
		Impermeable	Impermeable	Impermeable	Impermeable
PERLND areas:					
(16) Till-Forest		-	-	-	-
(26) Till-Grass		0.00	0.20	0.01	0.21
(34) Outwash-Forest		-	-	-	-
(44) Outwash-Grass		-	-	-	-
(54) Wetland		-	-	-	-
IMPLND areas:					
subtotal:		0.00	0.20	0.01	0.21
EIA					
Basin total:		0.01	0.26	0.06	0.33
Percent impermeable		85.0%	23.2%	85.0%	36.9%
NETWORK FACTORS		D13	D3	D4	TOTAL
PERLND 16 (TF)		-	-	-	-
PERLND 26 (TG)		0.000	0.016	0.001	0.017
PERLND 34 (OF)		-	-	-	-
PERLND 44 (OG)		-	-	-	-
PERLND 54 (SA)		-	-	-	-
IMPLND 14 (EIA)		0.001	0.005	0.004	0.010
SUM		0.001	0.021	0.005	0.027

Des Moines Non-Contiguous Groundwater Subbasin Characterization - 2006 (STIA basins)

Land Use	Soil Type	% of total basin equal to EIA	Groundwater Subbasin Areas (Acres)							
			D13		D3		D4		TOTAL	
			Pervious	Effective Impervious	Pervious	Effective Impervious	Pervious	Effective Impervious	Pervious	Effective Impervious
PERLND areas:										
(16)	Till-Forest		0.00	0.20	0.02	0.20	0.02	0.21	0.02	0.21
(26)	Till-Grass		-	-	-	-	-	-	-	-
(34)	Outwash-Forest		-	-	-	-	-	-	-	-
(44)	Outwash-Grass		-	-	-	-	-	-	-	-
(45)	Fill		-	-	-	-	-	-	-	-
(54)	Wetland		0.00	0.20	0.02	0.20	0.02	0.21	0.02	0.21
IMPLND areas:										
	EIA		0.01	0.01	0.01	0.05	0.09	0.15	0.09	0.15
Basin total:			0.01	0.25	0.10	0.05	0.09	0.36	0.10	0.15
Percent Impervious			85.0%		20.9%		85.0%		40.9%	
NETWORK FACTORS			D13		D3		D4		TOTAL	
PERLND 16	(TF)		0.000	0.016	0.001	0.016	0.001	0.018	0.001	0.018
PERLND 26	(TG)		-	-	-	-	-	-	-	-
PERLND 34	(OF)		-	-	-	-	-	-	-	-
PERLND 44	(OG)		-	-	-	-	-	-	-	-
PERLND 45	(FL)		-	-	-	-	-	-	-	-
PERLND 54	(SA)		0.001	0.004	0.007	0.004	0.007	0.012	0.007	0.012
IMPLND 14	(EIA)		0.001	0.021	0.008	0.021	0.008	0.030	0.008	0.030
SUM			0.001	0.021	0.008	0.021	0.008	0.030	0.008	0.030

```

RUN
GLOBAL
*** SEATAC AIRPORT HSPF BASIN MODEL OF MILLER CREEK
*** FILE: MC23inif.INP - 2006 future condition
*** USED FOR LOW FLOW. 12/06/01 BY ATC JTB
*** MADE The following changes to input file to deal with fill inflow: ***
*** Combined infiltration from sdw1a and sdw1b ponds into one file
*** BASED ON MILL65.INP FILE FROM AQUA TERRA
*** Mlowflow.WDM:
*** REMOVED FILL AREAS FOR PGG CUT OUT AREA
*** USING FULL LENGTH OF RECORD TO SET STATE VARIABLES
*** END CHANGES ***
*** ADDED PERLND 47,57,
*** ADDED GROUND WATER INFILTRATION TO WDM FOR USE WITH MCAGWO.INP
*** FK revised SDW1A and SDW1B with flow splitters, storages at SDN3/3X,
SDN2X/4X;
*** FK revised MC-1 and SDN-2X land uses, added POC at Lake Reba, removed
run-of-river tables
*** FK added POC downstream of facilities SDW1A and SDW1B
MILLER CREEK BASIN HSPF MODEL
*** START 1994 1 1 0 0 END 1996 8 30 24 0
START 1990 10 1 0 0 END 1994 9 30 24 0
RUN INTERP OUTPUT LEVEL 3
RESUME 0 RUN 1
END GLOBAL

```

```

FILES
<type> <fun>***<-----fname----->
MESSU 24 d:\PARA\SEATAC\MILLER\LOWFLOW\MLOWFLO4.MES
WDM 25 d:\PARA\SEATAC\MILLER\LOWFLOW\MLOWFLOW.WDM
61 d:\PARA\SEATAC\MILLER\LOWFLOW\PER.L61
62 d:\PARA\SEATAC\MILLER\LOWFLOW\RCH.L62

```

END FILES

```

OPN SEQUENCE
INGRP INDELT 01:00
PERLND 16
PERLND 26
PERLND 34
PERLND 44
PERLND 45
PERLND 54
***SPECIAL PERLND FOR INFLOW OF GROUNDWATER FROM PGG
PERLND 80
IMPLND 14
RCHRES 1
RCHRES 23
RCHRES 24
RCHRES 2
RCHRES 3
RCHRES 33
RCHRES 4
RCHRES 5
RCHRES 50
RCHRES 242
RCHRES 240
COPY 61
COPY 44
RCHRES 51
RCHRES 43
RCHRES 451
RCHRES 452
COPY 45

```

COPY 645
 RCHRES 46
 RCHRES 552
 RCHRES 52
 RCHRES 53
 COPY 53
 RCHRES 54
 RCHRES 37
 RCHRES 237
 COPY 37
 RCHRES 147
 RCHRES 247
 COPY 66
 COPY 69
 RCHRES 47

***PERLND FOR INFILTRATION POND 47 OUTLET

PERLND 47
 COPY 62
 COPY 63
 COPY 67
 COPY 68

*** --> output SDW1A infiltration discharge to WDM dataset 5 in in/ac <--

COPY 47
 COPY 70
 RCHRES 34
 RCHRES 135
 RCHRES 570
 RCHRES 57
 RCHRES 257

*** PERLND FOR INFILTRATION POND 57 OUTLET

PERLND 57
 COPY 64
 COPY 65
 COPY 357
 COPY 56
 COPY 57
 COPY 71
 RCHRES 35
 COPY 55
 RCHRES 10
 RCHRES 16
 RCHRES 11
 RCHRES 13
 RCHRES 12
 RCHRES 15
 RCHRES 14
 RCHRES 17

END INGRP
 END OPN SEQUENCE

PERLND

GEN-INFO

<PLS >

-

Name

NBLKS

Unit-systems

Printer

User t-series Engl Metr

in out

16	TFM- TILL FOR MOD	1	1	1	1	61	0
26	TGM- TILL GR MOD	1	1	1	1	61	0
34	OF - OUTWASH FOR	1	1	1	1	61	0
44	OG - OUTWASH GR	1	1	1	1	61	0

***PERLND FOR NEW AIRPORT FILL; NONE IN CALIBRATION

45	AIRPORT FILL	1	1	1	1	61	0
47	OG - INFILTRATION 1	1	1	1	1	61	0
54	SA - WETLANDS	1	1	1	1	61	0

57 OG - INFILTRATION 3 1 1 1 1 61 0
 80 LOW FLOW 1 1 1 1 61 0

END GEN-INFO

ACTIVITY

<PLS > ***** Active Sections *****
 # - # ATMP SNOW PWAT SED PST PWG PQAL MSTL PEST NITR PHOS TRAC ***
 14 200 0 0 1 0 0 0 0 0 0 0 0 0

END ACTIVITY

PRINT-INFO

<PLS > ***** Print-flags ***** PIVL PYR
 # - # ATMP SNOW PWAT SED PST PWG PQAL MSTL PEST NITR PHOS TRAC *****
 14 200 0 0 5 0 0 0 0 0 0 0 0 0 1 9

END PRINT-INFO

PWAT-PARM1

<PLS > ***** Flags *****
 # - # CSNO RTOP UZFG VCS VUZ VNN VIFW VIRC VLE ***
 14 200 0 0 0 0 0 0 0 0 0

END PWAT-PARM1

PWAT-PARM2

<PLS > ***
 # - # ***FOREST LZSN INFILT LSUR SLSUR KVARV AGWRC
 16 9.0000 0.3200 400.00 0.1000 0.5000 0.9960
 26 9.0000 0.1200 400.00 0.1000 0.5000 0.9960
 34 10.0000 2.0000 400.00 0.0500 0.3000 0.9960
 44 10.0000 0.8000 400.00 0.0500 0.3000 0.9960
 45 7.5000 0.0200 300.00 0.0700 0.0000 0.9960
 47 10.0000 0.8000 400.00 0.0500 0.3000 0.9960
 54 8.0000 2.0000 100.00 0.0010 0.5000 0.9960
 57 10.0000 0.8000 400.00 0.0500 0.3000 0.9960
 80 9.0000 0.1200 400.00 0.1000 0.5000 0.9960

END PWAT-PARM2

PWAT-PARM3

<PLS > ***
 # - # *** PETMAX PETMIN INFEXP INFILD DEEPFR BASETP AGWETP
 16 2.0000 2.0000 0.33 0.00 0.0
 26 2.0000 2.0000 0.33 0. 0.
 34 2.0000 2.0000 0.33 0.00 0.0
 44 2.0000 2.0000 0.33 0. 0.
 47 2.0000 2.0000 0.33 0. 0.
 45 2.0000 2.0000 0.33 0. 0.
 54 10.000 2.0000 0.33 0. 0.7
 57 2.0000 2.0000 0.33 0. 0.
 80 2.0000 2.0000 0.33 0. 0.

END PWAT-PARM3

PWAT-PARM4

<PLS > *****
 # - # CEPSC UZSN NSUR INTFW IRC LZETP***
 16 0.2000 0.7500 0.3500 9.000 0.7000 0.7000
 26 0.1000 0.3750 0.2500 9.000 0.7000 0.2500
 34 0.2000 0.7500 0.3500 0.000 0.7000 0.7000
 44 0.1000 0.7500 0.2500 0.000 0.7000 0.2500
 47 0.1000 0.7500 0.2500 0.000 0.7000 0.2500
 45 0.1000 0.2800 0.2500 6.000 0.1500 0.6000
 54 0.1000 2.2500 0.5000 1.000 0.7000 0.8000
 57 0.1000 0.7500 0.2500 0.000 0.7000 0.2500
 80 0.1000 0.3750 0.2500 9.000 0.7000 0.2500

END PWAT-PARM4

PWAT-STATE1

<PLS > PWATER state variables***
 # - #**** CEPS SURS UZS IFWS LZS AGWS GWVS
 16 0.000 0. 0.0010 0.00 0.941 3.108 0.048
 26 0.000 0. 0.0010 0.00 7.672 3.341 0.071
 34 0.000 0. 0.0010 0.00 1.187 3.776 0.052

44	0.000	0.	0.0040	0.00	9.402	4.905	0.104
45	0.000	0.	0.0000	0.00	2.000	2.000	0.000
54	0.000	0.	0.0960	0.00	3.211	0.000	0.000
47	0.000	0.	0.0000	0.00	2.000	2.000	0.000
57	0.000	0.	0.0000	0.00	2.000	2.000	0.000
80	0.000	0.	0.0000	0.00	7.672	3.341	0.071

END PWAT-STATE1
END PERLND

IMPLND

GEN-INFO

```
<ILS >      Name      Unit-systems  Printer
# - #      User  t-series Engl Metr
              in  out
14  IMPERVIOUS      1  1  1  60  0
```

END GEN-INFO

ACTIVITY

```
<ILS > ***** Active Sections ****
# - # ATMP SNOW IWAT SLD IWG IQAL ***
14  0  0  1  0  0  0
```

END ACTIVITY

PRINT-INFO

```
<ILS > ***** Print-flags ***** PIVL  PYR
# - # ATMP SNOW IWAT SLD IWG IQAL *****
14  0  0  6  0  0  0  1  9
```

END PRINT-INFO

IWAT-PARM1

```
<ILS >      Flags      ***
# - # CSNO RTOP  VRS  VNN  RTLI  ***
14  0  0  0  0  0
```

END IWAT-PARM1

IWAT-PARM2

```
<ILS >      ***
# - #      LSUR      SLSUR      NSUR      RETSC      ***
14  100.00  0.0100  0.1000  0.1000
```

END IWAT-PARM2

IWAT-PARM3

```
<ILS >      ***
# - #      PETMAX  PETMIN      ***
14
```

END IWAT-PARM3

IWAT-STATE1

```
<ILS > IWATER state variables  ***
# - #      RETS      SURS      ***
14  1.0000E-3  1.0000E-3
```

END IWAT-STATE1

END IMPLND

EXT SOURCES

*** NOTE: The only RCHRES that precip and PET are applied to are lakes and ponds
*** FOLLOWING RCHRES ARE PONDS: 57, 247, 237

```
<-Volume-> <Member> Ssysgap<--Mult-->Tran <-Target vols> <-Grp> <-Member-> ***
<Name> # <Name> # tem strg<-factor->strg <Name> # # <Name> # # ***
*** PRECIP/EVAP TO PERVIOUS/IMPERV SURFACES
WDM 1002 PREC ENGLZERO 1.00 PERLND 14 46 EXTNL PREC
WDM 1002 PREC ENGLZERO 0.00 PERLND 47 EXTNL PREC
WDM 1002 PREC ENGLZERO 0.00 PERLND 57 EXTNL PREC
WDM 1002 PREC ENGLZERO 1.00 PERLND 48 56 EXTNL PREC
WDM 1002 PREC ENGLZERO 1.00 PERLND 58 79 EXTNL PREC
WDM 1002 PREC ENGLZERO 1.00 PERLND 80 EXTNL PREC
WDM 1002 PREC ENGLZERO 1.00 IMPLND 14 EXTNL PREC
```

File Mlowflo4.inp, Printed Monday, December 10, 2001

```

WDM      1  EVAP  ENGLZERO  0.8  PERLND  14  46  EXTNL  PETINP
WDM      1  EVAP  ENGLZERO  0.0  PERLND  47          EXTNL  PETINP
WDM      1  EVAP  ENGLZERO  0.0  PERLND  57          EXTNL  PETINP
WDM      1  EVAP  ENGLZERO  0.8  PERLND  48  56  EXTNL  PETINP
WDM      1  EVAP  ENGLZERO  0.8  PERLND  58  79  EXTNL  PETINP
WDM      1  EVAP  ENGLZERO  0.8  PERLND  80          EXTNL  PETINP
WDM      1  EVAP  ENGLZERO  0.8  IMPLND  14          EXTNL  PETINP
*** PRECIP/EVAP TO LAKES
WDM      1002  PREC  ENGLZERO          RCHRES  1  EXTNL  PREC
WDM      1  EVAP  ENGLZERO  0.8  RCHRES  1  EXTNL  POTEV
WDM      1002  PREC  ENGLZERO          RCHRES  4  EXTNL  PREC
WDM      1  EVAP  ENGLZERO  0.8  RCHRES  4  EXTNL  POTEV
WDM      1002  PREC  ENGLZERO          RCHRES  11  EXTNL  PREC
WDM      1  EVAP  ENGLZERO  0.8  RCHRES  11  EXTNL  POTEV
WDM      1002  PREC  ENGLZERO          RCHRES  13  EXTNL  PREC
WDM      1  EVAP  ENGLZERO  0.8  RCHRES  13  EXTNL  POTEV
WDM      1002  PREC  ENGLZERO          RCHRES  23  EXTNL  PREC
WDM      1  EVAP  ENGLZERO  0.8  RCHRES  23  EXTNL  POTEV
WDM      1002  PREC  ENGLZERO          RCHRES  34  EXTNL  PREC
WDM      1  EVAP  ENGLZERO  0.8  RCHRES  34  EXTNL  POTEV
WDM      1002  PREC  ENGLZERO          RCHRES  53  EXTNL  PREC
WDM      1  EVAP  ENGLZERO  0.8  RCHRES  53  EXTNL  POTEV
WDM      1002  PREC  ENGLZERO          RCHRES  54  EXTNL  PREC
WDM      1  EVAP  ENGLZERO  0.8  RCHRES  54  EXTNL  POTEV
WDM      1002  PREC  ENGLZERO          RCHRES  237  EXTNL  PREC
WDM      1  EVAP  ENGLZERO  0.8  RCHRES  237  EXTNL  POTEV
WDM      1002  PREC  ENGLZERO          RCHRES  247  EXTNL  PREC
WDM      1  EVAP  ENGLZERO  0.8  RCHRES  247  EXTNL  POTEV
WDM      1002  PREC  ENGLZERO          RCHRES  57  EXTNL  PREC
WDM      1  EVAP  ENGLZERO  0.8  RCHRES  57  EXTNL  POTEV

```

```

*** Fill flow directly to stream:
*** Conversion factor from cu. ft./day to acre-ft/interval
*** divide by 43560*24
WDM      7000  FLOW  ENGL  .000000957SAME RCHRES  35  INFLOW IVOL
*** till seepage groundwater flow from Fill area.  PGG time series
*** Conversion factor from cu. ft./day to inches
*** (1/(43560*24) * 12)/area  (114.81ac)
*** finally convert for deepfr of .33 by multiplying by .67
WDM      7001  FLOW  ENGLZERO.000000067SAME PERLND  80  EXTNL  AGWLI
*** surface runoff to infiltration facilities
*** Conversion factor from cu. ft./hr to acre-ft/interval
*** divide by 43560*24
*** converted for contributing area ratios.
*** 22.35 ac
WDM      7002  FLOW  ENGL  .000004561SAME RCHRES  237  INFLOW IVOL
*** 31.22 ac
WDM      7002  FLOW  ENGL  .000006371SAME RCHRES  47  INFLOW IVOL
*** 58.93 ac
WDM      7002  FLOW  ENGL  .000012025SAME RCHRES  257  INFLOW IVOL

```

END EXT SOURCES

EXT TARGETS

```

<-Volume-> <-Grp> <-Member-><--Mult-->Tran <-Volume-> <Member> Tsys Tgap Amd ***
<Name> # <Name> # <-factor->strg <Name> # <Name> tem strg strg***

```

***PROJECT CONDITION FLOWS

*** RCHRES=LOCATION:

```

*** 54=MCDF 47=SDW1A INFILTRATION TANK 43=SDN3X 247=SDW1A POND G
*** 17=MOUTH 49=SDW2 44=SDN4X 52=SDN1 451= EXISTING NEPL
*** 61=SDN2X 57=SDW1B 51=SDN2X+SDN4X 53=Lake Reba 452=NEW NEPL
*** 45=NEPL POC 55=SR509 39=SDN3A/SDW1A POC
*** 46=CARGO 37=SDN3AI VAULT 237=SDN3AO POND
*** GAUGE POINTS (17=MOUTH, 54=MILLER RDF, 55=SR509)

```

Code	Flow Type	Location	Flow ID	Flow Name	Flow Value	Flow Unit	Flow Direction	Flow Status	Flow Type
RCHRES 35	HYDR	RO	1 1	WDM 7036	FLOW		ENGL		REPL
***RCHRES 17	HYDR	RO	1 1	WDM 113	FLOW		ENGL		REPL
***COPY 55	OUTPUT MEAN		1 1 12.1	WDM 118	FLOW		ENGL		REPL
***RCHRES 54	HYDR	RO	1 1	WDM 114	FLOW		ENGL		REPL
*** DETENTION POND FLOWS									
***COPY 61	OUTPUT MEAN		1 1 12.1	WDM 101	FLOW		ENGL		REPL
***RCHRES 552	HYDR	RO	1 1	WDM 102	FLOW		ENGL		REPL
***RCHRES 451	HYDR	RO	1 1	WDM 105	FLOW		ENGL		REPL
***RCHRES 452	HYDR	RO	1 1	WDM 119	FLOW		ENGL		REPL
***RCHRES 46	HYDR	RO	1 1	WDM 106	FLOW		ENGL		REPL
***** write SDW1A Inf.Tank # 1 outlets to WDM 107 and 108 like so:									
***COPY 62	OUTPUT MEAN		1 1 12.1	WDM 107	FLOW		ENGL		REPL
***COPY 63	OUTPUT MEAN		1 1 12.1	WDM 108	FLOW		ENGL		REPL
***** write SDW1A det. pond G outlets to WDM files:									
***COPY 66	OUTPUT MEAN		1 1 12.1	WDM 112	FLOW		ENGL		REPL
***COPY 69	OUTPUT MEAN		1 1 12.1	WDM 1120	FLOW		ENGL		REPL
***** write SDW1A det. vault G1 to WDM files:									
***COPY 67	OUTPUT MEAN		1 1 12.1	WDM 109	FLOW		ENGL		REPL
***COPY 68	OUTPUT MEAN		1 1 12.1	WDM 1090	FLOW		ENGL		REPL
***** write flow splitter outlets to WDM files:									
***RCHRES 570	HYDR	RO	1 1	WDM 210	FLOW		ENGL		REPL
***COPY 64	OUTPUT MEAN		1 1 12.1	WDM 110	FLOW		ENGL		REPL
***COPY 65	OUTPUT MEAN		1 1 12.1	WDM 115	FLOW		ENGL		REPL
***** write SDW1B inf. tank outlets to WDM files:									
***COPY 56	OUTPUT MEAN		1 1 12.1	WDM 121	FLOW		ENGL		REPL
***COPY 57	OUTPUT MEAN		1 1 12.1	WDM 120	FLOW		ENGL		REPL
***** write SDW1B pond D outlet to WDM file:									
***COPY 357	OUTPUT MEAN		1 1 12.1	WDM 211	FLOW		ENGL		REPL
***** write SDN3A vaults to WDM files:									
***RCHRES 37	HYDR	RO	1 1	WDM 111	FLOW		ENGL		REPL
***RCHRES 237	HYDR	RO	1 1	WDM 122	FLOW		ENGL		REPL
***** write SDN3/3x, SDN4/4x, and SDN4x/2x vaults to WDM files:									
***RCHRES 43	HYDR	RO	1 1	WDM 103	FLOW		ENGL		REPL
***COPY 44	OUTPUT MEAN		1 1 12.1	WDM 104	FLOW		ENGL		REPL
***RCHRES 51	HYDR	RO	1 1	WDM 139	FLOW		ENGL		REPL
***** DETENTION STAGES									
***RCHRES 47	HYDR	STAGE		WDM 652	STAG		ENGL		REPL
***RCHRES 147	HYDR	STAGE		WDM 657	STAG		ENGL		REPL
***RCHRES 247	HYDR	STAGE		WDM 654	STAG		ENGL		REPL
***RCHRES 552	HYDR	STAGE		WDM 601	STAG		ENGL		REPL
***RCHRES 57	HYDR	STAGE		WDM 651	STAG		ENGL		REPL
***RCHRES 257	HYDR	STAGE		WDM 655	STAG		ENGL		REPL
***RCHRES 237	HYDR	STAGE		WDM 656	STAG		ENGL		REPL
***RCHRES 37	HYDR	STAGE		WDM 650	STAG		ENGL		REPL
***RCHRES 54	HYDR	STAGE		WDM 61	STAG		ENGL		REPL
***RCHRES 451	HYDR	STAGE		WDM 662	STAG		ENGL		REPL
***RCHRES 452	HYDR	STAGE		WDM 667	STAG		ENGL		REPL
***RCHRES 46	HYDR	STAGE		WDM 663	STAG		ENGL		REPL
***RCHRES 43	HYDR	STAGE		WDM 664	STAG		ENGL		REPL
***RCHRES 44	HYDR	STAGE		WDM 665	STAG		ENGL		REPL
***RCHRES 51	HYDR	STAGE		WDM 666	STAG		ENGL		REPL
*** DETENTION VOLUMES									
***RCHRES 47	HYDR	VOL		WDM 752	VOL		ENGL		REPL
***RCHRES 147	HYDR	VOL		WDM 757	VOL		ENGL		REPL
***RCHRES 247	HYDR	VOL		WDM 754	VOL		ENGL		REPL
***RCHRES 552	HYDR	VOL		WDM 602	VOL		ENGL		REPL
***RCHRES 57	HYDR	VOL		WDM 751	VOL		ENGL		REPL
***RCHRES 257	HYDR	VOL		WDM 755	VOL		ENGL		REPL
***RCHRES 237	HYDR	VOL		WDM 756	VOL		ENGL		REPL
***RCHRES 37	HYDR	VOL		WDM 750	VOL		ENGL		REPL
***RCHRES 54	HYDR	VOL		WDM 62	VOL		ENGL		REPL
***RCHRES 451	HYDR	VOL		WDM 762	VOL		ENGL		REPL
***RCHRES 452	HYDR	VOL		WDM 767	VOL		ENGL		REPL

```

***RCHRES 46 HYDR VOL WDM 763 VOL ENGL REPL
***RCHRES 43 HYDR VOL WDM 764 VOL ENGL REPL
*****RCHRES 44 HYDR VOL WDM 765 VOL ENGL REPL

***RCHRES 51 HYDR VOL WDM 766 VOL ENGL REPL
***** POINT OF COMPLIANCE (POC) FLOWS
***COPY 37 OUTPUT MEAN 1 1 12.1 WDM 125 FLOW ENGL REPL
***COPY 45 OUTPUT MEAN 1 1 12.1 WDM 199 FLOW ENGL REPL
***COPY 53 OUTPUT MEAN 1 1 12.1 WDM 399 FLOW ENGL REPL
***COPY 70 OUTPUT MEAN 1 1 12.1 WDM 7000 FLOW ENGL REPL
***COPY 71 OUTPUT MEAN 1 1 12.1 WDM 7001 FLOW ENGL REPL
END EXT TARGETS
    
```

SCHEMATIC

<-Source->	<--Area-->	<-Target->	MBLK	***
<Name> #	<-factor->	<Name> #	Tbl#	***
*** SUB-CATCHMENT 1 all agwo goes to sound				
PERLND 16	3.41	RCHRES 1	6	
PERLND 26	232.36	RCHRES 1	6	
PERLND 34	3.07	RCHRES 1	6	
PERLND 44	38.03	RCHRES 1	6	
PERLND 54	3.87	RCHRES 1	6	
IMPLND 14	56.14	RCHRES 1	2	
*** SUB-CATCHMENT 2 10% of area Gw goes to vaca 90% goes to sound				
PERLND 16	5.56	RCHRES 2	6	
PERLND 26	200.05	RCHRES 2	6	
PERLND 34	0.46	RCHRES 2	6	
PERLND 44	38.71	RCHRES 2	6	
PERLND 16	0.56	RCHRES 135	7	
PERLND 26	20.00	RCHRES 135	7	
PERLND 34	0.05	RCHRES 135	7	
PERLND 44	3.87	RCHRES 135	7	
IMPLND 14	42.22	RCHRES 2	2	
*** SUB-CATCHMENT 23 New subbasin 15 % OF GW GOES TO VACCA 85% TO SOUND				
PERLND 16	3.09	RCHRES 23	6	
PERLND 26	156.15	RCHRES 23	6	
PERLND 34	2.25	RCHRES 23	6	
PERLND 44	45.84	RCHRES 23	6	
PERLND 16	0.46	RCHRES 135	7	
PERLND 26	23.42	RCHRES 135	7	
PERLND 34	0.34	RCHRES 135	7	
PERLND 44	6.88	RCHRES 135	7	
IMPLND 14	58.44	RCHRES 23	2	
*** SUB-CATCHMENT 24 New subbasin 60 % OF GW GOES TO 11 40% TO SOUND				
PERLND 26	135.43	RCHRES 24	6	
PERLND 34	2.02	RCHRES 24	6	
PERLND 44	69.29	RCHRES 24	6	
PERLND 26	81.26	RCHRES 11	7	
PERLND 34	1.21	RCHRES 11	7	
PERLND 44	41.57	RCHRES 11	7	
IMPLND 14	79.98	RCHRES 24	2	
*** SUB-CATCHMENT 3 agwo goes to vaca(135)				
PERLND 16	8.26	RCHRES 3	6	
PERLND 26	108.38	RCHRES 3	6	
PERLND 34	16.02	RCHRES 3	6	
PERLND 44	102.89	RCHRES 3	6	
PERLND 54	0.04	RCHRES 3	6	
PERLND 16	8.26	RCHRES 135	7	
PERLND 26	108.38	RCHRES 135	7	
PERLND 34	16.02	RCHRES 135	7	
PERLND 44	102.89	RCHRES 135	7	
PERLND 54	0.04	RCHRES 135	7	
IMPLND 14	27.30	RCHRES 3	2	

```

*** SUB-CATCHMENT 4 10% of agwo goes to rchres 90% goes to sound
PERLND 16 2.95 RCHRES 4 6
PERLND 26 85.95 RCHRES 4 6
PERLND 34 3.75 RCHRES 4 6
PERLND 44 92.06 RCHRES 4 6
PERLND 16 0.30 RCHRES 4 7
PERLND 26 8.59 RCHRES 4 7
PERLND 34 0.38 RCHRES 4 7
PERLND 44 9.21 RCHRES 4 7
IMPLND 14 18.43 RCHRES 4 2
*** SUB-CATCHMENT 4a 70% of agwo goes to rchres 30% goes to sound
PERLND 16 8.66 RCHRES 4 6
PERLND 26 61.64 RCHRES 4 6
PERLND 34 22.06 RCHRES 4 6
PERLND 44 78.09 RCHRES 4 6
PERLND 54 12.50 RCHRES 4 6
PERLND 16 6.06 RCHRES 4 7
PERLND 26 43.15 RCHRES 4 7
PERLND 34 15.44 RCHRES 4 7
PERLND 44 54.66 RCHRES 4 7
PERLND 54 8.75 RCHRES 4 7
IMPLND 14 29.14 RCHRES 4 2
*** SUB-CATCHMENT 5
PERLND 26 10.29 RCHRES 5 1
PERLND 44 50.05 RCHRES 5 1
PERLND 54 10.74 RCHRES 5 1
IMPLND 14 16.31 RCHRES 5 2
*** SUB-CATCHMENT 6
PERLND 16 1.42 COPY 645 26
PERLND 26 20.38 COPY 645 26
PERLND 34 13.44 COPY 645 26
PERLND 44 11.79 COPY 645 26
PERLND 54 0.82 COPY 645 26
PERLND 16 1.42 RCHRES 53 7
PERLND 26 20.38 RCHRES 53 7
PERLND 34 13.44 RCHRES 53 7
PERLND 44 11.79 RCHRES 53 7
PERLND 54 0.82 RCHRES 53 7
IMPLND 14 6.23 COPY 645 22
*** SUB-CATCHMENT 8
PERLND 44 22.21 RCHRES 35 1
IMPLND 14 6.60 RCHRES 35 2
*** SUB-CATCHMENT 9
PERLND 16 4.98 RCHRES 34 1
PERLND 26 14.38 RCHRES 34 1
PERLND 34 0.05 RCHRES 34 1
PERLND 44 56.71 RCHRES 34 1
PERLND 54 0.01 RCHRES 34 1
IMPLND 14 22.47 RCHRES 34 2
*** SUB-CATCHMENT 10
PERLND 16 4.15 RCHRES 10 1
PERLND 26 31.94 RCHRES 10 1
PERLND 44 95.22 RCHRES 10 1
IMPLND 14 71.98 RCHRES 10 2
*** SUB-CATCHMENT 11 25% OF AGWO GOES TO 15
PERLND 16 0.89 RCHRES 11 6
PERLND 26 217.92 RCHRES 11 6
PERLND 34 1.32 RCHRES 11 6
PERLND 44 65.65 RCHRES 11 6
PERLND 16 0.67 RCHRES 11 7
PERLND 26 163.44 RCHRES 11 7
PERLND 34 0.99 RCHRES 11 7
PERLND 44 49.24 RCHRES 11 7

```

PERLND 16	0.22	RCHRES 15	7
PERLND 26	54.48	RCHRES 15	7
PERLND 34	0.33	RCHRES 15	7
PERLND 44	16.41	RCHRES 15	7
IMPLND 14	230.80	RCHRES 11	2
*** SUB-CATCHMENT 12			
PERLND 16	0.39	RCHRES 12	1
PERLND 26	101.18	RCHRES 12	1
PERLND 34	5.64	RCHRES 12	1
PERLND 44	54.98	RCHRES 12	1
PERLND 54	0.64	RCHRES 12	1
IMPLND 14	79.83	RCHRES 12	2
*** SUB-CATCHMENT 13			
PERLND 16	0.79	RCHRES 13	1
PERLND 26	197.68	RCHRES 13	1
IMPLND 14	27.66	RCHRES 13	2
*** SUB-CATCHMENT 14 50% OF AGWO GOES TO SOUND			
PERLND 16	0.24	RCHRES 14	6
PERLND 26	118.67	RCHRES 14	6
PERLND 34	13.46	RCHRES 14	6
PERLND 44	41.91	RCHRES 14	6
PERLND 16	0.12	RCHRES 14	7
PERLND 26	59.34	RCHRES 14	7
PERLND 34	6.73	RCHRES 14	7
PERLND 44	20.95	RCHRES 14	7
IMPLND 14	20.66	RCHRES 14	2
*** SUB-CATCHMENT 15			
PERLND 16	6.59	RCHRES 15	1
PERLND 26	49.55	RCHRES 15	1
PERLND 34	50.09	RCHRES 15	1
PERLND 44	86.52	RCHRES 15	1
IMPLND 14	19.47	RCHRES 15	2
*** SUB-CATCHMENT 16			
PERLND 16	10.93	RCHRES 16	1
PERLND 26	29.93	RCHRES 16	1
PERLND 34	20.03	RCHRES 16	1
PERLND 44	31.83	RCHRES 16	1
IMPLND 14	15.58	RCHRES 16	2
*** SUB-CATCHMENT 17 AGWO GOES TO SOUND			
PERLND 16	0.90	RCHRES 17	6
PERLND 26	16.31	RCHRES 17	6
PERLND 34	34.82	RCHRES 17	6
PERLND 44	82.11	RCHRES 17	6
PERLND 54	2.19	RCHRES 17	6
IMPLND 14	10.49	RCHRES 17	2
*** SUB-CATCHMENT MC-1			
PERLND 26	0.14	RCHRES 52	1
PERLND 44	9.44	RCHRES 52	1
PERLND 45	0.14	RCHRES 52	1
PERLND 54	0.27	RCHRES 52	1
IMPLND 14	1.98	RCHRES 52	2
*** SUB-CATCHMENT MC-2			
PERLND 16	0.08	RCHRES 53	1
PERLND 26	0.53	RCHRES 53	1
PERLND 34	3.60	RCHRES 53	1
PERLND 44	9.20	RCHRES 53	1
PERLND 45	2.22	RCHRES 53	1
PERLND 54	15.14	RCHRES 53	1
IMPLND 14	2.54	RCHRES 53	2
*** SUB-CATCHMENT MC-3			
PERLND 34	3.70	RCHRES 54	1
PERLND 44	4.91	RCHRES 54	1
PERLND 45	1.07	RCHRES 54	1

PERLND 54	1.84	RCHRES 54	1
IMPLND 14	1.42	RCHRES 54	2
*** SUB-CATCHMENT MC-4			
PERLND 34	0.27	RCHRES 135	1
PERLND 44	16.51	RCHRES 135	1
PERLND 45	4.23	RCHRES 135	1
PERLND 54	11.98	RCHRES 135	1
IMPLND 14	3.31	RCHRES 135	2
*** SUB-CATCHMENT MC-5			
PERLND 26	13.43	RCHRES 35	1
PERLND 44	33.84	RCHRES 35	1
PERLND 54	7.44	RCHRES 35	1
IMPLND 14	0.02	RCHRES 35	2
*** SUB-CATCHMENT MC-6			
PERLND 44	14.10	RCHRES 35	1
PERLND 45	0.09	RCHRES 35	1
PERLND 54	0.90	RCHRES 35	1
IMPLND 14	0.26	RCHRES 35	2
*** SUB-CATCHMENT MC-7			
PERLND 26	11.26	COPY 55	21
PERLND 44	31.80	COPY 55	21
PERLND 54	3.20	COPY 55	21
IMPLND 14	0.03	COPY 55	22

***note: SDN AGWO TO VACCA FARMS (135)NOT TO PONDS

*** SUB-CATCHMENT SDN-1			
PERLND 26	1.97	RCHRES 552	6
PERLND 44	1.29	RCHRES 552	6
PERLND 54	0.20	RCHRES 552	6
PERLND 26	1.97	RCHRES 135	7
PERLND 44	1.29	RCHRES 135	7
PERLND 54	0.20	RCHRES 135	7
IMPLND 14	12.68	RCHRES 552	2

*** SUB-CATCHMENT SDN-1-LWR			
PERLND 44	4.79	RCHRES 552	6
PERLND 54	0.07	RCHRES 552	6
PERLND 44	4.79	RCHRES 135	7
PERLND 54	0.07	RCHRES 135	7
IMPLND 14	0.56	RCHRES 552	2

*** SUB-CATCHMENT SDN-1-OFF			
PERLND 26	23.01	RCHRES 52	6
PERLND 44	3.58	RCHRES 52	6
PERLND 54	1.67	RCHRES 52	6
PERLND 26	23.01	RCHRES 135	7
PERLND 44	3.58	RCHRES 135	7
PERLND 54	1.67	RCHRES 135	7
IMPLND 14	8.00	RCHRES 52	2

*** SUB-CATCHMENT SDN-2X (TO POND)			
PERLND 26	0.63	COPY 61	26
PERLND 44	2.40	COPY 61	26
PERLND 45	0.86	COPY 61	26
PERLND 26	0.63	RCHRES 135	7
PERLND 44	2.40	RCHRES 135	7
PERLND 45	0.86	RCHRES 135	7
IMPLND 14	0.36	COPY 61	22

*** SUB-CATCHMENT SDN-3 (TO POND)			
PERLND 26	23.56	RCHRES 43	6
PERLND 26	23.56	RCHRES 135	7

IMPLND 14	24.30	RCHRES 43	2
*** SUB-CATCHMENT SDN-3X (TO POND)			
PERLND 26	1.61	RCHRES 43	6
***original PERLND area			
***PERLND 45	23.77	RCHRES 43	6
***PERLND AREA TO BE REMOVED = 0.45 AC			
PERLND 80	00.45	RCHRES 43	7
PERLND 45	23.32	RCHRES 43	6
PERLND 26	1.61	RCHRES 135	7
PERLND 45	23.77	RCHRES 135	7
*** SUB-CATCHMENT SDN-4 (TO POND)			
PERLND 26	15.75	COPY 44	26
PERLND 44	1.31	COPY 44	26
PERLND 45	0.99	COPY 44	26
PERLND 26	15.75	RCHRES 135	7
PERLND 44	1.31	RCHRES 135	7
PERLND 45	0.99	RCHRES 135	7
IMPLND 14	12.26	COPY 44	22
*** SUB-CATCHMENT SDN-4X (TO POND)			
PERLND 26	1.92	COPY 44	26
PERLND 44	0.75	COPY 44	26
PERLND 45	8.31	COPY 44	26
PERLND 26	1.92	RCHRES 135	7
PERLND 44	0.75	RCHRES 135	7
PERLND 45	8.31	RCHRES 135	7
IMPLND 14	4.21	COPY 44	22
*** SUB-CATCHMENT IWS-NCPS (TO POND)			
PERLND 26	4.78	RCHRES 242	6
PERLND 26	4.78	RCHRES 135	7
IMPLND 14	30.93	RCHRES 242	2
*** SUB-CATCHMENT IWS-NSMPS (TO POND)			
PERLND 26	2.69	RCHRES 240	6
PERLND 44	1.97	RCHRES 240	6
PERLND 45	0.01	RCHRES 240	6
PERLND 26	2.69	RCHRES 135	7
PERLND 44	1.97	RCHRES 135	7
PERLND 45	0.01	RCHRES 135	7
IMPLND 14	1.95	RCHRES 240	2
*** SUB-CATCHMENT NEPL (TO POND)			
PERLND 26	10.00	RCHRES 452	6
PERLND 26	10.00	RCHRES 135	7
IMPLND 14	6.00	RCHRES 451	2
IMPLND 14	26.29	RCHRES 452	2
*** SUB-CATCHMENT CARGO (TO POND)			
IMPLND 14	8.12	RCHRES 46	2
*** SUB-CATCHMENT SDN3AI (TO VAULT)			
***original IMPLND area			
***IMPLND 14	5.87	RCHRES 37	2
***IMPLND AREA TO BE REMOVED = 5.62 AC			
IMPLND 14	0.25	RCHRES 37	2
PERLND 80	5.62	RCHRES 37	7
*** SUB-CATCHMENT SDN3AO (TO POND)			
PERLND 26	0.08	RCHRES 237	6
PERLND 44	0.03	RCHRES 237	6

```

***PERLND AREA TO BE REMOVED = 10.63 AC
***PERLND AREA TO BE REMOVED = 4.55 AC
***original PERLND area
***PERLND 45          22.12      RCHRES 237      6
PERLND 80            10.63      RCHRES 237      7
PERLND 80            4.55      RCHRES 237      7
PERLND 45            6.94      RCHRES 237      6
PERLND 26            0.08      RCHRES 135      7
PERLND 44            0.03      RCHRES 135      7
PERLND 45            22.12      RCHRES 135      7
***original IMPLND area
***IMPLND 14         2.35      RCHRES 237      2
***IMPLND AREA TO BE REMOVED = 1.66 AC
IMPLND 14            0.69      RCHRES 237      2
PERLND 80            1.66      RCHRES 237      7

*** SUB-CATCHMENT SDW10 (TO POND)SDW1A0. +PERLND FOR SDW1AI
*** SUB-CATCHMENT SDW10 (TO POND)MIS NAMED
PERLND 26            4.28      RCHRES 247      6
PERLND 44            0.69      RCHRES 247      6
***PERLND AREA TO BE REMOVED = 17.08 AC
***PERLND AREA TO BE REMOVED = 1.53 AC
***original PERLND area
***PERLND 45          32.44      RCHRES 247      6
PERLND 80            17.08      RCHRES 247      7
PERLND 80            1.53      RCHRES 247      7
PERLND 45            13.83      RCHRES 247      6
PERLND 26            4.28      RCHRES 135      7
PERLND 44            0.69      RCHRES 135      7
PERLND 45            32.44      RCHRES 135      7
IMPLND 14            1.64      RCHRES 247      2

*** SUB-CATCHMENT SDW1AI (TO VAULT)CORRECT NAME
*** SUB-CATCHMENT SDN1AI (TO VAULT)*** MIS NAMES
***original IMPLND area
***IMPLND 14         13.78      RCHRES 147      2
***IMPLND AREA TO BE REMOVED = 12.6 AC
IMPLND 14            1.18      RCHRES 147      2
PERLND 80            12.6      RCHRES 147      7

*** SUB-CATCHMENT SDW1B (TO POND)
*** AGWO TO 35, AS 57 IS D/S OF VACCA FARMS (135)
PERLND 26            21.25      RCHRES 570      6
PERLND 44            2.39      RCHRES 570      6
***PERLND AREA TO BE REMOVED = 35.32 AC
***PERLND AREA TO BE REMOVED = 2.92 AC
***original PERLND area
***PERLND 45          46.26      RCHRES 570      6
PERLND 80            35.32      RCHRES 570      7
PERLND 80            2.92      RCHRES 570      7
PERLND 45            8.02      RCHRES 570      6
PERLND 26            21.25      RCHRES 35      7
PERLND 44            2.39      RCHRES 35      7
PERLND 45            46.26      RCHRES 35      7
***original IMPLND area
***IMPLND 14         26.95      RCHRES 570      2
***IMPLND AREA TO BE REMOVED = 20.69 AC
IMPLND 14            6.26      RCHRES 570      2
PERLND 80            20.69      RCHRES 570      7
***ADD SDW2 FROM WALKER CREEK
PERLND 80            1.06      RCHRES 570      7
*** this impervious does not go to miller but walker
IMPLND 14            0.70      RCHRES 570      2

```

```

PERLND 80          0.70      RCHRES 570      7
*** FIND OUT WHERE THIS GOES?????
***NEW AREAS ADDED 11/19/01
***SDS3A
PERLND 26          1.72      RCHRES 37      7
IMPLND 14          0.70      RCHRES 37      2
***SDW-2
PERLND 26          11.06     RCHRES 35      7
PERLND 45          1.09      RCHRES 35      7

*** SPECIAL INFILTRATION PERLNDs
PERLND 47          2.0       RCHRES 35      7
PERLND 57          2.0       RCHRES 16      7
***SDE4 0.04 ACRES OF PERLND 26
PERLND 26          0.04      RCHRES 35      7

*** ADD SUB-CATCHMENT IWS-PRIMARY TO PREDEVELOPEMENT ONLY

***ROUTING FOR MILLER CREEK
*** M1 TO M2 TO M3 TO STORAGE 50.  M4 TO M5 TO STORAGE 50
RCHRES 1          RCHRES 2      4
RCHRES 23         RCHRES 24     4
RCHRES 24         RCHRES 3      3
RCHRES 2          RCHRES 3      3
RCHRES 3          RCHRES 33     3
RCHRES 33         RCHRES 50     3
RCHRES 4          RCHRES 5      4
RCHRES 5          RCHRES 50     3
*** PONDS TO 52, 53 & 54
RCHRES 242        RCHRES 240    5
*** OVERFLOW ONLY TO 61
RCHRES 240        RCHRES 51     5
COPY 61           RCHRES 51    12
COPY 44           RCHRES 51    12
RCHRES 51         RCHRES 52     3
RCHRES 43         RCHRES 54     3
*** 2 NEPL VAULTS* (FK-changed to eliminate run-of-river tables)
RCHRES 451        COPY 45       11
RCHRES 452        COPY 45       11
COPY 45           COPY 645     10
COPY 645          RCHRES 53    12
RCHRES 46         RCHRES 53     3
*** NEW STREAM REACH 52 TO LAKE REBA 53 TO RDF 54 (FK-changed to insert new POC at
Lake Reba)
RCHRES 552        RCHRES 52     3
RCHRES 52         RCHRES 53     3
RCHRES 53         COPY 53      11
COPY 53           RCHRES 54    12
RCHRES 50         RCHRES 54     3
*** RDF 54 TO 35
RCHRES 54         RCHRES 135    3
<-Source->        <--Area-->    <-Target->    MBLK    ***
<Name> #          <-factor->    <Name> #      Tbl#    ***
*** PONDS TO 34
RCHRES 37         COPY 37       11
RCHRES 237        COPY 37       11
COPY 37           RCHRES 135    12
*** SDW1A flow to bypass added (FK, June 2001)
SDW1AI VAULT FLOW TO INFILTRATION 1
RCHRES 147        RCHRES 47     4
SDW1AI VAULT FLOW TO BYPASS
RCHRES 147        COPY 70       15
STORMWATER Q 1ST EXIT AT POND G (Bypass)

```

```

RCHRES 247          COPY 70 14
RCHRES 247          COPY 66 14
2ND EXIT TO INFILTRATION TANK-MILLER CREEK ***
RCHRES 247          RCHRES 47 5
RCHRES 247          COPY 69 15
STORMWATER Q 1ST EXIT TO BYPASS ***
RCHRES 47           COPY 70 14
2ND EXIT TO SOIL AND MILLER CREEK ***
***REMOVE CONNECTION FOR INFILTRATION OUTLET. THIS FLOW IS NOW GOING TO AGWLI FOR
INFILTRATION PERLND
RCHRES 47           COPY 70 15 ***
COPY BLOCK FOR OUTPUT PURPOSES ***
RCHRES 47           COPY 62 14
RCHRES 47           COPY 63 15
RCHRES 147          COPY 67 14
RCHRES 147          COPY 68 15
*** --> output SDW1A infiltration discharge to WDM dataset 5 <--
*** SEND FLOW TO PERLND 47 FOR INFILTRATION OF SECOND OUTLET
*** 2 acre area for infiltration before stream reach
***REDUCED FOR DEEP FRAC FROM 0.5 TO 0.335
RCHRES 47           0.335 PERLND 47 28
COPY 70             RCHRES 135 12
RCHRES 34           RCHRES 135 4
RCHRES 34           RCHRES 135 5
RCHRES 135          RCHRES 35 3
RCHRES 10           RCHRES 16 3
*** PONDS TO 35
*** Configuration changed to flow splitter to Pond D and Infiltration Basin 3 (FK,
June 2001)
STORM Q - 1ST EXIT OF FLOW SPLITTER TO POND D ***
RCHRES 570          RCHRES 57 4
INFILTRATION Q - 2ND EXIT OF FLOW SPLITTER TO SOIL ***
RCHRES 570          RCHRES 257 5
STORM Q EXIT OF POND D TO MILLER CREEK ***
RCHRES 57           COPY 71 11
COPY BLOCK FOR OUTPUT PURPOSES ***
RCHRES 57           COPY 357 11
RCHRES 570          COPY 64 14
RCHRES 570          COPY 65 15
*** --> output SDW1B infiltration discharge to WDM dataset 6 <--
RCHRES 257          COPY 56 14
***ROUTE WATER TO AGWLI FOR PERLND 57 INFILTRATION PERLND
***2 ACRE AREA for infiltration before stream reach
***REDUCED FOR DEEP FRAC FROM 0.5 TO 0.335
RCHRES 257          .335 PERLND 57 28
RCHRES 257          COPY 71 14
***REMOVE INFILTRATION FOR SECOND OUTLET ROUTE WATER TO AGWLI
RCHRES 257          COPY 71 15***
COPY 71             RCHRES 35 12
RCHRES 35           COPY 55 11
COPY 55             RCHRES 16 12
RCHRES 11           RCHRES 15 3
RCHRES 13           RCHRES 12 4
RCHRES 13           RCHRES 12 5
RCHRES 12           RCHRES 15 3
RCHRES 16           RCHRES 15 3
RCHRES 14           RCHRES 17 3
RCHRES 15           RCHRES 17 3
END SCHEMATIC

```

NETWORK

```

***
<NAME> # <MEMBER> SSYSSGAP<--MULT-->TRAN <--TARGET VOLS> <--MEMBER-->
# # <NAME> # # <GRP> <NAME> # # ***

```

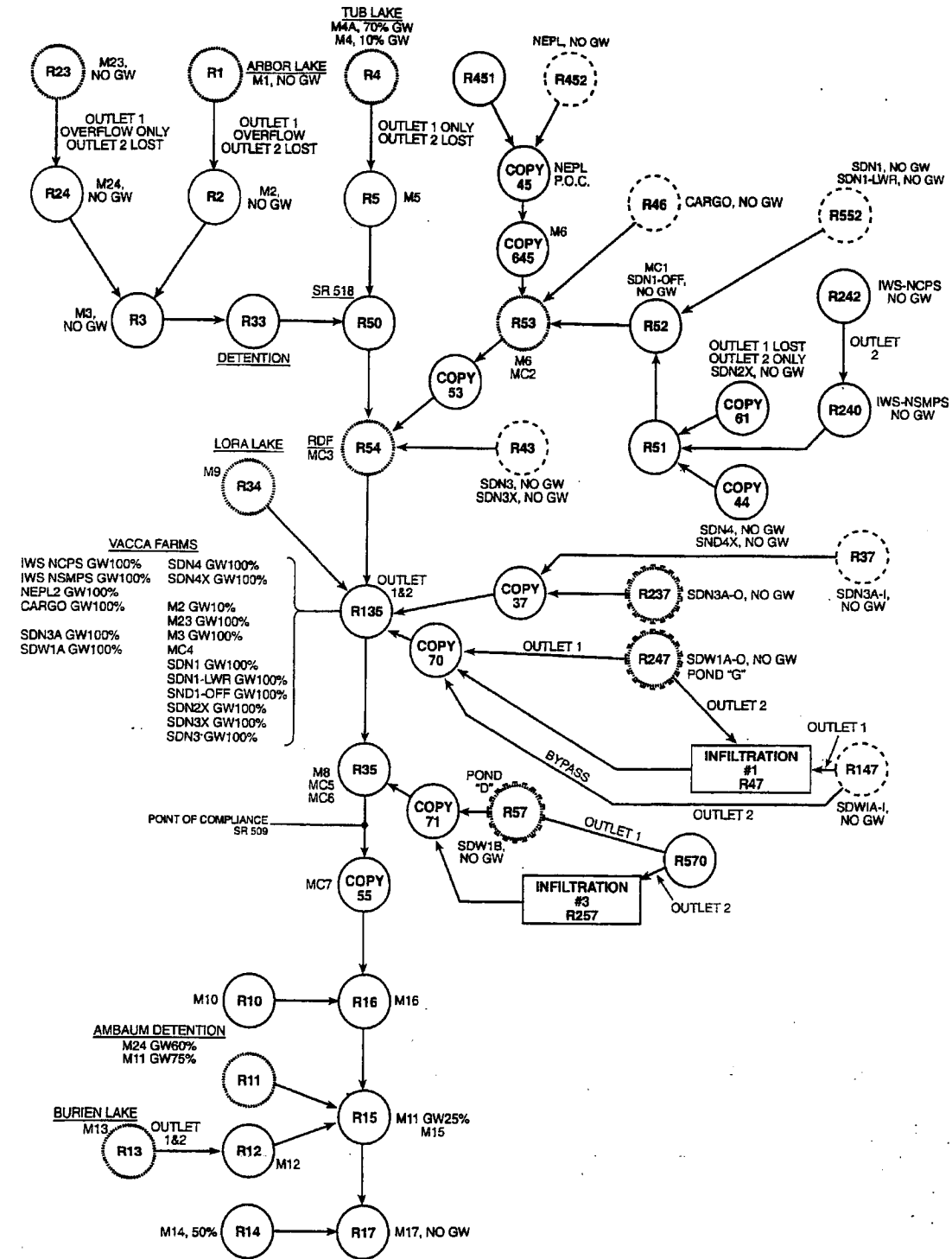

Notes: GW routed to reach unless otherwise noted.
 Reaches have one outlet unless otherwise noted.
 Reach table # is the same as reach # unless otherwise noted.

Parametrix, Inc. Port of Seattle 660-2912-0010(228) 12/91 (1)

GW Ground Water Routing



HSPF Model Schematic
 Miller Creek
 Low Flow Analysis
 2006 Conditions

**MILLER CREEK WATERSHED
HSPF INPUT FILES**

- 1994 CONDITIONS
- 2006 CONDITIONS

CERTIFICATE OF ENGINEER

The technical material and data for the Miller Creek watershed and Walker Creek watershed low flow-specific HSPF modeling were prepared under the supervision and direction of the undersigned, whose seal, as a professional engineer licensed to practice as such, is affixed below.

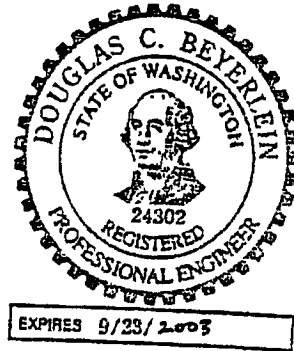

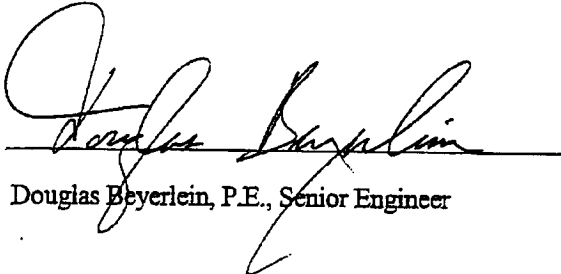
Douglas Beyerlein, P.E., Senior Engineer

(affix seal here)

*Low Streamflow Analysis
STIA Master Plan Update Improvements*

*December 2001
556-2912-001(28B)*

AR 020291

1994 CONDITIONS

AR 020292

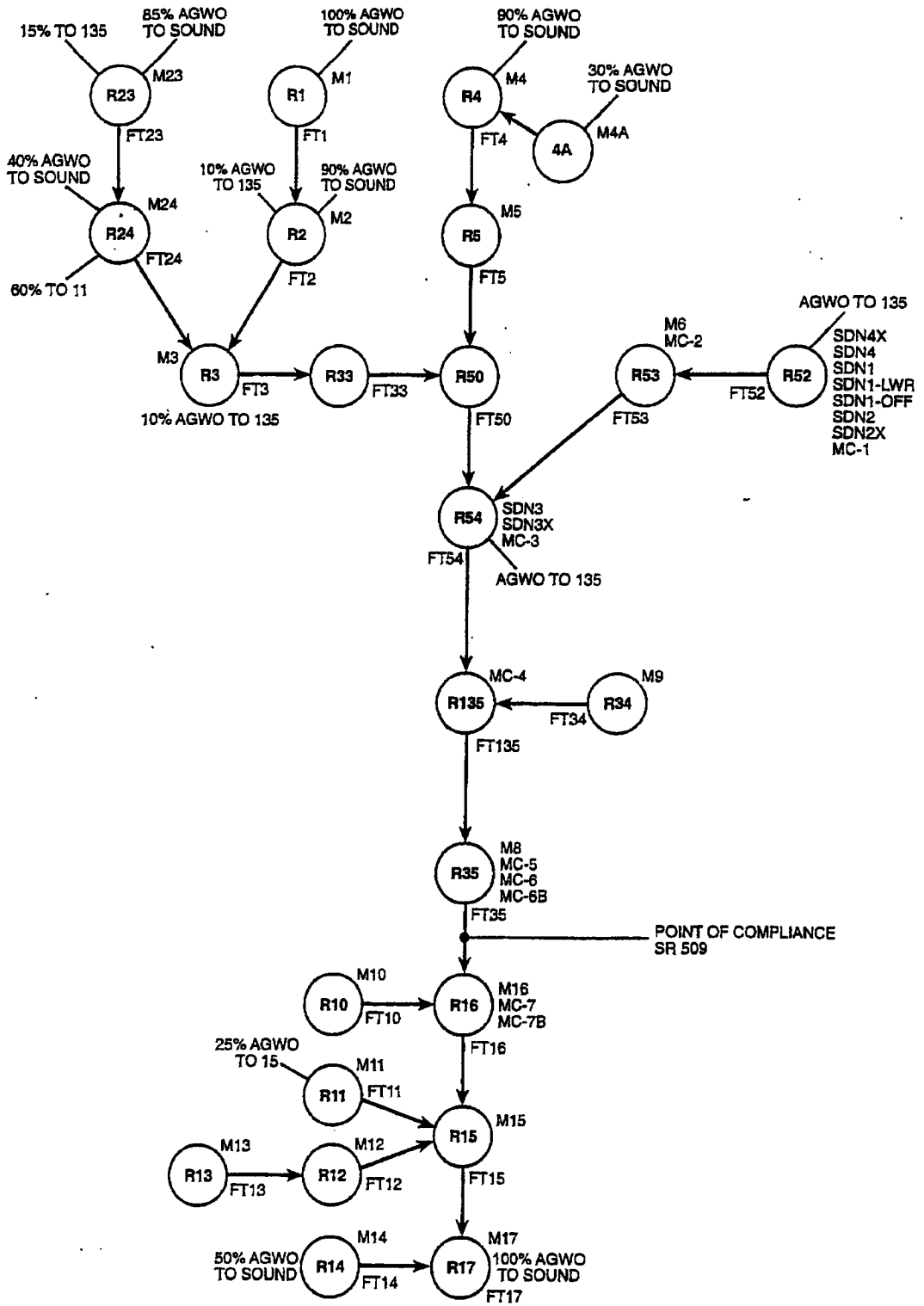

Parametrix, Inc. Port of Seattle/558-2912-001/01(28B) 12/01 (K)

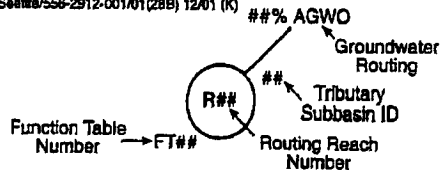

**HSPF Model Schematic
Miller Creek
Low Flow Analysis
1994 Conditions**

RUN

GLOBAL

```

*** FILE: mill65.inp REVISED Aug 2000. Joe Brascher(atc)
*** for parameterix
*** SEATAC AIRPORT HSPF BASIN MODEL OF MILLER CREEK
*** - POST-MILLER CK DETENTION FACILITY 10/92-6/93
*** m23 AND M24 new area west of m2. Flows to rdf
*** Calibration file run for FOUR YEARS using full length calibration run 1990
*** data for initial conditions
MILLER CREEK BASIN HSPF MODEL
START 1990 10 1 0 0 END 1994 9 30 24 0
RUN INTERP OUTPUT LEVEL 3
RESUME 0 RUN 1

```

END GLOBAL

FILES

```

<type> <fun>***<-----fname----->
MESSU 24 D:\PARA\SEATAC\MILLER\lowflow\MILL.MES
WDM 25 D:\PARA\SEATAC\MILLER\lowflow\Mlowflow.wdm
61 D:\PARA\SEATAC\MILLER\lowflow\PER.L61
62 D:\PARA\SEATAC\MILLER\lowflow\RCH.L62

```

END FILES

OPN SEQUENCE

```

INGRP INDELT 01:00
PERLND 14
PERLND 16
PERLND 18
PERLND 24
PERLND 26
PERLND 28
PERLND 34
PERLND 44
PERLND 54
IMPLND 14
RCHRES 1
RCHRES 23
RCHRES 24
RCHRES 2
RCHRES 3
RCHRES 33
RCHRES 4
RCHRES 5
RCHRES 50
RCHRES 52
RCHRES 53
RCHRES 54
RCHRES 34
RCHRES 135
RCHRES 35
RCHRES 10
RCHRES 16
RCHRES 11
RCHRES 13
RCHRES 12
RCHRES 15
RCHRES 14
RCHRES 17

```

END INGRP

END OPN SEQUENCE

COPY

TIMESERIES

Copy-opn
 # - # NPT NMN
 1 5 1
 END TIMESERIES
 END COPY

PERLND

GEN-INFO

<PLS > Name NBLKS Unit-systems Printer
 # - # User t-series Engl Metr
 in out
 14 TFF- TILL FOR FLT 1 1 1 1 61 0
 16 TFM- TILL FOR MOD 1 1 1 1 61 0
 18 TFS- TILL FOR STP 1 1 1 1 61 0
 24 TGF- TILL GR FLT 1 1 1 1 61 0
 26 TGM- TILL GR MOD 1 1 1 1 61 0
 28 TGS- TILL GR STP 1 1 1 1 61 0
 34 OF - OUTWASH FOR 1 1 1 1 61 0
 44 OG - OUTWASH GR 1 1 1 1 61 0
 ***PERLND FOR NEW AIRPORT FILL; NONE IN CALIBRATION
 45 AIRPORT FILL 1 1 1 1 61 0
 54 SA - WETLANDS 1 1 1 1 61 0
 64 RES- GROUNDWATER 1 1 1 1 61 0

END GEN-INFO

ACTIVITY

<PLS > ***** Active Sections *****
 # - # ATMP SNOW PWAT SED PST PWG PQAL MSTL PEST NITR PHOS TRAC
 14 200 0 0 1 0 0 0 0 0 0 0 0 0

END ACTIVITY

PRINT-INFO

<PLS > ***** Print-flags ***** PIVL PYR
 # - # ATMP SNOW PWAT SED PST PWG PQAL MSTL PEST NITR PHOS TRAC *****
 14 200 0 0 5 0 0 0 0 0 0 0 0 0 1 9

END PRINT-INFO

PWAT-PARM1

<PLS > ***** Flags *****
 # - # CSNO RTOP UZFG VCS VUZ VNN VIFW VIRC VLE
 14 0 0 0 0 0 0 0 0 0
 16 0 0 0 0 0 0 0 0 0
 18 0 0 0 0 0 0 0 0 0
 24 0 0 0 0 0 0 0 0 0
 26 0 0 0 0 0 0 0 0 0
 28 0 0 0 0 0 0 0 0 0
 34 0 0 0 0 0 0 0 0 0
 44 0 0 0 0 0 0 0 0 0
 45 0 0 0 0 0 0 0 0 0
 54 0 0 0 0 0 0 0 0 0
 64 0 0 0 0 0 0 0 0 0

END PWAT-PARM1

PWAT-PARM2

<PLS > ***
 # - # ***FOREST LZSN INFILT LSUR SLSUR KVARV AGWRC
 14 9.0000 0.3200 400.00 0.0500 0.5000 0.9960
 16 9.0000 0.3200 400.00 0.1000 0.5000 0.9960
 18 9.0000 0.3200 200.00 0.2000 0.5000 0.9960
 24 9.0000 0.1200 400.00 0.0500 0.5000 0.9960
 26 9.0000 0.1200 400.00 0.1000 0.5000 0.9960
 28 9.0000 0.1200 200.00 0.2000 0.5000 0.9960
 34 10.0000 2.0000 400.00 0.0500 0.3000 0.9960
 44 10.0000 0.8000 400.00 0.0500 0.3000 0.9960
 45 7.5000 0.0200 300.00 0.0700 0.0000 0.9000
 54 8.0000 2.0000 100.00 0.0010 0.5000 0.9960

END PWAT-PARM2

```

PWAT-PARM3
<PLS >***
# - #*** PETMAX    PETMIN    INFEXP    INFILD    DEEPFR    BASETP    AGWETP
14          2.0000    2.0000    2.0000    2.0000    0.33      0.00      0.0
16          2.0000    2.0000    2.0000    2.0000    0.33      0.00      0.0
18          2.0000    2.0000    2.0000    2.0000    0.33      0.00      0.0
24          2.0000    2.0000    2.0000    2.0000    0.33      0.00      0.
26          2.0000    2.0000    2.0000    2.0000    0.33      0.         0.
28          2.0000    2.0000    2.0000    2.0000    0.33      0.         0.
34          2.0000    2.0000    2.0000    2.0000    0.33      0.00      0.0
44          2.0000    2.0000    2.0000    2.0000    0.33      0.         0.
54          10.000   2.0000    2.0000    2.0000    0.33      0.         0.7
    
```

END PWAT-PARM3

```

PWAT-PARM4
<PLS >
# - #          CEPSC    UZSN    NSUR    INTFW    IRC    LZETP***
14          0.2000    1.5000    0.3500    9.000    0.7000    0.7000
16          0.2000    0.7500    0.3500    9.000    0.7000    0.7000
18          0.2000    0.4500    0.3500    9.000    0.3000    0.7000
24          0.1000    0.7500    0.2500    9.000    0.7000    0.2500
26          0.1000    0.3750    0.2500    9.000    0.7000    0.2500
28          0.1000    0.2250    0.2500    9.000    0.3000    0.2500
34          0.2000    0.7500    0.3500    0.000    0.7000    0.7000
44          0.1000    0.7500    0.2500    0.000    0.7000    0.2500
54          0.1000    2.2500    0.5000    1.000    0.7000    0.8000
    
```

END PWAT-PARM4

```

PWAT-STATE1
<PLS > PWATER state variables***
# - #*** CEPS    SURS    UZS    IFWS    LZS    AGWS    GWVS
16          0.000    0.     0.0010    0.00    0.941    3.108    0.048
26          0.000    0.     0.0010    0.00    7.672    3.341    0.071
34          0.000    0.     0.0010    0.00    1.187    3.776    0.052
44          0.000    0.     0.0040    0.00    9.402    4.905    0.104
45          0.000    0.     0.0000    0.00    2.000    2.000    0.000
54          0.000    0.     0.0960    0.00    3.211    0.000    0.000
14          0.078    0.     0.2500    0.10    2.000    2.000    0.000
18          0.078    0.     0.2500    0.10    2.000    2.000    0.000
24          0.051    0.     0.2500    0.10    2.000    2.000    0.000
28          0.051    0.     0.2500    0.10    2.000    2.000    0.000
64          0.051    0.     0.2500    0.10    2.000    2.000    0.000
    
```

END PWAT-STATE1

END PERLND

IMPLND

```

GEN-INFO
<ILS >      Name          Unit-systems    Printer
# - #          User t-series Engl Metr
# - #          in out
14    IMPERVIOUS          1    1    1    60    0
    
```

END GEN-INFO

```

ACTIVITY
<ILS > ***** Active Sections *****
# - # ATMP SNOW IWAT SLD IWG IQAL ***
14    0    0    1    0    0    0
    
```

END ACTIVITY

```

PRINT-INFO
<ILS > ***** Print-flags ***** PIVL PYR
# - # ATMP SNOW IWAT SLD IWG IQAL *****
14    0    0    6    0    0    0    1    9
    
```

END PRINT-INFO

```

IWAT-PARM1
<ILS >      Flags
# - # CSNO RTOP VRS VNN RTLI ***
14    0    0    0    0    0
    
```

```

END IWAT-PARM1
IWAT-PARM2
<ILS >
# - #      LSUR      SLSUR      NSUR      RETSC
14      100.00    0.0100    0.1000    0.1000
END IWAT-PARM2
IWAT-PARM3
<ILS >
# - #      PETMAX    PETMIN
14
END IWAT-PARM3
IWAT-STATE1
<ILS > IWATER state variables
# - #      RETS      SURS
14      1.0000E-3  1.0000E-3
END IWAT-STATE1
END IMPLND

```

EXT SOURCES

*** NOTE: The only RCHRES that precip and PET are applied to are lakes.

```

<-Volume-> <Member> Ssysgap<--Mult-->Tran <-Target vols> <-Grp> <-Member->
<Name> # <Name> # tem strg<-factor-->strg <Name> # # <Name> # #
*** PRECIP/EVAP TO PERVIOUS/IMPERV SURFACES
WDM 1002 PREC ENGLZERO 1.00 PERLND 14 200 EXTNL PREC
WDM 1002 PREC ENGLZERO 1.00 IMPLND 14 EXTNL PREC
WDM 1 EVAP ENGLZERO 0.8 PERLND 14 18 EXTNL PETINP
WDM 1 EVAP ENGLZERO 0.8 PERLND 24 28 EXTNL PETINP
WDM 1 EVAP ENGLZERO 0.8 PERLND 34 54 EXTNL PETINP
WDM 1 EVAP ENGLZERO 0.8 PERLND 64 EXTNL PETINP
WDM 1 EVAP ENGLZERO 0.8 IMPLND 14 EXTNL PETINP
*** PRECIP/EVAP TO LAKES
WDM 1002 PREC ENGLZERO RCHRES 1 EXTNL PREC
WDM 1 EVAP ENGLZERO 0.8 RCHRES 1 EXTNL POTEV
WDM 1002 PREC ENGLZERO RCHRES 4 EXTNL PREC
WDM 1 EVAP ENGLZERO 0.8 RCHRES 4 EXTNL POTEV
WDM 1 EVAP ENGLZERO 0.8 RCHRES 1 EXTNL POTEV
WDM 1002 PREC ENGLZERO RCHRES 1 EXTNL PREC
WDM 1 EVAP ENGLZERO 0.8 RCHRES 4 EXTNL POTEV
WDM 1002 PREC ENGLZERO RCHRES 4 EXTNL PREC
WDM 1002 PREC ENGLZERO RCHRES 11 EXTNL PREC
WDM 1 EVAP ENGLZERO 0.8 RCHRES 11 EXTNL POTEV
WDM 1002 PREC ENGLZERO RCHRES 13 EXTNL PREC
WDM 1 EVAP ENGLZERO 0.8 RCHRES 13 EXTNL POTEV
WDM 1002 PREC ENGLZERO RCHRES 23 EXTNL PREC
WDM 1 EVAP ENGLZERO 0.8 RCHRES 23 EXTNL POTEV
WDM 1002 PREC ENGLZERO RCHRES 34 EXTNL PREC
WDM 1 EVAP ENGLZERO 0.8 RCHRES 34 EXTNL POTEV
WDM 1002 PREC ENGLZERO RCHRES 53 EXTNL PREC
WDM 1 EVAP ENGLZERO 0.8 RCHRES 53 EXTNL POTEV
WDM 1002 PREC ENGLZERO RCHRES 54 EXTNL PREC
WDM 1 EVAP ENGLZERO 0.8 RCHRES 54 EXTNL POTEV

```

END EXT SOURCES

EXT TARGETS

```

<-Volume-> <-Grp> <-Member-><--Mult-->Tran <-Volume-> <Member> Tsys Tgap Amd ***
<Name> # <Name> # #<-factor-->strg <Name> # <Name> tem strg strg***
*** UPPER MILLER CREEK GROUNDWATER PUMPING
COPY *** 1 OUTPUT MEAN 1 12.1 WDM 18 FLOW ENGL REPL
*** GAUGE POINTS (17=MOUTH, 54=MILLER RDF, 50=SR 518, 18=WALKER CK)
RCHRES 35 HYDR RO WDM 8035 FLOW ENGL REPL

```

```

RCHRES 17 HYDR RO WDM 33 FLOW ENGL REPL
RCHRES 54 HYDR RO WDM 34 FLOW ENGL REPL
RCHRES 50 HYDR RO *** WDM 35 FLOW ENGL REPL
RCHRES 18 HYDR RO *** WDM 36 FLOW ENGL REPL
*** MISC (20=WALKER WETLAND, 55=SR509, 56=1ST AVE, 1=ARBOR LAKE)
RCHRES 23 HYDR STAGE *** WDM 91 STAG ENGL REPL
RCHRES 20 HYDR RO *** WDM 37 FLOW ENGL REPL
RCHRES 55 HYDR RO *** WDM 38 FLOW ENGL REPL
RCHRES 62 HYDR RO *** WDM 39 FLOW ENGL REPL
RCHRES 1 HYDR RO *** WDM 80 FLOW ENGL REPL
<-Volume-> <-Grp> <-Member-><--Mult-->Tran <-Volume-> <Member> Tsys Tgap Amd ***
<Name> # <Name> # <-factor->strg <Name> # <Name> tem strg strg***
***MOUTH
RCHRES 54 HYDR RO 1 1 0.000419 *** WDM 60 SIMQ ENGL REPL
RCHRES 17 HYDR RO 1 1 0.000213 *** WDM 70 SIMQ ENGL REPL
END EXT TARGETS

```

SCHEMATIC

```

<-Source-> <--Area--> <-Target-> MBLK ***
<Name> # <-factor-> <Name> # Tbl# ***
*** SUB-CATCHMENT 1 all agwo goes to sound
PERLND 16 3.41 RCHRES 1 6
PERLND 26 232.36 RCHRES 1 6
PERLND 34 3.07 RCHRES 1 6
PERLND 44 38.03 RCHRES 1 6
PERLND 54 3.87 RCHRES 1 6
IMPLND 14 56.14 RCHRES 1 2
*** SUB-CATCHMENT 2 10% of area GW goes to vaca 90% goes to sound
PERLND 16 5.56 RCHRES 2 6
PERLND 26 200.05 RCHRES 2 6
PERLND 34 0.46 RCHRES 2 6
PERLND 44 38.71 RCHRES 2 6
PERLND 16 0.56 RCHRES 135 7
PERLND 26 20.01 RCHRES 135 7
PERLND 34 0.05 RCHRES 135 7
PERLND 44 3.87 RCHRES 135 7
IMPLND 14 42.22 RCHRES 2 2
*** SUB-CATCHMENT 23 New subbasin 15 % OF GW GOES TO VACCA 85% TO SOUND
PERLND 16 3.09 RCHRES 23 6
PERLND 26 156.15 RCHRES 23 6
PERLND 34 2.25 RCHRES 23 6
PERLND 44 45.84 RCHRES 23 6
PERLND 16 0.46 RCHRES 135 7
PERLND 26 23.42 RCHRES 135 7
PERLND 34 0.34 RCHRES 135 7
PERLND 44 6.88 RCHRES 135 7
IMPLND 14 58.44 RCHRES 23 2
*** SUB-CATCHMENT 24 New subbasin 60 % OF GW GOES TO 11 40% TO SOUND
PERLND 26 135.43 RCHRES 24 6
PERLND 34 2.02 RCHRES 24 6
PERLND 44 69.29 RCHRES 24 6
PERLND 26 81.26 RCHRES 11 7
PERLND 34 1.21 RCHRES 11 7
PERLND 44 41.57 RCHRES 11 7
IMPLND 14 79.98 RCHRES 24 2
*** SUB-CATCHMENT 3 agwo goes to vaca(135)
PERLND 16 8.26 RCHRES 3 6
PERLND 26 108.38 RCHRES 3 6
PERLND 34 16.02 RCHRES 3 6
PERLND 44 102.89 RCHRES 3 6
PERLND 54 0.04 RCHRES 3 6
PERLND 16 8.26 RCHRES 135 7
PERLND 26 108.38 RCHRES 135 7

```

PERLND	34	16.02	RCHRES	135	7
PERLND	44	102.89	RCHRES	135	7
PERLND	54	0.04	RCHRES	135	7
IMPLND	14	27.30	RCHRES	3	2
*** SUB-CATCHMENT 4 10% of agwo goes to rchres 90% goes to sound					
PERLND	16	2.95	RCHRES	4	6
PERLND	26	85.95	RCHRES	4	6
PERLND	34	3.75	RCHRES	4	6
PERLND	44	92.06	RCHRES	4	6
PERLND	16	0.30	RCHRES	4	7
PERLND	26	8.60	RCHRES	4	7
PERLND	34	0.38	RCHRES	4	7
PERLND	44	9.21	RCHRES	4	7
IMPLND	14	18.43	RCHRES	4	2
*** SUB-CATCHMENT 4a.70% of agwo goes to rchres 30% goes to sound					
PERLND	16	8.66	RCHRES	4	6
PERLND	26	61.64	RCHRES	4	6
PERLND	34	22.06	RCHRES	4	6
PERLND	44	78.09	RCHRES	4	6
PERLND	54	12.50	RCHRES	4	6
PERLND	16	6.06	RCHRES	4	7
PERLND	26	43.15	RCHRES	4	7
PERLND	34	15.44	RCHRES	4	7
PERLND	44	54.66	RCHRES	4	7
PERLND	54	8.75	RCHRES	4	7
IMPLND	14	29.14	RCHRES	4	2
*** SUB-CATCHMENT 5					
PERLND	26	10.29	RCHRES	5	1
PERLND	44	50.04	RCHRES	5	1
PERLND	54	10.74	RCHRES	5	1
IMPLND	14	16.31	RCHRES	5	2
*** SUB-CATCHMENT 6					
PERLND	16	10.66	RCHRES	53	1
PERLND	26	41.08	RCHRES	53	1
PERLND	34	21.75	RCHRES	53	1
PERLND	44	13.39	RCHRES	53	1
PERLND	54	0.82	RCHRES	53	1
IMPLND	14	7.14	RCHRES	53	2
*** SUB-CATCHMENT 8					
PERLND	44	22.21	RCHRES	35	1
IMPLND	14	6.60	RCHRES	35	2
*** SUB-CATCHMENT 9					
PERLND	16	4.94	RCHRES	34	1
PERLND	26	14.32	RCHRES	34	1
PERLND	34	0.05	RCHRES	34	1
PERLND	44	56.70	RCHRES	34	1
PERLND	54	0.01	RCHRES	34	1
IMPLND	14	22.46	RCHRES	34	2
*** SUB-CATCHMENT 10					
PERLND	16	4.15	RCHRES	10	1
PERLND	26	31.94	RCHRES	10	1
PERLND	44	95.23	RCHRES	10	1
IMPLND	14	71.97	RCHRES	10	2
*** SUB-CATCHMENT 11 25% OF AGWO GOES TO 15					
PERLND	16	0.89	RCHRES	11	6
PERLND	26	217.92	RCHRES	11	6
PERLND	34	1.32	RCHRES	11	6
PERLND	44	65.65	RCHRES	11	6
PERLND	16	0.67	RCHRES	11	7
PERLND	26	163.44	RCHRES	11	7
PERLND	34	0.99	RCHRES	11	7
PERLND	44	49.24	RCHRES	11	7
PERLND	16	0.22	RCHRES	15	7

PERLND 26	54.48	RCHRES 15	7
PERLND 34	0.33	RCHRES 15	7
PERLND 44	16.41	RCHRES 15	7
IMPLND 14	230.80	RCHRES 11	2
*** SUB-CATCHMENT 12			
PERLND 16	0.39	RCHRES 12	1
PERLND 26	101.18	RCHRES 12	1
PERLND 34	5.64	RCHRES 12	1
PERLND 44	54.98	RCHRES 12	1
PERLND 54	0.64	RCHRES 12	1
IMPLND 14	79.83	RCHRES 12	2
*** SUB-CATCHMENT 13			
PERLND 16	0.79	RCHRES 13	1
PERLND 26	197.68	RCHRES 13	1
IMPLND 14	27.66	RCHRES 13	2
*** SUB-CATCHMENT 14 50% OF AGWO GOES TO SOUND			
PERLND 16	0.24	RCHRES 14	6
PERLND 26	118.67	RCHRES 14	6
PERLND 34	13.46	RCHRES 14	6
PERLND 44	41.91	RCHRES 14	6
PERLND 16	0.12	RCHRES 14	7
PERLND 26	59.34	RCHRES 14	7
PERLND 34	6.73	RCHRES 14	7
PERLND 44	20.95	RCHRES 14	7
IMPLND 14	20.66	RCHRES 14	2
*** SUB-CATCHMENT 15			
PERLND 16	6.59	RCHRES 15	1
PERLND 26	49.55	RCHRES 15	1
PERLND 34	50.09	RCHRES 15	1
PERLND 44	86.52	RCHRES 15	1
IMPLND 14	19.47	RCHRES 15	2
*** SUB-CATCHMENT 16			
PERLND 16	10.93	RCHRES 16	1
PERLND 26	30.30	RCHRES 16	1
PERLND 34	20.03	RCHRES 16	1
PERLND 44	31.42	RCHRES 16	1
IMPLND 14	15.54	RCHRES 16	2
*** SUB-CATCHMENT 17 AGWO GOES TO SOUND			
PERLND 16	0.90	RCHRES 17	6
PERLND 26	16.31	RCHRES 17	6
PERLND 34	34.82	RCHRES 17	6
PERLND 44	82.11	RCHRES 17	6
PERLND 54	2.19	RCHRES 17	6
IMPLND 14	10.49	RCHRES 17	2
*** SUB-CATCHMENT MC-1			
PERLND 26	0.17	RCHRES 52	1
PERLND 44	8.21	RCHRES 52	1
PERLND 54	0.27	RCHRES 52	1
IMPLND 14	0.09	RCHRES 52	2
*** SUB-CATCHMENT MC-2			
PERLND 16	0.08	RCHRES 53	1
PERLND 26	0.64	RCHRES 53	1
PERLND 34	6.72	RCHRES 53	1
PERLND 44	10.43	RCHRES 53	1
PERLND 54	15.25	RCHRES 53	1
IMPLND 14	0.27	RCHRES 53	2
*** SUB-CATCHMENT MC-3			
PERLND 34	5.44	RCHRES 54	1
PERLND 44	5.03	RCHRES 54	1
PERLND 54	2.28	RCHRES 54	1
IMPLND 14	0.11	RCHRES 54	2
*** SUB-CATCHMENT MC-4			
PERLND 44	17.32	RCHRES 135	1

PERLND	54	14.41	RCHRES	135	1
IMPLND	14	1.77	RCHRES	135	2
*** SUB-CATCHMENT MC-5					
PERLND	26	13.49	RCHRES	35	1
PERLND	44	31.06	RCHRES	35	1
PERLND	54	5.95	RCHRES	35	1
IMPLND	14	2.50	RCHRES	35	2
*** SUB-CATCHMENT MC-6					
PERLND	44	17.75	RCHRES	35	1
PERLND	54	6.54	RCHRES	35	1
IMPLND	14	0.95	RCHRES	35	2
*** SUB-CATCHMENT MC-6B					
PERLND	26	34.94	RCHRES	35	1
PERLND	34	7.81	RCHRES	35	1
PERLND	44	52.91	RCHRES	35	1
PERLND	54	4.61	RCHRES	35	1
IMPLND	14	3.14	RCHRES	35	2
*** SUB-CATCHMENT MC-7					
PERLND	26	12.66	RCHRES	16	1
PERLND	44	33.53	RCHRES	16	1
PERLND	54	4.16	RCHRES	16	1
IMPLND	14	3.88	RCHRES	16	2
*** SUB-CATCHMENT MC-7B					
PERLND	26	36.16	RCHRES	16	1
PERLND	44	8.46	RCHRES	16	1
PERLND	54	1.92	RCHRES	16	1
IMPLND	14	2.12	RCHRES	16	2
***a11 sdn basin agwo goes to 35					
*** SUB-CATCHMENT SDN-1					
PERLND	26	3.23	RCHRES	52	6
PERLND	44	2.11	RCHRES	52	6
PERLND	54	0.20	RCHRES	52	6
PERLND	26	3.23	RCHRES	135	7
PERLND	44	2.11	RCHRES	135	7
PERLND	54	0.20	RCHRES	135	7
IMPLND	14	8.29	RCHRES	52	2
*** SUB-CATCHMENT SDN-1-LWR					
PERLND	44	4.97	RCHRES	52	6
PERLND	54	0.07	RCHRES	52	6
PERLND	44	4.97	RCHRES	135	7
PERLND	54	0.07	RCHRES	135	7
IMPLND	14	0.38	RCHRES	52	2
*** SUB-CATCHMENT SDN-1-OFF					
PERLND	26	29.12	RCHRES	52	6
PERLND	44	3.62	RCHRES	52	6
PERLND	54	1.67	RCHRES	52	6
PERLND	26	29.12	RCHRES	135	7
PERLND	44	3.62	RCHRES	135	7
PERLND	54	1.67	RCHRES	135	7
IMPLND	14	11.50	RCHRES	52	2
*** SUB-CATCHMENT SDN-2					
PERLND	26	10.41	RCHRES	52	6
PERLND	44	3.04	RCHRES	52	6
PERLND	26	10.41	RCHRES	135	7
PERLND	44	3.04	RCHRES	135	7
IMPLND	14	33.22	RCHRES	52	2
*** SUB-CATCHMENT SDN-2X					
PERLND	26	1.37	RCHRES	52	6
PERLND	44	5.84	RCHRES	52	6

PERLND	26	1.37	RCHRES	135	7
PERLND	44	5.84	RCHRES	135	7
IMPLND	14	0.28	RCHRES	52	2

*** SUB-CATCHMENT SDN-3

PERLND	26	49.79	RCHRES	54	6
PERLND	26	49.79	RCHRES	135	7
IMPLND	14	15.82	RCHRES	54	2

*** SUB-CATCHMENT SDN-3X

PERLND	16	0.65	RCHRES	54	6
PERLND	26	5.17	RCHRES	54	6
PERLND	34	13.64	RCHRES	54	6
PERLND	44	5.34	RCHRES	54	6
PERLND	54	0.57	RCHRES	54	6
PERLND	16	0.65	RCHRES	135	7
PERLND	26	5.17	RCHRES	135	7
PERLND	34	13.64	RCHRES	135	7
PERLND	44	5.34	RCHRES	135	7
PERLND	54	0.57	RCHRES	135	7

*** SUB-CATCHMENT SDN-4

PERLND	26	24.43	RCHRES	52	6
PERLND	44	3.19	RCHRES	52	6
PERLND	26	24.43	RCHRES	135	7
PERLND	44	3.19	RCHRES	135	7
IMPLND	14	2.61	RCHRES	52	2

*** SUB-CATCHMENT SDN-4X

PERLND	26	1.57	RCHRES	52	6
PERLND	34	1.16	RCHRES	52	6
PERLND	44	10.01	RCHRES	52	6
PERLND	26	1.57	RCHRES	135	7
PERLND	34	1.16	RCHRES	135	7
PERLND	44	10.01	RCHRES	135	7

***new areas added 11/19/01

***SDE4					
PERLND	26	0.04	RCHRES	35	7
***sdw1b1					
PERLND	26	10.14	RCHRES	35	7
***sdw2					
PERLND	26	4.06	RCHRES	35	7

***ROUTING FOR MILLER CREEK

*** M1 TO M2 TO M3 TO STORAGE 50. M4 TO M5 TO STORAGE 50

RCHRES	1		RCHRES	2	4
RCHRES	23		RCHRES	24	4
RCHRES	24		RCHRES	3	3
RCHRES	2		RCHRES	3	3
RCHRES	3		RCHRES	33	3
RCHRES	33		RCHRES	50	3
RCHRES	4		RCHRES	5	4
RCHRES	5		RCHRES	50	3
*** NEW STREAM REACH 52 TO LAKE REBA 53 TO			RDF	54	
RCHRES	52		RCHRES	53	3
RCHRES	53		RCHRES	54	3
RCHRES	50		RCHRES	54	3
*** RDF 54 TO 35					
RCHRES	54		RCHRES	135	3
RCHRES	34		RCHRES	135	4
RCHRES	34		RCHRES	135	5
RCHRES	135		RCHRES	35	3

1	0	1	0	0	4	5	0	0	0	0	0	0	0	0	2	2	2	2	2
2	0	0	0	0	4	0	0	0	0	0	0	0	0	0	2	2	2	2	2
3	0	0	0	0	4	0	0	0	0	0	0	0	0	0	2	2	2	2	2
4	0	0	1	0	0	4	5	0	0	0	0	0	0	0	2	2	2	2	2
5	12	0	0	0	0	4	0	0	0	0	0	0	0	0	2	2	2	2	2
13	0	0	1	0	0	4	5	0	0	0	0	0	0	0	2	2	2	2	2
14	22	0	0	0	0	4	0	0	0	0	0	0	0	0	2	2	2	2	2
23	0	0	1	0	0	4	5	0	0	0	0	0	0	0	2	2	2	2	2
24	33	0	0	0	0	4	0	0	0	0	0	0	0	0	2	2	2	2	2
34	0	0	1	0	0	4	5	0	0	0	0	0	0	0	2	2	2	2	2
35	999	0	0	0	0	4	0	0	0	0	0	0	0	0	2	2	2	2	2

END HYDR-PARM1
HYDR-PARM2

RCHRES		FTABNO	LEN	DELTH	STCOR	KS	DB50	***
#	- #							***
1		1	0.010			0.3		
2		2	0.776			0.3		
3		3	0.980			0.3		
4		4	0.010			0.3		
5		5	0.380			0.3		
10		10	0.380			0.3		
11		11	0.010			0.3		
12		12	1.000			0.3		
13		13	0.015			0.3		
14		14	0.450			0.3		
15		15	0.735			0.3		
16		16	0.587			0.3		
17		17	0.379			0.3		
23		23	0.379		300.0	0.3		
24		24	0.379			0.3		
33		33	0.200			0.3		
34		34	0.852			0.3		
35		35	0.663			0.3		
38		38	0.010			0.3		
50		50	0.010			0.3		
52		52	0.010			0.3		
53		53	0.010			0.3		
54		54	0.010			0.3		
135		135	0.350			0.3		

END HYDR-PARM2
HYDR-INIT

RCHRES		VOL	Initial value of COLIND		Initial value of OUTDGT		***
#	- #	*** ac-ft	for each possible exit		for each possible exit		***
1		2.0	4.0	5.0			
2		0.0	4.0				
3		0.0	4.0	5.0			
4		2.0	4.0				
5		0.0	4.0				
10		0.0	4.0				
11		0.0	4.0				
12		0.0	4.0				
13		10.0	4.0	5.0			
14		0.0	4.0				
15		0.0	4.0				
16		0.0	4.0				
17		0.0	4.0				
23		6.0	4.0	5.0			
24		0.0	4.0				
33		0.0	4.0				
34		9.0	4.0	5.0			

```

35      0.1      4.0
38      0.1      4.0
50      0.0      4.0
52      0.0      4.0
53      0.1      4.0
54      2.25     4.0
135     0.00     4.0

```

END HYDR-INIT
END RCHRES

FTABLES
***UPPER BASIN

```

FTABLE      1
ROWS COLS  ***
 11      5
  DEPTH      AREA      VOLUME      OUTFLOW      OUTFLOW2***
  0.00      3.00      0.00      0.00      0.00
  2.50      3.00      7.50      0.00      0.11
  3.00      3.00      9.00      1.80      0.11
  3.50      3.30      10.58     5.00      0.11
  4.00      3.60      12.30     10.90     0.11
  4.50      3.90      14.18     17.50     0.11
  5.00      4.10      16.18     26.20     0.11
  5.50      4.30      18.28     32.50     0.11
  6.00      4.50      20.48     35.90     0.11
  7.00      5.00      25.23     38.10     0.11
  8.00      5.50      30.48     46.40     0.11
END FTABLE  1

```

```

FTABLE      2
ROWS COLS  ***
 9      4
  DEPTH      AREA      VOLUME      OUTFLOW      ***
  0.00      0.0000     0.0000     0.00
  0.100     0.2571     0.0129     0.16
  0.500     0.3873     0.1417     6.53
  1.000     0.5501     0.3761     25.95
  1.500     0.7128     0.6918     59.86
  2.000     0.8756     1.0889     110.67
  3.000     1.2011     2.1273     272.24
  3.500     1.3639     2.7685     387.38
  4.000     1.5266     3.4912     528.19
END FTABLE  2

```

```

FTABLE      3
ROWS COLS  ***
12      4
  DEPTH      AREA      VOLUME      OUTFLOW      ***
  0.000     0.0000     0.0000     0.00
  0.100     0.9669     0.0483     0.13
  0.500     1.0637     0.4545     4.92
  1.000     1.1846     1.0165     17.12
  1.500     1.3055     1.6390     34.92
  2.000     1.4264     2.3220     57.95
  2.500     1.5473     3.0654     86.14
  3.000     1.6682     3.8693     119.53
  3.500     1.7891     4.7336     158.24
  4.000     1.9100     5.6584     202.41
  4.500     2.0294     6.6310     251.52
  5.000     2.1488     7.6624     306.28
END FTABLE  3

```

FTABLE 4
 ROWS COLS ***
 7 5

DEPTH	AREA	VOLUME	OUTFLOW	OUTFLOW2***
0.00	3.00	0.00	0.00	0.00
2.50	4.50	9.38	0.00	0.11
3.00	6.00	12.00	6.00	0.11
4.00	10.00	20.00	13.00	0.11
5.00	15.00	32.50	20.00	0.11
6.00	20.00	50.00	26.00	0.11
7.00	25.00	72.50	168.00	0.11

END FTABLE 4

FTABLE 5
 ROWS COLS ***
 10 4

DEPTH	AREA	VOLUME	OUTFLOW	***
0.000	0.0000	0.0000	0.00	
0.100	0.1010	0.0051	0.03	
0.500	0.1754	0.0603	1.46	
1.000	0.2684	0.1713	6.16	
1.500	0.3614	0.3288	14.89	
2.000	0.4544	0.5327	28.48	
2.500	0.5474	0.7832	47.70	
3.000	0.6404	1.0801	73.29	
3.500	0.7334	1.4236	105.94	
4.000	0.8264	1.8136	146.33	

END FTABLE 5

FTABLE 10
 ROWS COLS ***
 9 4

DEPTH	AREA	VOLUME	OUTFLOW	***
0.000	0.0000	0.0000	0.00	
0.100	0.1010	0.0051	0.06	
0.500	0.1660	0.0585	2.27	
1.000	0.2472	0.1618	9.32	
1.500	0.3285	0.3057	22.08	
2.000	0.4097	0.4902	41.66	
2.500	0.4909	0.7154	69.09	
3.000	0.5722	0.9811	105.37	
4.000	0.6887	1.6116	209.70	

END FTABLE 10

POST AMBAUM DETENTION ***
 FTABLE 11
 ROWS COLS ***
 11 4

DEPTH	AREA	VOLUME	OUTFLOW	***
0.000	0.0000	0.0000	0.00	
1.000	0.1000	0.2300	3.90	
2.000	0.2000	0.6000	6.30	
3.000	0.3000	0.9700	8.10	
4.000	0.4000	1.3400	11.10	
5.000	0.5000	1.8200	16.00	
6.000	0.6000	2.2700	19.10	
7.000	0.7000	2.8300	21.60	
8.000	0.8000	3.3700	30.80	
9.000	0.9000	4.0000	38.10	
10.000	1.0000	4.6500	74.10	
10.500	1.1000	5.2000	133.00	
11.000	1.1500	5.3000	500.00	

END FTABLE 11

FTABLE 12
ROWS COLS ***
6 4

DEPTH	AREA	VOLUME	OUTFLOW	***
0.000	0.0000	0.0000	0.00	
0.100	0.6327	0.0316	0.15	
0.500	0.7960	0.3174	5.87	
1.000	1.0002	0.7664	21.53	
1.500	1.2043	1.3176	46.43	
2.000	1.4085	1.9708	81.20	
3.000	1.8168	3.5834	183.79	
4.000	2.2251	5.6044	336.22	
5.000	2.6335	8.0337	545.30	
6.000	3.0418	10.8713	817.51	

END FTABLE 12

FTABLE 13
ROWS COLS ***
7 5

DEPTH	AREA	VOLUME	OUTFLOW	OUTFLOW2***
0.000	40.000	0.0000	0.00	0.00
1.000	41.400	40.000	0.00	0.11
1.500	42.000	60.000	10.00	0.11
2.000	42.700	80.000	16.00	0.11
2.500	43.300	100.00	20.00	0.11
3.000	44.000	120.00	28.00	0.11
5.000	45.000	210.00	45.00	0.11

END FTABLE 13

FTABLE 14
ROWS COLS ***
6 4

DEPTH	AREA	VOLUME	OUTFLOW	***
0.000	0.0000	0.0000	0.00	
0.100	0.3361	0.0168	0.24	
0.500	0.3809	0.1602	9.04	
1.000	0.4370	0.3647	31.61	
1.500	0.4930	0.5972	65.00	
2.000	0.5491	0.8577	108.85	
2.500	0.6051	1.1462	163.33	
3.000	0.6612	1.4628	228.78	

END FTABLE 14

FTABLE 15
ROWS COLS ***
4 4

DEPTH	AREA	VOLUME	OUTFLOW	***
0.00	0.10	0.00	0.00	
1.00	1.00	0.55	91.00	
2.00	1.10	1.60	268.00	
3.00	1.20	2.75	493.00	

END FTABLE 15

FTABLE 16
ROWS COLS ***
4 4

DEPTH	AREA	VOLUME	OUTFLOW	***
0.00	0.10	0.00	0.00	
1.00	1.00	0.55	74.00	
2.00	1.10	1.60	219.00	
3.00	1.20	2.75	403.00	

END FTABLE 16

FTABLE 17
 ROWS COLS ***
 5 4

DEPTH	AREA	VOLUME	OUTFLOW	***
0.00	0.10	0.00	0.00	
1.00	1.00	0.55	59.00	
2.00	1.10	1.60	173.00	
3.00	1.20	2.75	318.00	
4.00	1.30	4.00	484.00	

END FTABLE 17

FTABLE 23
 ROWS COLS *** HERMES
 9 5

DEPTH	AREA	VOLUME	OUTFLOW	OUTFLOW	***
0.00	0.00	0.00	0.00	0.00	0.00
5.00	0.50	1.91	0.00	0.00	305.00
11.00	0.79	5.79	0.00	0.00	311.00
15.00	1.13	9.64	0.50	0.01	315.00
19.00	1.72	15.34	0.50	0.05	319.00
29.00	2.86	38.25	0.50	0.10	329.00
39.00	4.40	74.55	0.50	0.20	339.00
50.00	6.22	132.98	0.50	0.30	350.00
60.00	10.00	1212.98	0.50	0.40	360.00

END FTABLE 23

FTABLE 24
 ROWS COLS ***
 9 4

DEPTH	AREA	VOLUME	OUTFLOW	***
0.000	0.0000	0.0000	0.00	
0.100	0.2571	0.0129	0.16	
0.500	0.3873	0.1417	6.53	
1.000	0.5501	0.3761	25.95	
1.500	0.7128	0.6918	59.86	
2.000	0.8756	1.0889	110.67	
3.000	1.2011	2.1273	272.24	
3.500	1.3639	2.7685	387.38	
4.000	1.5266	3.4912	528.19	

END FTABLE 24

FTABLE 33
 ROWS COLS ***
 11 4

DEPTH	AREA	VOLUME	OUTFLOW	***
0.00	1.00	0.00	0.00	
0.50	1.20	0.55	2.00	
1.00	1.40	1.20	6.00	
1.50	1.60	1.95	9.00	
2.00	1.80	2.80	13.00	
2.50	2.00	3.75	16.50	
3.00	2.20	4.80	20.00	
3.50	2.40	5.95	23.00	
4.00	2.60	7.20	26.00	
5.00	2.80	9.90	104.00	
6.00	3.00	12.80	246.00	

END FTABLE 33

FTABLE 34
 ROWS COLS *** REVISED 11/19/97 BASED ON HEC-RAS MODEL
 6 5

DEPTH	AREA	VOLUME	OUTFLOW	OUTFLOW2***
0.00	3.00	0.00	0.00	0.00
3.00	3.05	9.08	0.00	0.11
4.00	3.10	12.15	0.00	0.11
5.00	3.15	15.28	0.00	0.11
6.00	3.20	18.45	72.0	0.11
7.00	3.25	21.68	225.0	0.11

END FTABLE 34

FTABLE 35
ROWS COLS *** REVISED 11/19/97 BASED ON HECRAS MODEL

DEPTH	AREA	VOLUME	OUTFLOW	***
0.00	0.10	0.00	0.00	
1.00	1.10	0.60	38.00	
2.00	1.20	1.75	108.00	
3.00	1.30	3.00	194.00	
4.00	1.40	4.35	290.00	

END FTABLE 35

FTABLE 38
ROWS COLS ***

DEPTH	AREA	VOLUME	OUTFLOW	***
0.000	0.0000	0.0000	0.00	
1.000	0.4000	0.4000	2.00	
1.500	0.5000	1.0000	4.00	
2.000	0.9000	1.3000	11.00	
2.500	1.3000	1.6000	15.00	
3.000	1.6000	2.0000	18.00	
3.500	1.9000	2.5000	20.80	

END FTABLE 38

FTABLE 45
ROWS COLS ***
NORTH EMPLOYEE PARKING LOT VAULT (AS-BUILT)***

DEPTH	AREA	VOLUME	OUTFLOW	***
0.000	0.2200	0.0000	0.00	
2.000	0.2200	0.4500	1.20	
4.000	0.2200	0.9000	1.70	
6.000	0.2200	1.3400	2.10	
8.000	0.2200	1.7900	2.40	
10.000	0.2200	2.2400	2.70	
12.240	0.2200	2.7400	3.00	
14.000	0.2200	3.1400	6.90	
15.440	0.2200	3.4600	8.30	
16.000	0.2200	3.5800	10.30	
18.000	0.2200	4.0300	13.60	
20.000	0.2200	4.4800	30.79	

END FTABLE 45

FTABLE 50
ROWS COLS ***

DEPTH	AREA	VOLUME	OUTFLOW	***
0.00	1.00	0.00	0.00	
0.50	1.10	0.53	5.00	
1.00	1.20	1.10	15.00	
1.50	1.30	1.73	25.00	
2.00	1.40	2.40	35.00	
2.50	1.50	3.13	52.00	
3.00	1.60	3.90	70.00	

Page 16

3.50	1.70	4.73	87.00
4.00	1.80	5.60	105.00
6.00	1.90	9.30	165.00

END FTABLE 50

FTABLE 52
ROWS COLS ***
6 4

DEPTH	AREA	VOLUME	OUTFLOW	***
0.000	0.0000	0.0000	0.00	
0.100	0.3680	0.0184	0.25	
0.500	0.3717	0.1664	9.39	
1.000	0.3763	0.3534	31.06	
2.000	0.3819	0.7325	94.37	
3.000	0.3874	1.1171	174.33	

END FTABLE 52

FTABLE 53
OLD LAKE REBA ***
MAX DEPTH = 4.9 FEET ***
30" CMP, 40 CFS DISCHARGE AT MAX DEPTH ***
ROWS COLS ***
7 4

DEPTH	AREA	VOLUME	OUTFLOW	***
0.000	2.4000	0.0000	0.00	
1.000	2.5800	2.5000	18.00	
2.000	2.9400	5.3000	26.00	
3.000	3.4100	8.4000	31.00	
4.000	3.8800	12.100	36.00	
4.900	4.3000	15.800	40.00	
6.000	4.3000	15.810	500.00	

END FTABLE 53

FTABLE 54
EXISTING MILLER CREEK DETENTION FACILITY*** REVISED STORAGE/Q DATA
GATE SETTING: 2.0 FEET***
ROWS COLS ***
12 4

DEPTH	AREA	VOLUME	OUTFLOW	***
0.000	0.00	0.00	0.00	
1.300	0.01	0.01	10.00	
2.000	0.01	0.02	20.00	
2.900	0.70	0.40	30.00	
4.000	1.50	1.50	40.00	
5.400	3.50	4.90	50.00	
7.000	8.60	13.30	60.00	
8.800	15.60	34.80	70.00	
10.000	19.90	57.30	76.00	
10.500	21.50	68.00	92.00	
11.000	23.10	78.80	179.00	
11.500	24.70	88.60	303.00	

END FTABLE 54

PRE AMBAUM DETENTION ***
FTABLE 111
ROWS COLS ***
12 4

DEPTH	AREA	VOLUME	OUTFLOW	***
0.000	0.0000	0.0000	0.00	
0.500	0.2160	0.0750	5.30	
1.000	0.2730	0.1990	21.10	
1.500	0.2890	0.3410	43.90	
2.000	0.2900	0.4830	68.80	

2.500	0.2910	0.6070	89.10
3.000	0.2950	0.6820	90.00
3.500	0.3000	2.1000	100.00
4.000	0.3050	2.5000	105.00
4.500	0.3100	3.0000	110.00
5.000	0.3200	3.5000	120.00
5.500	0.3300	4.0000	130.00

END FTABLE111

FTABLE 135
ROWS COLS *** VACA FARM

6	4				
DEPTH	AREA	VOLUME	OUTFLOW	***	
0.00	0.10	0.00	0.00		
1.00	0.10	0.10	4.00		
2.00	0.11	0.21	8.00		
2.50	1.00	0.48	13.00		
3.50	6.50	4.23	86.00		
4.50	13.00	13.98	235.00		

END FTABLE135

END FTABLES

```

MASS-LINK
<Volume> <-Grp> <-Member-><--Mult--> <Target> <-Grp> <-Member->***
<Name> <Name> # #<-factor-> <Name> <Name> # #***
  MASS-LINK 1
  conversion from acre-inches to acre-ft (1/12) ***
  PERLND PWATER PERO 0.0833333 RCHRES INFLOW IVOL
  END MASS-LINK 1

  MASS-LINK 2
  IMPLND IWATER SURO 0.0833333 RCHRES INFLOW IVOL
  END MASS-LINK 2

  MASS-LINK 3
  RCHRES ROFLOW RCHRES INFLOW
  END MASS-LINK 3

  MASS-LINK 4
  RCHRES OFLOW OVOL 1 RCHRES INFLOW IVOL
  END MASS-LINK 4

  MASS-LINK 5
  RCHRES OFLOW OVOL 2 RCHRES INFLOW IVOL
  END MASS-LINK 5

  MASS-LINK 6
  PERLND PWATER SURO 0.0833333 RCHRES INFLOW IVOL
  PERLND PWATER IFWO 0.0833333 RCHRES INFLOW IVOL
  END MASS-LINK 6

  MASS-LINK 7
  PERLND PWATER AGWO 0.0833333 RCHRES INFLOW IVOL
  END MASS-LINK 7

  MASS-LINK 8
  PERLND PWATER PERO 0.0833333 COPY INPUT MEAN
  END MASS-LINK 8
  
```

```

      MASS-LINK      12
PERLND  PWATER AGWO  0.0833333  COPY      INPUT  MEAN
      END MASS-LINK  12

      MASS-LINK      9
IMPLND  IWATER SURO  0.0833333  COPY      INPUT  MEAN
      END MASS-LINK  9

      MASS-LINK      10
COPY    OUTPUT MEAN
      END MASS-LINK  10
                                RCHRES      INFLOW IVOL

      END MASS-LINK
      END RUN
```

2006 CONDITIONS

AR 020313

END NETWORK

RCHRES

GEN-INFO

#	RCHRES	Name	Nexits	Unit systems		Printer		
				User	T-series	Engl	Metr	LKFG
1		Arbor Lake M 1	2	1	1	62	0	0
2		Arbor Ck -03710 M 2	1	1	1	62	0	0
3		Arbor Ck M 3	1	1	1	62	0	0
4		Tub Lake M 4	2	1	1	62	0	0
5		Miller Ck SR518 M5	1	1	1	62	0	0
10		Trib (0371G) M 10	1	1	1	62	0	0
11		M11 Ambaum Detention	1	1	1	62	0	0
12		Trib(0354) M 12	1	1	1	62	0	0
13		Burien Lake M 13	2	1	1	62	0	0
14		Trib (0353) M 14	1	1	1	62	0	0
15		M/S U/S OF 17	1	1	1	62	0	0
16		U/S OF 15 M/S	1	1	1	62	0	0
17		GAGE	1	1	1	62	0	0
23		BASIN M23	2	1	1	62	0	0
24		BASIN M24	1	1	1	62	0	0
33		detention m3	1	1	1	62	0	0
34		LORA LAKE	2	1	1	62	0	0
35		D/S OF VACA FARM	1	1	1	62	0	0
37		sdn3ai vault	1	1	1	62	0	0
38		MC basins	1	1	1	62	0	0
***	39	SDN3A/SDW1A POC		1	1	62	0	0
43		sdn3 pond	1	1	1	62	0	0
***	44	sdn4 pond		1	1	62	0	0
***	45	nep1 poc		1	1	62	0	0
46		cargo pond	1	1	1	62	0	0
47		sdw1a infiltration	2	1	1	62	0	0
50		sr 518	1	1	1	62	0	0
51		SDN2X+SDN4X	1	1	1	62	0	0
52		U/S OF LAKE REBA	1	1	1	62	0	0
53		Reba outflow	1	1	1	62	0	0
54		Miller RDF outflow	1	1	1	62	0	0
57		sdw1b pond	1	1	1	62	0	0
135		VACA FARMS	1	1	1	62	0	0
147		sdw1a vault	2	1	1	62	0	0
237		sdn3ao-pond c	1	1	1	62	0	0
240		iws-ncps	2	1	1	62	0	0
242		iws-nsmps	2	1	1	62	0	0
247		sdw1a pond g	2	1	1	62	0	0
257		sdw1b infiltration	2	1	1	62	0	0
451		nep1 VAULT	1	1	1	62	0	0
452		nep1 VAULT	1	1	1	62	0	0
552		SDN1 POC	1	1	1	62	0	0
570		SDW1B flow splitter	2	1	1	62	0	0
***	645	nep1 POC		1	1	62	0	0

END GEN-INFO

ACTIVITY

RCHRES	***** Active Sections *****
# - #	HYFG ADFG CNFG HTFG SDFG GQFG OXFG NUGF PKFG PHFG
1 999	1 0 0 0 0 0 0 0 0 0 0

END ACTIVITY

PRINT-INFO

RCHRES	***** Printout Flags *****
# - #	HYDR ADCA CONS HEAT SED GQL OXRX NUTR PLNK PHCB PIVL PYR
1 999	5 0 0 0 0 0 0 0 0 0 0 0 0 1 9

END PRINT-INFO

HYDR-PARM1

RCHRES # - #	Flags for each HYDR Section				ODFVFG for each					ODGTFG for each				FUNCT for each			
	VC	A1	A2	A3	possible		exit			possible		exit		possible		exit	
*	*	*	*	*	*	*	*	*	*	*	*	*	*	*	*	*	*
1	0	1	0	0	4	5	0	0	0	0	0	0	0	2	2	2	2
2	0	0	0	0	4	0	0	0	0	0	0	0	0	2	2	2	2
3	0	0	0	0	4	0	0	0	0	0	0	0	0	2	2	2	2
4	0	1	0	0	4	5	0	0	0	0	0	0	0	2	2	2	2
5	12	0	0	0	4	0	0	0	0	0	0	0	0	2	2	2	2
13	0	1	0	0	4	5	0	0	0	0	0	0	0	2	2	2	2
14	22	0	0	0	4	0	0	0	0	0	0	0	0	2	2	2	2
23	0	1	0	0	4	5	0	0	0	0	0	0	0	2	2	2	2
24	33	0	0	0	4	0	0	0	0	0	0	0	0	2	2	2	2
34	0	1	0	0	4	5	0	0	0	0	0	0	0	2	2	2	2
35	46	0	1	0	4	0	0	0	0	0	0	0	0	2	2	2	2
47	0	1	0	0	4	5	0	0	0	0	0	0	0	2	2	2	2
50	54	0	1	0	4	0	0	0	0	0	0	0	0	2	2	2	2
57	0	1	0	0	4	0	0	0	0	0	0	0	0	2	2	2	2
100	135	0	1	1	4	0	0	0	0	0	0	0	0	2	2	2	2
147	0	1	1	0	4	0	0	0	0	0	0	0	0	2	2	2	2
237	0	1	1	0	4	0	0	0	0	0	0	0	0	2	2	2	2
240	300	0	1	1	4	5	0	0	0	0	0	0	0	2	2	2	2
301	552	0	1	0	4	0	0	0	0	0	0	0	0	2	2	2	2
570	0	1	1	0	4	5	0	0	0	0	0	0	0	2	2	2	2

HYDR-PARM2

RCHRES # - #	FTABNO	LEN	DELTH	STCOR	KS	DB50	***
1	1	0.010			0.3		***
2	2	0.776			0.3		***
3	3	0.980			0.3		***
4	4	0.010			0.3		***
5	5	0.380			0.3		***
10	10	0.380			0.3		***
11	11	0.010			0.3		***
12	12	1.000			0.3		***
13	13	0.015			0.3		***
14	14	0.450			0.3		***
15	15	0.735			0.3		***
16	16	0.587			0.3		***
17	17	0.379			0.3		***
23	23	0.379		0.0	0.3		***
24	24	0.379			0.3		***
33	33	0.200			0.3		***
34	34	0.852			0.3		***
35	35	0.663			0.3		***
37	37	0.010			0.3		***
38	38	0.010		0.0	0.3		***
43	43	0.010			0.3		***
46	46	0.010			0.3		***
47	47	0.010			0.3		***
50	50	0.010		0.0	0.3		***
51	51	0.010			0.3		***
52	52	0.010			0.3		***
53	53	0.010			0.3		***
54	54	0.010			0.3		***
57	57	0.010		0.0	0.3		***
135	135	0.350		0.0	0.3		***

147	147	0.010	0.0	0.3
237	237	0.010	0.0	0.3
240	240	0.010		0.3
242	242	0.010		0.3
247	247	0.010	0.0	0.3
257	257	0.010	0.0	0.3
451	451	0.010	0.0	0.3
452	452	0.010	0.0	0.3
552	552	0.010	0.0	0.3
570	570	0.010	0.0	0.3

END HYDR-PARM2

HYDR-INIT

RCHRES Initial conditions for each HYDR section ***
 # - # *** VOL Initial value of COLIND Initial value of OUTDGT ***
 *** ac-ft for each possible exit for each possible exit

1	2.0	4.0	5.0
2	0.0	4.0	
3	0.0	4.0	
4	2.0	4.0	5.0
5	0.0	4.0	
10	0.0	4.0	
11	0.0	4.0	
12	0.0	4.0	
13	10.0	4.0	5.0
14	0.0	4.0	
15	0.0	4.0	
16	0.0	4.0	
17	0.0	4.0	
23	6.0	4.0	5.0
24	0.0	4.0	
33	0.0	4.0	
34	9.0	4.0	5.0
35	0.1	4.0	
37	0.0	4.0	
38	0.1	4.0	
43	0.0	4.0	
46	0.0	4.0	
47	0.0	4.0	5.0
50	0.0	4.0	
51	0.0	4.0	
52	0.0	4.0	
53	0.1	4.0	
54	2.25	4.0	
57	0.0	4.0	
237	0.00	4.0	
147	1.00	4.0	5.0
135	0.00	4.0	
240	0.0	4.0	5.0
242	0.0	4.0	5.0
247	0.0	4.0	5.0
257	0.0	4.0	5.0
451	0.0	4.0	
452	0.0	4.0	
552	0.0	4.0	
570	0.0	4.0	5.0

END HYDR-INIT
 END RCHRES

FTABLES
 ***UPPER BASIN

***=====

FTABLE 1

*** REVISED 8/16/00 ADDED 2ND OUTFLOW

ROWS COLS ***

11 5

DEPTH	AREA	VOLUME	OUTFLOW	OUTFLOW2***
0.00	3.00	0.00	0.00	0.00
2.50	3.00	7.50	0.00	0.11
3.00	3.00	9.00	1.80	0.11
3.50	3.30	10.58	5.00	0.11
4.00	3.60	12.30	10.90	0.11
4.50	3.90	14.18	17.50	0.11
5.00	4.10	16.18	26.20	0.11
5.50	4.30	18.28	32.50	0.11
6.00	4.50	20.48	35.90	0.11
7.00	5.00	25.23	38.10	0.11
8.00	5.50	30.48	46.40	0.11

END FTABLE 1

FTABLE 2

ROWS COLS ***

9 4

DEPTH	AREA	VOLUME	OUTFLOW	***
0.000	0.0000	0.0000	0.00	
0.100	0.2571	0.0129	0.16	
0.500	0.3873	0.1417	6.53	
1.000	0.5501	0.3761	25.95	
1.500	0.7128	0.6918	59.86	
2.000	0.8756	1.0889	110.67	
3.000	1.2011	2.1273	272.24	
3.500	1.3639	2.7685	387.38	
4.000	1.5266	3.4912	528.19	

END FTABLE 2

FTABLE 3

ROWS COLS ***

12 4

DEPTH	AREA	VOLUME	OUTFLOW	***
0.000	0.0000	0.0000	0.00	
0.100	0.9669	0.0483	0.13	
0.500	1.0637	0.4545	4.92	
1.000	1.1846	1.0165	17.12	
1.500	1.3055	1.6390	34.92	
2.000	1.4264	2.3220	57.95	
2.500	1.5473	3.0654	86.14	
3.000	1.6682	3.8693	119.53	
3.500	1.7891	4.7336	158.24	
4.000	1.9100	5.6584	202.41	
4.500	2.0294	6.6310	251.52	
5.000	2.1488	7.6624	306.28	

END FTABLE 3

FTABLE 4

*** REVISED 8/16/00 ADDED 2ND OUTFLOW

ROWS COLS ***

7 5

DEPTH	AREA	VOLUME	OUTFLOW	OUTFLOW2***
0.00	3.00	0.00	0.00	0.00
2.50	4.50	9.38	0.00	0.11
3.00	6.00	12.00	6.00	0.11
4.00	10.00	20.00	13.00	0.11
5.00	15.00	32.50	20.00	0.11

Page 18

6.00	20.00	50.00	26.00	0.11
7.00	25.00	72.50	168.00	0.11

END FTABLE 4

FTABLE 5
 ROWS COLS ***
 10 4

DEPTH	AREA	VOLUME	OUTFLOW	***
0.000	0.0000	0.0000	0.00	
0.100	0.1010	0.0051	0.03	
0.500	0.1754	0.0603	1.46	
1.000	0.2684	0.1713	6.16	
1.500	0.3614	0.3288	14.89	
2.000	0.4544	0.5327	28.48	
2.500	0.5474	0.7832	47.70	
3.000	0.6404	1.0801	73.29	
3.500	0.7334	1.4236	105.94	
4.000	0.8264	1.8136	146.33	

END FTABLE 5

FTABLE 10
 ROWS COLS ***
 9 4

DEPTH	AREA	VOLUME	OUTFLOW	***
0.000	0.0000	0.0000	0.00	
0.100	0.1010	0.0051	0.06	
0.500	0.1660	0.0585	2.27	
1.000	0.2472	0.1618	9.32	
1.500	0.3285	0.3057	22.08	
2.000	0.4097	0.4902	41.66	
2.500	0.4909	0.7154	69.09	
3.000	0.5722	0.9811	105.37	
4.000	0.6887	1.6116	209.70	

END FTABLE 10

POST AMBAUM DETENTION ***
 FTABLE 11
 ROWS COLS ***
 12 4

DEPTH	AREA	VOLUME	OUTFLOW	***
0.000	0.0000	0.0000	0.00	
1.000	0.1000	0.2300	3.90	
2.000	0.2000	0.6000	6.30	
3.000	0.3000	0.9700	8.10	
4.000	0.4000	1.3400	11.10	
5.000	0.5000	1.8200	16.00	
6.000	0.6000	2.2700	19.10	
7.000	0.7000	2.8300	21.60	
8.000	0.8000	3.3700	30.80	
9.000	0.9000	4.0000	38.10	
10.000	1.0000	4.6500	74.10	
10.500	1.1000	5.2000	133.00	
11.000	1.1500	6.0000	500.00	
11.500	1.3000	11.000	1300.00	

END FTABLE 11

FTABLE 12
 ROWS COLS ***
 6 4

DEPTH	AREA	VOLUME	OUTFLOW	***
0.000	0.0000	0.0000	0.00	
0.100	0.6327	0.0316	0.15	
0.500	0.7960	0.3174	5.87	

1.000	1.0002	0.7664	21.53
1.500	1.2043	1.3176	46.43
2.000	1.4085	1.9708	81.20
3.000	1.8168	3.5834	183.79
4.000	2.2251	5.6044	336.22
5.000	2.6335	8.0337	545.30
6.000	3.0418	10.8713	817.51

END FTABLE 12

FTABLE 13
 *** REVISED 8/16/00 ADDED 2ND OUTFLOW

ROWS COLS ***
 7 5

DEPTH	AREA	VOLUME	OUTFLOW	OUTFLOW2***
0.000	40.000	0.0000	0.00	0.00
1.000	41.400	40.000	0.00	0.11
1.500	42.000	60.000	10.00	0.11
2.000	42.700	80.000	16.00	0.11
2.500	43.300	100.00	20.00	0.11
3.000	44.000	120.00	28.00	0.11
5.000	45.000	210.00	45.00	0.11

END FTABLE 13

FTABLE 14
 ROWS COLS ***
 6 4

DEPTH	AREA	VOLUME	OUTFLOW	***
0.000	0.0000	0.0000	0.00	
0.100	0.3361	0.0168	0.24	
0.500	0.3809	0.1602	9.04	
1.000	0.4370	0.3647	31.61	
1.500	0.4930	0.5972	65.00	
2.000	0.5491	0.8577	108.85	
2.500	0.6051	1.1462	163.33	
3.000	0.6612	1.4628	228.78	

END FTABLE 14

FTABLE 15
 ROWS COLS ***
 4 4

DEPTH	AREA	VOLUME	OUTFLOW	***
0.00	0.10	0.00	0.00	
1.00	1.00	0.55	91.00	
2.00	1.10	1.60	268.00	
3.00	1.20	2.75	493.00	

END FTABLE 15

FTABLE 16
 ROWS COLS ***
 4 4

DEPTH	AREA	VOLUME	OUTFLOW	***
0.00	0.10	0.00	0.00	
1.00	1.00	0.55	74.00	
2.00	1.10	1.60	219.00	
3.00	1.20	2.75	403.00	

END FTABLE 16

FTABLE 17
 ROWS COLS ***
 5 4

DEPTH	AREA	VOLUME	OUTFLOW	***
0.00	0.10	0.00	0.00	
1.00	1.00	0.55	59.00	

2.00	1.10	1.60	173.00
3.00	1.20	2.75	318.00
4.00	1.30	4.00	484.00

END FTABLE 17

FTABLE 23
 ROWS COLS *** HERMES
 9 5

DEPTH	AREA	VOLUME	OUTFLOW	OUTFLOW	***
0.00	0.00	0.00	0.00	0.00	0.00
5.00	0.50	1.91	0.00	0.00	305.00
11.00	0.79	5.79	0.00	0.00	311.00
15.00	1.13	9.64	0.50	0.01	315.00
19.00	1.72	15.34	0.50	0.05	319.00
29.00	2.86	38.25	0.50	0.10	329.00
39.00	4.40	74.55	0.50	0.20	339.00
50.00	6.22	132.98	0.50	0.30	350.00
60.00	10.00	1212.98	0.50	0.40	360.00

END FTABLE 23

FTABLE 24
 ROWS COLS ***
 9 4

DEPTH	AREA	VOLUME	OUTFLOW	***
0.000	0.0000	0.0000	0.00	
0.100	0.2571	0.0129	0.16	
0.500	0.3873	0.1417	6.53	
1.000	0.5501	0.3761	25.95	
1.500	0.7128	0.6918	59.86	
2.000	0.8756	1.0889	110.67	
3.000	1.2011	2.1273	272.24	
3.500	1.3639	2.7685	387.38	
4.000	1.5266	3.4912	528.19	

END FTABLE 24

FTABLE 33
 ROWS COLS ***
 11 4

DEPTH	AREA	VOLUME	OUTFLOW	***
0.00	1.00	0.00	0.00	
0.50	1.20	0.55	2.00	
1.00	1.40	1.20	6.00	
1.50	1.60	1.95	9.00	
2.00	1.80	2.80	13.00	
2.50	2.00	3.75	16.50	
3.00	2.20	4.80	20.00	
3.50	2.40	5.95	23.00	
4.00	2.60	7.20	26.00	
5.00	2.80	9.90	104.00	
6.00	3.00	12.80	246.00	

END FTABLE 33

FTABLE 34
 ROWS COLS *** REVISED 11/19/97 BASED ON HEC-RAS MODEL
 *** REVISED 8/16/00 ADDED 2ND OUTFLOW

DEPTH	AREA	VOLUME	OUTFLOW	OUTFLOW2***
0.00	3.00	0.00	0.00	0.00
3.00	3.05	9.08	0.00	0.11
4.00	3.10	12.15	0.00	0.11
5.00	3.15	15.28	0.00	0.11
6.00	3.20	18.45	72.0	0.11
7.00	3.25	21.68	225.0	0.11

END FTABLE 34

FTABLE 35
 ROWS COLS *** REVISED 11/19/97 BASED ON HECRAS MODEL
 5 4

DEPTH	AREA	VOLUME	OUTFLOW	***
0.00	0.10	0.00	0.00	
1.00	1.10	0.60	38.00	
2.00	1.20	1.75	108.00	
3.00	1.30	3.00	194.00	
4.00	1.40	4.35	290.00	

END FTABLE 35

FTABLE 38
 ROWS COLS ***
 7 4

DEPTH	AREA	VOLUME	OUTFLOW	***
0.000	0.0000	0.0000	0.00	
1.000	0.4000	0.4000	2.00	
1.500	0.5000	1.0000	4.00	
2.000	0.9000	1.3000	11.00	
2.500	1.3000	1.6000	15.00	
3.000	1.6000	2.0000	18.00	
3.500	1.9000	2.5000	20.80	

END FTABLE 38

FTABLE 45
 ROWS COLS ***
 4 4

DEPTH	AREA	VOLUME	OUTFLOW	***
0.000	0.0010	0.0000	0.00	
0.000	0.0100	0.0100	10.00	
0.100	0.1000	0.1000	100.00	
1.000	1.0000	1.0000	1000.00	
10.000	10.0000	10.0000	10000.00	

END FTABLE 45

FTABLE 645
 ROWS COLS ***
 4 4

DEPTH	AREA	VOLUME	OUTFLOW	***
0.000	0.0010	0.0000	0.00	
0.000	0.0100	0.0100	10.00	
0.100	0.1000	0.1000	100.00	
1.000	1.0000	1.0000	1000.00	
10.000	10.0000	10.0000	10000.00	

END FTABLE645

FTABLE 50
 ROWS COLS ***
 10 4

DEPTH	AREA	VOLUME	OUTFLOW	***
0.00	1.00	0.00	0.00	
0.50	1.10	0.53	5.00	
1.00	1.20	1.10	15.00	
1.50	1.30	1.73	25.00	
2.00	1.40	2.40	35.00	
2.50	1.50	3.13	52.00	
3.00	1.60	3.90	70.00	
3.50	1.70	4.73	87.00	
4.00	1.80	5.60	105.00	
6.00	1.90	9.30	165.00	

END FTABLE 50

FTABLE 52
 ROWS COLS ***
 6 4

DEPTH	AREA	VOLUME	OUTFLOW	***
0.000	0.0000	0.0000	0.00	
0.100	0.3680	0.0184	0.25	
0.500	0.3717	0.1664	9.39	
1.000	0.3763	0.3534	31.06	
2.000	0.3819	0.7325	94.37	
3.000	0.3874	1.1171	174.33	

END FTABLE 52

FTABLE 552
 ROWS COLS *** SDN1 VAULT EFFECTIVE DEPTH=12 FT RISER=24 INCHES
 15 4

DEPTH	AREA	VOLUME	OUTFLOW	***
0.000	0.4308	0.0000	0.00	
1.290	0.4308	0.6520	0.111	
2.130	0.4308	1.0760	0.143	
3.530	0.4308	1.7830	0.184	
4.640	0.4308	2.3430	0.211	
5.200	0.4308	2.6260	0.223	
6.320	0.4308	3.1920	0.246	
7.430	0.4308	3.7530	0.267	
8.200	0.4308	4.1410	0.280	
9.220	0.4308	4.6570	0.407	
10.190	0.4308	5.1460	0.567	
11.250	0.4308	5.6820	0.954	
12.100	0.4308	6.1110	2.130	
12.300	0.4308	6.2120	4.730	
13.700	0.4308	6.9190	21.360	

END FTABLE552

FTABLE 53
 OLD LAKE REBA
 MAX DEPTH = 4.9 FEET
 30" CMP, 40 CFS DISCHARGE AT MAX DEPTH
 ROWS COLS ***
 7 4

DEPTH	AREA	VOLUME	OUTFLOW	***
0.000	2.4000	0.0000	0.00	
1.000	2.5800	2.5000	18.00	
2.000	2.9400	5.3000	26.00	
3.000	3.4100	8.4000	31.00	
4.000	3.8800	12.100	36.00	
4.900	4.3000	15.800	40.00	
6.000	4.3000	15.810	500.00	

END FTABLE 53

FTABLE 54
 EXISTING MILLER CREEK DETENTION FACILITY*** REVISED STORAGE/Q DATA
 GATE SETTING: 2.0 FEET*** BASED ON CALIBRATION FILE
 ROWS COLS ***
 12 4

DEPTH	AREA	VOLUME	OUTFLOW	***
0.000	0.00	0.00	0.00	
1.300	0.01	0.01	10.00	
2.000	0.01	0.02	20.00	
2.900	0.70	0.40	30.00	
4.000	1.50	1.50	40.00	
5.400	3.50	4.90	50.00	

7.000	8.60	13.30	60.00
8.800	15.60	34.80	70.00
10.000	19.90	57.30	76.00
10.500	21.50	68.00	92.00
11.000	23.10	78.80	179.00
11.500	24.70	88.60	303.00

END FTABLE 54

FTABLE 104

MILLER CREEK DETENTION FACILITY*** WITH ADD'L AREA 1+AREA 2 55.5 ACFT @ 10FT
GATE SETTING: 2.0 FEET*** EXISTING OUTLET NO LOW FLOW CONTROL

ROWS COLS ***

17 4

DEPTH	AREA	VOLUME	OUTFLOW	***
0.000	0.0000	0.0000	0.00	
0.500	0.0100	0.0100	2.50	
1.500	0.0300	0.2800	14.29	
2.500	1.1100	1.3900	24.88	
3.500	2.6100	4.0000	34.51	
4.500	4.6100	9.1400	43.20	
5.500	7.1200	19.600	50.98	
6.000	8.3600	21.180	54.53	
6.500	11.870	30.060	57.87	
7.000	15.370	38.930	61.00	
7.500	18.870	47.800	63.91	
8.000	21.860	59.160	66.62	
8.500	24.850	70.510	69.12	
9.000	27.340	84.160	71.42	
9.500	29.820	97.820	73.53	
10.000	32.050	112.83	75.44	
10.500	34.275	127.84	90.74	
11.500	38.220	161.54	320.00	

END FTABLE104

FTABLE 69

PRE-MILLER CREEK DETENTION FACILITY***

ROWS COLS ***

12 4

DEPTH	AREA	VOLUME	OUTFLOW	***
0.000	0.0000	0.0000	0.00	
0.100	0.1860	0.0093	0.12	
0.500	0.2552	0.0975	4.84	
1.000	0.3417	0.2467	18.49	
1.500	0.4282	0.4392	41.30	
2.000	0.5148	0.6750	74.40	
2.500	0.6013	0.9540	119.01	
3.000	0.6878	1.2763	176.30	
3.500	0.7744	1.6418	247.41	
4.000	0.8609	2.0506	333.43	
4.500	0.9470	2.4992	434.59	
5.000	1.0331	2.9905	552.33	

END FTABLE 69

*** PROJECT CONDITION PONDS/VAULTS

FTABLE 452

ROWS COLS ***

*** NEW NORTH EMPLOYEE PARKING LOT VAULT (NEPL)

*** PARALLEL VAULT BASED ON KCRTS EFFECTIVE DEPTH=20 FT

20 4

DEPTH	AREA	VOLUME	OUTFLOW	***
0.00	3.214	0.000	0.000	
1.11	3.214	0.826	0.129	

Page 24

1.57	3.214	1.168	0.154
3.43	3.214	2.551	0.227
4.83	3.214	3.593	0.269
8.08	3.214	6.010	0.348
10.41	3.214	7.743	0.395
12.74	3.214	9.476	0.437
14.00	3.214	10.413	0.458
14.65	3.214	10.897	0.557
16.09	3.214	11.968	0.665
16.23	3.214	12.072	0.754
17.92	3.214	13.329	1.140
18.22	3.214	13.552	1.310
18.81	3.214	13.991	1.860
19.11	3.214	14.214	2.190
20.00	3.214	14.876	3.350
20.20	3.214	15.025	5.110
20.70	32.14	15.397	14.820
21.00	32.14	15.620	18.560

END FTABLE452

FTABLE 451

ROWS COLS ***

*** NORTH EMPLOYEE PARKING LOT VAULT (NEPL)

*** EXISTING VAULT W/MODIFIED OUTLET EFFECTIVE DEPTH= 18.0 FT

14	4			
DEPTH	AREA	VOLUME	OUTFLOW	***
0.000	0.2240	0.0000	0.00	
2.170	0.2240	0.4860	0.031	
4.260	0.2240	0.9550	0.043	
5.930	0.2240	1.3290	0.051	
8.030	0.2240	1.8000	0.059	
10.120	0.2240	2.2680	0.066	
12.210	0.2240	2.7360	0.073	
14.040	0.2240	3.1460	0.109	
15.510	0.2240	3.4760	0.166	
16.220	0.2240	3.6350	0.295	
18.000	0.2240	4.0340	1.080	
18.400	0.2240	4.1240	5.400	
19.000	0.2240	4.2580	12.680	
19.900	0.2240	4.4600	17.080	

END FTABLE451

FTABLE 46

ROWS COLS ***

SDN-6: 24TH STREET CARGO VAULT *** EFFECTIVE DEPTH=14 FT RISER DIA=12 IN

20	4			
DEPTH	AREA	VOLUME	OUTFLOW	***
0.00	0.35	0.000	0.000	
0.37	0.35	0.131	0.021	
1.19	0.35	0.421	0.037	
3.39	0.35	1.198	0.063	
5.03	0.35	1.778	0.077	
7.23	0.35	2.556	0.092	
9.15	0.35	3.235	0.104	
10.25	0.35	3.624	0.110	
10.53	0.35	3.723	0.111	
10.92	0.35	3.861	0.128	
12.00	0.35	4.242	0.165	
12.13	0.35	4.288	0.190	
12.95	0.35	4.578	0.245	
13.77	0.35	4.868	0.282	

Page 25

14.00	0.35	4.949	0.291
14.10	0.35	4.985	0.910
14.20	0.35	5.020	2.040
14.30	0.35	5.056	3.500
14.50	0.35	5.126	7.200
14.70	0.35	5.197	11.720

END FTABLE 46

*** SDW-1A: 3RD RUNWAY POND G TO MILLER CREEK (LEVEL 2): ***

FTABLE 47
 *** PROJECT SDW1A EFFECTIVE DIAMETER=3.0 FT
 ROWS COLS *** INFILTRATION TANK TO OBTAIN 0.3 CFS

14	5				
DEPTH	AREA	VOLUME	STORMQ	INFILTRQ	***
0.000	0.000	0.000	0.000	0.000	
0.250	0.002	0.002	0.000	0.027	
0.500	0.004	0.004	0.000	0.054	
1.000	0.012	0.012	0.000	0.109	
1.500	0.020	0.020	0.000	0.164	
2.000	0.029	0.029	0.000	0.218	
2.500	0.036	0.036	0.000	0.272	
3.000	0.041	0.0406	0.000	0.327	
3.100	0.041	0.0419	0.596	0.338	
3.200	0.041	0.0420	1.685	0.349	
3.300	0.041	0.0421	3.096	0.360	
3.400	0.041	0.0422	4.766	0.371	
3.500	0.041	0.0423	6.661	0.382	
3.750	0.041	0.0424	12.237	0.409	

END FTABLE 47

*** SDW-1A: 3RD RUNWAY NORTH POND G TO MILLER CREEK (LEVEL 2): ***

FTABLE 147
 *** PROJECT SDW1A EFFECTIVE DEPTH=14.0 FT RISER DIA 24 INCHES
 ROWS COLS *** VAULT BASED ON INFILTRATION=0.15CFS

17	5				
DEPTH	AREA	VOLUME	INFILTRQ	BYPASS Q	***
0.000	0.689	0.000	0.0000	0.0000	
0.010	0.689	0.007	0.1400	0.0000	
1.000	0.689	0.689	0.1408	0.0000	
2.000	0.689	1.377	0.1417	0.0000	
4.000	0.689	2.755	0.1432	0.0000	
6.000	0.689	4.132	0.1446	0.0000	
8.000	0.689	5.510	0.1461	0.0000	
10.000	0.689	6.887	0.1475	0.0000	
12.000	0.689	8.264	0.1489	0.0000	
14.000	0.689	9.642	0.1503	0.0000	
16.000	0.689	11.019	0.1517	0.0000	
16.750	0.689	11.536	0.1517	10.7600	
16.900	0.689	11.639	0.1517	13.9600	
17.000	0.689	11.708	0.1517	16.1000	
17.100	0.689	11.777	0.1517	18.5700	
17.300	0.689	11.915	0.1517	23.8600	
18.000	0.689	12.397	0.1517	45.5400	

END FTABLE147

*** SDW-1A: 3RD RUNWAY NORTH POND G TO MILLER CREEK (LEVEL 2): ***

FTABLE 247
 *** PROJECT SDW1A EFFECTIVE DEPTH=12.0 FT RISER DIA 12 INCHES
 ROWS COLS *** POND BASED ON INFILTRATION=0.15CFS

17	5				
DEPTH	AREA	VOLUME	STORMQ	INFILTRQ	***
0.000	1.300	0.000	0.00	0.00	

0.010	1.310	0.010	0.001	0.15
1.000	1.320	1.320	0.007	0.15
2.000	1.342	2.650	0.010	0.15
3.000	1.363	4.000	0.012	0.15
4.000	1.385	5.370	0.013	0.15
5.000	2.672	8.000	0.015	0.15
6.000	2.739	10.700	0.017	0.15
7.000	2.807	13.470	0.018	0.15
8.000	2.876	16.300	0.019	0.15
8.300	2.896	17.176	0.031	0.15
9.000	2.945	19.210	0.041	0.15
10.000	3.014	22.180	0.051	0.15
11.000	3.084	25.228	0.058	0.15
11.100	3.092	25.540	0.675	0.15
11.300	3.106	26.162	3.260	0.15
12.000	3.155	28.340	15.190	0.15

END FTABLE247

*** SDN3A: 3RD RUNWAY VAULT TO MILLER CREEK (LEVEL 2): ***

FTABLE 37
 *** PROJECT C SDN3A EFFECTIVE DEPTH=11.0FT RISER DIA=24 INCHES
 VAULT BASED ON IMPERVIOUS TOP SURO

ROWS	COLS	DEPTH	AREA	VOLUME	OUTFLOW	***
14	4	0.000	0.644	0.000	0.000	
		0.010	0.644	0.006	0.001	
		1.000	0.644	0.643	0.016	
		3.980	0.644	2.558	0.033	
		6.030	0.644	3.876	0.041	
		9.010	0.644	5.792	0.050	
		10.00	0.644	6.428	0.052	
		10.46	0.644	6.724	0.072	
		11.00	0.644	7.071	0.082	
		11.10	0.644	7.135	0.699	
		11.20	0.644	7.199	1.830	
		11.30	0.644	7.264	3.290	
		11.40	0.644	7.328	5.020	
		11.60	0.644	7.456	9.140	

END FTABLE 37

*** SDN3A: 3RD RUNWAY POND C TO MILLER CREEK (LEVEL 2): ***

FTABLE 237
 *** PROJECT C SDN3A EFFECTIVE DEPTH= 9.0FT RISER DIA=24 INCHES
 POND BASED ON INTERFLOW AND PERVIOUS TOP SURO

ROWS	COLS	DEPTH	AREA	VOLUME	OUTFLOW	***
19	4	0.000	1.3090	0.000	0.00	
		0.020	1.3120	0.026	0.009	
		1.020	1.3550	1.358	0.070	
		2.070	1.4030	2.806	0.100	
		3.130	1.4530	4.320	0.123	
		4.020	1.4980	5.632	0.139	
		5.070	1.5460	7.229	0.156	
		7.750	1.6720	11.549	0.193	
		7.800	1.6800	11.633	0.199	
		7.850	1.6840	11.718	0.213	
		8.250	1.7050	12.395	0.249	
		8.340	1.7090	12.549	0.270	
		8.570	1.7210	12.944	0.313	
		8.950	1.7410	13.601	0.354	
		9.500	1.7690	14.567	0.399	
		9.600	1.7740	14.744	0.714	
		9.800	1.7850	15.100	2.020	

10.300 1.8110 15.999 3.840
 10.900 1.8430 17.095 4.960
 END FTABLE237

*** SDN-3X: 3RD RUNWAY NORTH VAULT (LEVEL 2): ***

FTABLE 43
 ROWS COLS *** EFFECTIVE DEPTH=20 FT RISER DIA=24 INCHES
 21 4

DEPTH (FT)	AREA (ACRES)	VOLUME (ACRE-FT)	FLOW (FT3/S)
0.00	1.288	0.00	0.00
0.14	1.288	0.180	0.067
1.39	1.288	1.790	0.216
3.35	1.288	4.314	0.336
5.31	1.288	6.839	0.423
8.06	1.288	10.380	0.521
8.84	1.288	11.385	0.545
10.02	1.288	12.905	0.580
11.98	1.288	15.429	0.635
12.37	1.288	15.931	0.645
14.00	1.288	18.030	0.686
14.10	1.288	18.159	0.705
14.91	1.288	19.202	0.757
16.09	1.288	20.722	0.810
18.00	1.288	23.182	0.881
18.32	1.288	23.594	1.150
18.76	1.288	24.161	1.360
20.00	1.288	25.758	1.680
20.10	1.288	25.886	2.320
20.50	1.288	26.402	8.620
20.80	1.288	26.788	15.370

END FTABLE 43

*** SDN-4X/2X: 3RD RUNWAY NORTH VAULT (COMBINED FACILITY)

FTABLE 51
 ROWS COLS *** EFFECTIVE DEPTH=19FT RISER DIA=24 INCHES
 20 4

DEPTH (FT)	AREA (ACRES)	VOLUME (ACRE-FT)	OUTFLOW (FT3/S)
0.00	0.789	0.000	0.000
0.16	0.789	0.126	0.056
1.51	0.789	1.192	0.169
3.28	0.789	2.588	0.249
5.49	0.789	4.332	0.322
7.26	0.789	5.729	0.370
10.35	0.789	8.168	0.442
12.12	0.789	9.564	0.478
13.44	0.789	10.606	0.503
14.33	0.789	11.308	0.520
15.57	0.789	12.287	0.654
16.72	0.789	13.194	0.828
17.19	0.789	13.565	0.950
17.63	0.789	13.913	1.030
18.00	0.789	14.205	1.080
19.00	0.789	14.994	1.960
19.10	0.789	15.073	2.580
19.40	0.789	15.309	6.930
19.60	0.789	15.467	11.080
20.00	0.789	15.783	17.190

END FTABLE 51

*** SDW-1B: 3RD RUNWAY CENTRAL SOUTH POND D TO MILLER CREEK (LEVEL 2): ***

FTABLE 57

*** EFFECTIVE DEPTH = 14.0 FT

ROWS	COLS	DEPTH (FT)	AREA (ACRES)	VOLUME (ACRE-FT)	STORMQ (FT3/S)	***
17	4	0.00	2.430	0.000	0.000	***
		0.01	2.430	0.041	0.010	***
		1.00	2.680	2.411	0.183	
		2.00	2.760	4.860	0.257	
		3.00	2.818	7.370	0.319	
		4.00	3.079	9.945	0.366	
		5.00	5.832	15.320	0.411	
		6.00	5.927	20.742	0.450	
		7.00	6.022	26.264	0.481	
		8.00	6.118	31.888	0.518	
		9.00	6.210	37.613	0.550	
		10.00	6.311	43.441	0.583	
		11.00	6.408	49.372	0.609	
		12.00	6.607	55.406	0.634	
		13.00	6.405	61.543	0.764	
		14.00	6.504	67.786	1.320	
		15.00	7.000	70.000	16.600	

END FTABLE 57

*** SDW-1B:3RD RUNWAY CENTRAL SOUTH POND D TO MILLER CREEK (LEVEL 2): ***

FTABLE 257

*** PROJECT SDW1B EFFECTIVE DIAMETER=3.0 FT
INFILTRATION TANK TO OBTAIN 0.2 CFS

ROWS	COLS	DEPTH	AREA	VOLUME	STORMQ	INFILTRQ	***
15	5	0.000	0.001	0.000	0.000	0.000	***
		0.010	0.001	0.001	0.000	0.002	
		0.250	0.002	0.002	0.000	0.017	
		0.500	0.004	0.004	0.000	0.035	
		1.000	0.012	0.012	0.000	0.071	
		1.500	0.020	0.020	0.000	0.106	
		2.000	0.029	0.029	0.000	0.142	
		2.500	0.036	0.036	0.000	0.178	
		3.000	0.041	0.0406	0.000	0.213	
		3.100	0.041	0.0420	0.596	0.220	
		3.200	0.041	0.0421	1.685	0.227	
		3.300	0.041	0.0422	3.096	0.233	
		3.400	0.041	0.0423	4.766	0.241	
		3.500	0.041	0.0424	6.661	0.248	
		3.750	0.041	0.0425	12.237	0.266	

END FTABLE257

FTABLE 570

*** PROJECT SDW1B FLOW SPLITTER (to 257 and 57)

ROWS	COLS	DEPTH	AREA	VOLUME	STORMQ	INFILTRQ	***
15	5	0.000	0.00	0.000	0.000	0.000	***
		0.100	0.01	0.0002	0.000	0.050	
		0.400	0.01	0.0009	0.000	0.110	
		0.600	0.01	0.0014	0.000	0.130	
		0.750	0.01	0.0017	0.000	0.150	
		0.800	0.01	0.0018	0.720	0.150	
		1.000	0.01	0.0023	8.050	0.170	
		1.100	0.01	0.0025	13.330	0.180	
		1.200	0.01	0.0027	19.440	0.190	
		1.300	0.01	0.0030	26.270	0.190	
		1.400	0.01	0.0032	33.750	0.200	
		1.420	0.01	0.0033	35.320	0.200	

1.440	0.01	0.0033	36.910	0.200
1.450	0.01	0.0034	37.920	0.200
1.460	0.01	0.0035	38.530	0.200

END FTABLE570

FTABLE 61
 ROWS COLS ***
 *** SDN-2X: DETAIN OVERFLOW FROM NCPS AND NSMPS-

DEPTH	AREA	VOLUME	OUTFLOW	***
17	4			
0.000	0.5740	0.0000	0.00	
1.200	0.5740	0.7710	0.151	
2.220	0.5740	1.4270	0.205	
3.240	0.5740	2.0830	0.247	
3.650	0.5740	2.3460	0.262	
4.260	0.5740	2.7380	0.283	
4.660	0.5740	2.9950	0.296	
5.680	0.5740	3.6510	0.327	
6.640	0.5740	4.2680	0.517	
7.650	0.5740	4.9170	0.644	
8.670	0.5740	5.9710	0.739	
9.810	0.5740	6.3570	0.836	
10.700	0.5740	6.8780	0.894	
12.000	0.5740	7.7130	0.978	
12.100	0.5740	7.7780	1.600	
12.300	0.5740	7.9060	4.200	
12.800	0.5740	8.2280	14.560	

END FTABLE 61

PRE AMBAUM DETENTION ***
 FTABLE 111

DEPTH	AREA	VOLUME	OUTFLOW	***
15	4			
0.000	0.0000	0.0000	0.00	
0.500	0.2160	0.0750	5.30	
1.000	0.2730	0.1990	21.10	
1.500	0.2890	0.3410	43.90	
2.000	0.2900	0.4830	68.80	
2.500	0.2910	0.6070	89.10	
3.000	0.2950	0.6820	90.00	
3.500	0.3000	2.1000	100.00	
4.000	0.3050	2.5000	105.00	
4.500	0.3100	3.0000	110.00	
5.000	0.3200	3.5000	120.00	
5.500	0.3300	4.0000	130.00	
6.000	0.3800	5.0530	166.48	
6.500	0.3980	5.9430	225.31	
7.000	0.4150	6.9040	320.10	

END FTABLE111

FTABLE 135
 ROWS COLS *** VACA FARM

DEPTH	AREA	VOLUME	OUTFLOW	***
6	4			
0.00	0.10	0.00	0.00	
1.00	0.10	0.10	4.00	
2.00	0.11	0.21	8.00	
2.50	1.00	0.48	13.00	
3.50	6.50	4.23	86.00	
4.50	13.00	13.98	235.00	

END FTABLE135

```

FTABLE 240
*** NORTH SNOWMELT PUMP STATION (SDN-2) (INSTALLED IN LATE 1997/1998) ***
ROWS COLS
14 5
DEPTH AREA VOLUME (IWS) (SDS)
(FT) (ACRES) (ACRE-FT) (CFS) (CFS)
0.0 0.002 0.00 0.00 0.00
1.00 0.002 0.0023 0.00 0.00
2.00 0.002 0.0046 1.67 0.00
3.00 0.002 0.0069 1.67 0.00
4.00 0.002 0.0092 1.67 0.00
5.00 0.002 0.0115 1.67 0.00
5.25 0.002 0.0121 1.67 1.53
5.50 0.002 0.0126 1.67 6.06
5.75 0.002 0.0132 1.67 12.65
6.00 0.002 0.0138 1.67 19.83
6.25 0.002 0.0144 1.67 25.66
6.50 0.002 0.0149 1.67 25.70
6.75 0.002 0.0155 1.67 26.70
7.00 0.002 0.0161 1.67 50.00
END FTABLE240
    
```

```

FTABLE 242
*** NORTH CARGO PUMP STATION (SDN-2) (INSTALLED IN OCTOBER 1997) ***
ROWS COLS
14 5
DEPTH AREA VOLUME (IWS) (SDS)
(FT) (ACRES) (ACRE-FT) (CFS) (CFS)
0.0 0.002 0.00 0.00 0.00
1.00 0.002 0.0023 0.00 0.00
2.00 0.002 0.0046 6.13 0.00
3.00 0.002 0.0069 6.13 0.00
4.00 0.002 0.0092 6.13 0.00
5.00 0.002 0.0115 6.13 0.00
5.25 0.002 0.0121 6.13 0.28
5.50 0.002 0.0126 6.13 1.16
5.75 0.002 0.0132 6.13 2.53
6.00 0.002 0.0138 6.13 4.23
6.25 0.002 0.0144 6.13 6.05
6.50 0.002 0.0149 6.13 7.72
6.75 0.002 0.0155 6.13 8.50
7.00 0.002 0.0161 6.13 20.0
END FTABLE242
    
```

END FTABLES

```

MASS-LINK
<Volume> <-Grp> <-Member-><--Mult--> <Target> <-Grp> <-Member->***
<Name> <Name> # <-factor-> <Name> <Name> # #***
MASS-LINK 1
conversion from acre-inches to acre-ft (1/12) ***
PERLND PWATER PERO 0.0833333 RCHRES INFLOW IVOL
END MASS-LINK 1

MASS-LINK 2
IMPLND IWATER SURO 0.0833333 RCHRES INFLOW IVOL
END MASS-LINK 2

MASS-LINK 3
RCHRES ROFLOW RCHRES INFLOW
END MASS-LINK 3

MASS-LINK 4
    
```

```

RCHRES      OFLOW  OVOL  1      RCHRES      INFLOW  IVOL
END MASS-LINK      4

      MASS-LINK      5
RCHRES      OFLOW  OVOL  2      RCHRES      INFLOW  IVOL
END MASS-LINK      5

      MASS-LINK      6
PERLND      PWATER  SURO  0.0833333  RCHRES      INFLOW  IVOL
PERLND      PWATER  IFWO  0.0833333  RCHRES      INFLOW  IVOL
END MASS-LINK      6

      MASS-LINK      7
PERLND      PWATER  AGWO  0.0833333  RCHRES      INFLOW  IVOL
END MASS-LINK      7

      MASS-LINK      10
COPY        OUTPUT  MEAN
END MASS-LINK      10

      MASS-LINK      11
RCHRES      ROFLOW
END MASS-LINK      11

      MASS-LINK      12
COPY        OUTPUT  MEAN
END MASS-LINK      12

      MASS-LINK      14
RCHRES      OFLOW  OVOL  1      COPY        INPUT  MEAN
END MASS-LINK      14

      MASS-LINK      15
RCHRES      OFLOW  OVOL  2      COPY        INPUT  MEAN
END MASS-LINK      15

      MASS-LINK      21
PERLND      PWATER  PERO  0.0833333  COPY        INPUT  MEAN
END MASS-LINK      21

      MASS-LINK      22
IMPLND      IWATER  SURO  0.0833333  COPY        INPUT  MEAN
END MASS-LINK      22

      MASS-LINK      26
PERLND      PWATER  SURO  0.0833333  COPY        INPUT  MEAN
PERLND      PWATER  IFWO  0.0833333  COPY        INPUT  MEAN
END MASS-LINK      26

      MASS-LINK      27
PERLND      PWATER  AGWO  0.0833333  COPY        INPUT  MEAN
END MASS-LINK      27

      MASS-LINK      28
RCHRES      OFLOW  OVOL  2      12      PERLND      EXTNL  AGWLI
END MASS-LINK      28

```

END MASS-LINK

COPY
TIMESERIES
Copy-opn

#	-	#	NPT	NMN
37	-	71		1
240	-	242		1
357	-	357		1
645	-	645		1

END TIMESERIES
END COPY
END RUN

**WALKER CREEK WATERSHED
HSPF INPUT FILES**

- 1994 CONDITIONS
- 2006 CONDITIONS

1994 CONDITIONS

AR 020334

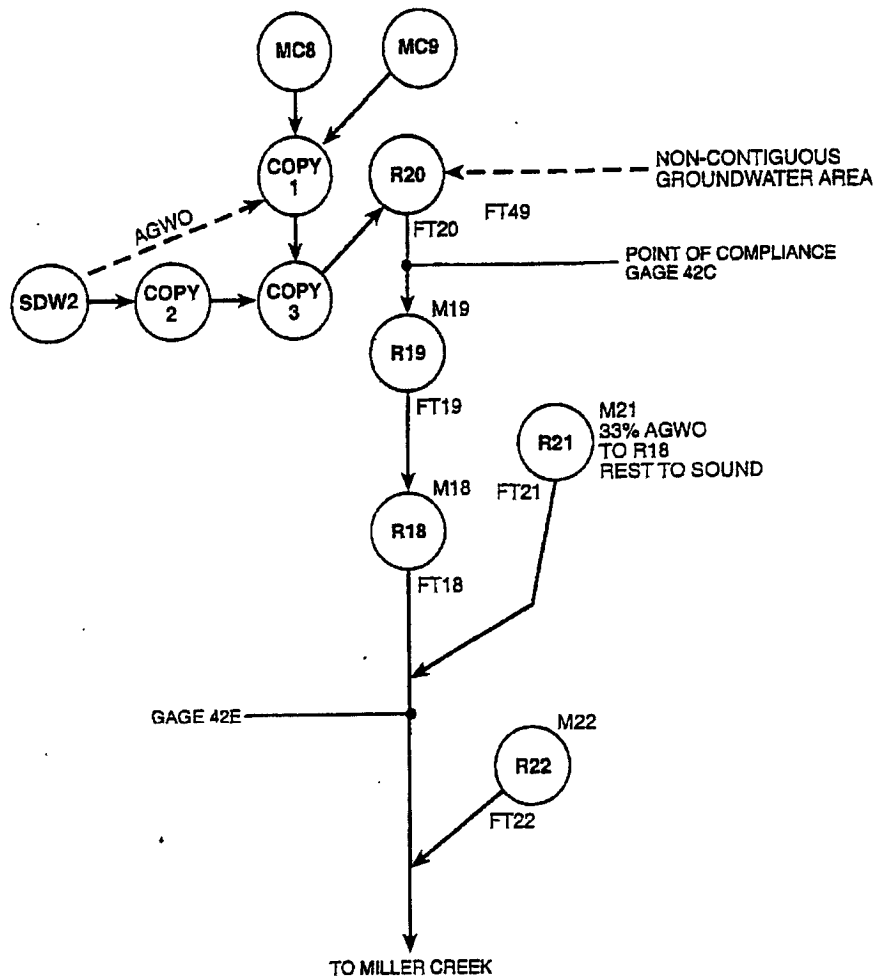

Parametrix, Inc. Part of Seattle/556-2912-001/01 (28B) 12/01 (K)

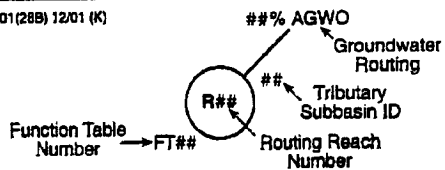

**HSPF Model Schematic
Walker Creek
Low Flow Analysis
1994 Conditions**

```

RUN
GLOBAL
*** COPY COMMAND ADDED
*** FILE: WCPREDT.inp REVISED OCTOBER 2000
*** SEATAC AIRPORT HSPF BASIN MODEL OF WALKER CREEK
*** CALIBRATION FILE USING FULL LENGTH RUN 1990 DATA FOR INTITIAL CONDITIONS
WALKER CREEK BASIN HSPF MODEL
START      1990 10 1 0 0 END      1994 9 30 24 0
RUN INTERP OUTPUT LEVEL 3
RESUME     0 RUN      1
END GLOBAL
    
```

```

FILES
<type> <fun>***<-----fname----->
MESSU    24 D:\PARA\SEATAC\MILLER\LOWFLOW\wpredt.MES
WDM      25 D:\PARA\SEATAC\MILLER\LOWFLOW\m\lowflow.WDM
         61 D:\PARA\SEATAC\MILLER\LOWFLOW\WPER.L61
         62 D:\PARA\SEATAC\MILLER\LOWFLOW\WRCH.L62
END FILES
    
```

```

OPN SEQUENCE
INGRP                                INDELT 01:00
  PERLND      14
  PERLND      16
  PERLND      18
  PERLND      24
  PERLND      26
  PERLND      28
  PERLND      34
  PERLND      44
  PERLND      45
  PERLND      54
  PERLND      64
  PERLND      65
  IMPLND      14
  COPY         2
  COPY         1
  COPY         3
  RCHRES      20
  RCHRES      19
  RCHRES      18
END INGRP
END OPN SEQUENCE
    
```

```

COPY
TIMESERIES
Copy-opn
# - # NPT NMN
1 5 1
END TIMESERIES
END COPY
    
```

```

PERLND
GEN-INFO
<PLS >
# - #
Name NBLKS User t-series Eng] Metr
in out
14 TFF- TILL FOR FLT 1 1 1 1 61 0
16 TFM- TILL FOR MOD 1 1 1 1 61 0
18 TFS- TILL FOR STP 1 1 1 1 61 0
24 TGF- TILL GR FLT 1 1 1 1 61 0
26 TGM- TILL GR MOD 1 1 1 1 61 0
28 TGS- TILL GR STP 1 1 1 1 61 0
Page 1
    
```

```

34 OF - OUTWASH FOR 1 1 1 1 61 0
44 OG - OUTWASH GR 1 1 1 1 61 0
***PERLND FOR NEW AIRPORT FILL; NONE IN CALIBRATION
45 AIRPORT FILL 1 1 1 1 61 0
54 SA - WETLANDS 1 1 1 1 61 0
64 TGM DES MOINES 1 1 1 1 61 0
65 OG DES MOINES 1 1 1 1 61 0
    
```

END GEN-INFO

ACTIVITY

```

<PLS > ***** Active Sections *****
# - # ATMP SNOW PWAT SED PST PWG PQAL MSTL PEST NITR PHOS TRAC ***
14 200 0 0 1 0 0 0 0 0 0 0 0 0
    
```

END ACTIVITY

PRINT-INFO

```

<PLS > ***** Print-flags ***** PIVL PYR
# - # ATMP SNOW PWAT SED PST PWG PQAL MSTL PEST NITR PHOS TRAC *****
14 200 0 0 5 0 0 0 0 0 0 0 0 0 1 9
    
```

END PRINT-INFO

PWAT-PARM1

```

<PLS > ***** Flags *****
# - # CSNO RTOP UZFG VCS VUZ VNN VIFW VIRG VLE ***
14 0 0 0 0 0 0 0 0 0
16 0 0 0 0 0 0 0 0 0
18 0 0 0 0 0 0 0 0 0
24 0 0 0 0 0 0 0 0 0
26 0 0 0 0 0 0 0 0 0
28 0 0 0 0 0 0 0 0 0
34 0 0 0 0 0 0 0 0 0
44 0 0 0 0 0 0 0 0 0
45 0 0 0 0 0 0 0 0 0
54 0 0 0 0 0 0 0 0 0
64 0 0 0 0 0 0 0 0 0
    
```

END PWAT-PARM1

PWAT-PARM2

```

<PLS > ***
# - # ***FOREST LZSN INFILT LSUR SLSUR KVARV AGWRC
14 4.5000 0.0800 400.00 0.0500 0.5000 0.9960
16 4.5000 0.0800 400.00 0.1000 0.5000 0.9960
18 4.5000 0.0800 200.00 0.2000 0.5000 0.9960
24 4.5000 0.0300 400.00 0.0500 0.5000 0.9960
26 4.5000 0.0300 400.00 0.1000 0.5000 0.9960
28 4.5000 0.0300 200.00 0.2000 0.5000 0.9960
34 5.0000 2.0000 400.00 0.0500 0.3000 0.9960
44 5.0000 0.8000 400.00 0.0500 0.3000 0.9960
45 7.5000 0.0200 300.00 0.0700 0.0000 0.9960
54 4.0000 2.0000 100.00 0.0010 0.5000 0.9960
64 4.5000 0.1200 400.00 0.1000 0.5000 0.9990
65 5.0000 0.8000 400.00 0.0500 0.5000 0.9960
    
```

END PWAT-PARM2

PWAT-PARM3

```

<PLS > ***
# - #*** PETMAX PETMIN INFEXP INFILD DEEPFR BASETP AGWETP
14 2.0000 2.0000 2.0000 0.00 0.00 0.0
16 2.0000 2.0000 2.0000 0.00 0.00 0.0
18 2.0000 2.0000 2.0000 0.00 0.00 0.0
24 2.0000 2.0000 2.0000 0.00 0.00 0.0
26 2.0000 2.0000 2.0000 0.00 0.00 0.0
28 2.0000 2.0000 2.0000 0.00 0.00 0.0
34 2.0000 2.0000 2.0000 0.00 0.00 0.0
44 2.0000 2.0000 2.0000 0.00 0.00 0.0
45 2.0000 2.0000 2.0000 0.00 0.00 0.0
54 10.0000 2.0000 2.0000 0.00 0.00 0.7
64 2.0000 2.0000 2.0000 0.00 0.00 0.0
    
```

END PWAT-PARM3

PWAT-PARM4

<PLS >

#	#	CEPSC	UZSN	NSUR	INTFW	IRC	LZETP***
14		0.2000	1.0000	0.3500	2.000	0.1500	0.7000
16		0.2000	0.5000	0.3500	2.000	0.1500	0.7000
18		0.2000	0.3000	0.3500	2.000	0.1500	0.7000
24		0.1000	0.5000	0.2500	2.000	0.1500	0.2500
26		0.1000	0.2500	0.2500	2.000	0.1500	0.2500
28		0.1000	0.1500	0.2500	2.000	0.1500	0.2500
34		0.2000	0.5000	0.3500	0.000	0.5000	0.7000
44		0.1000	0.5000	0.2500	0.000	0.5000	0.2500
45		0.1000	0.2800	0.2500	6.000	0.1500	0.6000
54		0.1000	3.0000	0.5000	1.000	0.7000	0.8000
64		0.1000	0.2500	0.2500	3.000	0.5000	0.2500
65		0.1000	0.5000	0.2500	0.000	0.5000	0.2500

END PWAT-PARM4

PWAT-STATE1

<PLS > PWATER state variables***

#	#***	CEPS	SURS	UZS	IFWS	LZS	AGWS	GWVS
14		0.000	0.	0.0200	0.00	0.020	3.50	0.045
16		0.000	0.	0.0010	0.00	0.020	3.51	0.047
18		0.000	0.	0.0000	0.00	0.020	3.49	0.047
26		0.000	0.	0.0000	0.00	1.758	2.90	0.043
28		0.000	0.	0.0000	0.00	1.598	2.81	0.041
34		0.000	0.	0.0000	0.00	1.516	2.74	0.039
44		0.000	0.	0.0000	0.00	2.756	6.25	0.134
45		0.000	0.	0.0000	0.00	0.373	3.01	0.000
54		0.000	0.	0.3650	0.00	0.561	0.00	0.000
64		0.000	0.	0.0000	0.00	1.978	22.28	0.000
65		0.000	0.	0.0000	0.00	0.000	20.00	0.000
80		0.000	0.	0.0000	0.00	1.758	2.90	0.043

END PWAT-STATE1

END PERLND

IMPLND

GEN-INFO

<ILS >

-

Name	Unit-systems	Printer	User	t-series	Engl	Metr
14 IMPERVIOUS	1 1 1	60 0				

END GEN-INFO

ACTIVITY

<ILS > ***** Active Sections *****

- # ATMP SNOW IWAT SLD IWG IQAL ***

14 0 0 1 0 0 0

END ACTIVITY

PRINT-INFO

<ILS > ***** Print-flags ***** PIVL PYR

- # ATMP SNOW IWAT SLD IWG IQAL *****

14 0 0 6 0 0 0 1 9

END PRINT-INFO

IWAT-PARM1

<ILS >

-

Flags	CSNO	RTOP	VRS	VNN	RTLI
14	0	0	0	0	0

END IWAT-PARM1

IWAT-PARM2

<ILS >

-

LSUR	SLSUR	NSUR	RETSC
14	100.00	0.0100	0.1000

END IWAT-PARM2

IWAT-PARM3

<ILS >

```

# - # PETMAX PETMIN ***
14
END IWAT-PARM3
IWAT-STATE1 ***
<ILS > IWATER state variables ***
# - # RETS SURS ***
14 1.0000E-3 1.0000E-3
END IWAT-STATE1
END IMPLND ***

```

EXT SOURCES

*** NOTE: The only RCHRES that precip and PET are applied to are lakes. ***

```

<-Volume-> <Member> SsysSgap<--Mult-->Tran <-Target vols> <-Grp> <-Member-> ***
<Name> # <Name> # tem strg<-factor-->strg <Name> # # <Name> # # ***
*** PRECIP/EVAP TO PERVIOUS/IMPERV SURFACES
WDM 1002 PREC ENGLZERO 1.00 PERLND 14 200 EXTNL PREC
WDM 1002 PREC ENGLZERO 1.00 IMPLND 14 EXTNL PREC
WDM 1 EVAP ENGLZERO 0.8 PERLND 14 65 EXTNL PETINP
WDM 1 EVAP ENGLZERO 0.8 IMPLND 14 EXTNL PETINP
*** PRECIP/EVAP TO LAKES
WDM 1002 PREC ENGLZERO RCHRES 20 EXTNL PREC
WDM 1 EVAP ENGLZERO 0.8 RCHRES 20 EXTNL POTEV

```

END EXT SOURCES

EXT TARGETS

```

<-Volume-> <-Grp> <-Member-><--Mult-->Tran <-Volume-> <Member> Tsys Tgap Amd ***
<Name> # <Name> # <-factor-->strg <Name> # <Name> tem strg strg***
***WALKER NR MTH
RCHRES 18 HYDR RO *** WDM 96 FLOW ENGL REPL
*** MISC (20=WALKER WETLAND, 55=SR509, 56=1ST AVE)
RCHRES 20 HYDR RO WDM 8097 FLOW ENGL REPL
COPY *** 2 OUTPUT MEAN 1 1 12.1 WDM 89 FLOW ENGL REPL
END EXT TARGETS ***

```

SCHEMATIC

```

<-Source-> <--Area--> <-Target-> MBLK ***
<Name> # <-factor--> <Name> # Tbl# ***

```

***WALKER CREEK

```

*** SUB-CATCHMENT MC 8
PERLND 26 4.10 COPY 1 8
PERLND 44 18.57 COPY 1 8
PERLND 54 2.72 COPY 1 8
IMPLND 14 1.34 COPY 1 9
*** SUB-CATCHMENT SDW2 10-75-15 PREDEVELOPMENT W/1994 IMP
***PERLND 16 30.91 COPY 2 10
***PERLND 26 7.16 COPY 2 10
***PERLND 34 1.69 COPY 2 10
***PERLND 44 0.39 COPY 2 10
***PERLND 54 1.13 COPY 2 10
***PERLND 16 30.91 COPY 1 11
***PERLND 26 7.16 COPY 1 11
***PERLND 34 1.69 COPY 1 11
***PERLND 44 0.39 COPY 1 11
***PERLND 54 1.13 COPY 1 11
***IMPLND 14 3.31 COPY 2 9
*** SUB-CATCHMENT SDW2 10-75-15 PREDEVELOPMENT W/1994 IMP
***PERLND 26 4.37 COPY 2 10
***PERLND 34 16.47 COPY 2 10
***PERLND 44 4.39 COPY 2 10

```

***PERLND	54	1.05	COPY	2	10
***PERLND	16	16.38	COPY	1	11
***PERLND	26	4.37	COPY	1	11
***PERLND	34	16.47	COPY	1	11
***PERLND	44	4.39	COPY	1	11
***PERLND	54	1.05	COPY	1	11
***IMPLND	14	2.20	COPY	2	9
*** SUB-CATCHMENT SDW2 10-75-15 PREDEVELOPMENT W/1994 IMP					
PERLND	26	37.84	COPY	2	10
PERLND	44	2.32	COPY	2	10
PERLND	54	1.13	COPY	2	10
IMPLND	14	3.31	COPY	2	9
***add sdw2-b area from contig and non-contig					
***subtract from noncontig area just pervious					
***sdw2-a					
PERLND	26	10.64	COPY	2	11
PERLND	44	2.31	COPY	2	11
PERLND	54	0.68	COPY	2	11
IMPLND	14	1.14	COPY	2	9
***non-contig sdw2-b					
PERLND	26	13.74	COPY	2	11
PERLND	54	0.45	COPY	2	11
IMPLND	14	0.88	COPY	2	9
*** SUB-CATCHMENT MC 9					
PERLND	26	9.44	COPY	1	8
PERLND	44	0.74	COPY	1	8
PERLND	54	0.00	COPY	1	8
IMPLND	14	0.24	COPY	1	9
*** SUB-CATCHMENT 18					
PERLND	16	0.76	RCHRES	18	1
PERLND	26	16.08	RCHRES	18	1
PERLND	34	20.95	RCHRES	18	1
PERLND	44	49.22	RCHRES	18	1
IMPLND	14	3.30	RCHRES	18	2
*** SUB-CATCHMENT 19					
PERLND	16	12.72	RCHRES	19	1
PERLND	26	92.07	RCHRES	19	1
PERLND	34	8.39	RCHRES	19	1
PERLND	44	95.55	RCHRES	19	1
IMPLND	14	30.53	RCHRES	19	2
*** SUB-CATCHMENT 20					
PERLND	26	12.53	RCHRES	20	1
PERLND	44	53.43	RCHRES	20	1
PERLND	54	33.43	RCHRES	20	1
IMPLND	14	52.83	RCHRES	20	2
*** DOWN STREAM OF WALKER CREEK GAGE					
*** SUB-CATCHMENT 21 33% OF GW GOES TO GAGE REST GOES TO SOUND					
PERLND	16	2.54	RCHRES	18	7
PERLND	26	44.30	RCHRES	18	7
PERLND	34	2.03	RCHRES	18	7
PERLND	44	41.13	RCHRES	18	7
PERLND	16	2.54	RCHRES	21	6
PERLND	26	44.30	RCHRES	21	6
PERLND	34	2.03	RCHRES	21	6
PERLND	44	41.13	RCHRES	21	6
PERLND	16	5.07	RCHRES	21	1
PERLND	26	88.61	RCHRES	21	1
PERLND	34	4.06	RCHRES	21	1
PERLND	44	82.26	RCHRES	21	1
IMPLND	14	33.09	RCHRES	21	2
IMPLND	14	16.54	RCHRES	21	2

*** SUB-CATCHMENT 22
 PERLND 34
 PERLND 44
 PERLND 54
 IMPLND 14

4.30	RCHRES	22	1
19.49	RCHRES	22	1
3.21	RCHRES	22	1
3.95	RCHRES	22	2

***sds7a - contig

0.22	RCHRES	20	1
0.08	RCHRES	20	2

***sds7b - non-contig *** test change to surface also from gw

23.06	RCHRES	20	1
4.59	RCHRES	20	1
0.37	RCHRES	20	1

***GROUNDWATER FROM OUTSIDE OF WALKER CREEK

*** subtract sdw2 non-contig area from the 630

615.81	RCHRES	20	7
130.00	RCHRES	20	7

*** changes to contig and non-contig groundwater based on 11/19/01 analysis
 ***see walker creek 2006 model for changes to future conditions

***STREAM ROUTING

COPY 2	COPY	3	14
COPY 1	COPY	3	14
COPY 3	RCHRES	20	13
RCHRES 20	RCHRES	19	3
RCHRES 19	RCHRES	18	3

END SCHEMATIC

NETWORK

*** <MEMBER> SSYSSGAP<--MULT-->TRAN <-TARGET VOLS> <-MEMBER-> ***
 <NAME> # <NAME> TEM STRG<-FACTOR->STRG <NAME> # # <-GRP> <NAME> # # ***

END NETWORK

RCHRES

GEN-INFO	RCHRES	Name	Nexits	Unit	Systems	Printer			
# - #				User	T-series	Engl	Metr	LKFG	
				in	out				
18		Trib (0371A) M 18	1	1	1	1	62	0	0
19		Trib (0371A) M 19	1	1	1	1	62	0	0
20		Trib M 20	1	1	1	1	62	0	1
21		Trib (0371H) M 21	1	1	1	1	62	0	0
22		Trib (0371A) M 22	1	1	1	1	62	0	0

END GEN-INFO

ACTIVITY

RCHRES ***** Active Sections *****
 # - # HYFG ADFG CNFG HTFG SDFG GQFG OXFG NUFG PKFG PHFG
 1 63 1 0 0 0 0 0 0 0 0 0

END ACTIVITY

PRINT-INFO

RCHRES ***** Printout Flags ***** PIVL PYR
 # - # HYDR ADCA CONS HEAT SED GQL OXRX NUTR PLNK PHCB *****
 1 63 5 0 0 0 0 0 0 0 0 0 0 1 9

END PRINT-INFO

HYDR-PARMI

RCHRES Flags for each HYDR Section ***
 # - # VC A1 A2 A3 ODFVFG for each *** ODGTFG for each FUNCT for each
 FG FG FG FG possible exit *** possible exit possible exit

1 99 0 1 0 0 4 0 0 0 0 0 0 0 0 0 2 2 2 2 2
 END HYDR-PARM1
 HYDR-PARM2

RCHRES #	FTABNO	LEN	DELTH	STCOR	KS	DB50
18	18	0.800			0.3	
19	19	0.568			0.3	
20	20	0.379			0.3	
21	21	0.450			0.3	
22	22	0.300			0.3	

END HYDR-PARM2
 HYDR-INIT

RCHRES #	Initial VOL ac-ft	Initial COLIND for each possible exit	Initial OUTDGT for each possible exit
18	0.1	4.0	
19	0.1	4.0	
20	10.0	4.0	
21	0.1	4.0	
22	0.1	4.0	

END HYDR-INIT
 END RCHRES

FTABLES

FTABLE 18
 ROWS COLS ***
 3 4
 DEPTH AREA VOLUME OUTFLOW ***
 0.00 1.30 0.00 0.00
 1.00 1.30 1.30 166.00
 2.00 1.40 2.65 490.00
 END FTABLE 18

FTABLE 19
 ROWS COLS ***
 3 4
 DEPTH AREA VOLUME OUTFLOW ***
 0.00 1.10 0.00 0.00
 1.00 1.10 1.10 65.00
 2.00 1.20 2.25 223.00
 END FTABLE 19

FTABLE 20
 *** WALKER CREEK WETLAND
 ROWS COLS ***
 10 4
 DEPTH AREA VOLUME OUTFLOW OUTFLOW ***
 0.00 0.00 0.00 0.00
 1.00 2.50 1.25 7.04
 2.00 5.00 5.00 17.84
 3.00 12.00 13.50 32.17
 4.00 19.00 29.00 45.13
 5.00 22.00 49.50 54.95
 6.00 23.00 72.00 61.62
 6.10 23.00 74.30 62.15
 7.00 23.50 95.25 67.00
 7.24 24.10 101.10 100.00
 END FTABLE 20

FTABLE 21
 ROWS COLS ***
 8 4

DEPTH	AREA	VOLUME	OUTFLOW	***
0.000	0.0000	0.0000	0.00	
0.100	0.2259	0.0113	0.11	
0.500	0.2707	0.1106	4.27	
1.000	0.3268	0.2600	15.13	
1.500	0.3828	0.4374	31.67	
2.000	0.4389	0.6428	54.02	
2.500	0.4949	0.8763	82.52	
3.000	0.5510	1.1377	117.55	

END FTABLE 21

FTABLE 22
 ROWS COLS ***
 9 4

DEPTH	AREA	VOLUME	OUTFLOW	***
0.000	0.0000	0.0000	0.00	
0.100	0.3680	0.0184	0.25	
0.500	0.3717	0.1664	9.39	
1.000	0.3763	0.3534	31.06	
2.000	0.3819	0.7325	94.37	
3.000	0.3874	1.1171	174.33	
4.000	0.3930	1.5073	265.38	
5.000	0.3985	1.9030	364.68	
6.000	0.4040	2.3043	470.60	

END FTABLE 22
 END FTABLES

```

MASS-LINK
<Volume> <-Grp> <-Member-><--Mult--> <Target> <-Grp> <-Member->***
<Name> <Name> # #<-factor-> <Name> <Name> # #****
MASS-LINK 1
conversion from acre-inches to acre-ft (1/12) ***
PERLND PWATER PERO 0.0833333 RCHRES INFLOW IVOL
END MASS-LINK 1

MASS-LINK 2
IMPLND IWATER SURO 0.0833333 RCHRES INFLOW IVOL
END MASS-LINK 2

MASS-LINK 3
RCHRES ROFLOW RCHRES INFLOW
END MASS-LINK 3

MASS-LINK 4
RCHRES OFLOW OVOL 1 RCHRES INFLOW IVOL
END MASS-LINK 4

MASS-LINK 5
RCHRES OFLOW OVOL 2 RCHRES INFLOW IVOL
END MASS-LINK 5

MASS-LINK 6
PERLND PWATER SURO 0.0833333 RCHRES INFLOW IVOL
PERLND PWATER IFWO 0.0833333 RCHRES INFLOW IVOL
END MASS-LINK 6

MASS-LINK 7
PERLND PWATER AGWO 0.0833333 RCHRES INFLOW IVOL
END MASS-LINK 7

MASS-LINK 8
  
```

PERLND	PWATER	PERO	0.0833333	COPY	INPUT	MEAN
END MASS-LINK		8				
MASS-LINK		9				
IMPLND	IWATER	SURO	0.0833333	COPY	INPUT	MEAN
END MASS-LINK		9				
MASS-LINK		10				
PERLND	PWATER	SURO	0.0833333	COPY	INPUT	MEAN
PERLND	PWATER	IFWO	0.0833333	COPY	INPUT	MEAN
END MASS-LINK		10				
MASS-LINK		11				
PERLND	PWATER	AGWO	0.0833333	COPY	INPUT	MEAN
END MASS-LINK		11				
MASS-LINK		12				
PERLND	PWATER	AGWO	0.0833333	COPY	INPUT	MEAN
END MASS-LINK		12				
MASS-LINK		13				
COPY	OUTPUT	MEAN		RCHRES	INFLOW	IVOL
END MASS-LINK		13				
MASS-LINK		14				
COPY	OUTPUT	MEAN		COPY	INPUT	MEAN
END MASS-LINK		14				
END MASS-LINK						
END RUN						

2006 CONDITIONS

AR 020345

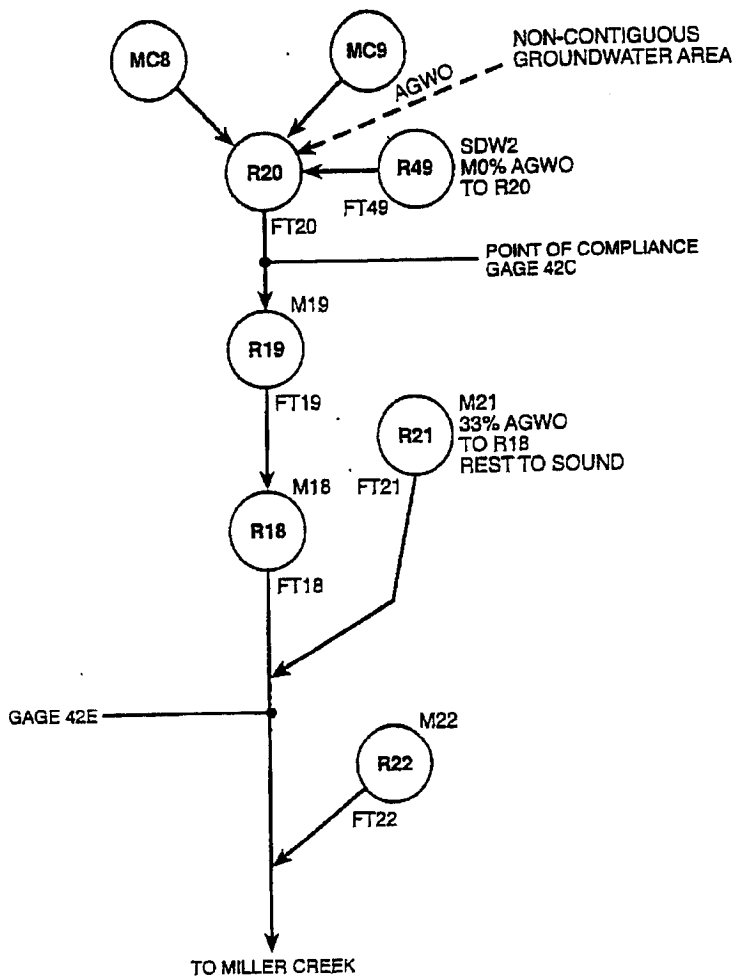

Parametrix, Inc. Port of Seattle/556-2912-001/01(288) 12/01 (K)

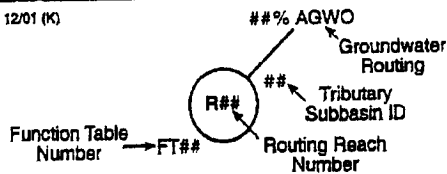

**HSPF Model Schematic
Walker Creek
Low Flow Analysis
2006 Conditions**

```

RUN
GLOBAL
*** FILE: wclowflo.inp REVISED July 2001. ATC
*** SEATAC AIRPORT HSPF BASIN MODEL OF WALKER CREEK
*** 2006 FUTURE PROJECT CONDITION SIZING BASED
*** CHANGED PREC DSN 2 TO NEW PREC DSN 1002
*** WALKER CREEK FOUR YEAR RUN USING CALIBRATION INITIAL CONDITIONS
WALKER CREEK BASIN HSPF MODEL
START      1990 10 1 0 0  END      1994 9 30 24 0

RUN INTERP OUTPUT LEVEL      3
RESUME      0 RUN      1
END GLOBAL
    
```

```

FILES
<type> <fun> ***<-----fname----->
MESSU    24  D:\PARA\SEATAC\MILLER\LOWFLOW\WALKER.MES
WDM      25  D:\PARA\SEATAC\MILLER\LOWFLOW\m1owflow.WDM
         61  D:\PARA\SEATAC\MILLER\LOWFLOW\WPER.L61
         62  D:\PARA\SEATAC\MILLER\LOWFLOW\WRCH.L62
END FILES
    
```

```

OPN SEQUENCE
INGRP                                INDELT 01:00
  PERLND      14
  PERLND      16
  PERLND      18
  PERLND      24
  PERLND      26
  PERLND      28
  PERLND      34
  PERLND      44
  PERLND      45
  PERLND      54
  PERLND      64
  PERLND      65
  PERLND      80
  IMPLND      14
  RCHRES      49
  RCHRES      20
  RCHRES      19
  RCHRES      18
END INGRP
END OPN SEQUENCE
    
```

```

COPY
TIMESERIES
Copy-opn
# - # NPT NMN
1 5 1 1
END TIMESERIES
END COPY
    
```

```

PERLND
GEN-INFO
<PLS >
# - #
Name
NBLKS Unit-systems Printer
User t-series Engl Metr
in out
14 TFF- TILL FOR FLT 1 1 1 1 61 0
16 TFM- TILL FOR MOD 1 1 1 1 61 0
18 TFS- TILL FOR STP 1 1 1 1 61 0
24 TGF- TILL GR FLT 1 1 1 1 61 0
26 TGM- TILL GR MOD 1 1 1 1 61 0
Page 1
    
```

```

28 TGS- TILL GR STP 1 1 1 1 61 0
34 OF - OUTWASH FOR 1 1 1 1 61 0
44 OG - OUTWASH GR 1 1 1 1 61 0
***PERLND FOR NEW AIRPORT FILL; NONE IN CALIBRATION
45 AIRPORT FILL 1 1 1 1 61 0
54 SA - WETLANDS 1 1 1 1 61 0
64 TGM DES MOINES 1 1 1 1 61 0
65 OG DES MOINES 1 1 1 1 61 0
80 Fill AGWO 1 1 1 1 61 0

```

END GEN-INFO

ACTIVITY

```

<PLS > ***** Active Sections *****
# - # ATMP SNOW PWAT SED PST PWG PQAL MSTL PEST NITR PHOS TRAC ***
14 200 0 0 1 0 0 0 0 0 0 0 0 0

```

END ACTIVITY

PRINT-INFO

```

<PLS > ***** Print-flags ***** PIVL PYR
# - # ATMP SNOW PWAT SED PST PWG PQAL MSTL PEST NITR PHOS TRAC *****
14 200 0 0 5 0 0 0 0 0 0 0 0 0 1 9

```

END PRINT-INFO

PWAT-PARM1

```

<PLS > ***** Flags *****
# - # CSNO RTOP UZFG VCS VUZ VNN VIFG VIRC VLE ***
14 0 0 0 0 0 0 0 0 0
16 0 0 0 0 0 0 0 0 0
18 0 0 0 0 0 0 0 0 0
24 0 0 0 0 0 0 0 0 0
26 0 0 0 0 0 0 0 0 0
28 0 0 0 0 0 0 0 0 0
34 0 0 0 0 0 0 0 0 0
44 0 0 0 0 0 0 0 0 0
45 0 0 0 0 0 0 0 0 0
54 0 0 0 0 0 0 0 0 0
64 0 0 0 0 0 0 0 0 0
80 0 0 0 0 0 0 0 0 0

```

END PWAT-PARM1

PWAT-PARM2

```

<PLS > ***
# - # ***FOREST LZSN INFILT LSUR SLSUR KVARY AGWRC
14 4.5000 0.0800 400.00 0.0500 0.5000 0.9960
16 4.5000 0.0800 400.00 0.1000 0.5000 0.9960
18 4.5000 0.0800 200.00 0.2000 0.5000 0.9960
24 4.5000 0.0300 400.00 0.0500 0.5000 0.9960
26 4.5000 0.0300 400.00 0.1000 0.5000 0.9960
28 4.5000 0.0300 200.00 0.2000 0.5000 0.9960
34 5.0000 2.0000 400.00 0.0500 0.3000 0.9960
44 5.0000 0.8000 400.00 0.0500 0.3000 0.9960
45 7.5000 0.0200 300.00 0.0700 0.0000 0.9960
54 4.0000 2.0000 100.00 0.0010 0.5000 0.9960
64 4.5000 0.1200 400.00 0.1000 0.5000 0.9990
65 5.0000 0.8000 400.00 0.0500 0.5000 0.9960
80 4.5000 0.0300 400.00 0.1000 0.5000 0.9960

```

END PWAT-PARM2

PWAT-PARM3

```

<PLS > ***
# - #*** PETMAX PETMIN INFEXP INFILD DEEPFR BASETP AGWETP
14 2.0000 2.0000 0.00 0.00 0.0
16 2.0000 2.0000 0.00 0.00 0.0
18 2.0000 2.0000 0.00 0.00 0.0
24 2.0000 2.0000 0.00 0.00 0.0
26 2.0000 2.0000 0.00 0.0 0.0
28 2.0000 2.0000 0.00 0.0 0.0
34 2.0000 2.0000 0.00 0.00 0.0

```

44	2.0000	2.0000	0.00	0.	0.
45	2.0000	2.0000	0.00	0.	0.7
54	10.000	2.0000	0.00	0.	0.0
64	2.0000	2.0000	0.00	0.	0.
80	2.0000	2.0000	0.00	0.	0.

END PWAT-PARM3
PWAT-PARM4

```

***
<PLS >
# - #          CEPSC      UZSN      NSUR      INTFW      IRC      LZETP***
14          0.2000      1.0000      0.3500      2.000      0.1500      0.7000
16          0.2000      0.5000      0.3500      2.000      0.1500      0.7000
18          0.2000      0.3000      0.3500      2.000      0.1500      0.7000
24          0.1000      0.5000      0.2500      2.000      0.1500      0.2500
26          0.1000      0.2500      0.2500      2.000      0.1500      0.2500
28          0.1000      0.1500      0.2500      2.000      0.1500      0.2500
34          0.2000      0.5000      0.3500      0.000      0.5000      0.7000
44          0.1000      0.5000      0.2500      0.000      0.5000      0.2500
45          0.1000      0.2800      0.2500      6.000      0.1500      0.6000
54          0.1000      3.0000      0.5000      1.000      0.7000      0.8000
64          0.1000      0.2500      0.2500      3.000      0.5000      0.2500
65          0.1000      0.5000      0.2500      0.000      0.5000      0.2500
80          0.1000      0.2500      0.2500      2.000      0.1500      0.2500
    
```

END PWAT-PARM4
PWAT-STATE1

```

<PLS > PWATER state variables***
# - #***      CEPS      SURS      UZS      IFWS      LZS      AGWS      GWVS
14          0.000      0.      0.0200      0.00      0.020      3.50      0.045
16          0.000      0.      0.0010      0.00      0.020      3.49      0.047
18          0.000      0.      0.0000      0.00      0.020      2.90      0.043
26          0.000      0.      0.0000      0.00      1.758      2.81      0.041
28          0.000      0.      0.0000      0.00      1.598      2.74      0.039
34          0.000      0.      0.0000      0.00      1.516      6.25      0.134
44          0.000      0.      0.0000      0.00      2.756      3.01      0.000
45          0.000      0.      0.0000      0.00      0.373      0.00      0.000
54          0.000      0.      0.3650      0.00      0.561      22.28      0.000
64          0.000      0.      0.0000      0.00      1.978      20.00      0.000
65          0.000      0.      0.0000      0.00      0.000      2.90      0.000
80          0.000      0.      0.0000      0.00      1.758      0.00      0.043
    
```

END PWAT-STATE1

END PERLND
IMPLND

```

GEN-INFO
<ILS >      Name      Unit-systems      Printer      ***
# - #      User t-series      Engl Metr      ***
# - #      in out
14      IMPERVIOUS      1 1 1      60 0
    
```

```

END GEN-INFO
ACTIVITY
<ILS > ***** Active Sections *****
# - # ATMP SNOW IWAT SLD IWG IQAL ***
14      0 0 1 0 0 0
    
```

```

END ACTIVITY
PRINT-INFO
<ILS > ***** Print-flags ***** PIVL PYR
# - # ATMP SNOW IWAT SLD IWG IQAL *****
14      0 0 6 0 0 0 1 9
    
```

```

END PRINT-INFO
IWAT-PARM1
<ILS >      Flags      ***
# - # CSNO RTOP VRS VNN RTLI      ***
14      0 0 0 0 0
    
```

END IWAT-PARM1
IWAT-PARM2

```

<ILS >
# - #      LSUR      SLSUR      NSUR      RETSC
14      100.00    0.0100    0.1000    0.1000
END IWAT-PARM2
IWAT-PARM3
<ILS >
# - #      PETMAX    PETMIN
14
END IWAT-PARM3
IWAT-STATE1
<ILS > IWATER state variables
# - #      RETS      SURS
14      1.0000E-3  1.0000E-3
END IWAT-STATE1
END IMPLND

```

EXT SOURCES

*** NOTE: The only RCHRES that precip and PET are applied to are lakes.

```

<-Volume-> <Member> Ssysgag<--Mult-->Tran <-Target vols> <-Grp> <-Member->
<Name> # <Name> # tem strg<-factor-->strg <Name> # # <Name> # #
*** PRECIP/EVAP TO PERVIOUS/IMPERV SURFACES
WDM 1002 PREC ENGLZERO 1.00 PERLND 14 65 EXTNL PREC
WDM 1002 PREC ENGLZERO 0.00 PERLND 80 EXTNL PREC
WDM 1002 PREC ENGLZERO 1.00 IMPLND 14 EXTNL PREC
WDM 1 EVAP ENGLZERO 0.8 PERLND 14 65 EXTNL PETINP
WDM 1 EVAP ENGLZERO 0.0 PERLND 80 EXTNL PETINP
WDM 1 EVAP ENGLZERO 0.8 IMPLND 14 EXTNL PETINP
*** PRECIP/EVAP TO LAKES
WDM 1002 PREC ENGLZERO RCHRES 20 EXTNL PREC
WDM 1 EVAP ENGLZERO 0.8 RCHRES 20 EXTNL POTEV
WDM 1002 PREC ENGLZERO RCHRES 49 EXTNL PREC
WDM 1 EVAP ENGLZERO 0.8 RCHRES 49 EXTNL POTEV

```

```

*** Fill flow directly to stream
*** Conversion factor from cu. ft./day to acre-ft/interval
*** divide by 43560*24
WDM 7100 FLOW ENGL .000000957 RCHRES 20 INFLOW IVOL
*** till seepage groundwater flow from fill area. PGG time series
*** conversion factor from cu. ft./day to inches
*** (1/(43560*24) * 12)/area (16.74Ac)
WDM 7101 FLOW ENGLZERO.000000686 PERLND 80 EXTNL AGWLI
*** Fill surface flow to sdw2 pond
WDM 7102 FLOW ENGL .000022957 RCHRES 49 INFLOW IVOL
END EXT SOURCES

```

EXT TARGETS

```

<-Volume-> <-Grp> <-Member-><--Mult-->Tran <-Volume-> <Member> Tsys Tgap Amd ***
<Name> # <Name> # #<-factor-->strg <Name> # <Name> tem strg strg***
RCHRES 18 HYDR RO *** WDM 7196 FLOW ENGL REPL
RCHRES 20 HYDR RO WDM 7197 FLOW ENGL REPL
***PROJECT CONDITION FLOWS
RCHRES 49 HYDR RO 1 1 *** WDM 109 FLOW ENGL REPL
*** DETENTION STAGES
RCHRES 49 HYDR STAGE *** WDM 649 STAG ENGL REPL
*** DETENTION VOLUME
RCHRES 49 HYDR VOL *** WDM 749 VOL ENGL REPL
*** 39=SR509 37=SDW2
END EXT TARGETS

```

SCHEMATIC
<-Source-->

<--Area--> <-Target--> MBLK ***
Page 4

<Name>	#	<-factor->	<Name>	#	Tbl#	***
***WALKER CREEK						
*** SUB-CATCHMENT MC 8						
PERLND	26	3.93	RCHRES	20		1
PERLND	44	18.73	RCHRES	20		1
PERLND	54	2.70	RCHRES	20		1
IMPLND	14	0.01	RCHRES	20		2
*** SUB-CATCHMENT SDW-2						
PERLND	26	26.82	RCHRES	49		6
PERLND	44	1.42	RCHRES	49		6
PERLND	45	6.70	RCHRES	49		6
PERLND	26	26.82	RCHRES	20		7
PERLND	44	1.42	RCHRES	20		7
PERLND	45	6.70	RCHRES	20		7
IMPLND	14	9.51	RCHRES	49		2
***REPLACE SUBCATCHMENT SDW-2 WITH NEW SDW-2 SUBBASIN						
***SUBBASIN SDW-2 ROUTING AS OF 4/19/01						
PERLND	26	26.88	RCHRES	49		6
PERLND	44	1.51	RCHRES	49		6
*** old fill area						
PERLND	45	6.700	RCHRES	49		6
*** area removed = 4.09 ac						
PERLND	45	2.610	RCHRES	49		6
*** old fill area						
IMPLND	14	9.51	RCHRES	49		2
*** area removed = 2.00 ac						
IMPLND	14	7.51	RCHRES	49		2
*** FILL AGWO PERLND 80 ALL TO GROUNDWATER						
PERLND	80	16.74	RCHRES	20		7
*** 10.66 ACRES OF SDS7 NOT CONTRIBUTION AND NOT INCLUDED						
*** From Miller surface flow for walker.used to be mc7b						
*** sdwlb basins						
*** cut out groundwater flow from sdw2 from fill and imp						
***ADD SDW2A AND SDW2B GROUNDWATER						
***sdw2-a						
PERLND	26	2.16	RCHRES	20		7
PERLND	44	1.51	RCHRES	20		7
PERLND	45	1.52	RCHRES	20		7
IMPLND	14	5.49	RCHRES	20		2
***sdw2-b						
PERLND	26	13.67	RCHRES	20		7
IMPLND	14	1.14	RCHRES	20		2
*** SUB-CATCHMENT MC 9						
PERLND	26	9.28	RCHRES	20		1
PERLND	44	0.76	RCHRES	20		1
IMPLND	14	0.40	RCHRES	20		2
*** SUB-CATCHMENT 18						
PERLND	16	0.76	RCHRES	18		1
PERLND	26	16.08	RCHRES	18		1
PERLND	34	20.95	RCHRES	18		1
PERLND	44	49.22	RCHRES	18		1
IMPLND	14	3.30	RCHRES	18		2
*** SUB-CATCHMENT 19						
PERLND	16	12.72	RCHRES	19		1
PERLND	26	92.07	RCHRES	19		1
PERLND	34	8.39	RCHRES	19		1
PERLND	44	95.55	RCHRES	19		1
IMPLND	14	30.53	RCHRES	19		2
*** SUB-CATCHMENT 20						
PERLND	26	12.54	RCHRES	20		1

PERLND 44	53.42	RCHRES 20	1
PERLND 54	33.43	RCHRES 20	1
IMPLND 14	52.83	RCHRES 20	2

*** DOWN STREAM OF WALKER CREEK GAGE

*** SUB-CATCHMENT 21 33% OF GW GOES TO GAGE REST GOES TO SOUND

PERLND 16	2.54	RCHRES 18	7
PERLND 26	44.30	RCHRES 18	7
PERLND 34	2.03	RCHRES 18	7
PERLND 44	41.13	RCHRES 18	7
PERLND 16	2.54	RCHRES 21	6
PERLND 26	44.30	RCHRES 21	6
PERLND 34	2.03	RCHRES 21	6
PERLND 44	41.13	RCHRES 21	6
IMPLND 14	16.54	RCHRES 21	2
PERLND 16	5.07	RCHRES 21	1
PERLND 26	88.61	RCHRES 21	1
PERLND 34	4.06	RCHRES 21	1
PERLND 44	82.26	RCHRES 21	1
IMPLND 14	33.09	RCHRES 21	2

*** SUB-CATCHMENT 22

PERLND 34	4.30	RCHRES 22	1
PERLND 44	19.49	RCHRES 22	1
PERLND 54	3.21	RCHRES 22	1
IMPLND 14	3.95	RCHRES 22	2

***GROUNDWATER FROM OUTSIDE OF WALKER CREEK

PERLND 64	615.81	RCHRES 20	7
-----------	--------	-----------	---

*** reduce non-contig pervious area based on non-contig that becomes contig below

PERLND 64 529.39 RCHRES 20 7
 *** changes to contig and non-contig groundwater based on 11/19/01 analysis

***sds7 area lost from pre to post

*** SUBTRACT 0.82 acres from perlnd 26

PERLND 26	4.32	RCHRES 20	7
PERLND 26	3.5	RCHRES 20	7
PERLND 44	3.93	RCHRES 20	7
PERLND 45	5.48	RCHRES 20	7
IMPLND 14	36.02	RCHRES 20	2

***CONTIG SDS7A

PERLND 26	0.17	RCHRES 20	1
IMPLND 14	0.13	RCHRES 20	2

***STREAM ROUTING

RCHRES 49	RCHRES 20	3
RCHRES 20	RCHRES 19	3
RCHRES 19	RCHRES 18	3

END SCHEMATIC

NETWORK

```

***      <MEMBER> SSSYSSGAP<--MULT-->TRAN <-TARGET VOL> <-MEMBER-> ***
<NAME> # <NAME> TEM STRG<-FACTOR->STRG <NAME> # # <-GRP> <NAME> # # ***
    
```

END NETWORK

RCHRES

```

GEN-INFO
RCHRES      Name      Nexits  Unit Systems  Printer      ***
. # - #<-----><-----> User T-series Engl Metr LKFG ***
              in out
    
```

FTABLE 19
 ROWS COLS ***
 3 4
 DEPTH AREA VOLUME OUTFLOW ***
 0.00 1.10 0.00 0.00
 1.00 1.10 1.10 65.00
 2.00 1.20 2.25 223.00
 END FTABLE 19

FTABLE 49
 *** PROJECT POND F SDW2
 ROWS COLS ***
 12 4
 DEPTH AREA VOLUME OUTFLOW ***
 0.000 0.8880 0.0000 0.00
 1.000 0.9270 1.0823 0.25
 2.000 0.9690 2.2096 0.35
 3.000 1.0450 3.3828 0.42
 4.000 1.0450 4.6027 0.49
 5.000 1.0860 5.8726 0.55
 6.000 1.1260 7.1935 0.60
 7.000 1.1670 8.5645 1.20
 8.000 1.2130 9.9861 2.69
 8.300 1.2560 10.454 3.09
 9.000 1.2560 11.459 7.57
 10.000 1.3000 12.987 16.88
 END FTABLE 49

FTABLE 20
 *** WALKER CREEK WETLAND
 ROWS COLS ***
 10 4
 DEPTH AREA VOLUME OUTFLOW OUTFLOW ***
 0.00 0.00 0.00 0.00
 1.00 2.50 1.25 7.04
 2.00 5.00 5.00 17.84
 3.00 12.00 13.50 32.17
 4.00 19.00 29.00 45.13
 5.00 22.00 49.50 54.95
 6.00 23.00 72.00 61.62
 6.10 23.00 74.30 62.15
 7.00 23.50 95.25 67.00
 7.24 24.10 101.10 100.00
 END FTABLE 20

FTABLE 21
 ROWS COLS ***
 8 4
 DEPTH AREA VOLUME OUTFLOW ***
 0.000 0.0000 0.0000 0.00
 0.100 0.2259 0.0113 0.11
 0.500 0.2707 0.1106 4.27
 1.000 0.3268 0.2600 15.13
 1.500 0.3828 0.4374 31.67
 2.000 0.4389 0.6428 54.02
 2.500 0.4949 0.8763 82.52
 3.000 0.5510 1.1377 117.55
 END FTABLE 21

FTABLE 22
 ROWS COLS ***
 9 4

DEPTH	AREA	VOLUME	OUTFLOW
0.000	0.0000	0.0000	0.00
0.100	0.3680	0.0184	0.25
0.500	0.3717	0.1664	9.39
1.000	0.3763	0.3534	31.06
2.000	0.3819	0.7325	94.37
3.000	0.3874	1.1171	174.33
4.000	0.3930	1.5073	265.38
5.000	0.3985	1.9030	364.68
6.000	0.4040	2.3043	470.60

END FTABLE 22

END FTABLES

MASS-LINK

<Volume>	<-Grp>	<-Member->	<--Mult-->	<Target>	<-Grp>	<-Member->	****
<Name>		<Name>	# #<-factor->	<Name>		<Name>	# #****

MASS-LINK	1					***	
		conversion from	acre-inches to acre-ft	(1/12)			
PERLND	PWATER	PERO	0.0833333	RCHRES		INFLOW	IVOL
END MASS-LINK	1						

MASS-LINK	2						
IMPLND	IWATER	SURO	0.0833333	RCHRES		INFLOW	IVOL
END MASS-LINK	2						

MASS-LINK	3						
RCHRES	ROFLOW			RCHRES		INFLOW	
END MASS-LINK	3						

MASS-LINK	4						
RCHRES	OFLOW	OVOL	1	RCHRES		INFLOW	IVOL
END MASS-LINK	4						

MASS-LINK	5						
RCHRES	OFLOW	OVOL	2	RCHRES		INFLOW	IVOL
END MASS-LINK	5						

MASS-LINK	6						
PERLND	PWATER	SURO	0.0833333	RCHRES		INFLOW	IVOL
PERLND	PWATER	IFWO	0.0833333	RCHRES		INFLOW	IVOL
END MASS-LINK	6						

MASS-LINK	7						
PERLND	PWATER	AGWO	0.0833333	RCHRES		INFLOW	IVOL
END MASS-LINK	7						

MASS-LINK	8						
PERLND	PWATER	PERO	0.0833333	COPY		INPUT	MEAN
END MASS-LINK	8						

MASS-LINK	12						
PERLND	PWATER	AGWO	0.0833333	COPY		INPUT	MEAN
END MASS-LINK	12						

MASS-LINK	9						
IMPLND	IWATER	SURO	0.0833333	COPY		INPUT	MEAN
END MASS-LINK	9						

MASS-LINK	10						
COPY	OUTPUT	MEAN		RCHRES		INFLOW	IVOL
END MASS-LINK	10						

END MASS-LINK

END RUN

HSPF INPUT FILE
(USED FOR INPUT TO THE HYDRUS/SLICE
EMBANKMENT MODELING)

AR 020356

OUTWASH

RUN GLOBAL

*** FILE: Outwash.inp Joe Brascher ATC
*** MILLER and Walker CREEK Outwash runoff generation.
WALKER CREEK BASIN HSPF MODEL
START 1983 10 1 END 1994 9 30
RUN INTERP OUTPUT LEVEL 3
RESUME 0 RUN 1
END GLOBAL

FILES
<type> <fun>***<-----fname----->
MESSU 24 D:\PARA\SEATAC\MILLER\RELOW\MILLOUT.mes
WDM 25 D:\PARA\SEATAC\MILLER\RELOW\MLOWFLOW.WDM
61 D:\PARA\SEATAC\MILLER\RELOW\MILLOUT.L61
END FILES

OPN SEQUENCE INDELT 00:60
INGRP
IMPLND 14
PERLND 44
COPY *** 1
END INGRP
END OPN SEQUENCE ***

COPY
TIMESERIES ***
Copy-opn ***
- # NPT NMN
1 5 1
END TIMESERIES
END COPY

PERLND
GEN-INFO ***
<PLS > Name NBLKS Unit-systems Printer ***
- # User t-series Engl Metr ***
in out
44 OF - OUTWASH GRA 1 1 1 1 61 0

END GEN-INFO
ACTIVITY ***
<PLS > ***** Active Sections *****
- # ATMP SNOW PWAT SED PST PWG PQAL MSTL PEST NITR PHOS TRAC
14 200 0 0 1 0 0 0 0 0 0 0 0 0

END ACTIVITY
PRINT-INFO
<PLS > ***** Print-flags ***** PIVL PYR *****
- # ATMP SNOW PWAT SED PST PWG PQAL MSTL PEST NITR PHOS TRAC
14 200 0 0 5 0 0 0 0 0 0 0 0 0 1 9

END PRINT-INFO
PWAT-PARM1
<PLS > ***** Flags *****
- # CSNO RTOP UZFG VCS VUZ VNN VIFW VIRC VLE
44 0 0 0 0 0 0 0 0 0

END PWAT-PARM1
PWAT-PARM2
<PLS > ***
- # ***FOREST LZSN INFILT LSUR SLSUR KVARV AGWRC
44 5.0000 0.8000 400.00 0.0500 0.3000 0.9960

END PWAT-PARM2
PWAT-PARM3
<PLS >***
- #*** PETMAX PETMIN INFEXP INFILD DEEPFR BASETP AGWETP
Page 1

```

                                OUTWASH
44                                2.0000  2.0000  0.00  0.00  0.0
END PWAT-PARM3
PWAT-PARM4
<PLS >
# - #      CEPSC      UZSN      NSUR      INTFW      IRC      LZETP***
44      0.1000      0.5000      0.2500      0.000      0.5000      0.2500
END PWAT-PARM4
PWAT-STATE1
<PLS > PWATER state variables***
# - #***      CEPS      SURS      UZS      IFWS      LZS      AGWS      GWVS
44      0.000      0.      0.0000      0.00      2.756      6.25      0.134
END PWAT-STATE1
END PERLND
***

IMPLND
GEN-INFO
<ILS >      Name      Unit-systems      Printer
# - #      User t-series Engl Metr
# - #      in out
14      IMPERVIOUS      1 1 1 60 0
END GEN-INFO
ACTIVITY
<ILS > ***** Active Sections ****
# - # ATMP SNOW IWAT SLD IWG IQAL ***
14      0 0 1 0 0 0
END ACTIVITY
PRINT-INFO
<ILS > ***** Print-flags ***** PIVL PYR
# - # ATMP SNOW IWAT SLD IWG IQAL *****
14      0 0 6 0 0 0 1 9
END PRINT-INFO
IWAT-PARM1
<ILS >      Flags
# - # CSNO RTOP VRS VNN RTLI ***
14      0 0 0 0 0
END IWAT-PARM1
IWAT-PARM2
<ILS >
# - #      LSUR      SLSUR      NSUR      RETSC
14      100.00      0.0100      0.1000      0.1000
END IWAT-PARM2
IWAT-PARM3
<ILS >
# - #      PETMAX      PETMIN
14
END IWAT-PARM3
IWAT-STATE1
<ILS > IWATER state variables
# - #      RETS      SURS
14      1.0000E-3 1.0000E-3
END IWAT-STATE1
END IMPLND
***

EXT SOURCES
<-Volume-> <Member> Ssyssgap<--Mult-->Tran <-Target vols> <-Grp> <-Member--> ***
<Name> # <Name> # tem strg<-factor-->strg <Name> # # <Name> # # ***
*** PRECIP/EVAP TO PERVIOUS/IMPERV SURFACES
WDM 1002 PREC ENGL 1.00 PERLND 44 EXTNL PREC
WDM 1002 PREC ENGL 1.00 IMPLND 14 EXTNL PREC
WDM 1 EVAP ENGL 0.8 PERLND 44 EXTNL PETINP
WDM 1 EVAP ENGLZERO 0.8 IMPLND 14 EXTNL PETINP
END EXT SOURCES
***

```

OUTWASH

```

EXT TARGETS
<-Volume-> <-Grp> <-Member-><--Mult-->Tran <-Volume-> <Member> Tsys Tgap Amd ***
<Name> # <Name> # #<-factor->strg <Name> # <Name> tem strg strg***
COPY 1 OUTPUT MEAN 1 1 *** WDM 6104 FLOW ENGL REPL
***converts inches of runoff to cubic inches of runoff.
PERLND 44 PWATER AGWI 6272640 WDM 6102 FLOW ENGL REPL
IMPLND 14 IWATER SURO 6272640 WDM 6103 FLOW ENGL REPL
END EXT TARGETS
    
```

```

SCHEMATIC
<-Source-> <--Area--> <-Target-> MBLK ***
<Name> # <-factor-> <Name> # Tbl# ***
IMPLND 14 *** 1.00 PERLND 44 23
PERLND 44 *** 0.714248 COPY 1 17
END SCHEMATIC
    
```

```

NETWORK
*** <MEMBER> SSSYGAP<--MULT-->TRAN <-TARGET VOL> <-MEMBER-> ***
<NAME> # <NAME> TEM STRG<-FACTOR->STRG <NAME> # # <-GRP> <NAME> # # ***
END NETWORK
    
```

```

MASS-LINK
<Volume> <-Grp> <-Member-><--Mult--> <Target> <-Grp> <-Member->***
<Name> <Name> # #<-factor-> <Name> # <Name> # ****
MASS-LINK 17
PERLND PWATER AGWI 0.0833333 COPY INPUT MEAN
END MASS-LINK 17

MASS-LINK 23
IMPLND IWATER SURO PERLND EXTNL SURLI
END MASS-LINK 23
MASS-LINK 24
IMPLND IWATER SURO PERLND EXTNL AGWLI
END MASS-LINK 24
END MASS-LINK
END RUN
    
```

**DES MOINES CREEK WATERSHED
HSPF INPUT FILES**

- 1994 CONDITIONS
- 2006 CONDITIONS

CERTIFICATE OF ENGINEER

The technical material and data for the Des Moines Creek watershed low flow-specific HSPF modeling were prepared under the supervision and direction of the undersigned, whose seal, as a professional engineer licensed to practice as such, is affixed below.



EXPIRES: 9 / 09 / 2002

Felix C. Kristanovich, Ph.D., P.E.

(affix seal here)

*Low Streamflow Analysis
STIA Master Plan Update Improvements*

*December 2001
556-2912-001(28B)*

1994 CONDITIONS

AR 020362

HSPF Model Schematic
 Des Moines Creek
 Low Flow Analysis
 1994 Conditions

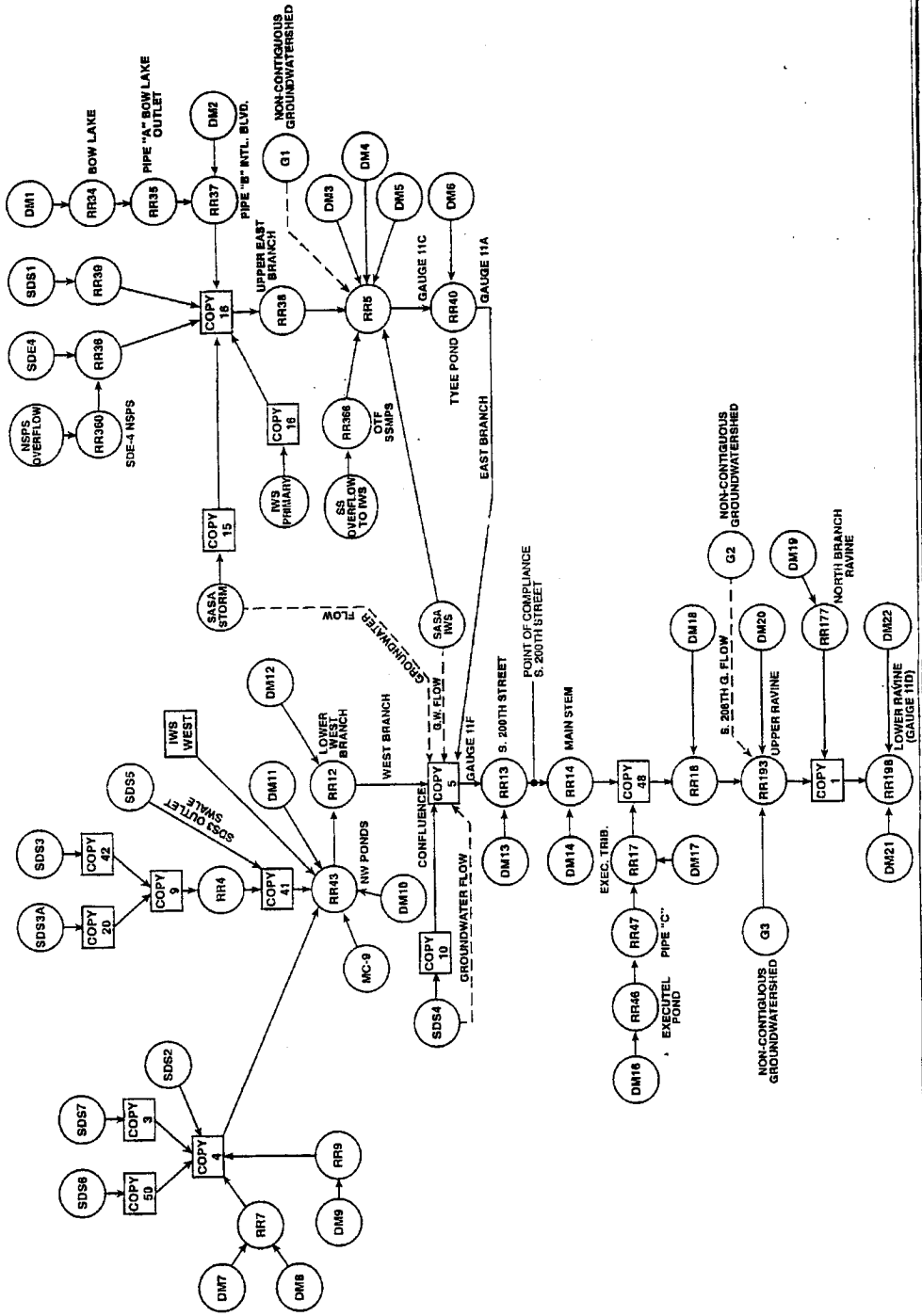

Parametrix, Inc. Part of Esri/USF: hach-1994-2012-00101288 12/01/00

- DM# = Des Moines Creek Subbasin Number
- SDS# = Storm Drainage South Number
- SDE# = Storm Drainage East Number
- RR# = Routing Reach Number (Channel or Storage Pond)

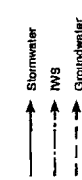

```

RUN
GLOBAL
*** FILE: DM94LOW.INP (MODIFY DMPRERSM.INP)
*** 1994 conditions low flow analysis file
*** HSPF MODEL OF DES MOINES CREEK
*** UPDATE MODEL TO CREATE DOWNSTREAM EVALUATION POINT FOR SDS TO WEST BRANCH
*** Land uses based on 1994 conditions future basins
*** Land uses adjusted as per Parametrix correspondence on 11/09/01, all other land uses adjusted to
match 1994 calibration model.
*** Groundwater routing for IWS Primary and IWS West were excluded from the model.
*** Routing schematic and all other elements are same as in the Des Moines Creek predevelopment
condition model (some WDM files are adjusted
*** to match 1994 designations)
DES MOINES CREEK BASIN HSPF MODEL
START 1948/10/01 00:00 END 1996/09/30 24:00
START 1992/01/01 00:00 END 1996/09/30 24:00***
RUN INTERP OUTPUT LEVEL 4
RESUME 0 RUN 1
END GLOBAL

```

```

FILES
MESSU 24 DM94R.MES
WDM 25 DM94RL.WDM
END FILES

```

```

OPN SEQUENCE
INGRP INDELT 01:00
PERLND 16
PERLND 26
PERLND 34
PERLND 44
PERLND 54
IMPLND 14
RCHRES 360
RCHRES 36
RCHRES 39
COPY 20
COPY 42
COPY 9
RCHRES 4
COPY 41
COPY 10
RCHRES 366
COPY 50
COPY 3
RCHRES 7
RCHRES 9
COPY 4
RCHRES 43
COPY 15
RCHRES 34
RCHRES 35
RCHRES 37
COPY 14
COPY 16
RCHRES 38
RCHRES 5
RCHRES 40
RCHRES 12
COPY 5
RCHRES 13
RCHRES 14
RCHRES 177
RCHRES 46
RCHRES 47
RCHRES 17
COPY 48
RCHRES 18
RCHRES 193
COPY 1
RCHRES 198
END INGRP
END OPN SEQUENCE

```

```

PERLND
GEN-INFO

```



```

<PLS >          Name          NBLKS  Unit-systems  Printer
# - #           User    t-series  Engr Metr
# - #           in    out
16  TEM- TILL FOR MOD          1    1    1    1    60    0
26  TGM- TILL GR MOD          1    1    1    1    60    0
34  OF - OUTWASH FOR          1    1    1    1    60    0
44  OG - OUTWASH GR          1    1    1    1    60    0
54  SA - WETLANDS             1    1    1    1    60    0

```

```

END GEN-INFO
ACTIVITY
<PLS > ***** Active Sections *****
# - # ATMP SNOW PWAT SED PST PWG PQAL MSTL PEST NITR PHOS TRAC
14  54  0  0  1  0  0  0  0  0  0  0  0  0  0

```

```

END ACTIVITY
PRINT-INFO
<PLS > ***** Print-flags ***** PIVL PYR
# - # ATMP SNOW PWAT SED PST PWG PQAL MSTL PEST NITR PHOS TRAC
14  54  0  0  6  0  0  0  0  0  0  0  0  0  1  9

```

```

END PRINT-INFO
PWAT-PARM1
<PLS > ***** Flags *****
# - # CSNO RTOP UZFG VCS VUZ VNN VIFW VIRC VLE
14  54  0  0  0  0  0  0  0  0  0  0

```

```

PWAT-PARM2
<PLS > ***
# - # ***FOREST      LZSN      INFILT      LSUR      SLSUR      KVARV      AGWRC
16          4.5000    0.2000    200.00    0.1000    0.5000    0.9960
26          4.5000    0.0750    400.00    0.1000    0.5000    0.9960
34          5.0000    2.0000    200.00    0.0500    0.3000    0.9960
44          5.0000    0.8000    200.00    0.0500    0.3000    0.9960
54          4.0000    2.0000    200.00    0.0010    0.5000    0.9960

```

```

END PWAT-PARM2
PWAT-PARM3
<PLS > ***
# - # *** PETMAX      PETMIN      INFEXP      INFILD      DEEPPFR      BASETP      AGWETP
16          2.0000    2.0000    2.0000    0.55      0.00      0.00      0.0
26          2.0000    2.0000    2.0000    0.55      0.00      0.00      0.0
34          2.0000    2.0000    2.0000    0.55      0.00      0.00      0.0
44          2.0000    2.0000    2.0000    0.55      0.00      0.00      0.0
54          10.0000   2.0000    2.0000    0.55      0.00      0.00      0.7

```

```

END PWAT-PARM3
PWAT-PARM4
<PLS >
# - #      CEPSC      UZSN      NSUR      INTFW      IRC      LZETP***
16          0.2000    0.5000    0.3500    3.000    0.5000    0.7000
26          0.1000    0.2500    0.2500    3.000    0.5000    0.2500
34          0.2000    0.5000    0.3500    0.000    0.7000    0.7000
44          0.1000    0.5000    0.2500    0.000    0.7000    0.2500
54          0.2000    3.0000    0.5000    1.000    0.7000    0.8000

```

```

END PWAT-PARM4
PWAT-STATE1
<PLS > PWATER state variables***
# - #*** CEPS      SURS      UZS      IFWS      LZS      AGWS      GWVS
16          0.078      0.      0.0010    0.      0.075    0.267    0.026
26          0.051      0.      0.0350    0.      1.928    0.680    0.049
34          0.078      0.      0.0010    0.      0.090    0.676    0.038
44          0.051      0.      0.0040    0.      1.127    0.614    0.152
54          0.051      0.      0.3330    0.      0.622    0.000    0.000

```

```

END PWAT-STATE1
END PERLND

```

```

IMPLND
GEN-INFO
<ILS >          Name          Unit-systems  Printer
# - #           User    t-series  Engr Metr
# - #           in    out
13  140 IMPERVIOUS          1    1    1    60    0
END GEN-INFO
ACTIVITY
<ILS > ***** Active Sections *****
# - # ATMP SNOW IWAT SLD IWG IQAL
13  140  0  0  1  0  0  0  0

```

```

PRINT-INFO
<ILS > ***** Print-flags ***** PIVL PYR
# - # ATMP SNOK IWAT SLD IWG IQAL *****
13 140 0 0 6 0 0 0 1 9

```

END PRINT-INFO

IWAT-PARM1

```

<ILS >
# - # CSNO RTOP VRS VNM RTLI
13 140 0 0 0 0 0

```

END IWAT-PARM1

IWAT-PARM2

```

<ILS >
# - # LSUR SLSUR RSUR RETSC
14 500.0 0.0100 0.1000 0.100
140 100.00 0.0500 0.1000 0.0500

```

END IWAT-PARM2

IWAT-PARM3

```

<ILS >
# - # PETMAX PETMIN
13 140

```

END IWAT-PARM3

IWAT-STATE1

```

<ILS > IWATER state variables
# - # RETS SURS
13 140 1.0000E-3 1.0000E-3

```

END IWAT-STATE1

END IMPLND

RCHRES

GEN-INFO

```

RCHRES Name Nexits Unit Systems Printer
# - # <-><-><-> User T-series Engr Metr LKFG
in out
4 SDS-3 Outlet Swale 1 1 1 1 0 0 0
5 E.Branch above TyeeP 1 1 1 1 0 0 0
7 DM7 & DM8 Conveyance 1 1 1 1 0 0 0
9 DM9 Conveyance 1 1 1 1 0 0 0
12 Lower W. Branch 1 1 1 1 0 0 0
13 Confl. to 200th St. 1 1 1 1 0 0 0
14 200th to Exec. Trib. 1 1 1 1 0 0 0
17 Executel Tributary 1 1 1 1 0 0 0
18 Exec.Confl. to 208th 1 1 1 1 0 0 0
34 Bow Lake 1 1 1 1 0 0 1
35 Pipe A Bow LK Outlet 1 1 1 1 0 0 0
36 SDE-4 Combined Disch 1 1 1 1 0 0 0
37 Pipe B 60" Intl Blvd 1 1 1 1 0 0 0
38 Upper E. Branch 1 1 1 1 0 0 0
39 SDS-1 Storm Only 1 1 1 1 0 0 0
40 Tyee Pond Reach 1 1 1 1 0 0 0
43 Northwest Ponds Rch 1 1 1 1 0 0 1
46 Executel Pond Reach 1 1 1 1 0 0 0
47 Pipe C Exec.Pond Dis 1 1 1 1 0 0 0
177 North Branch Ravine 1 1 1 1 0 0 0
193 Upper Ravine 1 1 1 1 0 0 0
198 Lower Ravine 1 1 1 1 0 0 0
360 SDE-4 NSPS 1 1 1 1 0 0 0
366 OTF SSMPS 1 1 1 1 0 0 0
END GEN-INFO

```

ACTIVITY

```

RCHRES ***** Active Sections *****
# - # HYFG ADFG CNFG HTFG SDFG GQFG OXFG NUFG PKFG PHFG
1 366 1 0 0 0 0 0 0 0 0 0

```

END ACTIVITY

PRINT-INFO

```

RCHRES ***** Printout Flags ***** PIVL PYR
# - # HYDR ADCA CONS HEAT SED GOL OXRX NUTR PLNK PHCB *****
1 366 6 0 0 0 0 0 0 0 0 0 1 9

```

END PRINT-INFO

HYDR-PARM1

```

RCHRES Flags for each HYDR Section
# - # VC A1 A2 A3 ODFVFG for each possible exit *** ODGTFG for each possible exit *** FUNCT for each possible exit ***
FG FG FG FG possible exit *** possible exit ***
4 17 0 1 1 0 4 0 0 0 0 0 0 0 0 0 2 2 2 2 2
18 34 0 1 1 0 4 0 0 0 0 0 0 0 0 0 2 2 2 2 2

```

```

35 42 0 1 1 0 4 0 0 0 0 0 0 0 0 0 2 2 2 2 2
43 0 1 1 0 4 5 0 0 0 0 0 0 0 0 0 2 2 2 2 2
46 198 0 1 1 0 4 0 0 0 0 0 0 0 0 0 2 2 2 2 2
360 366 0 1 1 0 4 0 0 0 0 0 0 0 0 0 2 2 2 2 2
END HYDR-PARM1

```

HYDR-PARM2
 ***Modified by FX to include 40 and 46 in the model

```

RCHRES                                     ***
# - # FTABNO LEN DELTH STCOR KS DB50     ***
-----<-----<-----<-----<-----<----->
4 4 0.530 0.3
5 5 0.380 0.3
7 7 0.341 0.3
9 9 0.189 0.3
12 12 0.273 0.3
13 13 0.218 0.3
14 14 0.213 0.3
17 17 0.246 0.3
18 18 0.303 0.3
34 34 0.208 0.3
35 35 0.123 0.3
36 1 0.100 0.3
37 37 0.381 0.3
38 38 0.142 0.3
39 1 0.100 0.3
40 40 0.189 0.3
43 43 0.189 0.3
46 46 0.047 0.3
47 47 0.417 0.3
177 177 0.407 0.3
193 193 0.795 0.3
198 198 0.631 0.3
360 1 0.100 0.3
366 1 0.100 0.3
END HYDR-PARM2

```

HYDR-INIT

```

RCHRES Initial conditions for each HYDR section ***
# - # *** VOL Initial value of COLIND Initial value of OUTDGT
*** ac-ft for each possible exit for each possible exit
-----<-----<-----<-----<-----<----->
3 0.1 4.0
4 0.1 4.0
5 0.1 4.0
7 0.1 4.0
9 0.1 4.0
12 0.1 4.0
13 0.1 4.0
14 0.1 4.0
17 0.1 4.0
18 0.1 4.0
34 35. 4.0
35 0.0 4.0
36 0.0 4.0
37 0.0 4.0
38 0.0 4.0
39 0.0 4.0
40 0.0 4.0
43 0.1 4.0 5.0
46 0.0 4.0
47 0.0 4.0
177 0.0 4.0
193 0.0 4.0
198 0.0 4.0
360 0.0 4.0
366 0.0 4.0
END HYDR-INIT
END RCHRES

```

FTABLES

```

FTABLE 1
ROWS COLS ***
8 4
DEPTH AREA VOLUME DISCH OUTFLOW2 ***

```

(FT)	(ACRES)	(AC-FT)	(CFS)	(CFS) ***
0.00	0.000	0.000	0.0	
0.50	0.016	0.006	1	
1.00	0.016	0.011	4	
1.50	0.024	0.025	12	
2.00	0.032	0.045	30	
2.50	0.040	0.070	50	
3.00	0.048	0.101	80	
3.00	0.064	0.225	250	

END FTABLE 1

FTABLE 4
 *** SDS-3 OUTLET SWALE
 ROWS COLS ***

DEPTH (FT)	AREA (ACRES)	VOLUME (ACRE-FT)	OUTFLOW (CFS)	OUTFLOW2 (CFS)
.000	.000	0.0	0.0	
.500	.198	0.1	9.0	
1.000	.236	0.5	30.9	
2.000	.306	1.0	115.8	
3.000	.376	1.5	265.5	
4.000	.446	5.0	491.8	
5.000	.517	20.0	806.3	

END FTABLE 4

FTABLE 5
 *** EAST BRANCH ABOVE TYEE POND
 ROWS COLS ***

DEPTH (FT)	AREA (ACRES)	VOLUME (ACRE-FT)	OUTFLOW (CFS)	OUTFLOW2 (CFS)
.000	.000	.000	.000	
.550	.290	.100	4.900	
1.100	.543	.200	20.800	
1.650	.609	.300	46.500	
2.200	.671	.400	60.000	
2.750	.732	0.500	118.700	
3.300	.778	0.600	159.500	
3.850	.819	0.700	198.400	
4.400	.849	0.801	231.900	
4.950	.866	1.000	252.900	
5.500	.865	1.200	253.000	
8.200	.973	1.500	400.000	
10.200	1.043	2.000	520.000	

END FTABLE 5

FTABLE 7
 *** DM7 & DM8 CONVEYANCE
 ROWS COLS ***

DEPTH (FT)	AREA (ACRES)	VOLUME (ACRE-FT)	OUTFLOW (CFS)	OUTFLOW2 (CFS)
.000	.000	.000	.000	
.500	.360	.120	6.200	
1.000	.416	.276	20.800	
2.000	.520	.694	75.400	
3.000	.626	1.252	168.700	
4.000	.732	1.950	306.900	
5.000	.836	2.790	496.100	
6.000	.942	3.768	742.300	

END FTABLE 7

FTABLE 9
 *** DM9 CONVEYANCE
 ROWS COLS ***

DEPTH (FT)	AREA (ACRES)	VOLUME (ACRE-FT)	OUTFLOW (CFS)	OUTFLOW2 (CFS)
.000	.00	0.0	.0	
.500	.20	0.7	9.7	
1.000	.23	3.1	32.6	
2.000	.29	14.9	118	
3.000	.35	38.4	265	
4.000	.41	77	482	
5.000	.47	135	778	

AR 020368

6.000 .52 214 1165
 END FTABLE 9

FTABLE 12
 *** LOWER WEST BRANCH
 *** REVISED BASED ON HEC-RAS MODEL
 ROWS COLS ***

DEPTH (FT)	AREA (ACRES)	VOLUME (ACRE-FT)	OUTFLOW (CFS)	OUTFLOW2 (CFS)
0.000	.000	0.000	.000	
.500	.291	0.030	0.150	
1.000	.346	0.260	6.600	
2.000	.450	0.430	14.100	
3.000	.554	0.650	25.000	
4.000	.656	1.180	50.000	
5.000	.753	2.170	75.000	
6.000	.796	3.820	100.000	
7.000	.837	8.820	150.000	
8.000	.837	16.200	200.000	
9.000	.837	27.920	250.000	
10.000	.837	33.530	350.000	
11.000	.837	35.380	450.000	

END FTABLE 12

FTABLE 13
 *** CONFLUENCE TO 200TH STREET
 ROWS COLS ***

DEPTH (FT)	AREA (ACRES)	VOLUME (ACRE-FT)	OUTFLOW (CFS)	OUTFLOW2 (CFS)
0.000	.000	.000	.000	
.500	.152	.051	4.300	
1.000	.272	.132	14.400	
2.000	.317	.312	50.400	
3.000	.360	.544	109.600	
4.000	.404	.826	195.000	
5.000	.450	1.163	309.500	
6.000	.497	1.548	456.300	
7.000	.542	1.984	638.000	

END FTABLE 13

FTABLE 14
 *** 200TH STREET TO EXECUTEL TRIBUTARY
 *** REACH 190 FROM TR-20/KING COUNTY BASIN PLAN MODEL:
 ROWS COLS ***

DEPTH (FT)	AREA (ACRES)	VOLUME (ACRE-FT)	OUTFLOW (CFS)	OUTFLOW2 (CFS)
0.000	0.000	0.000	0.000	
0.900	0.70	0.4000	30.00	
1.800	0.80	1.1000	115.60	
2.700	1.10	2.1000	269.80	
4.200	1.30	4.3000	707.10	

END FTABLE 14

FTABLE 17
 *** EXECUTEL TRIBUTARY
 ROWS COLS ***

DEPTH (FT)	AREA (ACRES)	VOLUME (ACRE-FT)	OUTFLOW (CFS)	OUTFLOW2 (CFS)
0.000	.000	.000	.000	
.300	.169	.034	2.900	
.600	.192	.076	9.800	
.900	.215	.128	20.400	
1.200	.238	.189	35.100	
1.500	.259	.258	54.100	
1.800	.282	.336	77.700	
2.100	.303	.423	106.200	
3.100	.376	.779	245.000	
3.600	.412	.988	335.000	

END FTABLE 17

FTABLE 18
 *** CONFLUENCE WITH EXECUTEL TRIBUTARY TO 208TH STREET

*** REPRESENTS GW LOSS IN WETLAND BELOW 200TH
 ROWS COLS ***

DEPTH (FT)	AREA (ACRES)	VOLUME (ACRE-FT)	OUTFLOW (CFS)	OUTFLOW2 (CFS)
.000	.000	.000	.000	0.00
.500	.572	.191	7.300	0.00
1.000	.799	.438	10.000	0.00
2.000	.968	1.001	20.700	0.00
3.000	1.155	1.727	100.000	0.00
4.000	1.317	2.542	262.700	0.00
5.000	1.478	3.475	400.300	0.00
6.000	1.643	4.545	570.200	0.00
7.000	1.791	5.688	774.400	0.00
8.000	1.932	6.822	1015.100	0.00
9.000	1.945	7.025	1294.500	0.00
10.000	1.958	7.244	1614.500	0.00
11.000	1.970	7.481	1977.000	0.00
12.000	1.983	7.734	2384.700	0.00

END FTABLE 15

FTABLE 34
 *** BOW LAKE
 *** BASED ON ENTRANCE CONTROL FOR 36 INCH OUTLET PIPE
 ROWS COLS ***

DEPTH (FT)	AREA (ACRES)	VOLUME (ACRE-FT)	OUTFLOW (CFS)	OUTFLOW2 (CFS)
0.000	14.000	0.000	0.000	0.00
1.000	14.000	14.000	7.000	0.00
1.500	14.000	21.000	13.000	0.00
2.000	14.000	28.000	17.000	0.00
3.000	14.000	42.000	35.000	0.00
4.000	14.000	56.000	49.000	0.00
5.000	14.000	70.000	60.000	0.00
6.000	14.000	84.000	70.000	0.00

END FTABLE 34

FTABLE 35
 *** 36" BOW LAKE DISCHARGE PIPELINE (A)
 ROWS COLS ***

DEPTH (FT)	AREA (ACRES)	VOLUME (ACRE-FT)	OUTFLOW (CFS)	OUTFLOW2 (CFS)
.000	.000	.000	.000	
.300	.020	.0006	1.000	
.600	.026	.0026	4.200	
.900	.032	.0068	9.400	
1.200	.034	.0134	16.200	
1.500	.037	.0226	24.000	
1.800	.039	.0346	32.300	
2.100	.040	.0492	40.100	
2.400	.040	.0667	46.900	
2.700	.039	.0857	51.200	
3.000	.037	.1000	55.300	
*** SURCHARGING-				
3.300	.038	.2500	60.300	
4.000	.038	.4000	90.000	
5.000	.038	.6000	100.000	
6.000	.038	1.0000	150.000	
10.000	.038	10.0000	300.000	

END FTABLE 35

FTABLE 37
 *** 60" INTERNATIONAL BLVD PIPELINE (B)
 ROWS COLS ***

DEPTH (FT)	AREA (ACRES)	VOLUME (ACRE-FT)	OUTFLOW (CFS)	OUTFLOW2 (CFS)
.000	.000	.000	.000	
.450	.134	.045	4.800	
.900	.190	.100	20.300	
1.350	.225	.150	45.400	
1.800	.249	.200	78.000	
2.250	.266	.250	115.900	
2.700	.271	.300	155.800	

3.150	.264	.350	193.800
3.600	.251	.400	226.500
4.050	.238	.450	247.000
4.500	.234	.500	247.100
6.500	.185	.600	340.000
8.500	.166	.700	415.000

END FTABLE 37

FTABLE 38
 *** UPPER EAST BRANCH
 ROWS COLS ***

9	4				
***	DEPTH	AREA	VOLUME	OUTFLOW	OUTFLOW2
	(FT)	(ACRES)	(ACRE-FT)	(CFS)	(CFS)
	.000	.000	.000	.000	
	.500	.176	.100	9.200	
	1.000	.194	0.150	30.400	
	2.000	.232	0.200	105.800	
	3.000	.271	0.250	228.900	
	4.000	.310	0.350	405.800	
	5.000	.349	0.450	642.700	
	6.000	.387	0.600	945.700	
	7.000	.426	0.800	1320.700	

END FTABLE 38

FTABLE 40
 *** TYEE POND
 *** BASED ON TYEE POND AS-BUILTS AND AUTOMATED GATE OPERATION MANUAL
 *** K RITLAND 2/4/98
 *** Inserted by EK to reflect KC comments (03/22/2001)
 ROWS COLS ***

20	4				
***	DEPTH	AREA	VOLUME	OUTFLOW	OUTFLOW2
	(FT)	(ACRES)	(ACRE-FT)	(CFS)	(CFS)
	0.00	0.00	0.00	0.00	
	0.90	0.01	0.01	10.00	
	1.65	0.02	0.02	20.00	
	3.11	0.07	0.07	30.00	
	4.56	0.22	0.29	40.00	
	6.02	0.63	0.89	50.00	
	7.48	0.88	2.02	60.00	
	8.62	1.06	3.18	70.00	
	9.79	1.18	4.29	80.00	
	10.88	1.34	5.83	90.00	
	11.99	1.48	7.20	100.00	
	13.12	1.69	9.17	110.00	
	15.13	2.04	12.90	120.00	
	16.10	2.20	14.92	124.10	
	16.30	2.24	15.40	129.65	
	16.57	2.28	15.88	150.36	
	16.64	2.32	16.36	155.00	
	16.80	2.36	16.84	208.74	
	17.03	2.40	17.32	293.59	
	17.26	2.43	17.79	428.11	

END FTABLE 40

FTABLE 43
 *** NORTHWEST PONDS
 *** BASED ON KING COUNTY BASIN PLANNING MODEL
 ROWS COLS ***

17	5				
***	DEPTH	AREA	VOLUME	OUTFLOW	OUTFLOW2
	(FT)	(ACRES)	(ACRE-FT)	(CFS)	(CFS)
	0.000	12.000	0.000	0.000	0.00
	0.100	12.000	18.800	0.000	0.00
	1.000	12.000	24.000	0.200	0.00
	2.000	12.000	30.000	0.500	0.00
	3.000	12.000	37.000	1.000	0.00
	3.500	13.000	41.000	5.000	0.00
	4.000	13.000	45.700	15.000	0.00
	4.500	13.000	51.000	35.000	0.00
	5.000	14.000	56.500	150.000	0.00
	5.500	14.000	62.800	200.000	0.00
	6.000	14.000	69.000	300.000	0.00
	6.500	14.000	83.500	350.000	0.00
	7.000	15.000	99.900	400.000	0.00

8.000	17.000	119.00	500.000	0.00
9.000	20.000	141.50	550.000	0.00
10.000	23.000	180.00	600.000	0.00
11.000	27.000	200.00	650.000	0.00

END FTABLE 43

FTABLE 46
 *** EXECUTEL POND
 ***Inserted by FK to reflect KC comments (03/22/2001)
 ROWS COLS ***

20	4				
***	DEPTH	AREA	VOLUME	OUTFLOW	OUTFLOW2
	(FT)	(ACRES)	(ACRE-FT)	(CFS)	(CFS)
	.000	.000	.000	.000	
	1.000	.080	.080	24.420	
	2.000	.230	.310	34.540	
	3.000	.393	.703	42.300	
	3.500	.494	.950	45.690	
	4.000	.508	1.204	48.850	
	4.500	.532	1.470	51.810	
	5.000	.540	1.740	54.610	
	5.500	.540	2.010	57.280	
	6.000	.580	2.300	59.820	
	6.500	.600	2.600	62.270	
	7.000	.600	2.900	64.620	
	7.500	.600	3.200	66.900	
	8.000	.620	3.510	69.100	
	8.500	.640	3.830	71.200	
	9.000	.740	4.200	82.220	
	10.000	.650	4.850	119.830	
	11.000	.720	5.570	159.000	
	12.000	.750	6.320	250.900	
	13.000	1.000	7.320	500.900	

END FTABLE 46

FTABLE 47
 ***** EXECUTEL POND DISCHARGE PIPELINE (C)
 ROWS COLS ***

11	4				
***	DEPTH	AREA	VOLUME	OUTFLOW	OUTFLOW2
	(FT)	(ACRES)	(ACRE-FT)	(CFS)	(CFS)
	.000	.000	.000	.000	
	.350	.069	.020	4.600	
	.700	.096	.056	19.200	
	1.050	.112	.099	42.800	
	1.400	.124	.150	73.400	
	1.750	.125	.203	109.000	
	2.100	.121	.240	146.600	
	2.450	.110	.264	182.400	
	2.800	.096	.284	213.200	
	3.150	.090	.290	232.400	
	3.500	.088	.293	232.600	

END FTABLE 47

FTABLE 177
 *** NORTH BRANCH RAVINE
 ROWS COLS ***

14	4				
***	DEPTH	AREA	VOLUME	OUTFLOW	OUTFLOW2
	(FT)	(ACRES)	(ACRE-FT)	(CFS)	(CFS)
	.000	.000	.000	.0	
	.500	.572	.191	7.3	
	1.000	.799	.438	23.2	
	2.000	.968	1.001	75.7	
	3.000	1.155	1.727	155.1	
	4.000	1.317	2.542	262.7	
	5.000	1.478	3.475	400.3	
	6.000	1.643	4.545	570.2	
	7.000	1.791	5.688	774.4	
	8.000	1.932	6.822	1015.1	
	9.000	1.945	7.025	1294.5	
	10.000	1.958	7.244	1614.5	
	11.000	1.970	7.481	1977.0	
	12.000	1.983	7.734	2384.7	

END FTABLE177

FTABLE 193
 *** UPPER RAVINE
 ROWS COLS ***
 14 4

DEPTH (FT)	AREA (ACRES)	VOLUME (ACRE-FT)	OUTFLOW (CFS)	OUTFLOW2 (CFS)
0.00	0.00	0.00	0.0	
0.35	0.72	0.75	7.8	
0.70	0.72	2.51	23.5	
1.05	0.72	2.28	44.3	
1.40	0.72	3.03	68.2	
1.75	0.72	3.81	95.8	
2.10	0.72	4.56	125.2	
2.45	0.75	5.36	169.0	
2.80	0.89	6.20	171.5	
3.15	1.00	7.35	247.6	
3.50	1.08	8.49	332.7	
3.85	1.21	9.75	396.5	
4.20	1.32	11.13	521.2	
4.55	1.41	12.60	655.5	

END FTABLE193

FTABLE 198
 ROWS COLS ***
 *** LOWER RAVINE
 *** ROUGH ESTIMATE BASED ON FIELD VISIT OF 12/20/95
 *** FLOW WAS 6 TO 7 CFS WITH DEPTH OF 8"
 *** NEAR OUTLET.
 *** DRIVE WHICH REPRESENTS A RESTRICTION ACCORDING TO OBSERVATION

DEPTH (FT)	AREA (ACRES)	VOLUME (ACRE-FT)	OUTFLOW (CFS)	OUTFLOW2 (CFS)
0.00	0.00	0.00	0.0	
1.00	0.50	0.80	10.0	
2.00	0.55	1.30	25.0	
3.00	0.60	1.80	50.0	
5.00	0.70	2.50	100.0	
** SUBMERGENCE OF CULVERT				
10.00	2.50	12.00	245.0	
*** OVERBANK STORAGE				
*** FLOWS BASED ON 243', .03 D-W FACTOR, PLUS LOSS OF 1. VELOCITY HEAD				
15.00	10.00	40.00	225.0	
20.00	11.00	90.00	390.0	

END FTABLE198

END FTABLES

COPY
 TIMESERIES
 Copy-opn
 # - # NPT NMN
 1 59 1
 END TIMESERIES
 END COPY

EXT SOURCES
 <-Volume-> <Member> SsysSgap<--Mult-->Tran <-Target vols> <-Grp> <-Member-> ***
 <Name> # <Name> # tem strg<-factor->strg <Name> # # <Name> # # ***
 WDM 2 PREC ENGLZERO PERLND 14 54 EXTNL PREC
 WDM 2 PREC ENGLZERO IMPLND 14 EXTNL PREC
 WDM 2 PREC ENGLZERO RCHRES 34 EXTNL PREC
 WDM 2 PREC ENGLZERO RCHRES 40 EXTNL PREC
 WDM 2 PREC ENGLZERO RCHRES 43 EXTNL PREC
 WDM 1 EVAP ENGLZERO 0.8 PERLND 14 440 EXTNL PETINP
 WDM 1 EVAP ENGLZERO 0.8 IMPLND 14 140 EXTNL PETINP
 WDM 1 EVAP ENGLZERO 0.8 RCHRES 34 EXTNL POTEV
 WDM 1 EVAP ENGLZERO 0.8 RCHRES 43 EXTNL POTEV
 WDM 1 EVAP ENGLZERO 0.8 RCHRES 40 EXTNL POTEV
 END EXT SOURCES

EXT TARGETS
 <-Volume-> <-Grp> <-Member-><--Mult-->Tran <-Volume-> <Member> Tsys Tgap Amd ***
 lame> # <Name> # #<-factor->strg <Name> # <Name> tem strg strg***

 *** SDS

```

*** SDE-4 (TOTAL)
RCHRES 36 HYDR RO WDM 21 FLOW ENGL REPL
*****
** SDS-1 (TOTAL)
RCHRES 39 HYDR RO WDM 22 FLOW ENGL REPL
*****
*** SDS-3
COPY 42 OUTPUT MEAN 1 12.1 WDM 23 FLOW ENGL REPL
*****
*** SDS-4
COPY 10 OUTPUT MEAN 1 12.1 WDM 28 FLOW ENGL REPL
*****
*** SDS-3A TAXIWAY VAULT
COPY 20 OUTPUT MEAN 1 12.1 WDM 24 FLOW ENGL REPL
*****
*** SDS-7 3RD RUNWAY VAULT
COPY 3 OUTPUT MEAN 1 12.1 WDM 26 FLOW ENGL REPL
*****

```

```

*** WEST BRANCH
*****
*** NORTHWEST PONDS REACH
RCHRES 43 HYDR RO WDM 31 FLOW ENGL REPL
*****
*** LOWER WEST BRANCH
RCHRES 12 HYDR RO WDM 35 FLOW ENGL REPL
*****
*** EVALUATION POINT FOR SDS DISCHARGE TO WEST BRANCH - POC-1
COPY 41 OUTPUT MEAN 1 12.1 WDM 160 FLOW ENGL REPL
*****
*** EVALUATION POINT FOR SDS DISCHARGE TO WEST BRANCH - POC-2
COPY 4 OUTPUT MEAN 1 12.1 WDM 161 FLOW ENGL REPL
*****

```

```

*** EAST BRANCH
*****
*** BOW LAKE OUTFLOW
RCHRES 35 HYDR RO WDM 136 FLOW ENGL REPL
RCHRES 37 HYDR RO WDM 47 FLOW ENGL REPL
*** SASA POC
COPY 16 OUTPUT MEAN 1 12.1 WDM 438 FLOW ENGL REPL
*****

```

```

*** EXISTING UPPER EAST BRANCH (FUTURE SASA DETENTION SITE)
RCHRES 38 HYDR RO WDM 37 FLOW ENGL REPL
*****
*** TYEE INFLOW (GAUGE 11C)
RCHRES 5 HYDR RO WDM 38 FLOW ENGL REPL
*****

```

```

*** MAIN STEM
*****
*** BELOW CONFLUENCE AT TYEE GOLF COURSE WEIR (GAUGE 11F)
COPY 5 OUTPUT MEAN 1 12.1 WDM 40 FLOW ENGL REPL
*****
*** BELOW CONFLUENCE AT SOUTH 200TH STREET
RCHRES 13 HYDR RO WDM 41 FLOW ENGL REPL
*****
*** LOWER DES MOINES CREEK NEAR MOUTH (GAUGE 11D)
RCHRES 198 HYDR RO WDM 42 FLOW ENGL REPL
*****

```

END EXT TARGETS

```

NETWORK
*** <MEMBER> SSYSSGAP<--MULT-->TRAN <-TARGET VOLS> <-MEMBER->
<NAME> # <NAME> TEM STRG<-FACTOR->STRG <NAME> # # <-GRP> <NAME> # # ***
*****
*** AIRPORT SUBBASINS
***** (DM23) SDE-4
PERLND 26 PWATER SURO 4.229 RCHRES 36 EXTNL IVOL
TRLND 26 PWATER IFWO 4.229 RCHRES 36 EXTNL IVOL
LRLND 26 PWATER AGWO 0.142 RCHRES 36 EXTNL IVOL
IMPLND 14 IWATER SURO 9.624 RCHRES 36 EXTNL IVOL
*****

```

```

*** (DM24) SDS-1
PERLND 26 PWATER SURO      0.077    RCHRES 39    EXTNL IVOL
RRLND 26 PWATER IFWO      0.077    RCHRES 39    EXTNL IVOL
LRLND 26 PWATER AGWO      0.072    RCHRES 39    EXTNL IVOL
IMPLND 14 IWATER SURO      1.401    RCHRES 39    EXTNL IVOL
*****

*** (DM25) SDS-3A
PERLND 26 PWATER SURO      5.227    COPY 20    INPUT MEAN 1
PERLND 26 PWATER IFWO      5.227    COPY 20    INPUT MEAN 1
IMPLND 14 IWATER SURO      0.588    COPY 20    INPUT MEAN 1
*****

*** (DM25) SDS-7
PERLND 26 PWATER SURO      6.522    COPY 3     INPUT MEAN 1
PERLND 26 PWATER IFWO      6.522    COPY 3     INPUT MEAN 1
PERLND 44 PWATER SURO      0.383    COPY 3     INPUT MEAN 1
PERLND 44 PWATER IFWO      0.383    COPY 3     INPUT MEAN 1
PERLND 54 PWATER SURO      0.033    COPY 3     INPUT MEAN 1
PERLND 54 PWATER IFWO      0.033    COPY 3     INPUT MEAN 1
IMPLND 14 IWATER SURO      0.668    COPY 3     INPUT MEAN 1
*****

*** (DM25) SDS-3
PERLND 26 PWATER SURO      13.791   COPY 42    INPUT MEAN 1
PERLND 26 PWATER IFWO      13.791   COPY 42    INPUT MEAN 1
PERLND 26 PWATER AGWO      0.288    COPY 42    INPUT MEAN 1
IMPLND 14 IWATER SURO      14.816   COPY 42    INPUT MEAN 1
*****

*** (New watershed SDS-6)
PERLND 26 PWATER SURO      1.038    COPY 50    INPUT MEAN 1
PERLND 26 PWATER IFWO      1.038    COPY 50    INPUT MEAN 1
PERLND 26 PWATER AGWO      0.148    COPY 50    INPUT MEAN 1
IMPLND 14 IWATER SURO      0.356    COPY 50    INPUT MEAN 1
*****

*** (New watershed SDS-5)
PERLND 26 PWATER SURO      2.672    COPY 41    INPUT MEAN 1
PERLND 26 PWATER IFWO      2.672    COPY 41    INPUT MEAN 1
PERLND 26 PWATER AGWO      0.878    COPY 41    INPUT MEAN 1
IMPLND 14 IWATER SURO      0.032    COPY 41    INPUT MEAN 1
*****

** (New watershed SDS-2)
PERLND 16 PWATER SURO      0.230    COPY 4     INPUT MEAN 1
PERLND 16 PWATER IFWO      0.230    COPY 4     INPUT MEAN 1
PERLND 16 PWATER AGWO      0.230    COPY 4     INPUT MEAN 1
PERLND 26 PWATER SURO      0.014    COPY 4     INPUT MEAN 1
PERLND 26 PWATER IFWO      0.014    COPY 4     INPUT MEAN 1
PERLND 26 PWATER AGWO      0.014    COPY 4     INPUT MEAN 1
PERLND 34 PWATER SURO      0.338    COPY 4     INPUT MEAN 1
PERLND 34 PWATER IFWO      0.338    COPY 4     INPUT MEAN 1
PERLND 34 PWATER AGWO      0.338    COPY 4     INPUT MEAN 1
PERLND 44 PWATER SURO      0.012    COPY 4     INPUT MEAN 1
PERLND 44 PWATER IFWO      0.012    COPY 4     INPUT MEAN 1
PERLND 44 PWATER AGWO      0.012    COPY 4     INPUT MEAN 1
PERLND 54 PWATER SURO      0.043    COPY 4     INPUT MEAN 1
PERLND 54 PWATER IFWO      0.043    COPY 4     INPUT MEAN 1
PERLND 54 PWATER AGWO      0.043    COPY 4     INPUT MEAN 1
IMPLND 14 IWATER SURO      0.124    COPY 4     INPUT MEAN 1
*****

*** (DM27) SDS-4
PERLND 16 PWATER SURO      *****  COPY 10    INPUT MEAN 1
PERLND 16 PWATER IFWO      *****  COPY 10    INPUT MEAN 1
PERLND 16 PWATER AGWO      *****  COPY 5     INPUT MEAN 1
PERLND 26 PWATER SURO      0.761    COPY 10    INPUT MEAN 1
PERLND 26 PWATER IFWO      0.761    COPY 10    INPUT MEAN 1
PERLND 26 PWATER AGWO      0.761    COPY 5     INPUT MEAN 1
PERLND 34 PWATER SURO      0.011    COPY 10    INPUT MEAN 1
PERLND 34 PWATER IFWO      0.011    COPY 10    INPUT MEAN 1
PERLND 34 PWATER AGWO      0.011    COPY 5     INPUT MEAN 1
PERLND 44 PWATER SURO      3.009    COPY 10    INPUT MEAN 1
PERLND 44 PWATER IFWO      3.009    COPY 10    INPUT MEAN 1
PERLND 44 PWATER AGWO      3.009    COPY 5     INPUT MEAN 1
IMPLND 14 IWATER SURO      1.599    COPY 10    INPUT MEAN 1
*****

*** SASA STORM
RRLND 16 PWATER SURO      1.899    COPY 15    INPUT MEAN 1
LRLND 16 PWATER IFWO      1.899    COPY 15    INPUT MEAN 1
PERLND 16 PWATER AGWO      1.899    COPY 5     INPUT MEAN 1

```

PERLND	26	PWATER	SURO	0.146	COPY	15	INPUT	MEAN	1
PERLND	26	PWATER	IFWO	0.146	COPY	15	INPUT	MEAN	1
PERLND	26	PWATER	AGWO	0.146	COPY	5	INPUT	MEAN	1
PERLND	34	PWATER	SURO	0.319	COPY	15	INPUT	MEAN	1
PERLND	34	PWATER	IFWO	0.019	COPY	15	INPUT	MEAN	1
PERLND	34	PWATER	AGWO	0.019	COPY	5	INPUT	MEAN	1
PERLND	44	PWATER	SURO	0.001	COPY	15	INPUT	MEAN	1
PERLND	44	PWATER	IFWO	0.001	COPY	15	INPUT	MEAN	1
PERLND	44	PWATER	AGWO	0.001	COPY	5	INPUT	MEAN	1
PERLND	54	PWATER	SURO	0.045	COPY	15	INPUT	MEAN	1
PERLND	54	PWATER	IFWO	0.045	COPY	15	INPUT	MEAN	1
PERLND	54	PWATER	AGWO	0.045	COPY	5	INPUT	MEAN	1
IMPLND	14	IWATER	SURO	0.745	COPY	15	INPUT	MEAN	1

*** IWS SYSTEM PRIMARY SYSTEM AND PUMP STATIONS

*** I-3: NORTH SATELLITE PUMP STATION (NSPS) TO IWS

*** OVERFLOW TO SDE-4

*** INSTALLED IN 1995

PERLND	16	PWATER	SURO	*****	RCHRES	360	EXTNL	IVOL	
PERLND	16	PWATER	IFWO	*****	RCHRES	360	EXTNL	IVOL	
PERLND	26	PWATER	SURO	0.026	RCHRES	360	EXTNL	IVOL	
PERLND	26	PWATER	IFWO	0.026	RCHRES	360	EXTNL	IVOL	
IMPLND	14	IWATER	SURO	1.120	RCHRES	360	EXTNL	IVOL	

*** I-5: SOUTH SNOWMELT (OLYMPIC TANK FARM) PUMP STATION TO IWS

*** OVERFLOW TO DES MOINES EAST BRANCH

*** INSTALLED IN LATE 1997/1998***areas not changed

IMPLND	14	IWATER	SURO	0.001	RCHRES	366	EXTNL	IVOL	
--------	----	--------	------	-------	--------	-----	-------	------	--

*** I-7: IWS - PRIMARY

PERLND	16	PWATER	SURO	*****	COPY	14	INPUT	MEAN	1
PERLND	16	PWATER	IFWO	*****	COPY	14	INPUT	MEAN	1
PERLND	26	PWATER	SURO	1.117	COPY	14	INPUT	MEAN	1
PERLND	26	PWATER	IFWO	1.117	COPY	14	INPUT	MEAN	1
PERLND	26	PWATER	AGWO	0.115	COPY	14	INPUT	MEAN	1
IMPLND	14	IWATER	SURO	19.456	COPY	14	INPUT	MEAN	1

*** SASA IWS

PERLND	16	PWATER	SURO	3.047	RCHRES	5	EXTNL	IVOL	
PERLND	16	PWATER	IFWO	3.047	RCHRES	5	EXTNL	IVOL	
PERLND	16	PWATER	AGWO	3.047	COPY	5	INPUT	MEAN	1
PERLND	26	PWATER	SURO	0.837	RCHRES	5	EXTNL	IVOL	
PERLND	26	PWATER	IFWO	0.837	RCHRES	5	EXTNL	IVOL	
PERLND	26	PWATER	AGWO	0.837	COPY	5	INPUT	MEAN	1
PERLND	34	PWATER	SURO	0.020	RCHRES	5	EXTNL	IVOL	
PERLND	34	PWATER	IFWO	0.020	RCHRES	5	EXTNL	IVOL	
PERLND	34	PWATER	AGWO	0.020	COPY	5	INPUT	MEAN	1
PERLND	44	PWATER	SURO	0.302	RCHRES	5	EXTNL	IVOL	
PERLND	44	PWATER	IFWO	0.302	RCHRES	5	EXTNL	IVOL	
PERLND	44	PWATER	AGWO	0.302	COPY	5	INPUT	MEAN	1
PERLND	54	PWATER	SURO	0.113	RCHRES	5	EXTNL	IVOL	
PERLND	54	PWATER	IFWO	0.113	RCHRES	5	EXTNL	IVOL	
PERLND	54	PWATER	AGWO	0.113	COPY	5	INPUT	MEAN	1
IMPLND	14	IWATER	SURO	0.548	RCHRES	5	EXTNL	IVOL	

*** IWS WEST

PERLND	16	PWATER	SURO	0.222	RCHRES	43	EXTNL	IVOL	
PERLND	16	PWATER	IFWO	0.222	RCHRES	43	EXTNL	IVOL	
PERLND	16	PWATER	AGWO	0.222	RCHRES	43	EXTNL	IVOL	
PERLND	26	PWATER	SURO	0.226	RCHRES	43	EXTNL	IVOL	
PERLND	26	PWATER	IFWO	0.226	RCHRES	43	EXTNL	IVOL	
PERLND	26	PWATER	AGWO	0.091	RCHRES	43	EXTNL	IVOL	
PERLND	34	PWATER	SURO	0.512	RCHRES	43	EXTNL	IVOL	
PERLND	34	PWATER	IFWO	0.512	RCHRES	43	EXTNL	IVOL	
PERLND	34	PWATER	AGWO	0.512	RCHRES	43	EXTNL	IVOL	
IMPLND	14	IWATER	SURO	0.037	RCHRES	43	EXTNL	IVOL	

*** MC-9 GW added (from Miller Creek)

PERLND	26	PWATER	AGWO	0.005	RCHRES	43	EXTNL	IVOL	
--------	----	--------	------	-------	--------	----	-------	------	--

** EAST BRANCH OF CREEK

AR 020376

```

*** DM1
PERLND 16 PWATER SURO      0.860    RCHRES 34    EXTNL IVOL
      RLND 16 PWATER IFWO      0.860    RCHRES 34    EXTNL IVOL
PERLND 16 PWATER AGWO      0.238    RCHRES 34    EXTNL IVOL
PERLND 26 PWATER SURO     11.078    RCHRES 34    EXTNL IVOL
PERLND 26 PWATER IFWO     11.078    RCHRES 34    EXTNL IVOL
PERLND 26 PWATER AGWO      2.069    RCHRES 34    EXTNL IVOL
PERLND 34 PWATER SURO      0.599    RCHRES 34    EXTNL IVOL
PERLND 34 PWATER IFWO      0.599    RCHRES 34    EXTNL IVOL
PERLND 34 PWATER AGWO      0.166    RCHRES 34    EXTNL IVOL
PERLND 44 PWATER SURO      7.697    RCHRES 34    EXTNL IVOL
PERLND 44 PWATER IFWO      7.697    RCHRES 34    EXTNL IVOL
PERLND 44 PWATER AGWO      2.132    RCHRES 34    EXTNL IVOL
PERLND 54 PWATER SURO      1.176    RCHRES 34    EXTNL IVOL
PERLND 54 PWATER IFWO      1.176    RCHRES 34    EXTNL IVOL
PERLND 54 PWATER AGWO      0.326    RCHRES 34    EXTNL IVOL
IMPLND 14 IWATER SURO     14.274    RCHRES 34    EXTNL IVOL

```

```

*** DM2
PERLND 16 PWATER SURO      *****  RCHRES 37    EXTNL IVOL
PERLND 16 PWATER IFWO      *****  RCHRES 37    EXTNL IVOL
PERLND 26 PWATER SURO      1.232    RCHRES 37    EXTNL IVOL
PERLND 26 PWATER IFWO      1.232    RCHRES 37    EXTNL IVOL
IMPLND 14 IWATER SURO      0.821    RCHRES 37    EXTNL IVOL

```

```

*** DM3
PERLND 26 PWATER SURO      3.645    RCHRES 5     EXTNL IVOL
PERLND 26 PWATER IFWO      3.645    RCHRES 5     EXTNL IVOL
PERLND 26 PWATER AGWO      3.628    RCHRES 5     EXTNL IVOL
PERLND 54 PWATER SURO      0.013    RCHRES 5     EXTNL IVOL
PERLND 54 PWATER IFWO      0.013    RCHRES 5     EXTNL IVOL
PERLND 54 PWATER AGWO      0.013    RCHRES 5     EXTNL IVOL
IMPLND 14 IWATER SURO      5.030    RCHRES 5     EXTNL IVOL

```

```

***Add non-contiguous GW basin***
PERLND 26 PWATER AGWO      0.016    RCHRES 5     EXTNL IVOL

```

```

*** DM4
PERLND 16 PWATER PERO      0.291    RCHRES 5     EXTNL IVOL
      RLND 26 PWATER PERO      0.589    RCHRES 5     EXTNL IVOL
PERLND 54 PWATER PERO      0.005    RCHRES 5     EXTNL IVOL
IMPLND 14 IWATER SURO      3.340    RCHRES 5     EXTNL IVOL

```

```

***Add non-contiguous GW basin***
PERLND 26 PWATER AGWO      0.001    RCHRES 5     EXTNL IVOL

```

```

*** DMS
PERLND 16 PWATER PERO      0.173    RCHRES 5     EXTNL IVOL
PERLND 26 PWATER PERO      0.493    RCHRES 5     EXTNL IVOL
PERLND 34 PWATER PERO      0.074    RCHRES 5     EXTNL IVOL
PERLND 44 PWATER PERO      0.080    RCHRES 5     EXTNL IVOL
PERLND 54 PWATER PERO      0.112    RCHRES 5     EXTNL IVOL
IMPLND 14 IWATER SURO      0.812    RCHRES 5     EXTNL IVOL

```

```

*** DM6
PERLND 16 PWATER PERO      0.000    RCHRES 40    EXTNL IVOL
PERLND 26 PWATER PERO      0.534    RCHRES 40    EXTNL IVOL
PERLND 34 PWATER PERO      0.002    RCHRES 40    EXTNL IVOL
PERLND 44 PWATER PERO      0.709    RCHRES 40    EXTNL IVOL
PERLND 54 PWATER PERO      0.312    RCHRES 40    EXTNL IVOL
IMPLND 14 IWATER SURO      0.008    RCHRES 40    EXTNL IVOL

```

```

*** WEST BRANCH OF CREEK

```

```

*** DM7
PERLND 16 PWATER SURO      2.190    RCHRES 7     EXTNL IVOL
PERLND 16 PWATER IFWO      2.190    RCHRES 7     EXTNL IVOL
PERLND 16 PWATER AGWO      1.701    RCHRES 7     EXTNL IVOL
PERLND 26 PWATER SURO      2.944    RCHRES 7     EXTNL IVOL
PERLND 26 PWATER IFWO      2.944    RCHRES 7     EXTNL IVOL
PERLND 26 PWATER AGWO      0.759    RCHRES 7     EXTNL IVOL
PERLND 34 PWATER SURO      1.969    RCHRES 7     EXTNL IVOL
PERLND 34 PWATER IFWO      1.969    RCHRES 7     EXTNL IVOL
PERLND 34 PWATER AGWO      0.681    RCHRES 7     EXTNL IVOL
      RLND 44 PWATER SURO      4.142    RCHRES 7     EXTNL IVOL
      RLND 44 PWATER IFWO      4.142    RCHRES 7     EXTNL IVOL
PERLND 44 PWATER AGWO      0.313    RCHRES 7     EXTNL IVOL

```

PERLND	54	PWATER	SURO	0.551	RCHRES	7	EXTNL	IVOL
PERLND	54	PWATER	IFWO	0.551	RCHRES	7	EXTNL	IVOL
PERLND	54	PWATER	AGWO	0.370	RCHRES	7	EXTNL	IVOL
IMPLND	14	IWATER	SURO	2.399	RCHRES	7	EXTNL	IVOL

*** DM8

PERLND	16	PWATER	SURO	0.203	RCHRES	7	EXTNL	IVOL
PERLND	16	PWATER	IFWO	0.203	RCHRES	7	EXTNL	IVOL
PERLND	16	PWATER	AGWO	*****	RCHRES	7	EXTNL	IVOL
PERLND	26	PWATER	SURO	0.609	RCHRES	7	EXTNL	IVOL
PERLND	26	PWATER	IFWO	0.609	RCHRES	7	EXTNL	IVOL
PERLND	26	PWATER	AGWO	0.098	RCHRES	7	EXTNL	IVOL
PERLND	34	PWATER	SURO	0.715	RCHRES	7	EXTNL	IVOL
PERLND	34	PWATER	IFWO	0.715	RCHRES	7	EXTNL	IVOL
PERLND	34	PWATER	AGWO	0.226	RCHRES	7	EXTNL	IVOL
PERLND	44	PWATER	SURO	1.132	RCHRES	7	EXTNL	IVOL
PERLND	44	PWATER	IFWO	1.132	RCHRES	7	EXTNL	IVOL
PERLND	44	PWATER	AGWO	0.154	RCHRES	7	EXTNL	IVOL
PERLND	54	PWATER	SURO	0.161	RCHRES	7	EXTNL	IVOL
PERLND	54	PWATER	IFWO	0.161	RCHRES	7	EXTNL	IVOL
PERLND	54	PWATER	AGWO	0.116	RCHRES	7	EXTNL	IVOL
IMPLND	14	IWATER	SURO	2.420	RCHRES	7	EXTNL	IVOL

*** DM9

PERLND	16	PWATER	SURO	0.002	RCHRES	9	EXTNL	IVOL
PERLND	16	PWATER	IFWO	0.002	RCHRES	9	EXTNL	IVOL
PERLND	16	PWATER	AGWO	0.002	RCHRES	9	EXTNL	IVOL
PERLND	26	PWATER	SURO	1.200	RCHRES	9	EXTNL	IVOL
PERLND	26	PWATER	IFWO	1.200	RCHRES	9	EXTNL	IVOL
PERLND	26	PWATER	AGWO	0.435	RCHRES	9	EXTNL	IVOL
PERLND	34	PWATER	SURO	0.016	RCHRES	9	EXTNL	IVOL
PERLND	34	PWATER	IFWO	0.016	RCHRES	9	EXTNL	IVOL
PERLND	34	PWATER	AGWO	0.016	RCHRES	9	EXTNL	IVOL
PERLND	44	PWATER	SURO	3.040	RCHRES	9	EXTNL	IVOL
PERLND	44	PWATER	IFWO	3.040	RCHRES	9	EXTNL	IVOL
PERLND	44	PWATER	AGWO	1.512	RCHRES	9	EXTNL	IVOL
PERLND	54	PWATER	SURO	0.010	RCHRES	9	EXTNL	IVOL
PERLND	54	PWATER	IFWO	0.010	RCHRES	9	EXTNL	IVOL
PERLND	54	PWATER	AGWO	0.010	RCHRES	9	EXTNL	IVOL
IMPLND	14	IWATER	SURO	0.634	RCHRES	9	EXTNL	IVOL

*** DM10

PERLND	16	PWATER	PERO	0.945	RCHRES	43	EXTNL	IVOL
PERLND	26	PWATER	PERO	0.738	RCHRES	43	EXTNL	IVOL
PERLND	34	PWATER	PERO	1.935	RCHRES	43	EXTNL	IVOL
PERLND	44	PWATER	PERO	0.510	RCHRES	43	EXTNL	IVOL
PERLND	54	PWATER	PERO	0.712	RCHRES	43	EXTNL	IVOL
IMPLND	14	IWATER	SURO	0.185	RCHRES	43	EXTNL	IVOL

*** DM11

PERLND	16	PWATER	PERO	0.321	RCHRES	43	EXTNL	IVOL
PERLND	26	PWATER	PERO	0.408	RCHRES	43	EXTNL	IVOL
PERLND	34	PWATER	PERO	1.024	RCHRES	43	EXTNL	IVOL
PERLND	44	PWATER	PERO	0.467	RCHRES	43	EXTNL	IVOL
PERLND	54	PWATER	PERO	1.036	RCHRES	43	EXTNL	IVOL
IMPLND	14	IWATER	SURO	2.726	RCHRES	43	EXTNL	IVOL

*** DM12

PERLND	16	PWATER	PERO	0.510	RCHRES	12	EXTNL	IVOL
PERLND	26	PWATER	PERO	0.001	RCHRES	12	EXTNL	IVOL
PERLND	34	PWATER	PERO	0.375	RCHRES	12	EXTNL	IVOL
PERLND	44	PWATER	PERO	1.740	RCHRES	12	EXTNL	IVOL
PERLND	54	PWATER	PERO	0.543	RCHRES	12	EXTNL	IVOL

*** DM13

PERLND	16	PWATER	PERO	0.961	RCHRES	13	EXTNL	IVOL
PERLND	26	PWATER	PERO	1.562	RCHRES	13	EXTNL	IVOL
PERLND	34	PWATER	PERO	1.203	RCHRES	13	EXTNL	IVOL
PERLND	44	PWATER	PERO	1.842	RCHRES	13	EXTNL	IVOL
PERLND	54	PWATER	PERO	0.025	RCHRES	13	EXTNL	IVOL
IMPLND	14	IWATER	SURO	1.259	RCHRES	13	EXTNL	IVOL

** LOWER BASIN

```

*** DM14
PERLND 16 PWATER PERO      0.481   RCHRES 14   EXTNL IVOL
PERLND 26 PWATER PERO      0.295   RCHRES 14   EXTNL IVOL
PERLND 34 PWATER PERO      1.940   RCHRES 14   EXTNL IVOL
PERLND 44 PWATER PERO      1.195   RCHRES 14   EXTNL IVOL
IMPLND 14 IWATER SURO      0.340   RCHRES 14   EXTNL IVOL

```

*** EXECUTEL TRIBUTARY

```

*** DM16 INFLOW TO EXECUTEL POND REACH
PERLND 16 PWATER SURO      0.647   RCHRES 46   EXTNL IVOL
PERLND 16 PWATER IFWO      0.647   RCHRES 46   EXTNL IVOL
PERLND 16 PWATER AGWO      0.446   RCHRES 46   EXTNL IVOL
PERLND 26 PWATER SURO      5.573   RCHRES 46   EXTNL IVOL
PERLND 26 PWATER IFWO      5.573   RCHRES 46   EXTNL IVOL
PERLND 26 PWATER AGWO      3.845   RCHRES 46   EXTNL IVOL
PERLND 34 PWATER SURO      0.639   RCHRES 46   EXTNL IVOL
PERLND 34 PWATER IFWO      0.639   RCHRES 46   EXTNL IVOL
PERLND 34 PWATER AGWO      0.441   RCHRES 46   EXTNL IVOL
PERLND 44 PWATER SURO      8.023   RCHRES 46   EXTNL IVOL
PERLND 44 PWATER IFWO      8.023   RCHRES 46   EXTNL IVOL
PERLND 44 PWATER AGWO      5.536   RCHRES 46   EXTNL IVOL
PERLND 54 PWATER SURO      0.183   RCHRES 46   EXTNL IVOL
PERLND 54 PWATER IFWO      0.183   RCHRES 46   EXTNL IVOL
PERLND 54 PWATER AGWO      0.126   RCHRES 46   EXTNL IVOL
IMPLND 14 IWATER SURO      4.249   RCHRES 46   EXTNL IVOL

```

```

*** DM17
PERLND 16 PWATER PERO      2.078   RCHRES 17   EXTNL IVOL
PERLND 26 PWATER PERO      2.261   RCHRES 17   EXTNL IVOL
PERLND 34 PWATER PERO      3.003   RCHRES 17   EXTNL IVOL
PERLND 44 PWATER PERO      3.280   RCHRES 17   EXTNL IVOL
IMPLND 14 IWATER SURO      2.655   RCHRES 17   EXTNL IVOL

```

*** MAINSTEM RAVINE

```

*** DM18
PERLND 16 PWATER PERO      0.789   RCHRES 18   EXTNL IVOL
PERLND 26 PWATER PERO      0.277   RCHRES 18   EXTNL IVOL
PERLND 34 PWATER PERO      3.151   RCHRES 18   EXTNL IVOL
PERLND 44 PWATER PERO      1.106   RCHRES 18   EXTNL IVOL
PERLND 54 PWATER PERO      0.300   RCHRES 18   EXTNL IVOL
IMPLND 14 IWATER SURO      0.296   RCHRES 18   EXTNL IVOL

```

*** NORTH BRANCH RAVINE

```

*** DM19
PERLND 16 PWATER PERO      0.182   RCHRES 177  EXTNL IVOL
PERLND 26 PWATER PERO      6.019   RCHRES 177  EXTNL IVOL
PERLND 34 PWATER PERO      0.167   RCHRES 177  EXTNL IVOL
PERLND 44 PWATER PERO      5.552   RCHRES 177  EXTNL IVOL
IMPLND 14 IWATER SURO      2.617   RCHRES 177  EXTNL IVOL

```

```

*** DM20
PERLND 16 PWATER PERO      4.007   RCHRES 193  EXTNL IVOL
PERLND 26 PWATER PERO      6.624   RCHRES 193  EXTNL IVOL
PERLND 34 PWATER PERO      2.784   RCHRES 193  EXTNL IVOL
PERLND 44 PWATER PERO      4.602   RCHRES 193  EXTNL IVOL
PERLND 54 PWATER PERO      0.116   RCHRES 193  EXTNL IVOL
IMPLND 14 IWATER SURO      3.714   RCHRES 193  EXTNL IVOL

```

*** LOWER MAINSTEM

```

*** DM21
PERLND 16 PWATER PERO      2.143   RCHRES 198  EXTNL IVOL
PERLND 26 PWATER PERO      6.306   RCHRES 198  EXTNL IVOL
PERLND 34 PWATER PERO      1.429   RCHRES 198  EXTNL IVOL
PERLND 44 PWATER PERO      4.205   RCHRES 198  EXTNL IVOL
IMPLND 14 IWATER SURO      3.091   RCHRES 198  EXTNL IVOL

```

```

*** DM22
PERLND 16 PWATER PERO      0.381   RCHRES 198  EXTNL IVOL

```

PERLND	26	PWATER	PERO	4.654	RCHRES	198	EXTNL	IVOL
PERLND	34	PWATER	PERO	0.218	RCHRES	198	EXTNL	IVOL
PERLND	44	PWATER	PERO	2.620	RCHRES	198	EXTNL	IVOL
PERLND	54	PWATER	PERO	0.016	RCHRES	198	EXTNL	IVOL
IMPLND	14	IWATER	SURO	1.972	RCHRES	198	EXTNL	IVOL

*** NONCONTIGUOUS GROUNDWATER BASINS

*** G1

PERLND	16	PWATER	AGWO	2.833	RCHRES	5	EXTNL	IVOL
PERLND	26	PWATER	AGWO	9.917	RCHRES	5	EXTNL	IVOL

*** G2

PERLND	16	PWATER	AGWO	0.417	RCHRES	193	EXTNL	IVOL
PERLND	26	PWATER	AGWO	1.333	RCHRES	193	EXTNL	IVOL

*** G3

PERLND	16	PWATER	AGWO	5.083	RCHRES	193	EXTNL	IVOL
PERLND	26	PWATER	AGWO	17.667	RCHRES	193	EXTNL	IVOL
PERLND	34	PWATER	AGWO	1.167	RCHRES	193	EXTNL	IVOL
PERLND	44	PWATER	AGWO	4.250	RCHRES	193	EXTNL	IVOL

*** CHANNEL NETWORK LINKAGES ***

*** DISCHARGE FROM IWS SUBBASINS

RCHRES	360	HYDR	ROVOL	1	RCHRES	36	EXTNL	IVOL
RCHRES	366	HYDR	ROVOL	1	RCHRES	5	EXTNL	IVOL

*** EAST BRANCH OF CREEK

RCHRES	34	HYDR	ROVOL	1	RCHRES	35	EXTNL	IVOL
RCHRES	35	HYDR	ROVOL	1	RCHRES	37	EXTNL	IVOL
RCHRES	36	HYDR	ROVOL	1	COPY	16	INPUT	MEAN 1
COPY	14	OUTPUT	MEAN	1	COPY	16	INPUT	MEAN 1
COPY	15	OUTPUT	MEAN	1	COPY	16	INPUT	MEAN 1
RCHRES	39	HYDR	ROVOL	1	COPY	16	INPUT	MEAN 1
RCHRES	37	HYDR	ROVOL	1	COPY	16	INPUT	MEAN 1
COPY	16	OUTPUT	MEAN	1	RCHRES	38	EXTNL	IVOL
RCHRES	38	HYDR	ROVOL	1	RCHRES	5	EXTNL	IVOL
RCHRES	5	HYDR	ROVOL	1	RCHRES	40	EXTNL	IVOL
RCHRES	40	HYDR	ROVOL	1	COPY	5	INPUT	MEAN 1

*** WEST BRANCH OF CREEK

COPY	20	OUTPUT	MEAN	1	COPY	9	INPUT	MEAN 1
COPY	42	OUTPUT	MEAN	1	COPY	9	INPUT	MEAN 1
COPY	9	OUTPUT	MEAN	1	RCHRES	4	EXTNL	IVOL
RCHRES	4	HYDR	ROVOL	1	COPY	41	INPUT	MEAN 1
COPY	50	OUTPUT	MEAN	1	COPY	4	INPUT	MEAN 1
COPY	3	OUTPUT	MEAN	1	COPY	4	INPUT	MEAN 1
RCHRES	7	HYDR	ROVOL	1	COPY	4	INPUT	MEAN 1
RCHRES	9	HYDR	ROVOL	1	COPY	4	INPUT	MEAN 1
COPY	4	OUTPUT	MEAN	1	RCHRES	43	EXTNL	IVOL
COPY	41	OUTPUT	MEAN	1	RCHRES	43	EXTNL	IVOL
RCHRES	43	HYDR	ROVOL	1	RCHRES	12	EXTNL	IVOL
COPY	10	OUTPUT	MEAN	1	COPY	5	INPUT	MEAN 1
RCHRES	12	HYDR	ROVOL	1	COPY	5	INPUT	MEAN 1

*** MAINSTEM BELOW CONFLUENCE OF E. AND W. BRANCH

*** MAINSTEM ABOVE EXECUTEL TRIBUTARY

COPY	5	OUTPUT	MEAN	1	RCHRES	13	EXTNL	IVOL
RCHRES	13	HYDR	ROVOL	1	RCHRES	14	EXTNL	IVOL
RCHRES	14	HYDR	ROVOL	1	COPY	48	INPUT	MEAN 1

*** EXECUTEL TRIBUTARY

RCHRES	46	HYDR	ROVOL	1	RCHRES	47	EXTNL	IVOL
--------	----	------	-------	---	--------	----	-------	------

```

RCHRES 47 HYDR ROVOL 1          RCHRES 17  EXTNL IVOL
RCHRES 17 HYDR ROVOL 1          COPY 48  INPUT MEAN 1
*****
** MAINSTEM FROM HEAD OF RAVINE TO NORTH BRANCH CONFLUENCE
COPY 48 OUTPUT MEAN 1          RCHRES 18  EXTNL IVOL
RCHRES 18 HYDR ROVOL 1          RCHRES 193 EXTNL IVOL
RCHRES 193 HYDR ROVOL 1          COPY 1  INPUT MEAN 1
*****
*** NORTH BRANCH RAVINE TO MAINSTEM
RCHRES 177 HYDR ROVOL 1          COPY 1  INPUT MEAN 1
*****
*** MAINSTEM FROM NORTH BRANCH CONFLUENCE TO PARK BELOW MVD CULVERT
COPY 1 OUTPUT MEAN 1          RCHRES 198 EXTNL IVOL
*****

```

END NETWORK

END RUN

2006 CONDITIONS

AR 020382

**HSPF Model Schematic
Des Moines Creek
Low Flow Analysis
2006 Conditions**

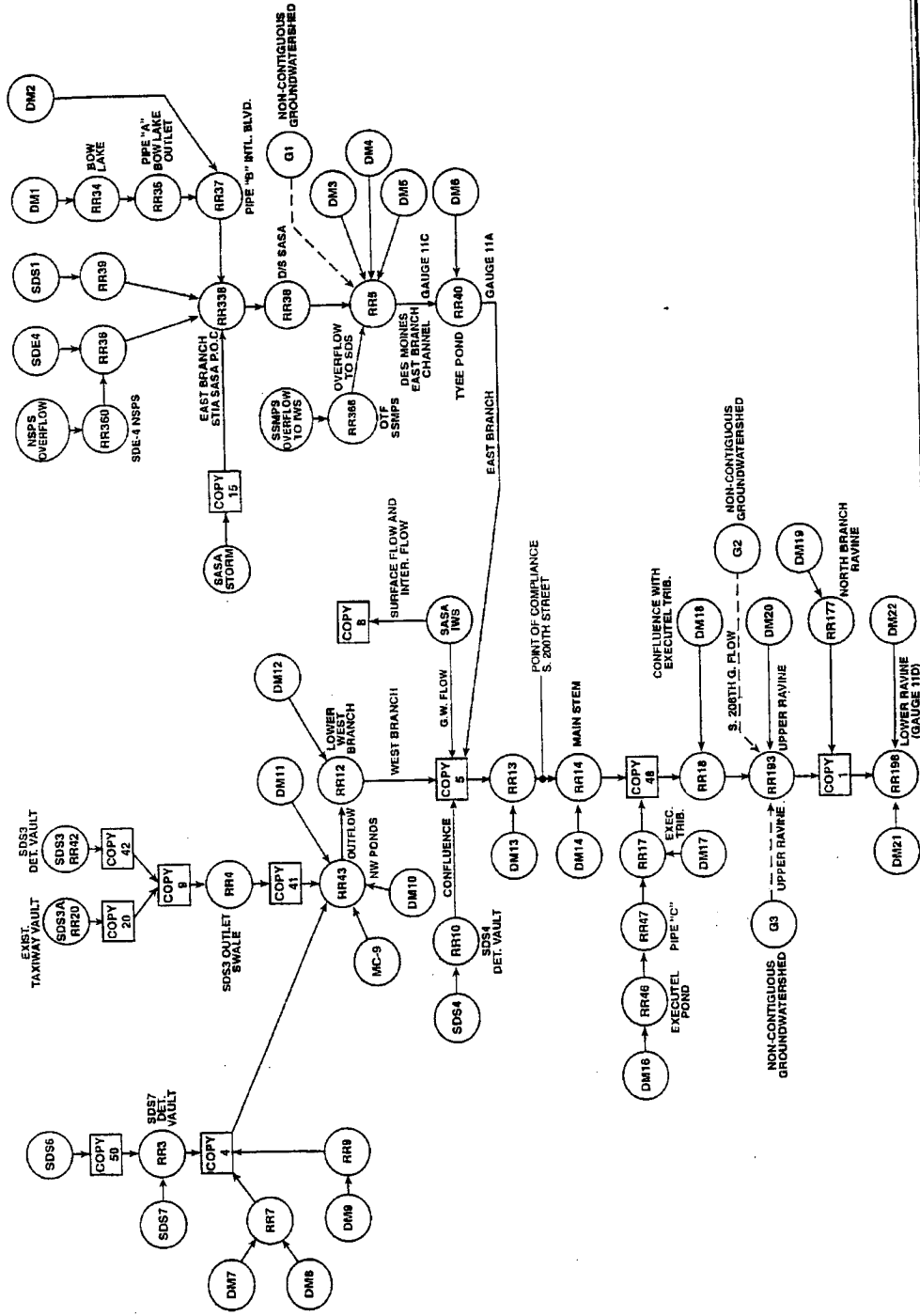

Parameter/Dx, Inc. Part of Environmental Systems 2812 (04/10/2006) 12/01 P1

DM = Des Moines Creek Subbasin Number

SDE# = Storm Drainage South Number

SDE# = Storm Drainage East Number

RR = Routing Reach Number (Channel or Storage Pond)

DM1
RR12

Subbasin ID
Routing Reach Number

COPY 8

Summation of
upstream flow

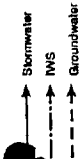

RUN

GLOBAL

```
*** FILE: DMO6RLF4.INP (MODIFY DMO6RGM.INP)
*** HSPF MODEL OF DES MOINES CREEK, Low Flow Analysis, 2006 conditions
*** This is the low flow frequency analysis file only
*** GW contributions are based on the 2006 basins and 2006 conditions.
*** GW contributions were added/ revised in most basins by revising AGWO
*** GW contributions were also added for SASA-SDS and MC-9 (These basins were added to the model)
*** Surface water contributions were revised based on the 2006 basins land use.
*** PERO of basins DM-3, Dm-4, Dm-5, Dm-10, Dm-11, Dm-12, DM-13 were replaced.
*** with SDR0, IFWO and AGWO flows.
*** GW contributions from non-contiguous D3 and D4 were added to the model.
DES MOINES CREEK BASIN HSPF MODEL
START 1948/10/01 00:00 END 1996/09/30 24:00
START 1992/01/01 00:00 END 1996/09/30 24:00***
RUN INTERP OUTPUT LEVEL 10
RESUME 0 RUN 1
END GLOBAL
```

```
FILES
MESSU 24 DMO6.MES
WDM 25 DMO6RLF1.WDM
END FILES
```

```
OPN SEQUENCE
INGRP INDELT 01:00
PERLND 16
PERLND 26
PERLND 34
PERLND 44
PERLND 45
PERLND 54
IMPLND 14
RCHRES 360
RCHRES 36
RCHRES 39
RCHRES 20
RCHRES 42
COPY 9
RCHRES 4
COPY 41
RCHRES 10
RCHRES 366
COPY 8
COPY 50
RCHRES 3
RCHRES 7
RCHRES 9
COPY 4
RCHRES 43
COPY 15
RCHRES 34
RCHRES 35
RCHRES 37
RCHRES 338
RCHRES 38
RCHRES 5
RCHRES 40
RCHRES 12
COPY 5
RCHRES 13
RCHRES 14
RCHRES 177
RCHRES 46
RCHRES 47
RCHRES 17
COPY 48
RCHRES 18
RCHRES 193
COPY 1
RCHRES 198
END INGRP
END OPN SEQUENCE
```

```
PERLND
GEN-INFO
```

AR 020384

```

<PLS >          Name          NBLKS  Unit-systems  Printer
# - #           User t-series Engr Metr
#           in  out
16  TEM- TILL FOR MOD          1   1   1   1   60   0
26  TGM- TILL GR MOD          1   1   1   1   60   0
34  OF - OUTWASH FOR          1   1   1   1   60   0
44  OG - OUTWASH GR           1   1   1   1   60   0
45  AF - AIRPORT FILL         1   1   1   1   60   0
54  SA - WETLANDS             1   1   1   1   60   0

```

END GEN-INFO

```

ACTIVITY
<PLS > ***** Active Sections *****
# - # ATMP SNOW PWAT SED PST FWG PQAL MSTL PEST NITR PHOS TRAC
14  54  0  0  0  1  0  0  0  0  0  0  0  0  0  0  0

```

END ACTIVITY

```

PRINT-INFO
<PLS > ***** Print-flags ***** PIVL PYR
# - # ATMP SNOW PWAT SED PST FWG PQAL MSTL PEST NITR PHOS TRAC
14  54  0  0  0  6  0  0  0  0  0  0  0  0  0  1  9

```

END PRINT-INFO

```

PWAT-PARM1
<PLS > ***** Flags *****
# - # CSNO RTOP UZFG VCS VUZ VNN VIFW VIRC VLE
14  54  0  0  0  0  0  0  0  0  0  0

```

END PWAT-PARM1

```

PWAT-PARM2
<PLS > ***
# - # ***FOREST  LZSN  INFILT  LSUR  SLSUR  KVARY  AGWRC
16  4.5000  0.2000  200.00  0.1000  0.5000  0.9960
26  4.5000  0.0750  400.00  0.1000  0.5000  0.9960
34  5.0000  2.0000  200.00  0.0500  0.3000  0.9960
44  5.0000  0.8000  200.00  0.0500  0.3000  0.9960
45  7.5000  0.0200  300.00  0.0700  0.0000  0.9960
54  4.0000  2.0000  200.00  0.0010  0.5000  0.9960

```

END PWAT-PARM2

```

PWAT-PARM3
<PLS > ***
# - # *** PETMAX  PETMIN  INFEXP  INFILD  DEEPFR  BASETP  AGWETP
16  2.0000  2.0000  2.0000  0.55  0.00  0.00  0.0
26  2.0000  2.0000  2.0000  0.55  0.00  0.00  0.0
34  2.0000  2.0000  2.0000  0.55  0.00  0.00  0.0
44  2.0000  2.0000  2.0000  0.55  0.00  0.00  0.0
45  2.0000  2.0000  2.0000  0.55  0.00  0.00  0.0
54  10.000  2.0000  2.0000  0.55  0.00  0.00  0.7

```

END PWAT-PARM3

```

PWAT-PARM4
<PLS > *****
# - # CEPSC  UZSN  NSUR  INTFW  IRC  LZETP***
16  0.2000  0.5000  0.3500  3.000  0.5000  0.7000
26  0.1000  0.2500  0.2500  3.000  0.5000  0.2500
34  0.2000  0.5000  0.3500  0.000  0.7000  0.7000
44  0.1000  0.5000  0.2500  0.000  0.7000  0.2500
45  0.1000  0.2800  0.2500  6.000  0.1500  0.6000
54  0.2000  3.0000  0.5000  1.000  0.7000  0.8000

```

END PWAT-PARM4

```

PWAT-STATE1
<PLS > PWATER state variables***
# - # *** CEPS  SURS  UZS  IFWS  LZS  AGWS  GWVS
16  0.078  0.  0.0010  0.  0.075  0.267  0.026
26  0.051  0.  0.0350  0.  1.928  0.680  0.049
34  0.078  0.  0.0010  0.  0.090  0.676  0.038
44  0.051  0.  0.0040  0.  1.127  0.614  0.152
45  0.051  0.  0.0200  0.  1.528  0.647  0.101
54  0.051  0.  0.3330  0.  0.622  0.000  0.000

```

END PWAT-STATE1

END PERLND

IMPLND

```

GEN-INFO
<ILS >          Name          Unit-systems  Printer
# - #           User t-series Engr Metr
#           in  out
13  140 IMPERVIOUS          1   1   1   60   0

```

END GEN-INFO

ACTIVITY

```

<ILS > ***** Active Sections *****
# - # ATMP SNOW IWAT SLD IWG IQAL ***
13 140 0 0 1 0 0 0
END ACTIVITY
PRINT-INFO
<ILS > ***** Print-flags ***** PIVL PYR
# - # ATMP SNOW IWAT SLD IWG IQAL *****
13 140 0 0 6 0 0 0 1 9
END PRINT-INFO
IWAT-PARM1
<ILS >
# - # CSNO RTOP VRS VNN RTLI ***
13 140 0 0 0 0 0 0
END IWAT-PARM1
IWAT-PARM2
<ILS >
# - # LSUR SLSUR NSUR RETSC ***
14 500.0 0.0100 0.1000 0.100
140 100.00 0.0500 0.1000 0.0500
END IWAT-PARM2
IWAT-PARM3
<ILS >
# - # PETMAX PETMIN
13 140
END IWAT-PARM3
IWAT-STATE1
<ILS > IWATER state variables
# - # RETS SURS
13 140 1.0000E-3 1.0000E-3
END IWAT-STATE1
END IMPLND

```

```

RCHRES
GEN-INFO
RCHRES
# - # Name Nexits Unit Systems Printer
# - # <-----><-----> User T-series Engrl Metz LKFG
# - # in out

```

#	Name	Nexits	Unit	Systems	Printer	Engrl	Metz	LKFG
3	SDS-7 Det. Vault	1	1	1	1	0	0	0
4	SDS-3 Outlet Swale	1	1	1	1	0	0	0
5	E.Branch above TyeeP	1	1	1	1	0	0	0
7	DM7 & DM8 Conveyance	1	1	1	1	0	0	0
9	DM9 Conveyance	1	1	1	1	0	0	0
10	SDS-4 Det. Vault	1	1	1	1	0	0	0
12	Lower W. Branch	1	1	1	1	0	0	0
13	Confl. to 200th St.	1	1	1	1	0	0	0
14	200th to Exec. Trib.	1	1	1	1	0	0	0
17	Executel Tributary	1	1	1	1	0	0	0
18	Exec.Confl. to 208th	2	1	1	1	0	0	0
20	SDS-3A Det. Vault	1	1	1	1	0	0	0
34	Bow Lake	2	1	1	1	0	0	1
35	Pipe A Bow LK Outlet	1	1	1	1	0	0	0
36	SDE-4 Combined Disch	1	1	1	1	0	0	0
37	Pipe B 60" Intl Blvd	1	1	1	1	0	0	0
38	D/S SASA	1	1	1	1	0	0	0
39	SDS-1 Storm Only	1	1	1	1	0	0	0
40	Tyee Pond	1	1	1	1	0	0	0
42	SDS-3 Det. Vault	1	1	1	1	0	0	0
43	NW Ponds	2	1	1	1	0	0	1
46	Executel Pond	1	1	1	1	0	0	0
47	Pipe C Exec.Pond Dis	1	1	1	1	0	0	0
177	North Branch Ravine	1	1	1	1	0	0	0
193	Upper Ravine	1	1	1	1	0	0	0
198	Lower Ravine	1	1	1	1	0	0	0
338	E.BR. STIA SASA POC	1	1	1	1	0	0	0
360	SDE-4 NSPS	2	1	1	1	0	0	0
366	OTF SSMPS	2	1	1	1	0	0	0

```

END GEN-INFO

```

```

ACTIVITY
RCHRES ***** Active Sections *****
# - # HYFG ADFG CNFG HTFG SDFG GQFG OXFG NUFG PKFG PHFG
1 366 1 0 0 0 0 0 0 0 0 0 0
END ACTIVITY
PRINT-INFO
RCHRES ***** Printout Flags ***** PIVL PYR
# - # HYDR ADCA CONS HEAT SED GQL OXRX NUTR PLNK PHCB *****

```

1 366 6 0 0 0 0 0 0 0 0 0 0 1 9

END PRINT-INFO

HYDR-PARM1

# - #	Flags for each HYDR Section				ODGTFG for each possible exit				ODGTFG for each possible exit				FUNCT for each possible exit			
	VC	A1	A2	A3	FG	FG	FG	FG	FG	FG	FG	FG	FG	FG	FG	FG
3	17	0	1	1	0	4	0	0	0	0	0	0	0	0	0	0
18		0	1	1	0	4	5	0	0	0	0	0	0	0	0	0
20		0	1	1	0	4	0	0	0	0	0	0	0	0	0	0
34		0	1	1	0	4	5	0	0	0	0	0	0	0	0	0
35	40	0	1	1	0	4	0	0	0	0	0	0	0	0	0	0
42		0	1	1	0	4	0	0	0	0	0	0	0	0	0	0
43		0	1	1	0	4	5	0	0	0	0	0	0	0	0	0
46	338	0	1	1	0	4	0	0	0	0	0	0	0	0	0	0
360	366	0	1	1	0	4	5	0	0	0	0	0	0	0	0	0

END HYDR-PARM1

HYDR-PARM2

# - #	FTABNO	LEN	DELTH	STCOR	KS	DB50
3	3	0.071			0.3	
4	4	0.530			0.3	
5	5	0.380			0.3	
7	7	0.341			0.3	
9	9	0.189			0.3	
10	10	0.071			0.3	
12	12	0.273			0.3	
13	13	0.218			0.3	
14	14	0.218			0.3	
17	17	0.246			0.3	
18	18	0.303			0.3	
20	20	0.071			0.3	
34	34	0.208			0.3	
35	35	0.123			0.3	
36	36	0.100			0.3	
37	37	0.381			0.3	
38	38	0.142			0.3	
39	39	0.100			0.3	
40	40	0.189			0.3	
42	42	0.071			0.3	
43	43	0.189			0.3	
46	46	0.047			0.3	
47	47	0.417			0.3	
177	177	0.407			0.3	
193	193	0.795			0.3	
198	198	0.631			0.3	
338	338	0.010			0.3	
360	360	0.010			0.0	
366	366	0.010			0.0	

END HYDR-PARM2

HYDR-INIT

# - #	Initial value of COLIND for each possible exit	Initial value of OUTDGT for each possible exit
3	0.1	4.0
4	0.1	4.0
5	0.1	4.0
7	0.1	4.0
9	0.1	4.0
10	0.1	4.0
12	0.1	4.0
13	0.1	4.0
14	0.1	4.0
17	0.1	4.0
18	0.1	4.0 5.0
20	0.1	4.0
34	35.	4.0 5.0
35	0.0	4.0
36	0.0	4.0
37	0.0	4.0
38	0.0	4.0
39	0.0	4.0

40	0.0	4.0
42	0.1	4.0
43	0.7	4.0 5.0
46	0.0	4.0
47	0.0	4.0
177	0.0	4.0
193	0.0	4.0
198	0.0	4.0
338	0.0	4.0
360	0.0	4.0 5.0
366	0.0	4.0 5.0

END HYDR-INIT
END RCHRES

FTABLE 3

*** SDS-7 DETENTION VAULT 20 FT DEPTH 36-in riser diam.+3 orifices
*** SDS-7 DET. VAULT accepts runoff from SDS-6 and SDS-7
ROWS COLS ***

DEPTH (FT)	AREA (ACRES)	VOLUME (ACRE-FT)	OUTFLOW (CFS)
0.00	1.079	0.00	0.00
1.72	1.079	1.86	0.53
7.30	1.079	7.87	1.10
14.28	1.079	15.40	1.54
14.50	1.079	15.64	1.55
14.59	1.079	15.74	1.58
15.34	1.079	16.55	2.10
17.20	1.079	18.55	2.59
17.50	1.079	18.88	2.66
17.55	1.079	18.93	2.67
17.69	1.079	19.08	2.79
17.83	1.079	19.23	2.99
18.25	1.079	19.69	3.28
18.69	1.079	20.16	3.94
19.13	1.079	20.64	4.73
19.56	1.079	21.10	5.53
20.00	1.079	21.57	6.61
20.10	1.079	21.68	7.57
20.20	1.079	21.79	9.29
20.30	1.079	21.90	11.51
21.00	1.079	22.65	36.14
21.30	1.079	22.98	45.82
21.90	1.079	23.62	54.10

END FTABLE 3

FTABLE 4
*** SDS-3 OUTLET SWALE
ROWS COLS ***

DEPTH (FT)	AREA (ACRES)	VOLUME (ACRE-FT)	OUTFLOW (CFS)	OUTFLOW2 (CFS)
.000	.000	0.0	0.0	
.500	.198	0.1	9.0	
1.000	.236	0.5	30.9	
2.000	.306	1.0	115.8	
3.000	.376	1.5	265.5	
4.000	.446	5.0	491.8	
5.000	.517	20.0	806.3	

END FTABLE 4

FTABLE 5
*** EAST BRANCH ABOVE TYEE POND
ROWS COLS ***

DEPTH (FT)	AREA (ACRES)	VOLUME (ACRE-FT)	OUTFLOW (CFS)	OUTFLOW2 (CFS)
0.000	.000	.000	.000	
0.550	.290	.100	4.900	
1.100	.543	.200	20.800	
1.650	.609	.300	46.500	
2.200	.671	.400	80.000	
2.750	.732	0.500	118.700	

3.300	.778	0.600	159.500
3.850	.819	0.700	198.400
4.400	.849	0.801	231.900
4.950	.866	1.000	252.900
5.500	.865	1.200	253.000
8.200	.973	1.500	400.000
10.200	1.043	2.000	520.000

END FTABLE 5

FTABLE 7
 *** DM7 & DM8 CONVEYANCE
 ROWS COLS ***

DEPTH (FT)	AREA (ACRES)	VOLUME (ACRE-FT)	OUTFLOW (CFS)	OUTFLOW2 (CFS)
.000	.000	.000	.000	
.500	.360	.120	6.200	
1.000	.416	.276	20.800	
2.000	.520	.694	75.400	
3.000	.626	1.252	168.700	
4.000	.732	1.950	306.900	
5.000	.836	2.790	496.100	
6.000	.942	3.768	742.300	

END FTABLE 7

FTABLE 9
 *** DM9 CONVEYANCE
 ROWS COLS ***

DEPTH (FT)	AREA (ACRES)	VOLUME (ACRE-FT)	OUTFLOW (CFS)	OUTFLOW2 (CFS)
.000	.00	0.0	.0	
.500	.20	0.7	9.7	
1.000	.23	3.1	32.6	
2.000	.29	14.9	118	
3.000	.35	38.4	265	
4.000	.41	77	482	
5.000	.47	135	778	
6.000	.52	214	1165	

END FTABLE 9

FTABLE 10
 *** SDS-4 DETENTION VAULT 15 FT DEPTH 10-IN RISER DIA
 ROWS COLS ***

DEPTH	AREA	VOLUME	OUTFLOW	***
0.00	0.87	0.00	0.00	
0.54	0.87	0.471	0.180	
1.72	0.87	1.501	0.320	
2.60	0.87	2.270	0.394	
3.49	0.87	3.047	0.456	
5.25	0.87	4.583	0.559	
7.60	0.87	6.634	0.673	
8.19	0.87	7.149	0.699	
8.78	0.87	7.664	0.723	
9.37	0.87	8.179	0.747	
9.96	0.87	8.694	0.770	
10.54	0.87	9.201	0.793	
12.21	0.87	10.659	1.220	
14.55	0.87	12.701	2.240	
15.00	0.87	13.094	2.390	
15.10	0.87	13.181	2.670	
15.50	0.87	13.530	4.390	
16.80	0.80	14.665	6.400	

END FTABLE 10

FTABLE 12
 *** LOWER WEST BRANCH
 *** REVISED BASED ON HEC-RAS MODEL
 ROWS COLS ***

DEPTH (FT)	AREA (ACRES)	VOLUME (ACRE-FT)	OUTFLOW (CFS)	OUTFLOW2 (CFS)
.000	.000	0.000	.000	
.500	.291	0.030	0.150	
1.000	.346	0.250	6.600	

2.000	.450	0.430	14.100
3.000	.554	0.650	25.000
4.000	.656	1.180	50.000
5.000	.753	2.170	75.000
6.000	.796	3.820	100.000
7.000	.837	8.820	150.000
8.000	.837	16.200	200.000
9.000	.837	27.920	250.000
10.000	.837	33.530	350.000
11.000	.837	35.380	450.000

END FTABLE 12

FTABLE 13
 *** CONFLUENCE TO 200TH STREET
 ROWS COLS ***

9	4				
DEPTH	AREA	VOLUME	OUTFLOW	OUTFLOW2	
(FT)	(ACRES)	(ACRE-FT)	(CFS)	(CFS)	
.000	.000	.000	.000		
.500	.153	.051	4.300		
1.000	.272	.132	14.400		
2.000	.317	.312	50.400		
3.000	.360	.544	109.600		
4.000	.404	.826	195.000		
5.000	.450	1.163	309.500		
6.000	.497	1.548	456.300		
7.000	.542	1.984	638.000		

END FTABLE 13

FTABLE 14
 *** 200TH STREET TO EXECUTEL TRIBUTARY
 *** REACH 190 FROM TR-20/KING COUNTY BASIN PLAN MODEL:
 ROWS COLS ***

5	4				
DEPTH	AREA	VOLUME	OUTFLOW	OUTFLOW2	
(FT)	(ACRES)	(ACRE-FT)	(CFS)	(CFS)	
0.000	0.000	0.000	0.000		
0.900	0.70	0.4000	30.00		
1.800	0.80	1.1000	115.60		
2.700	1.10	2.1000	259.80		
4.200	1.30	4.3000	707.10		

END FTABLE 14

FTABLE 17
 *** EXECUTEL TRIBUTARY
 ROWS COLS ***

10	4				
DEPTH	AREA	VOLUME	OUTFLOW	OUTFLOW2	
(FT)	(ACRES)	(ACRE-FT)	(CFS)	(CFS)	
.000	.000	.000	.000		
.300	.169	.034	2.900		
.600	.192	.076	9.800		
.900	.211	.128	20.400		
1.200	.238	.189	35.100		
1.500	.259	.259	54.100		
1.800	.282	.336	77.700		
2.100	.303	.423	106.200		
3.100	.376	.779	245.000		
3.600	.412	.988	335.000		

END FTABLE 17

FTABLE 18
 *** CONFLUENCE WITH EXECUTEL TRIBUTARY TO 208TH STREET
 *** REPRESENTS GW LOSS IN WETLAND BELOW 200TH
 ROWS COLS ***

14	5				
DEPTH	AREA	VOLUME	OUTFLOW	OUTFLOW2	
(FT)	(ACRES)	(ACRE-FT)	(CFS)	(CFS)	
.000	.000	.000	.000	0.00	
.500	.572	.191	7.300	0.00	
1.000	.799	.438	10.000	0.00	
2.000	.968	1.001	20.700	0.00	
3.000	1.155	1.727	100.000	0.00	
4.000	1.317	2.542	262.700	0.00	
5.000	1.478	3.475	400.300	0.00	
6.000	1.643	4.545	570.200	0.00	

7.000	1.791	5.688	774.400	0.00
8.000	1.932	6.822	1015.100	0.00
9.000	1.945	7.025	1294.500	0.00
10.000	1.956	7.244	1614.500	0.00
11.000	1.970	7.481	1977.000	0.00
12.000	1.983	7.734	2384.700	0.00

END FTABLE 18

FTABLE 20
 *** SDS-3A EXISTING TAXIWAY DETENTION VAULT EFFECTIVE DEPTH=7.94 FT 36-IN RISER

ROWS COLS ***

14 4

DEPTH (FT)	AREA (ACRES)	VOLUME (ACRE-FT)	OUTFLOW (CFS)	***
0.00	0.69	0.00	0.00	***
1.06	0.69	0.73	1.09	
2.00	0.69	1.38	1.50	
3.08	0.69	2.12	1.86	
4.00	0.69	2.77	2.12	
5.10	0.69	3.51	2.39	
5.70	0.69	3.93	2.53	
6.24	0.69	4.30	4.47	
7.05	0.69	4.86	9.28	
7.58	0.69	5.22	12.80	
7.94	0.69	5.47	15.07	
8.54	0.69	5.88	28.76	
9.04	0.69	6.23	48.98	
9.54	0.69	6.57	58.41	

END FTABLE 20

FTABLE 34
 *** BOW LAKE
 *** BASED ON ENTRANCE CONTROL FOR 36 INCH OUTLET PIPE

ROWS COLS ***

8 5

DEPTH (FT)	AREA (ACRES)	VOLUME (ACRE-FT)	OUTFLOW (CFS)	OUTFLOW2 (CFS)	***
0.000	14.000	0.000	0.000	0.00	
1.000	14.000	14.000	7.000	0.00	
1.500	14.000	21.000	13.000	0.00	
2.000	14.000	28.000	17.000	0.00	
3.000	14.000	42.000	35.000	0.00	
4.000	14.000	56.000	49.000	0.00	
5.000	14.000	70.000	60.000	0.00	
6.000	14.000	84.000	78.000	0.00	

END FTABLE 34

FTABLE 35
 *** 36" BOW LAKE DISCHARGE PIPELINE (A)

ROWS COLS ***

13 4

DEPTH (FT)	AREA (ACRES)	VOLUME (ACRE-FT)	OUTFLOW (CFS)	OUTFLOW2 (CFS)	***
.000	.000	.000	.000		
.300	.020	.0006	1.000		
.600	.026	.0026	4.200		
.900	.032	.0068	9.400		
1.200	.034	.0134	16.200		
1.500	.037	.0226	24.000		
1.800	.039	.0346	32.300		
2.100	.040	.0492	40.100		
2.400	.040	.0667	46.900		
2.700	.039	.0857	51.200		
3.000	.037	.1000	55.300		
*** SURCHARGING-					
3.300	.038	.2500	60.300		
4.000	.038	.4000	80.000		

END FTABLE 35

FTABLE 36
 *** SDE-4 COMBINED DISCHARGE

ROWS COLS ***

11 4

DEPTH (FT)	AREA (ACRES)	VOLUME (ACRE-FT)	OUTFLOW (CFS)	OUTFLOW2 (CFS)	***
.000	.000	.000	.000		

AR 020391

.400	.343	0.090	2.200
.800	.442	0.150	9.500
1.200	.523	0.200	21.100
1.600	.577	0.250	36.300
2.000	.618	0.300	54.000
2.400	.646	0.350	72.500
2.800	.659	0.400	90.200
3.200	.662	0.450	105.500
3.600	.649	0.550	115.000
4.000	.618	0.650	115.100

END FTABLE 36

FTABLE 37
 *** 60" INTERNATIONAL BLVD PIPELINE (B)
 ROWS COLS ***

13	4				
***	DEPTH	AREA	VOLUME	OUTFLOW	OUTFLOW2
	(FT)	(ACRES)	(ACRE-FT)	(CFS)	(CFS)
	.000	.000	.000	.000	
	.450	.134	.045	4.800	
	.900	.190	.100	20.300	
	1.350	.225	.150	45.400	
	1.800	.249	.200	78.000	
	2.250	.266	.250	115.900	
	2.700	.271	.300	155.800	
	3.150	.264	.350	193.800	
	3.600	.251	.400	226.500	
	4.050	.238	.450	247.000	
	4.500	.234	.500	247.100	
	6.500	.185	.600	340.000	
	8.500	.166	.700	415.000	

END FTABLE 37

FTABLE 238
 *** STIA FLOW COMBINED (NOT USED)
 ROWS COLS ***

5	4				
***	DEPTH	AREA	VOLUME	OUTFLOW	***
	(FT)	(ACRES)	(AC-FT)	(CFS)	***
	0.000	0.0010	0.0000	0.00	
	0.000	0.0100	0.0100	10.00	
	0.100	0.1000	0.1000	100.00	
	1.000	1.0000	1.0000	1000.00	
	10.000	10.0000	10.0000	10000.00	

END FTABLE238

FTABLE 338
 *** SASA DETENTION FACILITY RETROFIT SIZE ***
 ROWS COLS *** EFFECTIVE DEPTH=14 FT

14	4				
***	DEPTH	AREA	VOLUME	DISCH	***
	(FT)	(ACRES)	(AC-FT)	(CFS)	***
	0.00	0.000	0.00	0.00	
	1.31	2.802	3.620	13.70	
	2.30	2.881	6.472	18.14	
	3.40	2.983	9.761	22.05	
	4.22	3.043	12.296	24.57	
	5.32	3.151	15.809	27.59	
	6.14	3.233	18.514	29.65	
	7.13	3.326	21.878	33.26	
	8.05	3.426	25.103	38.80	
	10.10	3.608	32.636	56.04	
	11.20	3.699	36.880	76.55	
	12.29	4.053	41.227	99.16	
	13.12	4.154	44.633	116.70	
	14.40	4.311	50.050	144.31	

END FTABLE338

FTABLE 39
 *** SDS-1 DISCHARGE
 ROWS COLS ***

11	4				
***	DEPTH	AREA	VOLUME	OUTFLOW	OUTFLOW2
	(FT)	(ACRES)	(ACRE-FT)	(CFS)	(CFS)
	.000	.000	.000	.000	
	.250	.020	.030	2.200	
	.500	.027	.035	9.400	

.750	.031	.042	21.000
1.000	.035	.049	36.000
1.250	.039	0.056	53.600
1.500	.039	0.064	72.000
1.750	.041	0.074	89.500
2.000	.041	0.084	104.700
2.250	.041	0.094	114.200
2.500	.038	0.100	114.300

END FTABLE 39

FTABLE 40

*** TYEE POND

*** BASED ON TYEE POND AS-BUILTS AND AUTOMATED GATE OPERATION MANUAL

*** K RITLAND 2/4/98

ROWS COLS ***

20	4				
***	DEPTH	AREA	VOLUME	OUTFLOW	OUTFLOW2
	(FT)	(ACRES)	(ACRE-FT)	(CFS)	(CFS)
	0.00	0.00	0.00	0.00	0.00
	0.90	0.01	0.31	10.00	
	1.65	0.02	0.02	20.00	
	3.11	0.07	0.07	30.00	
	4.56	0.22	0.29	40.00	
	6.02	0.63	0.89	50.00	
	7.48	0.88	2.02	60.00	
	8.62	1.06	3.18	70.00	
	9.79	1.18	4.29	80.00	
	10.88	1.34	5.83	90.00	
	11.95	1.48	7.20	100.00	
	13.12	1.69	9.17	110.00	
	15.13	2.04	12.90	120.00	
	16.10	2.20	14.92	124.10	
	16.30	2.24	15.40	129.65	
	16.57	2.28	15.88	150.36	
	16.64	2.32	16.36	155.00	
	16.80	2.36	16.84	208.74	
	17.03	2.40	17.32	293.59	
	17.26	2.43	17.79	428.11	

END FTABLE 40

FTABLE 42

*** SDS-3 DETENTION VAULT EFFECTIVE DEPTH = 20.0 FT

ROWS COLS ***

17	4				
***	DEPTH	AREA	VOLUME	OUTFLOW	***
	(FT)	(ACRES)	(ACRE-FT)	(CFS)	***
	0.00	4.19	.00	0.00	
	0.51	4.19	2.254	0.95	
	1.37	4.19	6.054	1.55	
	3.33	4.19	14.716	2.42	
	6.07	4.19	26.824	3.28	
	8.43	4.19	37.254	3.86	
	10.00	4.19	44.192	4.20	
	12.74	4.19	56.301	4.74	
	14.50	4.19	64.078	5.06	
	15.46	4.19	68.321	8.74	
	16.63	4.19	73.491	10.66	
	18.39	4.19	81.269	16.63	
	20.00	4.19	88.384	20.79	
	20.20	4.19	89.268	23.84	
	20.70	4.19	91.477	39.37	
	21.00	4.19	92.803	52.07	
	21.90	4.19	96.780	71.43	

END FTABLE 42

FTABLE 43

*** NORTHWEST PONDS

*** BASED ON KING COUNTY BASIN PLANNING MODEL

ROWS COLS ***

17	5				
***	DEPTH	AREA	VOLUME	OUTFLOW	OUTFLOW2
	(FT)	(ACRES)	(ACRE-FT)	(CFS)	(CFS)
	0.000	12.000	0.000	0.000	0.00
	0.100	12.000	18.800	0.000	0.00
	1.000	12.000	24.000	0.200	0.00
	2.000	12.000	30.000	0.500	0.00

3.000	12.000	37.000	1.000	0.00
3.500	13.000	41.000	5.000	0.00
4.000	13.000	45.700	15.000	0.00
4.500	13.000	51.000	35.000	0.00
5.000	14.000	56.500	150.000	0.00
5.500	14.000	62.800	200.000	0.00
6.000	14.000	69.000	300.000	0.00
6.500	14.000	83.500	350.000	0.00
7.000	15.000	99.900	400.000	0.00
8.000	17.000	119.00	500.000	0.00
9.000	20.000	141.50	550.000	0.00
10.000	23.000	180.00	600.000	0.00
11.000	27.000	200.00	650.000	0.00

END FTABLE 43

FTABLE 46
 *** EXECUTEL POND
 ROWS COLS ***

20	4				
***	DEPTH	AREA	VOLUME	OUTFLOW	OUTFLOW2
	(FT)	(ACRES)	(ACRE-FT)	(CFS)	(CFS)
	.000	.000	.000	.000	
	1.000	.080	.080	24.420	
	2.000	.230	.310	34.540	
	3.000	.393	.703	42.300	
	3.500	.494	.950	45.690	
	4.000	.508	1.204	48.850	
	4.500	.532	1.470	51.810	
	5.000	.540	1.740	54.610	
	5.500	.540	2.010	57.280	
	6.000	.580	2.300	59.820	
	6.500	.600	2.600	62.270	
	7.000	.600	2.900	64.620	
	7.500	.600	3.200	66.900	
	8.000	.620	3.510	69.100	
	8.500	.640	3.830	71.200	
	9.000	.740	4.200	82.220	
	10.000	.650	4.850	119.830	
	11.000	.720	5.570	169.000	
	12.000	.750	6.320	250.900	
	13.000	1.000	7.320	500.900	

END FTABLE 46

FTABLE 47
 *** EXECUTEL POND DISCHARGE PIPELINE (C)
 ROWS COLS ***

11	4				
***	DEPTH	AREA	VOLUME	OUTFLOW	OUTFLOW2
	(FT)	(ACRES)	(ACRE-FT)	(CFS)	(CFS)
	.000	.000	.000	.000	
	.350	.069	.020	4.600	
	.700	.096	.056	19.200	
	1.050	.112	.099	42.800	
	1.400	.124	.150	73.400	
	1.750	.125	.203	109.000	
	2.100	.121	.240	146.600	
	2.450	.110	.264	182.400	
	2.800	.096	.284	213.200	
	3.150	.090	.290	232.400	
	3.500	.088	.293	232.600	

END FTABLE 47

FTABLE 177
 *** NORTH BRANCH RAVINE
 ROWS COLS ***

14	4				
***	DEPTH	AREA	VOLUME	OUTFLOW	OUTFLOW2
	(FT)	(ACRES)	(ACRE-FT)	(CFS)	(CFS)
	.000	.000	.000	.0	
	.500	.572	.191	7.3	
	1.000	.799	.438	23.2	
	2.000	.968	1.001	75.7	
	3.000	1.155	1.727	155.1	
	4.000	1.317	2.542	262.7	
	5.000	1.478	3.475	400.3	
	6.000	1.643	4.545	570.2	

7.000	1.791	5.688	774.4
8.000	1.932	6.822	1015.1
9.000	1.945	7.025	1294.5
10.000	1.958	7.244	1614.5
11.000	1.970	7.481	1977.0
12.000	1.983	7.734	2384.7

END FTABLE177

FTABLE 193
 *** UPPER RAVINE
 ROWS COLS ***

14	4				
***	DEPTH	AREA	VOLUME	OUTFLOW	OUTFLOW2
	(FT)	(ACRES)	(ACRE-FT)	(CFS)	(CFS)
	0.00	0.00	0.00	0.0	
	0.35	0.72	0.75	7.8	
	0.70	0.72	1.51	23.5	
	1.05	0.72	2.28	44.3	
	1.40	0.72	3.03	68.2	
	1.75	0.72	3.81	95.8	
	2.10	0.72	4.56	125.2	
	2.45	0.75	5.36	169.0	
	2.80	0.89	6.30	171.5	
	3.15	1.00	7.35	247.6	
	3.50	1.08	8.49	332.7	
	3.85	1.21	9.75	396.5	
	4.20	1.32	11.13	521.2	
	4.55	1.41	12.60	655.5	

END FTABLE193

FTABLE 198
 ROWS COLS ***

*** LOWER RAVINE
 *** ROUGH ESTIMATE BASED ON FIELD VISIT OF 12/20/95
 *** FLOW WAS 6 TO 7 CFS WITH DEPTH OF 3"
 *** NEAR OUTLET.
 *** DRIVE WHICH REPRESENTS A RESTRICTION ACCORDING TO OBSERVATION

8	4				
***	DEPTH	AREA	VOLUME	OUTFLOW	OUTFLOW2
	(FT)	(ACRES)	(ACRE-FT)	(CFS)	(CFS)
	0.00	0.00	0.00	0.0	
	1.00	0.50	0.80	10.0	
	2.00	0.55	1.30	25.0	
	3.00	0.60	1.80	50.0	
	5.00	0.70	2.50	100.0	
***	SUBMERGENCE OF CULVERT				
	10.00	2.50	12.00	245.0	
***	OVERBANK STORAGE				
***	FLOWS BASED ON 243', .03 D-W FACTOR, PLUS LOSS OF 1. VELOCITY HEAD				
	15.00	10.00	40.00	325.0	
	20.00	11.00	90.00	390.0	

END FTABLE198

FTABLE 38
 *** UPPER EAST BRANCH
 ROWS COLS ***

9	4				
***	DEPTH	AREA	VOLUME	OUTFLOW	
	(FT)	(ACRES)	(ACRE-FT)	(CFS)	***
	.000	.000	.000	.000	
	.500	.176	.100	9.200	
	1.000	.194	0.150	30.400	
	2.000	.232	0.200	105.800	
	3.000	.271	0.250	228.900	
	4.000	.310	0.350	405.800	
	5.000	.349	0.450	642.700	
	6.000	.387	0.600	945.700	
	7.000	.426	0.800	1320.700	

END FTABLE 38

FTABLE 360
 *** NORTH SATELLITE PUMP STATION (SDE-4) (INSTALLED IN 1995)
 ROWS COLS ***

5	5				
***	DEPTH	AREA	VOLUME	(IWS)	(SDS)
	(FT)	(ACRES)	(ACRE-FT)	(CFS)	(CFS)

AR 020395

.0	1.0	.00	0.00	0.00
1.00	1.0	.01	4.79	0.00
2.00	1.0	.02	4.79	0.00
3.00	1.0	.03	4.79	25.00
4.00	1.0	.04	4.79	50.00

END FTABLE360

FTABLE 366
 *** SOUTH SNOWMELT (OLYMPIC TANK FARM) PUMP STATION (INSTALLED IN LATE 1997/1998) ***
 ROWS COLS
 5 5
 DEPTH AREA VOLUME (IWS) (SDS)
 (FT) (ACRES) (ACRE-FT) (CFS) (CFS)
 .0 1.00 .00 0.00 0.00
 1.00 1.00 .01 1.67 0.00
 2.00 1.00 .02 1.67 0.00
 3.00 1.00 .03 1.67 25.00
 4.00 1.00 .04 1.67 50.00
 END FTABLE366

END FTABLES

COPY
 TIMESERIES
 Copy-opn ***
 # - # NPT NMN ***
 1 54 1
 END TIMESERIES
 END COPY

EXT SOURCES
 <-Volume-> <Member> SsysSgap<--Mult-->Tran <-Target vols> <-Grp> <-Member-> ***
 <Name> # <Name> # tem strg<-factor->strg <Name> # # <Name> # # ***
 WM 2 PREC ENGLZERO PERLND 14 54 EXTNL PREC
 WM 2 PREC ENGLZERO IMPLND 14 EXTNL PREC
 WDM 2 PREC ENGLZERO RCHRES 34 EXTNL PREC
 WDM 2 PREC ENGLZERO RCHRES 40 EXTNL PREC
 WDM 2 PREC ENGLZERO RCHRES 43 EXTNL PREC
 WDM 1 EVAP ENGLZERO 0.8 PERLND 14 440 EXTNL PETINP
 WDM 1 EVAP ENGLZERO 0.8 IMPLND 14 140 EXTNL PETINP
 WDM 1 EVAP ENGLZERO 0.8 RCHRES 34 EXTNL POTEV
 WDM 1 EVAP ENGLZERO 0.8 RCHRES 43 EXTNL POTEV
 WDM 1 EVAP ENGLZERO 0.8 RCHRES 40 EXTNL POTEV
 END EXT SOURCES

EXT TARGETS
 <-Volume-> <-Grp> <-Member-><--Mult-->Tran <-Volume-> <Member> Tsys Tgap Amd ***
 <Name> # <Name> # <-factor->strg <Name> # <Name> tem strg strg***

 *** SDS

 *** SDS-4 (TOTAL)
 RCHRES 36 HYDR RO WDM 221 FLOW ENGL REPL

 *** SDS-1 (TOTAL)
 RCHRES 39 HYDR RO WDM 222 FLOW ENGL REPL

 *** SDS-3
 RCHRES 42 HYDR RO WDM 257 FLOW ENGL REPL
 RCHRES 42 HYDR STAGE WDM 757 STAG ENGL REPL
 RCHRES 42 HYDR VOL WDM 857 VOL ENGL REPL

 *** SDS-4
 RCHRES 10 HYDR RO WDM 258 FLOW ENGL REPL
 RCHRES 10 HYDR STAGE WDM 758 STAG ENGL REPL
 RCHRES 10 HYDR VOL WDM 858 VOL ENGL REPL

 ** SDS-3A TAXIWAY VAULT
 RCHRES 20 HYDR RO WDM 224 FLOW ENGL REPL
 RCHRES 20 HYDR STAGE WDM 724 STAG ENGL REPL
 RCHRES 20 HYDR VOL WDM 824 VOL ENGL REPL

```

*****
* SDS-7 3RD RUNWAY VAULT
RCHRES 3 HYDR RO WDM 226 FLOW ENGL REPL
RCHRES 3 HYDR STAGE WDM 726 STAG ENGL REPL
RCHRES 3 HYDR VOL WDM 826 VOL ENGL REPL
*****
*** SASA DETENTION FACILITY
RCHRES 338 HYDR RO WDM 338 FLOW ENGL REPL
RCHRES 338 HYDR STAGE WDM 745 STAG ENGL REPL
RCHRES 338 HYDR VOL WDM 845 VOL ENGL REPL
*****
*** EVALUATION POINT 1 FOR SDS DISCHARGE TO WEST BRANCH
COPY 41 OUTPUT MEAN 1 12.1 WDM 260 FLOW ENGL REPL
*****
*** EVALUATION POINT 2 FOR SDS DISCHARGE TO WEST BRANCH
COPY 4 OUTPUT MEAN 1 12.1 WDM 261 FLOW ENGL REPL
*****
*** WEST BRANCH
*****
*** NORTHWEST PONDS
RCHRES 43 HYDR RO WDM 231 FLOW ENGL REPL
*****
*** LOWER WEST BRANCH
RCHRES 12 HYDR RO WDM 235 FLOW ENGL REPL
*****
*** EAST BRANCH
*****
*** BOW LAKE OUTFLOW
RCHRES 35 HYDR RO WDM 236 FLOW ENGL REPL
RCHRES 37 HYDR RO WDM 37 FLOW ENGL REPL
*** D/S SASA
RCHRES 38 HYDR RO WDM 245 FLOW ENGL REPL
*****
*** TYEE INFLOW (GAUGE 11C)
RCHRES 5 HYDR RO WDM 238 FLOW ENGL REPL
*****
*** TYEE OUTFLOW
RCHRES 40 HYDR RO WDM 239 FLOW ENGL REPL
*****
*** MAIN STEM
*****
*** BELOW CONFLUENCE AT TYEE GOLF COURSE WEIR (GAUGE 11F)
COPY 5 OUTPUT MEAN 1 12.1 WDM 240 FLOW ENGL REPL
*****
*** BELOW CONFLUENCE AT SOUTH 200TH STREET
RCHRES 13 HYDR RO WDM 241 FLOW ENGL REPL
*****
*** LOWER DES MOINES CREEK NEAR MOUTH (GAUGE 11D)
RCHRES 198 HYDR RO WDM 242 FLOW ENGL REPL
*****
END EXT TARGETS
***
NETWORK
*** <MEMBER> SSSYSSGAP<--MULT-->TRAN <--TARGET VOLS> <--MEMBER-->
<NAME> # <NAME> TEM STRG<--FACTOR-->STRG <NAME> # # <--GRP> <NAME> # # ***
*****
*** AIRPORT SUBBASINS
*****
*** (DM23) SDE-4
*** GW contributions added
PERLND 26 PWATER SURO 3.344 RCHRES 36 EXTNL IVOL
PERLND 26 PWATER IFWO 3.344 RCHRES 36 EXTNL IVOL
PERLND 26 PWATER AGNO 0.137 RCHRES 36 EXTNL IVOL
IMPLND 14 IWATER SURO 10.507 RCHRES 36 EXTNL IVOL
*****
* (DM24) SDS-1
*** GW contributions added
PERLND 26 PWATER SURO 0.115 RCHRES 39 EXTNL IVOL
PERLND 26 PWATER IFWO 0.115 RCHRES 39 EXTNL IVOL

```

PERLND	26	PWATER	AGWO	0.115	RCHRES	39	EXTNL	IVOL
IMPLND	14	IWATER	SURO	1.360	RCHRES	39	EXTNL	IVOL

** (DM25) SDS-3A TAXIWAY VAULT								
PERLND	26	PWATER	SURO	2.886	RCHRES	20	EXTNL	IVOL
PERLND	26	PWATER	IFWO	2.886	RCHRES	20	EXTNL	IVOL
IMPLND	14	IWATER	SURO	2.928	RCHRES	20	EXTNL	IVOL

*** (DM25) SDS-7 3RD RUNWAY VAULT								
PERLND	26	PWATER	SURO	3.808	RCHRES	3	EXTNL	IVOL
PERLND	26	PWATER	IFWO	3.808	RCHRES	3	EXTNL	IVOL
PERLND	44	PWATER	SURO	0.327	RCHRES	3	EXTNL	IVOL
PERLND	44	PWATER	IFWO	0.327	RCHRES	3	EXTNL	IVOL
PERLND	45	PWATER	SURO	0.457	RCHRES	3	EXTNL	IVOL
PERLND	45	PWATER	IFWO	0.457	RCHRES	3	EXTNL	IVOL
IMPLND	14	IWATER	SURO	3.013	RCHRES	3	EXTNL	IVOL

*** (DM25) SDS-3								
**** GW contributions added								
PERLND	26	PWATER	SURO	12.026	RCHRES	42	EXTNL	IVOL
PERLND	26	PWATER	IFWO	12.026	RCHRES	42	EXTNL	IVOL
PERLND	26	PWATER	AGWO	0.246	RCHRES	42	EXTNL	IVOL
IMPLND	14	IWATER	SURO	16.598	RCHRES	42	EXTNL	IVOL

****SDS-6*NEW WATERSHED								
*** GW contributions added								
PERLND	26	PWATER	SURO	1.128	COPY	50	INPUT	MEAN 1
PERLND	26	PWATER	IFWO	1.128	COPY	50	INPUT	MEAN 1
PERLND	26	PWATER	AGWO	0.135	COPY	50	INPUT	MEAN 1
PERLND	44	PWATER	SURO	*****	COPY	50	INPUT	MEAN 1
PERLND	44	PWATER	IFWO	*****	COPY	50	INPUT	MEAN 1
PERLND	54	PWATER	SURO	*****	COPY	50	INPUT	MEAN 1
PERLND	54	PWATER	IFWO	*****	COPY	50	INPUT	MEAN 1
IMPLND	14	IWATER	SURO	0.265	COPY	50	INPUT	MEAN 1

****SDS-5*NEW WATERSHED								
****GW contributions added								
PERLND	26	PWATER	SURO	2.356	COPY	41	INPUT	MEAN 1
PERLND	26	PWATER	IFWO	2.356	COPY	41	INPUT	MEAN 1
PERLND	26	PWATER	AGWO	0.796	COPY	41	INPUT	MEAN 1
PERLND	44	PWATER	SURO	*****	COPY	41	INPUT	MEAN 1
PERLND	44	PWATER	IFWO	*****	COPY	41	INPUT	MEAN 1
PERLND	54	PWATER	SURO	*****	COPY	41	INPUT	MEAN 1
PERLND	54	PWATER	IFWO	*****	COPY	41	INPUT	MEAN 1
IMPLND	14	IWATER	SURO	0.348	COPY	41	INPUT	MEAN 1

****SDS-2*NEW WATERSHED								
**** GW contributions added								
PERLND	26	PWATER	SURO	0.249	COPY	4	INPUT	MEAN 1
PERLND	26	PWATER	IFWO	0.249	COPY	4	INPUT	MEAN 1
PERLND	26	PWATER	AGWO	0.249	COPY	4	INPUT	MEAN 1
PERLND	44	PWATER	SURO	0.384	COPY	4	INPUT	MEAN 1
PERLND	44	PWATER	IFWO	0.384	COPY	4	INPUT	MEAN 1
PERLND	44	PWATER	AGWO	0.384	COPY	4	INPUT	MEAN 1
PERLND	54	PWATER	SURO	0.043	COPY	4	INPUT	MEAN 1
PERLND	54	PWATER	IFWO	0.043	COPY	4	INPUT	MEAN 1
PERLND	54	PWATER	AGWO	0.043	COPY	4	INPUT	MEAN 1
IMPLND	14	IWATER	SURO	0.086	COPY	4	INPUT	MEAN 1

*** (DM27) SDS-4								
PERLND	26	PWATER	SURO	0.564	RCHRES	10	EXTNL	IVOL
PERLND	26	PWATER	IFWO	0.564	RCHRES	10	EXTNL	IVOL
PERLND	26	PWATER	AGWO	0.564	COPY	5	INPUT	MEAN 1
PERLND	44	PWATER	SURO	2.109	RCHRES	10	EXTNL	IVOL
PERLND	44	PWATER	IFWO	2.109	RCHRES	10	EXTNL	IVOL
PERLND	44	PWATER	AGWO	2.109	COPY	5	INPUT	MEAN 1
IMPLND	14	IWATER	SURO	2.707	RCHRES	10	EXTNL	IVOL

*** SASA STORM								
*** PERLND 26 added for surface water and GW								
PERLND	26	PWATER	SURO	0.001	COPY	15	INPUT	MEAN 1
PERLND	26	PWATER	IFWO	0.001	COPY	15	INPUT	MEAN 1
PERLND	26	PWATER	AGWO	0.001	COPY	15	INPUT	MEAN 1
IMPLND	14	IWATER	SURO	2.855	COPY	15	INPUT	MEAN 1

```

*** MC-9 GW added (from Miller Creek)
PERLND 26 PWATER AGWO          0.005      RCHRES 43      EXTNL  IVOL
*****
** IWS SYSTEM PUMP STATION OVERFLOWS
*****
*** I-3: NORTH SATELLITE PUMP STATION (NSPS) TO IWS
*** OVERFLOW TO SDE-4
*** INSTALLED IN 1995
PERLND 26 PWATER SURO          0.026      RCHRES 360     EXTNL  IVOL
PERLND 26 PWATER IFWO          0.026      RCHRES 360     EXTNL  IVOL
IMPLND 14 IWATER SURO          1.120      RCHRES 360     EXTNL  IVOL
*****
*** I-5: SOUTH SNOWMELT (OLYMPIC TANK FARM) PUMP STATION (SSMPS) TO IWS
*** OVERFLOW TO DES MOINES EAST BRANCH
*** INSTALLED IN LATE 1997/1998
IMPLND 14 IWATER SURO          0.001      RCHRES 366     EXTNL  IVOL
*****
*** SASA IWS
*** AGWO revised
PERLND 26 PWATER SURO          0.004      COPY      8      INPUT  MEAN  1
PERLND 26 PWATER IFWO          0.004      COPY      8      INPUT  MEAN  1
PERLND 26 PWATER AGWO          0.004      COPY      5      INPUT  MEAN  1
PERLND 44 PWATER SURO          0.004      COPY      8      INPUT  MEAN  1
PERLND 44 PWATER IFWO          0.004      COPY      8      INPUT  MEAN  1
PERLND 44 PWATER AGWO          0.004      COPY      5      INPUT  MEAN  1
PERLND 54 PWATER SURO          0.001      COPY      8      INPUT  MEAN  1
PERLND 54 PWATER IFWO          0.001      COPY      8      INPUT  MEAN  1
PERLND 54 PWATER AGWO          0.001      COPY      5      INPUT  MEAN  1
IMPLND 14 IWATER SURO          4.850      COPY      8      INPUT  MEAN  1
*****
*** Add IWS groundwater
***PERLND 26 PWATER AGWO          0.393      COPY      5      INPUT  MEAN  1
***PERLND 44 PWATER AGWO          0.512      COPY      5      INPUT  MEAN  1
*** EAST BRANCH OF CREEK
*****
*** DM1
PERLND 16 PWATER SURO          0.860      RCHRES 34      EXTNL  IVOL
PERLND 16 PWATER IFWO          0.860      RCHRES 34      EXTNL  IVOL
PERLND 16 PWATER AGWO          0.241      RCHRES 34      EXTNL  IVOL
PERLND 26 PWATER SURO          11.078     RCHRES 34      EXTNL  IVOL
PERLND 26 PWATER IFWO          11.078     RCHRES 34      EXTNL  IVOL
PERLND 26 PWATER AGWO          3.102      RCHRES 34      EXTNL  IVOL
PERLND 34 PWATER SURO          0.599      RCHRES 34      EXTNL  IVOL
PERLND 34 PWATER IFWO          0.599      RCHRES 34      EXTNL  IVOL
PERLND 34 PWATER AGWO          0.168      RCHRES 34      EXTNL  IVOL
PERLND 44 PWATER SURO          7.697      RCHRES 34      EXTNL  IVOL
PERLND 44 PWATER IFWO          7.697      RCHRES 34      EXTNL  IVOL
PERLND 44 PWATER AGWO          2.155      RCHRES 34      EXTNL  IVOL
PERLND 54 PWATER SURO          1.176      RCHRES 34      EXTNL  IVOL
PERLND 54 PWATER IFWO          1.176      RCHRES 34      EXTNL  IVOL
PERLND 54 PWATER AGWO          0.329      RCHRES 34      EXTNL  IVOL
IMPLND 14 IWATER SURO          14.274     RCHRES 34      EXTNL  IVOL
*****
*** DM2
PERLND 26 PWATER SURO          1.232      RCHRES 37      EXTNL  IVOL
PERLND 26 PWATER IFWO          1.232      RCHRES 37      EXTNL  IVOL
IMPLND 14 IWATER SURO          0.821      RCHRES 37      EXTNL  IVOL
*****
*** DM3
*** PERO replaced with SURO, IFWO and AGWO.
PERLND 26 PWATER SURO          3.554      RCHRES 5       EXTNL  IVOL
PERLND 26 PWATER IFWO          3.554      RCHRES 5       EXTNL  IVOL
PERLND 26 PWATER AGWO          3.537      RCHRES 5       EXTNL  IVOL
PERLND 54 PWATER SURO          0.006      RCHRES 5       EXTNL  IVOL
PERLND 54 PWATER IFWO          0.006      RCHRES 5       EXTNL  IVOL
PERLND 54 PWATER AGWO          0.006      RCHRES 5       EXTNL  IVOL
IMPLND 14 IWATER SURO          4.508      RCHRES 5       EXTNL  IVOL
*****
*** contribution from non-contiguous basin
PERLND 26 PWATER AGWO          0.016      RCHRES 5       EXTNL  IVOL
*** DM4
*** PERO replaced with SURO, IFWO and AGWO.
PERLND 16 PWATER SURO          0.286      RCHRES 5       EXTNL  IVOL
PERLND 16 PWATER IFWO          0.286      RCHRES 5       EXTNL  IVOL

```

PERLND	16	PWATER	AGWO	0.286	RCHRES	5	EXTNL	IVOL
PERLND	26	PWATER	SURO	0.591	RCHRES	5	EXTNL	IVOL
PERLND	26	PWATER	IFWO	0.591	RCHRES	5	EXTNL	IVOL
PERLND	26	PWATER	AGWO	0.590	RCHRES	5	EXTNL	IVOL
PERLND	54	PWATER	SURO	0.005	RCHRES	5	EXTNL	IVOL
PERLND	54	PWATER	IFWO	0.005	RCHRES	5	EXTNL	IVOL
PERLND	54	PWATER	AGWO	0.005	RCHRES	5	EXTNL	IVOL
IMPLND	14	IWATER	SURO	3.357	RCHRES	5	EXTNL	IVOL

 *** contribution from non-contiguous basin
 PERLND 26 PWATER AGWO 0.001 RCHRES 5 EXTNL IVOL

*** DM5
 *** PERO replaced with SURO, IFWO and AGWO.
 PERLND 16 PWATER SURO 0.173 RCHRES 5 EXTNL IVOL
 PERLND 16 PWATER IFWO 0.173 RCHRES 5 EXTNL IVOL
 PERLND 16 PWATER AGWO 0.173 RCHRES 5 EXTNL IVOL
 PERLND 26 PWATER SURO 0.485 RCHRES 5 EXTNL IVOL
 PERLND 26 PWATER IFWO 0.485 RCHRES 5 EXTNL IVOL
 PERLND 26 PWATER AGWO 0.485 RCHRES 5 EXTNL IVOL
 PERLND 34 PWATER SURO 0.074 RCHRES 5 EXTNL IVOL
 PERLND 34 PWATER IFWO 0.074 RCHRES 5 EXTNL IVOL
 PERLND 34 PWATER AGWO 0.074 RCHRES 5 EXTNL IVOL
 PERLND 44 PWATER SURO 0.077 RCHRES 5 EXTNL IVOL
 PERLND 44 PWATER IFWO 0.077 RCHRES 5 EXTNL IVOL
 PERLND 44 PWATER AGWO 0.077 RCHRES 5 EXTNL IVOL
 PERLND 54 PWATER SURO 0.112 RCHRES 5 EXTNL IVOL
 PERLND 54 PWATER IFWO 0.112 RCHRES 5 EXTNL IVOL
 PERLND 54 PWATER AGWO 0.112 RCHRES 5 EXTNL IVOL
 IMPLND 14 IWATER SURO 0.799 RCHRES 5 EXTNL IVOL

*** DM6
 *** PERO replaced with SURO, IFWO and AGWO.
 PERLND 16 PWATER PERO ***** RCHRES 40 EXTNL IVOL
 PERLND 26 PWATER SURO 0.534 RCHRES 40 EXTNL IVOL
 PERLND 26 PWATER IFWO 0.534 RCHRES 40 EXTNL IVOL
 PERLND 26 PWATER AGWO 0.534 RCHRES 40 EXTNL IVOL
 PERLND 34 PWATER SURO 0.002 RCHRES 40 EXTNL IVOL
 PERLND 34 PWATER IFWO 0.002 RCHRES 40 EXTNL IVOL
 PERLND 34 PWATER AGWO 0.002 RCHRES 40 EXTNL IVOL
 PERLND 44 PWATER SURO 0.709 RCHRES 40 EXTNL IVOL
 PERLND 44 PWATER IFWO 0.709 RCHRES 40 EXTNL IVOL
 PERLND 44 PWATER AGWO 0.709 RCHRES 40 EXTNL IVOL
 PERLND 54 PWATER SURO 0.312 RCHRES 40 EXTNL IVOL
 PERLND 54 PWATER IFWO 0.312 RCHRES 40 EXTNL IVOL
 PERLND 54 PWATER AGWO 0.312 RCHRES 40 EXTNL IVOL
 IMPLND 14 IWATER SURO 0.007 RCHRES 40 EXTNL IVOL

*** WEST BRANCH OF CREEK

*** DM7
 *** AGWO revised
 PERLND 16 PWATER SURO 2.190 RCHRES 7 EXTNL IVOL
 PERLND 16 PWATER IFWO 2.190 RCHRES 7 EXTNL IVOL
 PERLND 16 PWATER AGWO 1.701 RCHRES 7 EXTNL IVOL
 PERLND 26 PWATER SURO 2.944 RCHRES 7 EXTNL IVOL
 PERLND 26 PWATER IFWO 2.944 RCHRES 7 EXTNL IVOL
 PERLND 26 PWATER AGWO 0.759 RCHRES 7 EXTNL IVOL
 PERLND 34 PWATER SURO 1.970 RCHRES 7 EXTNL IVOL
 PERLND 34 PWATER IFWO 1.970 RCHRES 7 EXTNL IVOL
 PERLND 34 PWATER AGWO 0.681 RCHRES 7 EXTNL IVOL
 PERLND 44 PWATER SURO 4.143 RCHRES 7 EXTNL IVOL
 PERLND 44 PWATER IFWO 4.143 RCHRES 7 EXTNL IVOL
 PERLND 44 PWATER AGWO 0.313 RCHRES 7 EXTNL IVOL
 PERLND 54 PWATER SURO 0.552 RCHRES 7 EXTNL IVOL
 PERLND 54 PWATER IFWO 0.552 RCHRES 7 EXTNL IVOL
 PERLND 54 PWATER AGWO 0.370 RCHRES 7 EXTNL IVOL
 IMPLND 14 IWATER SURO 2.401 RCHRES 7 EXTNL IVOL

*** DM8
 *** AGWO revised
 PERLND 16 PWATER SURO 0.203 RCHRES 7 EXTNL IVOL
 PERLND 16 PWATER IFWO 0.203 RCHRES 7 EXTNL IVOL
 PERLND 16 PWATER AGWO 0.000 RCHRES 7 EXTNL IVOL
 PERLND 26 PWATER SURO 0.609 RCHRES 7 EXTNL IVOL
 PERLND 26 PWATER IFWO 0.609 RCHRES 7 EXTNL IVOL

PERLND	26	PWATER	AGWO	0.098	RCHRES	7	EXTNL	IVOL
PERLND	34	PWATER	SURO	0.715	RCHRES	7	EXTNL	IVOL
PERLND	34	PWATER	IFWO	0.715	RCHRES	7	EXTNL	IVOL
PERLND	34	PWATER	AGWO	0.226	RCHRES	7	EXTNL	IVOL
PERLND	44	PWATER	SURO	1.133	RCHRES	7	EXTNL	IVOL
PERLND	44	PWATER	IFWO	1.133	RCHRES	7	EXTNL	IVOL
PERLND	44	PWATER	AGWO	0.154	RCHRES	7	EXTNL	IVOL
PERLND	54	PWATER	SURO	0.161	RCHRES	7	EXTNL	IVOL
PERLND	54	PWATER	IFWO	0.161	RCHRES	7	EXTNL	IVOL
PERLND	54	PWATER	AGWO	0.116	RCHRES	7	EXTNL	IVOL
IMPLND	14	IWATER	SURO	2.422	RCHRES	7	EXTNL	IVOL

*** DM9

*** AGWO revised

PERLND	16	PWATER	SURO	0.002	RCHRES	9	EXTNL	IVOL
PERLND	16	PWATER	IFWO	0.002	RCHRES	9	EXTNL	IVOL
PERLND	16	PWATER	AGWO	0.002	RCHRES	9	EXTNL	IVOL
PERLND	26	PWATER	SURO	1.201	RCHRES	9	EXTNL	IVOL
PERLND	26	PWATER	IFWO	1.201	RCHRES	9	EXTNL	IVOL
PERLND	26	PWATER	AGWO	0.425	RCHRES	9	EXTNL	IVOL
PERLND	34	PWATER	SURO	0.017	RCHRES	9	EXTNL	IVOL
PERLND	34	PWATER	IFWO	0.017	RCHRES	9	EXTNL	IVOL
PERLND	34	PWATER	AGWO	0.017	RCHRES	9	EXTNL	IVOL
PERLND	44	PWATER	SURO	3.040	RCHRES	9	EXTNL	IVOL
PERLND	44	PWATER	IFWO	3.040	RCHRES	9	EXTNL	IVOL
PERLND	44	PWATER	AGWO	1.512	RCHRES	9	EXTNL	IVOL
PERLND	54	PWATER	SURO	0.010	RCHRES	9	EXTNL	IVOL
PERLND	54	PWATER	IFWO	0.010	RCHRES	9	EXTNL	IVOL
PERLND	54	PWATER	AGWO	0.010	RCHRES	9	EXTNL	IVOL
IMPLND	14	IWATER	SURO	0.634	RCHRES	9	EXTNL	IVOL

*** DM10

*** PERO replaced with SURO, IFWO, and AGWO

PERLND	16	PWATER	SURO	0.945	RCHRES	43	EXTNL	IVOL
PERLND	16	PWATER	IFWO	0.945	RCHRES	43	EXTNL	IVOL
PERLND	16	PWATER	AGWO	0.945	RCHRES	43	EXTNL	IVOL
PERLND	26	PWATER	SURO	0.738	RCHRES	43	EXTNL	IVOL
PERLND	26	PWATER	IFWO	0.738	RCHRES	43	EXTNL	IVOL
PERLND	26	PWATER	AGWO	0.738	RCHRES	43	EXTNL	IVOL
PERLND	34	PWATER	SURO	1.935	RCHRES	43	EXTNL	IVOL
PERLND	34	PWATER	IFWO	1.935	RCHRES	43	EXTNL	IVOL
PERLND	34	PWATER	AGWO	1.935	RCHRES	43	EXTNL	IVOL
PERLND	44	PWATER	SURO	0.510	RCHRES	43	EXTNL	IVOL
PERLND	44	PWATER	IFWO	0.510	RCHRES	43	EXTNL	IVOL
PERLND	44	PWATER	AGWO	0.510	RCHRES	43	EXTNL	IVOL
PERLND	54	PWATER	SURO	0.712	RCHRES	43	EXTNL	IVOL
PERLND	54	PWATER	IFWO	0.712	RCHRES	43	EXTNL	IVOL
PERLND	54	PWATER	AGWO	0.712	RCHRES	43	EXTNL	IVOL
IMPLND	14	IWATER	SURO	0.185	RCHRES	43	EXTNL	IVOL

*** DM11

*** PERO replaced with SURO, IFWO, and AGWO

PERLND	16	PWATER	SURO	0.321	RCHRES	43	EXTNL	IVOL
PERLND	16	PWATER	IFWO	0.321	RCHRES	43	EXTNL	IVOL
PERLND	16	PWATER	AGWO	0.321	RCHRES	43	EXTNL	IVOL
PERLND	26	PWATER	SURO	0.408	RCHRES	43	EXTNL	IVOL
PERLND	26	PWATER	IFWO	0.408	RCHRES	43	EXTNL	IVOL
PERLND	16	PWATER	AGWO	0.408	RCHRES	43	EXTNL	IVOL
PERLND	34	PWATER	SURO	1.024	RCHRES	43	EXTNL	IVOL
PERLND	34	PWATER	IFWO	1.024	RCHRES	43	EXTNL	IVOL
PERLND	34	PWATER	AGWO	1.024	RCHRES	43	EXTNL	IVOL
PERLND	44	PWATER	SURO	0.467	RCHRES	43	EXTNL	IVOL
PERLND	44	PWATER	IFWO	0.467	RCHRES	43	EXTNL	IVOL
PERLND	44	PWATER	AGWO	0.467	RCHRES	43	EXTNL	IVOL
PERLND	54	PWATER	SURO	1.036	RCHRES	43	EXTNL	IVOL
PERLND	54	PWATER	IFWO	1.036	RCHRES	43	EXTNL	IVOL
PERLND	54	PWATER	AGWO	1.036	RCHRES	43	EXTNL	IVOL
IMPLND	14	IWATER	SURO	2.726	RCHRES	43	EXTNL	IVOL

*** DM12

*** PERO replaced with SURO, IFWO, and AGWO

PERLND	16	PWATER	SURO	0.510	RCHRES	12	EXTNL	IVOL
PERLND	16	PWATER	IFWO	0.510	RCHRES	12	EXTNL	IVOL
PERLND	16	PWATER	AGWO	0.510	RCHRES	12	EXTNL	IVOL
PERLND	26	PWATER	SURO	0.001	RCHRES	12	EXTNL	IVOL
PERLND	26	PWATER	IFWO	0.001	RCHRES	12	EXTNL	IVOL

PERLND	26	PWATER	AGWO	0.001	RCHRES	12	EXTNL	IVOL
PERLND	34	PWATER	SURO	0.375	RCHRES	12	EXTNL	IVOL
PERLND	34	PWATER	IFWO	0.375	RCHRES	12	EXTNL	IVOL
PERLND	34	PWATER	AGWO	0.375	RCHRES	12	EXTNL	IVOL
PERLND	44	PWATER	SURO	1.728	RCHRES	12	EXTNL	IVOL
PERLND	44	PWATER	IFWO	1.728	RCHRES	12	EXTNL	IVOL
PERLND	44	PWATER	AGWO	1.728	RCHRES	12	EXTNL	IVOL
PERLND	54	PWATER	SURO	0.554	RCHRES	12	EXTNL	IVOL
PERLND	54	PWATER	IFWO	0.554	RCHRES	12	EXTNL	IVOL
PERLND	54	PWATER	AGWO	0.554	RCHRES	12	EXTNL	IVOL

*** DM13

*** PERO replaced with SURO, IFWO, and AGWO

PERLND	16	PWATER	SURO	0.961	RCHRES	13	EXTNL	IVOL
PERLND	16	PWATER	IFWO	0.961	RCHRES	13	EXTNL	IVOL
PERLND	16	PWATER	AGWO	0.961	RCHRES	13	EXTNL	IVOL
PERLND	26	PWATER	SURO	1.562	RCHRES	13	EXTNL	IVOL
PERLND	26	PWATER	IFWO	1.562	RCHRES	13	EXTNL	IVOL
PERLND	26	PWATER	AGWO	1.562	RCHRES	13	EXTNL	IVOL
PERLND	34	PWATER	SURO	1.203	RCHRES	13	EXTNL	IVOL
PERLND	34	PWATER	IFWO	1.203	RCHRES	13	EXTNL	IVOL
PERLND	34	PWATER	AGWO	1.203	RCHRES	13	EXTNL	IVOL
PERLND	44	PWATER	SURO	1.778	RCHRES	13	EXTNL	IVOL
PERLND	44	PWATER	IFWO	1.778	RCHRES	13	EXTNL	IVOL
PERLND	44	PWATER	AGWO	1.778	RCHRES	13	EXTNL	IVOL
PERLND	54	PWATER	SURO	0.089	RCHRES	13	EXTNL	IVOL
PERLND	54	PWATER	IFWO	0.089	RCHRES	13	EXTNL	IVOL
PERLND	54	PWATER	AGWO	0.089	RCHRES	13	EXTNL	IVOL
IMPLND	14	IWATER	SURO	1.259	RCHRES	13	EXTNL	IVOL

*** LOWER BASIN

*** DM14

PERLND	16	PWATER	PERO	0.481	RCHRES	14	EXTNL	IVOL
PERLND	26	PWATER	PERO	0.295	RCHRES	14	EXTNL	IVOL
PERLND	34	PWATER	PERO	1.940	RCHRES	14	EXTNL	IVOL
PERLND	44	PWATER	PERO	1.195	RCHRES	14	EXTNL	IVOL
IMPLND	14	IWATER	SURO	0.340	RCHRES	14	EXTNL	IVOL

*** EXECUTEL TRIBUTARY

*** DM16 INFLOW TO EXECUTEL POND

PERLND	16	PWATER	SURO	0.647	RCHRES	46	EXTNL	IVOL
PERLND	16	PWATER	IFWO	0.647	RCHRES	46	EXTNL	IVOL
PERLND	16	PWATER	AGWO	0.446	RCHRES	46	EXTNL	IVOL
PERLND	26	PWATER	SURO	5.573	RCHRES	46	EXTNL	IVOL
PERLND	26	PWATER	IFWO	5.573	RCHRES	46	EXTNL	IVOL
PERLND	26	PWATER	AGWO	3.845	RCHRES	46	EXTNL	IVOL
PERLND	34	PWATER	SURO	0.639	RCHRES	46	EXTNL	IVOL
PERLND	34	PWATER	IFWO	0.639	RCHRES	46	EXTNL	IVOL
PERLND	34	PWATER	AGWO	0.441	RCHRES	46	EXTNL	IVOL
PERLND	44	PWATER	SURO	8.023	RCHRES	46	EXTNL	IVOL
PERLND	44	PWATER	IFWO	8.023	RCHRES	46	EXTNL	IVOL
PERLND	44	PWATER	AGWO	5.536	RCHRES	46	EXTNL	IVOL
PERLND	54	PWATER	SURO	0.183	RCHRES	46	EXTNL	IVOL
PERLND	54	PWATER	IFWO	0.183	RCHRES	46	EXTNL	IVOL
PERLND	54	PWATER	AGWO	0.126	RCHRES	46	EXTNL	IVOL
IMPLND	14	IWATER	SURO	4.249	RCHRES	46	EXTNL	IVOL

*** DM17

PERLND	16	PWATER	PERO	2.078	RCHRES	17	EXTNL	IVOL
PERLND	26	PWATER	PERO	2.261	RCHRES	17	EXTNL	IVOL
PERLND	34	PWATER	PERO	3.003	RCHRES	17	EXTNL	IVOL
PERLND	44	PWATER	PERO	3.280	RCHRES	17	EXTNL	IVOL
IMPLND	14	IWATER	SURO	2.655	RCHRES	17	EXTNL	IVOL

*** MAINSTEM RAVINE

*** DM18

PERLND	16	PWATER	PERO	0.789	RCHRES	18	EXTNL	IVOL
PERLND	26	PWATER	PERO	0.277	RCHRES	18	EXTNL	IVOL
PERLND	34	PWATER	PERO	3.151	RCHRES	18	EXTNL	IVOL
PERLND	44	PWATER	PERO	1.106	RCHRES	18	EXTNL	IVOL

PERLND	54	PWATER	PERO	0.300	RCHRES	18	EXTNL	IVOL
IMPLND	14	IWATER	SURO	0.296	RCHRES	18	EXTNL	IVOL

*** NORTH BRANCH RAVINE

*** DM19

PERLND	16	PWATER	PERO	0.182	RCHRES	177	EXTNL	IVOL
PERLND	26	PWATER	PERO	6.019	RCHRES	177	EXTNL	IVOL
PERLND	34	PWATER	PERO	3.157	RCHRES	177	EXTNL	IVOL
PERLND	44	PWATER	PERO	5.552	RCHRES	177	EXTNL	IVOL
IMPLND	14	IWATER	SURO	2.617	RCHRES	177	EXTNL	IVOL

*** DM20

PERLND	16	PWATER	PERO	4.007	RCHRES	193	EXTNL	IVOL
PERLND	26	PWATER	PERO	6.624	RCHRES	193	EXTNL	IVOL
PERLND	34	PWATER	PERO	2.784	RCHRES	193	EXTNL	IVOL
PERLND	44	PWATER	PERO	4.602	RCHRES	193	EXTNL	IVOL
PERLND	54	PWATER	PERO	0.116	RCHRES	193	EXTNL	IVOL
IMPLND	14	IWATER	SURO	3.714	RCHRES	193	EXTNL	IVOL

*** LOWER MAINSTEM

*** DM21

PERLND	16	PWATER	PERO	2.143	RCHRES	198	EXTNL	IVOL
PERLND	26	PWATER	PERO	6.306	RCHRES	198	EXTNL	IVOL
PERLND	34	PWATER	PERO	1.429	RCHRES	198	EXTNL	IVOL
PERLND	44	PWATER	PERO	4.205	RCHRES	198	EXTNL	IVOL
IMPLND	14	IWATER	SURO	3.091	RCHRES	198	EXTNL	IVOL

*** DM22

PERLND	16	PWATER	PERO	0.381	RCHRES	198	EXTNL	IVOL
PERLND	26	PWATER	PERO	4.654	RCHRES	198	EXTNL	IVOL
PERLND	34	PWATER	PERO	0.218	RCHRES	198	EXTNL	IVOL
PERLND	44	PWATER	PERO	2.620	RCHRES	198	EXTNL	IVOL
PERLND	54	PWATER	PERO	0.016	RCHRES	198	EXTNL	IVOL
IMPLND	14	IWATER	SURO	1.972	RCHRES	198	EXTNL	IVOL

*** NONCONTIGUOUS GROUNDWATER BASINS

*** G1

PERLND	16	PWATER	AGWO	2.833	RCHRES	5	EXTNL	IVOL
PERLND	26	PWATER	AGWO	9.917	RCHRES	5	EXTNL	IVOL

*** G2

PERLND	16	PWATER	AGWO	0.417	RCHRES	193	EXTNL	IVOL
PERLND	26	PWATER	AGWO	1.333	RCHRES	193	EXTNL	IVOL

*** G3

PERLND	16	PWATER	AGWO	5.083	RCHRES	193	EXTNL	IVOL
PERLND	26	PWATER	AGWO	17.667	RCHRES	193	EXTNL	IVOL
PERLND	34	PWATER	AGWO	1.167	RCHRES	193	EXTNL	IVOL
PERLND	44	PWATER	AGWO	4.250	RCHRES	193	EXTNL	IVOL

*** CHANNEL NETWORK LINKAGES ***

*** PUMP STATION OVERFLOW TO SDS

RCHRES	360	HYDR	OVOL	2	RCHRES	36	EXTNL	IVOL
RCHRES	366	HYDR	OVOL	2	RCHRES	5	EXTNL	IVOL

*** EAST BRANCH OF CREEK

RCHRES	34	HYDR	OVOL	1	RCHRES	35	EXTNL	IVOL
RCHRES	35	HYDR	ROVOL	1	RCHRES	37	EXTNL	IVOL
RCHRES	36	HYDR	ROVOL	1	RCHRES	338	EXTNL	IVOL
COPY	15	OUTPDT	MEAN	1	RCHRES	338	EXTNL	IVOL
RCHRES	39	HYDR	ROVOL	1	RCHRES	338	EXTNL	IVOL

RCHRES 37 HYDR ROVOL 1	RCHRES 338	EXTNL	IVOL
RCHRES 338 HYDR ROVOL 1	RCHRES 38	EXTNL	IVOL
RCHRES 38 HYDR ROVOL 1	RCHRES 5	EXTNL	IVOL
RCHRES 5 HYDR ROVOL 1	RCHRES 40	EXTNL	IVOL
RCHRES 40 HYDR ROVOL 1	COPY 5	INPUT	MEAN 1

*** WEST BRANCH OF CREEK

RCHRES 20 HYDR ROVOL 1	COPY 9	INPUT	MEAN 1
RCHRES 42 HYDR ROVOL 1	COPY 9	INPUT	MEAN 1
COPY 9 OUTPUT MEAN 1	RCHRES 4	EXTNL	IVOL
RCHRES 4 HYDR ROVOL 1	COPY 41	INPUT	MEAN 1
COPY 50 OUTPUT MEAN 1	RCHRES 3	EXTNL	IVOL
RCHRES 3 HYDR ROVOL 1	COPY 4	INPUT	MEAN 1
RCHRES 7 HYDR ROVOL 1	COPY 4	INPUT	MEAN 1
RCHRES 9 HYDR ROVOL 1	COPY 4	INPUT	MEAN 1
COPY 41 OUTPUT MEAN 1	RCHRES 43	EXTNL	IVOL
COPY 4 OUTPUT MEAN 1	RCHRES 43	EXTNL	IVOL
RCHRES 43 HYDR ROVOL 1	RCHRES 12	EXTNL	IVOL
RCHRES 10 HYDR ROVOL 1	COPY 5	INPUT	MEAN 1
RCHRES 12 HYDR ROVOL 1	COPY 5	INPUT	MEAN 1

*** MAINSTEM BELOW CONFLUENCE OF E. AND W. BRANCH

*** MAINSTEM ABOVE EXECUTEL TRIBUTARY			
COPY 5 OUTPUT MEAN 1	RCHRES 13	EXTNL	IVOL
RCHRES 13 HYDR ROVOL 1	RCHRES 14	EXTNL	IVOL
RCHRES 14 HYDR ROVOL 1	COPY 48	INPUT	MEAN 1

*** EXECUTEL TRIBUTARY

RCHRES 46 HYDR ROVOL 1	RCHRES 47	EXTNL	IVOL
RCHRES 47 HYDR ROVOL 1	RCHRES 17	EXTNL	IVOL
RCHRES 17 HYDR ROVOL 1	COPY 48	INPUT	MEAN 1

*** MAINSTEM FROM HEAD OF RAVINE TO NORTH BRANCH CONFLUENCE

COPY 48 OUTPUT MEAN 1	RCHRES 18	EXTNL	IVOL
RCHRES 18 HYDR ROVOL 1	RCHRES 193	EXTNL	IVOL
RCHRES 193 HYDR ROVOL 1	COPY 1	INPUT	MEAN 1

*** NORTH BRANCH RAVINE TO MAINSTEM

RCHRES 177 HYDR ROVOL 1	COPY 1	INPUT	MEAN 1
-------------------------	--------	-------	--------

*** MAINSTEM FROM NORTH BRANCH CONFLUENCE TO PARK BELOW MVD CULVERT

COPY 1 OUTPUT MEAN 1	RCHRES 198	EXTNL	IVOL
----------------------	------------	-------	------

END NETWORK

END RUN

AR 020404

HSPF Non-Contiguous Groundwater Areas

For the purposes of the low flow HSPF models, the project condition 2006 surface water basins were divided into contiguous and non-contiguous groundwater basins based on the future groundwater divide. A non-contiguous groundwater area occurs where the groundwater flows to a different stream or water body than the surface runoff from that same area. The attached figure shows the contiguous and non-contiguous groundwater areas for Des Moines, Walker, and Miller Creeks.

For Des Moines Creek, the groundwater routing of contiguous and non-contiguous areas for each subbasin was unchanged in the 1994 and 2006 conditions. Pervious land segments are per the land use tables contained in Appendix A.

For Walker Creek, during the calibration of the Walker Creek model, it was determined that 630 acres of non-contiguous groundwater area drain to the creek. The low flow models use 2006 surface water subbasin boundaries, which aren't necessarily coincident with the 1994 surface water subbasins used in the calibration model. Therefore, it was necessary to independently track those areas which transition from contiguous to non-contiguous, and vice versa, from the 1994 subbasin boundaries to the 2006 subbasin boundaries. These transitional areas are hatched and labeled on the attached figure.

The groundwater routing from the transitional areas was tracked separately from the 630 acres of non-contiguous groundwater area. The pervious area of Walker Creek that transitions from non-contiguous to contiguous from the 1994 to the 2006 subbasin boundaries (groundwater basin SDW2B) was subtracted from the 630 acres to prevent double counting. These steps were taken so that the added impervious area from 1994 to 2006 conditions for each of the groundwater areas could be calculated.

For Miller Creek, there are three subbasins (SDW2, SDS3A, and SDE4) with non-contiguous groundwater areas that are routed to Miller Creek in the 1994 and 2006 conditions. SDS3A and SDE4 are located in the Des Moines Creek surface basin and SDW2 is located in the Walker Creek basin.

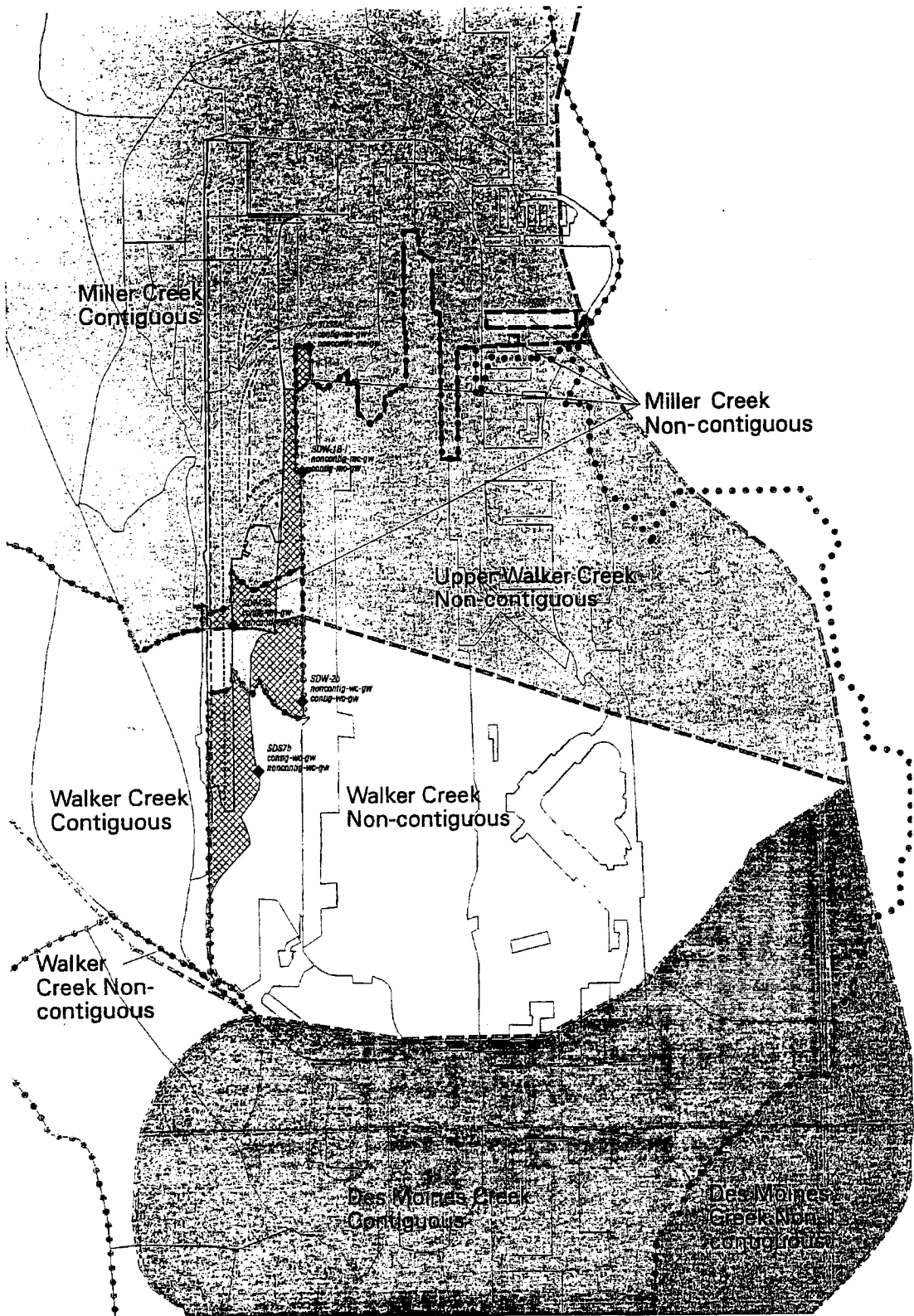

Prepared by Parametric, Inc. File: s2002/ghw/ghw2001/ghw2001_1205-ft-qrchange-04.gxd Date: December 07, 2001

 Scale in Feet	Portion of groundwater basin which changes from 1994 to 2006	Upper Walker Creek non-contiguous groundwater basin	Surface water subbasin boundary
	Miller Creek contiguous groundwater basin	Walker Creek non-contiguous groundwater basin	Future watershed boundary
Walker Creek contiguous groundwater basin	Des Moines Creek non-contiguous groundwater basin	Boundary of the Pacific Groundwater Group	Change between Existing (1994) and Future (2006) Groundwater Basins
Des Moines Creek contiguous groundwater basin	Miller Creek Non-contiguous groundwater basin	Boundary of filter strip (modified by Pacific Groundwater Group)	
Miller Creek Non-contiguous groundwater basin		Boundary of runway (modified by Pacific Groundwater Group)	
		(2006 surface water basin) (1994 groundwater basin) (2006 groundwater basin)	

AR 020406

